

CLICK ANYWHERE on THIS PAGE to RETURN TO MANUALS & PARTS GUIDES - HVAC at InspectApedia.com

Evaporator Coil Installation Instructions



A-Coil
Page 4



Multi-position A-Coil
Page 4 - 7



Slab Coil
Page 5



Horizontal A-Coil
Top Connection
Page 5



Horizontal A-Coil
Side Connection
Page 5



PRODUCT IMPROVEMENT IS A CONTINUOUS PROCESS AT ADVANCED DISTRIBUTOR PRODUCTS. THEREFORE, PRODUCT SPECIFICATIONS ARE SUBJECT TO CHANGE WITHOUT NOTICE AND WITHOUT OBLIGATION ON OUR PART. PLEASE CONTACT YOUR ADP REPRESENTATIVE OR DISTRIBUTOR TO VERIFY DETAILS. © BY ADVANCED DISTRIBUTOR PRODUCTS. ALL RIGHTS RESERVED.

* Only applies to C-Series upflow/downflow cased A-Coil

**Large Tonnage A & H Coils (greater than 5 Tons) are not AHRI Certified

GENERAL

ADP evaporator coils are designed for use with condensing units or heat pump units. These instructions are intended as a general guide and do not supersede local codes in any way. Consult with local authorities having jurisdiction before installation. **Read this installation manual and all "Warning" statements prior to installing the evaporator coil.**

Check coil for shipping damage and verify the contents of the box containing the evaporator coil. If you should find damage, immediately contact the last carrier. Verify the efficiency requirements are appropriate with the matched condensing or heat pump units such as capacity, SEER, EER, and/or HSPF. Check outdoor unit manufacturer for proper line sizing. It is recommended that the coil be washed with a coil cleaner to remove any residual oil that may have been left from the manufacturing process. **Coils are shipped with a 10 psi dry air holding charge. Puncture rubber plug on suction line to release charge before removing plugs.** The absence of pressure does not verify a leak. Check the coil for leaks before installing or returning it to your wholesaler.

Position the coil on the outlet of the furnace using sheet metal screws. Drain pans are made of a polymer that can withstand temperatures up to 450 deg. F. **Maintain a 3" clearance on oil or drum type heat exchangers and 1½" on sectionalized heat exchangers.** Coil should be level, or pitched slightly toward the drain connection. **Airflow face velocity above 350 ft/min. is not recommended for downflow or counterflow applications due to potential water blow-off.** Refer to Engineering & Specification Guide for limitations.

REFRIGERANT METERING

Coils are suited for R-22 and R-410A refrigerants and can be used with or without a TXV. Replacement TXV part numbers are listed below; see kit instructions for change out or installation. ADP recommends placing a wet rag around the suction line at the cabinet during brazing to prevent overheating and damaging the sensing bulb. For optimum performance, the bulb should be reattached outside of the cabinet to the main suction line no more than one foot from the suction line connection and positioned on the suction line at 9 or 3 O'clock and insulated. When changing a system from AC to heat pump or heat pump to AC check the current TXV specifications to determine if a TXV replacement is required. **If the evaporator coil contains a Non-Bleed TXV and is used with a condensing unit containing a reciprocating compressor, a hard start mechanism will be required on the outdoor unit.**

Large Tonnage A-Coils of 7.5 Ton (R-410A) cooling capacity include an adjustable TXV that can be used to fine tune superheat. Turn adjustment clockwise to increase superheat 4°F per turn and counterclockwise to decrease superheat 4°F per turn. To return to factory setting, turn adjustment stem counterclockwise until the spring is completely unloaded (reaches stop or starts to "ratchet"). Then, turn it back 6 "Total Turns".

R-22 TXV Part #s		R-410A TXV Part #s	
18-36 MBTUH Bleed A/C	65540600	18-36 MBTUH Non-Bleed A/C	65026401
42-60 MBTUH Bleed A/C	65540700	42-60 MBTUH Non-Bleed A/C	65026400
18-36 MBTUH Non-Bleed A/C	99167501	18-36 MBTUH Non-Bleed A/C-HP	65616601
42-60 MBTUH Non-Bleed A/C	99167502	42-60 MBTUH Non-Bleed A/C-HP	65616602
18-36 MBTUH Non-Bleed A/C-HP	65616201		
42-60 MBTUH Non-Bleed A/C-HP	65616202		

! IMPORTANT !

When changing the expansion valve, the TXV MUST match the refrigerant type and capacity of the condensing unit. Failure to do so will result in poor performance and possible compressor damage. All coils must be matched properly as listed in the AHRI directory.

Cased coils with piston flator assemblies are shipped with a cap and nut over the threaded fitting. Remove the cap and nut slowly, allowing charge to escape, and secure the liquid line stub (attached to cabinet) to the flator assembly with nut. Discard cap.

For optimum performance, the piston should be sized to match the recommendation from the outdoor unit manufacturer. If the outdoor unit manufacturer does not recommend a piston size refer to the piston-sizing chart on page 3.

When changing ADP flator pistons refer to the Figure 1 and use the following procedure:

1. Loosen hex nut located on liquid line and separate from distributor assembly.
2. Remove the existing piston from inside the distributor assembly.
3. Insert the desired ADP piston into the distributor assembly.
4. Inspect Teflon O-Ring and replace if damaged. Ensure Teflon O-Ring is in place.
5. Re-install flator nut to body and torque to 10 ft-lbs.

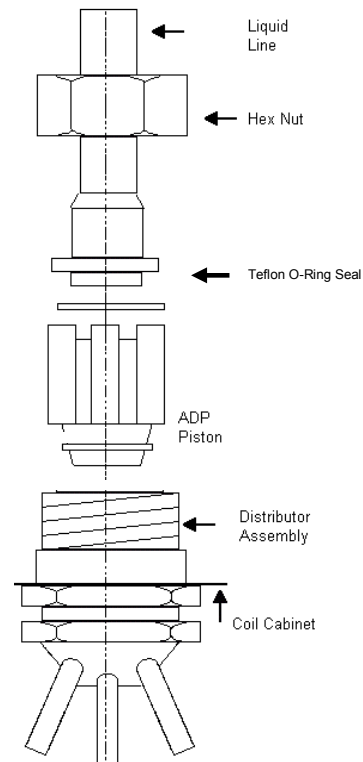

Figure 1

Florator Piston Size					
		R-22		R-410A	
Ton		Piston Size	Part #	Piston Size	Part #
1		41	100000035	41	100000035
1.5		53	100000036	49	100000049
2		59	100000037	53	100000036
2.5		67	100000039	59	100000037
3		73	100000041	67	100000039
3.5		80	100000044	73	100000041
4		84	100000045	76	100000042
5		93	100000047	93	100000047

CONDENSATE DRAIN

Coils are equipped with multiple drain connections. Determine the drain connections to be used and note the difference between the primary (green) and secondary (red) openings. Drain plugs are provided for all openings, remove and discard the appropriate plugs with ½" drive ratchet and verify that remaining plugs are tight. (2.5 ft-lbs) Attach drain line to pan with ¾" male pipe thread PVC fittings. Hand tight is adequate - **Do not over tighten & do not reduce drain line size!**

Route drain(s) line so they will not be exposed to freezing temperatures and do not interfere with accessibility to the coil, air handling system or filter. The drain should be pitched downward 1" per 10' with a 2" trap as close to the coil as possible. If line makes a second trap, or has an extended run before termination, a vent tee should be installed after the trap closest to the pan. See Figure 2.

If the coil is located in or above a living space where damage may result from condensate overflow, a separate ¾" drain must be provided from the secondary drain connection. Run this drain to a place in compliance with local installation codes where it will be noticed when unit is operational. Condensate flowing from the secondary drain indicates a plugged primary drain. Prime the trap with water. Test line for leaks. Test water flow with unit in operation. **An auxiliary drain pan should also be installed under the unit as specified by most local building codes.**

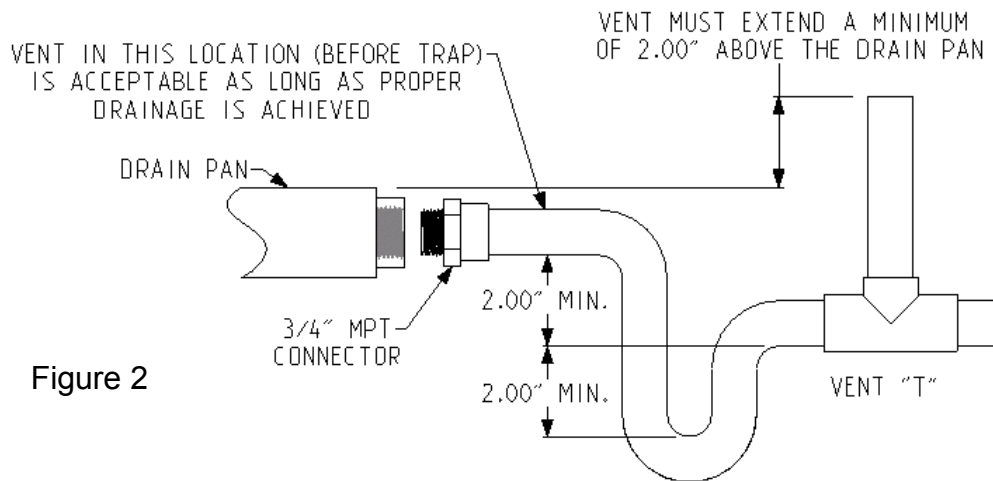

Figure 2

! WARNING !

Product contains fiberglass wool. Disturbing the insulation in this product during installation, maintenance or repair will expose you to fiberglass wool. This material may cause respiratory, skin, and eye irritant. Breathing this may cause lung cancer. (Fiberglass wool is known to the State of California to cause cancer.)

IMPORTANT

The Clean Air Act of 1990 bans the intentional venting of refrigerant (CFC's and HFC's). Approved methods of reclaiming must be followed. Fines and/or incarceration may be levied for non-compliance.

A-COIL

A-Coils are designed for upflow/downflow applications. Vertical drain pans have drain connections on the right and left front side of the evaporator coil. **Airflow face velocity above 350 ft/min. is not recommended for down-flow applications due to potential water blow-off.** Refer to Engineering & Specification Guide for limitations. In down-flow applications aluminum foil tape must be applied to seal the top edge of the insulation to the cabinet. This tape will prevent the possibility of the insulation delaminating and blocking airflow.

MULTI-POSITION A-COIL

Multi-position coils come factory installed with a vertical and horizontal drain pan, which can be configured for up-flow, down-flow, horizontal blow-through or horizontal pull-through installations. In the center opening of vertical drain pan, a metal Inlet Air Restrictor is factory installed and is required for horizontal applications. It may be removed for vertical applications. **Airflow face velocity above 350 ft/min. is not recommended for downflow or counterflow applications due to potential water blow-off.** Refer to Engineering & Specification Guide for limitations. Install splashguard (included) onto the coil outlet when used in a horizontal configurations. Splashguard installation is not required for vertical configurations. Bottom flange of guard should rest on pan and sides screwed to the duct flanges. **See page 5, Figures 6-8 for detailed splashguard instructions.**

In down-flow and pull-through configurations aluminum foil tape must be applied to seal the top edge of the insulation to the cabinet. This tape will prevent the possibility of the insulation delaminating and blocking airflow. In horizontal pull-through configurations a minimum 12" transition is required in front of the coil as shown in the figure below. This is required to ensure proper airflow distribution and to reduce pressure drop. Coils that are 20" or less in height and are installed in a cabinet with a height of 25-1/2" or greater do not require a transition, all other coil models require this transition. Coil should be level, or pitched slightly toward the drain connection. It is recommended to add silicone caulk between drain pans to prevent water carryover. **Note: Multi-position Coils are also field convertible from left-to-right or right-to-left; see page 6 for detailed instructions on field conversion for horizontal airflow.**

Pre system startup checklist for Multi-Position coils – Refer to Figure 3

- Is splash guard installed? (Figure 3 Configurations A and B)
- Airflow adjusted to rated CFM?
- Is 12" transition installed as shown below? (non-standard horizontal applications)
- Factory installed Inlet Air Restrictor present in the center opening of the drain pan (horizontal applications)?
- Factory installed internal water diverter in place? Refer to item 4 in Figure 9 under Multi-Position A-Coil Field Conversion on page 6.
- Unit slightly tilted toward drain connection used?
- Drain line connected and trapped per these instructions?

Figure 3

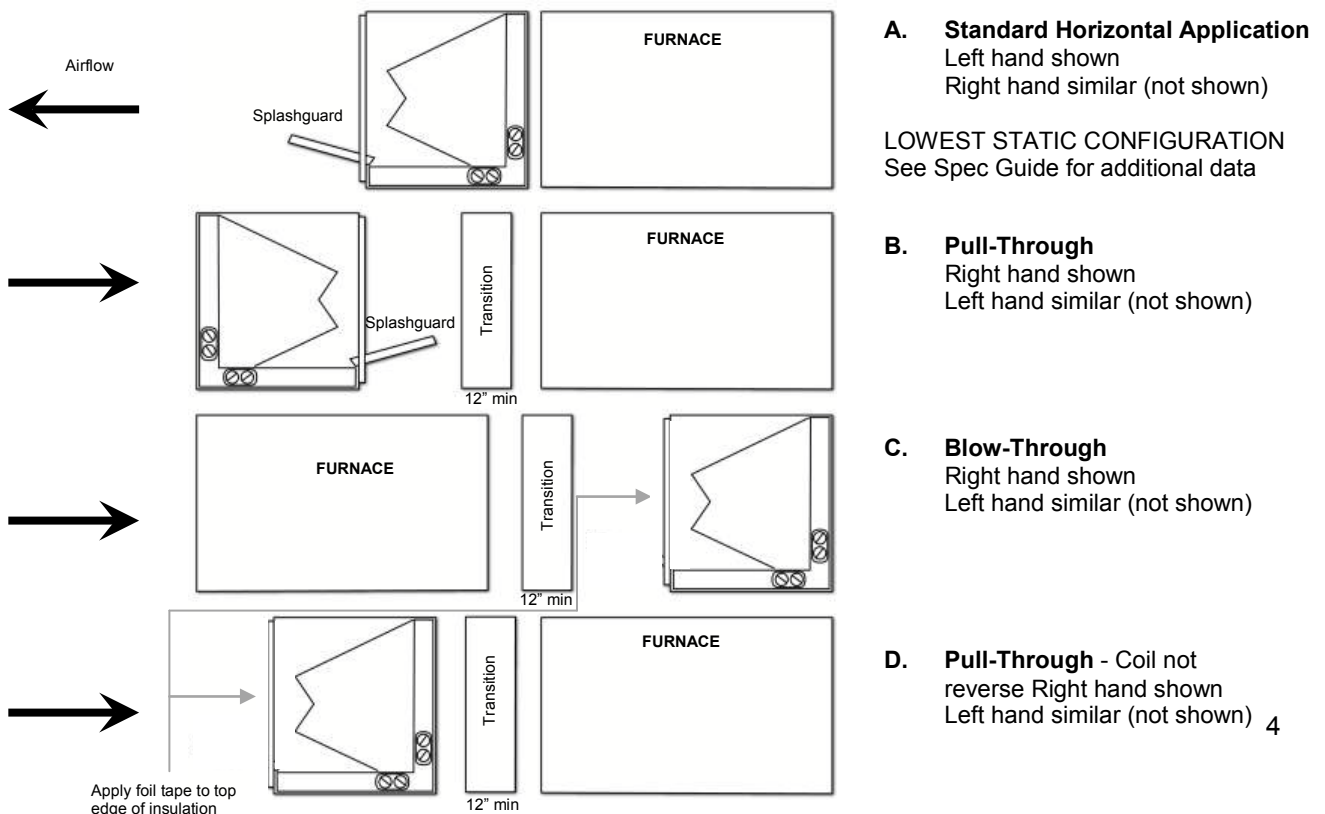

HORIZONTAL A COIL & SLAB COIL

Horizontal A and HH Slab Coils are designed for horizontal applications only. Proper performance for Horizontal A-Coils requires that the air flow out through the tip of coil as shown in Figure 4. HH Coils are bidirectional and requires a transitional duct to complete installation. All Horizontal A-Coils include furnace plate adaptors to facilitate proper fit with furnaces of different widths. For Horizontal A-Coils with suction lines on side of cabinet and in areas of high humidity the suction line section in the air stream in the cabinet should be insulated with Armaflex® insulation. See Figure 5.



Figure 4 Horizontal A-Coil w/ Top Connections

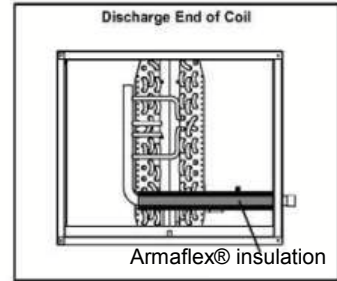

Figure 5 Horizontal A-Coil w/ Side Connections

MULTI-POSITION A-COIL SPLASHGUARD

Figure 6

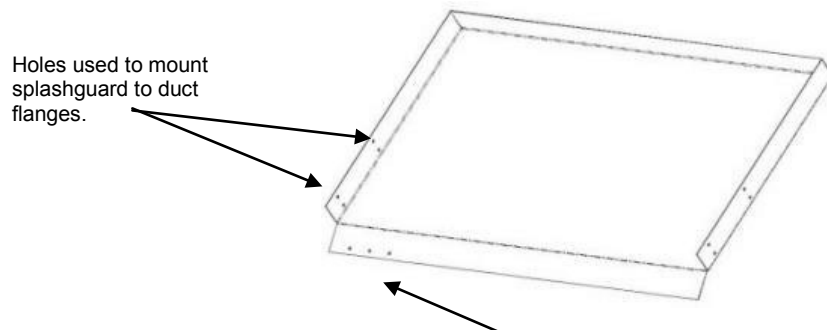

Figure 7

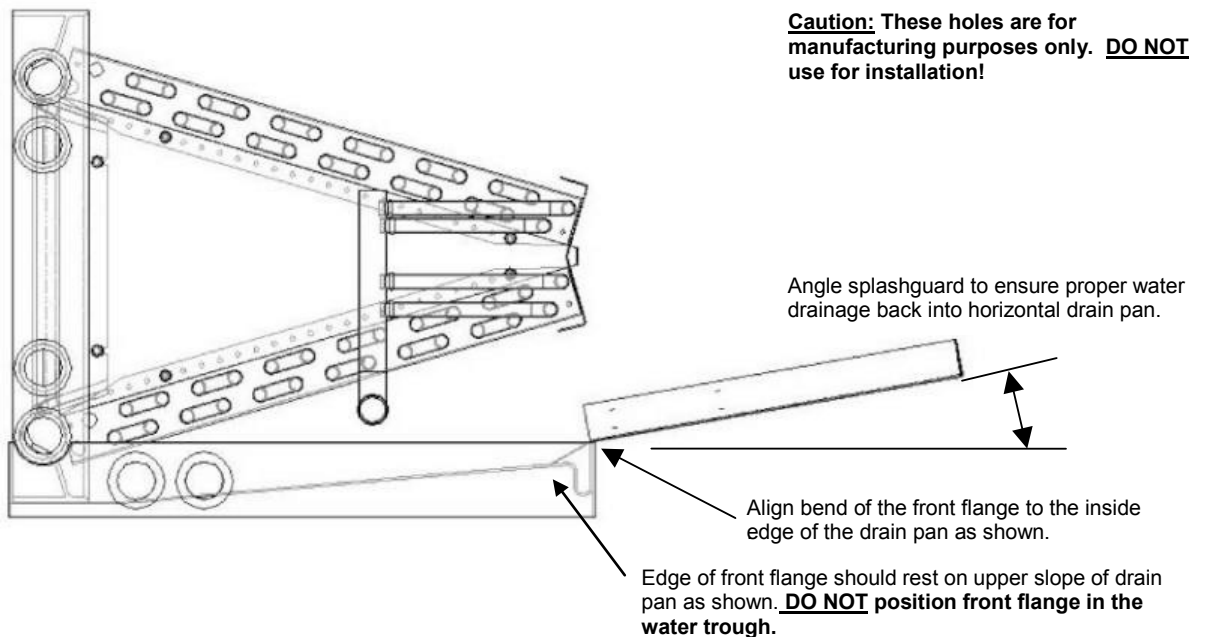
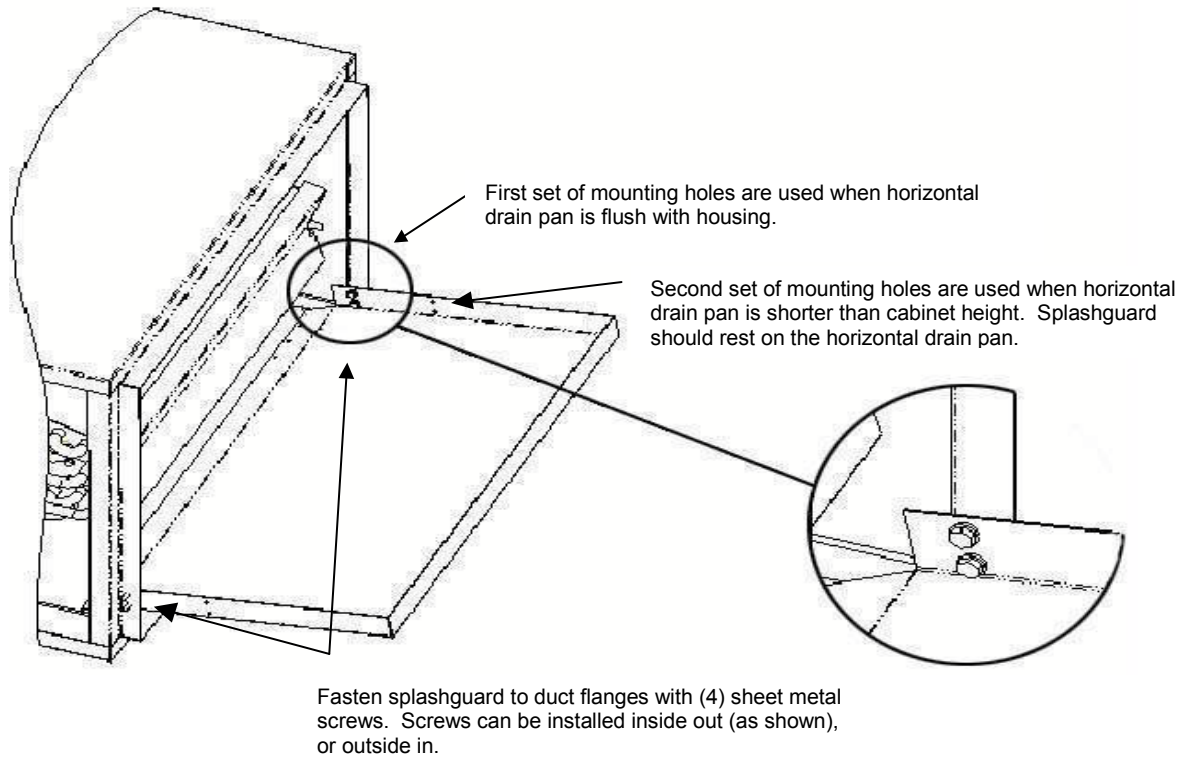

Figure 8



MULTI-POSITION A-COIL FIELD CONVERSION

Field Conversion Instructions from Left-to-Right or Right-to-Left Airflow

Note: Horizontal right-to-left conversion shown; however, horizontal left-to-right conversion is typical. Models beginning with *E41 and *A91 are not field convertible. (* Reflects different cabinet color options.)

SEE FIGURE 9. FOR STEPS 1 THRU 5

1. Remove front panels from unit, and pull the coil assembly from the housing.
2. Remove the horizontal drain pan, and re-install it to the opposite side of the coil. Note: horizontal drain pan must have drain plugs tightly closed in the rear of the unit.
3. Remove the top plate.
4. Remove the water diverter, and re-install it to the opposite slab.
5. Replace the top plate, and apply sealant to seal any air gaps.

Figure 9

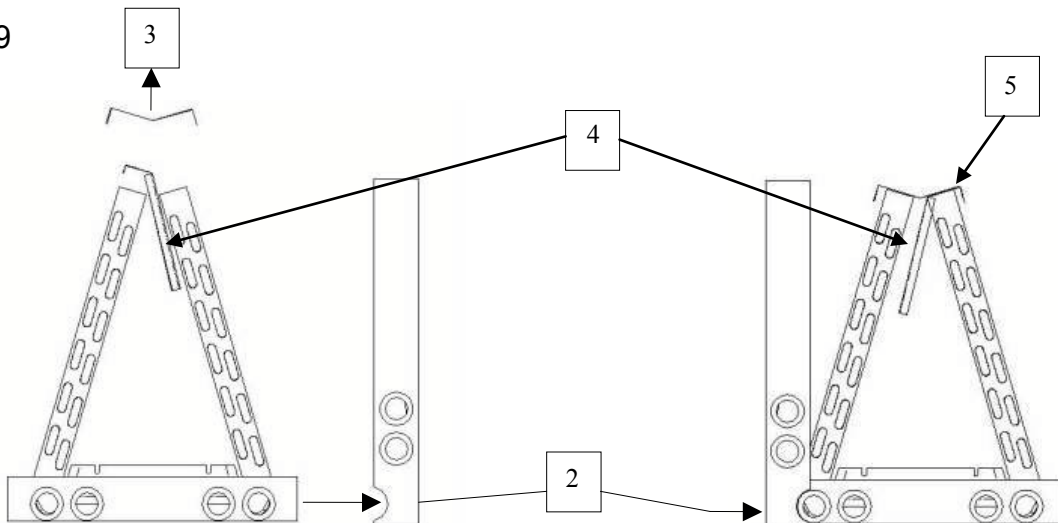

SEE FIGURE 10 FOR STEPS 6 THRU 10

6. Before re-inserting the coil assembly cut the front flange on the housing and fold it back to allow access to the horizontal drain connections.
7. Slide the coil assembly back into the housing. Note: If unit is equipped with a sheet metal housing adapter, it will have to be moved to the opposite side of the housing.
8. Re-install the piping panel to the housing.
9. Cut a hole in the access panel to allow access to the horizontal drain connections, and re-install the access panel to the housing.
10. Seal old condensate drain connection cutout holes in the front panel to prevent air leakage.

Figure 10

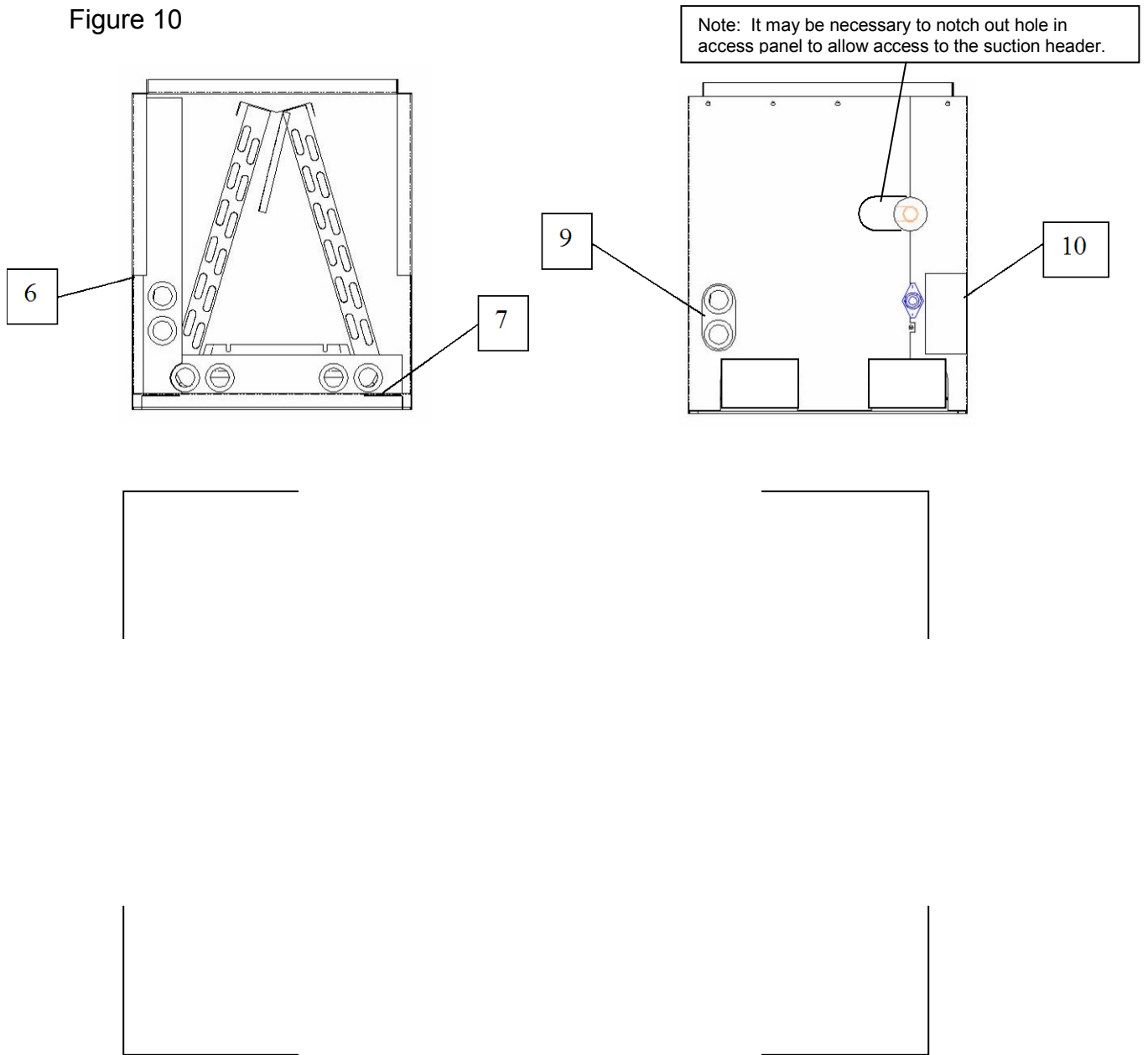

REFRIGERANT CHARGING INSTRUCTIONS

Outdoor temperature should be 60°F or higher. Set the system to cooling mode and charge per the applicable method listed below. For Heat Pump units initially charged in cooling mode, final adjustment to charge in heating mode is acceptable if necessary. When charging Heat Pumps in the heating mode please refer to the outdoor unit's charging instructions.

FIXED ORIFICE

1. Run system for at least 10 minutes to allow pressure to stabilize.
2. Add or recover refrigerant until the superheat matches the table below.

Outdoor Air Temp. (°F)	Superheat (°F)		
	Min	Nom	Max
60	28	31	34
65	25	28	31
70	22	25	28
75	20	22	25
80	16	20	22
85	13	16	20
90	10	13	16
95	6	10	12
100	6	8	10
105	4	6	8
110	4	5	6
115	4	5	6

EXPANSION VALVE

1. Run system for at least 10 minutes to allow pressure to stabilize.
2. Add or recover refrigerant until the subcooling matches the table below.
3. If equipped, adjust the valve until the superheat matches the table below.

Subcooling (°F)			Superheat (°F)		
Min	Nom	Max	Min	Nom	Max
10	12	14	6	10	12



Advanced Distributor Products®

Solutions for Your needs

2175 West Park Place Boulevard
 Stone Mountain, GA. 30087
www.adpnow.com
adp.feedback@adpnow.com