

March 12, 1974

C. M. HANLON ET AL

3,796,586

DEEP EMBOSSED, SHINGLE LAP SIDING

Filed Sept. 8, 1971

2 Sheets-Sheet 1

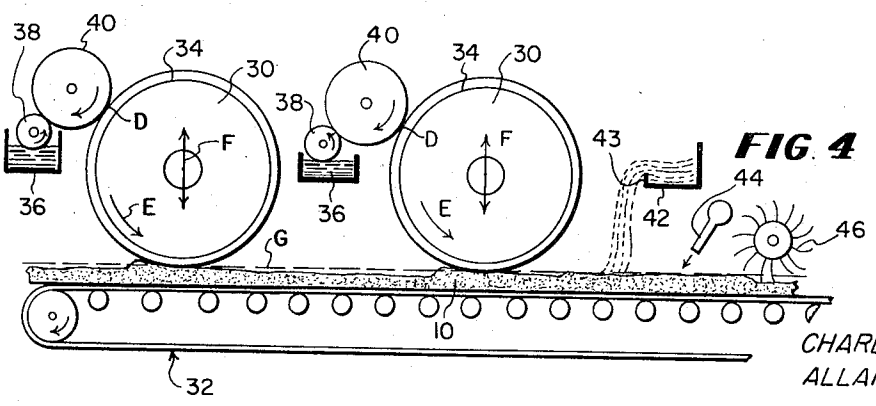
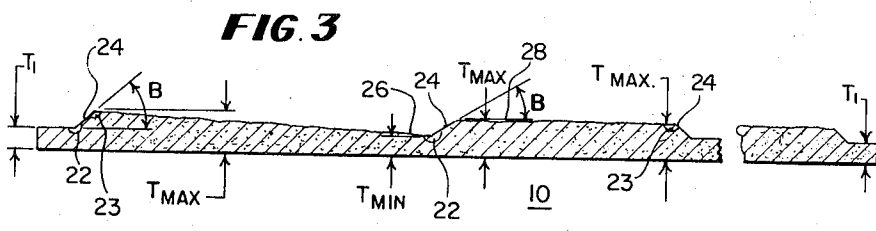
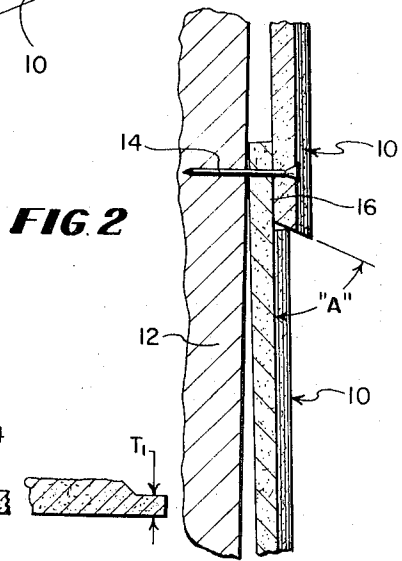
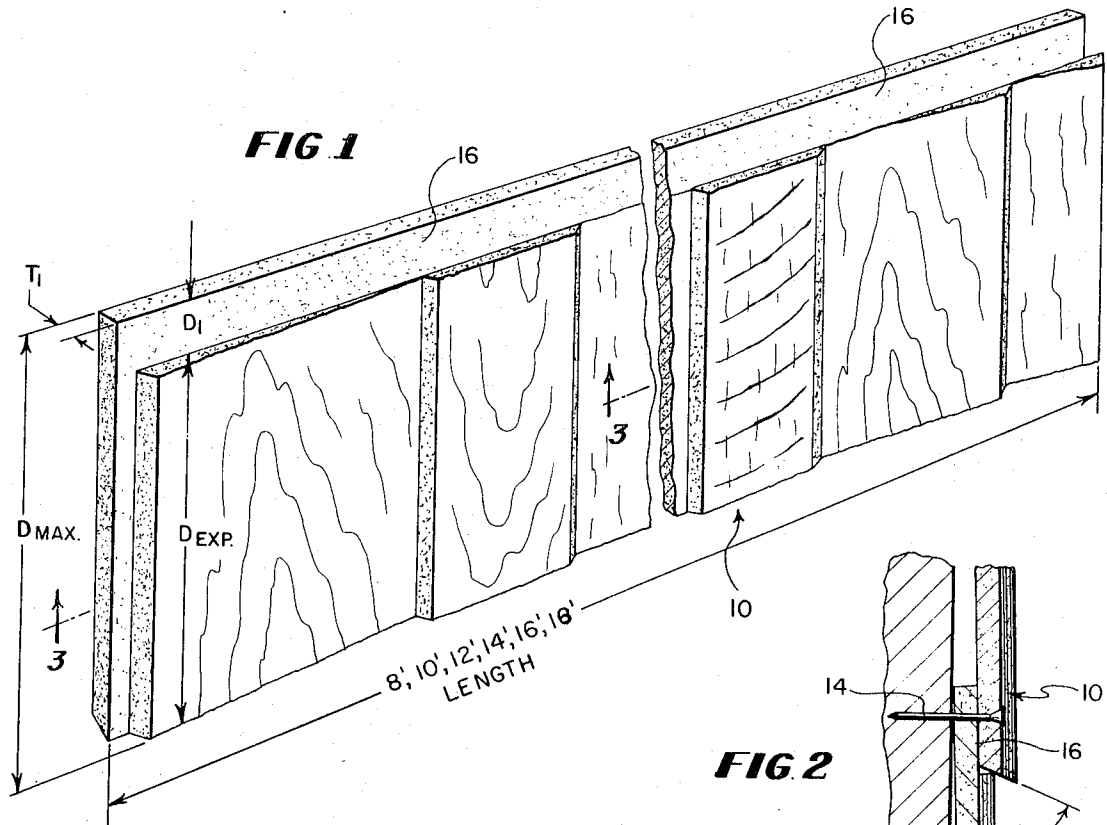

INVENTORS:
CHARLES M. HANLON
ALLAN J. LUCK

BY *Mason Kolchman*
Kathman & Wyss
ATTORNEYS

March 12, 1974

C. M. HANLON ET AL

3,796,586

DEEP EMBOSSED, SHINGLE LAP SIDING

Filed Sept. 8, 1971

2 Sheets-Sheet 2

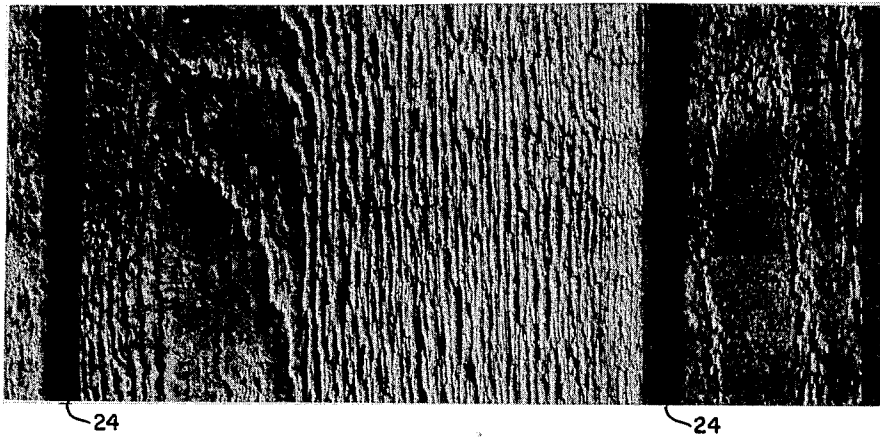

FIG. 5

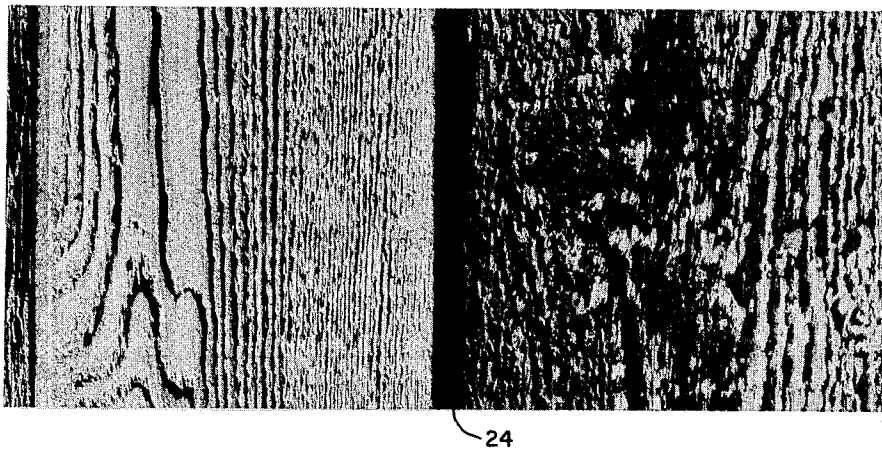

FIG. 6

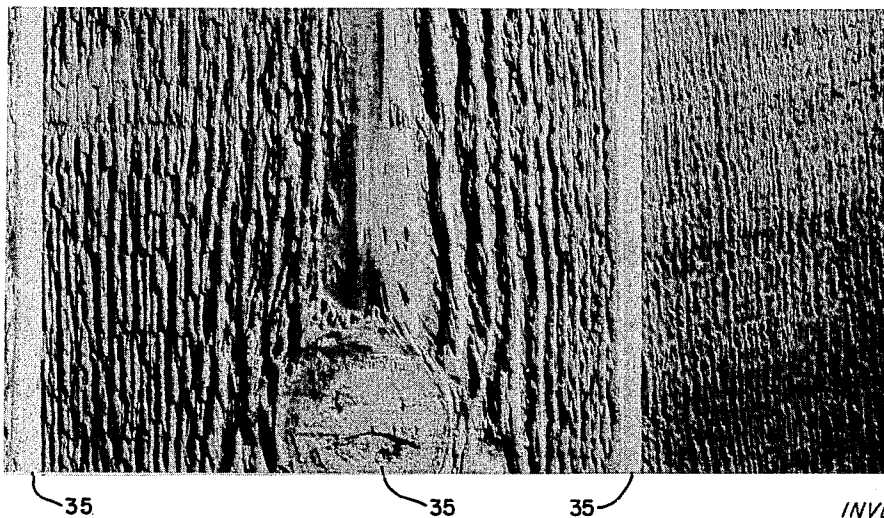

FIG. 7

INVENTORS:
CHARLES M. HANLON
ALLAN J. LUCK

BY *Mason, Koldman, Rathburn & Wyss*
ATTORNEYS

1

3,796,586

DEEP EMBOSSED, SHINGLE LAP SIDING

Charles M. Hanlo, Addison, and Allan J. Luck, Marengo, Ill., assignors to Masonite Corporation, Chicago, Ill.

Filed Sept. 8, 1971, Ser. No. 178,556

Int. Cl. B44d 1/26

U.S. Cl. 117-8

5 Claims

ABSTRACT OF THE DISCLOSURE

A deep embossed, shingle lap siding for building wall and roof structures formed of compressed wood fibers having an uneven, deep embossed surface on one side comprising high and low portions and resembling wood shingles. A first coating of coloring or tinting agent is applied only on selected portions of said uneven surface and thereafter a second coating of coloring or tinting agent is applied over substantially the entire uneven surface, thereby providing an appearance of stained wood shingles.

The present invention is directed toward a new and improved, deep embossed, shingle lap siding having the appearance of stained wood shingles for use in siding walls and roofs of building structures, and the like. The lap siding is formed of compressed wood fibers and is manufactured in relatively thin, wide elongated sheets for easy and rapid installation with a minimum of labor. The lap siding may be applied directly on the sheathing or underlayment of a building wall or roof structure.

In recent years in residential home building and in commercial building as well, the use of stained cedar shakes and shingles as a siding or roofing material has grown in popularity. In addition, the use of vertical and horizontal, rough sawed, prestained cedar siding has increased substantially. Hand-split cedar shakes and shingles are elegant in appearance but have major drawback in requiring a high rate of man hours of installation labor per unit area of surface covered. Moreover, if the shakes or shingles are not prestained or painted before installation it is a difficult and time-consuming job to apply wood preservatives, such as paints or stains, although in many instances the shingles are left in their natural state because of the ability of cedar to withstand the weather and elements without substantial deterioration for a long period of time. Because of the uneven surface and the substantial differences in thickness of the hand-split cedar shakes, the appearance of a wall or roof surface is boldly in relief and includes deep shadows and darkened areas as well as lighter and somewhat glossy areas, giving a pleasant appearance with much contrast and relief. In addition, because the growth rate of trees varies between summer and winter upon staining or painting, cedar shakes appear to have some areas or regions of graining wherein the stain or paint is absorbed rapidly leaving a rather dull appearance. In other graining areas, however, the stain or paint is not absorbed so completely and gives a much glossier or highlighted appearance. These differences in appearance between graining areas highlight and beautify the overall aesthetic value of painted or stained wood shingles or shakes and have made them extremely popular as covering materials for buildings.

It is therefore an object of the present invention to provide new and improved lap siding material for building structures.

Another object of the present invention is to provide a new and improved, deep embossed, lap siding similar in appearance to shingles or shakes.

Another object of the present invention is to provide a new and improved, deep embossed lap siding which, when installed, is similar in appearance to wood shingles or shakes but which requires much less labor to install.

2

Another object of the present invention is to provide a new and improved, shingle-type lap siding formed of compressed wood fibers and having a deep embossed, uneven surface on one side which is substantially similar in appearance to a building wall or roof surface covered with wood shakes or shingles.

Another object of the present invention is to provide a new and improved, deep embossed, shingle-type lap siding formed of compressed wood fibers having an uneven surface on one side including portions having a dull appearance and other portions somewhat more glossy in appearance similar to actual stained or painted wood shingles or shakes.

Another object of the present invention is to provide a new and improved, deep embossed lap siding of a character described having a rough appearing outer surface which is substantially identical in appearance to stained or painted cedar shakes or shingles.

Still another object of the present invention is to provide a new and improved, shingle-type lap siding having a deep embossed, uneven, outer surface substantially similar in appearance to shingles or shakes and having high and low portions with substantial depth or relief between these portions.

Another object of the present invention is to provide a new and improved, deep embossed lap siding of the character described wherein high and low portions of the deep embossed outer surface are interconnected by a narrow strip of surface area having an angle of approximately 35 degrees with respect to the adjacent high or low surface portions.

Still another object of the present invention is to provide a new and improved deep embossed, shingle-type lap siding of the character described having a ratio between a minimum thickness portion and a maximum thickness portion of approximately 60 percent.

Another object of the present invention is to provide a new and improved lap siding having a deep embossed outer surface portion with maximum and minimum thickness sections having a difference in thickness up to approximately $\frac{3}{16}$ inch.

Still another object of the present invention is to provide a new and improved lap siding of the character described wherein the deep embossed, uneven outer surface includes portions having a dull or dark appearance in contrast to other portions having a shinier or somewhat glossy appearance.

Another object of the present invention is to provide a new and improved, shingle-type lap siding having an undercoat of color or tinted coating material applied to portions of the uneven outer surface thereof followed by the application of an outer layer of color coating applied over the entire outer surface.

Another object of the present invention is to provide a new and improved method of manufacturing a deep embossed, shingle-type lap siding of the character set forth in the foregoing objects.

Another object of the invention is to provide a new and improved method of making a shingle-type lap siding having a deep embossed, outer surface wherein a first coating of liquid coloring or tinting agent is applied to selected surface portions of the outer surface and, subsequently, a second outer coat of coloring or tinting agent is applied over the entire outer surface of the side, thereby developing an appearance similar to actual shakes or shingles as installed on a wall, roof, or other portions of a building structure.

Another object of the invention is to provide a new and improved method of the character described wherein only selected portions of the outer surface of the siding are covered with a first coating of liquid coloring or

tinging agent prior to the application of a second coating applied over the entire surface thereafter.

Another object of the present invention is to provide a new and improved method of manufacturing deep embossed, shingle-type lap siding of the character described when the outer uneven surface is accomplished by the application of two coats of coloring or tinting agents, the first coat covering only a portion of the total surface while the second coat is applied over the entire outer surface of the siding.

The foregoing and other objects and advantages of the present invention are accomplished in a new and improved lap siding for wall or roof structures which is formed of compressed wood fibers and is provided with a deep embossed, outer surface appearing like actual wood shingles or shakes laid in place. A first coating of coloring or tinting agent is applied only on selected portions or parts of the surface and, subsequently, a second coating of compatible coloring or tinting agent is applied over the entire outer surface, thereby providing a lap siding substantially similar or identical in appearance to wood shakes or shingles as laid in place.

In accordance with the method of the present invention, the deep embossed, shingle-type lap siding is formed by compressing moisturized wood fibers into a thin sheet with a die plate mounted on a hydraulic press. The die forms a deeply embossed outer surface of the lap siding having high and low portions in relief, giving an appearance similar to a roof or wall structure formed of shingles or shakes. After the outer surface is embossed, a first coating of coloring or tinting agent is applied onto selected portions of the uneven outer surface and, subsequently, a second coating of compatible coloring or tinting agent is then applied over the entire outer surface.

For a better understanding of the invention, reference should be had to the following detailed description taken in conjunction with the drawings, in which:

FIG. 1 is a perspective view of a new and improved, deep embossed, shingle-type lap siding constructed in accordance with the features of the present invention;

FIG. 2 is a vertical sectional view of a roof or wall structure illustrating how the lap siding is installed thereon to provide the appearance of wood shingles or shakes;

FIG. 3 is a cross-sectional view taken along lines 3—3 of FIG. 1 illustrating the deep embossed character of the lap siding;

FIG. 4 is a schematic diagram illustrating in somewhat animated fashion a method in accordance with the present invention wherein the application of a first coating of coloring or tinting agent is provided only over portions of the outer surface of the lap siding;

FIG. 5 is a photograph illustrating the deep embossed, uneven, outer surface of the lap siding of the invention after it is pressed to shape but prior to the application of a first coating of coloring or tinting agent;

FIG. 6 is a photograph of the outer surface of the lap siding of the invention after application of a first coat of tinting or coloring agent on the higher portions thereof; and

FIG. 7 is a photograph of the outer surface of the lap siding in accordance with the present invention after a second or outer coating of coloring or tinting agent has been applied.

Referring now more particularly to the drawings, FIGS. 1, 2 and 3 illustrate a new and improved, deep embossed, shingle-type lap siding constructed in accordance with the features of the present invention and referred to generally by the reference numeral 10. As illustrated in FIG. 2, the lap siding 10 is formed in long, thin strips and is adapted to be rapidly installed on a wall or room structure onto conventional sheathing or underlayment 12 with typical fasteners, such as nails 14. A marginal tongue or upper edge portion 16 of uniform thickness T_1 and vertical depth D_1 is formed along the upper edge of the lap siding 10 in order to form a weather-tight seal against a lapped over, lower, marginal edge portion of the next

upper siding strip, as shown in FIG. 2. The lower edges of the siding strips are undercut at an angle A, as shown in FIG. 2, in order to provide for good drainage of water or precipitation from each upper siding strip to the next lower when installed in lapped fashion, as shown on a roof or wall structure. The individual strips of lap siding 10 are provided in a convenient standard size, for example, they may have an overall depth D_{max} , of up to 12 inches or more, and the siding strips may come in foot lengths of 8, 12, 16, etc., or intermediate lengths, as desired. The lap siding sheets are easily sawed to any length or depth in a conventional manner with a common wood saw.

It is usually desirable to provide relatively long strips of siding in order to minimize the costs of labor for installation. The maximum vertical depth of the siding strips 10 less the marginal depth D_1 along the upper edge provides an exposed face measured as depth D_{exp} , which is exposed to the weather, and this depth can be standardized as for typical siding materials of 4, 5, 6, 7, 8, 9, 10, or even 12 inches, as desired.

In accordance with the present invention, the outer surface exposed to the weather face of the lap siding strips 10 are formed with a deeply embossed imprint thereon, which imprint is substantially identical in appearance to actual wood shingles or shakes as laid in place on a wall or roof structure. Viewing FIG. 1, it will be seen that the outer surface of the lap siding 10 contains deep depressions, as at the edges of individual shingles, as well as shallow depressions of wood grain variations. Moreover, deep relief in the uneven surface provides dull or dark portions in contrast to more glossy or lighter portions. In forming the lap siding, the raw material comprises wood fibers which are obtained from wood chips which have been heated in the presence of high pressure steam within a closed vessel. By means of a large valve in the steam-heated pressure vessel, the pressure is rapidly reduced (almost an explosive decompression), and this causes the wood chips to literally explode or expand into a plurality of individual stringy fibers. These fibers are then placed in a "Fourdrinier" type, paper-making apparatus wherein a thick wet mass of fibres (approximately 2 to 2½ inches thick) is formed and moved on a gentle upslope from below to above a liquid level in a surrounding liquor tank. The mass or thick blanket of wet, fibrous, cellulose material is moved into a hydraulic press and is supported by a screen in order to let out moisture when a large die or plate having the desired deep embossed imprint thereon for providing the deep-drawn relief and rough, uneven, outer surface, as shown in FIG. 7, is brought rapidly downwardly under high pressure to compress and squeeze the fibers into a dense board. Upon compression, the excess water is expelled through the screen and the result is a thin, dense, hardboard lap siding strip 10, as shown in FIG. 1, having a wood shingle-like, deeply embossed outer face, as illustrated in FIG. 5.

Referring to FIG. 3, prior to the present invention it has been a problem that on deep drawing or embossing of matted fibrous boards or sheets at sharp angles in the minimum thickness portions or regions, excess fiber concentration developed, and these appeared as dark areas on the board surface adjacent the areas designated T_{min} . The heavy compression and concentration of the fibers formed these heavy, dark, tough, and more dense regions, which regions reacted to painting or other coloring material differently from other, more normal, portions of the board wherein the fiber concentration is less and the density is more near average for the board as a whole. Moreover, at the maximum thickness regions, as labeled T_{max} , it was found in prior art applications that if the drawing angle B is too sharp or acute, the fibers, instead of conforming to the die shape, begin to tear off or break open leaving their exposed ends of fibers along the corners. These fiber ends soak up paint or other tinting or coloring agent much more rapidly than the other portions of the siding and act similar to an ink blotter. More-

over, both the valleys and ridges in prior art boards provide an unnatural appearance on the surface of the siding and make finishing the siding difficult.

In accordance with the present invention, it has been found that a flat surfaced, beveled, narrow strip, as indicated by the numeral 24, may be used for transition between the thicker and thinner sections of the lap siding board 10 in a manner eliminating the problems referred to in connection with the prior art. The narrow transition strips 24 have been found to work well when the strips are oriented or tapered at an angle B of approximately 35 degrees with respect to adjacent outer faces 26 or 28 of the thinner and thicker section portions of the lap siding. The angle B of 35 degrees has been found to be a median acceptable relief or deep drawing angle and problems of excess fiber concentration in the valleys 22 or a fiber breakage and end exposure in the ridge areas 23 are eliminated. Moreover, it has been found that deep relief or drawing can be readily accomplished with the narrow strips 24 being flat and having an angle intersection of approximately 35 degrees with respect to the adjacent outer faces of the thin and thicker sections of the siding. The amount of relief or maximum drawing depth is represented as the difference between $T_{max.}$ and $T_{min.}$, and it has been found that deep drawing or embossing, wherein the depth is approximately 40 percent of $T_{max.}$, is suitable using flat surface (rather than rounded), narrow transition strips 24 at a drawing angle B of about 35 degrees.

In a commercial embodiment of the present invention, the lap siding 10 has a maximum thickness $T_{max.}$ of approximately $\frac{7}{16}$ inch and the drawing depth or difference between the maximum and minimum thickness $T_{min.}$ is about $\frac{3}{16}$ inch or roughly 40 percent of the maximum thickness of the pressed hardboard. Stated alternatively, a minimum board thickness for providing good board quality with no tearing or fiber compression stress problems along the corners of the deep draw has been found to be about 60 percent of the maximum thickness of the board.

The inside or back surface of the lap siding strips 10 is planar and may have the imprint of the supporting screen therein which is formed during compression of the fibers against the screen in the hydraulic press during the deep embossing process of board formation.

As shown in FIG. 5, the narrow transition strips 24 between adjacent thick and thin board sections show up as relatively dark areas, but there is no appreciable fiber tearing or breakage along the convex junction between the maximum thickness portions and the transition strip. Moreover, there is no excessive fiber compression at the junction between the minimum thickness sections of the surface portion and the narrow transition strip 24. In both instances it is felt that the angular orientation of the strips at approximately an angle B of 35 degrees along with the maximum drawing depth of approximately 40 percent of the maximum board thickness is an important factor in elimination of the problems. It will also be apparent from FIG. 5 that the deep embossed uneven outer surface of the lap siding is substantially identical in texture relief and appearance to wood shingles or shakes. The surface shows wood grain variations and preferably the die is constructed from a pattern of actual wood shingles or shakes so that the graining and relief effect is completely authentic.

In accordance with the present invention, after the lap siding boards 10 have been formed by pressing into shape with a deeply embossed outer surface, as shown in FIG. 5, the green boards are cured in order to remove excess moisture therefrom and to set the resinous bonding between the wood fibers in the hardboard. The siding boards 10 are then finished in accordance with the present invention, to produce a final product, as shown in FIG. 7, which appears substantially identical to actual wood shingles or shakes as normally laid in place.

Referring to FIGS. 4, 6, and 7, the cured lap siding

boards 10 are passed under one or more paint, stain, or tinting agent applicator rolls generally indicated by the numeral 30. The boards are supported on suitable conveying means generally indicated by the number 32. The applicator rolls are provided with a compressible outer surface covering 34 of rubber or the like for holding liquid paint, stain, or tinting agent for contact application to the uneven, deeply embossed outer surface of the lap siding which is passed under the rolls in the direction of the arrow C. The liquid paint, stain, or tinting agent is supplied from liquid troughs 36 and is delivered by a first pickup roll 38 which deposits a desired layer of thickness or volume of the liquid onto the surface of main transfer roller 40. The transfer roller 40 runs in contact with the applicator roll 30 and transfers a precisely controlled thickness of coloring agent onto the surface of resilient material 34 of the applicator rolls. The transfer is effected to the roll surface 34 at point D and, as the applicator roll rotates in the counterclockwise direction, as shown by the arrow E, the paint, stain or tinting agent in liquid form is pressed into contact with the deep embossed upper surface of the pressed fiberboard lap siding passing beneath the roll. The amount of thickness of the coloring coat depends upon a number of factors including the viscosity of the liquid, the appearance desired, the contact pressure, etc. Accordingly, precise control of the amount of paint, stain, or other tinting agent applied onto the surface 34 of the applicator rolls 30 for eventual application to the surface of the lap siding 10 is required. The applicator rolls 30 are movable toward and away from the siding board 10, as indicated by the arrow F, to increase or decrease the contact pressure between the deeply embossed surface of the lap siding boards and the liquid dispensing outer cover of the roll.

In accordance with the features of the present invention, a first or partially covering "kiss" coat of paint, stain, or tinting agent is applied onto the higher or greater thickness portions of the lap siding boards 10 by positioning the rolls 30 upwardly relative to the path of travel of the siding thereby decreasing the contact pressure between the rolls and the surface of the boards. This adjustment is set up so that only a fraction or portion of the total surface area is covered on the passage of the siding beneath the applicator rolls. The resultant coloring application is thus applied only on the higher or thicker portions of the siding boards while the thinner sections or valleys are skipped.

After the first "kiss" coating is applied, the siding appears as shown in FIG. 6, wherein the right hand or minimal thickness sections of the siding are left substantially uncovered while the left-hand or thicker portions of the siding are fully covered. As viewed in FIG. 4, the pressure between the applicator roll 30 and the upper surface of the siding is adjusted by movement of the rolls in a direction toward or away from the siding boards 10 and, as shown by the dotted median line G, surface portions on the uneven outer surface of the siding board below the median line are left uncovered while surface portions above this line are fully covered and completely coated. It will be seen that some portions are covered with a heavier or thicker coating than others because of the compressible nature of the roll covers 34 and the uneven nature of the siding surface.

After the application of the first or partially covering "kiss" coating as described, one or more additional coatings of compatible paint, tint, or stain are applied, and these additional, fully covering coatings may be applied with the same applicator rolls 30 after adjustment to move the rolls closer towards the surface of the lap siding to increase the contact pressure so that substantially the entire area of the rough outer surface of the lap siding is covered.

Preferably, the final or fully covering finish coating of paint, stain, or tinting agent is applied by apparatus as shown in FIG. 4 including a liquid trough 42 having a weir or dam wall 43 over which a flow of liquid is maintained to flood the lap siding boards. The liquid agent flooding

over the entire uneven outer surface of the lap siding boards from the trough 42 is then evened out on the siding boards by forced air supplied through an elongated nozzle structure 44 together with the action of a rotary brush 46. This procedure insures a full coverage of the deeply embossed, uneven outer surface of the boards, thereby providing excellent weather resistant characteristics. If desired, several additional coats may be applied.

It will be seen from FIG. 7, which illustrates the finished product, that certain portions 35 on the outer surface of the lap siding appear somewhat different from others. These surface portions are those covered by both the first coat and one or more additional coats and the resultant finished product closely, if not almost identically, resembles the appearance of stained or painted natural wood shingles or shakes as applied on a roof or wall structure. It is clearly evident from the differences between photos of FIGS. 5, 6, and 7 that the finished product shown in FIG. 7 closely resembles actual wood shake or shingles, whereas the uncoated lap siding shown in FIG. 5 is discernable as an artificial product.

The true resemblance of actual wood is brought about by the unique combination of staining, painting, or tinting the roughened outer surface of the lap siding in the manner aforesaid with a first "kiss" coating covering only the portions of higher or greater thickness on the outer surface which is followed by one or more second coating applications completely covering the surface. This technique, in combination with the unique, deep embossed, uneven outer surface with wood grain effect provides a finished lap siding product which is highly aesthetic in appearance and which is rapidly installed in a fraction of the time required to install individual wood shakes or shingles. The finished product not only is authentic in appearance but is long lasting under severe weathering and because of the prefinished coating procedure reduces labor for painting. Installed, the lap siding 10 is relatively low in cost and presents an appearance identical to that of much more expensive building materials.

While there has been illustrated and described a single embodiment of the present invention, it will be appreciated that numerous changes and modifications will occur to those skilled in the art, and it is intended in the appended claims to cover all those changes and modifications which fall within the true spirit and scope of the present invention.

What is claimed as new and desired to be secured by Letters Patent of the United States is:

1. A relatively thin sheet of building material formed of compressed wood fibers having an uneven surface on one side embossed in a pattern substantially identical in appearance to wood shingles laid in place, said uneven surface defining high and low portions, and including narrow strips adjoining adjacent pairs of high and low portions, said strips intersecting adjacent surfaces of said high and low portions at an angle of approximately 35 degrees with some of said wood fibers extending transversely across the junction of said strips and the adjacent surface of said high and low portions deflected a maximum angle of approximately 35 degrees across said junction, a first coating of dryable coloring liquid applied to at least parts of said high portions of uneven surface and a second coating of dryable coloring applied over substantially all of said uneven surface after said first coating is substantially dry.

2. The sheet of building material of claim 1 wherein said low portions define therein minimum thickness sections of said sheet and said high portions define therein maximum thickness sections.

3. The sheet of building material of claim 2 wherein said uneven surface includes narrow strips adjoining adjacent pairs of high and low portions, said minimum thickness sections defined along the juncture of said strips and an adjacent low portion.

4. The sheet of building material of claim 3 wherein the ratio between said minimum thickness and said maximum thickness is approximately 60 percent.

5. The sheet of building material of claim 4 wherein the maximum difference in thickness between said minimum thickness sections and said maximum thickness sections is approximately $\frac{3}{16}$ inch.

References Cited

UNITED STATES PATENTS

366,286 7/1877 Wood ----- 117—8

WILLIAM D. MARTIN, Primary Examiner

T. G. DAVIS, Assistant Examiner

U.S. Cl. X.R.

52—313; 117—11, 45, 76 R