

Distributed by: BEST MATERIALS LLC
Ph: 800-474-7570, 602-272-8128 Fax: 602-272-8014
www.BestMaterials.com Email: Sales@BestMaterials.com

Flashing Tapes Manual:

Flashing Perimeter Building Openings in Frame Construction

Polyken® 626-35 Foilastic
Polyken® 627-35 Shadowlastic
Nashua® 626-20 Optiflash
Nashua® 627-20 Optiflash
Nashua® 697-40 Contour™

October 2007, 2nd Edition
January 2001, 1st Edition



Flashing Tapes Manual: Flashing Perimeter Building Openings in Frame Construction

Table of Contents

Title	Section
Introduction	1.0
Product Data	2.0
Polyken® and Nashua® Flashing Tapes	
General Application	3.0
Window / Door / Skylight Flashing Application	4.0
Detail Selection	5.0
Flashing Sequence Diagrams	6.0
Contour™ Flashing Sequence Diagrams	7.0
Guide Specification (07650 Flexible Flashings)	8.0
Polyken® and Nashua® Flashing Tapes	
Technical Bulletins	9.0
Material Safety Data Sheets (MSDS).....	10.0

Introduction

Polyken® and Nashua® Flashing Tapes

Self Adhering Flashing (SAF) is the generic term used to describe a flexible, sheet membrane products with a self-adhering adhesive used for waterproofing purposes in building construction.

SAF products are used for general building envelope flashing purposes which can include above grade walls, window and door openings, skylights and roofing.

The net thickness for SAF can vary from 20 mil to 60 mil. The 40 mil and 20-25 mil thicknesses are the two general products used typically.

Where a single strip or piece of SAF can be used, the 40 mil thickness is recommended. Where multiple layers may cause an unwanted build-up of thickness that interferes with other construction tolerances, then the 20-25 mil product can be used.

Butyl versus Asphalt

There are two basic types of adhesive used for self adhering flashings—SBS asphalt and butyl. Asphalt is cheaper than butyl so may be selected where material cost alone is deemed critical.

Butyl performs with a wider range of in-service temperatures (-35°F - 200°F). Asphalt can bleed with high or prolonged heat exposure. Butyl typically has better initial and long-term substrate adhesion than asphalt.

Butyl rubber adhesive contains no volatile organic compounds (VOC), thus the adhesive system does not react with

caulking and sealants typically used in conjunction with flashing tapes.

SBS asphalt adhesive formulations contain VOCs that can react chemically with the solvents used in caulking and sealants causing both materials to break down and flow.

Reference Manual

This product publication can serve as a complete reference for the specification, detailing, and installation of Polyken® and Nashua® Flashing Tapes. Each section is independent and can be used as a separate document to meet specific needs.

This publication has been developed as a practical and useful technical reference for the building construction industry. The publication includes several sections: a Product Data sheet for designers and building owners; Application Guides for builders; Details for designers; Sequence Diagrams for installers; and a Guide Specification for specifiers.

Product Data Sheet

The product data follows the CSI Spec-Data format. It is intended as a reference of material and performance information for Polyken® and Nashua® Flashing Tapes.

Application Guides

Two application guides exist for Polyken® and Nashua® Flashing Tapes. One is a general flashing guide and the other is a specific guide for flashing windows, doors and skylights.

General Flashing

The general flashing application guide outlines the use of Polyken® and Nashua® Flashing Tapes as a multi-purpose flashing membrane for building construction needs. Guidance for installing Polyken® and Nashua® Flashing Tapes with different techniques is provided.

Windows, Doors and Skylights

The Window/Door/Skylight application guide covers the different types of window/door frame materials and different wall cladding materials, such as, stucco, wood and vinyl sidings. The flashing procedures in the details and sequence diagrams are not specific to a particular window/door/skylight product nor are they restricted to particular wall cladding materials. This application guide notes how to handle the unique features that vary from product to product for different window/door frames and wall cladding types.

Flashing Details

The Flashing Details section provides a consistent format for details. The detail pages include a reference diagram of a door, window or skylight with detail section cuts shown for the top, sides and bottom. Detail sections are the standard format used on building plans to show construction assemblies. The flashing details are intended as a reference for designers.

The window/door details address nail-on or flanged frames. Flashing block frames (non-finned) are briefly addressed in the Polyken® and Nashua® General Flashing Application Guide (see Part 3).

The flashing details for windows, doors and skylights shown are for frame construction and substrates.

Windows/Doors

The ASTM E2112-07 Standard Practice for the Installation of Windows, Doors and Skylights describes four methods of applying flashing strips to windows and doors. These methods are A, B, A1 and B1.

Method A

Jamb flashing applied over the window/door frame. Building paper is used as the weather-resistant barrier and is applied after the window/door installation.

Method A1

Jamb flashing applied over the window/door frame. Building paper or house wrap is used as the weather-resistant barrier and is applied before the window/door installation.

Method B

Jamb flashing applied under the window/door frame. Building paper is used as the weather-resistant barrier applied after the window/door installation.

Method B1

Jamb flashing applied under the window/door frame. Building paper or house wrap is used as the weather-resistant barrier applied before the window/door installation.

Within the ASTM Standard, Methods A & A1 refer to the use of self-adhering, flexible membranes as an alternative to conventional paper-based flashings. In this publication, Methods A & A1 are shown using Polyken® and Nashua® Flashing Tapes as the primary flashing material.

The ASTM standard for Methods B & B1 around building opening perimeters is not shown in this reference. Methods B & B1,

follow conventional flashing procedures, where the perimeter flashing is applied before the window or door frame. Polyken® and Nashua® flashing tapes can be used in Methods B & B1, if the ASTM standard is followed.

In addition to the ASTM flashing methods, this publication includes an alternate flashing method which has been designated Method SAF. This window/door flashing procedure takes best advantage of the use of Polyken® and Nashua® Flashing tapes.

Method SAF is not illustrated in the ASTM standard, but is based on a combination of ASTM Methods A plus Method B. Polyken® and Nashua® Flashing Tapes can be used instead of sealant under the fin around the opening, as required with the ASTM Methods A, A1, B & B1. Method SAF eliminates the need to use sealant and is less messy for installers. However, the use of sealant under Nail-Fin installations decreases the risk of leakage due to workmanship or material variability.

Skylights

There are four types of skylights categorized by the ASTM E2112 Standard. All of these skylight types have one flashing method which relies on roofing mastic to seal the skylight frame to the roof substrate. This publication presents another flashing method using Polyken® and Nashua® Flashing Tapes instead of mastic to seal the perimeter opening. The ASTM standard neglects to mention the use of flexible, self-adhering membranes for skylight flashings, although they are commonly used by roofers and builders for roof flashing purposes.

Flashing Sequence Diagrams

In order to assist the installer in how to flash building openings, this Polyken® and

Nashua® application guide presents step-by-step flashing sequence diagrams. The flashing sequence diagrams show how to install a window, door or skylight with matching descriptions. All of the methods of flashing are shown with each flashing detail.

An introductory exploded view shows all the materials that go into flashing the typical opening. This overall view of the parts of the flashing assembly provides a quick way of comparing methods. The materials used in the flashing assembly and the differences in the application sequences can be used as a basis for the selection of the flashing method.

Window Flashing

Self adhering flashing (SAF) can be used in all the ASTM E2112 methods. In addition, SAF can be used uniquely in the method SAF shown, which combines Methods A + B or Methods A1 + B1.

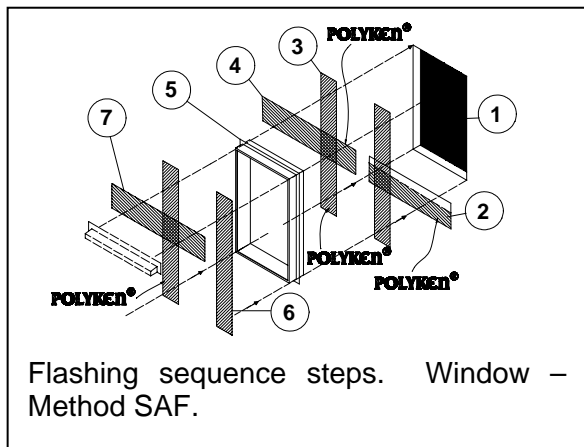
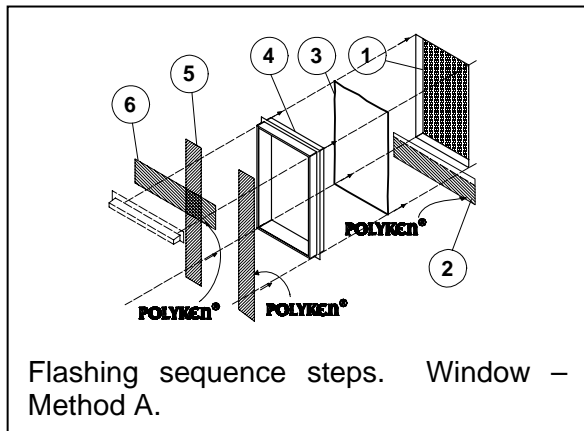
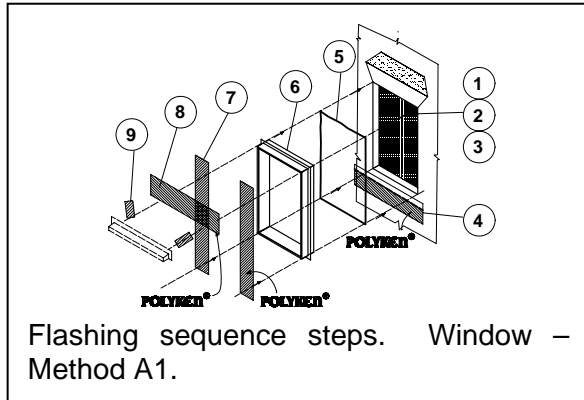

Door Flashing

Self adhering flashing (SAF) can be used in all the ASTM E2112 methods. In addition, SAF can be used uniquely in method SAF shown which combines Methods A + B or Methods A1 + B1

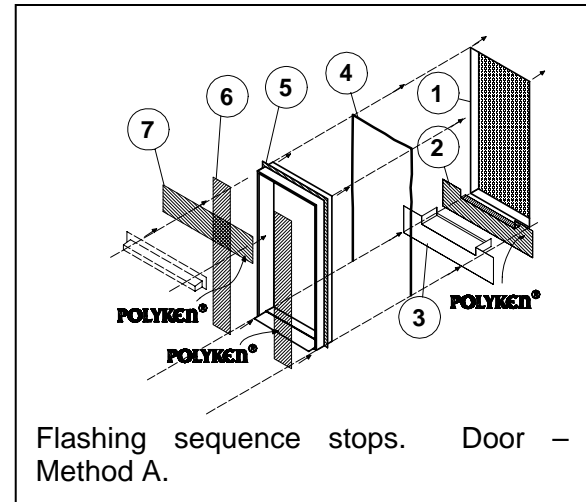

Methods B, A1 & B1 are similar to the window flashing.

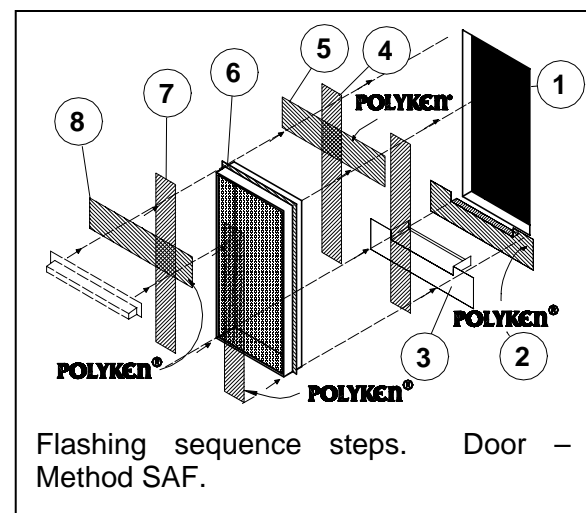

Skylight Flashing

There are four types of skylights designated by ASTM E2112. Self adhering flashing can be used for all types of skylights. Two methods shown here are suitable for two pairs of skylights types.

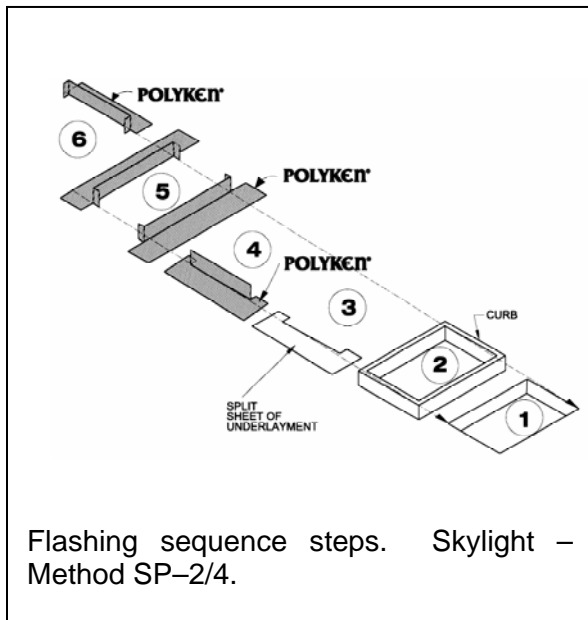
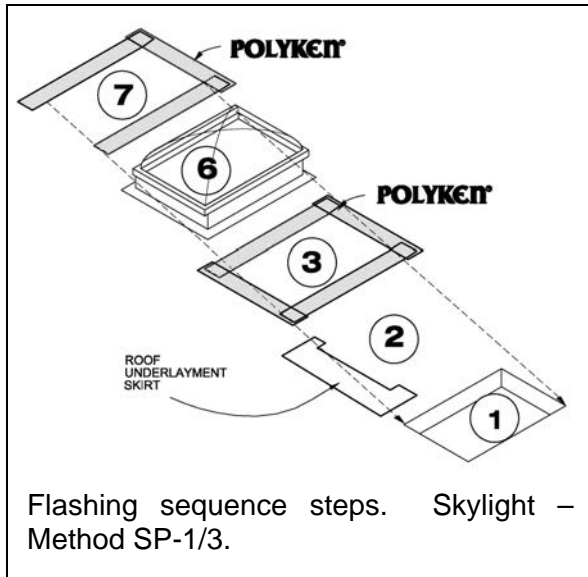

Method SP-1/3 applies to skylight types 1 and 3. Method SP-2/4 applies to skylight types 2 and 4.

See Manual Section 5.13 for skylight flashing details.

Guide Specification

The guide specification provides detailed recommendations for both the 35 mil and 20 mil Polyken® and Nashua® Flashing Tape products. This guide specifications can be utilized to prepare architects' or designers' specifications whenever project specifications are provided as part of a set of building design documents.

Disclaimer

The information contained in this publication is intended as a reference for architects, designers, and contractors outlining the application of Polyken® and Nashua® Flashing Tapes for use as perimeter flashing around windows, doors and skylights.

Specific products, building construction, and particular project conditions vary and may require changes in flashing techniques and selection of products. Final decisions on the use of this information are not the responsibility of Covalence Adhesives.

This publication does not intend to supersede or be used in lieu of project-specific requirements issued by design professionals, building regulations, or product manufacturers.

This information should be recognized as recommendations which, if followed with professional judgment, should result in successful performance.

1. PRODUCT NAME

POLYKEN® Foilastic™ 626-35
Flashing Tape

POLYKEN® Shadowlastic 627-
35 Flashing Tape

Nashua® 626-20 Optiflash
F20

Nashua® 627-20 Optiflash
B20

Nashua® Contour 697-40

2. MANUFACTURER

Berry Plastics Tapes and
Coatings Division

25 Forge Parkway

Franklin, MA 02038

Phone: 1-800-248-7659

Fax: 1-800-328-4822

Website: www.berryplastics.com

3. PRODUCT DESCRIPTION

Basic Use: Polyken® and Nashua® and 626 foil-faced and 627 polyethylene-faced butyl rubber-based adhesive-coated flashing tapes are used to prevent moisture and water entry into buildings.

Polyken® and Nashua® 626 and 627 are primarily used for perimeter flashings around window, door, and skylight openings, and for other general flashing uses including roofing applications.

Precautions and Limitations: Polyken® and Nashua® 626 and 627 can be applied directly to most building sub-strates e.g., plywood, galvanized sheet metal, asphalt-saturated building papers/felts.

For rough surfaces or textured materials, such as OSB, gypsum board, concrete, masonry and fiberglass-mat surface sheathing, it is recommended that a primer, i.e., Polyken® 1027, be used to promote adhesion between flashing tape and substrate.

Polyken® and Nashua® have an application temperature range of 20°F – 180°F and a service temperature range of -35°F – 200°F

Polyken® and Nashua® Flashing Tapes will withstand exposure to direct sunlight for extended periods. While the Polyken® Shadowlastic, Nashua® Optiflash B20 and Nashua® Contour will resist UV degradation for up to one year, the Polyken® Foilastic and Nashua® Optiflash F20 can be exposed to ultraviolet light indefinitely.

Polyken® and Nashua® 626 and 627 can become slippery when covered by moisture or frost.

Composition and Materials: Polyken® and Nashua® 626 and 627 Flashing Tapes are designed to be cold-applied, self-adhering flashings with strong and immediate adhesion to wood, metal, concrete and masonry surfaces. Both the polyethylene and foil facings with the butyl rubber-based adhesive combine to provide a tough, conformable moisture barrier.

Polyken® and Nashua® 626 and 627 flashing tapes exhibit excellent low temperature flexibility and adhesion properties and will not flow at elevated temperatures. Polyken® Foilastic and Shadowlastic have a non-moisture absorbent polyethylene release liner. Nashua® Contour, Optiflash F20 and Optiflash B20,

have a moisture stable poly-coated kraft release liner, both designed for easy release.

4. TECHNICAL DATA

Polyken® and Nashua® 626 and 627 Flashing Tapes conform to the physical properties as stated in Tables 1, 2, and 3.

Applicable Standards: Polyken® and Nashua® 626 and 627 Flashing Tapes meet the requirements of the following specifications:

Electronic SPEC-DATA®

SPEC-DATA® II

Sweets Architectural Catalog

MASTERSPEC Section 07650

Flexible Flashing.

5. INSTALLATION

Surface Preparation: Polyken® and Nashua® 626 and 627 Flashing Tapes are designed to be applied directly on plywood, metal, or masonry substrates. Remove any dust, dirt, nails or other objects from the substrate before applying the flashing to new construction.

Priming: Concrete or masonry surfaces can be primed with Polyken® #1027 Primer, following manufacturer's instructions. Refer to Table 4 for product information.

Priming, however, does increase the overall adhesion on steel and wood surfaces even though it is usually not necessary under normal circumstances.

Temperatures: Apply Polyken® and Nashua® 626 and 627

Flashing Tapes in fair weather at temperatures of 25°F or higher. The adhesive will not flow at elevated temperatures.

Flashing Application: Surfaces should be dry and free of dust, dirt or other foreign matter. For positive drainage flow begin flashing application at the low point of a wall or sloped roof deck. Overlaps should be a minimum of three inches. All membrane edges and overlaps should be hand rolled.

6. AVAILABILITY AND COST

Availability: Polyken® and Nashua® 626 and 627 Flashing Tapes are available from strategically located warehouses and from a network of distributors ensuring prompt delivery throughout the United States.

Cost: Polyken® and Nashua® 626 and 627 Flashing Tapes are competitively priced. Contact a local Polyken® or Nashua® representative for specific cost information.

7. WARRANTY

Polyken® and Nashua® Flashing Tapes are warranted to be free of defects in manufacturing. Contact Berry Plastics for specific information regarding the 12-year limited warranty.

8. MAINTENANCE

No maintenance is required for Polyken® and Nashua® 626 and 627 Flashing Tapes if the installation has been in accordance with the manufacturer's recommendations.

9. TECHNICAL SERVICES

Complete technical assistance is available.

10. FILING SYSTEMS

Electronic SPEC-DATA®
SPEC-DATA® II
Sweets Architectural Catalog
MASTERSPEC Section 07650

The ten-point Spec-Data® format has been reproduced from publications copyrighted by CSI, 1964, 1965, 1966, 1967, and used by permission of The Construction Specifications Institute, Alexandria, VA 22314.

**Table 1
Materials, Thickness and Weight**

Flashing Tape		Material			Thickness (mills.)		
Product Name	Product Code	Facing	Membrane Adhesive	Release Liner	Facer	Membrane Adhesive	Overall Total
Nashua OptiFlash F20	626-20	Alum. Foil	Butyl Rubber	Poly Coated Kraft Paper	2	17	19
Nashua OptiFlash B20	627-20	HDPE (Black)	Butyl Rubber	Poly Coated Kraft Paper	6	14	20
Nashua Contour	697-40	Cross Laminated HDPE (White)	Butyl Rubber	Poly Coated Kraft Paper	20	40	60
Polyken Foilastic	626-35	Alum. Foil	Butyl Rubber	LDPE (Blue)	2	33	35
Polyken Shadowlastic	627-35	HDPE (Black)	Butyl Rubber	LDPE (Blue)	6	29	35

Notes:

1. One mil thickness = 0.001 inches

**Table 2
Dimensions**

Flashing Tape	Roll Length (feet)	Tape Width (inches)
Nashua® Optiflash B20	100	4, 6, 9
Nashua® Optiflash B20	100	4, 6, 9
Polyken® Foilastic 626-35	50	2, 3, 4, 6, 9, 12
Polyken® Shadowlastic 627-35	50	6, 9, 12
Nashua® Contour 697-40	75	6, 8

Table 3: Physical Properties

Criteria		Flashing Tape				
Property	Test Method	Polyken®		Nashua®		
Product		Shadowlastic 627-35	Foilastic 626-35	OptiFlash B20 627-20	OptiFlash F20 626-20	Contour 697-40
Color (facer)		Black	Aluminum	Black	Aluminum	White
Thickness	ASTM D-3767 & ASTM D-1000	35 mils	35 mils	20 mils	20 mils	60 mils
Tensile Strength MD	ASTM D412-97	>*813 psi, 5602 kn/m ²	>*445 psi, 3066 kn/m ²	>*1371 psi, 9446 kn/m ²	>*800 psi, 5512 kn/m ²	>*295 psi, 2033 kn/m ²
Tensile Strength CD	ASTM D412-97	300 psi, 2411 kn/m ²	300 psi, 2411 kn/m ²	400 psi, 2756 kn/m ²	800 psi, 5512 kn/m ²	400 psi, 2756 kn/m ²
Elongation	ASTM D412-97	>180%	< 4%	>130%	<2.7%	>575%
Adhesion to Plywood	ASTM D903-93 ⁽¹⁾	141.3 oz/in 1.5 N/mm	196.4 oz/in 2.1 N/mm	62.7 oz/in 0.68 N/mm	96.0 oz/in 1.05 N/mm	96.4 oz/in 1.05 N/mm
Steel	PSTC-1	281.9 oz/in 3.1 N/mm	292.8 oz/in 3.2 N/mm	268.7 oz/in 2.9 N/mm	292.6 oz/in 3.2 N/mm	113.8 oz/in 1.2 N/mm
OSB	ASTM D903-93 ⁽¹⁾	125.3 oz/in 1.4 N/mm	139.3 oz/in 1.5 N/mm	64.2 oz/in 0.70 N/mm	76.5 oz/in 0.80 N/mm	100.6 oz/in 1.1 N/mm
Felt	ASTM D903-93 ⁽¹⁾	>9.4 lb/in 1.6 N/mm	176.6 oz/in 1.9 N/mm	68.4 oz/in 0.70N/mm	99.4 oz/in 1.1 N/mm	117.8 oz/in 1.3 N/mm
Housewrap	ASTM D903-93 ⁽¹⁾	221.9 oz/in 2.4 N/mm	243.8 oz/in 2.7 N/mm	210.2 oz/in 2.3 N/mm	232.1 oz/in 2.5 N/mm	>150.5 oz/in 1.6 N/mm
Unprimed Brick	ASTM D903-93 ⁽¹⁾	150.5 oz/in 1.6 N/mm	116.1 oz/in 1.3 N/mm	56.6 oz/in 0.60 N/mm	82.9 oz/in 0.90 N/mm	119.0 oz/in 1.3 N/mm
Extruded Vinyl	ASTM D903-93 ⁽¹⁾	237.0 oz/in 2.6 N/mm	238.8 oz/in 2.6 N/mm	162.2 oz/in 1.8 N/mm	201.0 oz/in 2.2 N/mm	139.8 oz/in 1.5 N/mm
Lap Adhesion (Adhesion to backing)	ASTM D903-93 ⁽¹⁾	200.0 oz/in 2.19 N/mm	200.0 Oz/in 2.19 N/mm	32.0 Oz/in 0.35 N/mm	16 oz/in 0.18 N/mm	
Pliability	ASTM D146-97 ⁽²⁾	No effect	No effect	No effect	No effect	No effect
Permeance	ASTM E96-94	<0.5 perm	<0.1 perm	<0.3 perm	<0.3 perm	
UV exposure resistance	AAMA 711-05	1 year	10 years	1 year	10 years	1 year
Installation Temp.	AAMA 711-05	20F-180F (1C-93C)	20F-180F (1C-93C)	20F-180F (1C-93C)	20F-180F (1C-93C)	20F-180F (1C-93C)
Service Temp.		-35F-200F (-37C - 93C)	-35F-200F (-37C - 93C)	-35F-200F (-37C - 93C)	-35F-200F (-37C - 93C)	-35F-200F (-37C - 93C)

Notes:

MD = Machine Direction

CD = Cross Direction

(1) ASTM D903-93 method was modified for a sample 24 hour adhesive contact period prior to testing

(2) ASTM D146-97 Pliability was determined after 24 hour conditioning at -40F and wrapping specimen around a 2" diameter mandrel

Table 4
Primers—Physical Properties

Criteria	Polyken® 1027	Nashua® 357
Base	Butyl based elastomers blended with polymeric resins	C-12 & C14 Isoalkanes polymers and resins
Solvent	V.M. and P Naptha	Hexane, Propane, Acetone & Dimethyl Ether
Total Solids	30% +/- 1%	15% +/- 1%
Weight	7.1 lbs/gal (0.86 kg/l)	23.8 oz/ 674 grams
Viscosity	Medium Syrup	not determined
Flash Point	40F (4C)	-104F/ -156C
Color	Black	White
Shelf Life	Excellent	One year
V.O.C.	4.9 lbs/gal (0.59 kg/l)	378 g/l
Application	Roller or Brush	Spray/Aerosol Can. Tape off area from overspray.
Coverage	4 sq. yds/gal (9.8m ² /l)	Varies

**Table 5
Sealant Adhesion**

		Location of Sealant (See Below)		
Type of Sealant	Adhesion	(1) Over Facing	(2) Along Seam	(3) Under Adhesive
Butyl	<51.0 oz/in	Yes	Yes	Yes
Hybrid	33.4 oz/in	Some	Some	Yes
Polyurethane	5.5 oz/in	Some	Some	Yes
Silicone	0.8 oz/in	No	Some	Yes

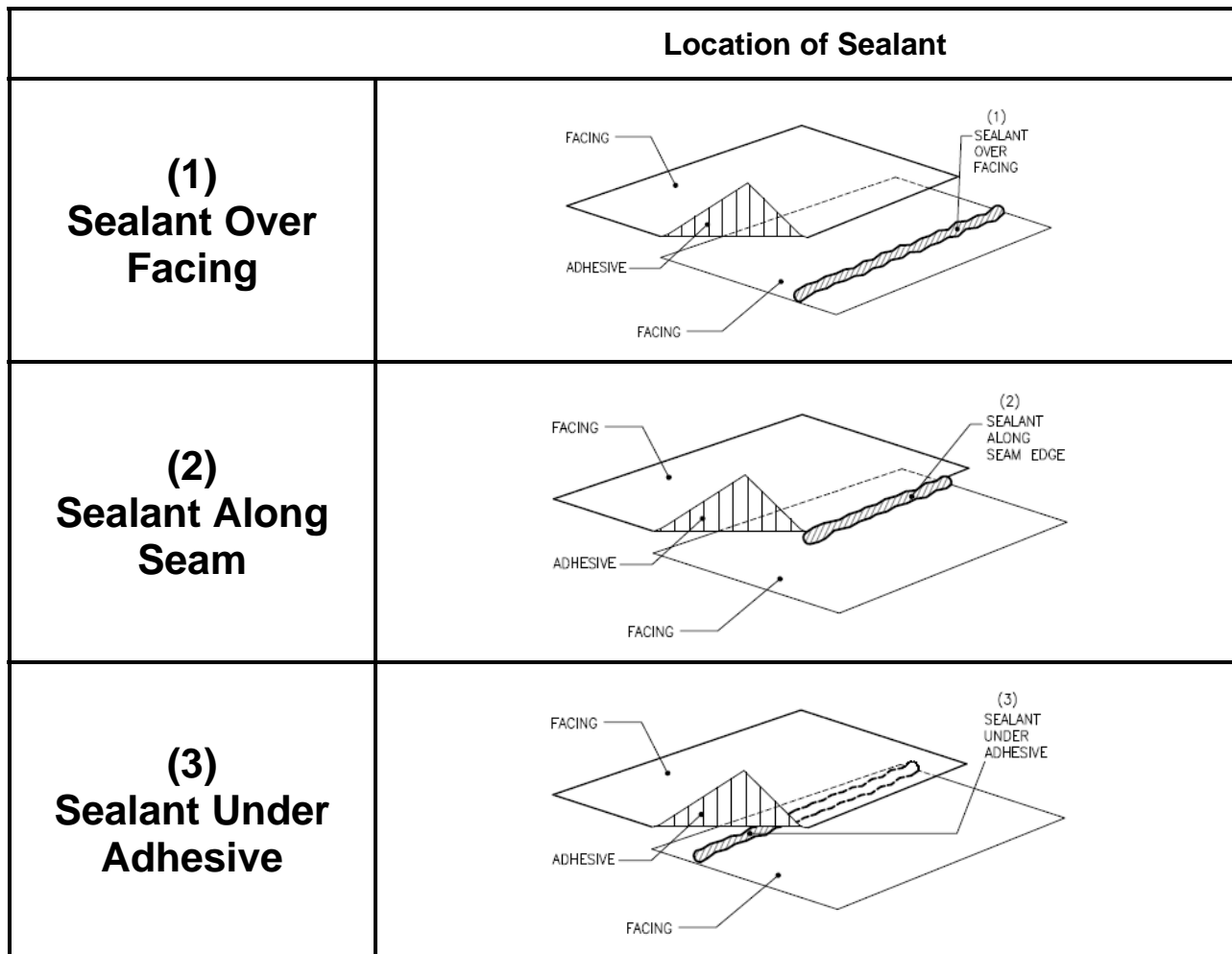

Table 6: Sealant Compatibility

Flashing Tape	Backing	Adhesive	side applied to	Sealant Name	Sealant Type	Visual Observation	Pass/ Fail	Exposure time @150F
n/a - control	LDPE film	none	backing	Dow Corning 795	Silicone	FI - unchanged, Sep	P	31
Sample A	2.5 mil PP	27.5 mil SBS A	backing	original color - white		FI, SLD, Sep	P	31
Sample A	2.5 mil PP	27.5 mil SBS A	adhesive			FI, MD, Sep, P, adh. Distorted	F	31
Sample B	14 mil PE	Butyl rubber	adhesive			FI, SLD, Sep	P	31
Sample C	14 mil PE	Butyl rubber	adhesive			FI, SLD, Sep	P	31
Sample D	6 mil PE	Butyl rubber	backing			FI, SLD, Sep	P	31
Sample D	6 mil PE	Butyl rubber	adhesive			FI, SLD, Sep	P	31
n/a - control	Si Rel. Paper	none	release	Vulkem 116	PU	FI, unchanged, Sep	P	31
Sample A	2.5 mil PP	27.5 mil SBS A	backing	original color - white		FI, SLD, Sep, P, adh. Flowed out	F	31
Sample A	2.5 mil PP	27.5 mil SBS A	adhesive			FI, HD, PB, HP, adh. Distorted	F	6
Sample B	14 mil PE	Butyl rubber	adhesive			FI, ND, PB	P	31
Sample C	14 mil PE	Butyl rubber	adhesive			FI, ND, PB	P	31
Sample D	6 mil PE	Butyl rubber	backing			FI, SD, Sep	P	31
Sample D	6 mil PE	Butyl rubber	adhesive			FI, SD, PB	P	31
n/a - control	Si Rel. Paper	none	release	Geocell 2300	TP Rubber	FI, unchanged, Sep	P	31
Sample A	2.5 mil PP	27.5 mil SBS A	backing	original color - clear, transparent		FI, MD, Sep	P	31
Sample A	2.5 mil PP	27.5 mil SBS A	adhesive			FI, MD, PB, MP, adh. Flowed	F	3
Sample B	14 mil PE	Butyl rubber	adhesive			FI, ND, PB	P	31
Sample C	14 mil PE	Butyl rubber	adhesive			FI, ND, PB	P	31
Sample D	6 mil PE	Butyl rubber	backing			FI, ND, Sep	P	31
Sample D	6 mil PE	Butyl rubber	adhesive			FI, ND, PB	P	31
n/a - control	Si Rel. Paper	none	release	Sikaflex 1a	PU	FI, unchanged, Sep	P	31
Sample A	2.5 mil PP	27.5 mil SBS A	backing	original color - white		FI, SD, Sep - falling off	F	31
Sample A	2.5 mil PP	27.5 mil SBS A	adhesive			FI, HD, PB, HP, adh. Distorted	F	3
Sample B	14 mil PE	Butyl rubber	adhesive			FI, ND, PB	P	31
Sample C	14 mil PE	Butyl rubber	adhesive			FI, SD, PB	P	31
Sample D	6 mil PE	Butyl rubber	backing			FI, SD, Sep	P	31
Sample D	6 mil PE	Butyl rubber	adhesive			FI, SD, PB	P	31
n/a - control	Si Rel. Paper	none	release	Geocell 3300	PU	FI, unchanged, Sep	P	31
Sample A	2.5 mil PP	27.5 mil SBS A	backing	original color - rust		FI, ND, Sep, HP, adh. Flowed out	F	31
Sample A	2.5 mil PP	27.5 mil SBS A	adhesive			FI, ND, fell off, HP, very distorted	F	3
Sample B	14 mil PE	Butyl rubber	adhesive			FI, ND, PB	P	31
Sample C	14 mil PE	Butyl rubber	adhesive			FI, ND, PB	P	31
Sample D	6 mil PE	Butyl rubber	backing			FI, ND, Sep	P	31
Sample D	6 mil PE	Butyl rubber	adhesive			FI, ND, PB	P	31

Note- None of the sealants tested reacted with the butyl rubber adhesive formulations. All of the sealants tested reacted with the SBS asphalt adhesive system that was tested.

Key:

LB - light surface bloom on backing
 MB - moderate surface bloom on backing
 HB - heavy surface bloom on backing
 N - no
 SL - slight
 M - moderate

Sep - can separate
 PB - permanently bonded
 H - heavy
 D - discoloration
 P - plasticized
 Br - brittle
 FI - flexible

Nashua®
TAPE PRODUCTS

626-20



NASHUA® 626-20
Optiflash F20 Window Flashing Tape

APPLICATIONS

- Window and Door Installations
- Corner Board Abutments
- Sidewall sheathing seams.
- Deck-to-wall Joints
- Sealing other detail areas against water and air penetration

FEATURES & BENEFITS

- Consists of a butyl-based adhesive which exhibits excellent adhesion to most building materials including plywood, OSB, housewrap, concrete, and most metals
- Provides long-term weather-tight seal to prevent moisture, vapor, and air penetration.
- Kraft paper release liner for ease of application.
- Resists UV degradation for 12+ years of direct sun exposure.
- Flexible at low temperatures; stays pliable to maintain a tight seal.
- Provides strong and immediate adhesion over a wide range of application temps (20°F-180°F)
- Compatible with sealants and caulking. Does not react with solvent-based solutions.
- Available in 4", 6" and 9"

CONSTRUCTION

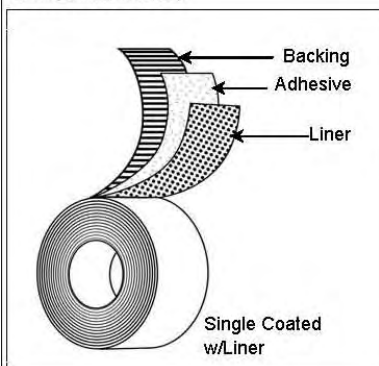

PRODUCT DESCRIPTION

Single-Coated w/Liner Construction

Backing:

- 2 mil Aluminum Foil

Adhesive:

- Butyl Rubber

Liner:

- Release-coated Kraft Paper

Colors:

- Aluminum

TEST DATA

Test	Typical Value	Typical Value (Metric)	Test Method
Total Thickness	20 mils	508.00 μ	ASTM D 1000
Backing Thickness	2 mils	50.80 μ	ASTM D 1000
Adhesive Thickness	18 mils	457.20 μ	ASTM D 1000
Adhesion Values			
Steel	18.3 lb./in.	3.20 N/mm	PSTC-1
Plywood	>6 lb./in.	1.05 N/mm	ASTM D903-9:
OSB	>4.8 lb./in.	0.8 N/mm	
Felt	>6.2 lb./in.	1.1 N/mm	
Unprimed Brick	>5.2 lb./in.	0.9 N/mm	
Housewrap	>14.5 lb./in.	2.5 N/mm	
Extruded Vinyl	>12.6 lb./in.	2.2 N/mm	
Tensile Strength (Machine)	800 psi	5512 kN/m2	ASTM D412-9
Tensile Strength (Cross)	800 psi	5512 kN/m2	ASTM D412-9
Application Temperature Range	20°F to 180°F	-7°C to 82°C	
Service Temperature Range	-35°F to 200°F	-37°C to 93°C	

* Rectangular specimen

** Test after 24 hour dwell time at 73°F and 50% humidity to p

The information presented herein was prepared at Berry Plastics, Tapes & Coatings Division (25 Forge Parkway Franklin, MA 02038) by qualified technical person. To Berry's knowledge it is true and accurate. However, the information and recommendations are furnished for these products with the understanding that the purchaser or user, as the case may be, will independently determine that the product is suitable for the intended use, and that such use complies with all applicable federal, state and local laws and regulations. The data are submitted only for the user's information and consideration, and do not constitute a warranty of any kind (including but not limited to a warranty of merchantability or of fitness for a particular purpose), or a representation for which BERRY PLASTICS assumes any legal responsibility.

POLYKEN® 626-35



POLYKEN® 626-35
Foilastic Premium Flashing Tape

APPLICATIONS

- Used to flash hip, ridge, and penetration details on concrete tile roofs.
- Gutters, roof valleys and eaves, chimneys and vents, rooftop duct systems.
- Sheet metal repairs on mobile homes, outdoor buildings, and trailers.
- Flash around window, door, skylight and dormer openings.
- Any above-grade critical areas that need protection against water and air leaks.

FEATURES & BENEFITS

- Provides an excellent bond to wood, metal, vinyl and other common building materials.
- Compatible with most caulking and sealants - does not react with most solvent-based solutions.
- Provides long-term weather-tight seal to prevent air, moisture, and water vapor penetration.
- Easy to remove blue LDPE release liner that will not tear.
- Paintable aluminum backing.
- Flexible at low temperatures & stays pliable to maintain a tight seal.
- No cracking over 1/4" at mandrel at 0°F.
- Protective aluminum backing allows for indefinite UV exposure.
- This product is covered by 12-year limited warranty. Please see warranty for details.

CONSTRUCTION

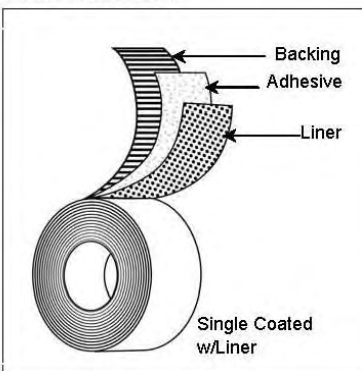

PRODUCT DESCRIPTION

Single-Coated w/Liner Construction

Backing:

- 2 mil Aluminum Foil

Adhesive:

- Butyl Rubber

Liner:

- Blue LDPE

Colors:

- Aluminum

TEST DATA

Test	Typical Value	Typical Value (Metric)	Test Method
Total Thickness	35 mils	889.00 μ	ASTM D 1000
Backing Thickness	2 mils	50.80 μ	ASTM D 1000
Mastic Thickness	33 mils	838.20 μ	ASTM D 1000
Adhesion Values			
Steel	18.3 lb./in.	3.20 N/mm	PSTC-1
Plywood	>12.3 lb./in.	2.1 N/mm	ASTM D903-93
OSB	>8.7 lb./in.	1.5 N/mm	
Felt	>11 lb./in.	1.9 N/mm	
Unprimed Brick	>7.3 lb./in.	1.3 N/mm	
Housewrap	>15.2 lb./in.	2.7 N/mm	
Extruded Vinyl	>14.9 lb./in.	2.6 N/mm	
Tensile Strength (Machine)	445 psi	3066 kN/m2	ASTM D412-97
Tensile Strength (Cross)	300 psi	2411 kN/m2	ASTM D412-97
Application Temperature Range	20°F to 180°F	-7°C to 82°C	
Service Temperature Range	-30°F to 200°F	-34°C to 93°C	

***Recommended storage conditions: 40-60% Humidity, 60°F-80°F (15°C - 20°C)

The information presented herein was prepared at Berry Plastics, Tapes & Coatings Division (25 Forge Parkway Franklin, MA 02038) by qualified technical personnel. Berry's knowledge is true and accurate. However, the information and recommendations are furnished for these products with the understanding that the purchaser in the case may be, will independently determine that the product is suitable for the intended use, and that such use complies with all applicable federal, state and local regulations. The data are submitted only for the user's information and consideration, and do not constitute a warranty of any kind (including but not limited to a warrant merchantability or of fitness for a particular purpose), or a representation for which BERRY PLASTICS assumes any legal responsibility.



627-20



NASHUA® 627-20
Optiflash B20 Window Flashing Tape

APPLICATIONS

- Window and Door Installations
- Corner Board Abutments
- Sidewall sheathing seams
- Deck-to-wall Joints
- Sealing other detail areas against water and air penetration

FEATURES & BENEFITS

- Consists of a butyl-based adhesive which exhibits excellent adhesion to most building materials including plywood, OSB, housewrap, concrete, and most metals.
- Provides long-term weather-tight seal to prevent moisture, vapor, and air penetration.
- Kraft paper release liner for ease of application.
- Resists UV degradation for up to 1 year of direct sun exposure.
- Flexible at low temperatures; stays pliable to maintain a tight seal.
- Provides strong and immediate adhesion over a wide range of application temps (20°F-180°F).
- Compatible with sealants and caulking. Does not react with solvent-based solutions.
- Available in 4", 6" and 9"

CONSTRUCTION

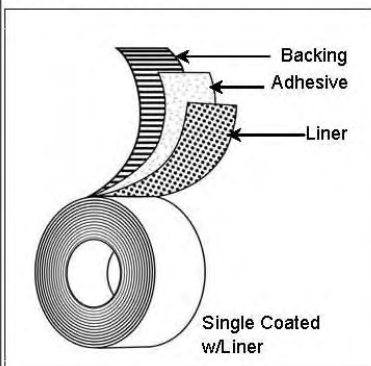

PRODUCT DESCRIPTION

Single-Coated w/Liner Construction

Backing:

- Polyethylene

Adhesive:

- Butyl Rubber

Liner:

- Release-coated Kraft Paper

Colors:

- Black

TEST DATA

Test	Typical Value	Typical Value (Metric)	Test Method
Total Thickness	20 mils	508.00 μ	ASTM D 1000
Backing Thickness	6 mils	152.40 μ	ASTM D 1000
Adhesive Thickness	14 mils	355.60 μ	ASTM D 1000
Adhesion Values			
Steel	16.8 lb./in.	2.90 N/mm	PSTC-1
Plywood	>3.91 lb./in.	0.68 N/mm	ASTM D903-9.
OSB	>4.0 lb./in.	0.7 N/mm	
Felt	>4.3 lb./in.	0.7 N/mm	
Unprimed Brick	>3.5 lb./in.	0.6 N/mm	
Housewrap	>13.1 lb./in.	2.3 N/mm	
Extruded Vinyl	>10.1 lb./in.	1.8 N/mm	
Tensile Strength (Machine)	1371 psi	9446 kN/m2	ASTM D412-9
Tensile Strength (Cross)	400 psi	2756 kN/m2	ASTM D412-9
Application Temperature Range	20°F to 180°F	-7°C to 82°C	
Service Temperature Range	-35°F to 200°F	-37°C to 93°C	

* Rectangular specimen

Recommended storage conditions: 40-60% Humidity, 60°F-80°F

The information presented herein was prepared at Berry Plastics, Tapes & Coatings Division (25 Forge Parkway Franklin, MA 02038) by qualified technical person. To Berry's knowledge it is true and accurate. However, the information and recommendations are furnished for these products with the understanding that the user or user, as the case may be, will independently determine that the product is suitable for the intended use, and that such use complies with all applicable federal, state and local laws and regulations. The data are submitted only for the user's information and consideration, and do not constitute a warranty of any kind (including but not limited to a warranty of merchantability or of fitness for a particular purpose), or a representation for which BERRY PLASTICS assumes any legal responsibility.



25 Forge Parkway
Franklin, MA 02038
800-343-7875
www.berryplastics.com



POLYKEN® 627-35



POLYKEN® 627-35
Shadowlastic Premium Flashing Tape

APPLICATIONS

- Used under tile on the ridge and hip lines of roofs to prevent moisture from entering the building.
- Flash around window and door openings.
- Flash around skylights and dormers.
- Any above-grade critical areas that need protection against air and moisture penetration.

FEATURES & BENEFITS

- Provides an excellent bond to wood, metal, vinyl and other common building materials.
- Formulated for conformability in both warm and cold weather temperatures.
- Compatible with most caulking and sealants - does not react with most solvent-based solutions.
- Provides a long-term weather-tight seal to prevent air, moisture and water vapor penetration.
- Resists UV degradation for up to 1 year of direct exposure to sunlight.
- Easy to remove blue LDPE release liner that will not tear.
- This product is covered by 12-year limited limited warranty. Please see warranty for details.

CONSTRUCTION

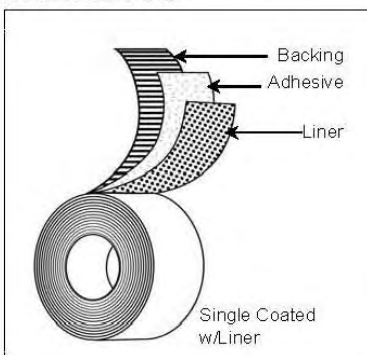

PRODUCT DESCRIPTION

Single-Coated w/Liner Construction

- Backing:**
- Polyethylene
- Adhesive:**
- Butyl Rubber
- Liner:**
- Blue LDPE
- Colors:**
- Black

TEST DATA

Test	Typical Value	Typical Value (Metric)	Test Method
Total Thickness	35 mils	889.00 µ	ASTM D 1000
Backing Thickness	6 mils	152.40 µ	ASTM D 1000
Mastic Thickness	29 mils	736.60 µ	ASTM D 1000
Adhesion Values			
Steel	17.6 lb./in.	3.10 N/mm	PSTC-1
Plywood	>8.8 lb./in.	1.5 N/mm	ASTM D903-93
OSB	>7.8 lb./in.	1.4 N/mm	
Felt	>9.4 lb./in.	1.6 N/mm	
Unprimed Brick	>9.4 lb./in.	1.6 N/mm	
Housewrap	>13.9 lb./in.	2.4 N/mm	
Extruded Vinyl	>14.8 lb./in.	2.6 N/mm	
Tensile Strength (Machine)	813 psi	5602 kN/m ²	ASTM D412-97
Tensile Strength (Cross)	300 psi	2411 kN/m ²	ASTM D412-97
Application Temperature Range	20°F to 180°F	-7°C to 82°C	
Service Temperature Range	-30°F to 200°F	-34°C to 93°C	

**Recommended storage conditions: 40-60% Humidity, 60°F-80°F

The information presented here in was prepared at Berry Plastics, Tapes & Coatings Division (25 Forge Parkway, Franklin, MA 02038) by qualified technical personnel. To Berry's knowledge it is true and accurate. However, the information and recommendations are furnished for these products with the understanding that the purchaser or user, as the case may be, will independently determine that the product is suitable for the intended use, and that such use complies with all applicable federal, state and local laws and regulations. The data are submitted only for the user's information and consideration, and do not constitute a warranty of any kind (including but not limited to a warranty of merchantability or of fitness for a particular purpose), or a representation for which BERRY PLASTICS assumes any legal responsibility.

Nashua®
TAPE PRODUCTS

Contour



NASHUA® Contour
Stretchable Window Flashing Tape

APPLICATIONS

- Excellent for flashing around window sills, interior corners of recessed windows, round top windows, and arched doorways
- Eliminates the need for corner flashing patches at window sides
- Any above-grade critical areas that need protection against air and moisture penetration

FEATURES & BENEFITS

- Consists of a butyl-based adhesive which exhibits excellent adhesion to most building materials including plywood, OSB, housewrap, concrete and most metals.
- Wide application temperature range (20° to 180°F).
- Provides a long-term weather-tight seal to prevent air, moisture, and vapor penetration.
- UV inhibitors prevent degradation for up to 1 year of direct exposure to the sun.
- Exceptional moisture resistance.
- Conforms easily to curved surfaces - forms a permanent watertight/airtight seal.
- An all-weather flashing tape - remains flexible and adheres in cold temperatures
- Available in 6" & 8" widths.

CONSTRUCTION

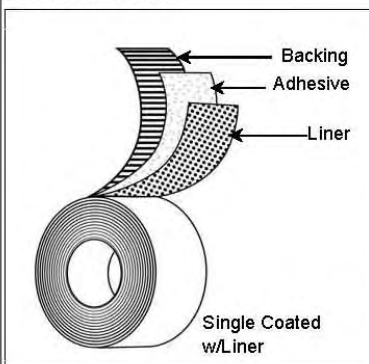

PRODUCT DESCRIPTION

Single-Coated w/Liner Construction

- Backing:**
- Creped, cross-laminated Polyolefin Film
- Adhesive:**
- Butyl Rubber
- Liner:**
- Polyethylene
- Colors:**
- White

TEST DATA

Test	Typical Value	Typical Value (Metric)	Test Method
Total Thickness	60 mils	1524.00 µ	ASTM D 1000
Adhesion Values			
Steel	>7.1 lb./in.	1.20 N/mm	PSTC-1
Plywood	>6 lb./in.	1.05 N/mm	ASTM D903-9:
OSB	>6.3 lb./in.	1.1 N/mm	
Felt	>7.4 lb./in.	1.3 N/mm	
Unprimed Brick	>7.4 lb./in.	1.3 N/mm	
Housewrap	>9.4 lb./in.	1.6 N/mm	
Extruded Vinyl	>8.7 lb./in.	1.5 N/mm	
Tensile Strength (Machine)	>295 psi	2033 kN/m2	ASTM D412-9*
Tensile Strength (Cross)	>400 psi	2756 kN/m2	ASTM D412-9*
Application Temperature Range	20°F to 180°F	-7°C to 82°C	
Service Temperature Range	-30°F to 200°F	-34°C to 93°C	

* Rectangular specimen

** Test after 24 hour dwell time at 73°F and 50% humidity to plywood

Recommended storage conditions: 40-60% Humidity, 60°F-80°F

The information presented herein was prepared at Berry Plastics, Tapes & Coatings Division (25 Forge Parkway Franklin, MA 02038) by qualified technical personnel. To Berry's knowledge it is true and accurate. However, the information and recommendations are furnished for these products with the understanding that the purchaser or user, as the case may be, will independently determine that the product is suitable for the intended use, and that such use complies with all applicable federal, state and local laws and regulations. The data are submitted only for the user's information and consideration, and do not constitute a warranty of any kind (including but not limited to a warranty of merchantability or of fitness for a particular purpose), or a representation for which BERRY PLASTICS assumes any legal responsibility.

POLYKEN®**1027**

POLYKEN® 1027
Primer/Liquid Adhesive System

APPLICATIONS

- Surface preparation for masonry, concrete, OSB, rigid insulation, wood and metal.
- Brush or roller priming applications.
- Provides a uniformly smooth, instant-tack surface to promote adhesion and long term anchorage.

FEATURES & BENEFITS

- Non-toxic, non-polluting.
- Conforms to local and national standards.
- Dries to a uniform, smooth finish to provide a superior bonding surface for butyl-based flashing tapes.
- Easy to apply, no over-spray.

Product Basics

Polyken® liquid adhesive systems are recommended for use with Polyker® and Nashua® window, door, and roof flashing products. The liquid adhesive system consists of butyl based elastomers blended with polymeric resins dissolved in an organic solvent system. They can be used for hand, brush, or roller application are non-toxic, non-polluting, and conform to local and national standards

Base:	Rubber/Resins
Solvent:	V.M. & P Naptha
Total Solids:	30%
Weight/Gallon:	7.1 lb
Weight/Liter:	.86 kg

Physical Characteristics

Property	Value
Viscosity	Medium Syrup
Flash Point	+40°F (4°C)
Color	Black
Shelf Life	Excellent
VOC	4.9 lbs/gal (0.59 kg/l)
Coverage Rate	4 Sq/Gal (9.8 m ² /l)

Warning: Polyken® liquid adhesive systems are FLAMMABLE MIXTURES.

Caution: Store away from heat source. Read all label instructions prior to use.

***Recommended storage conditions: 40-60% Humidity, 60°F-80°F (15°C - 20°C)

The information presented herein was prepared at Berry Plastics, Tapes & Coatings Division (25 Forge Parkway Franklin, MA 02038) by qualified technical personnel. Berry's knowledge is true and accurate. However, the information and recommendations are furnished for these products with the understanding that the purchaser or the user shall independently determine that the product is suitable for the intended use, and that such use complies with all applicable federal, state and local regulations. The data are submitted only for the user's information and consideration, and do not constitute a warranty of any kind (including but not limited to a warranty of merchantability or of fitness for a particular purpose), or a representation for which BERRY PLASTICS assumes any legal responsibility.

General Flashing Application Guide

Polyken® and Nashua® Flashing Tapes

Cutting Polyken® and Nashua®

Polyken® and Nashua® are flexible, self-adhering membrane flashing materials which can be used for general overall flashing conditions requiring broad coverage. Polyken® and Nashua® can also be easily cut to fit precise and detailed shapes.

A sharp cutting tool, such as a utility knife provides a simple and convenient method of cutting Polyken® and Nashua® flashing tape to desired lengths and shapes. Position the Polyken® or Nashua® tape on a solid uniform cutting surface, such as plywood, to control the material during the cutting procedure.

Lay a straight edge over the Polyken® or Nashua® material to guide the cutting tool to ensure straight cuts. See Figure 1.

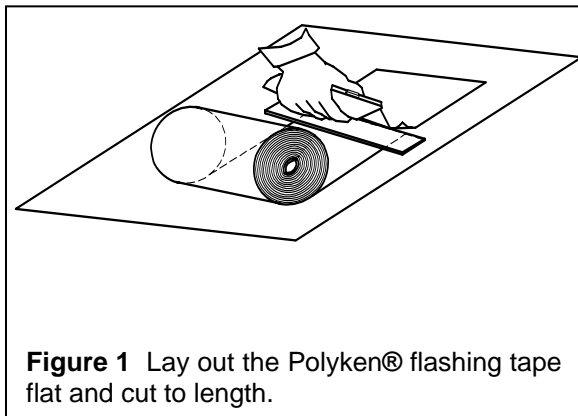

Figure 1 Lay out the Polyken® flashing tape flat and cut to length.

Removing Polyken® and Nashua® Release Liner

The Polyken® or Nashua® release liner is intended to stay on the membrane until the

membrane is ready for final placement and adhesion to its substrate. The release liner can generally be removed from the Polyken® or Nashua® by peeling back the edge of the liner with fingertips to separate the liner from the membrane.

The liner can be easily removed from the membrane by pulling the liner apart with a continuous motion. See Figure 2.

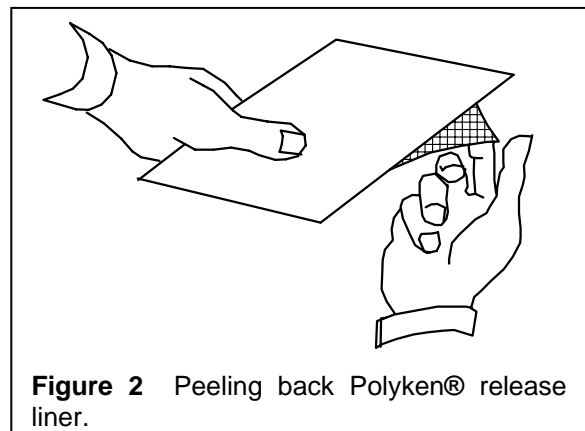

Figure 2 Peeling back Polyken® release liner.

Another technique can be used if it is difficult to get a thumbnail under the liner. Pinch the liner edge with the thumbnail tight to the membrane. While pinching, pull the edge sharply to attempt to pick off a tiny edge piece. Typically, this will cause the liner to stretch and when the pressure is released the liner edge will be wrinkled enough to allow it to be peeled back from the membrane.

Another technique, requiring some skill, is to carefully dig the point of the cutting tool into the release liner and peel back the edge.

Properly dispose of the peeled away Polyken® or Nashua® release liner.

Curved Cuts

Wide curved cuts can be made by using the same technique as straight cuts or by using firm, steady hand control to guide cut lines.

Tight curves and circles can be made by using heavy-duty shears or by carefully using a utility knife. Regularly shaped circles can be made by using a template.

To make Polyken® and Nashua® circles approximately three inches in diameter for patches and circle boots, use the following technique. Spread out a portion of Polyken® or Nashua® tape. Place an empty Polyken® or Nashua® core tube on top of the membrane. (The diameter of the tube is about 3-1/4 inches.) Use a cutting tool, such as a utility knife, to cut around the outside of the tube through the Polyken® tape. The cuts may have to be done one-third of the circumference at a time in order to complete the circle.

See Figures 3 & 4. Remove cut Polyken® or Nashua® circles and save for future use.

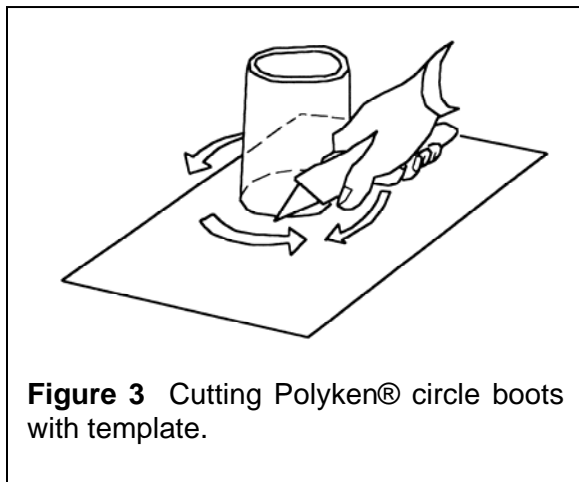

Figure 3 Cutting Polyken® circle boots with template.

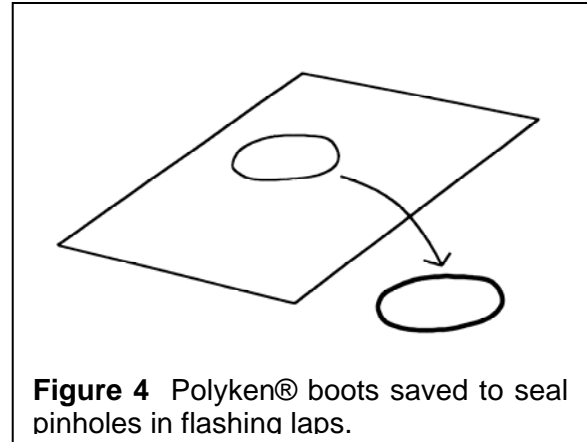

Figure 4 Polyken® boots saved to seal pinholes in flashing laps.

Cutting the Release Liner

Cutting the Polyken® or Nashua® release liner and peeling away a portion of the release liner is sometimes necessary in order to adhere a portion of the Polyken® or Nashua® membrane a section at a time. In the case of cutting the release liner, take extreme care not to cut too deeply into the membrane.

Step 1. Cut only deep enough to cut through the release liner. You may want to practice this technique several times on scrap Polyken® or Nashua® pieces before attempting to complete a final cut. See Figure 5.

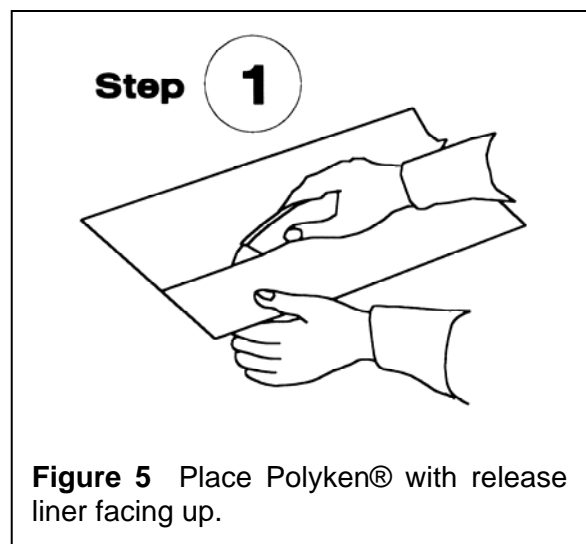
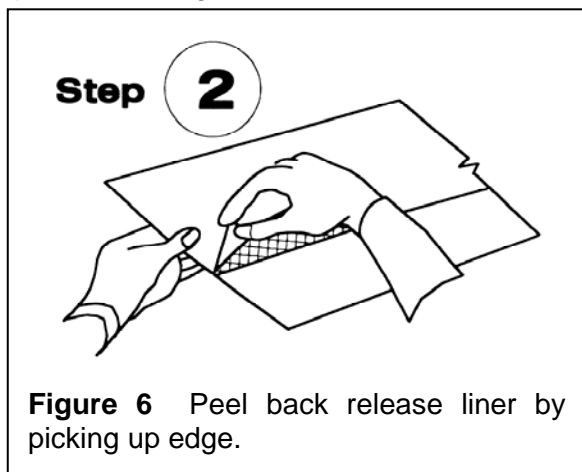
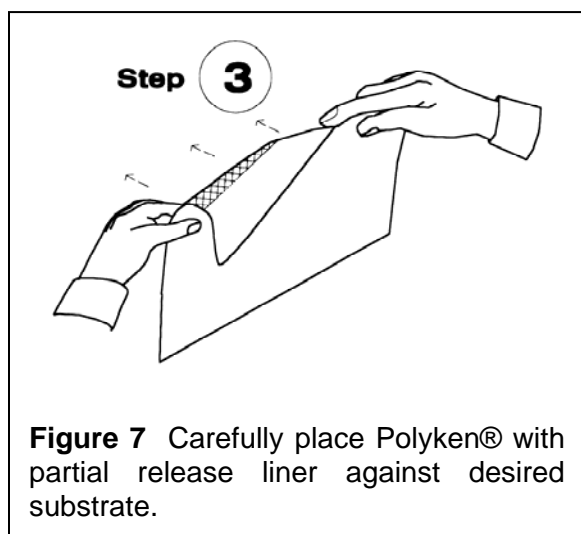

Figure 5 Place Polyken® with release liner facing up.

Step 2. Pick a corner of the release liner and peel back a portion of the liner leaving the desired portion of the release liner in place. See Figure 6.



Step 3. Place the Polyken® or Nashua® tape with the partial release liner against the substrate. See Figure 7.



Polyken® and Nashua® Placement

Use sections of Polyken® or Nashua® as long and as wide as practical to complete the work. Minimize the number of seams and laps where long sections of material are

to be applied. Carefully preplan the location of seams, laps and termination edges.

If possible, install Polyken® or Nashua® in “shingle fashion,” so that edges are lapped to prevent gravity-induced water flow from entering the joints between layers or behind the flashing. The layout of laps, seams and edges of Polyken® flashing should be considered prior to placement. Polyken® and Nashua® however, have excellent adhesion to itself, so patches can be effectively made by over laying Polyken® on top of Polyken®.

Large lengths of Polyken® or Nashua® can be unwieldy. When installing large sections, partial removal of the release liner and subsequent partial adhesion of the membrane will facilitate placement at the desired location.

Precise placement of Polyken® or Nashua® membrane at terminations and other detailed configurations should be carefully planned to determine the most effective sizes of Polyken® to use.

Using a Roller to Increase Adhesion

Polyken® or Nashua® readily adheres to most construction substrates by removing the release liner and placing Polyken® or Nashua® in the desired position by hand.

Rolling the Polyken® or Nashua® facing with a hand roller after placement increases the effective adhesion to most substrates. Roll the membrane from the center toward the edges, pushing out trapped pockets of air and flattening wrinkles. Eliminating air pockets and wrinkles, especially along flashing edges, greatly increases the integrity of the flashing adhesion. Rolling is required to provide continuous adhesion at flashing laps and seams. See Figure 8.

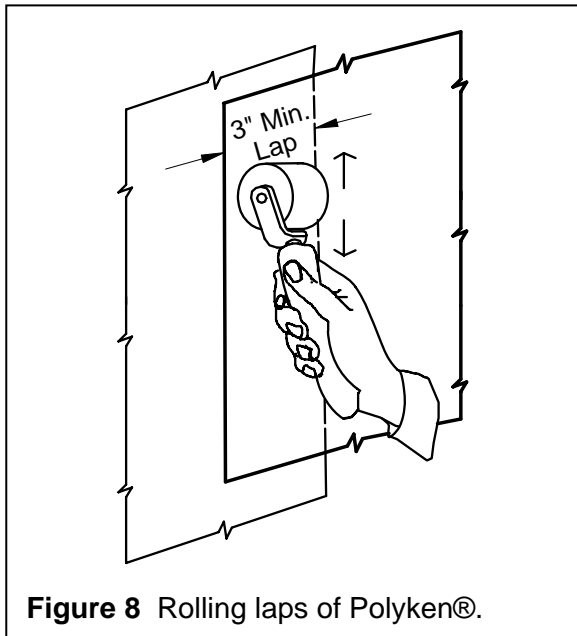

Figure 8 Rolling laps of Polyken®.

Rollers

Hand rollers used for rolling Polyken® or Nashua® flashing tapes can be found from many construction industry sources. Rollers used in the flooring and wallpapering trades are effective tools for Polyken® and Nashua® applications. See Figure 9.

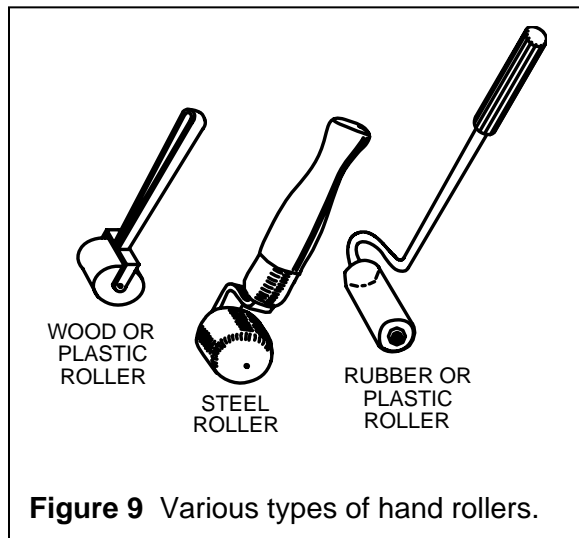

Figure 9 Various types of hand rollers.

We recommend obtaining rollers in several sizes and types to be able to fit the various edges associated with inside and outside corners and overlaps. Rollers in 1" and 2" sizes with short handles are particularly useful in tight spaces, but at least one 3" roller is suggested to enable smooth rolling of the recommended 3" overlap and large areas of Polyken® or Nashua® tape.

Care should be taken with hand roller edges not to cut through the Polyken® or Nashua® facing or adhesive layer.

Avoid rolling against sharp outside corners. Outside corners should be rolled parallel to the direction of the corner with the roller flat to each alternate side of the corner.

Roll inside corners taking care to avoid having the roller tear the Polyken® or Nashua® membrane or facing. This can be accomplished using one of the following alternate techniques:

1. Roll inside corners perpendicular to the corner with a back-and-forth motion gradually moving the roller up and down the length of the corner. See Figure 10.

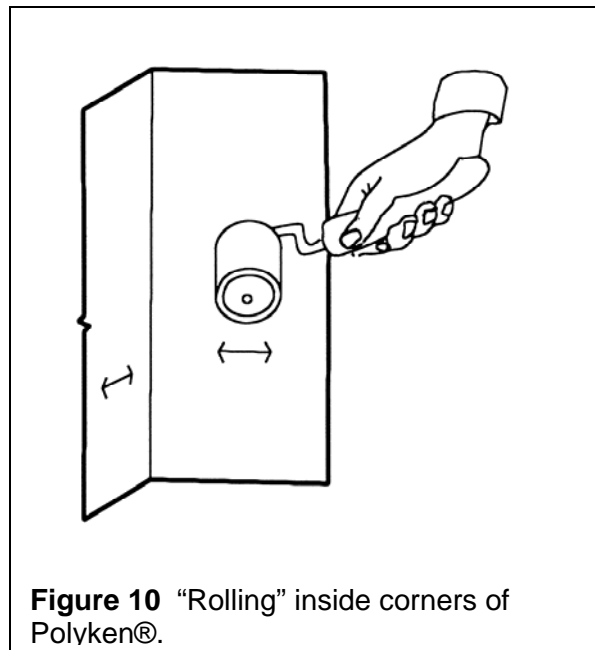

Figure 10 "Rolling" inside corners of Polyken®.

2. Roll parallel to the inside corner keeping carefully back from the corner juncture.
3. Use a roller with a radius edge that can be used up and down the length of the corner juncture without tearing the membrane or facing. The roller radius edge should be greater than the membrane radius at the corner juncture.

Polyken® or Nashua® Coverage

Wide Rolls and Extended Lengths

Large sections of Polyken® or Nashua® membrane should be used where practical to minimize the number of laps and seams in the flashing installation.

Laps and Seams

Polyken® or Nashua® can be overlaid as a flashing membrane on top of a flashing membrane to provide an effective waterproofing barrier. Recommended lap coverage is three inches minimum.

This lap dimension should be rolled for best adhesion. Greater lap dimensions can help assure more material-to-material adhesion providing additional protection against potential field installation errors.

Small Patches

Short pieces of Polyken® or Nashua® can be applied over Polyken® or Nashua® membrane to successfully maintain an effective waterproof barrier. Patches can be used to repair any mechanical damage to the membrane that occurs after installation.

Patches may also be used to repair tears, splits and cuts. Generally, the patches used for repair should extend beyond the damage in all directions by 1-1/2 inches minimum. The patch needs to be sufficiently larger

than the damaged area to completely cover it and adhere to surrounding membrane or substrate to complete the membrane integrity. Repair patches should be rolled for best adhesion.

Bends and Shapes

Polyken® and Nashua® have excellent pliability characteristics. Tight radii are easily formed with Polyken® or Nashua®. It is well suited to conform to the inside and outside corners of most building substrates. It is also a material that can be made into shapes to fit unique and difficult flashing conditions. Polyken® or Nashua® serves as a durable barrier for smooth curves, bends and folds.

Folds

Polyken® or Nashua® is an excellent material that folds when necessary to complete uniform waterproofing applications, such as, one-piece corner boots.

Folds should be done by hand, and rolling should not occur with too much roller pressure against the fold edge or the facing material may tear.

Polyken® and Nashua® Circle Boots

Special application conditions can be addressed with Polyken® or Nashua® circle boots. These special boots or patches cut into circular shapes from Polyken® flashing tape can be used at multidirectional junctures.

Polyken® or Nashua® circle boots can cover pinhole conditions remaining from the application of other flashing material laps at complex substrate conditions.

Polyken® or Nashua® circle boots conform to fit the shape of multiple planes of substrates, such as inside and outside corners. Preplan the placement by checking the fit and pre-shaping the folds to fit the configuration.

Applying Polyken® or Nashua® Circle Boots

Step 1. Using one of the release liner removal techniques, peel back the liner. See Figure 11.

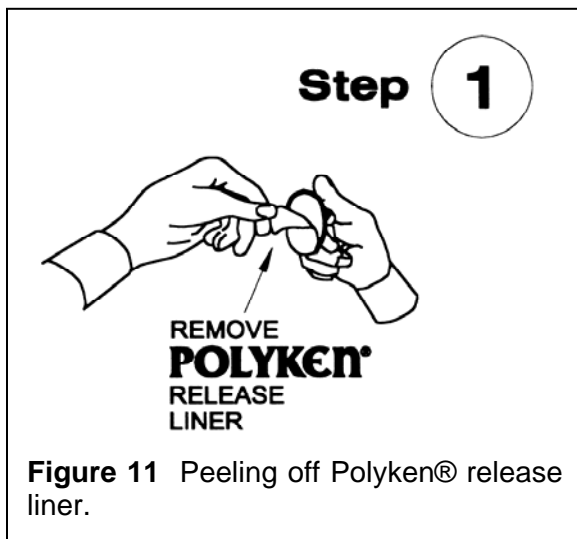

Figure 11 Peeling off Polyken® release liner.

Step 2. Carefully fit the Polyken® or Nashua® circle boot in place. See Fig. 12.

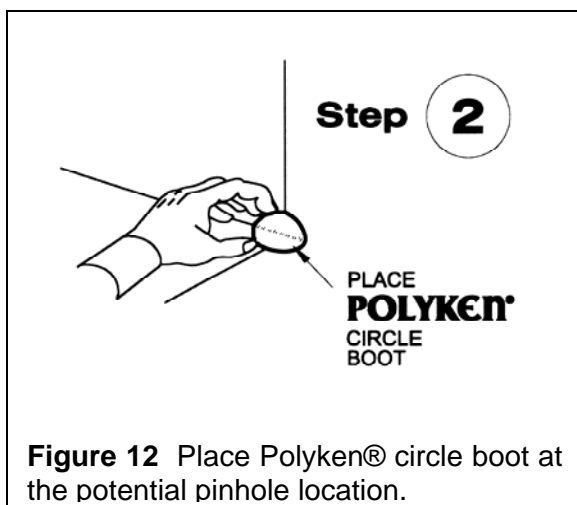

Figure 12 Place Polyken® circle boot at the potential pinhole location.

Step 3. Form the Polyken® or Nashua® circle boot to the substrate using finger pressure. See Figure 13.

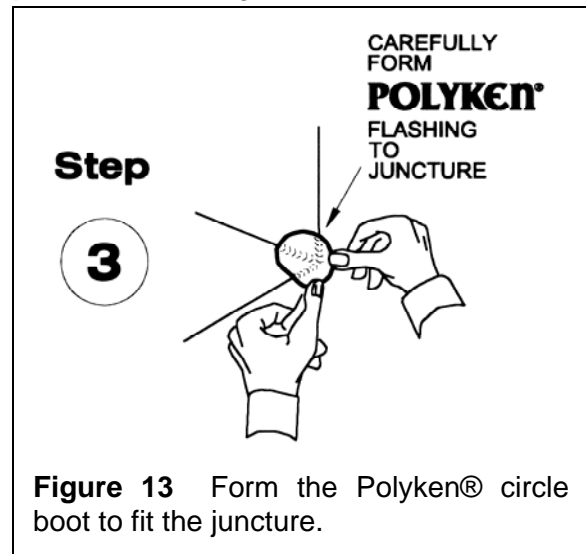

Figure 13 Form the Polyken® circle boot to fit the juncture.

Inside Corner Flashing

Inside corners in construction occur with recessed windows and building ledges or shelves. See Figure 14. These junctures require complex flashing layout when using multiple sheets of flashing. To make inside corner flashings, use precut and preformed pieces of Polyken® or Nashua® flashing tape. The following procedures illustrate the method for making an inside corner flashing.

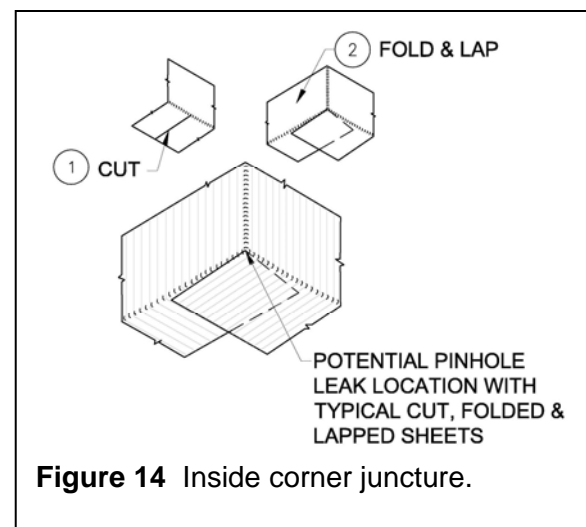

Figure 14 Inside corner juncture.

Steps 1 - 3. Precut a square (6" minimum) of Polyken® or Nashua® and fold in halves twice. See Figures 15 & 16.

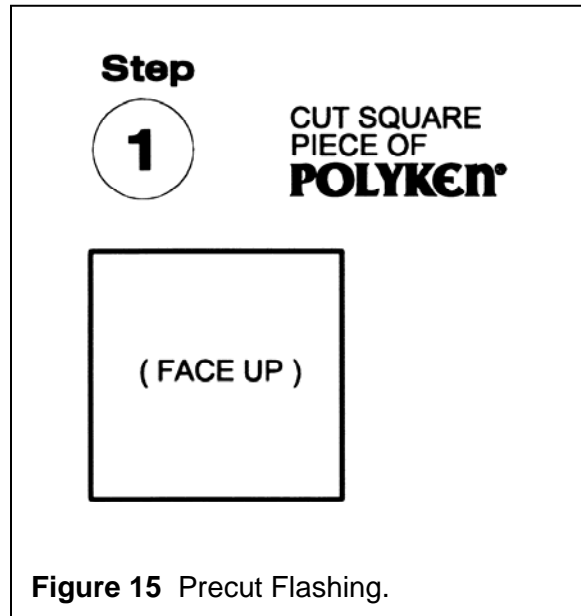

Figure 15 Precut Flashing.

Step 4. Unfold the Polyken® or Nashua® flashing tape and select a corner to crease to the middle of the square. See Figure 17.

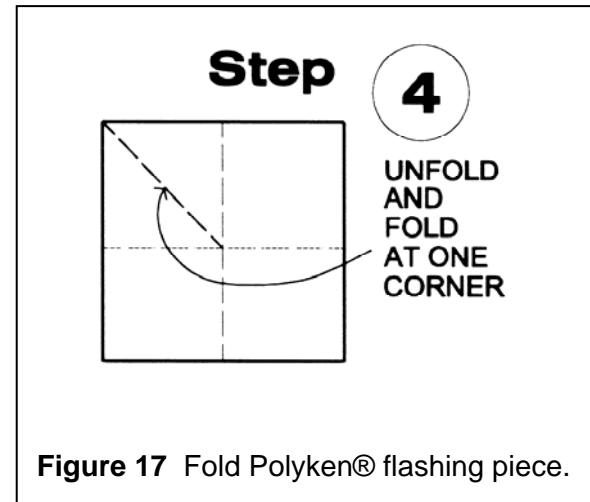

Figure 17 Fold Polyken® flashing piece.

Step 5. Pinch the crease to make a triangle shape and fold the square in a shape of an inside corner. See Figure 18.

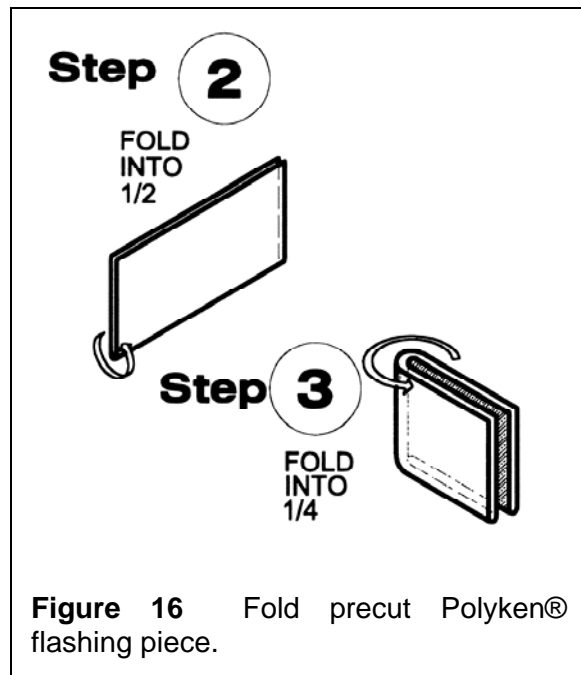

Figure 16 Fold precut Polyken® flashing piece.

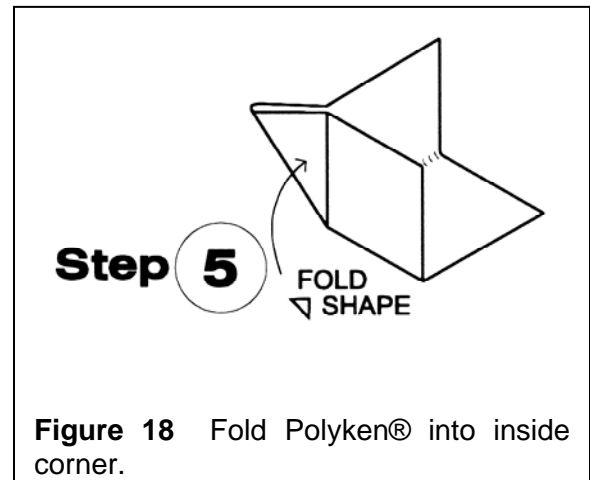

Figure 18 Fold Polyken® into inside corner.

Step 6. Cut the release liner along one side of the triangular shape. See Figure 19.

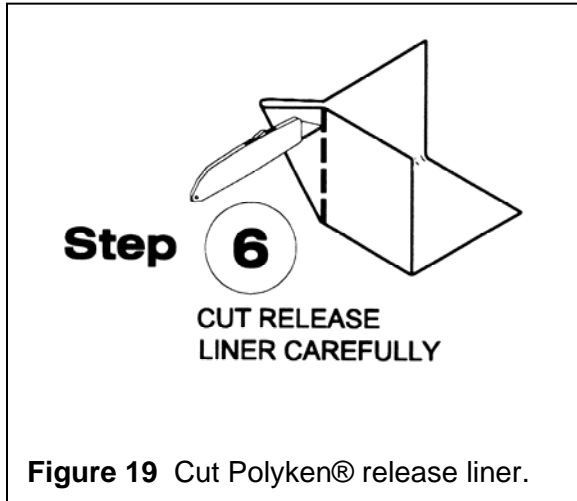

Figure 19 Cut Polyken® release liner.

Step 7. Peel away a portion of the release liner. See Figure 20.

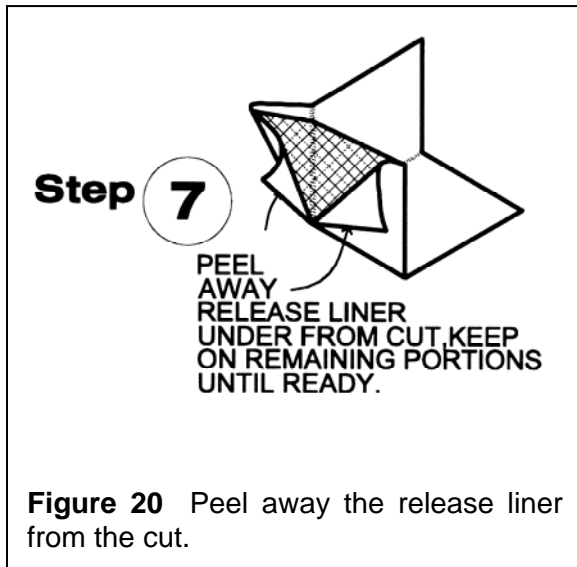

Figure 20 Peel away the release liner from the cut.

Step 8. Fold the triangular corner against the side to form a corner boot. See Figure 21.

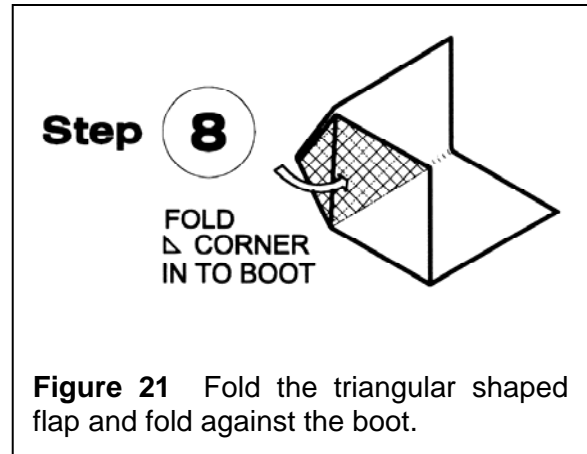

Figure 21 Fold the triangular shaped flap and fold against the boot.

Step 9. Press the triangular corner against the boot to form a tight bond. See Figure 22.

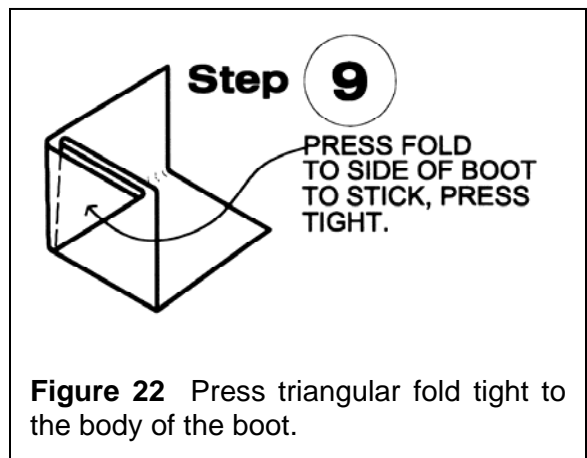

Figure 22 Press triangular fold tight to the body of the boot.

Step 10. The triangular fold of the inside corner boot must be oriented to fit a left-hand or right-hand inside corner so the fold is always down. See Figure 23.

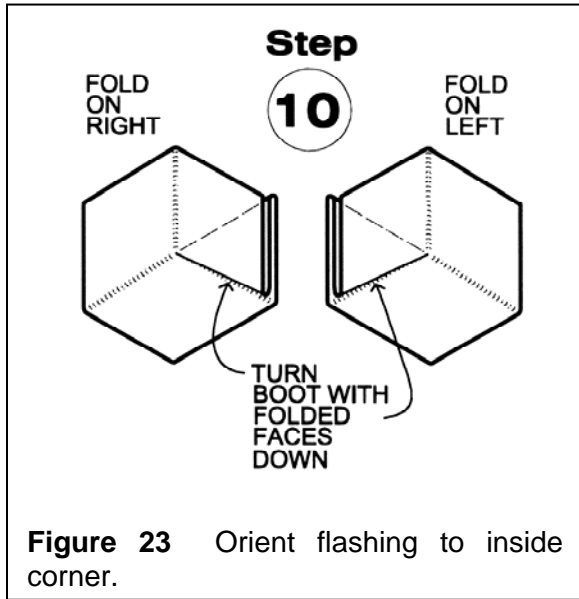

Figure 23 Orient flashing to inside corner.

Step 11. When placement has been checked, the remaining release liner can be removed in order to adhere the inside corner flashing firmly in place. See Figure 24.

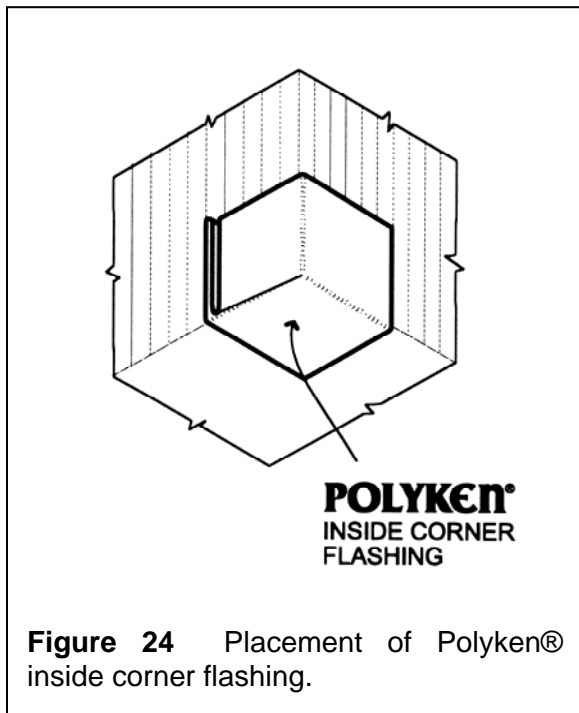

Figure 24 Placement of Polyken® inside corner flashing.

Outside Corner Flashing – Option 1

Outside corners can be made watertight with the use of Polyken® or Nashua® flashings. Multiple pieces (3 minimum) of Polyken® and Nashua® can be cut and applied to cover outside corners. The procedure is illustrated in Figures 25 to 32.

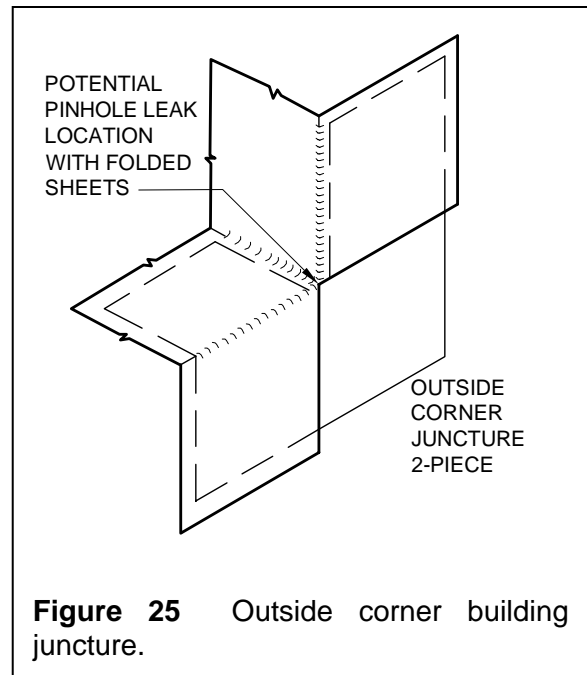

Figure 25 Outside corner building juncture.

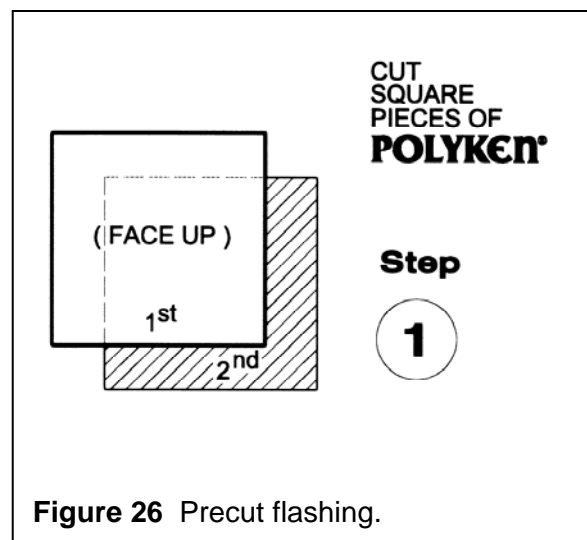

Figure 26 Precut flashing.

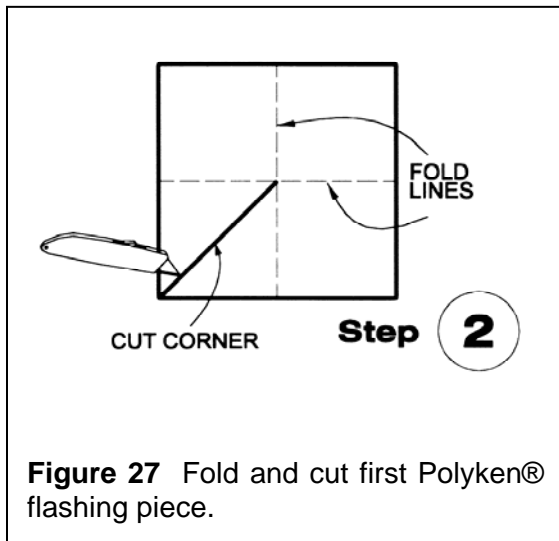

Figure 27 Fold and cut first Polyken® flashing piece.

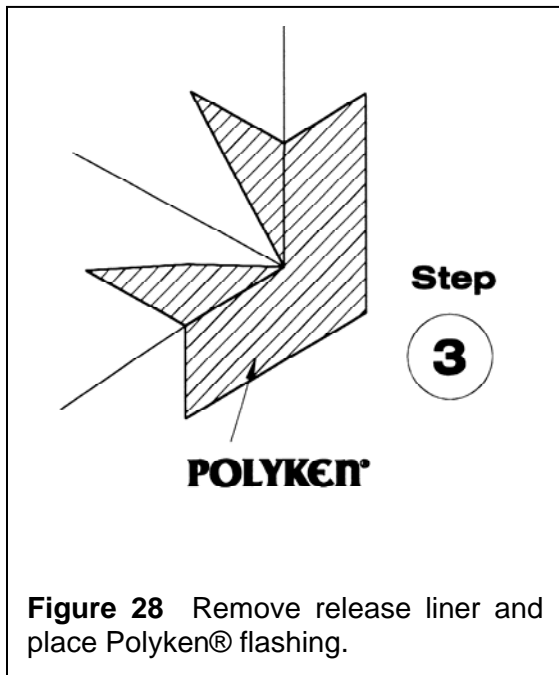

Figure 28 Remove release liner and place Polyken® flashing.

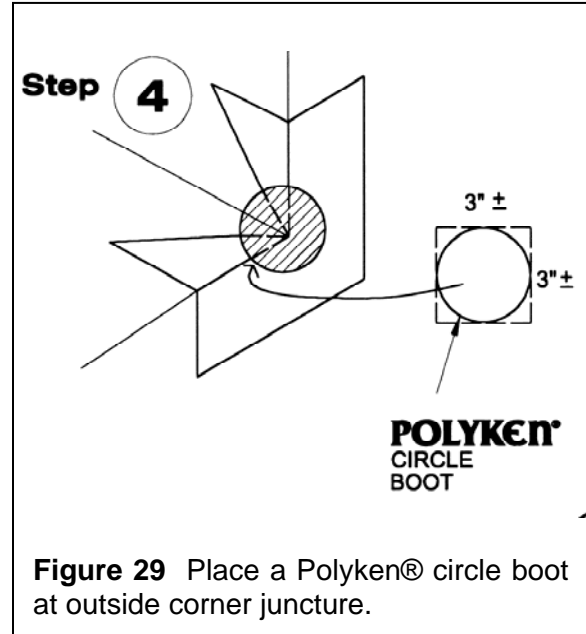

Figure 29 Place a Polyken® circle boot at outside corner juncture.

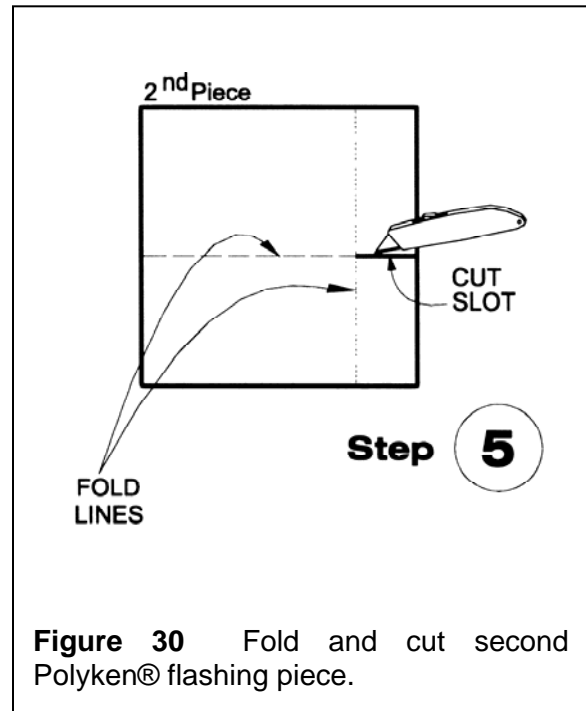

Figure 30 Fold and cut second Polyken® flashing piece.

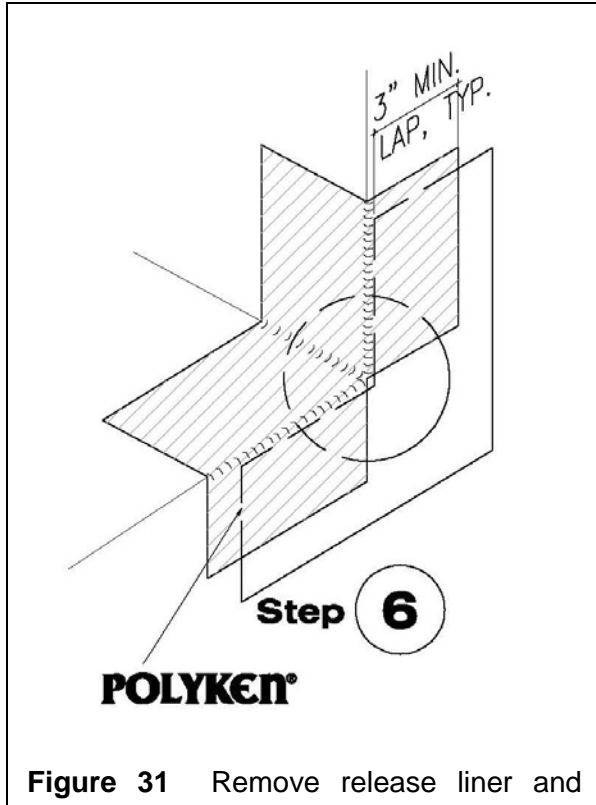

Figure 31 Remove release liner and

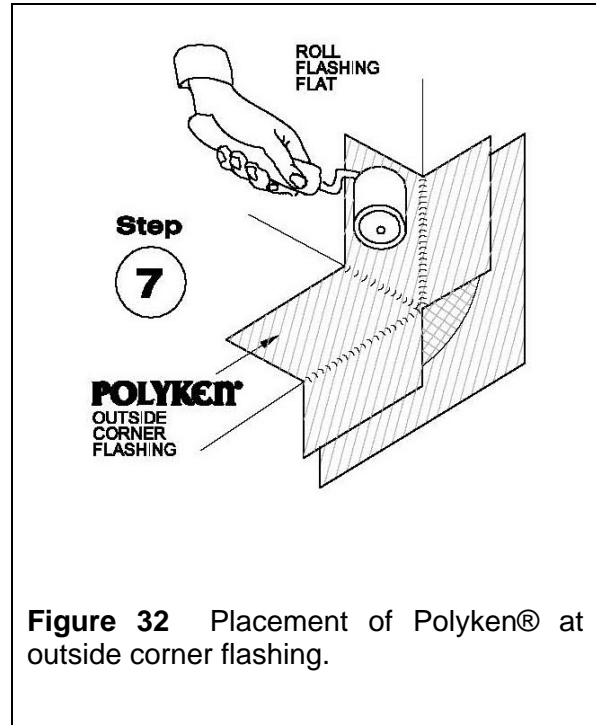

Figure 32 Placement of Polyken® at outside corner flashing.

Outside Corner Flashing – Option 2

The use of Nashua® contour flashing can result in a one-piece flashing strip at outside corners. This flashing procedure is illustrated in Manual Section 7.0.

Window/Door/Skylight Flashing Application Guide

Polyken® and Nashua® Flashing Tapes

Perimeter Opening Flashing

The successful installation of windows, doors, and skylights depends on the performance of the perimeter flashing of these fenestration products within the

building opening. Typical openings requiring flashings are shown in Figure 1. Polyken® and Nashua® Flashing Tapes provide superior waterproofing and durability characteristics for all of these building openings.

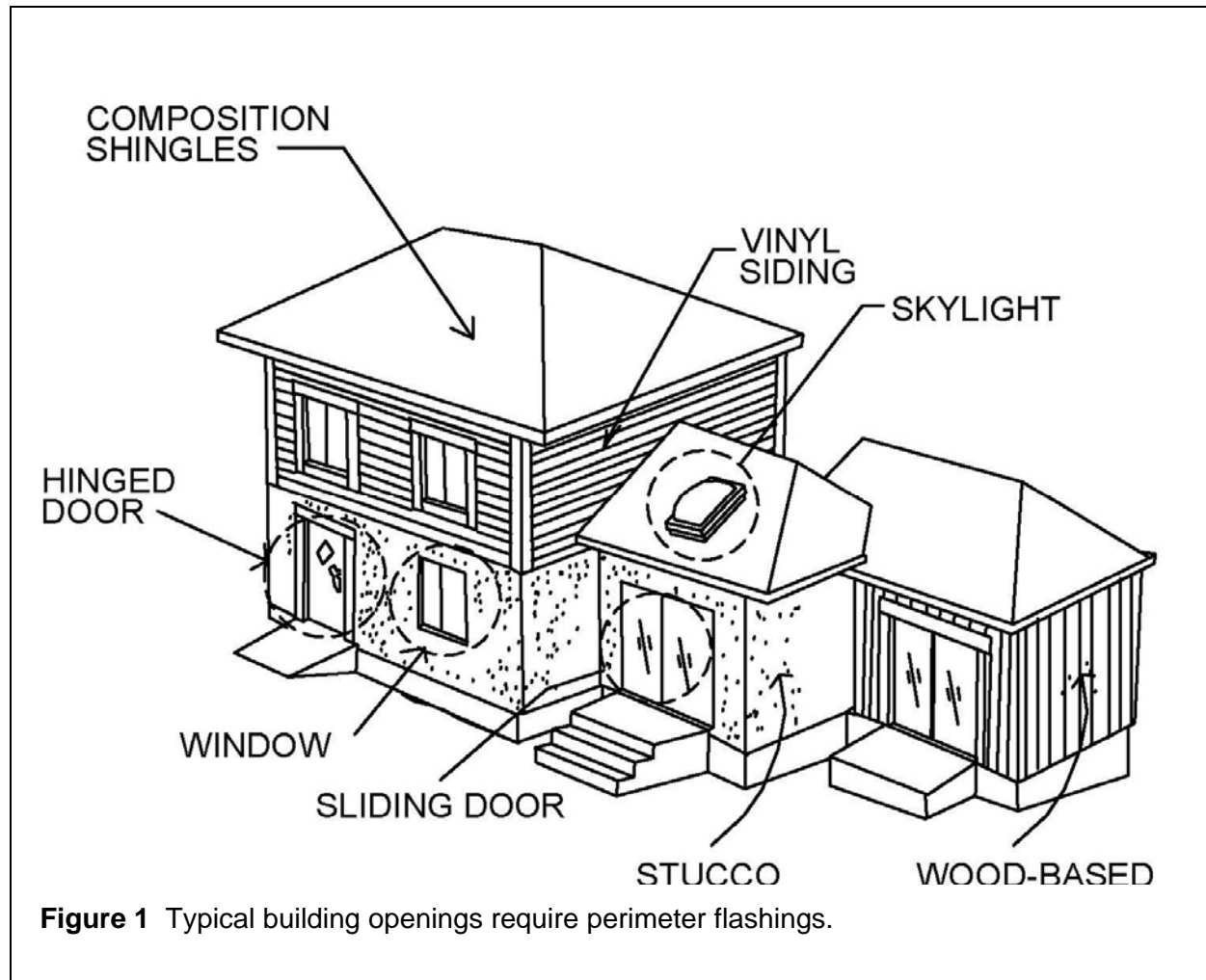

The use of Polyken® and Nashua® Flashing Tapes can accommodate different substrates and cladding materials to suit a

wide range of building design and construction variations.

Window & Door Flashing Details

The following flashing details represent a sample of the types of flashing procedures are commonly found in contemporary, wood-frame, residential and light commercial construction that utilize nail fin windows and door frames.

These flashing details are organized into categories based on ASTM E2112-07 Standard Practice for the Installation of Exterior Windows, Doors and Skylights.

In the ASTM publication, there are four variations of window/door perimeter flashing methods as described below. The choice of the particular method is left to the judgment of the building owner, design professional, and contractor for any particular project.

Method A

Jamb flashing applied over the window/door frame. Building paper is used as the weather-resistant barrier and is applied after the window/door installation.

Method A1

Jamb flashing applied over the window/door frame. Building paper or house wrap is used as the weather-resistant barrier and is applied before the window/door installation.

Method B

Jamb flashing applied under the window/door frame. Building paper is used as the weather-resistant barrier applied after the window/door installation.

Method B1

Jamb flashing applied under the window/door frame. Building paper or house wrap is used as the weather-resistant barrier applied before the window/door installation.

Illustrations for Methods A and A1

This Application Guide contains illustrations showing the use of Polyken® and Nashua® Flashing Tapes with Methods A and A1 for windows and doors. Methods B and B1 which often use Polyken® and Nashua® Flashing Tapes are conventional flashing procedures, and are not illustrated in this Application Guide.

Types of Window/Door Frames

There are basically two types of window and door frames to consider when selecting a method of perimeter flashing: Nail-on Fin (or flange) and Block Frame (non-finned). The frame materials used for either one of these two types of windows can be wood, aluminum, or vinyl/plastic.

Nail-On Fin (Attachment Flange)

Nail-on fin frames may use separate attachment fins for fastening the window/door to the building. The nail-on fin window/door can have either a non-integral fin or an integral fin. See Figures 2, 3 & 4. Typically, the separate attachment fin does not function as a flashing for the perimeter of the window/door.

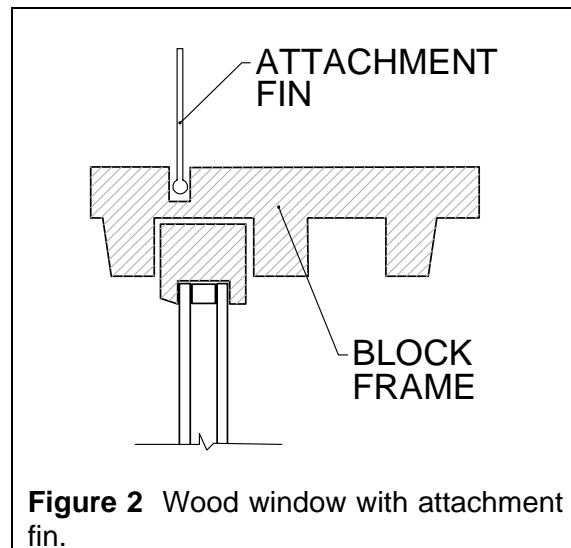

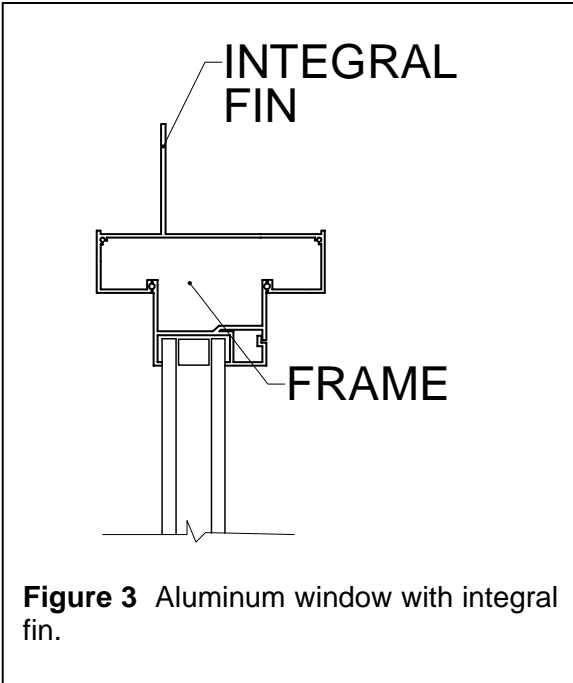

Non-integral fins

Non-integral nail-on fins are only for attachment of the window/door and are either applied to or inserted into the frame. These attached fins often do not provide a watertight connection to the frame. See Figure 5. Flashing for window/doors with a non-integral fin is accomplished similar to the block window conditions.

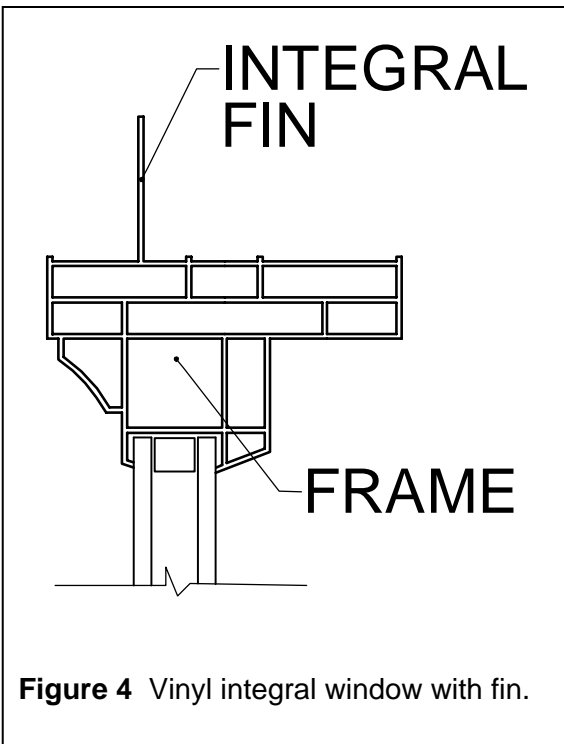
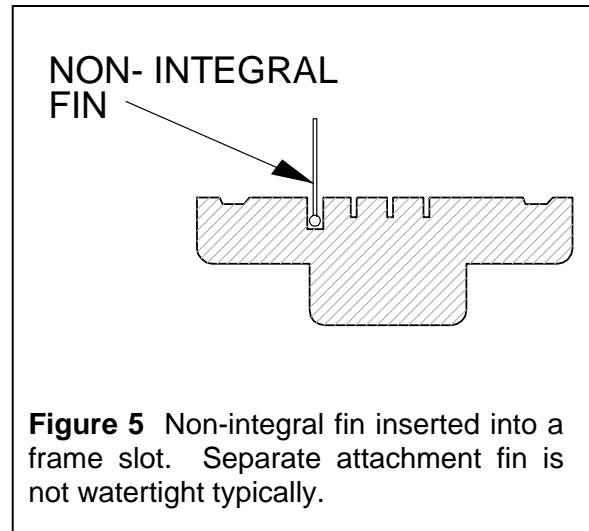

Integral fins

An integral fin is continuous with the frame (e.g., the fin of an extruded aluminum frame or the fin of molded vinyl frame). An integral fin generally is used as a component of the perimeter flashing for the window/door frame. See Figure 6. Polyken® or Nashua® flashing tape is adhered to a watertight nail-on fin thereby extending the effective width of the fin for integration with the weather-resistant barrier of the wall.

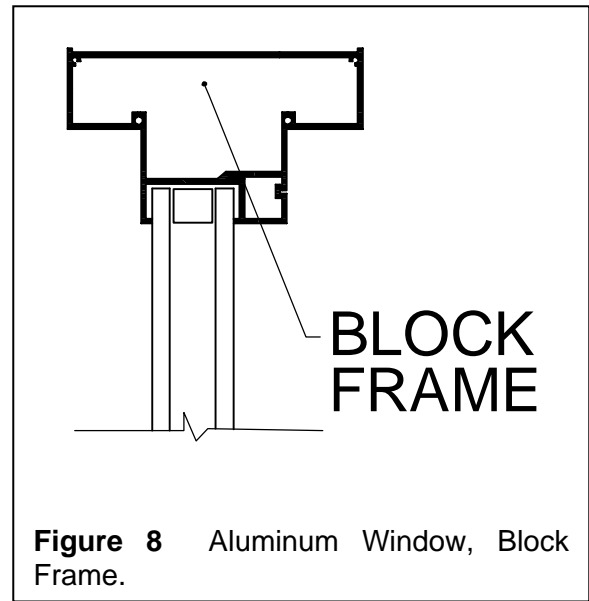
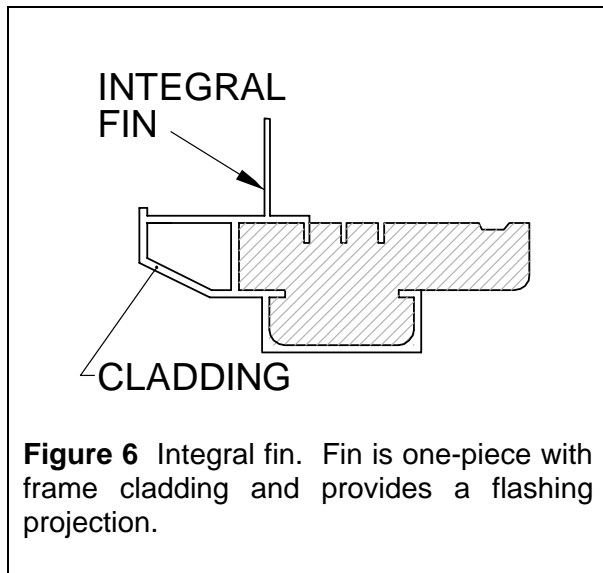

Block Frame Types

Block frames do not incorporate a projecting fin or flange for attaching the window or for flashing. Typical block frame sections are shown in Figures 7, 8 & 9.

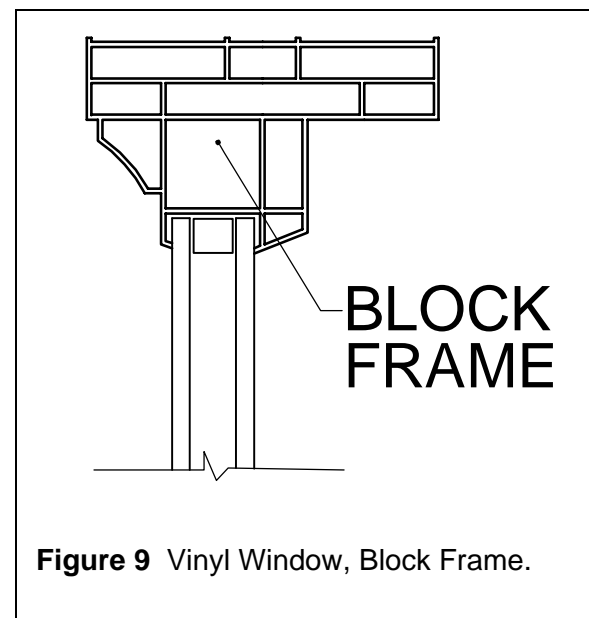
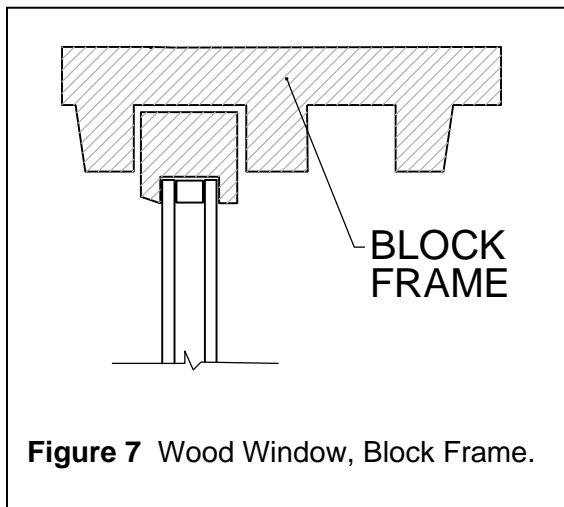

Block-framed products need to have a technique for connecting a perimeter flashing to the frame or provisions for sealing the perimeter and including a pan flashing at the head and sill to drain moisture out of the frame opening. See Figure 10.

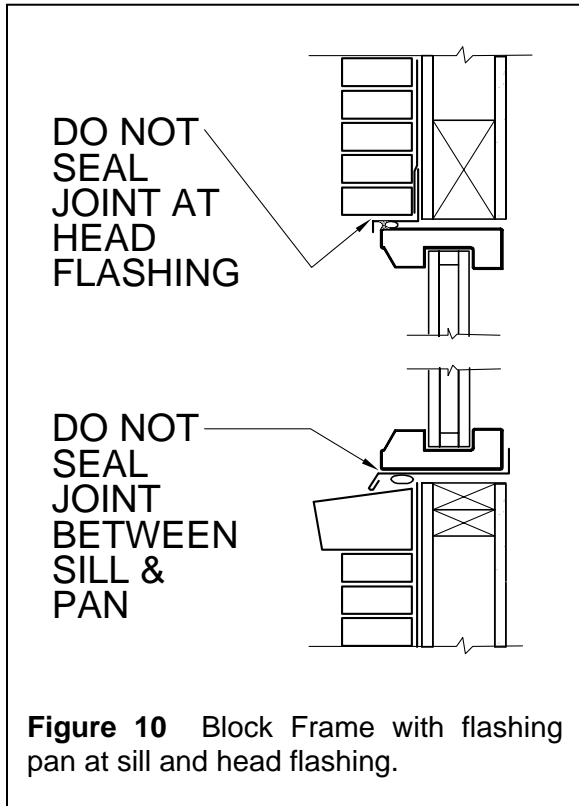

Figure 10 Block Frame with flashing pan at sill and head flashing.

Polyken® and Nashua® flashing tape are also used to flash block frame (non-finned) window and door frames. The techniques for flashing block frame windows/doors are described and illustrated in the “AAMA Installation Masters Training Manual” or the “ASTM E2112-07 Standard Practice for Installation of Exterior Windows, Doors and Skylights.”

Supplemental Head Flashing

A separate pre-formed head flashing (e.g., galvanized steel, stainless steel, copper or

vinyl) is recommended when the head unit of the frame is not capable of directing all water to the exterior.

Some examples of problem conditions with many window and door products which prevent complete drainage at the head of the unit are given below:

Condition 1: A flat head profile with a continuous raised outer lip creates a dam obstructing water flow immediately to the exterior. Water in this head is directed along the head toward the outer frame corners. See Figure 11.

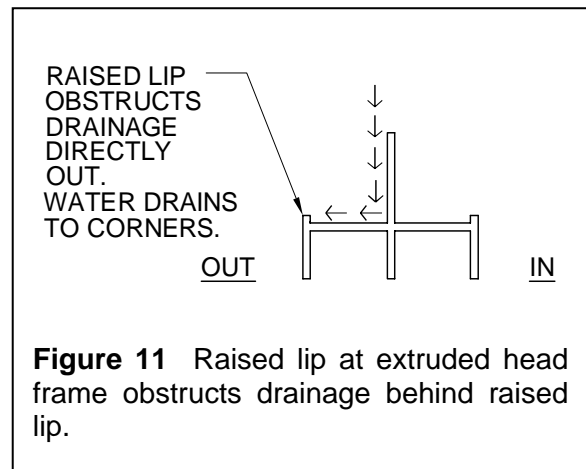

Figure 11 Raised lip at extruded head frame obstructs drainage behind raised lip.

Condition 2: A notched or open corner is provided with no factory, watertight corner seal. The open corner joint can allow water entry behind the otherwise watertight fin. Even with perimeter flashing along the head and up the jamb, the pinhole at the frame notch can allow water entry. See Figure 12.

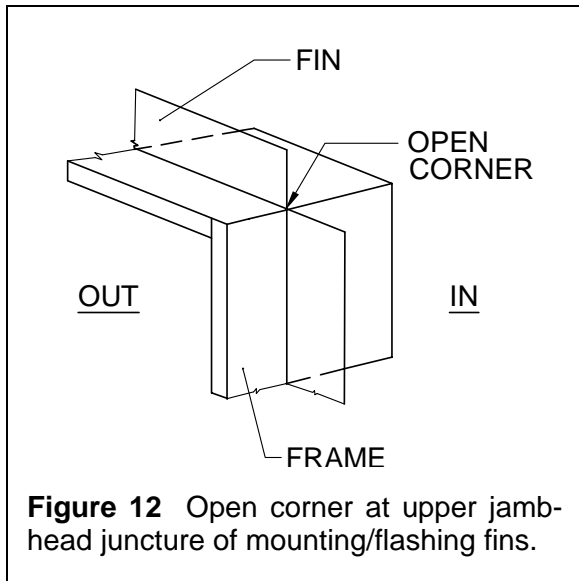

Figure 12 Open corner at upper jamb-head juncture of mounting/flashing fins.

Condition 3: Non-watertight nailing fin. When an inserted fin is used only for fastening the frame, water can enter behind or around the fin-to-frame connection. See Figure 13.

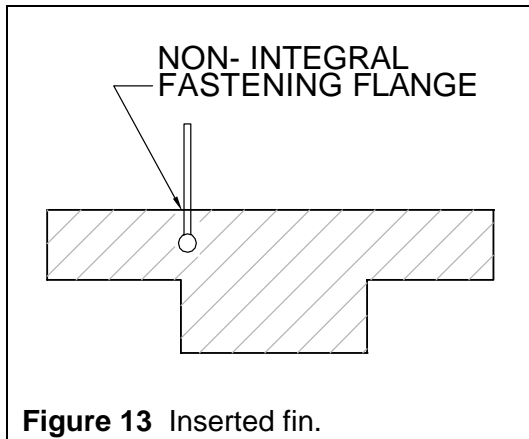

Figure 13 Inserted fin.

Condition 4: Head fin with holes. When the head fin has fastening holes, water can back up and enter through the holes. This condition is especially prevalent with vinyl windows since most vinyl windows have pre-punched frame fin holes. See Figure 14.

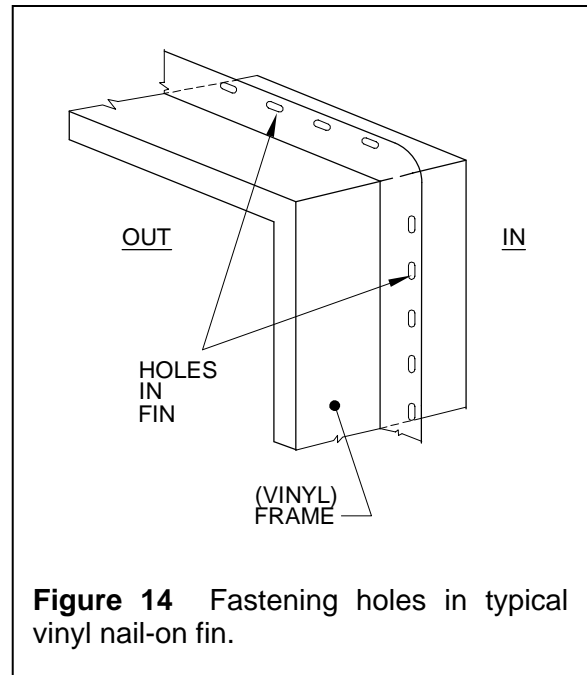

Figure 14 Fastening holes in typical vinyl nail-on fin.

Condition 5: Head trim. When head trim is applied over the head frame, two horizontal joints can occur potentially allowing water entry. See Figure 15.

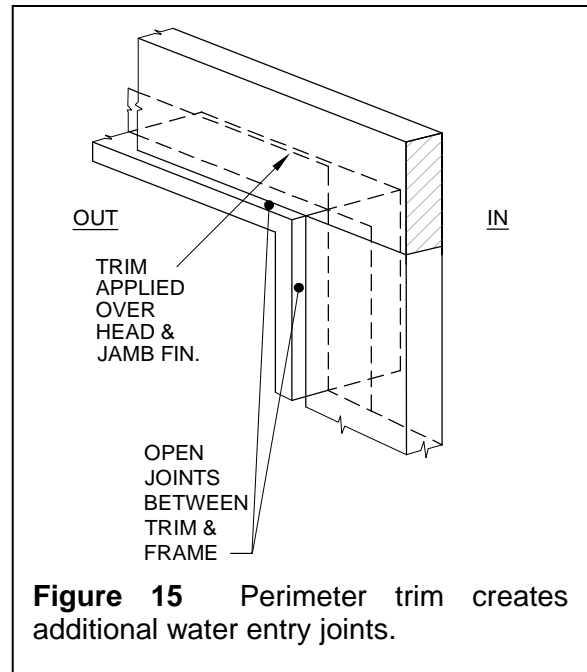

Figure 15 Perimeter trim creates additional water entry joints.

Supplemental Polyken® and Nashua® Flashing Solves Problems

In lieu of metal head flashing, Polyken® and Nashua® flashing tapes can be used to provide watertight integrity for Conditions 2, 3, and 4 above. Polyken® and Nashua® flashings can be accomplished as follows:

Condition 2: Patching open corner notch in fin

Step 1. Apply Polyken® and Nashua® circle boot at position of the potential pinhole. See Figure 16.

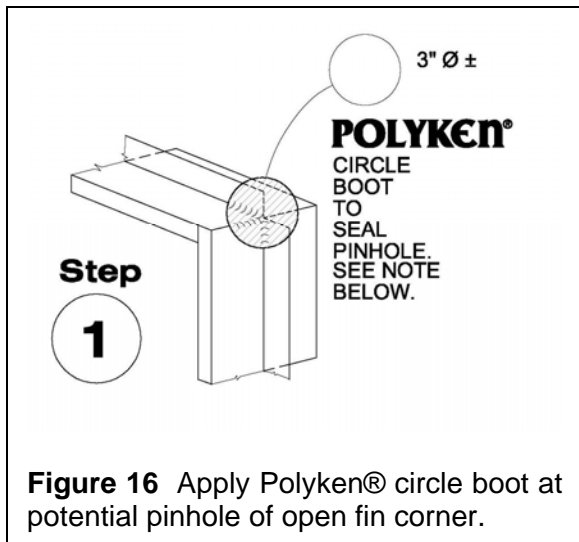

Figure 16 Apply Polyken® circle boot at potential pinhole of open fin corner.

Note: Alternate—Use Contour flashing for circle boot to conform to corner.

Step 2. Cut an “L” from a piece of Polyken® as shown in Figure 17.

Note: Alternate—Use Nashua® Contour flashing for corner flashing.

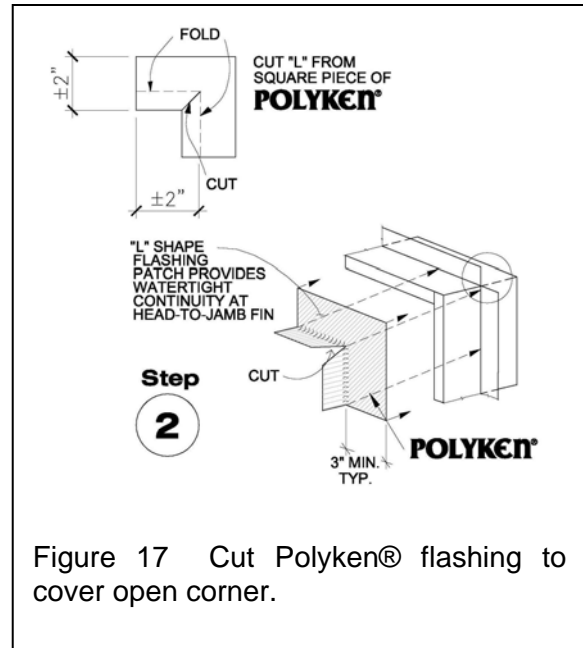

Figure 17 Cut Polyken® flashing to cover open corner.

Step 3. Apply Polyken® “L” to shape strip to head-jamb juncture. See Figure 18.

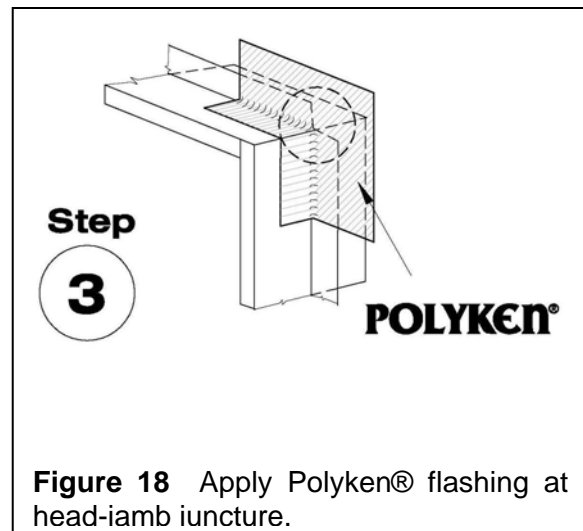

Figure 18 Apply Polyken® flashing at head-iamb iuncture.

Condition 3: Non-watertight nailing fin. Apply Polyken® or Nashua® flashing tape to the attachment fin and onto frame to provide watertight flashing. Lap flashing sufficiently onto the frame and fin surfaces to maintain uniform and continuous

adhesion. See Figure 19. Note: Adhesion to fin and frame material needs to be confirmed with door/window manufacturer. Rolling flashing onto the attachment fin and frame is critical for proper adherence for long-term performance.

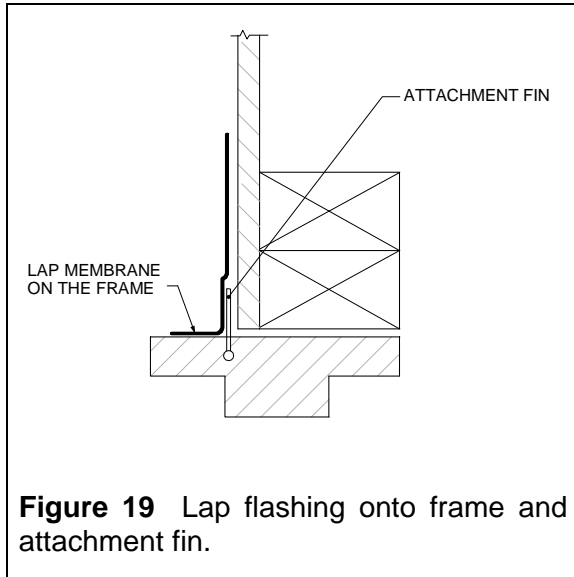

Figure 19 Lap flashing onto frame and attachment fin.

Step 1. Apply flashing on the sides of frame and fin and roll for maximum adhesion. See Figure 20.

Step 2. Apply a circle boot at the corner where a pinhole would occur. See Figure 21.

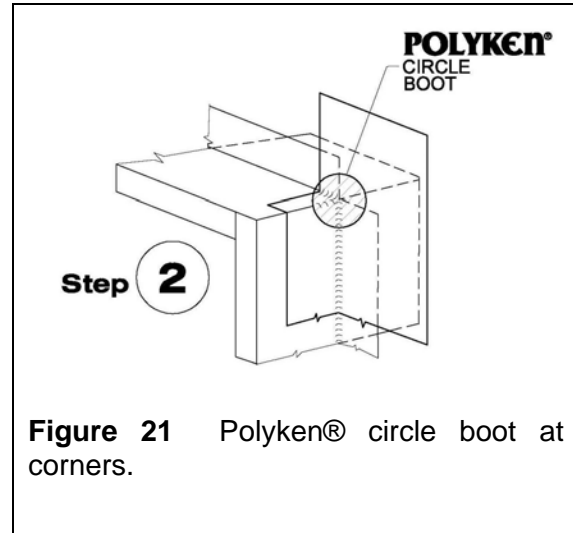

Figure 21 Polyken® circle boot at corners.

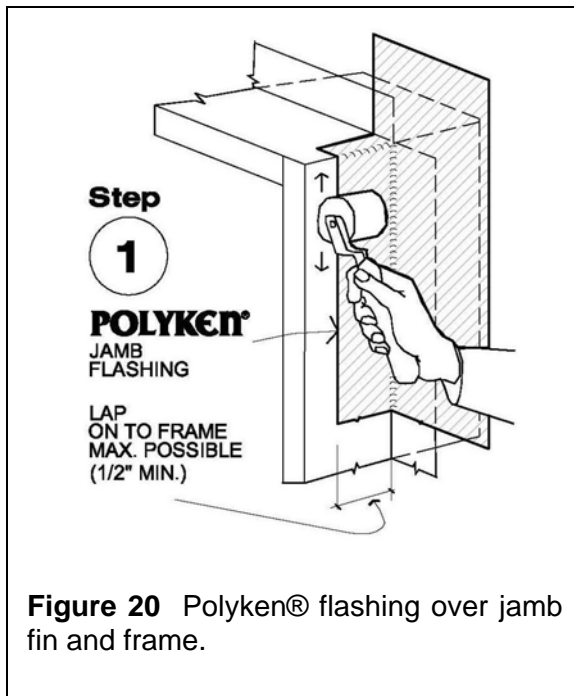

Figure 20 Polyken® flashing over jamb fin and frame.

Step 3. Apply Polyken® or Nashua® flashing across the head of the frame and roll all head flashing. See Figure 22.

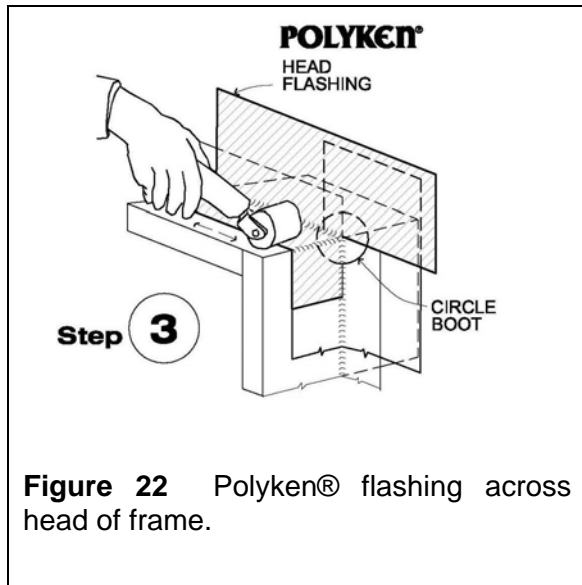

Figure 22 Polyken® flashing across head of frame.

Condition 4: Use flashing tape to cover fin fastening holes at head and jamb. Polyken® flashing applied over the fin holes can prevent water entry. See Figure 23.

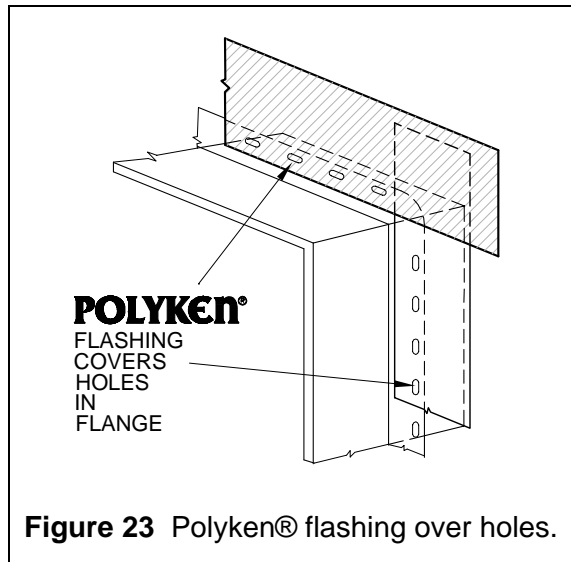

Figure 23 Polyken® flashing over holes.

Supplemental Head Flashing – Lapping the Top

Conditions 1, 2, 3, and 4: The use of supplemental head flashing should include the provision for Polyken® or Nashua® flashing tape applied over the top of the vertical leg of the supplemental head flashing. See Figure 24.

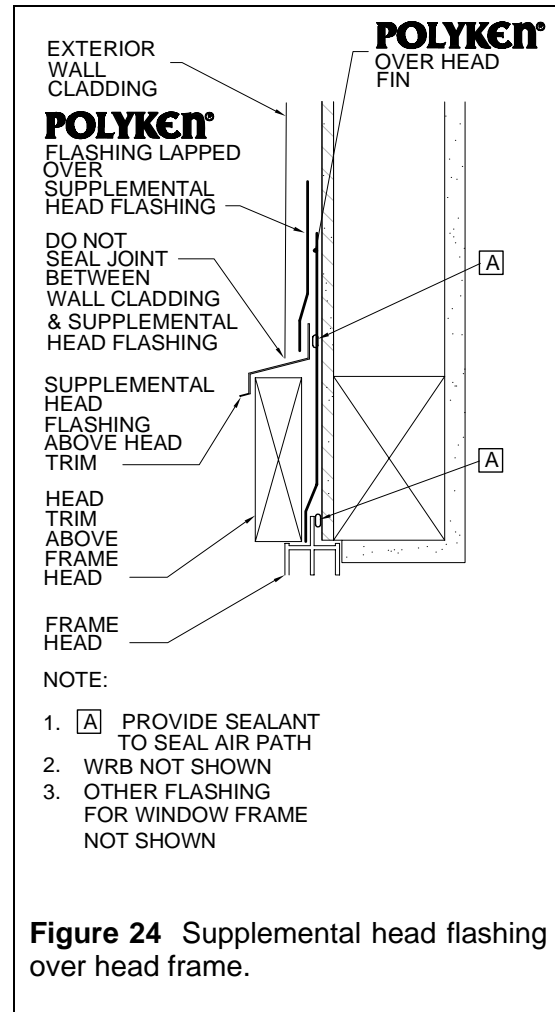

Figure 24 Supplemental head flashing over head frame.

Condition 5: Supplemental head flashing is also recommended for trim over the head frame. Many window and door perimeters are trimmed out with an additional piece of exterior casing. Supplemental head flashing can address the horizontal joint created at the trim cladding juncture above the head. See Figure 25.

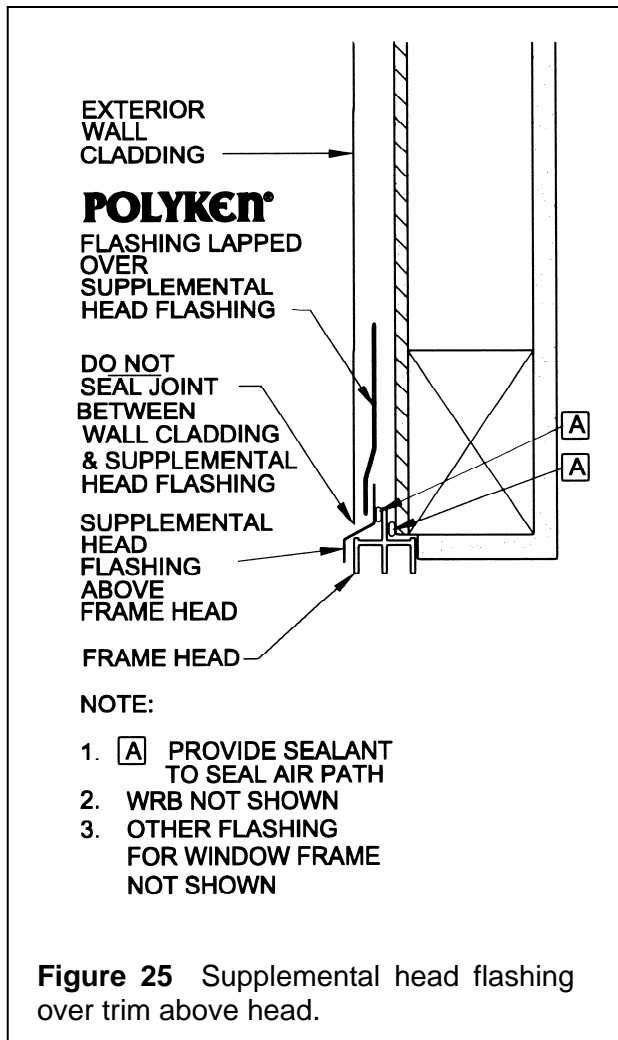

Figure 25 Supplemental head flashing over trim above head.

When supplemental head flashing is provided along the top of head trim, the flashing must extend to the end of the trim. See Figure 26.

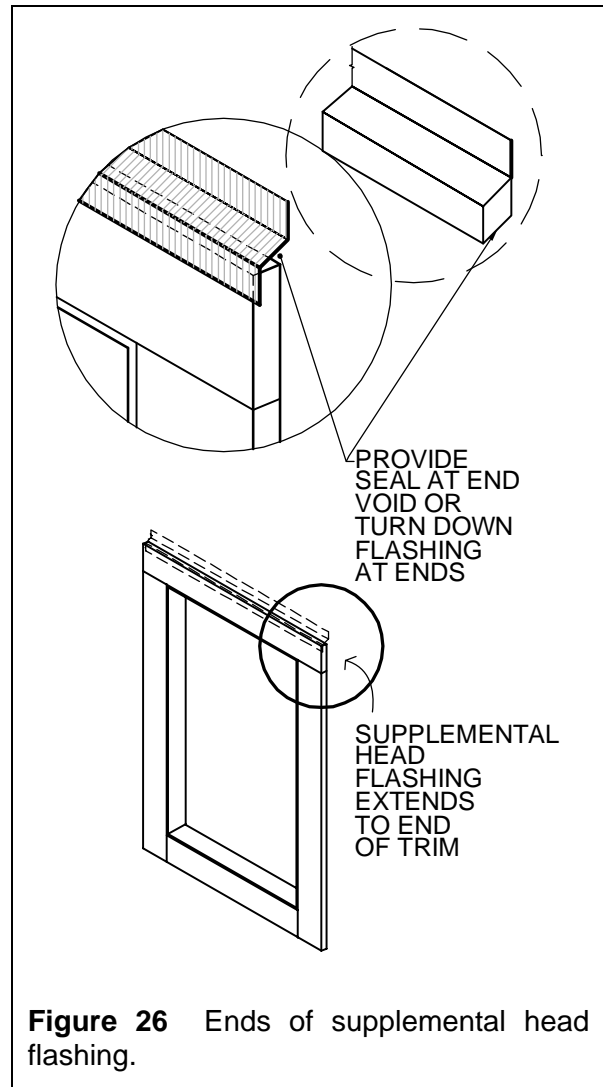

Figure 26 Ends of supplemental head flashing.

Considerations for Cladding Materials

Generally, the cladding material for most residential and light-commercial buildings relies upon a weather-resistant barrier (WRB), such as building paper or an air barrier (house wrap) that is installed underneath the cladding.

The exterior cladding prevents most of the water entry, and the WRB takes care of the incidental water that inevitably finds its way past the cladding. The perimeter opening flashings are an essential part of the complete WRB and cladding system.

Wood-Based Siding and Trim

Wood-based siding, such as clapboards, plywood panels, and shingles, should be separated from window and door frames with a gap that is sealed. The gap dimension may vary depending on the product from 1/8" to 1/2" minimum. When trim around the opening and frame is used, it must also be separated with a gap and sealed.

Stucco

Stucco is often applied up to the window/door frame without a perimeter trim. In such case, no perimeter seal between stucco and frame is provided.

When no perimeter seal to the frame is added, the underlying WRB and perimeter flashing needs to be durable in order to withstand recurring and direct water entry from the narrow gap at the stucco to frame joint.

The condition of the sill flashing and the lathing for the stucco needs attention if paper-backed lath assembly is used. The paper and wire must be separated and the top of the paper in the assembly must be installed under the sill flashing, while the wire lath of the assembly must be over the sill flashing.

Vinyl

Vinyl siding is applied over a WRB and perimeter opening flashing similar to wood-based claddings. When perimeter trim is used around openings, it should be sealed to the fenestration frame and to the vinyl wall siding.

Sill/Threshold Pan Flashing

Sill/threshold pan flashings supplement the perimeter flashing system at the bottom of window and door products. Sill (threshold) pans are generally recommended at all door threshold locations, except where sill nail-on fin frames are used. Sill pans are recommended for all block frame windows.

The sill pan can either direct water from the opening to drain to the exterior of the cladding or to the surface of the weather-resistant barrier behind the cladding. See Figures 27 and 28. ASTM E2112-07 recommends sill pans for all types of windows and doors.

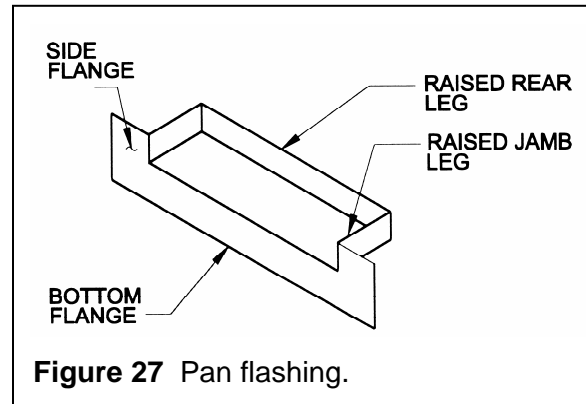

Figure 27 Pan flashing.

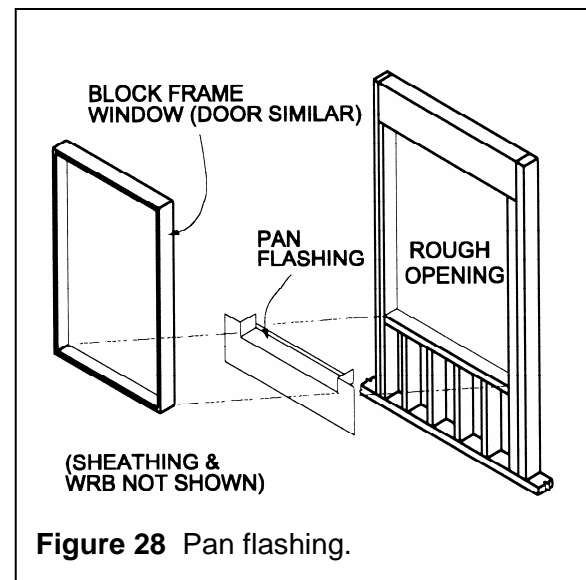
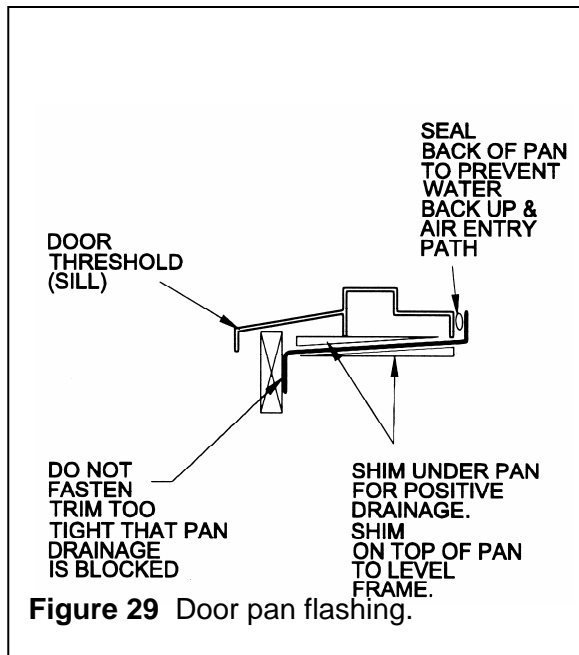

Figure 28 Pan flashing.



- Type 3: Deck Mount
- Type 4: Inset Mount

A diagram illustrating each of the four types is shown under Flashing Sequence Diagrams on page 6.23.

The perimeter flashing for the four types of skylights is shown in the Polyken® Application details for use with composition shingles. The flashing is similar for other shingle products including wood and cement-based where there is a solid substrate and a uniform application of a roof underlayment, such as asphalt saturated felt.

Polyken® or Nashua® circle boots can be used at the curb junctures of skylight flashings. Also, Polyken® and Nashua® circle boots will conform to vertical and horizontal planes at outside corners. See Figures 31 & 32.

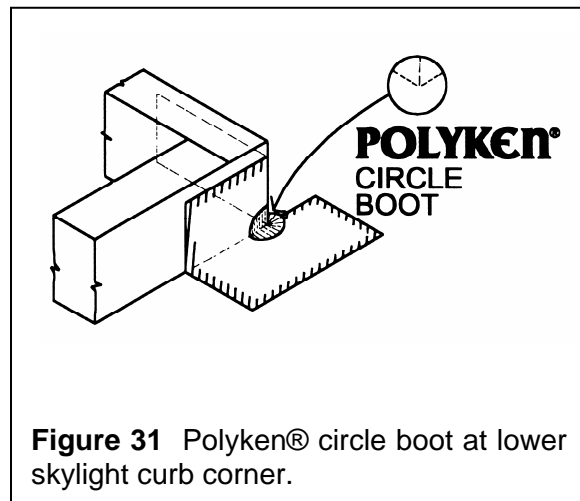
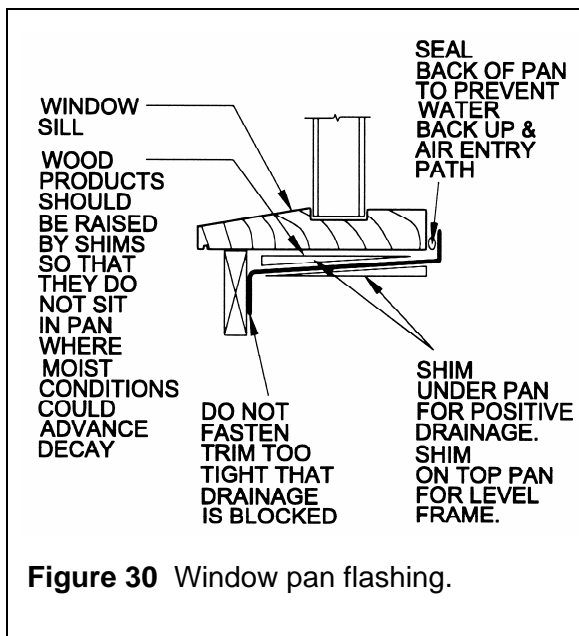

Considerations for Skylight Flashing

There are four classes of skylights from the ASTM E2112 Standard:

- Type 1: Flush Mount
- Type 2: Curb Mount

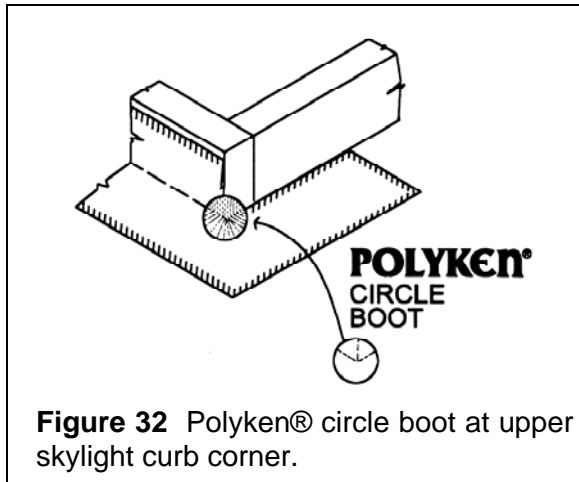

For all skylights it is important to counterflash the top of the skylight saddle or cricket with a strip of roof underlayment that is also counterflashed by roof underlayment further upslope. See Figure 33. With curb mount skylights, turn up the roof underlayment onto the curb. See Figure 34.

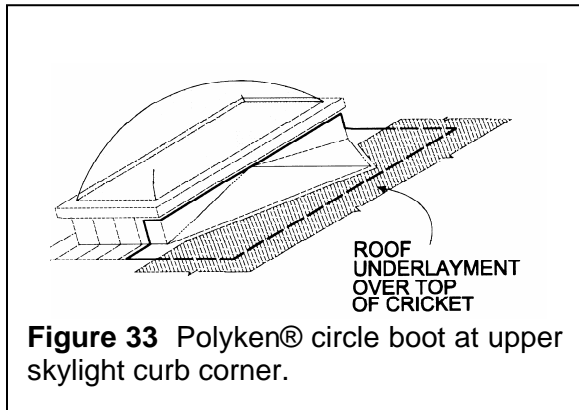

See the flashing sequence diagrams for more specific information on skylight flashings.

For roof covering products such as tiles, slate, and wood shakes, the perimeter skylight flashing would vary from the details shown in the Polyken® and Nashua® Application details.

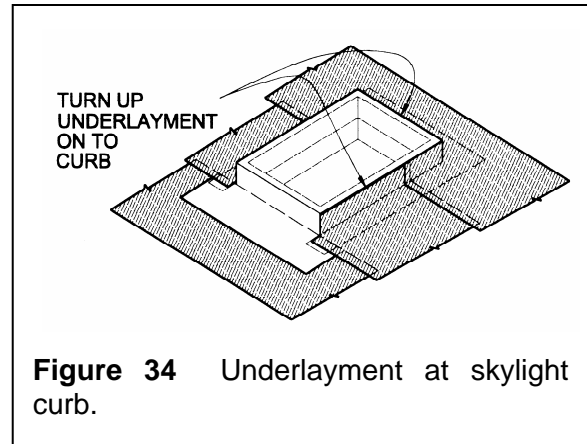

Consult with the specific roofing and skylight product manufacturer to verify the suitability and application of the Polyken® and Nashua® perimeter skylight flashing systems.

Replacement Windows and Doors

The flashing installation for replacement window and door products is similar to new installations when the exterior cladding is removed around an opening for a sufficient distance to access the existing perimeter flashings.

The installation of the replacement window/door with nail-on fins requires the removal of a portion of the perimeter cladding and the removal of the existing frame. Flashing Methods SAF, A and A1 using Polyken® and Nashua® flashing tapes are an extremely effective and efficient procedure to tie-in the new flashing to the existing flashing or weather resistant barrier. Usually, where exterior cladding is not removed, nail-on windows/doors are not used.

For replacement of block frame windows and doors, or where the exterior cladding around the perimeter is not removed, follow the procedures given in the AAMA Installation Masters Training Manual or the ASTM E2112 Standard Practice for Installation of Exterior Windows, Doors and Skylights.

Flashing Detail Selection

Polyken® and Nashua® Flashing Tapes

The choice of flashing methods depends on the type of window, door, or skylight frame selected. Further, the type of weather-resistant barrier to be used limits the flashing methods available. The following table is intended to assist with the selection of appropriate flashing details. The specific flashing details are outlined on the following pages.

The window and door flashing details show the use of Polyken® and Nashua® Flashing Tapes with Nail-Fin type frames for windows and block frames for doors. The flashing details are appropriate with the use of most exterior wall claddings, e.g., 3-coat stucco, wood & vinyl sidings and plywood panel systems using a concealed weather-resistant barrier under the cladding. The Skylight flashing details show a composition shingle roof covering on solid, sloped roof sheeting.

The project designer is responsible to adapt flashing details for specific types of wall claddings and roof coverings, e.g., clay tile, concrete tile, wood shingles and shakes, and panel systems.

POLYKEN® AND NASHUA® FLASHING DETAIL SELECTION								
Application Variables	Flashing Method With Polyken® and Nashua®							
	Windows			Doors			Skylights	
Underlayment (Weather-Resistant Barrier):								
• Building Paper	A	(similar to A)	SAF	A	(similar to A)	SAF	-	-
• Housewrap	-	A1	SAF	-	A1	SAF	-	-
• Roof Felt Underlayment	-	-	-	-	-	-	SP-1/3	SP-2/4
Mounting Window/Door:								
• Integral Nail Fin	A	A1	SAF	(similar to windows)			-	-
• Applied Nail Fin	(similar to doors)			A	A1	SAF	-	-
• Block Frame w/Field-Applied Brick Mold	See Application Guide			See Application Guide			-	-
• Block Frame w/Factory-Applied Brick Mold	See Application Guide			See Application Guide			-	-
• Block Frame w/o Brick Mold	See Application Guide			See Application Guide			-	-
Skylight:								
• Integral Deck Flange	-	-	-	-	-	-	SP-1/3	-
Skylight:								
• Deck Curb w/o Flange	-	-	-	-	-	-	-	SP-2/4
Supplemental Flashings:								
• Head Flashing	(similar to doors)			A	A1	SAF	-	-
• Sill Pan (Block Frame)	(similar to doors)			A	A1	SAF	-	-
	Contour			Similar to windows				

Note: For ASTM Flashing Methods B & B1 using Polyken® Flashing Tapes, refer to ASTM E2112-07 Standard Practice for Installation of Exterior Windows, Doors and Skylights.

For Flashing doors and windows with Block Frame mountings refer to AAMA Installation Masters Training Manual, # IM - TM, June 2000.

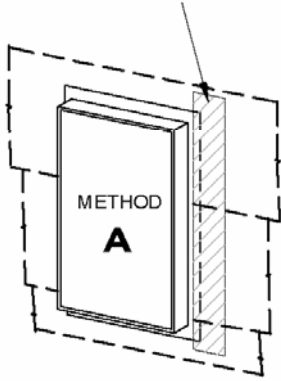
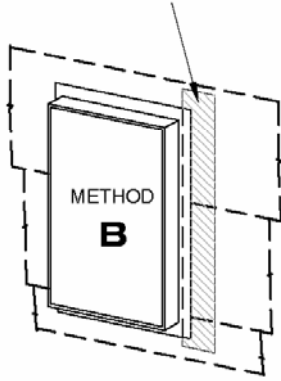
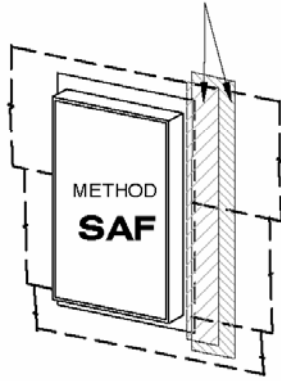
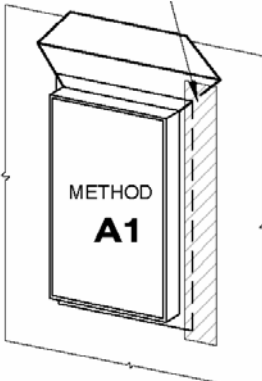
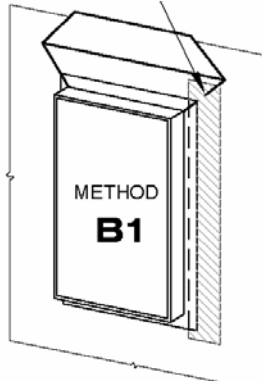
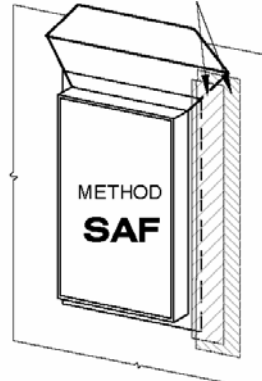
WINDOWS/DOOR FLASHING METHODS		
ASTM E 2112 DESIGNATION		POLYKEN® & NASHUA® DESIGNATION
<p>Method A POLYKEN® JAMB FLASHING OVER FRAME FLANGE</p>  <p>BUILDING PAPER LAPS OVER JAMB FLASHING</p>	<p>Method B POLYKEN® JAMB FLASHING UNDER FRAME FLANGE</p>  <p>BUILDING PAPER LAPS OVER JAMB FLASHING</p>	<p>Method SAF POLYKEN® JAMB FLASHING OVER & UNDER FRAME FLANGE</p>  <p>BUILDING PAPER LAPS OVER JAMB FLASHING</p>
<p>Method A1 POLYKEN® JAMB FLASHING OVER FRAME FLANGE</p>  <p>HOUSEWRAP APPLIED 1ST UNDER JAMB FLASHING</p>	<p>Method B1 POLYKEN® JAMB FLASHING UNDER FRAME FLANGE</p>  <p>HOUSEWRAP APPLIED 1ST UNDER JAMB FLASHING</p>	<p>Method SAF POLYKEN® JAMB FLASHING OVER & UNDER FRAME FLANGE</p>  <p>HOUSEWRAP APPLIED 1ST UNDER JAMB FLASHINGS</p>

Notes: Separate head and sill Polyken® and Nashua® flashings not shown for clarity.
 The SAF method can be used with both types of WRB – House wrap and building paper.
 The outline of the building paper lapping over the jamb and head flashing is shown dashed.

Flashing Method	Details		
	Head	Jamb	Sill
Window Nail-Fin			
Method A (building paper)	W.A.1	W.A.2	W.A.3
Method A1 (house wrap)	W.A.1.1	W.A.1.2	W.A.1.3
Method SAF	W.SAF.1	W.SAF.2	W.SAF.3
Door (swing type) Block Frame			
Method A (building paper)	D.A.1	D.A.2	D.A.3
Method A1 (house wrap)	D.A.1.1	D.A.1.2	D.A.1.3
Method SAF	D.SAF.1	D.SAF.2	D.SAF.3
Skylight			
Type 1 or Type 3	SP.1.1	SP.1.2	SP.1.3
Type 2 or Type 4	SP.2.1	SP.2.2	SP.2.3

WINDOW FLASHING - METHOD SAF (HOUSEWRAP)

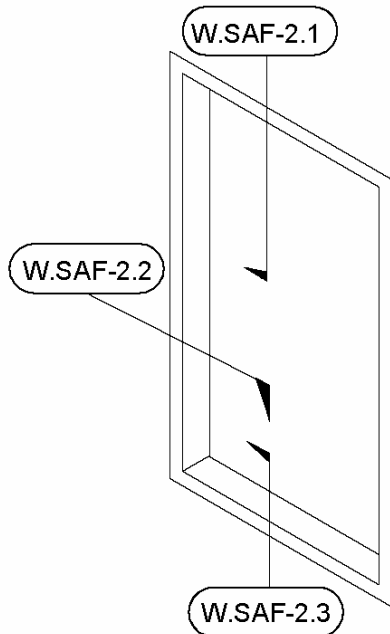

- MATERIALS KEY:**
- A** HOUSEWRAP - WEATHER-RESISTANT BARRIER (WRB)
 - B** SEALANT BEAD
 - C** WINDOW FRAME
 - D** WALL SHEATHING
 - E** EXTERIOR WALL CLADDING

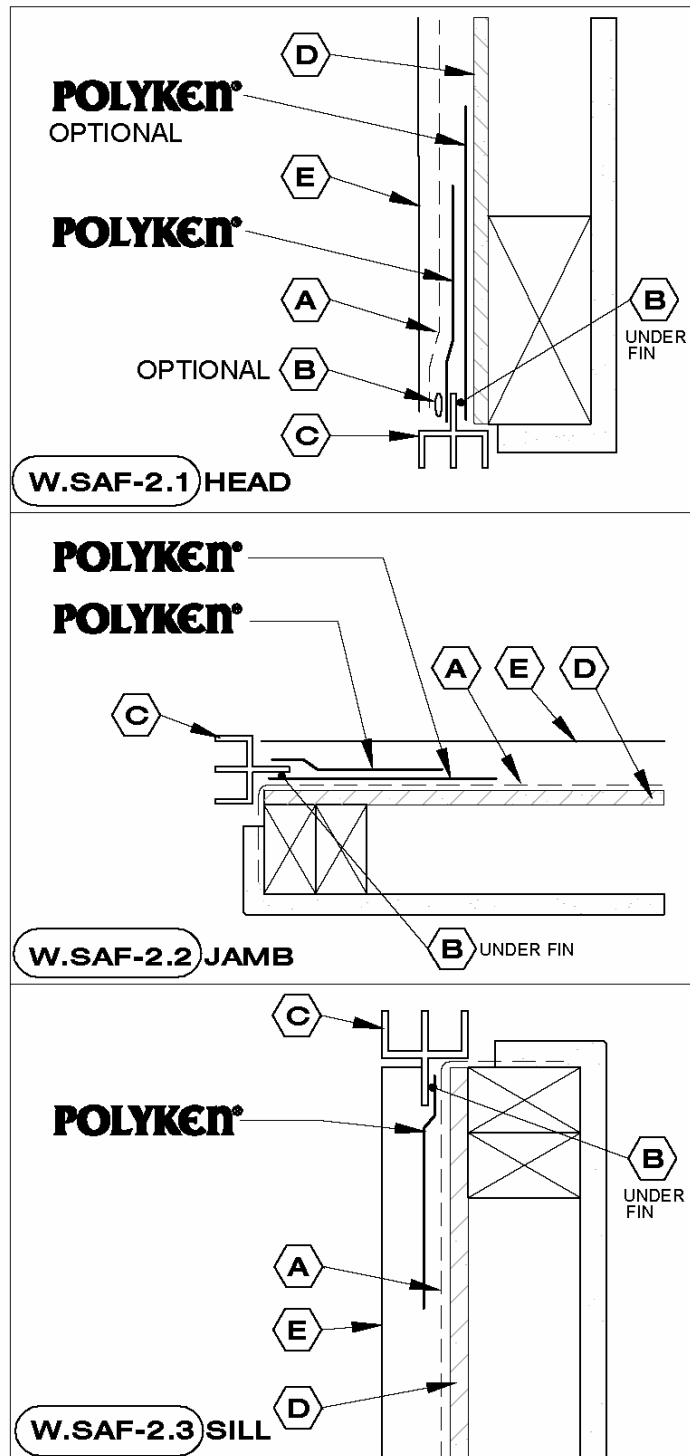

WINDOW FLASHING - METHOD A1 (HOUSEWRAP)

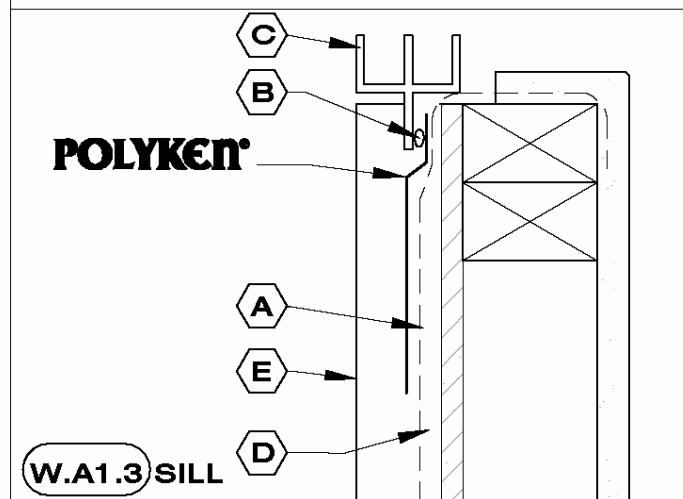
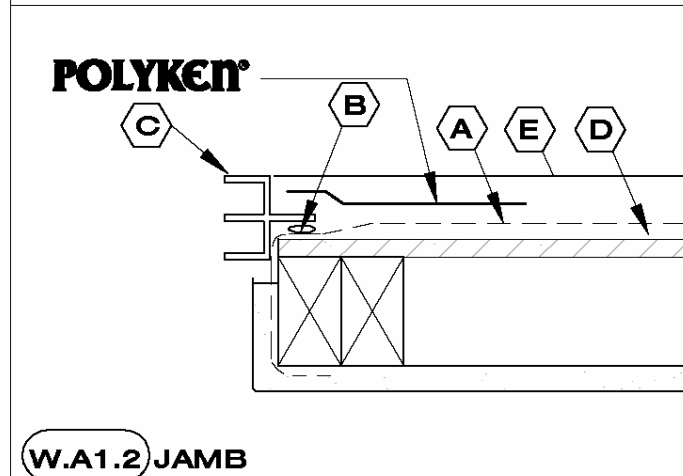
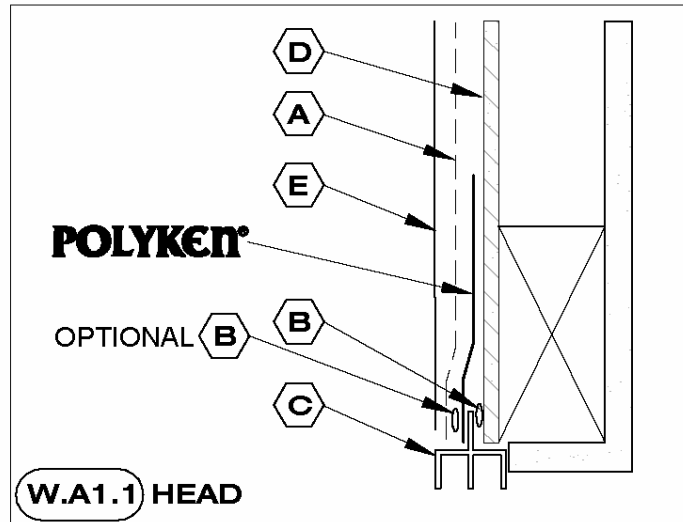
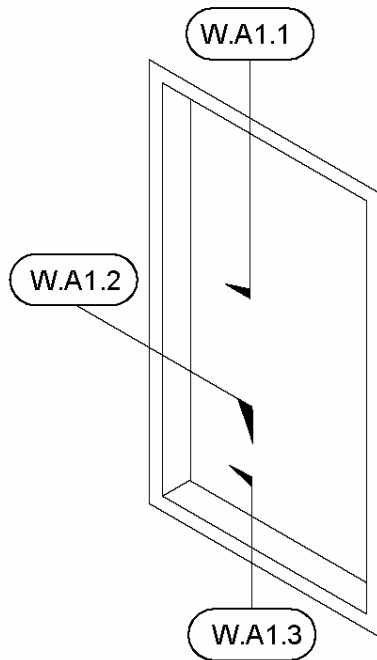

MATERIALS KEY:

- A** HOUSEWRAP - WEATHER-RESISTANT BARRIER (WRB)
- B** SEALANT BEAD
- C** WINDOW FRAME
- D** WALL SHEATHING
- E** EXTERIOR WALL CLADDING

WINDOW FLASHING - METHOD A (BUILDING PAPER)

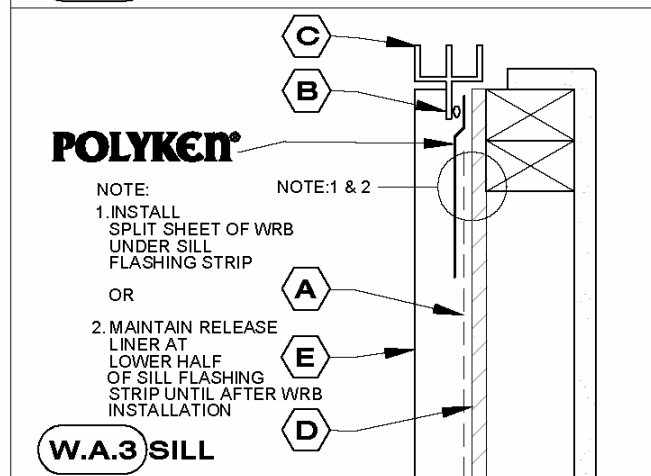
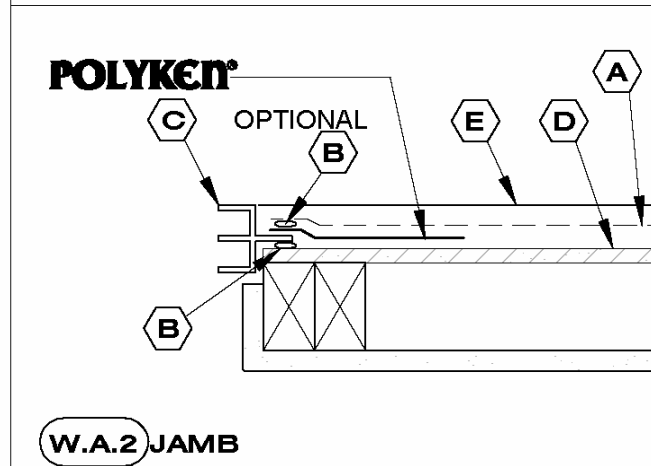
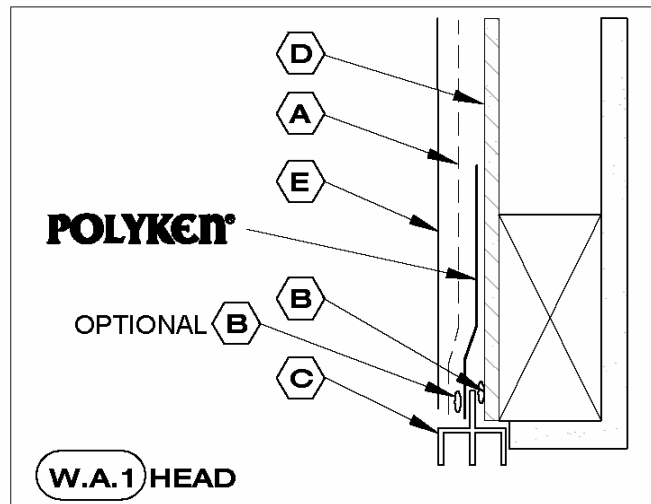
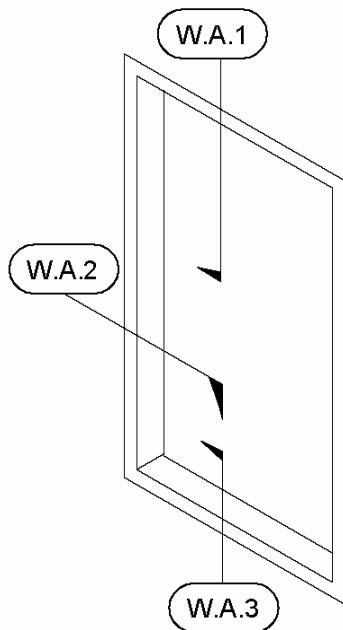

- MATERIALS KEY:**
- A** BUILDING PAPER
 - B** WEATHER-RESISTANT BARRIER (WRB)
 - C** SEALANT BEAD
 - D** WINDOW FRAME
 - E** WALL SHEATHING
 - E** EXTERIOR WALL CLADDING

WINDOW FLASHING - METHOD SAF (BUILDING PAPER)

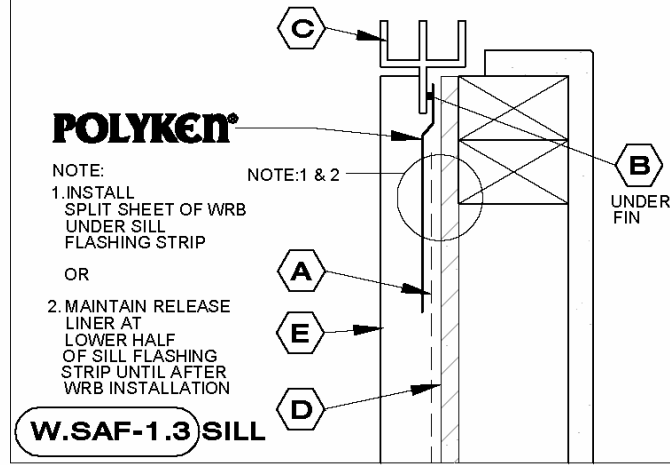
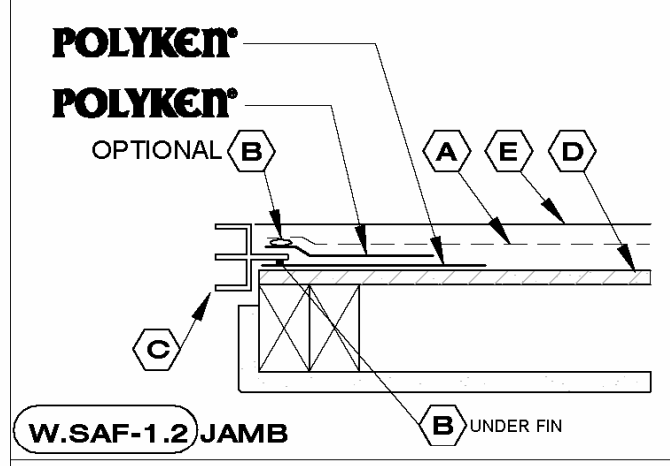
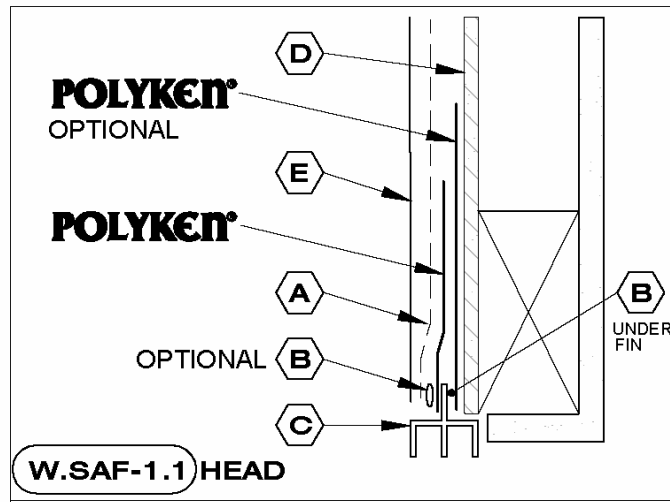
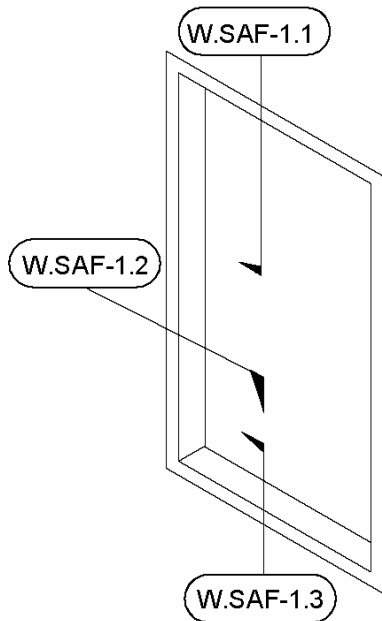

- MATERIALS KEY:**
- A** BUILDING PAPER - WEATHER-RESISTANT BARRIER (WRB)
 - B** SEALANT BEAD
 - C** WINDOW FRAME
 - D** WALL SHEATHING
 - E** EXTERIOR WALL CLADDING

DOOR FLASHING - METHOD A (BUILDING PAPER)

- NOTE:1
DOOR CAN BE INS WING,
OUT SWING OR SLIDER.
- NOTE:2
THRESHOLD PROFILE,
WIDTH & HEIGHT VARIES
WITH MANUFACTURER.
- NOTE:3 APPLIED
ATTACHMENT FLANGE
NOT CONSIDERED
TO BE WEATHER TIGHT

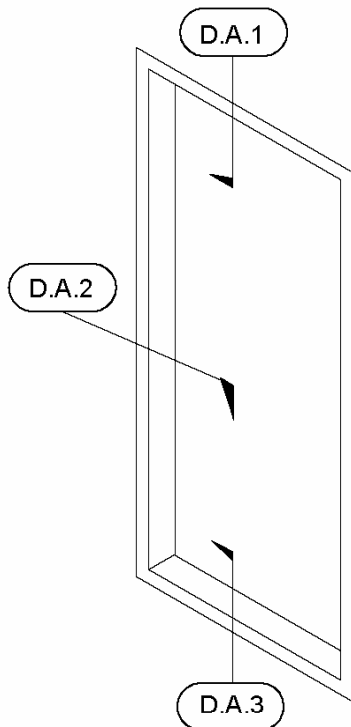

MATERIALS KEY:

- A** BUILDING PAPER - WEATHER-RESISTANT BARRIER (WRB)
- B** SEALANT BEAD
- C** DOOR FRAME
- D** WALL SHEATHING
- E** EXTERIOR WALL CLADDING
- F** SUPPLEMENTAL HEAD FLASHING
- G** THRESHOLD (SILL PAN) FLASHING

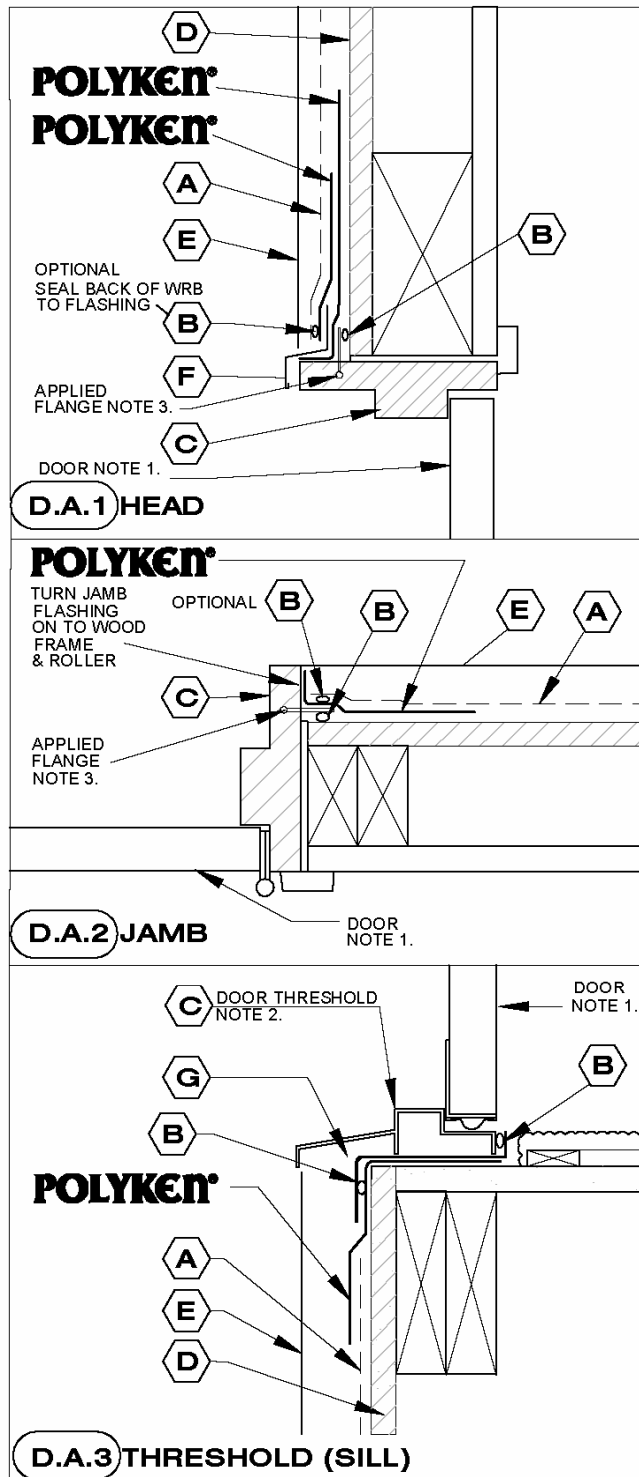

DOOR FLASHING - METHOD A1 (HOUSEWRAP)

NOTE:1
DOOR CAN BE INSWING,
OUT SWING OR SLIDER.

NOTE:2
THRESHOLD PROFILE,
WIDTH & HEIGHT VARIES
WITH MANUFACTURER.

NOTE:3 APPLIED
ATTACHMENT FLANGE
NOT CONSIDERED
TO BE WEATHER TIGHT

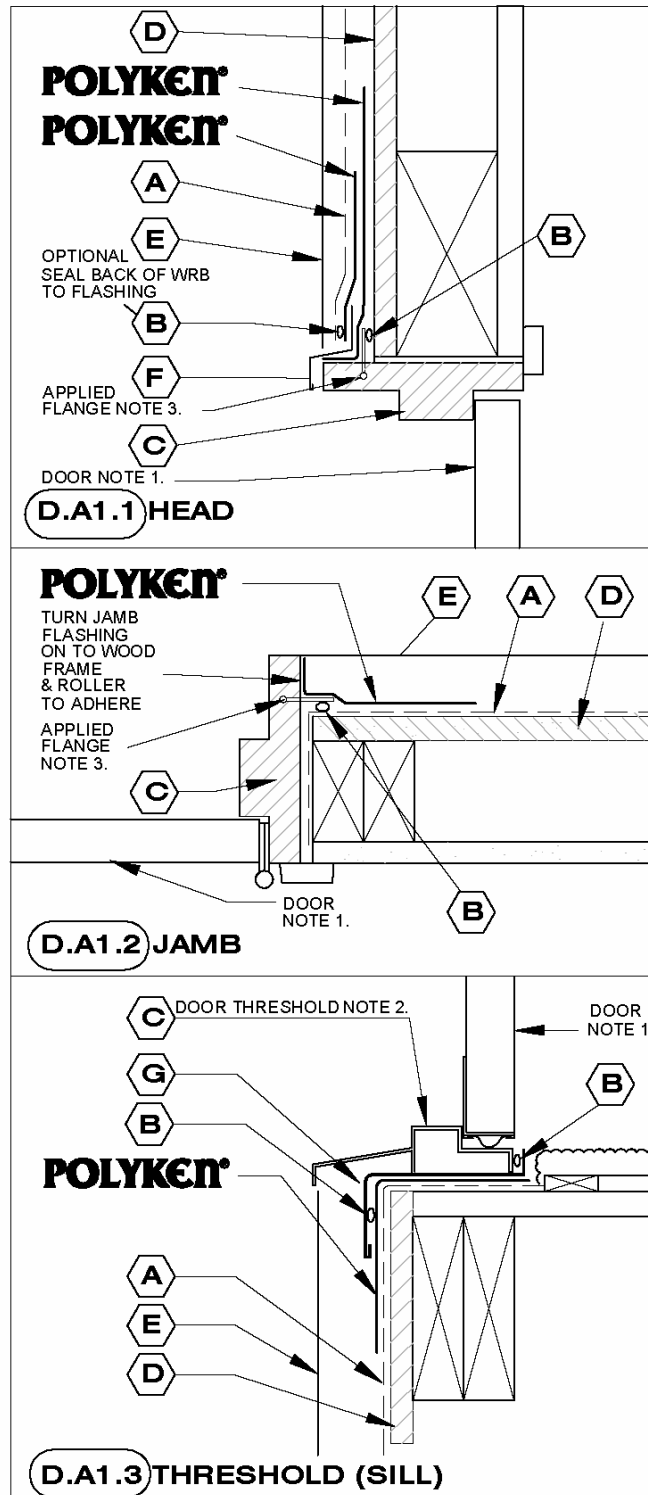
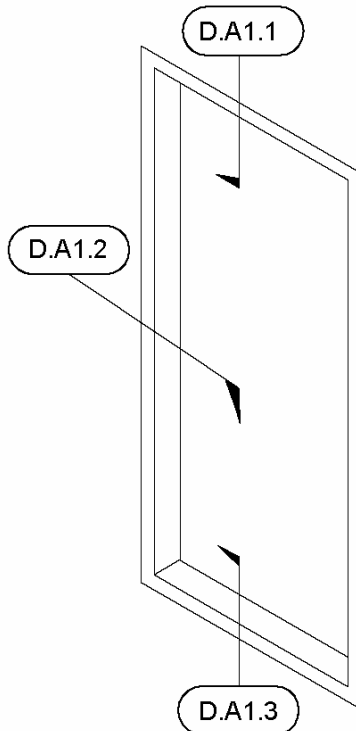

MATERIALS KEY:

- A** HOUSE WRAP WEATHER-RESISTANT BARRIER (WRB)
- B** SEALANT BEAD
- C** DOOR FRAME
- D** WALL SHEATHING
- E** EXTERIOR WALL CLADDING
- F** SUPPLEMENTAL HEAD FLASHING
- G** THRESHOLD (SILL PAN) FLASHING

DOOR FLASHING - METHOD SAF (BUILDING PAPER)

NOTE:1
DOOR CAN BE INSWING,
OUT SWING OR SLIDER.

NOTE:2
THRESHOLD PROFILE
WIDTH & HEIGHT VARIES
WITH MANUFACTURER.

NOTE:3 APPLIED
ATTACHMENT FLANGE
NOT CONSIDERED
TO BE WEATHER TIGHT

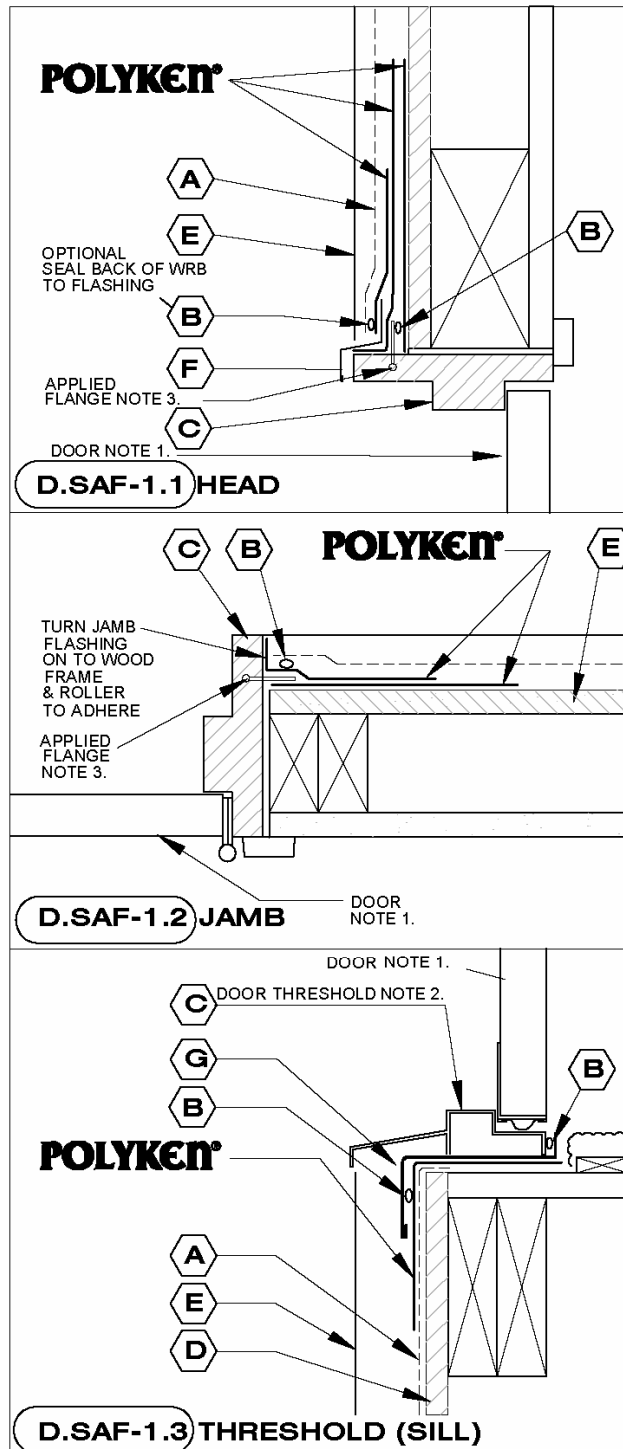
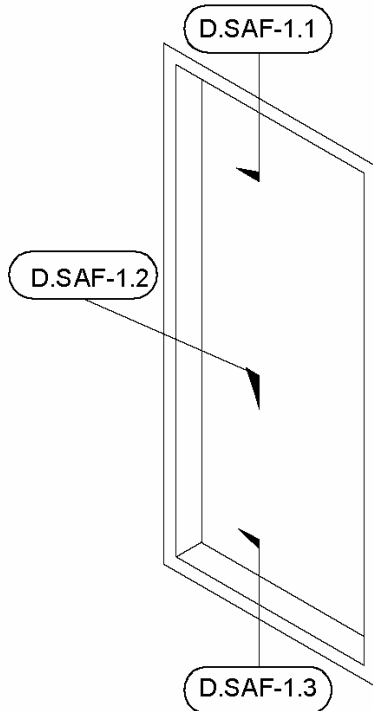

MATERIALS KEY:

- A** BUILDING PAPER - WEATHER-RESISTANT BARRIER (WRB)
- B** SEALANT BEAD
- C** DOOR FRAME
- D** WALL SHEATHING
- E** EXTERIOR WALL CLADDING
- F** SUPPLEMENTAL HEAD FLASHING
- G** THRESHOLD (SILL PAN) FLASHING

DOOR FLASHING - METHOD SAF (HOUSEWRAP)

NOTE:1
DOOR CAN BE IN SWING,
OUT SWING OR SLIDER.

NOTE:2
THRESHOLD PROFILE,
WIDTH & HEIGHT VARIES
WITH MANUFACTURER.

NOTE:3 APPLIED
ATTACHMENT FLANGE
NOT CONSIDERED
TO BE WEATHER TIGHT

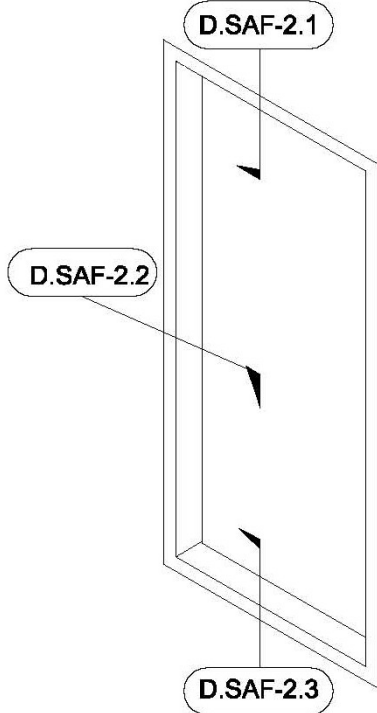

MATERIALS KEY:

- A** HOUSEWRAP - WEATHER-RESISTANT BARRIER (WRB)
- B** SEALANT BEAD
- C** DOOR FRAME
- D** WALL SHEATHING
- E** EXTERIOR WALL CLADDING
- F** SUPPLEMENTAL HEAD FLASHING
- G** THRESHOLD (SILL PAN) FLASHING

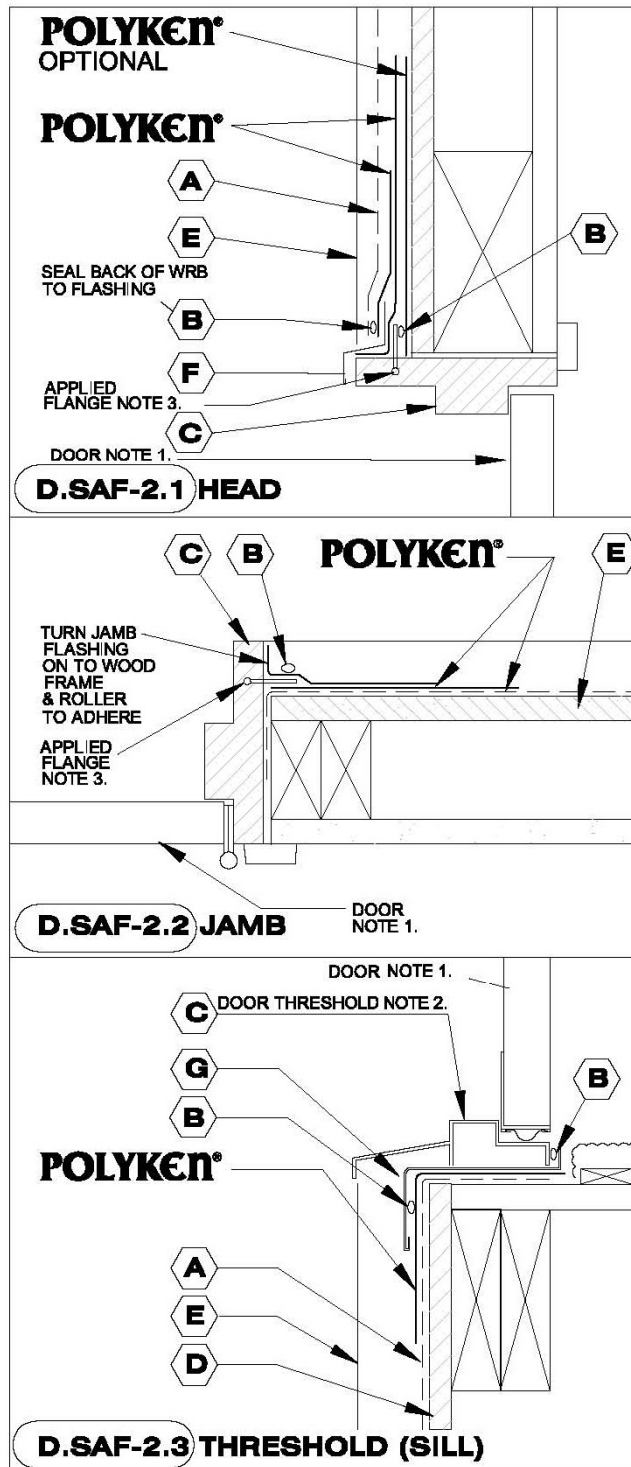

**TYPE 1 FLUSH MOUNT & TYPE 3 INTEGRAL CURB SKYLIGHT FLASHING
METHOD SP-1/3**

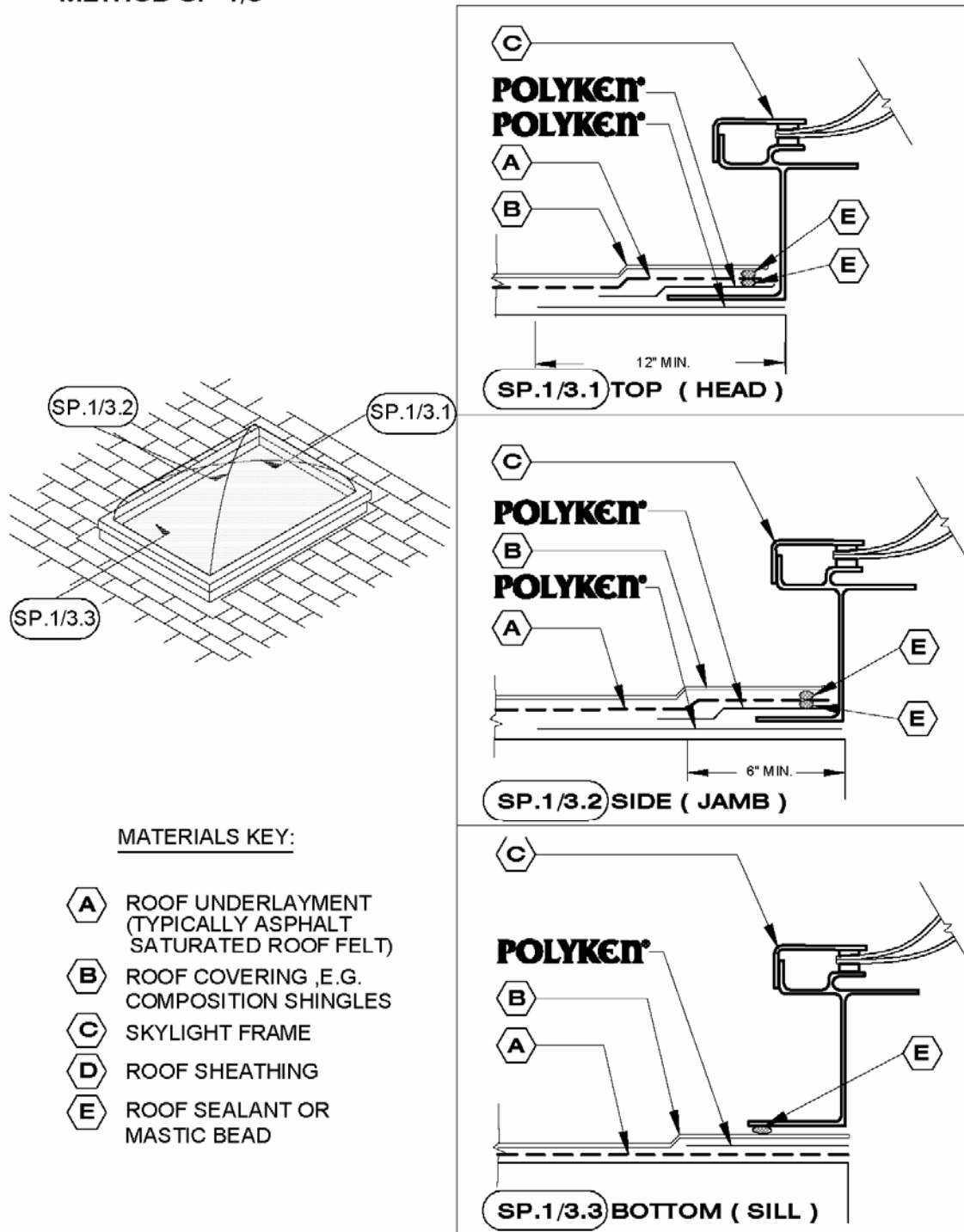

TYPE 2 DECK MOUNT & TYPE 4 INSET MOUNT SKYLIGHT FLASHING METHOD SP-2/4

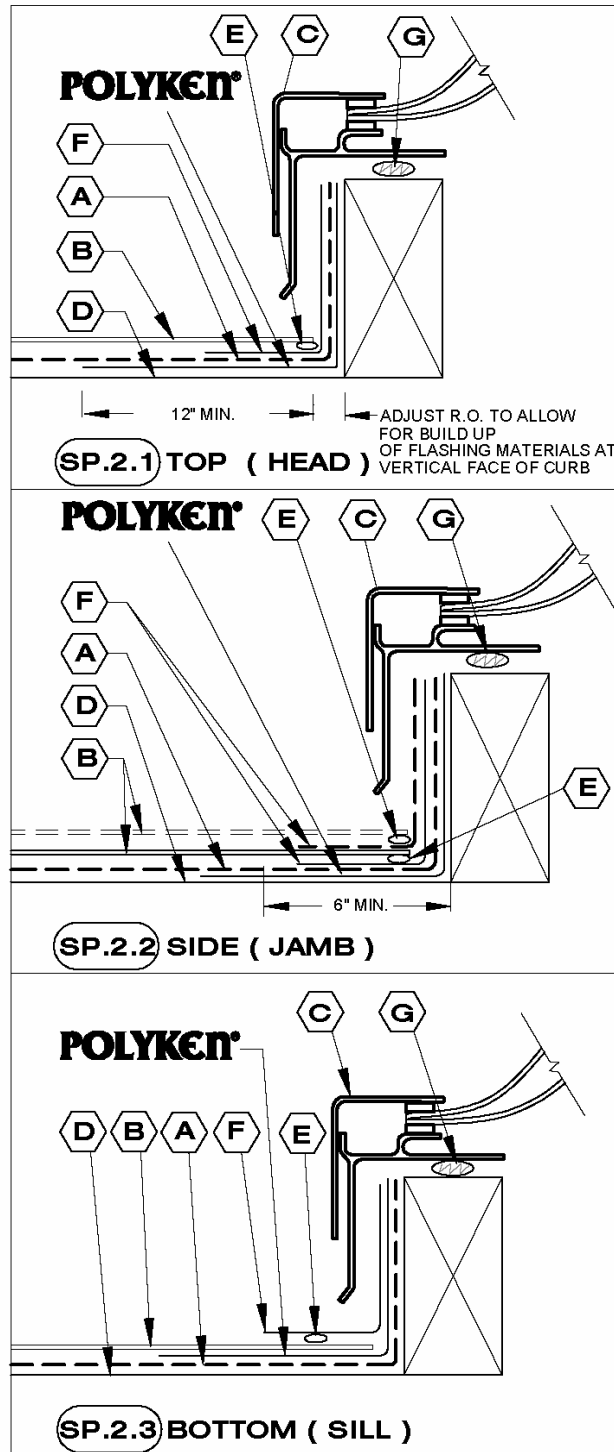
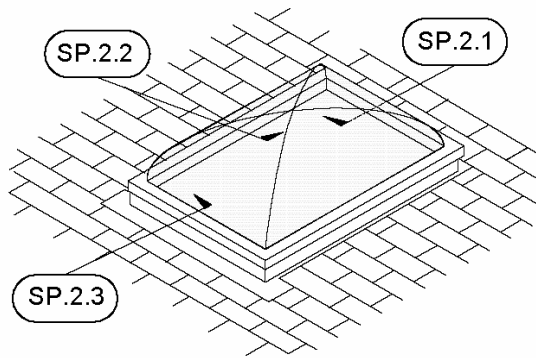

MATERIALS KEY:

- A** ROOF UNDERLAYMENT (TYPICALLY ASPHALT SATURATED ROOF FELT)
- B** ROOF COVERING ,E.G. COMPOSITION SHINGLES
- C** SKYLIGHT FRAME
- D** ROOF SHEATHING
- E** ROOF MASTIC BEAD
- F** SHEET METAL FLASHING
- G** SEALANT OR SEALANT/ FOAM TAPE

Window Flashing Application – Method A

The following diagrams illustrate window flashing installation procedures according to Method A from ASTM E2112-07 Standard Practice for Installation of Exterior Windows,

Doors and Skylights using Polyken® and Nashua® Flashing Tapes. Method A is jamb flashing applied over the window frame using typical building paper. Figure 1 is an exploded view showing the flashing sequence.

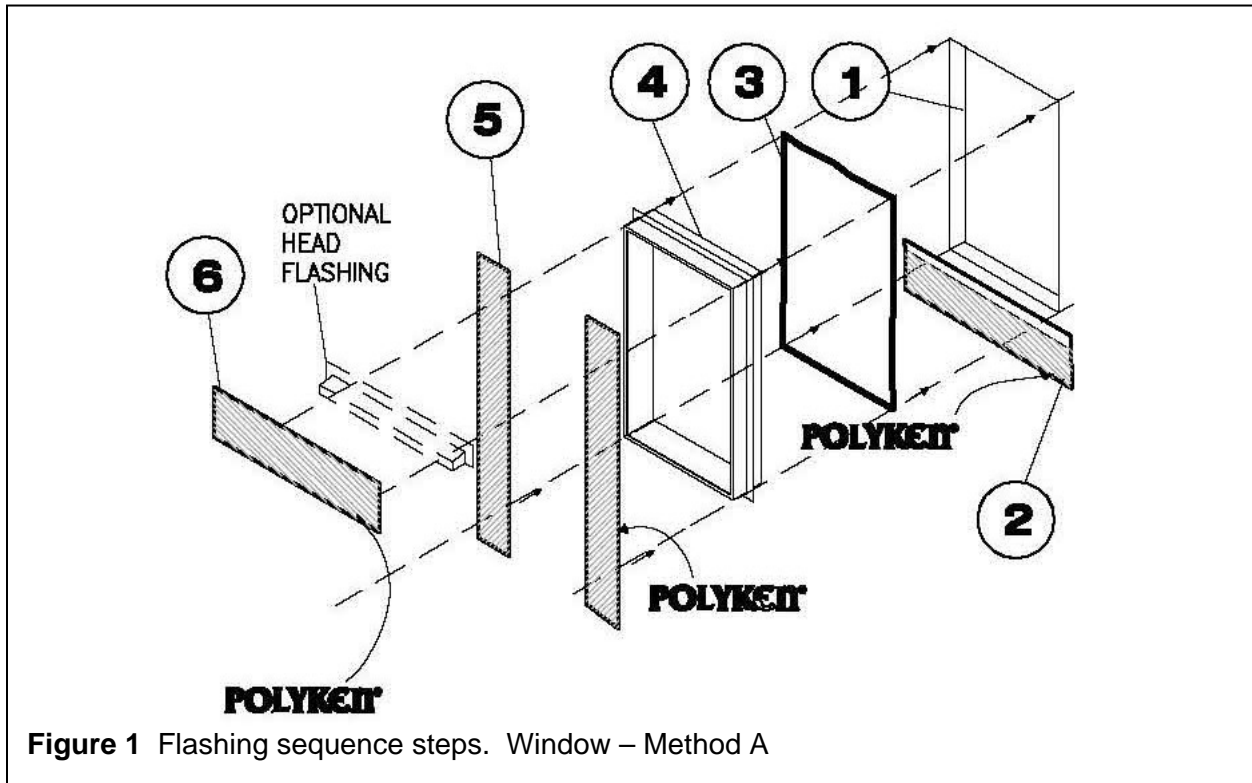

Step 1. Prepare opening and surrounding substrate. Keep substrate surface clean, dry, and smooth around the perimeter (see Figure 2).

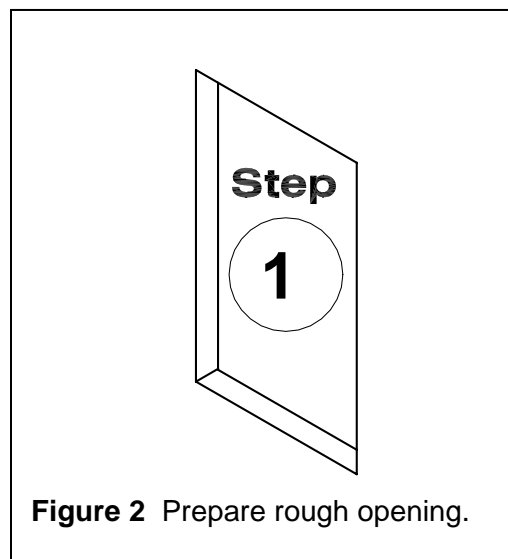

Step 2. Precut length of Polyken® or Nashua® sill flashing tape to extend a minimum of 6" beyond the rough opening at both jambs. (See Options below.)

Score the backside of Polyken® or Nashua® sill flashing, cutting lightly through release liner a few inches from top edge to act as a substrate adhering edge. Keep bottom portion of release liner on the Polyken® or Nashua® sill flashing until removed later. Apply Polyken® or Nashua® sill flashing tape across the rough opening of the sill (see Figure 3).

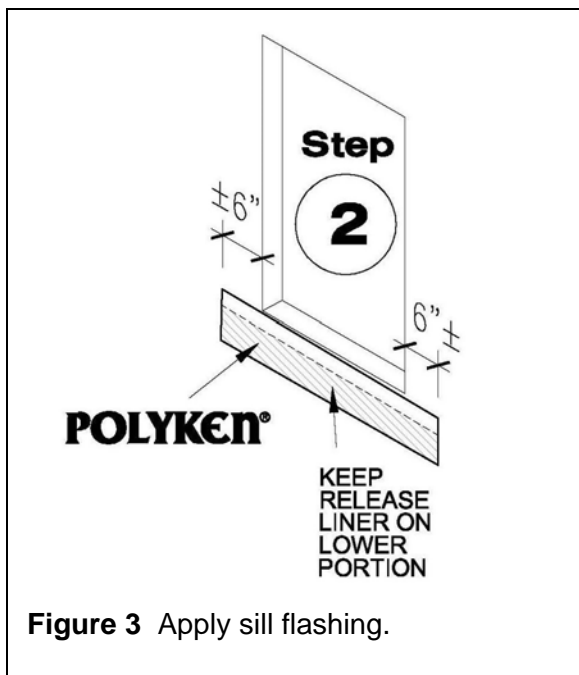

Figure 3 Apply sill flashing.

Options:

1. Apply split sheet of weather-resistant barrier (WRB) across sill. Then apply Polyken® or Nashua® sill flashing tape over the WRB.
2. Straight flashing tape can be omitted with the use of flexible Nashua® Contour 697-40 flashing tape (see other details available in Section 7.0 of this Manual).

Step 3. Apply sealant around perimeter opening or to backside of window fin at top, sides, and bottom (see Figure 4).

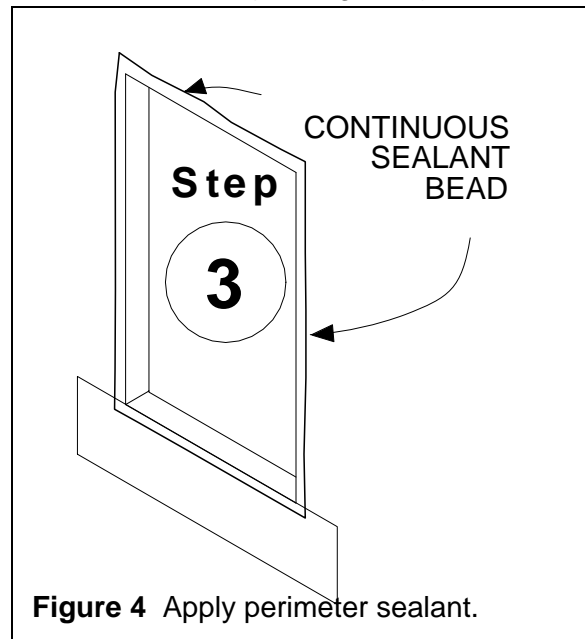

Figure 4 Apply perimeter sealant.

Step 4. Install window in opening (see Figure 5).

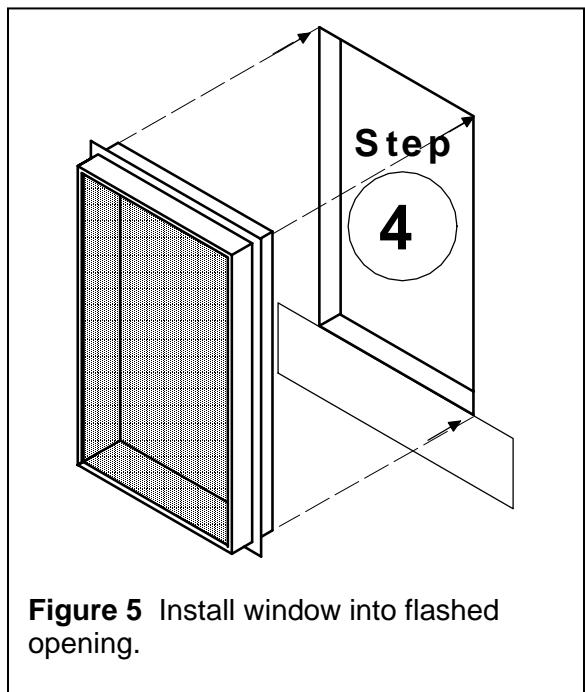

Figure 5 Install window into flashed opening.

Step 5. Precut Polyken® or Nashua® jamb flashing tape to extend a minimum of 6” above and below the rough opening. Peel off release liner and adhere Polyken® or Nashua® jamb flashing over the jamb fins and over top of Polyken® or Nashua® sill flashing (see Figure 6).

Step 6. Precut Polyken® or Nashua® head flashing tape to extend a minimum of 6” beyond the jambs of the rough opening. Peel off release liner and adhere Polyken® or Nashua® head flashing over window fin and substrate. Install supplemental head flashing (where occurs) with a strip of Polyken® or Nashua® flashing over the top leg

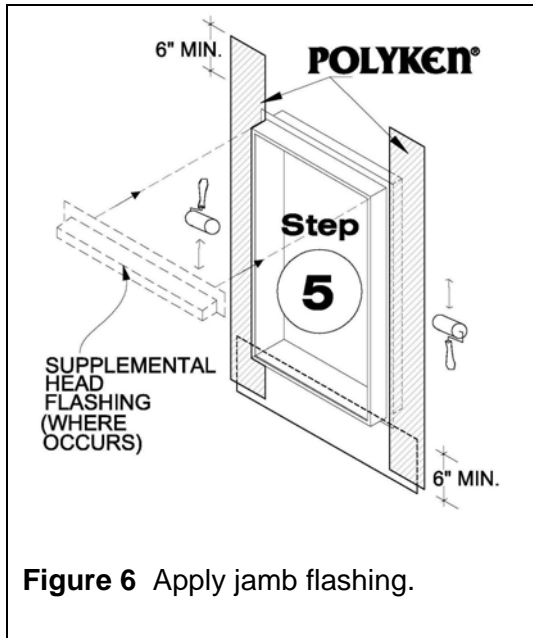

Figure 6 Apply jamb flashing.

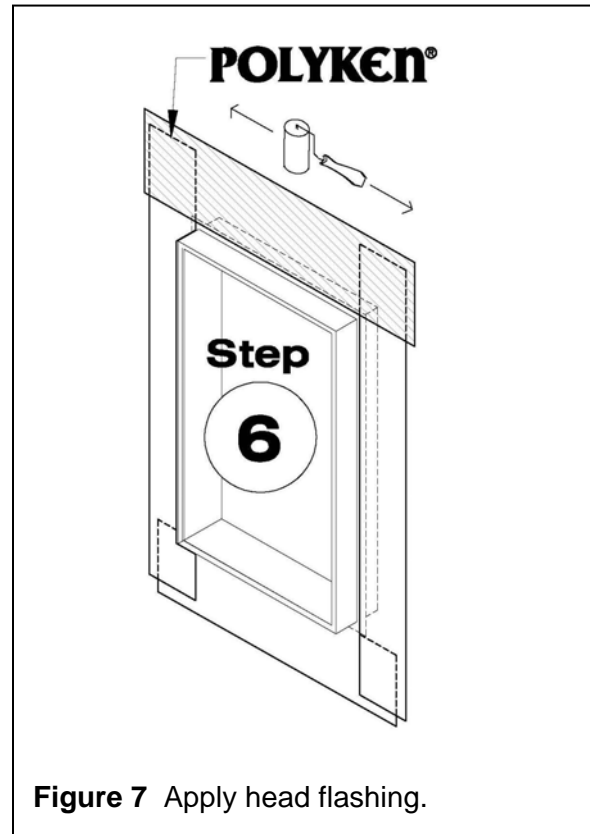

Figure 7 Apply head flashing.

Step 7. Install weather-resistant barrier (WRB) shingle fashion from bottom of wall to top. Insert WRB under Polyken® or Nashua® sill flashing.

Peel off remaining release liner from Polyken® or Nashua® sill flashing and adhere to WRB. Seal edges of WRB to Polyken® or Nashua® flashing along the window jamb and head (see Figure 8).

Step 8. Install trim and/or exterior wall cladding around perimeter of window. Seal perimeter joints per the recommendations of the cladding and window manufacturers (see Figure 9).

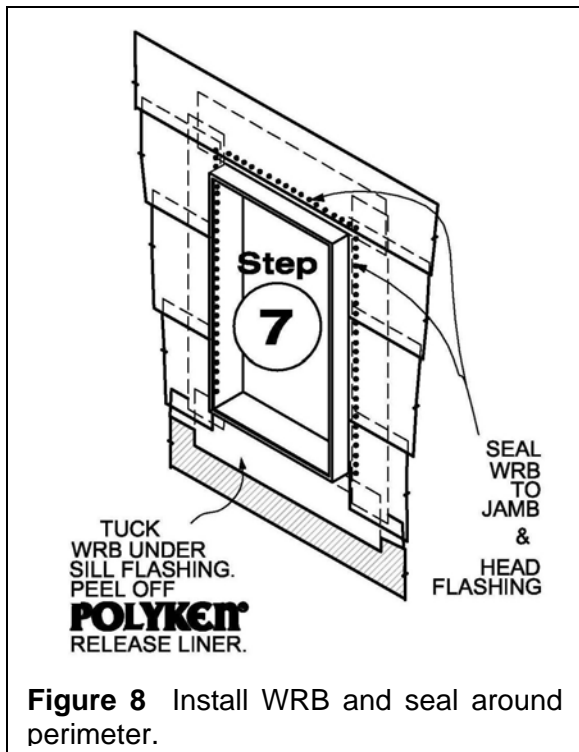
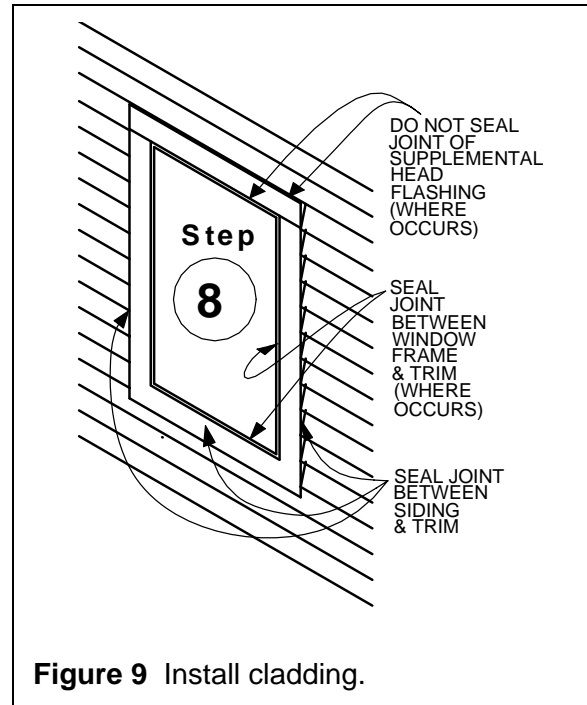

Figure 8 Install WRB and seal around perimeter.



Notice: The final determination of the sealing of joints between cladding, trim, and frame is not the responsibility of Covalence Adhesives.

Window Flashing Application – Method A1

The following diagrams illustrate window flashing installation procedures according to Method A1 from ASTM E 2112-07 Standard Practice for Installation of Exterior Windows,

Doors and Skylights using Polyken® or Nashua® Flashing Tapes. Method A1 is jamb flashing applied over the window frame with house wrap applied under the window frame. Figure 1 is an exploded view showing the flashing sequence.

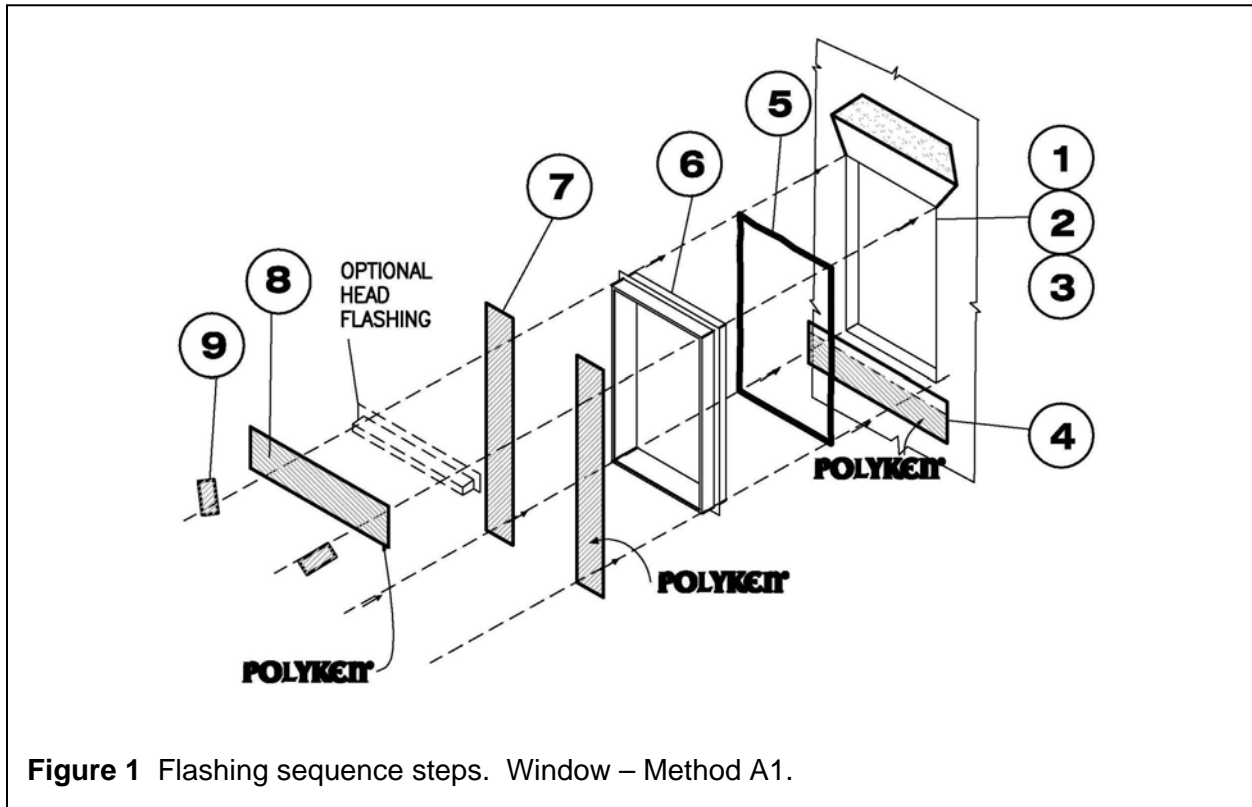

Figure 1 Flashing sequence steps. Window – Method A1.

Step 1. Prepare opening and surrounding substrate. Keep substrate surface clean, dry, and smooth around perimeter (see Figure 2).

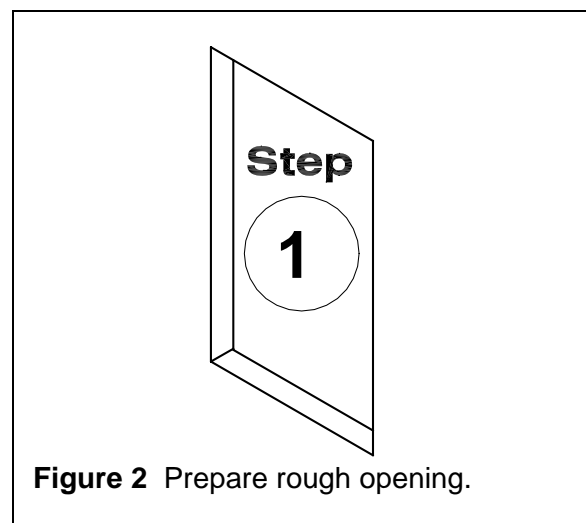
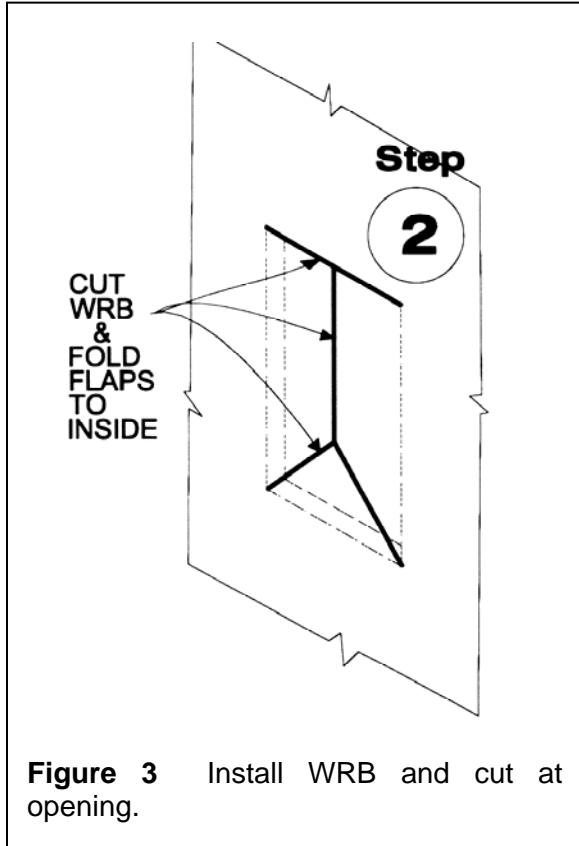
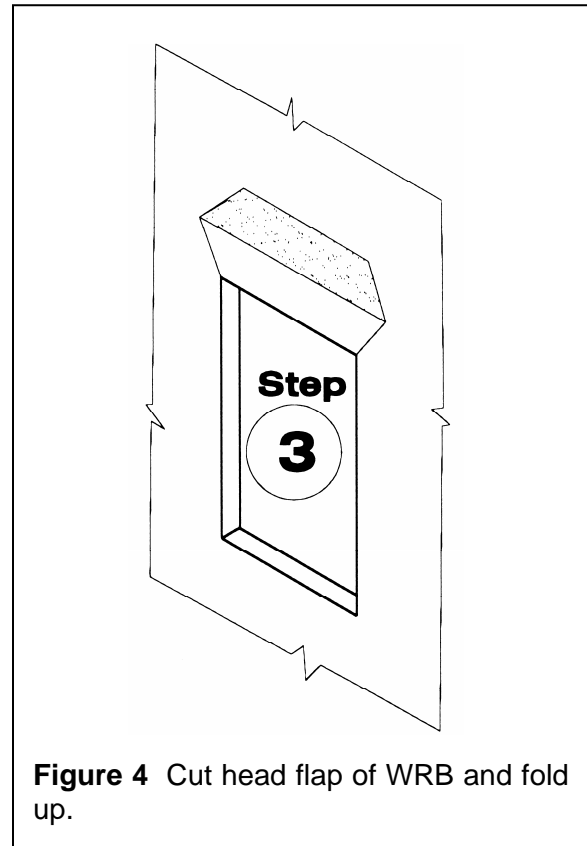

Figure 2 Prepare rough opening.

Step 2. Apply the continuous weather-resistant barrier (WRB – e.g., house wrap) across opening. Cut WRB at opening in modified T-pattern. Fold WRB into opening at sides and bottom (see Figure 3).



Step 3. Cut diagonal slits from top of opening corners through WRB a distance equal to just more than the width of jamb/head flashing tape used. Fold flap of WRB above opening head and temporarily tape in place (see Figure 4).



Step 4. Precut length of sill flashing to extend beyond rough opening on each side and beyond width of jamb flashings. Adhere Polyken® or Nashua® membrane over WRB across sill (see Figure 5).

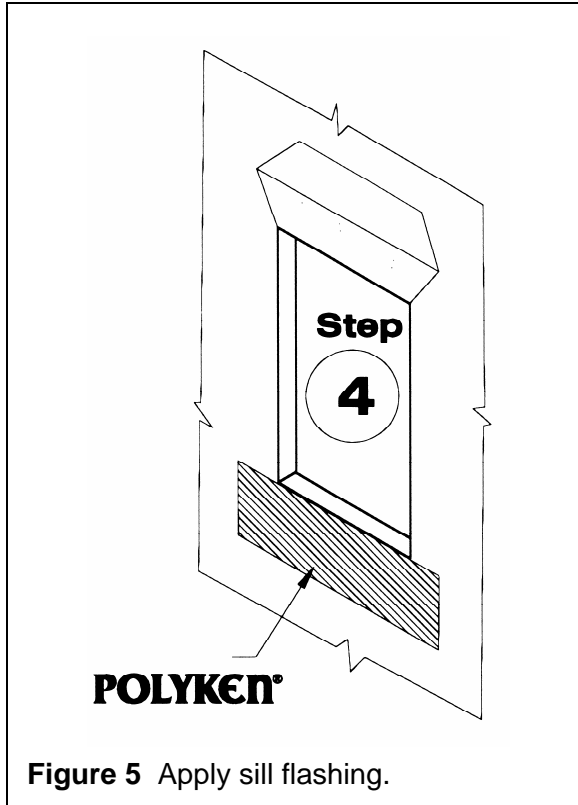

Step 5. Apply seal around perimeter opening or to backside of window fin (see Figure 6).

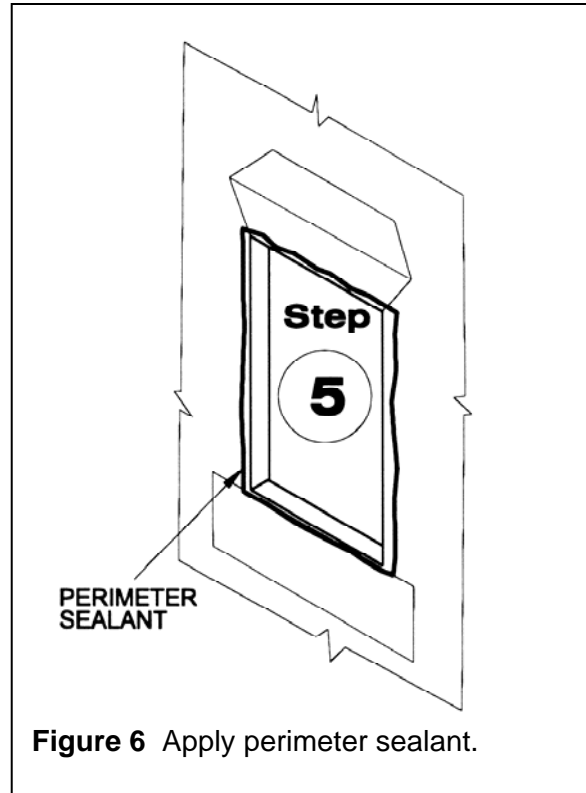

Step 6. Install window in opening (see Figure 7).

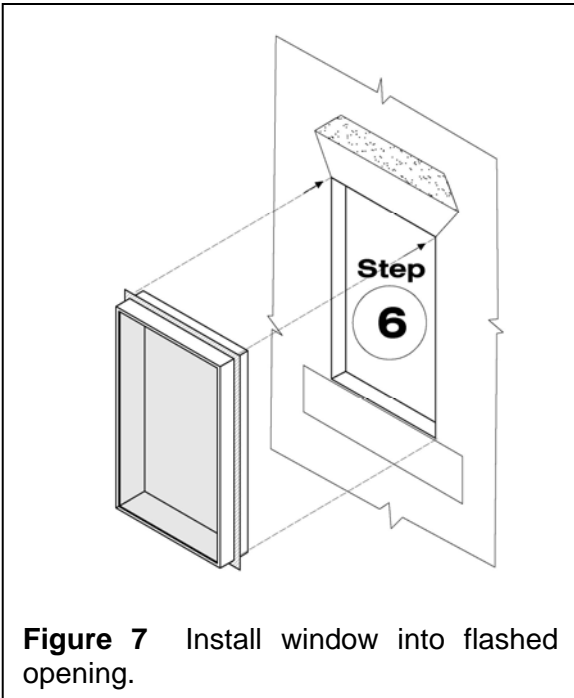

Figure 7 Install window into flashed opening.

Step 7. Precut Polyken® or Nashua® jamb flashing tape to extend a minimum of 6” above and below the rough opening. Peel off release liner and adhere Polyken® or Nashua® jamb flashing over the jamb fins and over top of Polyken® or Nashua® sill flashing (see Figure 8).

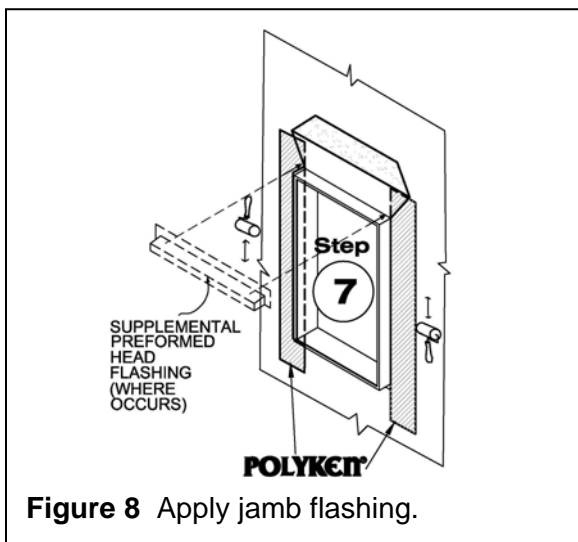

Figure 8 Apply jamb flashing.

Step 8. Precut Polyken® or Nashua® head flashing tape to extend a minimum of 6” beyond the jambs of the rough opening. Peel off release liner and adhere Polyken® or Nashua® head flashing over window fin and substrate. Install supplemental head flashing (where occurs) with a strip of Polyken® or Nashua® flashing over the top leg (see Figure 9).

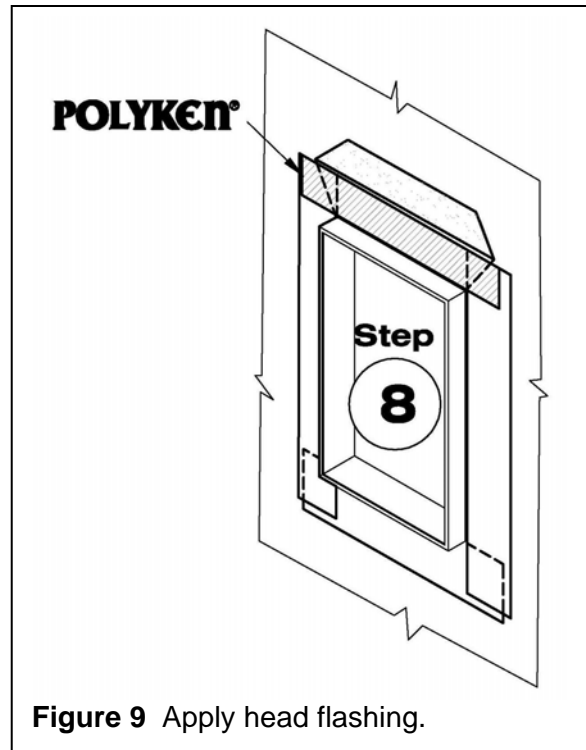

Figure 9 Apply head flashing.

Step 9. Fold down flap of WRB at head over Polyken® or Nashua® head flashing tape. Seal bottom of WRB flap along full length of window head. Install WRB sheathing tape or Polyken® or Nashua® flashing tape over diagonal cuts (see Figure 10).

Step 10. Install trim and/or exterior wall cladding around perimeter of window. Seal perimeter joints per the recommendations of the cladding and window manufacturers (see Figure 11).

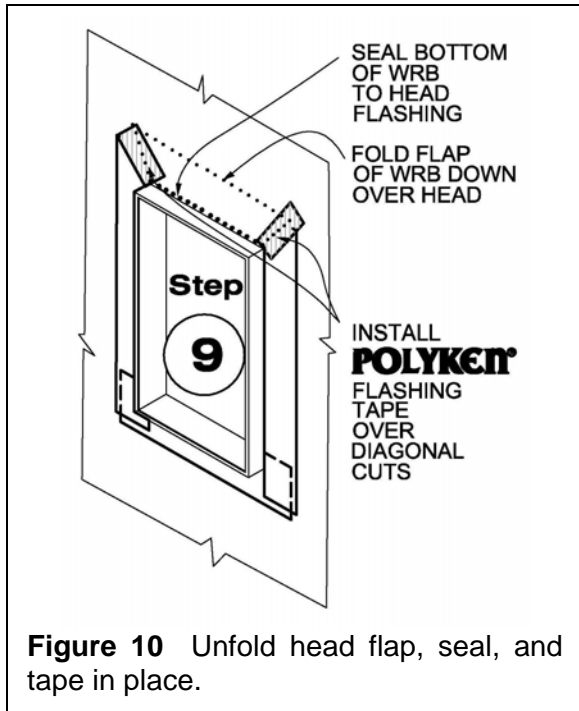

Figure 10 Unfold head flap, seal, and tape in place.

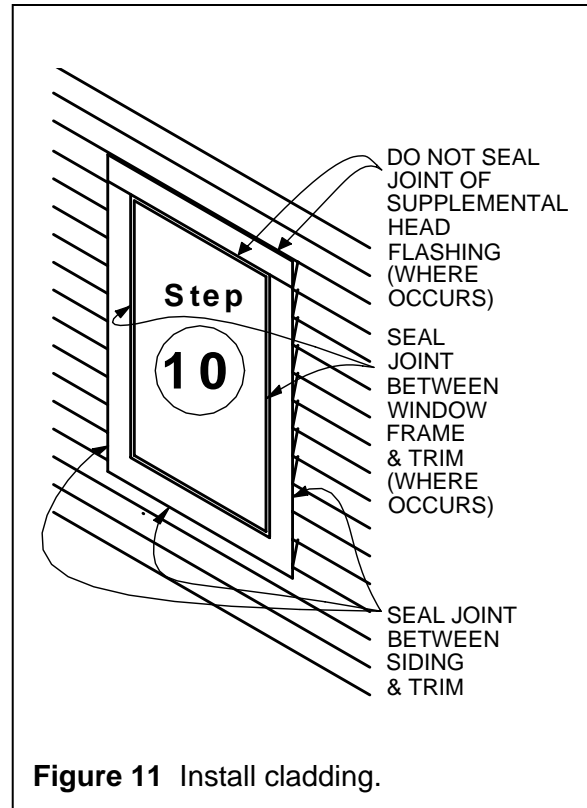

Figure 11 Install cladding.

Notice: The final determination of the sealing of joints between cladding, trim, and frame is not the responsibility of Berry Plastics.

Window Flashing Application – Method SAF

The following diagrams illustrate window flashing installation procedures that modify the methods described in ASTM E2112-07 Standard Practice for Installation of Exterior Windows, Doors and Skylights. This method combines features of ASTM Method

A and Method B flashing under and over the fin of the frame. A strip of Polyken® or Nashua® Flashing Tape is substituted for the bead of perimeter sealant applied under the window fins in the ASTM methods. Figure 1 is an exploded view showing the flashing sequence. The method name, “SAF”, stands for Self Adhering Flashing.

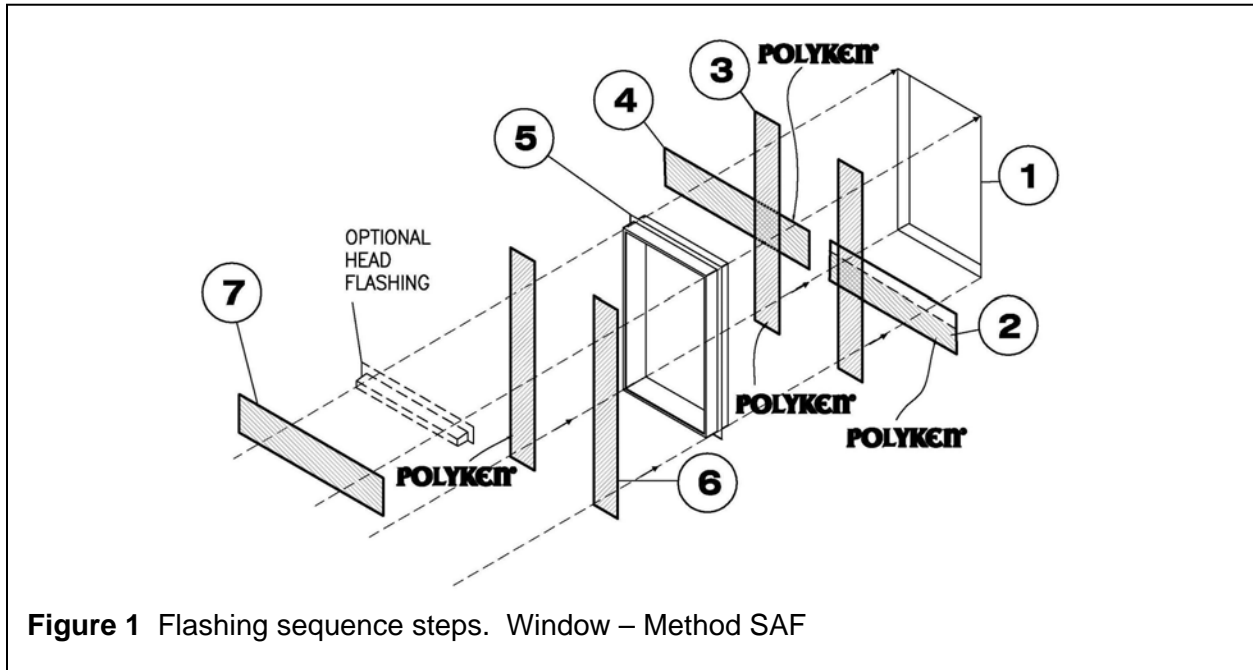

Figure 1 Flashing sequence steps. Window – Method SAF

Step 1. Prepare opening and surrounding substrate. Keep substrate surface clean, dry, and smooth around the perimeter (see Figure 2).

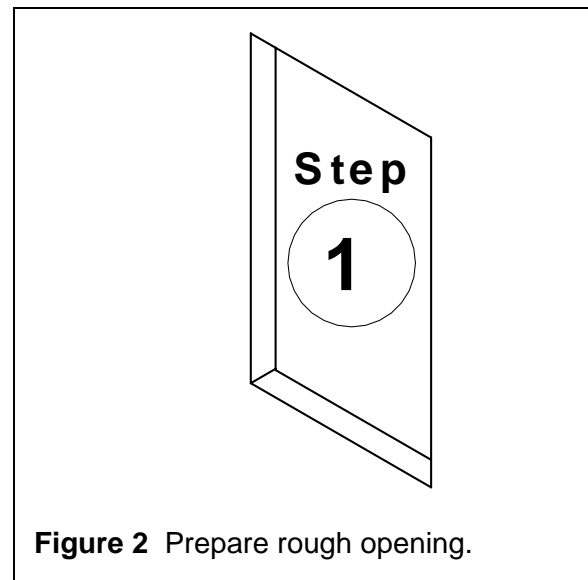

Figure 2 Prepare rough opening.

Step 2. Precut length of Polyken® or Nashua® sill flashing tape to extend a minimum of 6" beyond the rough opening at both jambs.

Score the backside of Polyken® or Nashua® sill flashing, cutting lightly through release liner a few inches from top edge to act as a substrate adhering edge. Keep bottom portion of release liner on the Polyken® sill flashing until removed later. Apply Polyken® or Nashua® sill flashing tape across the rough opening of the sill (see Figure 3).

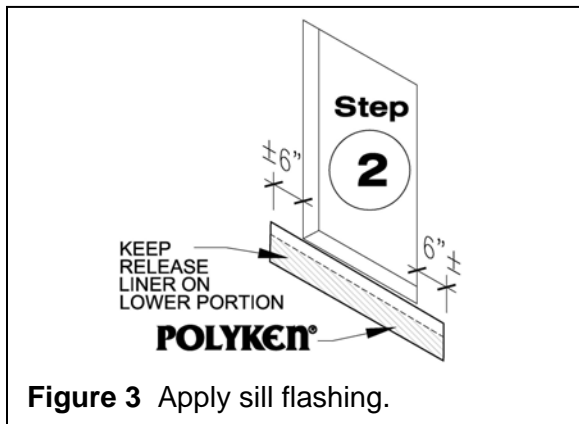

Figure 3 Apply sill flashing.

Step 3. Precut Polyken® or Nashua® jamb flashing tape to extend a minimum of 6" above and below the rough opening. Peel off release liner and adhere Polyken® or Nashua® jamb flashing over the jamb fins and over top of Polyken® or Nashua® sill

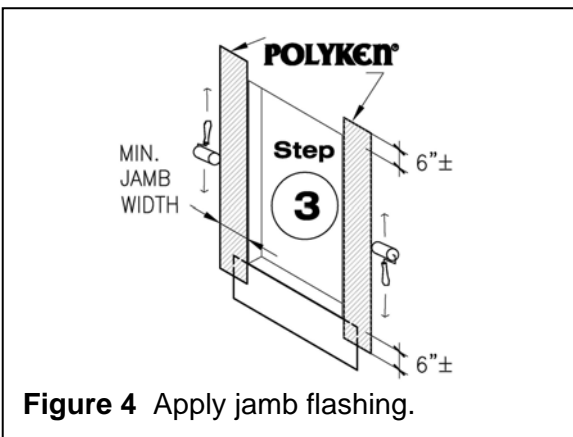

Figure 4 Apply jamb flashing.

flashing (see Figure 4).

Step 4. Precut Polyken® or Nashua® head flashing tape to extend a minimum of 6" beyond the jambs of the rough opening. Peel off release liner and adhere Polyken® or Nashua® head flashing over head opening and jamb flashings (see Figure 5).

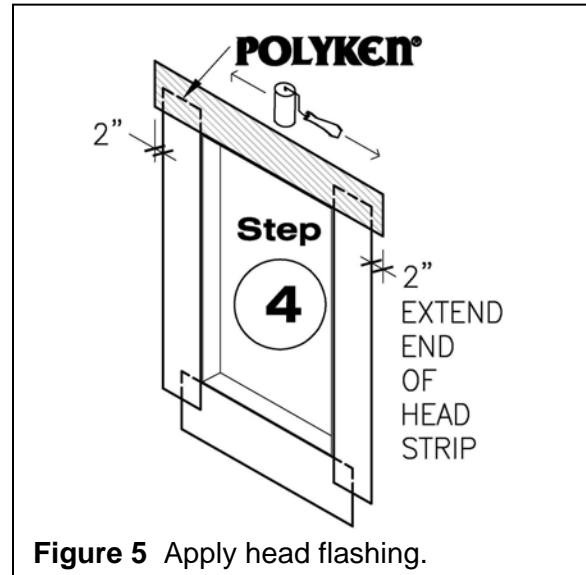

Figure 5 Apply head flashing.

Step 5. Install window in opening (see Figure 6).

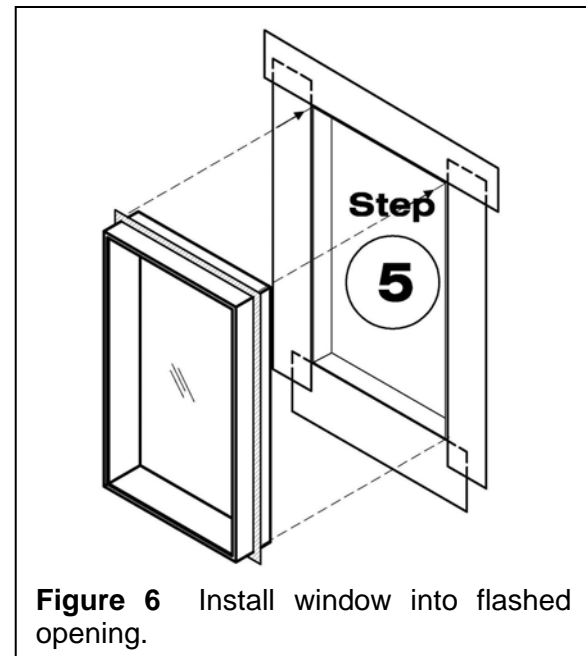

Figure 6 Install window into flashed opening.

Step 6. Precut Polyken® or Nashua® jamb flashing tape to extend a minimum of 6” above and below the rough opening(see Figure 7).

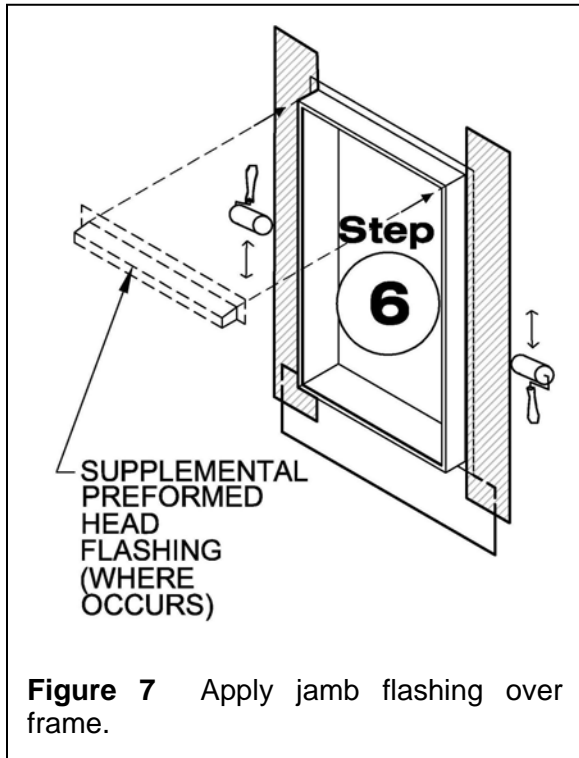

Figure 7 Apply jamb flashing over frame.

Step 7. Precut Polyken® or Nashua® head flashing tape to extend a minimum of 6” beyond the jambs of the rough opening. Peel off release liner and adhere Polyken® or Nashua® membrane over window fin (and optional preformed head flashing) (see Figure 8).

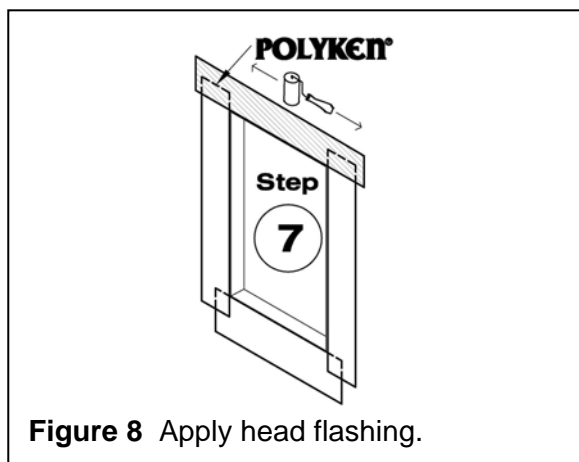

Figure 8 Apply head flashing.

Step 8. Install weather-resistant barrier (WRB) shingle fashion from bottom of wall to top. Integrate sill flashing by inserting WRB under sill flashing. Peel off remaining release liner from Polyken® or Nashua® sill flashing and adhere to WRB. Seal edges of WRB to window jamb and head (see Figure 9).

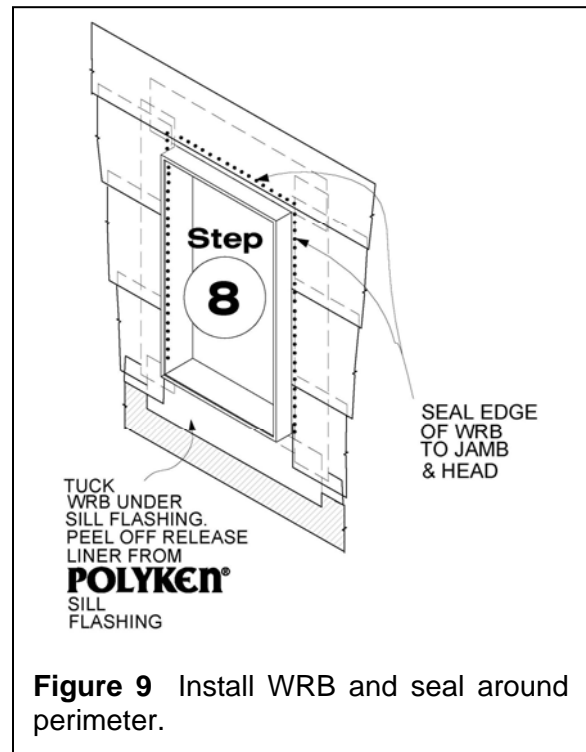

Figure 9 Install WRB and seal around perimeter.

Notice: The final determination of the sealing of joints between cladding, trim, and frame is not the responsibility of Berry Plastics

Step 9. Install trim and/or exterior wall cladding around perimeter of window. Seal perimeter joints per the recommendations of the cladding and window manufacturers (see Figure 10).

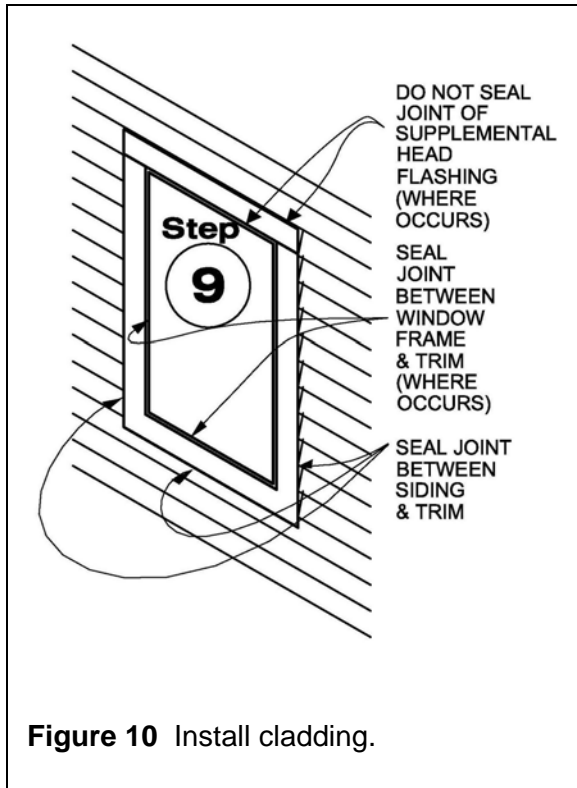

Figure 10 Install cladding.

Door Flashing Application – Method A

The following diagrams illustrate door flashing installation procedures according to Method A from ASTM E2112-07 Standard Practice for Installation of Exterior Windows, Doors and Skylights using Polyken® or

Nashua® Flashing Tapes. Method A is jamb flashing applied over the door frame using typical building paper. Figure 1 is an exploded view showing the flashing sequence.

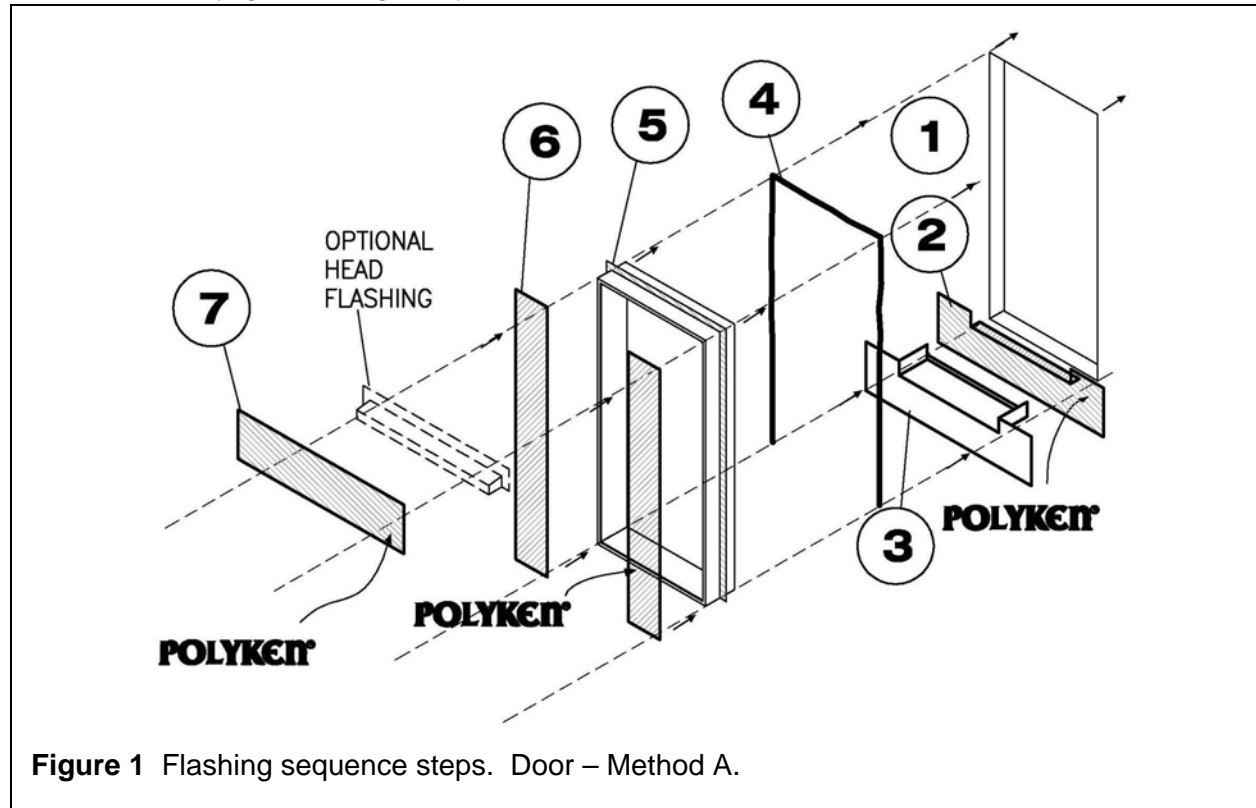

Figure 1 Flashing sequence steps. Door – Method A.

Step 1. Prepare opening and surrounding substrate. Keep substrate surface clean, dry, and smooth around perimeter (see Figure 2).

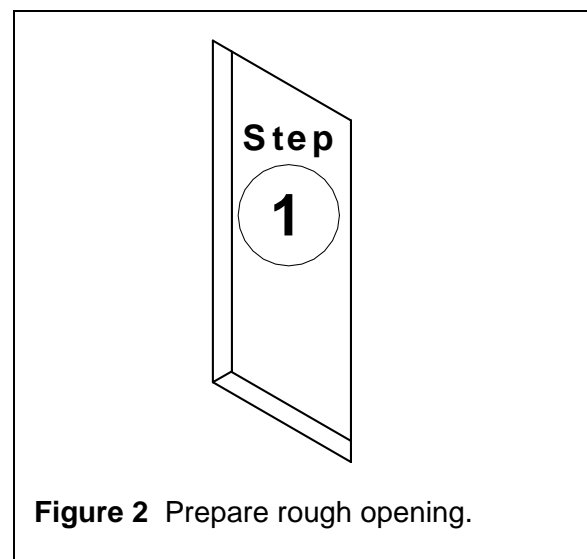

Figure 2 Prepare rough opening.

Step 2. Precut length of Polyken® or Nashua® sill flashing tape to extend a minimum of 6" beyond the rough opening at both jambs. (See Options below.)

Score backside of Polyken® or Nashua® sill flashing cutting lightly through release liner a few inches from top edge to act as a substrate adhering edge. Keep bottom portion of release liner on Polyken® or Nashua® sill flashing until removed later. Apply Polyken® or Nashua® sill flashing tape across rough opening sill (Figure 3).

Step 2a. Apply Polyken® or Nashua® sill flashing tape into the threshold opening. Apply Polyken® or Nashua® circle boots at corners of sill-jamb junctures (see Figure 3).

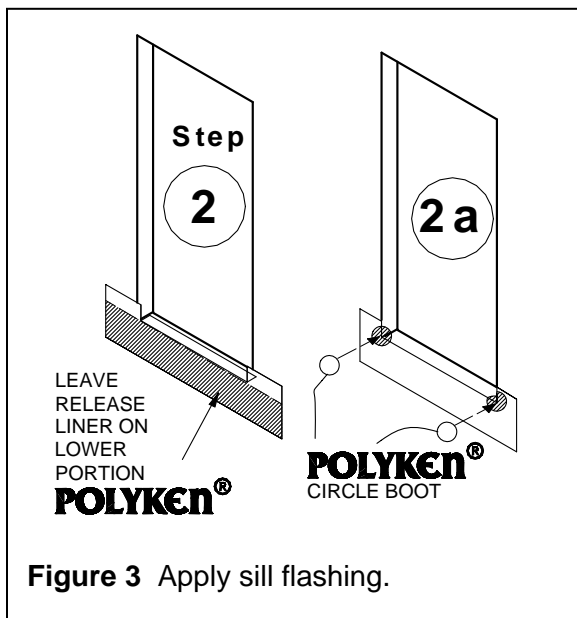

Figure 3 Apply sill flashing.

Options:

1. Apply split sheet of weather-resistant barrier (WRB) across sill. Then apply Polyken® sill flashing tape over WRB.
2. Straight flashing tape can be omitted with the use of Nashua® Contour 697-40 flashing tape (see other details available in Section 7.0 of this Manual).

Step 3. Install preformed threshold (sill) pan over Polyken® or Nashua® sill flashing. Do not fasten pan through horizontal portion of pan (see Figure 4).

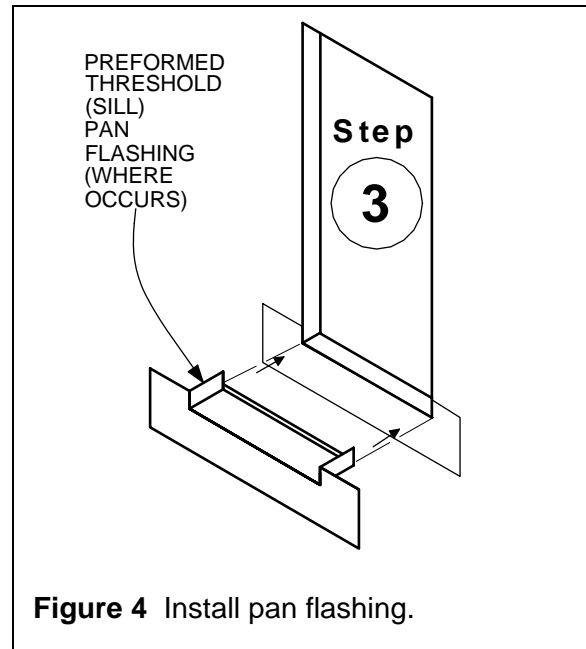

Figure 4 Install pan flashing.

Step 4. Apply seal around perimeter opening or to backside of door fin at top sides. Do not seal along bottom (see Figure 5).

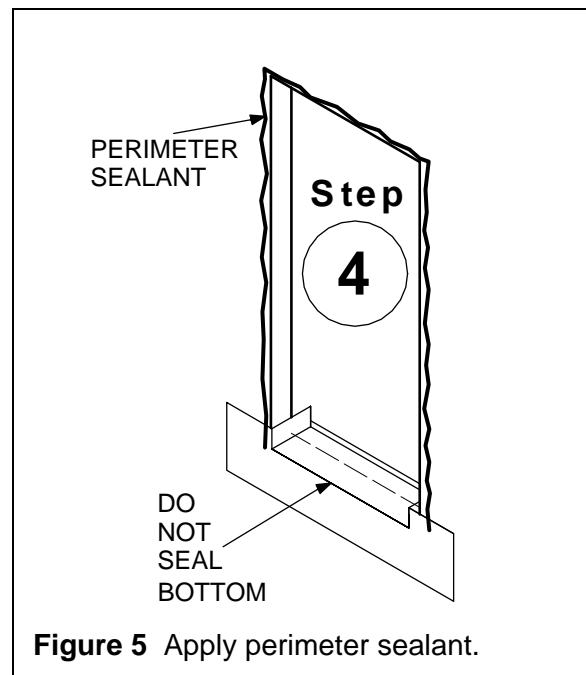

Figure 5 Apply perimeter sealant.

Step 5. Install door into flashed opening (see Figure 6).

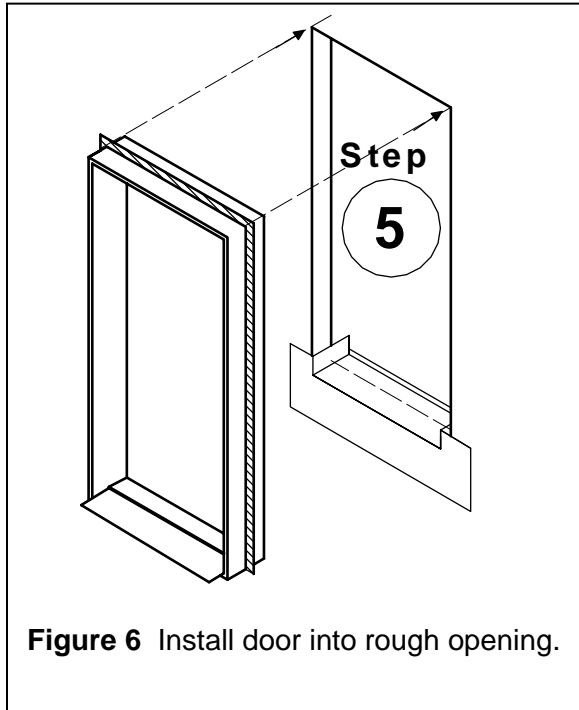

Figure 6 Install door into rough opening.

Step 6. Precut Polyken® or Nashua® jamb flashing tape to extend a minimum of 6" above and below the rough opening. Peel off release liner and adhere membrane over the jamb fins and over top of Polyken® or Nashua® sill flashing tape (see Figure 7). Turn onto frame and refer to General Application Guide, Condition 3.

Step 7. Precut Polyken® or Nashua® head flashing tape to extend a minimum of 6" beyond the jambs of the rough opening. Peel off release liner and adhere membrane over door fin (and over optional preformed head flashing). See Figure 8.

Precut Polyken® or Nashua® head flashing tape to extend beyond the jambs of the rough opening a minimum of 9 in. Peel off release liner and adhere membrane over door fin (and over optional preformed head flashing). See Figure 8. Turn onto frame and refer to General Application Guide, Condition 3.

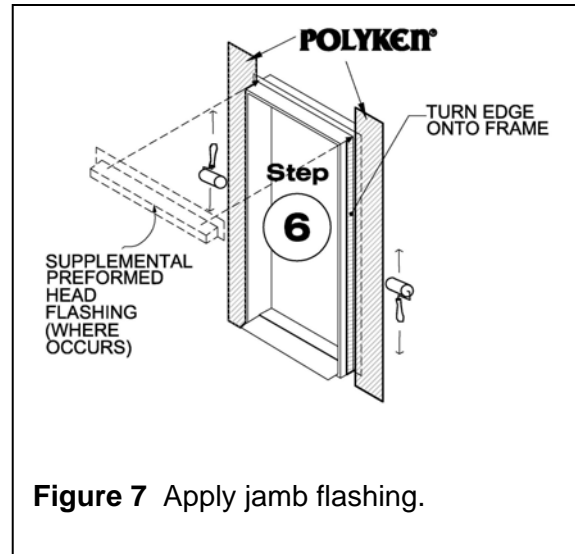

Figure 7 Apply jamb flashing.

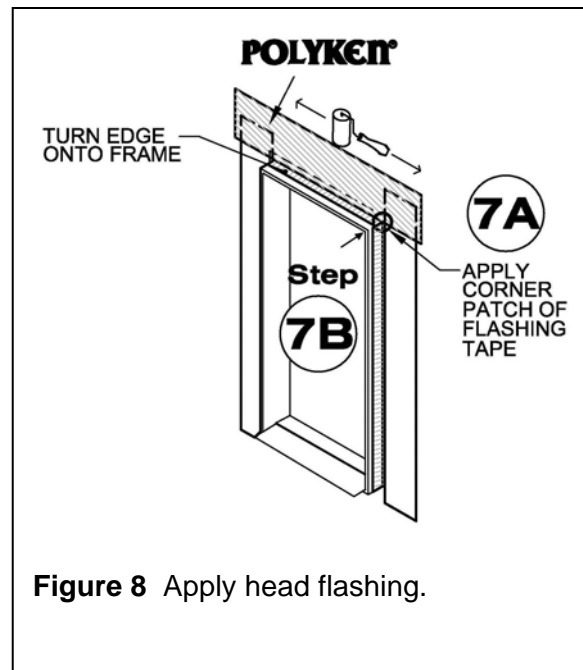

Figure 8 Apply head flashing.

Step 8. Install weather-resistant barrier (WRB) shingle fashion from bottom of wall to top. Insert WRB under Polyken® or Nashua® sill flashing. Peel off remaining release liner from Polyken® or Nashua® sill flashing and adhere to WRB. Seal edges of WRB to Polyken® or Nashua® flashing along the window jamb and head (see Figure 9).

Step 9. Install trim and/or exterior wall cladding around perimeter of window. Seal perimeter joints per the recommendations of the cladding and window manufacturers (see Figure 10).

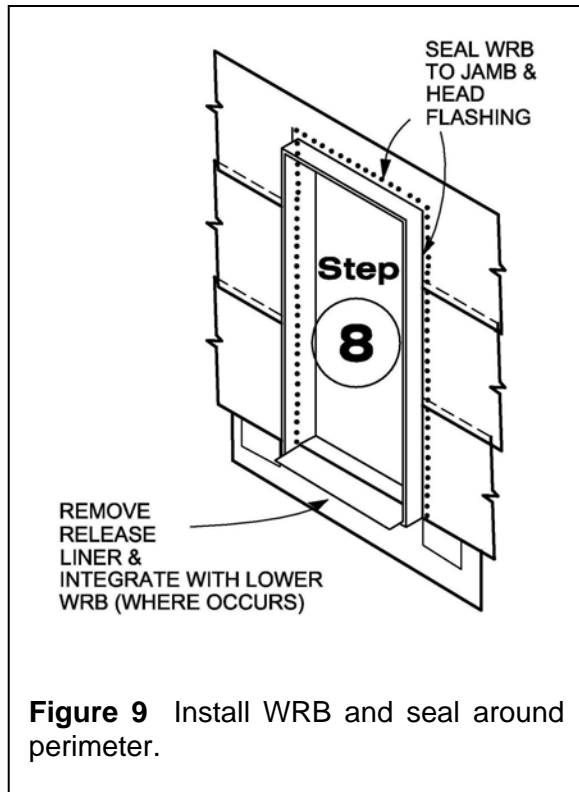

Figure 9 Install WRB and seal around perimeter.

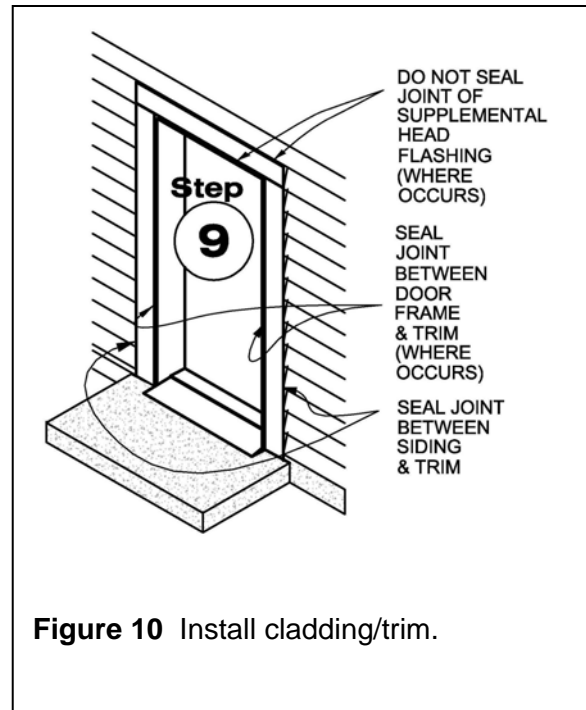

Figure 10 Install cladding/trim.

Notice: The final determination of the sealing of joints between cladding, trim, and frame is not the responsibility of Covalence Adhesives.

Door Flashing Application – Method SAF

The following diagrams illustrate door flashing installation procedures that modify the methods described in ASTM E2112-07 Standard Practice for Installation of Exterior Windows, Doors and Skylights. This method uses combines features of ASTM Method A and Method B flashing under and

over the fin of the frame. A strip of Polyken® or Nashua® Flashing Tape is substituted for the bead of perimeter sealant applied under the door fins in the ASTM methods. Figure 1 is an exploded view showing the flashing sequence. The method name, “SAF”, stands for Self Adhering Flashing.

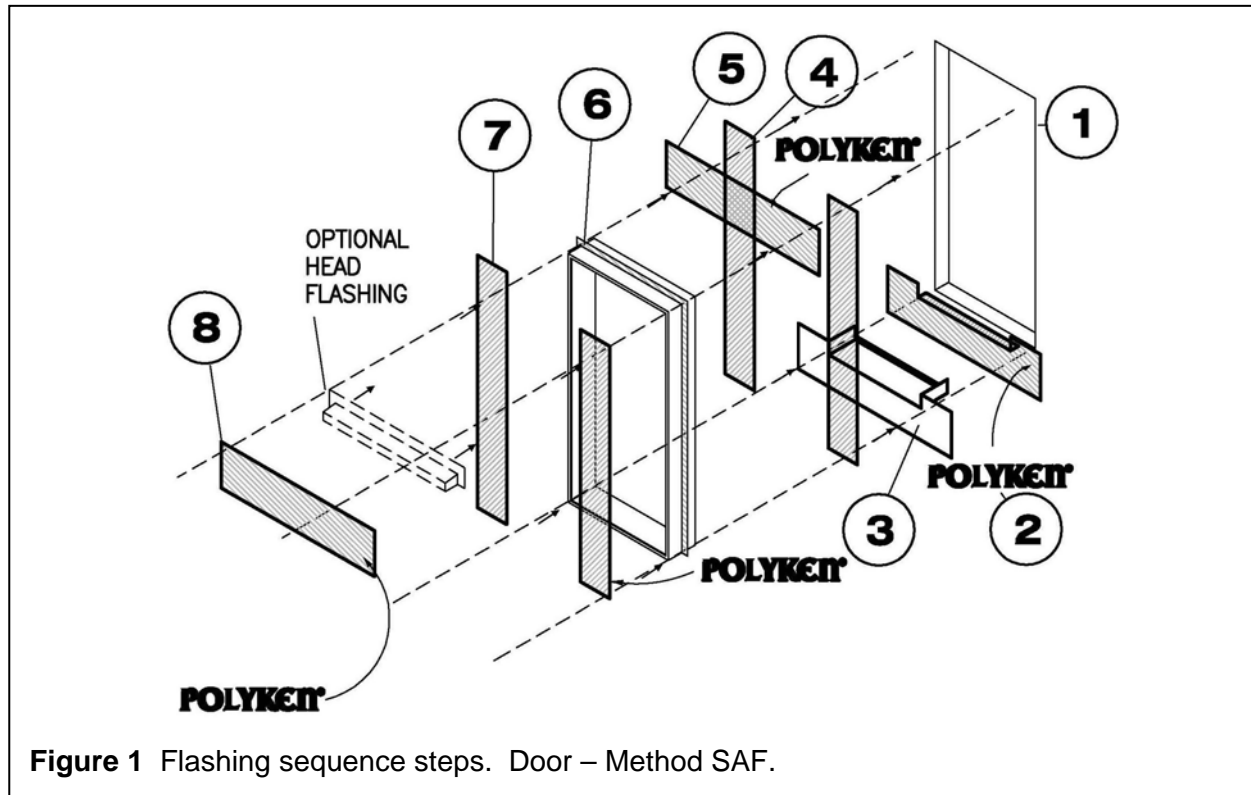

Figure 1 Flashing sequence steps. Door – Method SAF.

Step 1. Prepare opening and surrounding substrate. Keep substrate surface clean, dry, and smooth around the perimeter (see Figure 2).

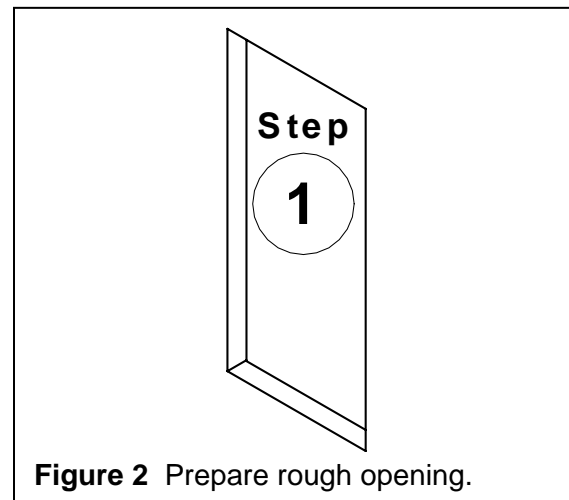

Figure 2 Prepare rough opening.

Step 2. Precut length of Polyken® or Nashua® sill flashing tape to extend a minimum of 6" beyond the rough opening at both jambs.

Score backside of Polyken® or Nashua® sill flashing cutting lightly through release liner a few inches from top edge to act as a substrate adhering edge. Keep bottom portion of release liner on Polyken® or Nashua® sill flashing until removed later. Apply Polyken® or Nashua® sill flashing tape across rough opening sill and into threshold opening(see Figure 3).

Step 2a. Apply Polyken® or Nashua® circle boots at corners of sill-jamb junctures (see Figure 3).

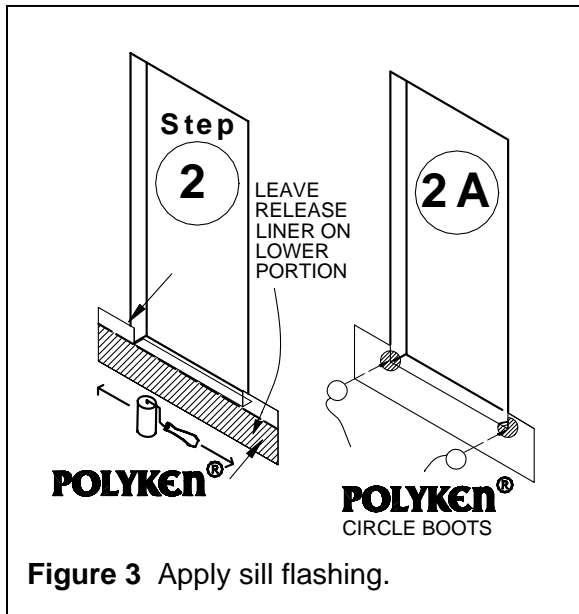

Figure 3 Apply sill flashing.

Step 3. Install preformed threshold (sill) pan over Polyken® or Nashua® sill flashing. Do not fasten pan through horizontal portion of pan. (See Figure 4).

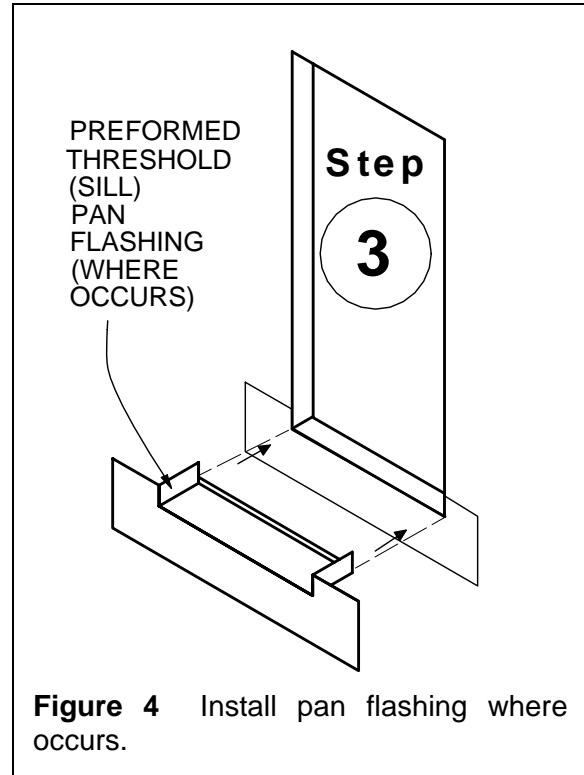
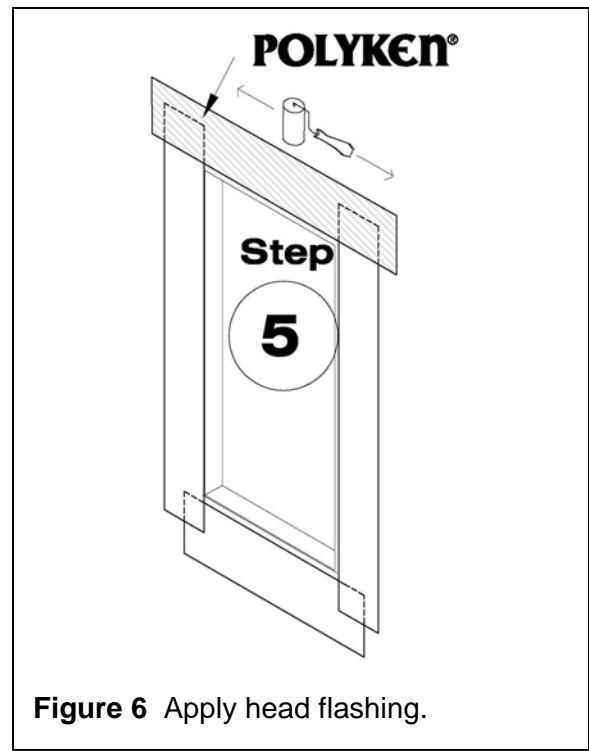
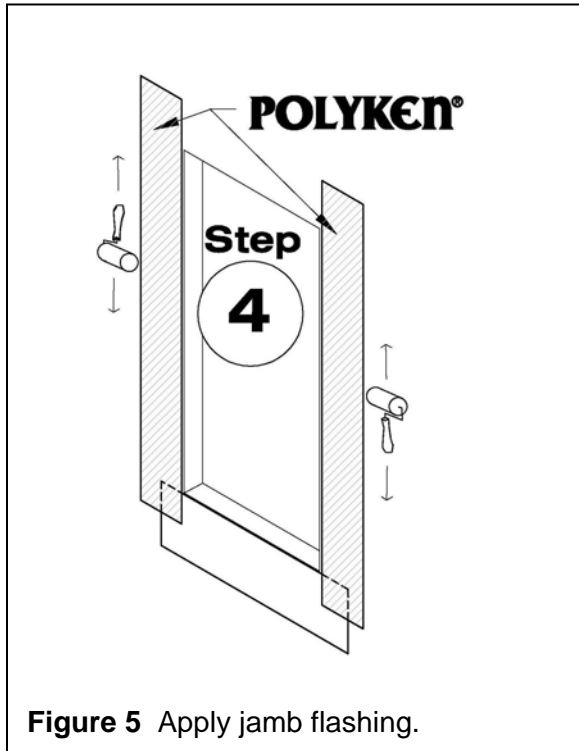

Figure 4 Install pan flashing where occurs.

Step 4. Precut Polyken® or Nashua® jamb flashing tape to extend a minimum of 6" above and below the rough opening. Peel off release liner and adhere Polyken® or Nashua® jamb flashing over the jamb fins and over top of Polyken® or Nashua® sill flashing (see Figure 5).

Step 5. Precut Polyken® or Nashua® head flashing tape to extend a minimum of 6" beyond the jambs of the rough opening. Peel off release liner and adhere Polyken® or Nashua® head flashing over head opening and jamb flashings (see Figure 6).



Step 6. Install door in opening (see Figure 7).

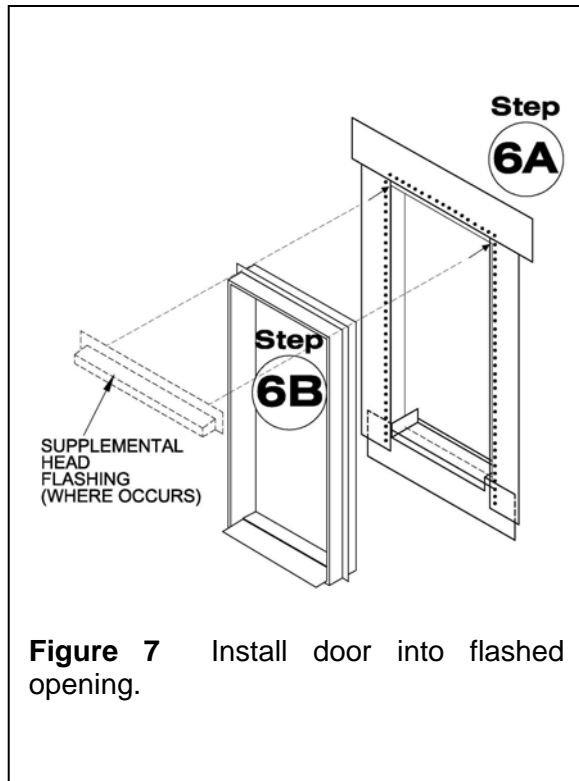

Figure 7 Install door into flashed opening.

adhere to WRB. Seal edges of WRB to door jamb and head (see Figure 10).

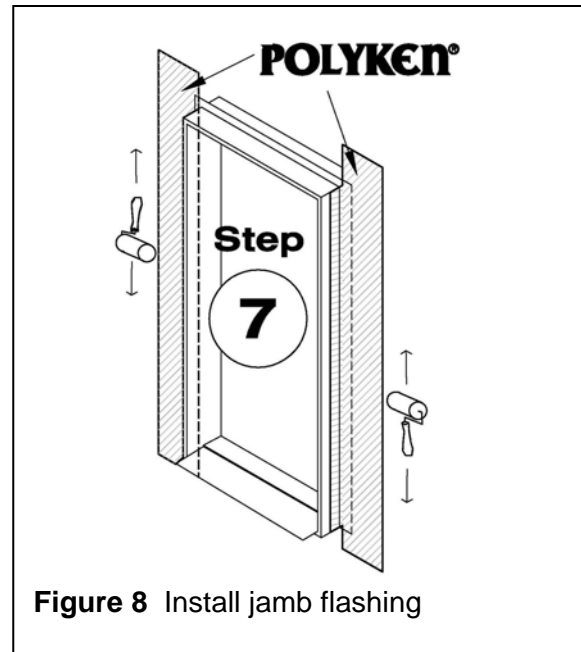

Figure 8 Install jamb flashing

Step 7. Precut Polyken® or Nashua® jamb flashing tape to extend 4” minimum above head and 4” minimum below sill (unless deck or slab interferes). Peel off release liner and adhere membrane over jamb finds and into frame. Refer to General Application Guide, Condition 3.

Step 8. Precut Polyken® head flashing tape to extend a minimum of 6” beyond the jambs of the rough opening. Peel off release liner and adhere Polyken® membrane over door fin and optional preformed head flashing (see Figure 9).

Step 9. Install weather-resistant barrier (WRB) shingle fashion from bottom of wall to top. Integrate sill flashing by inserting WRB under sill flashing. Peel off remaining release liner from Polyken® sill flashing and

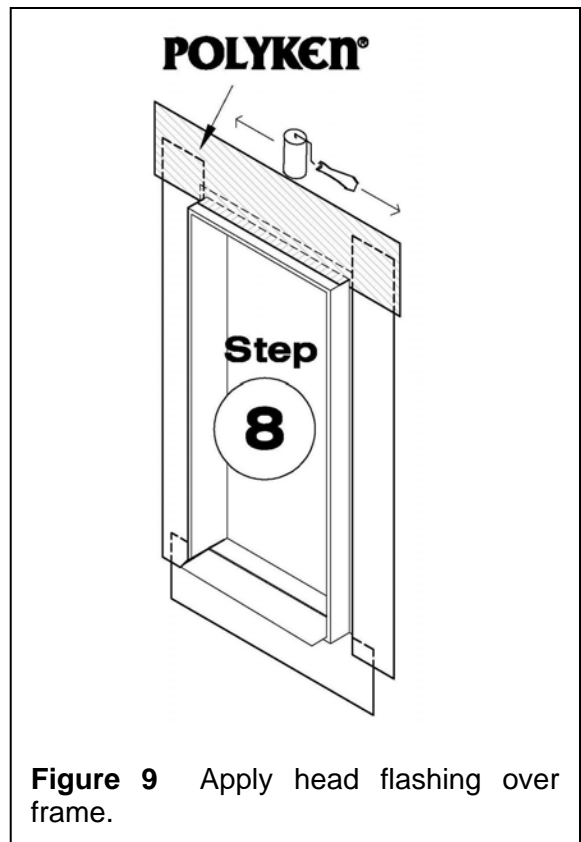

Figure 9 Apply head flashing over frame.

Step 10. Install trim and/or exterior wall cladding around perimeter of door. Seal perimeter joints per the recommendations of the cladding and door manufacturers (see Figure 11).

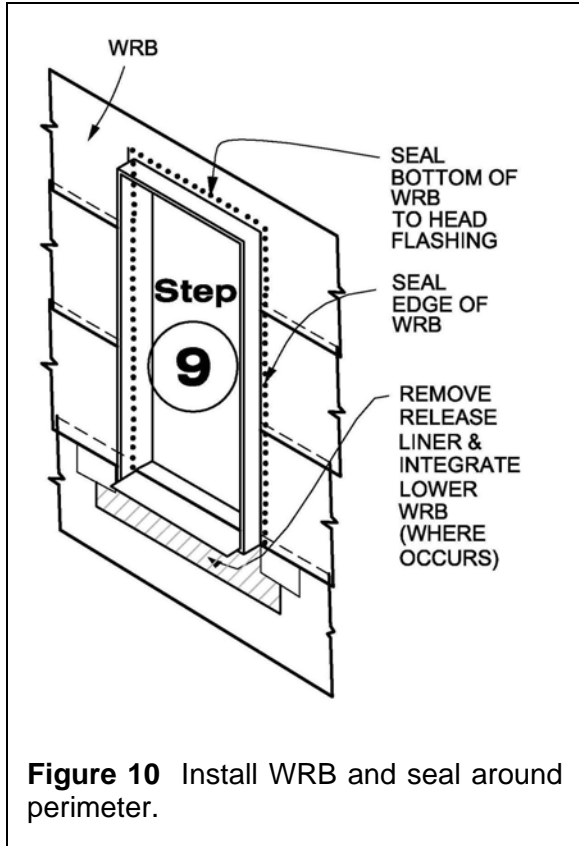

Figure 10 Install WRB and seal around perimeter.

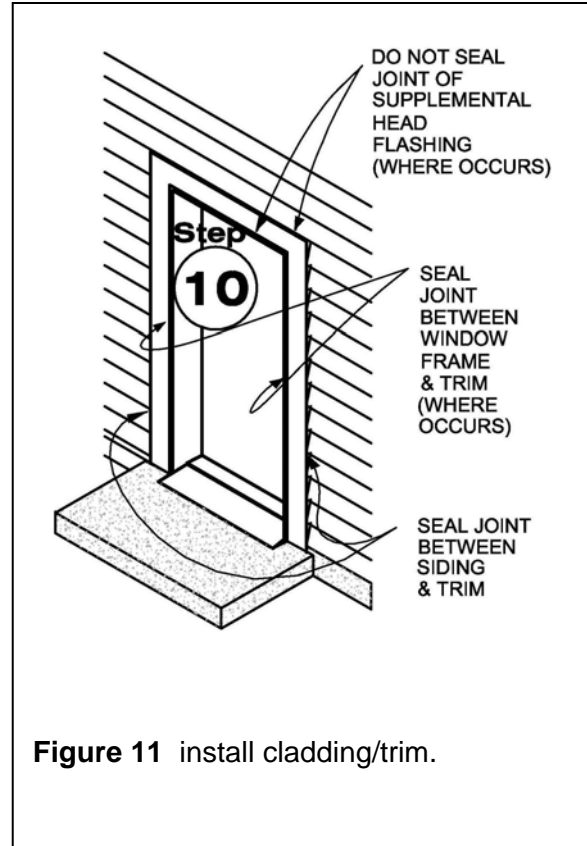

Figure 11 install cladding/trim.

Notice: The final determination of the sealing of joints between cladding, trim, and frame is not the responsibility of Berry Plastics.

Type 1 Flush Mount and Type 3 Integral Curb Skylight Flashing – Method SP-1/3

The following diagrams illustrate skylight flashing installation procedures that modify the method described in ASTM E2112-07 Standard Practice for Installation of Exterior Windows, Doors and Skylights. A strip of Polyken® or Nashua® Flashing Tape is

substituted for the roof mastic shown in the ASTM method. This sequence is for skylights that have an integral curb with a flange in the roof plane. The method presumes the roofing is asphalt shingles; the sequence is easily modified to accommodate other steep roofing systems. Figure 1 is an exploded view showing the flashing sequence.

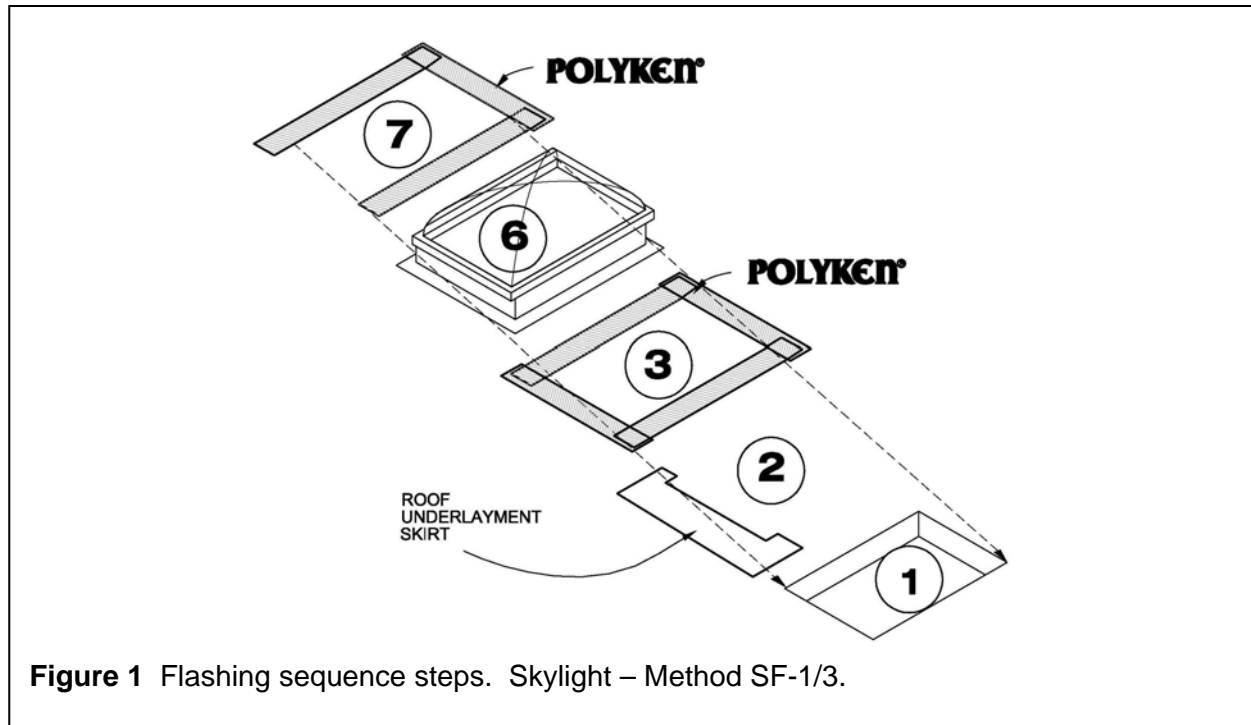

Figure 1 Flashing sequence steps. Skylight – Method SF-1/3.

Step 1. Prepare skylight rough opening. Clear a margin of solid, smooth substrate around the opening perimeter (see Figure 2).

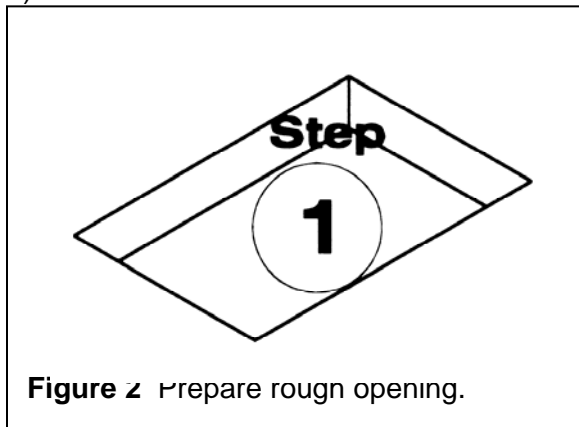

Figure 2 Prepare rough opening.

Step 2. Install a skirt of roof underlayment along the sill of the skylight opening. The remaining underlayment will be integrated with this skirt in Step 4 (see Figure 3).

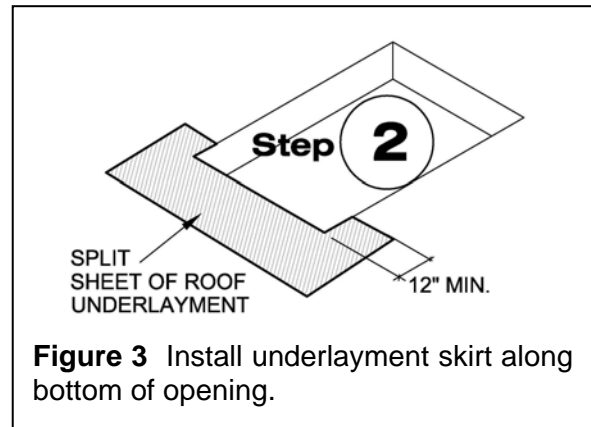

Figure 3 Install underlayment skirt along bottom of opening.

Step 3. Apply strips of Polyken® or Nashua® flashing around the opening starting with the sill, then the sides, and the head. Extend Polyken® or Nashua® flashing a minimum of 6" beyond the opening on all sides. Hand roller strips and laps flat to substrate at sides and to underlayment skirt at sill (see Figure 4).

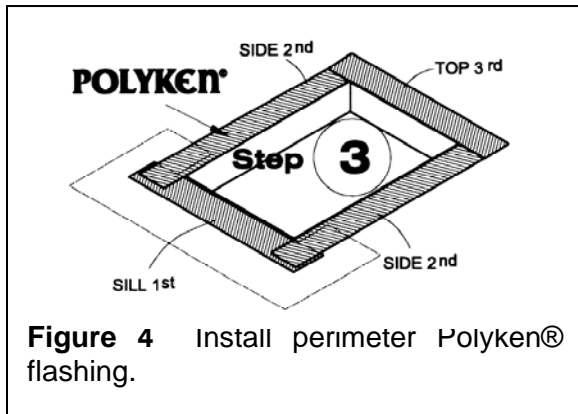

Figure 4 Install perimeter Polyken® flashing.

Notice: The following installation details and sequence of skylights, underlayments, and roof coverings is not the responsibility of Berry Plastics. Consult specific product manufacturers.

Step 4. Install the roof underlayment in shingle fashion with the course below the skylight. Continue to lay out the underlayment around the sides and head (see Figure 5).

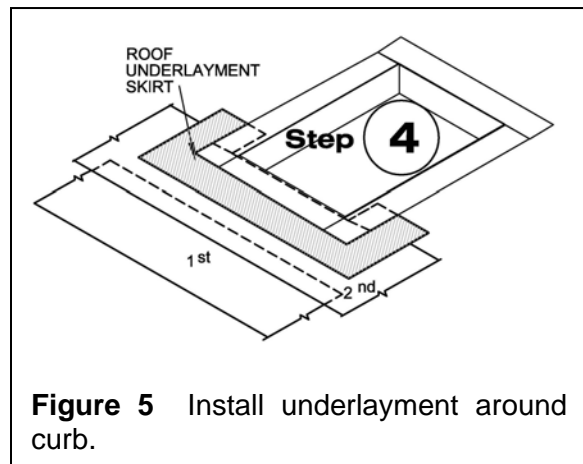

Figure 5 Install underlayment around curb.

Step 5. Install a portion of roof covering below the skylight sill curb. Coordinate position of roofing with final layout (see Figure 6).

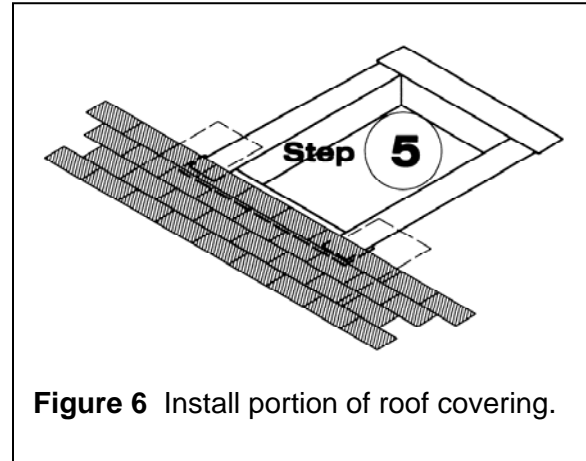

Figure 6 Install portion of roof covering.

Step 6. Seal edge of roofing at sides and head to underlayment. Keep edge of roofing 1/2" minimum from main body of skylight frame.

Install skylight over perimeter Polyken® or Nashua® flashing strips. (Bed in bead of sealant optional). Fasten sides and top per skylight manufacturer. Do not fasten at bottom (see Figure 7).

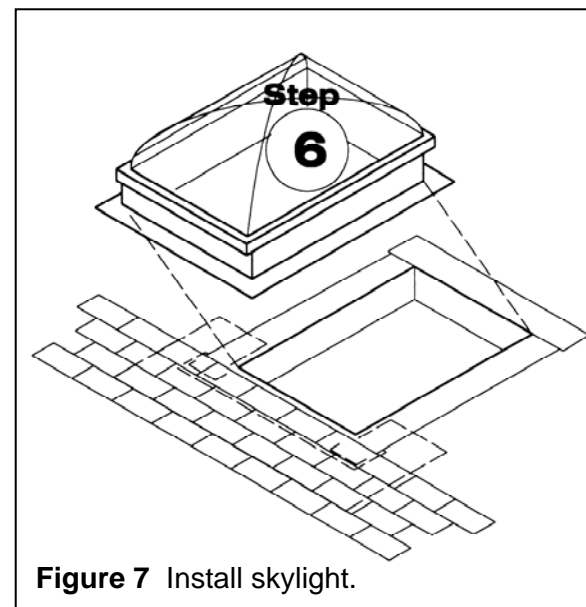

Figure 7 Install skylight.

Step 7. Apply Polyken® or Nashua® flashing strips along both sides of skylight over flange extending a minimum of 6" above top of opening. Using a hand roller, roll strips flat to flange and underlying Polyken® or Nashua® flashing strip at opening perimeter. Apply Polyken® or Nashua® flashing strip across top (head) of skylight frame covering flange and lapping onto underlying Polyken® or Nashua® flashing strips. Roll head flashing flat (see Figure 8).

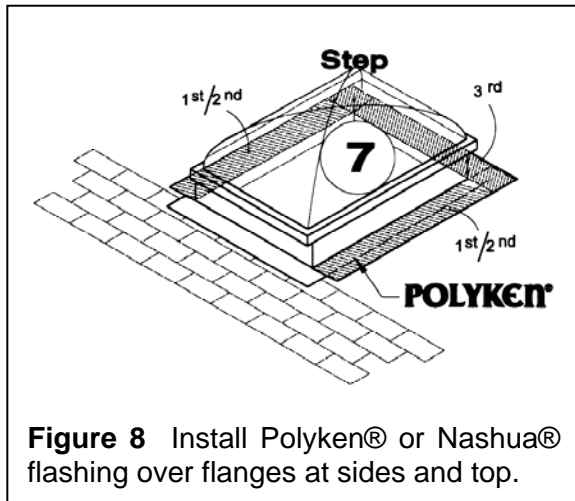

Figure 8 Install Polyken® or Nashua® flashing over flanges at sides and top.

Step 8. Complete installation of roof underlayment in shingle fashion. Tuck underlayment under skirt at sill. Continue to lay out the underlayment around the sides and head. Install underlayment over Polyken® or Nashua® flashing strips at jambs and head. Cut underlayment edges back ½" to 1" back from edge of the main skylight frame. Seal the edges of the underlayment to the Polyken® or Nashua® flashing strips (see Figure 9).

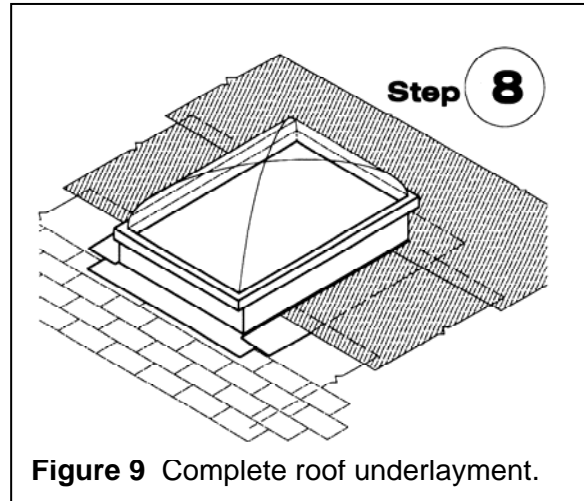

Figure 9 Complete roof underlayment.

Keep the underlayment at the sides from extending below the sill edge of the skylight frame.

Step 9. Complete roof covering installation. Seal edge of roofing at sides (jamb) and head (top) to underlayment with roof mastic. Keep edge of roofing ½" minimum from main body of skylight frame.

Type 2 Curb Mount and Type 4 Inset Mount Skylight Flashing – Method SP – 2/4

The following diagrams illustrate skylight flashing procedures that modify the method described in ASTM E2112-07 Standard Practice for Installation of Exterior Windows, Doors and Skylights. A strip of Polyken® or

Nashua® Flashing Tape is substituted for the roof mastic shown in the ASTM method. This sequence is for skylights that mount on a separate, site built or prefabricated curbs. The method presumes the roofing is asphalt shingles; the sequence is easily modified to accommodate other steep roofing systems. Figure 1 is an exploded view showing the flashing sequence.

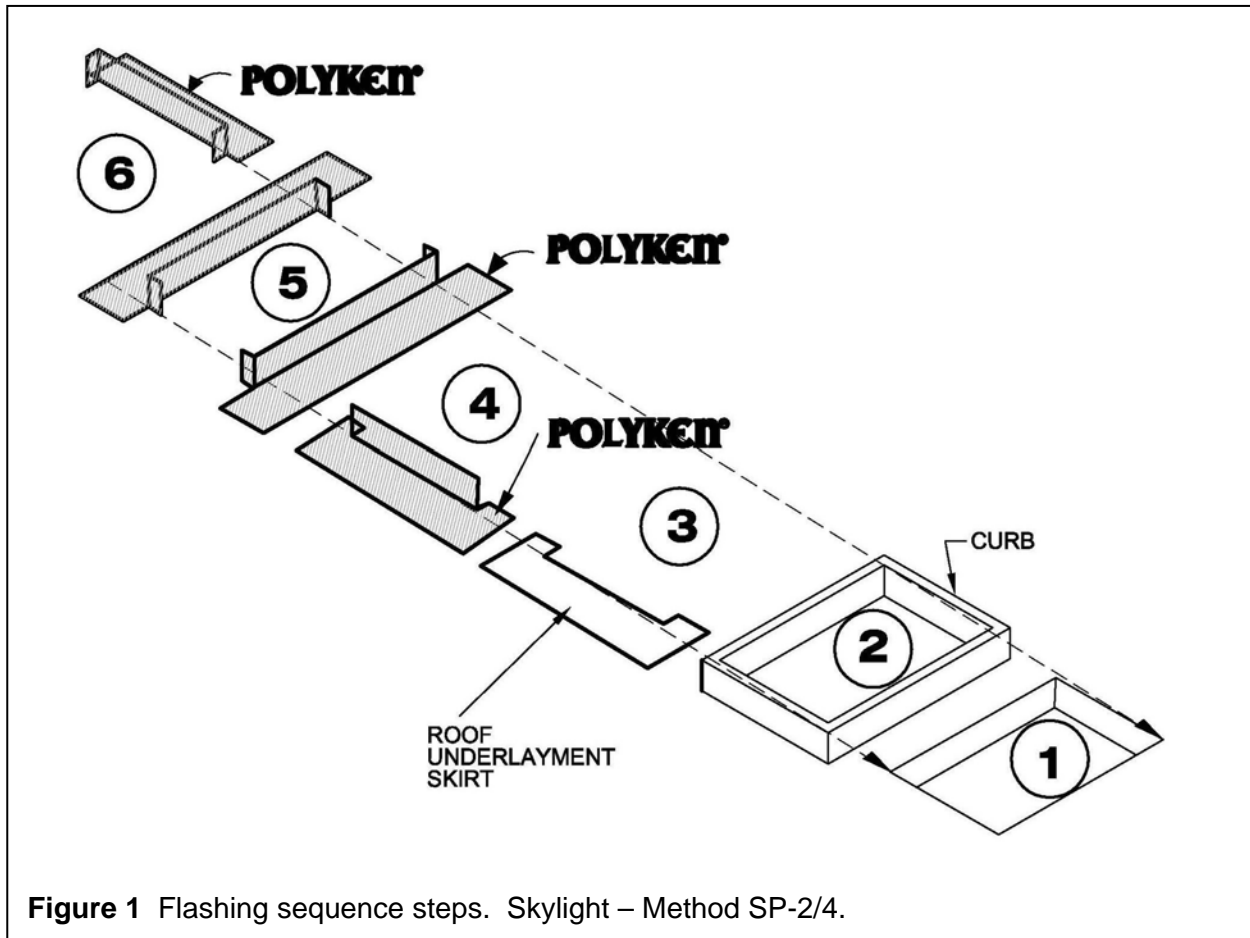

Figure 1 Flashing sequence steps. Skylight – Method SP-2/4.

Step 1. Prepare skylight rough opening. Clear a margin of solid, smooth substrate around the opening perimeter (see Figure 2).

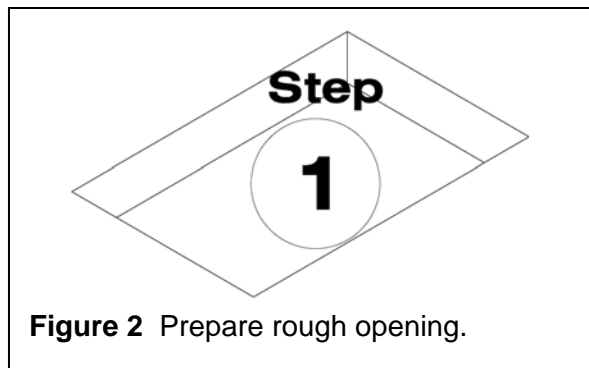

Figure 2 Prepare rough opening.

Step 2. Construct the perimeter curb around the skylight rough opening. Comply with skylight manufacturer's recommendations and building code requirements (see Figure 3).

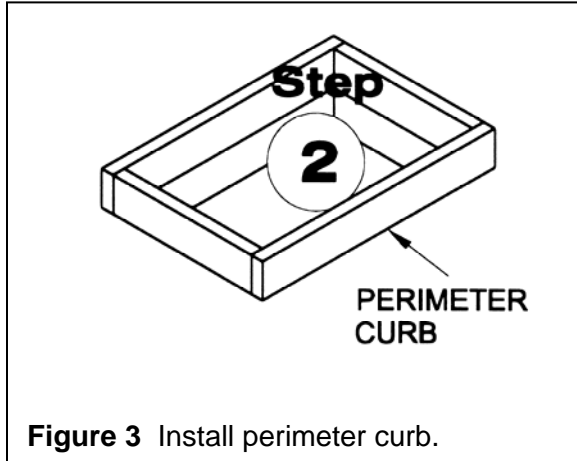

Figure 3 Install perimeter curb.

Step 3. Install a skirt of roof underlayment along the bottom of the skylight opening. The remaining roof underlayment will be integrated with this skirt in Step 8. (see Figure 4). Apply a strip of Polyken® or Nashua® flashing along the bottom (sill) of the skylight curb, lapping up the vertical leg of curb and across the skirt of roof underlayment. Extend the ends of sill flashing tape beyond the curb 6" minimum. Roll the strip flat. Caution: Do not tear Polyken® or Nashua® in angle (see

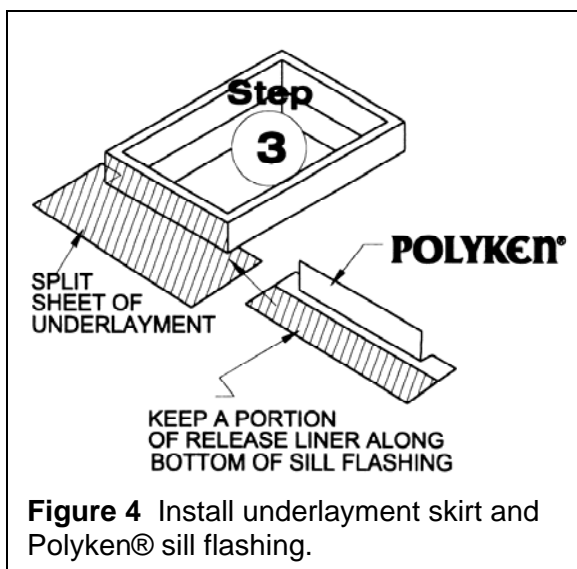

Figure 4 Install underlayment skirt and Polyken® sill flashing.

Application Guide – General).

Step 4. Apply Polyken® or Nashua® circle boots at lower curb corners (see Figure 5).

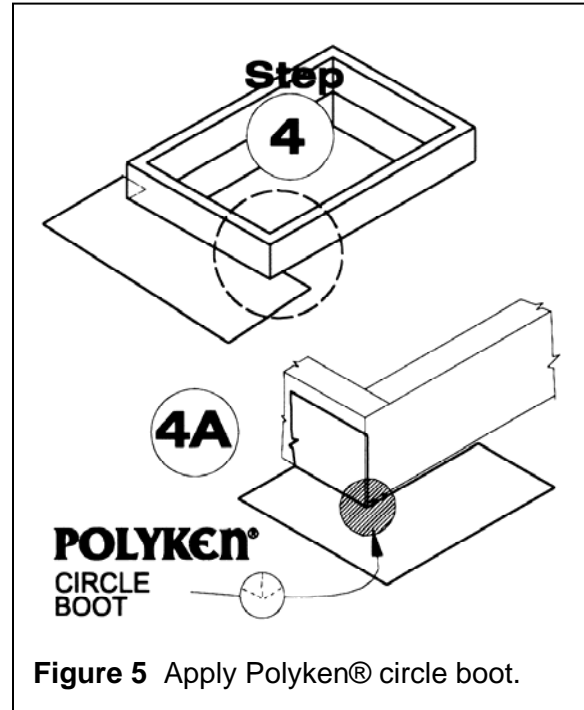

Figure 5 Apply Polyken® circle boot.

Step 5. Apply Polyken® or Nashua® flashing strips along both sides of the skylight opening curb. Lap Polyken® or Nashua® up the vertical leg of curb and across the roof substrate. Lap the bottom ends of side flashing a minimum of 6” over the ends of the sill flashing tape. Extend the top ends a minimum of 6” beyond the top of the curb. Carefully roll the strips and laps flat. Do not tear the vertical-to-horizontal juncture (see Figure 6).

Step 5a. Apply circle boots of Polyken® (approximately 3 in. in diameter) at the upper corners of the skylight curb (see Figure 6). (Follow instructions in the Application Guide – General.)

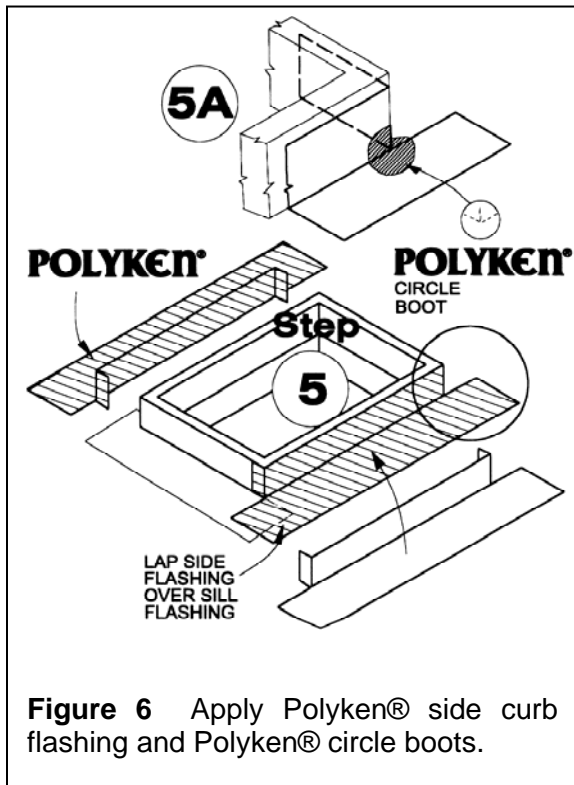

Figure 6 Apply Polyken® side curb flashing and Polyken® circle boots.

Step 6. Apply Polyken® or Nashua® flashing strip across top of skylight curb, lapping up the vertical leg of curb and across the roof substrate. Lap the vertical ends over the ends of the side flashing tapes (see Figure 7).

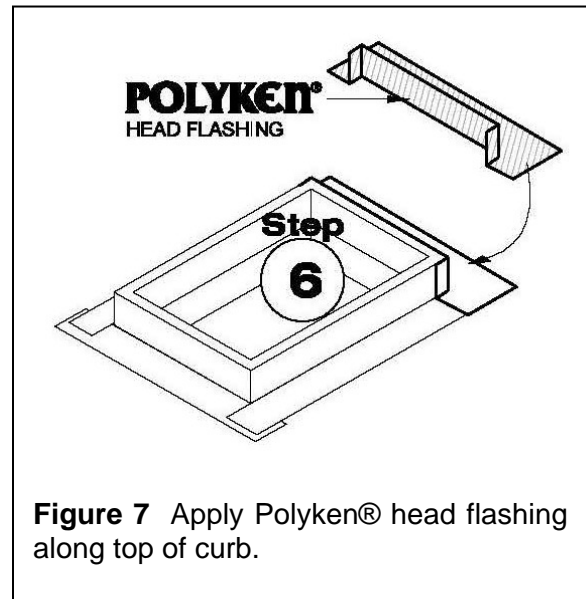
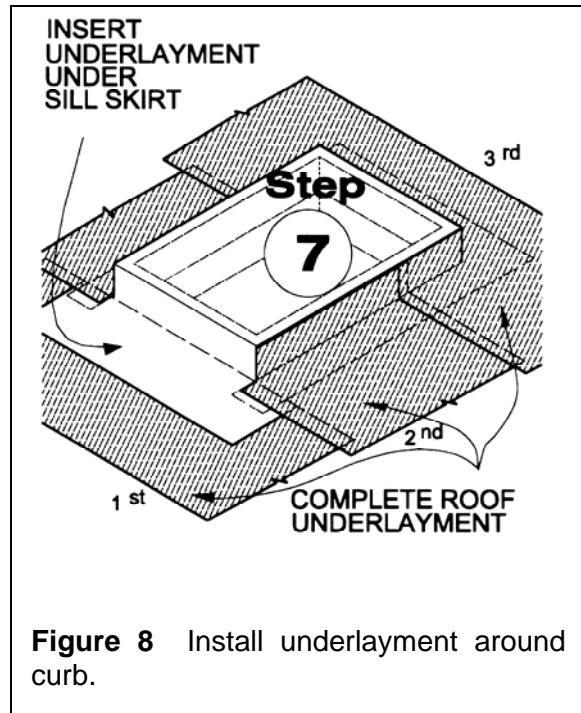

Figure 7 Apply Polyken® head flashing along top of curb.

Keep the underlayment at the sides from extending below the sill edge of the skylight frame.

Step 7. Complete installation of roof underlayment in shingle fashion. Tuck underlayment under skirt at sill. Continue to lay out the underlayment around the sides and head. Fold the underlayment up the curb at the sides and head (see Figure 8).



Step 8. Install a portion of roof covering below the skylight bottom (sill) curb. Coordinate position of roofing with final layout (see Figure 9).

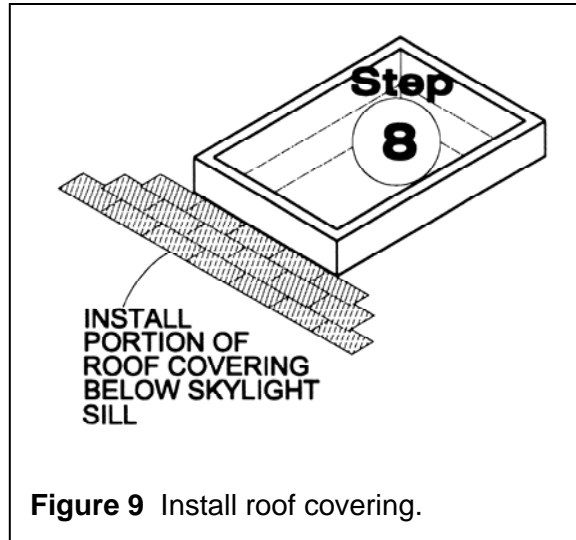

Step 9. Install sheet metal sill apron flashing at bottom of skylight curb. Insert top ends of sheet metal flashing under roof underlayment. Cut and modify roof underlayment as required to lap over top edges of sheet metal flashing (see Figure 10).

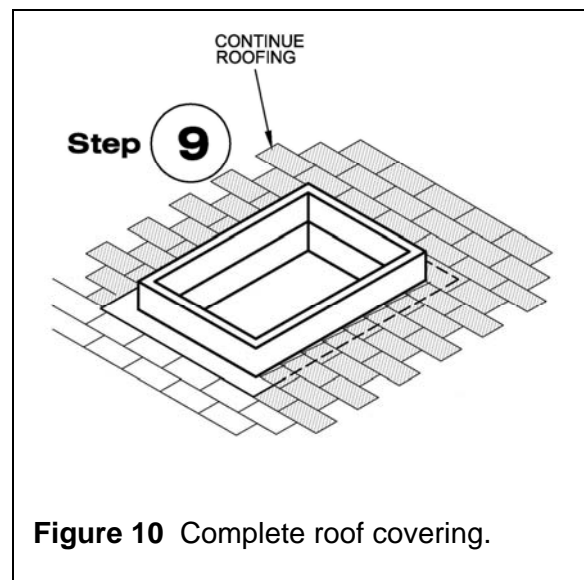

Notice: The following installation details and sequence of skylights, underlayments, and roof coverings is not the responsibility of Berry Plastics. Consult specific product manufacturers.

Step 10. Install metal step shingle flashing and interweave with roof covering along sides of skylight curb.

Install sheet metal head flashing (saddle flashing or cricket type flashing) across top of skylight curb. (Note: Generally, skylight widths greater than 24 inches should have a cricket type flashing on the upslope side.) Cut roof underlayment along top of flashing edge and insert top of saddle underneath roof underlayment to lap a minimum of 6 inches. Seal bottom edge of roof underlayment to flange of head flashing (see Figure 11).

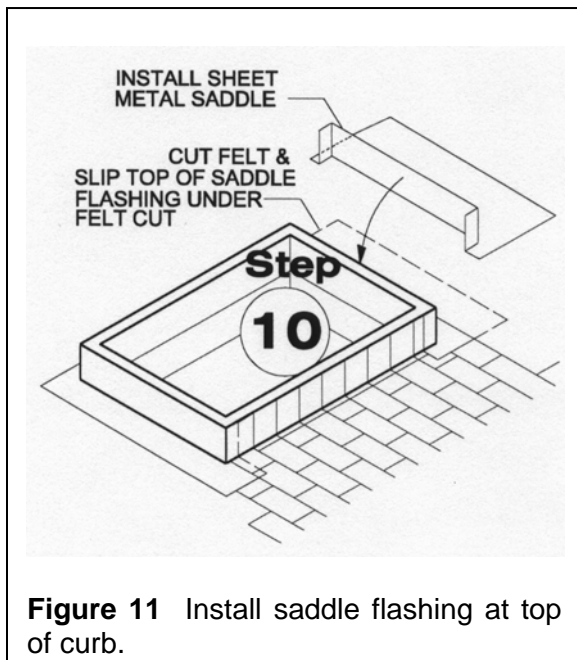

Figure 11 Install saddle flashing at top of curb.

Step 11. Complete roof covering along top of skylight. Do not install roof covering too close to curb of skylight to allow proper drainage and to avoid a pocket for debris build-up. Follow skylight and roof covering manufacturers' recommendations (see Figure 12).

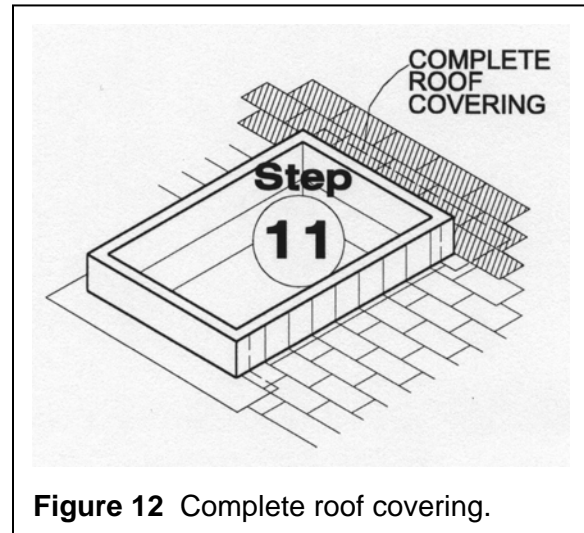
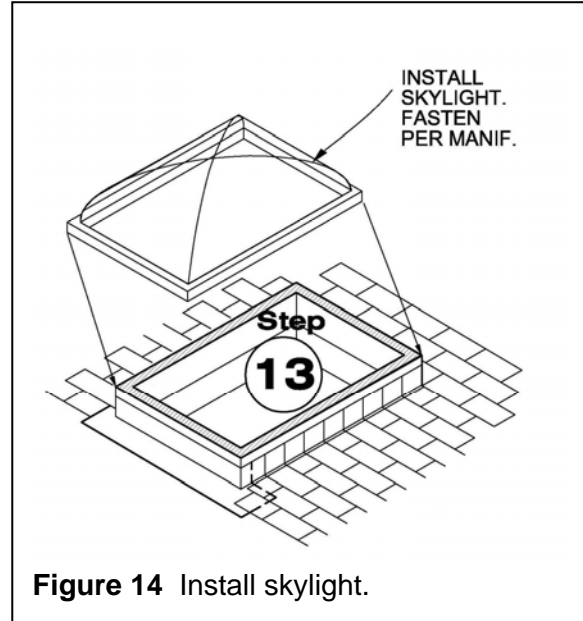
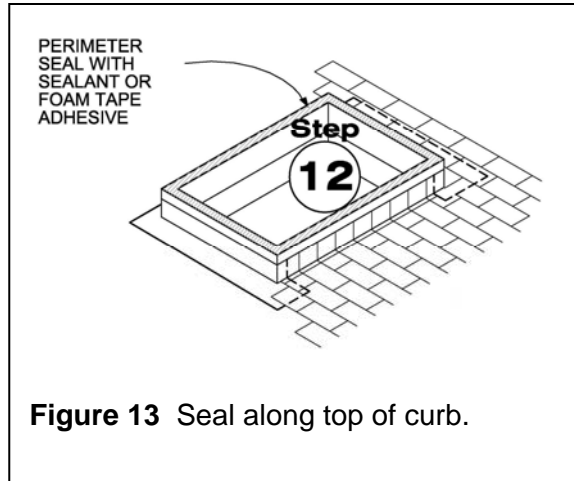

Figure 12 Complete roof covering.

Step 12. Install a bead of sealant around top of roof curb or use a foam adhesive tape for future skylight removal (see Figure 13). Another option is to apply a strip of Polyken® or Nashua® flashing tape as counterflashing for the skylight curb flashing.

Step 13. Install skylight. Fasten per skylight manufacturer's recommendations (see Figure 14).



Nashua® “Contour™” Flashing Tapes

Contour™ Flashing Tape is a self-adhering flashing tape with a flexible and stretchable facing developed to conform to irregular substrate configurations, such as arches and recessed sills. It can stretch to cover multiple bends at outside and inside corners of recessed openings. It is able to form to arched openings in one piece. Contour™ is able to conform to intersecting wall angles to produce a one-piece sill pan flashing including recessed openings. The butyl adhesive of Contour flashing tape provides excellent adhesion to substrates.

Contour™ Flashing Tapes can be substituted for the other Polyken® and Nashua® Flashing tapes on a one-for-one basis in the details shown by this guide.

The following details illustrate some examples of Contour™ Flashing Tape for arched windows recessed openings and sill pan flashing.

Contour™ Flashing Sequence Diagrams									
Detail #	Opening Type		WRB Type		Head Opening		Frame Type		Sill Pan Included
	Flush	Recess	Building Paper	House Wrap	Straight	Arch	Nail Fin	Box	
RSH		X		X	X		X		Yes
RSB		X	X		X		X		Yes
RAH		X		X		X	X		Yes
RAB		X	X			X	X		Yes
FAH	X			X		X	X		No
FAB	X		X			X	X		No

Note: The window sill and opening recess details above can be adapted for door openings.

:Projects\2006\067220-POLY\Drafting\Working_Set\Details\7.0_Contour Flashing Sequence Diagrams\POLY_Fig7.1_CFSH_01.dwg, 10/15/2007 3:19:55 PM, mfpowers

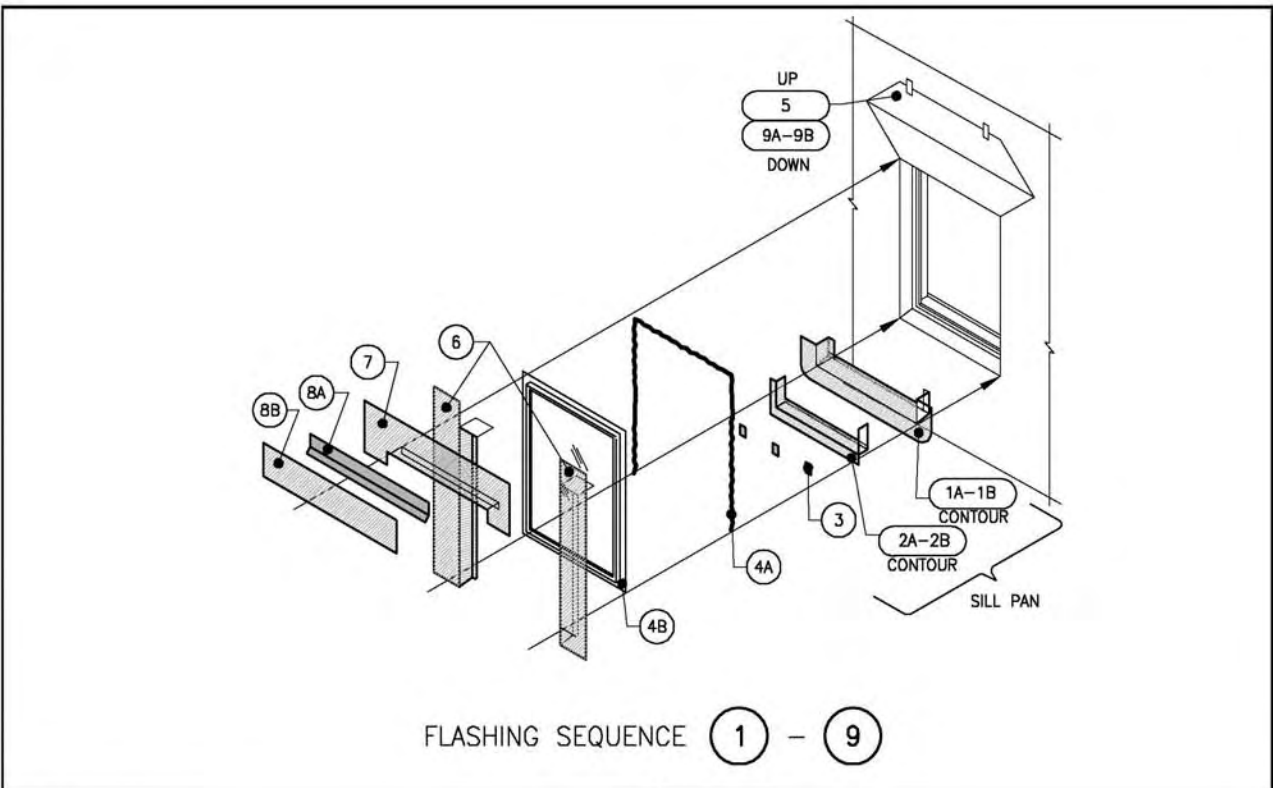

FLASHING SEQUENCE (1) - (9)

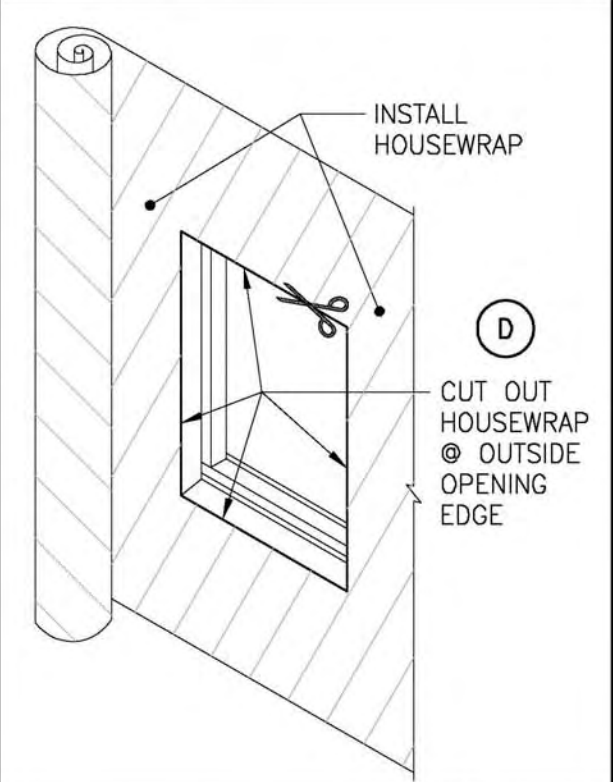
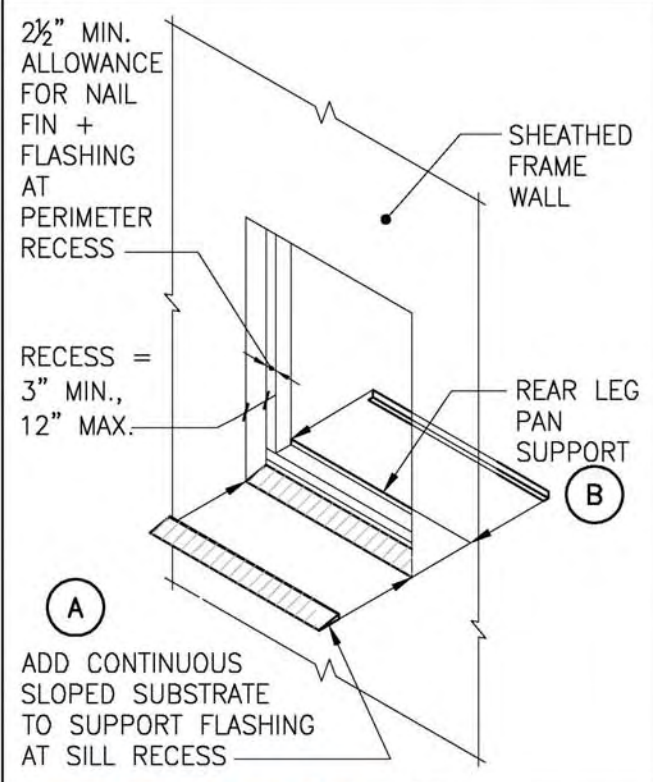

Project: RECESSED OPENING, HOUSEWRAP NAIL-FIN, STRAIGHT HEAD
 Title: CONTOUR WINDOW FLASHING, METHOD A1

Drawing No.: RSH.1

:\Projects\2006\067220-POLY\Drafting\Working_Set\Details\7.0_Contour Flashing Sequence Diagrams\POLY_Fig7.1_CFSH_01.dwg, 10/15/2007 3:19:57 PM, wtpowers

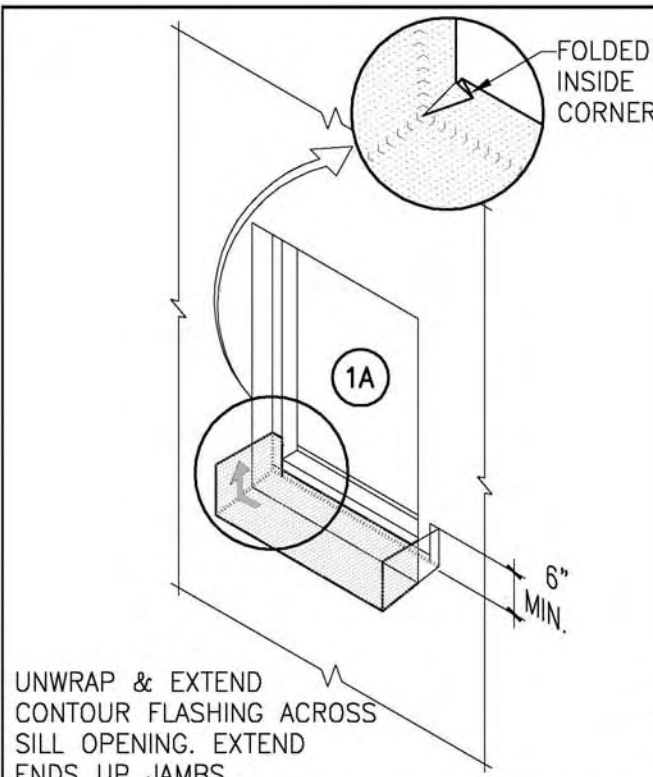

UNWRAP & EXTEND CONTOUR FLASHING ACROSS SILL OPENING. EXTEND ENDS UP JAMBS

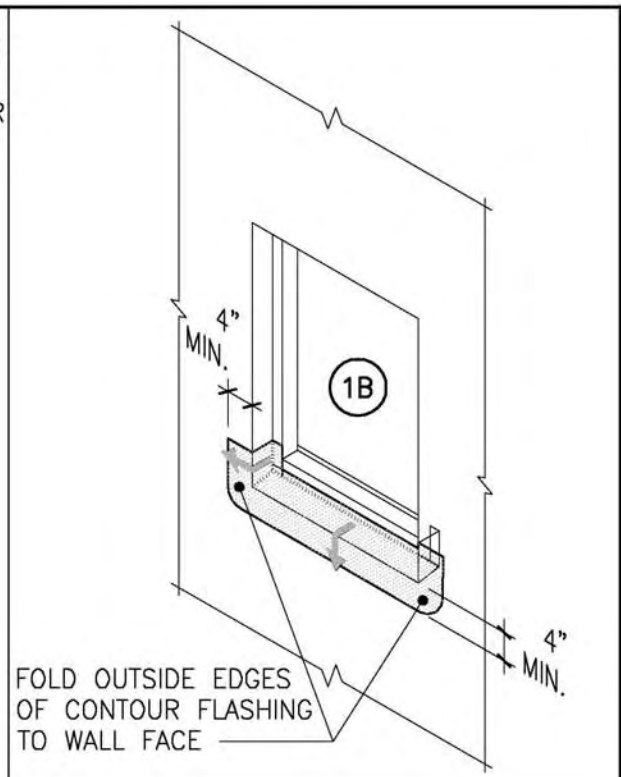

FOLD OUTSIDE EDGES OF CONTOUR FLASHING TO WALL FACE

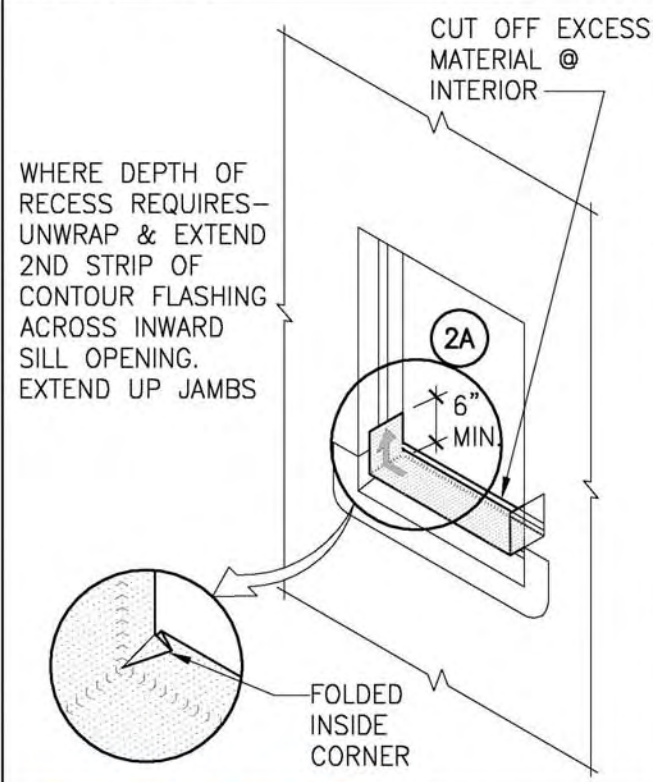

WHERE DEPTH OF RECESS REQUIRES—UNWRAP & EXTEND 2ND STRIP OF CONTOUR FLASHING ACROSS INWARD SILL OPENING. EXTEND UP JAMBS

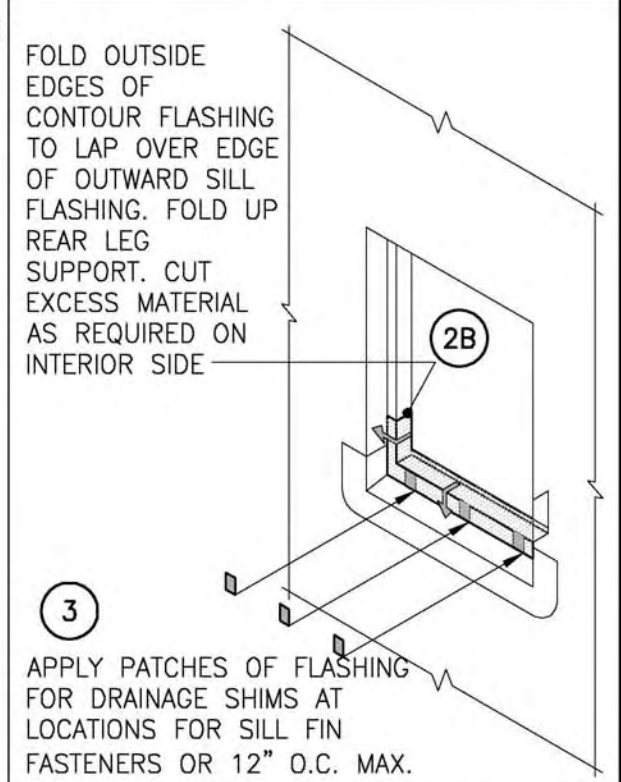

APPLY PATCHES OF FLASHING FOR DRAINAGE SHIMS AT LOCATIONS FOR SILL FIN FASTENERS OR 12" O.C. MAX.



Project: RECESSED OPENING, HOUSEWRAP NAIL-FIN, STRAIGHT HEAD

Title: CONTOUR WINDOW FLASHING, METHOD A1

Drawing No: RSH.2

I:\Projects\2006\067220-POLY\Drafting\Working_Set\Details\7.0_Contour Flashing Sequence Diagrams\POLY_Fig7.1_CFSH_01.dwg, 10/15/2007 3:19:57 PM, mfpowers

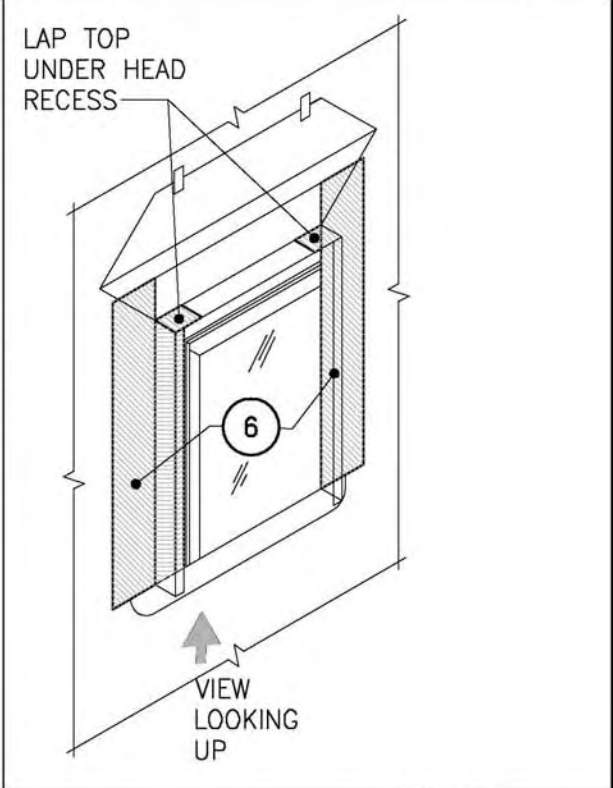
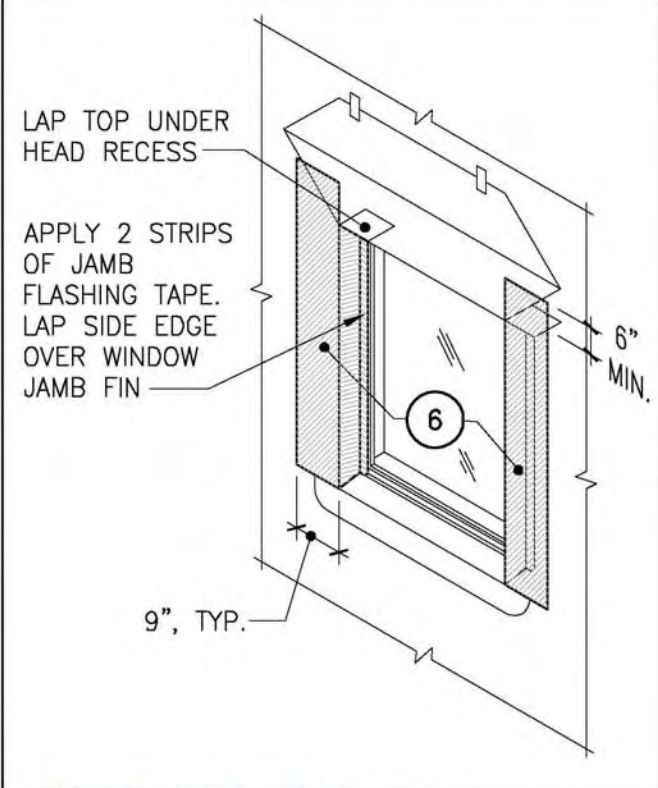
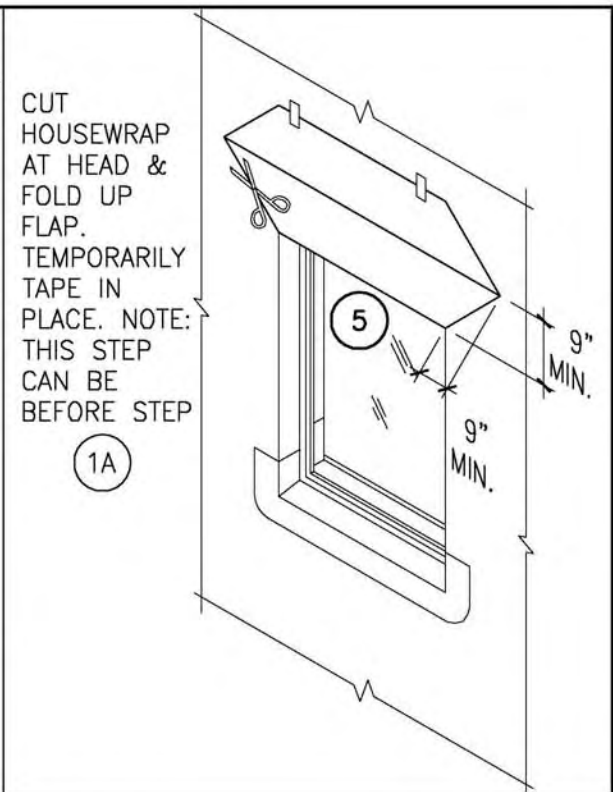
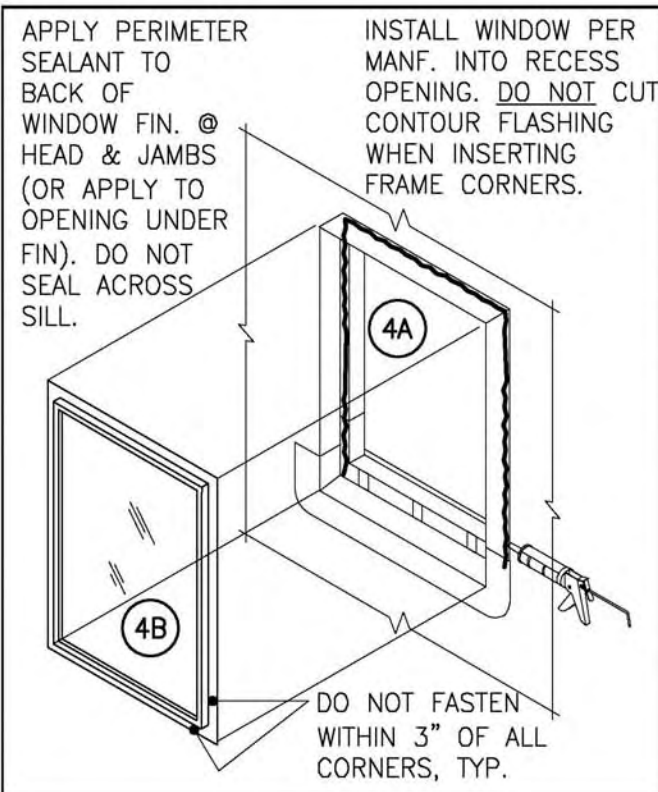

Project: RECESSED OPENING, HOUSEWRAP NAIL-FIN, STRAIGHT HEAD
Title: CONTOUR WINDOW FLASHING, METHOD A1

Drawing No.: RSH.3

:\Projects\2006\067220-POL\Y\Drafting\Working_Set\Details\7.0_Contour Flashing Sequence Diagrams\POL_Y_Fig7.1_CFSH_01.dwg, 10/15/2007 3:19:58 PM, wtpowers

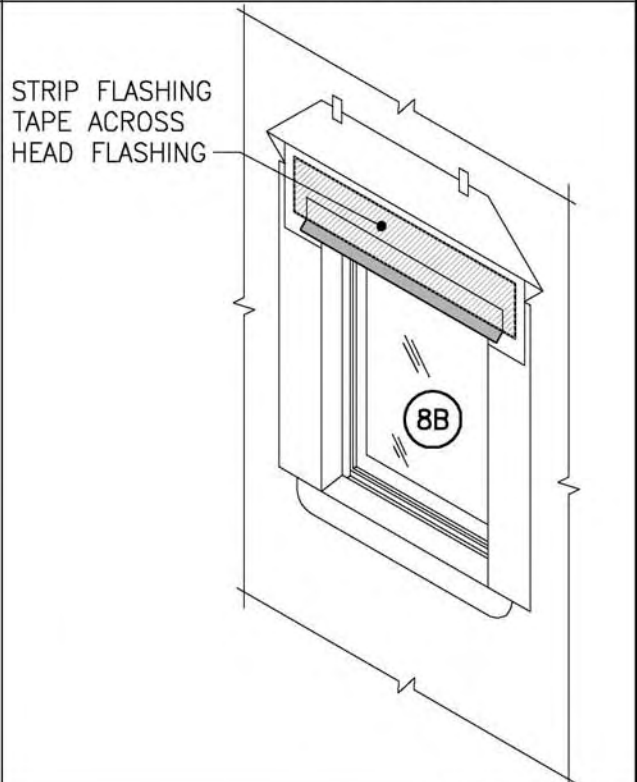
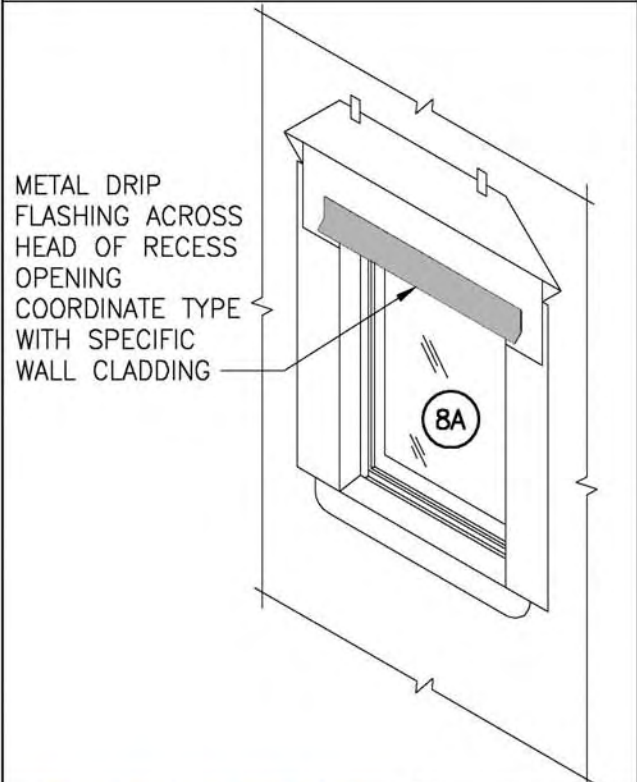
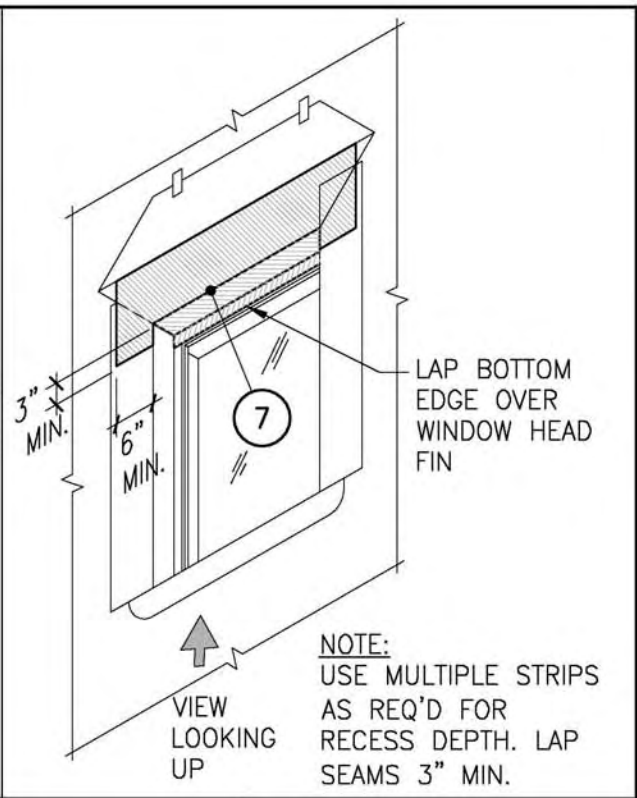
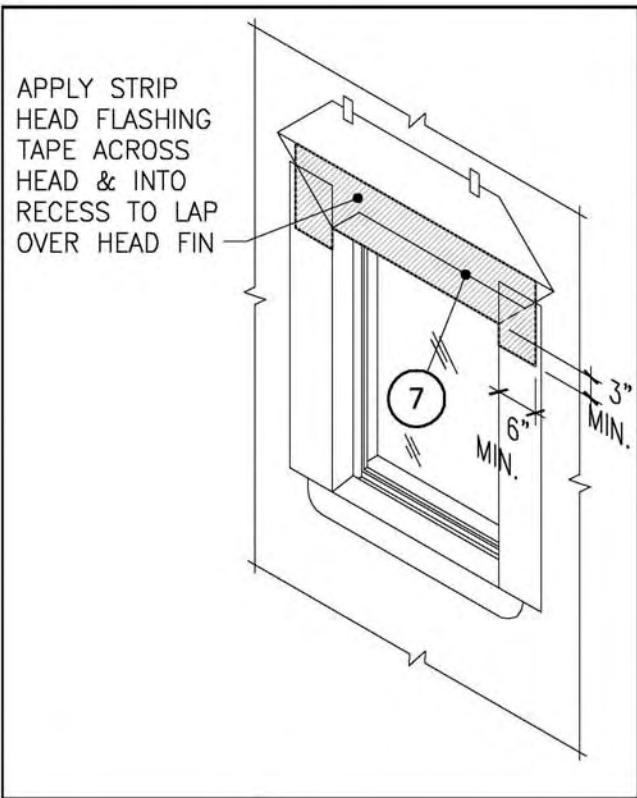

BERRYTM
PLASTICS CORPORATION
AND SUBSIDIARIES
TAPES AND COATINGS DIVISION

Project: RECESSED OPENING, HOUSEWRAP NAIL-FIN, STRAIGHT HEAD

Title: CONTOUR WINDOW FLASHING, METHOD A1

Drawing No: RSH.4

:\Projects\2006\067220-POL\Y\Drafting\Working_Set_Details\7.0_Contour Flashing Sequence Diagrams\POL_Y_Fig7.1_CFSH_01.dwg, 10/15/2007 3:19:58 PM, wtpowers

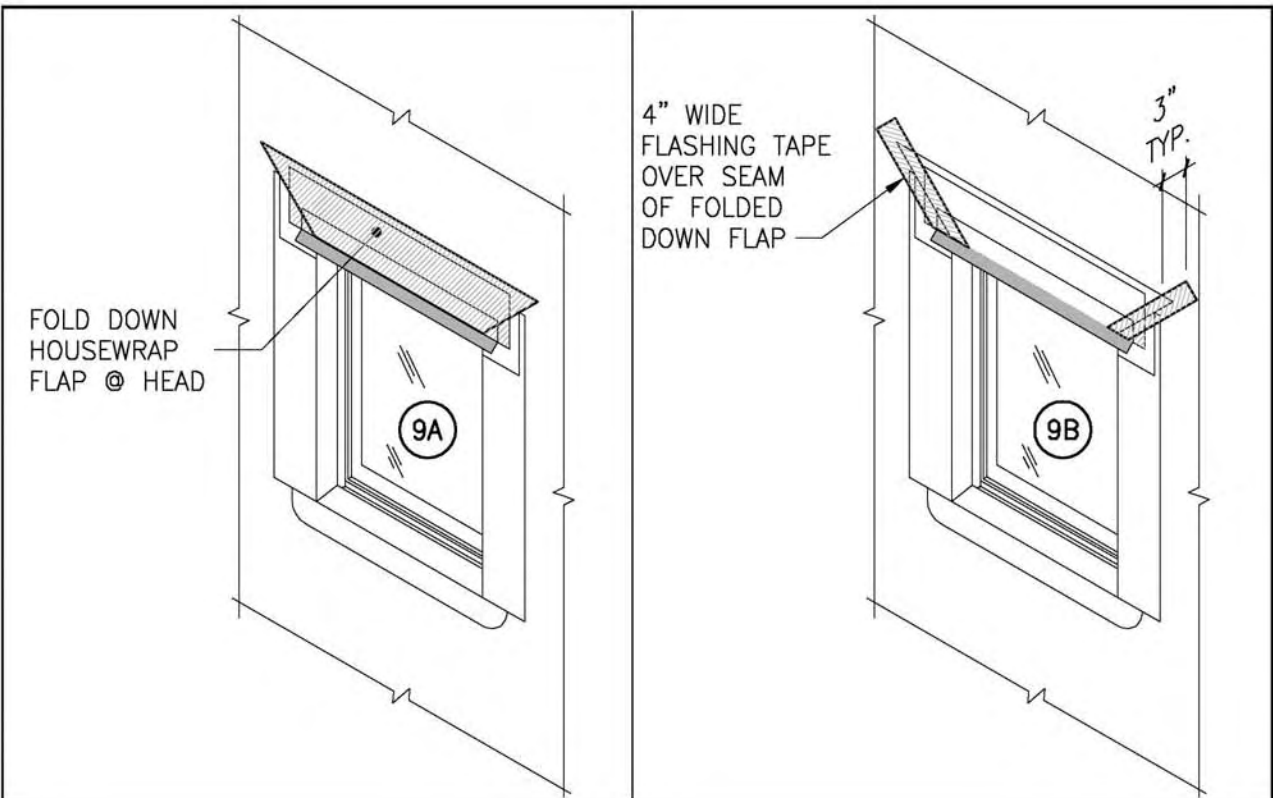

Project:
RECESSED OPENING, HOUSEWRAP
NAIL-FIN, STRAIGHT HEAD

Title:
CONTOUR WINDOW FLASHING, METHOD A1

Drawing No.:
RSH.5

I:\Projects\2006\067220-POLY\Drafting\Working_Set\Details\7.0_Contour Flashing Sequence Diagrams\POLY_Fig7.2_CRSB_01.dwg, 10/15/2007 3:20:03 PM, wtpowers

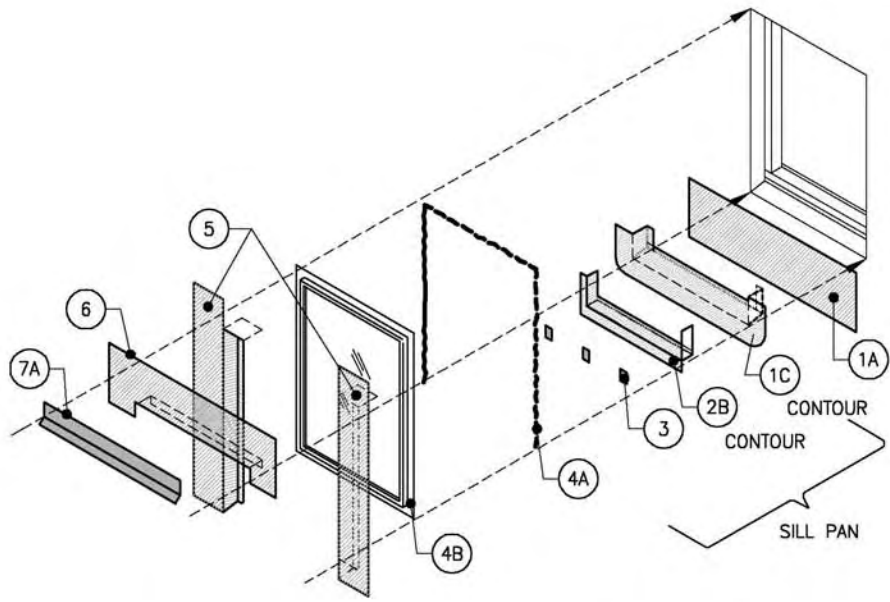

FLASHING SEQUENCE (1) - (7), BUILDING PAPER (8)

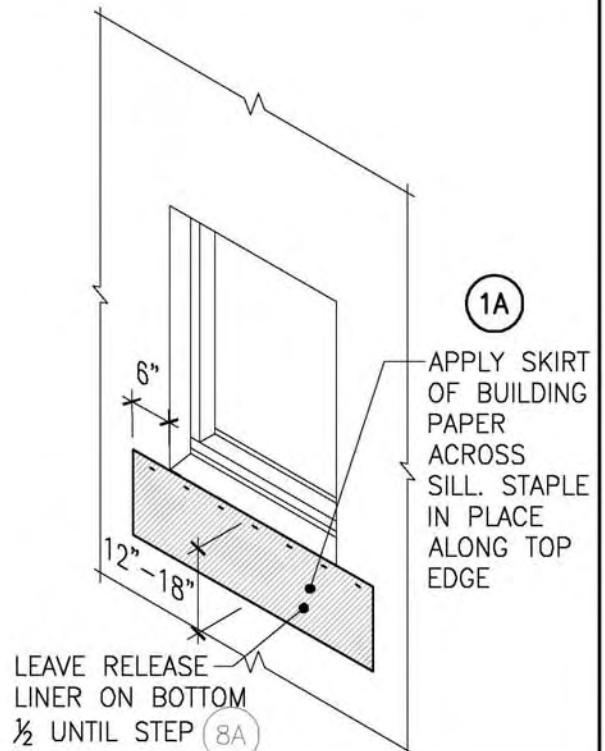
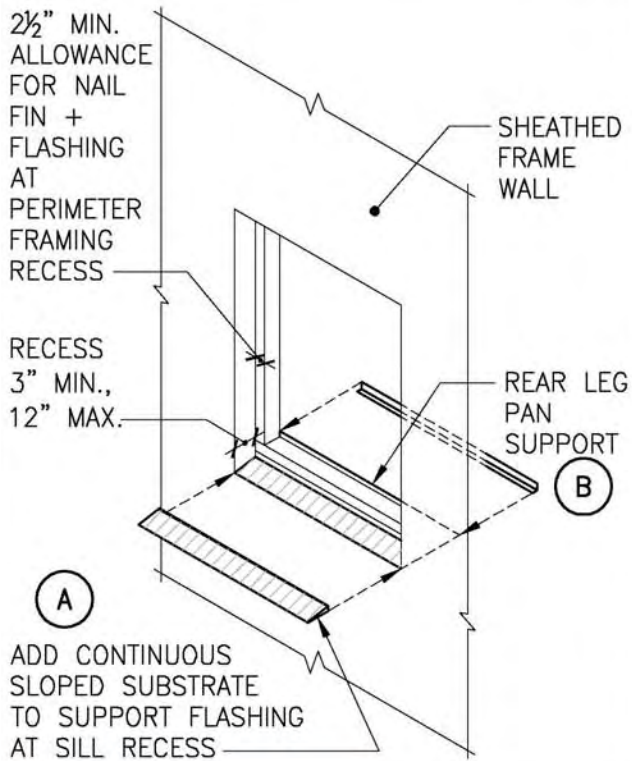

Project: RECESSED OPENING, BUILDING PAPER NAIL-FIN, STRAIGHT HEAD
 Title: CONTOUR WINDOW FLASHING, METHOD A

Drawing No.: RSB.1

:Projects\2006\067220-POLY(Drafting)\Working_Set_Details\7.0_Contour Flashing Sequence Diagrams\POLY_Fig7.2_CRSB_01.dwg, 10/15/2007 3:20:04 PM, wtpowers

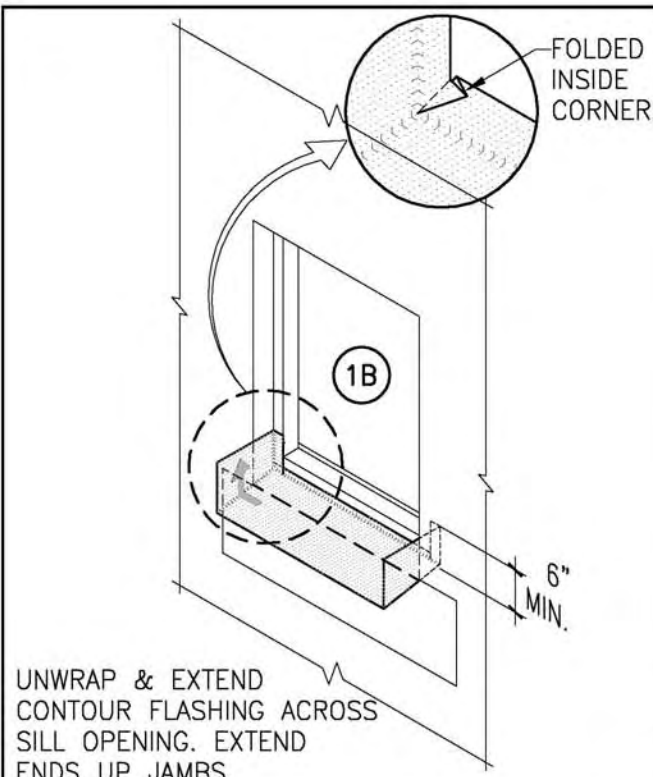

UNWRAP & EXTEND
 CONTOUR FLASHING ACROSS
 SILL OPENING. EXTEND
 ENDS UP JAMBS

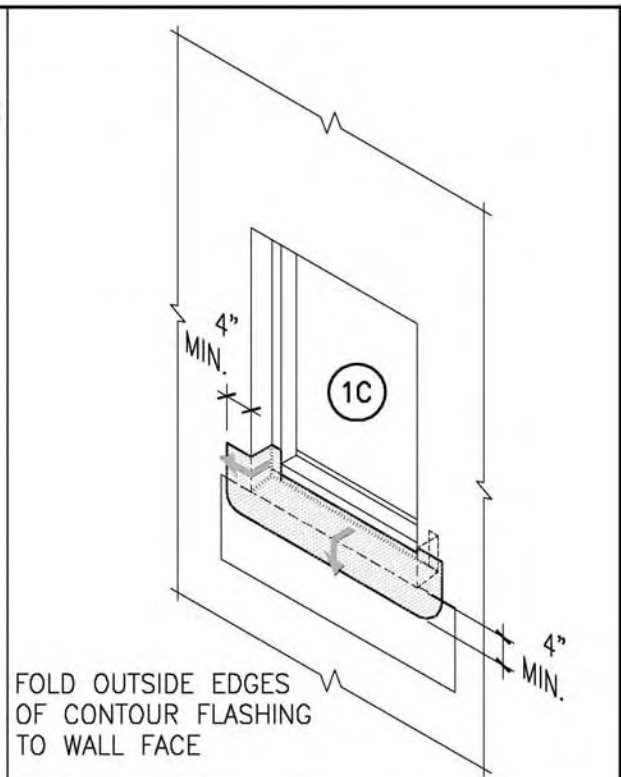

FOLD OUTSIDE EDGES
 OF CONTOUR FLASHING
 TO WALL FACE

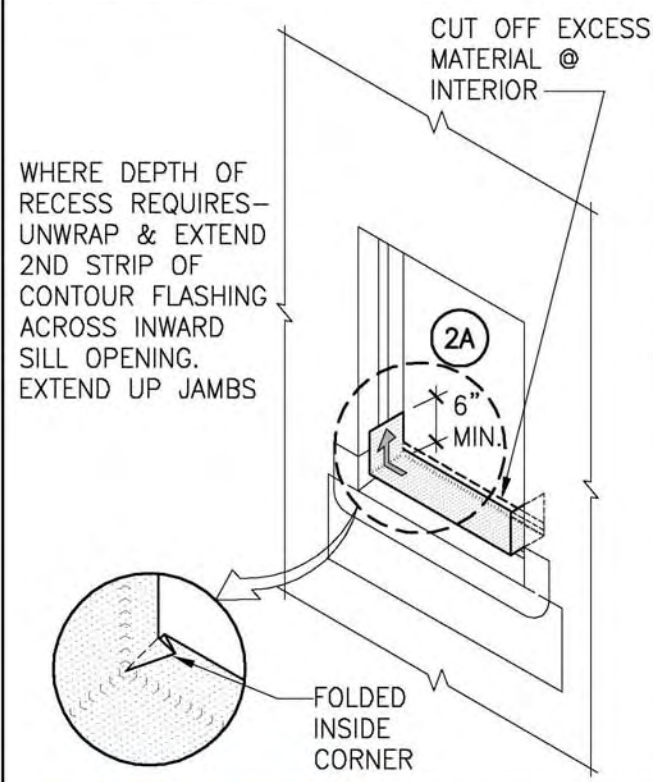

WHERE DEPTH OF
 RECESS REQUIRES—
 UNWRAP & EXTEND
 2ND STRIP OF
 CONTOUR FLASHING
 ACROSS INWARD
 SILL OPENING.
 EXTEND UP JAMBS

CUT OFF EXCESS
 MATERIAL @
 INTERIOR

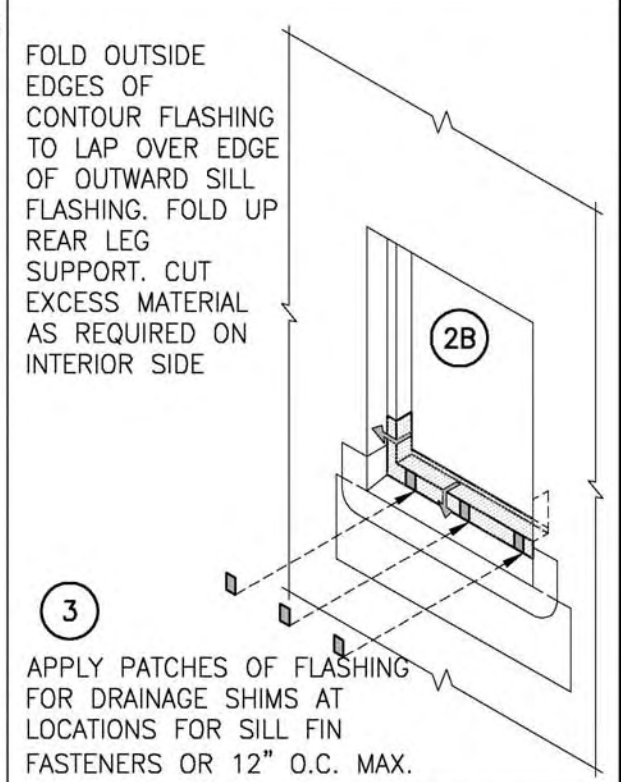

FOLD OUTSIDE
 EDGES OF
 CONTOUR FLASHING
 TO LAP OVER EDGE
 OF OUTWARD SILL
 FLASHING. FOLD UP
 REAR LEG
 SUPPORT. CUT
 EXCESS MATERIAL
 AS REQUIRED ON
 INTERIOR SIDE

3

APPLY PATCHES OF FLASHING
 FOR DRAINAGE SHIMS AT
 LOCATIONS FOR SILL FIN
 FASTENERS OR 12" O.C. MAX.



Project: RECESSED OPENING, BUILDING PAPER NAIL-FIN, STRAIGHT HEAD
 Title: CONTOUR WINDOW FLASHING, METHOD A

Drawing No.: RSB.2

:\\Projects\2006\067220-POLY\Drafting\Working_Set\Details\7.0_Contour Flashing Sequence Diagrams\POLY_Fig7.2_CRSB_01.dwg, 10/15/2007 3:20:04 PM, wtpowers

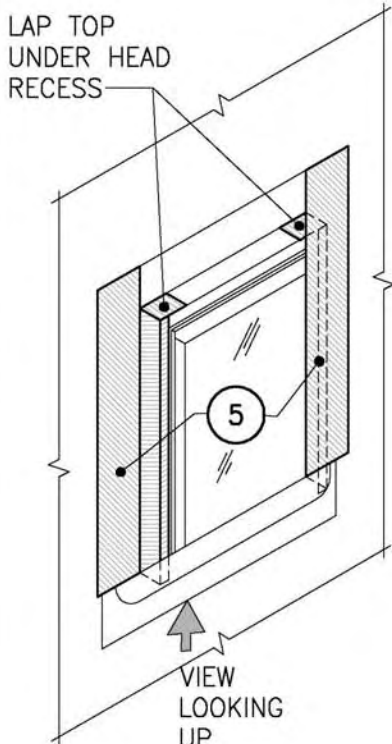
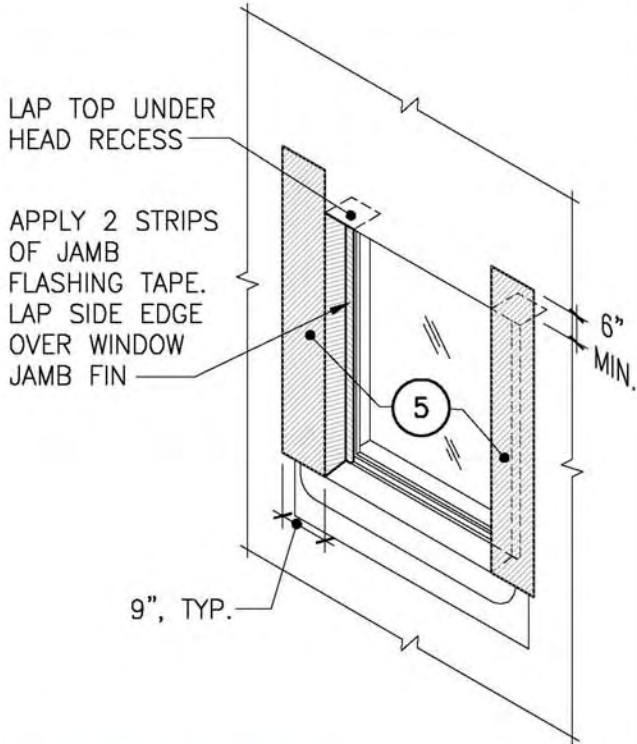
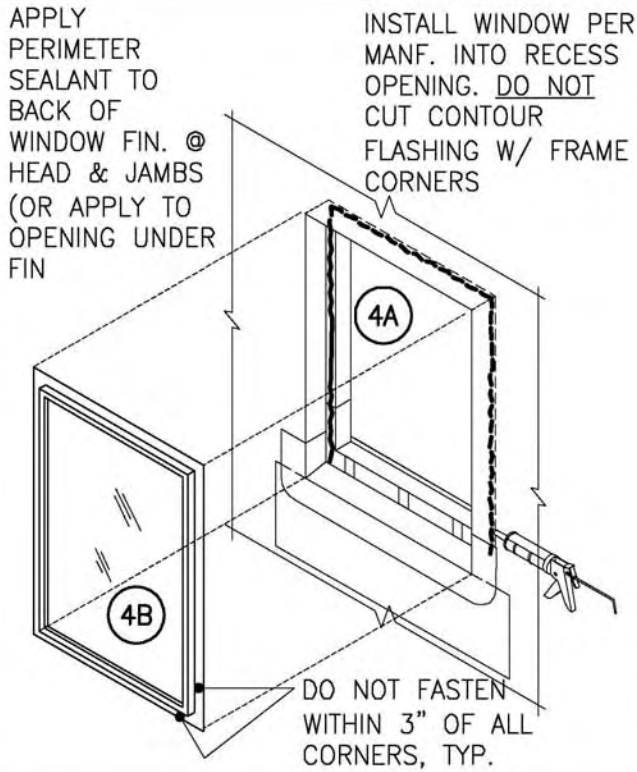

Project: RECESSED OPENING, BUILDING PAPER NAIL-FIN, STRAIGHT HEAD

Title: CONTOUR WINDOW FLASHING, METHOD A

Drawing No.: RSB.3

:Projects\2006\067220-POL\Y\Drafting\Working_Set_Details\7.0_Contour Flashing Sequence Diagrams\POL_Y_Fig7.2_CRSB_01.dwg, 10/15/2007 3:20:05 PM, wtpowers

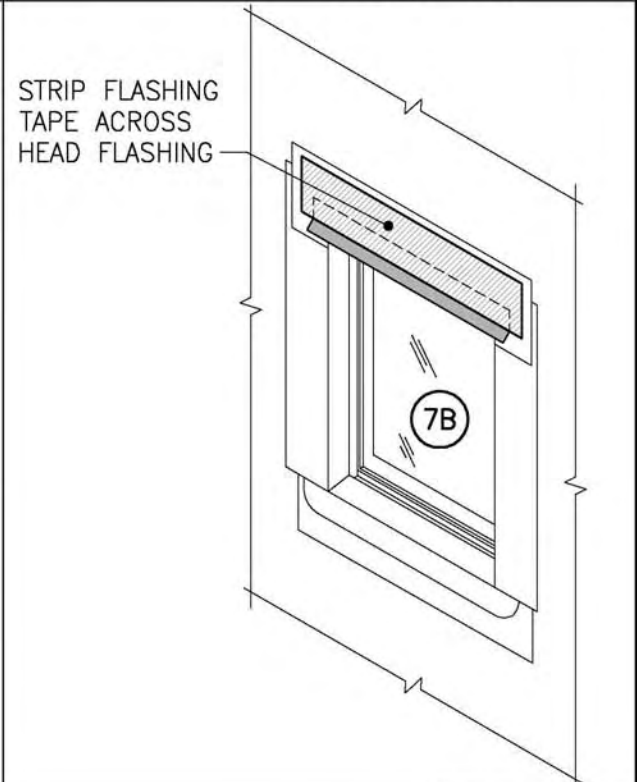
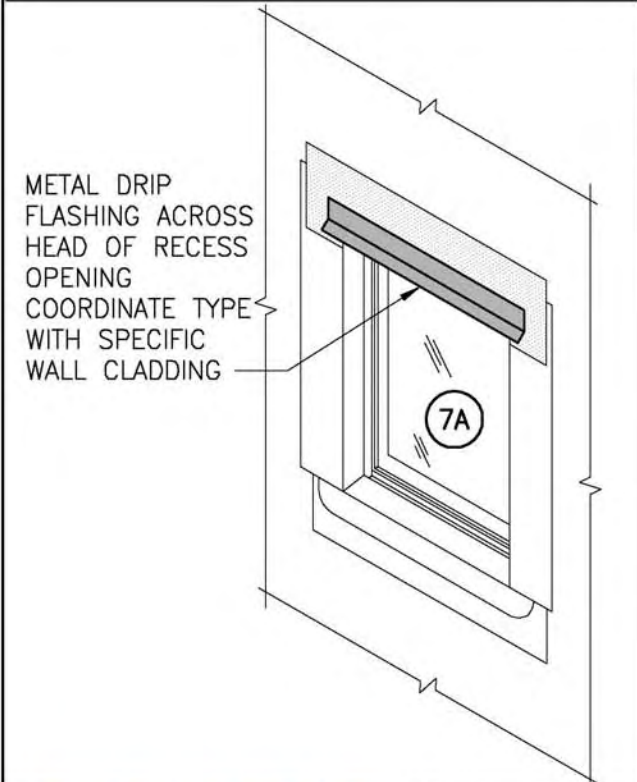
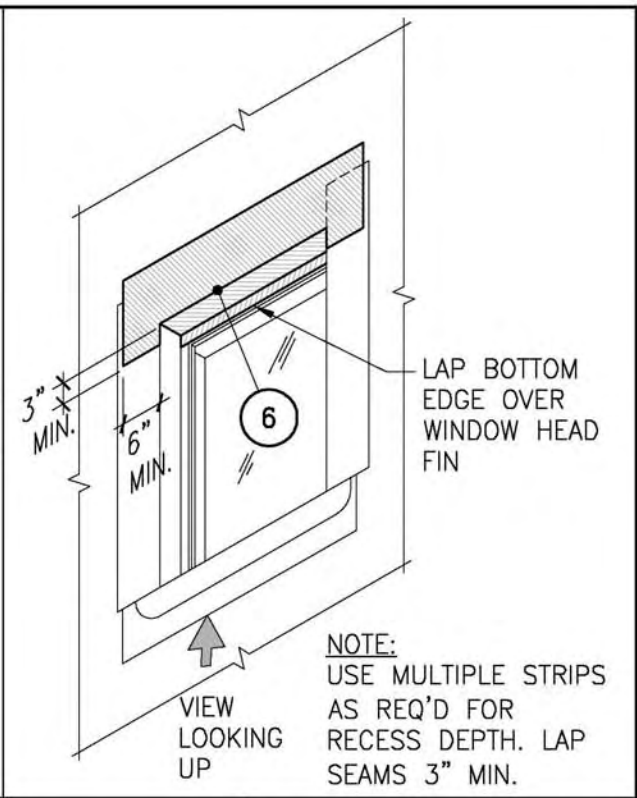
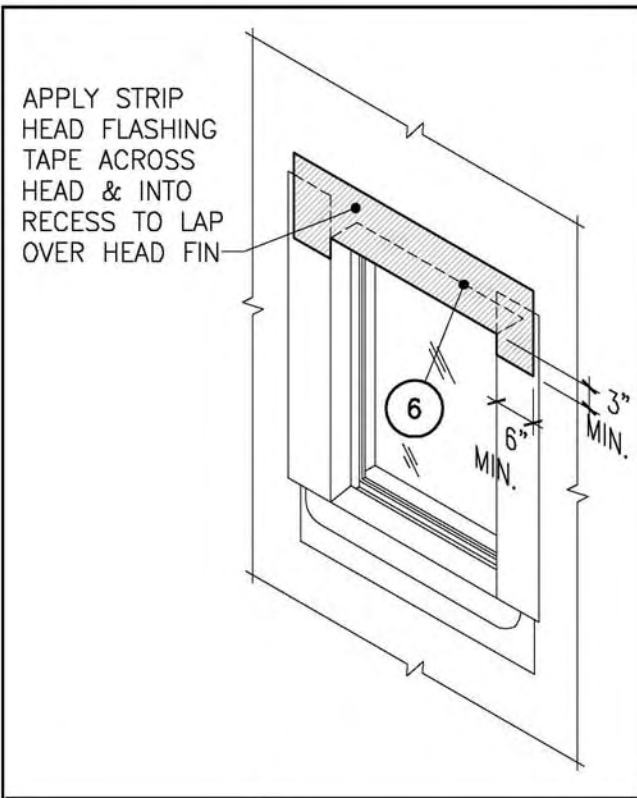

BERRYTM
PLASTICS
CORPORATION
AND SUBSIDIARIES
TAPES AND COATINGS DIVISION

Project:
RECESSED OPENING, BUILDING PAPER
NAIL-FIN, STRAIGHT HEAD

Title:
CONTOUR WINDOW FLASHING, METHOD A

Drawing No:
RSB.4

:\Projects\2006\067220-POL\Y\Drafting\Working_Set\Details\7.0_Contour Flashing Sequence Diagrams\POL_Y_Fig7.2_CRSB_01.dwg, 10/15/2007 3:20:05 PM, wtpowers

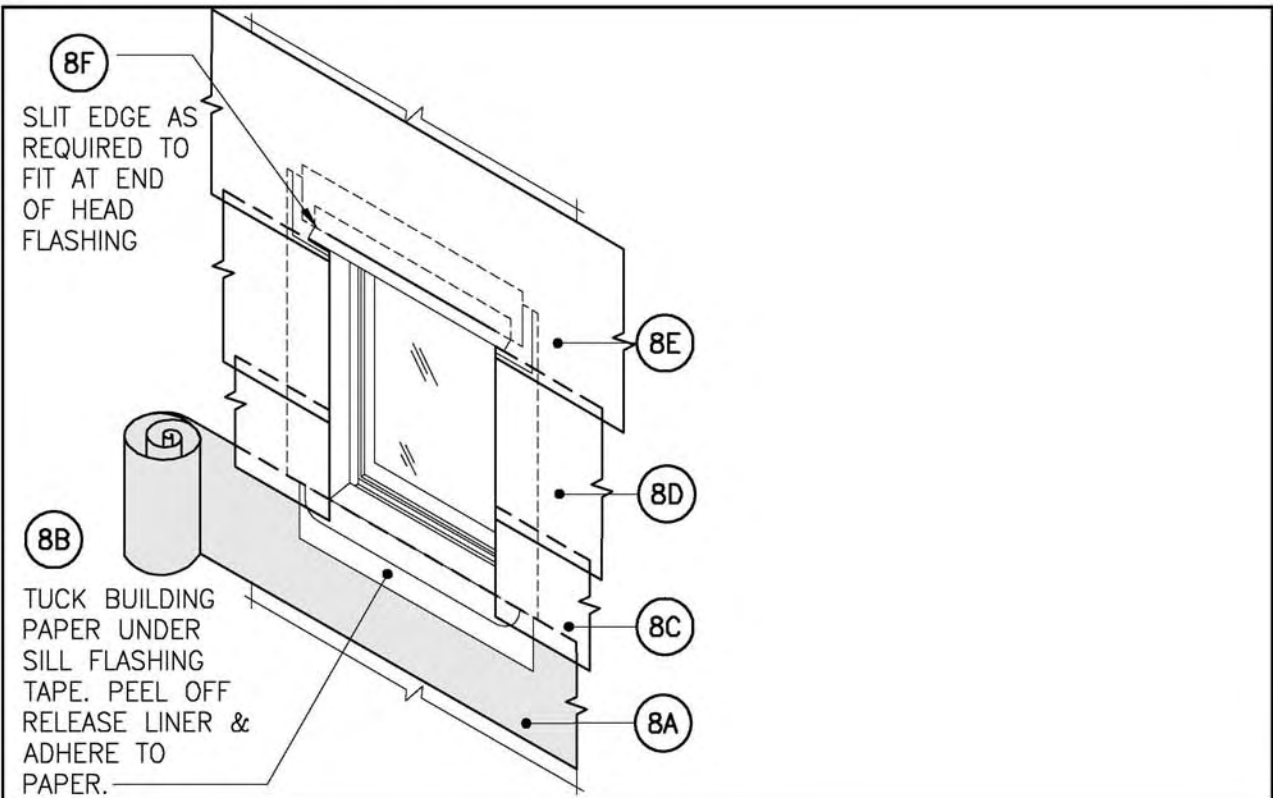

Project:
RECESSED OPENING, BUILDING PAPER
NAIL-FIN, STRAIGHT HEAD

Title:
CONTOUR WINDOW FLASHING, METHOD A

Drawing No:
RSB.5

:\Projects\2006\067220-POLY\Drafting\Working_Set\Details\7.0_Contour Flashing Sequence Diagrams\POLY_Fig-7.3_CRAH.dwg, 10/15/2007 3:20:07 PM, wpmwiers

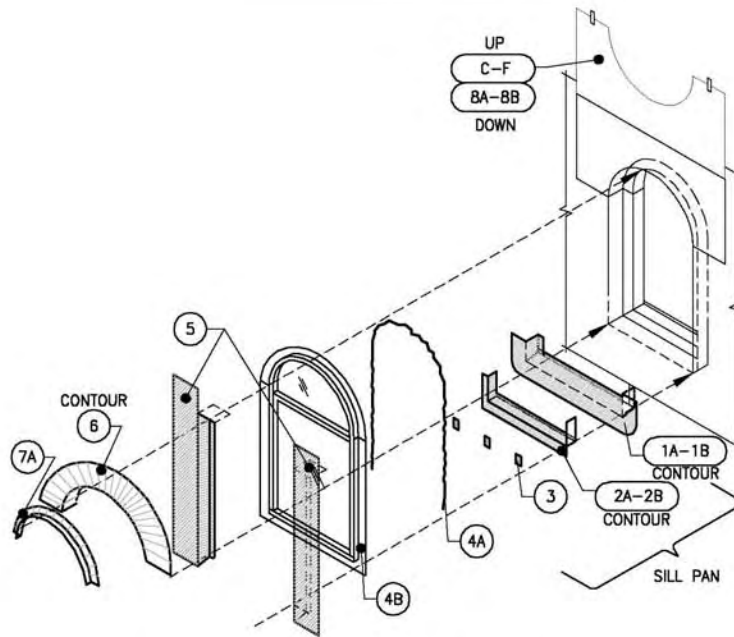

FLASHING SEQUENCE ① - ⑧

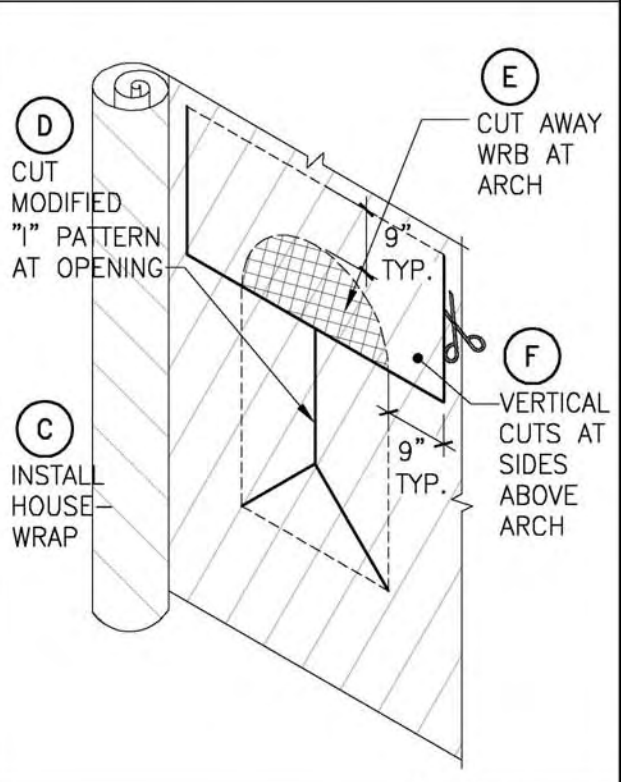
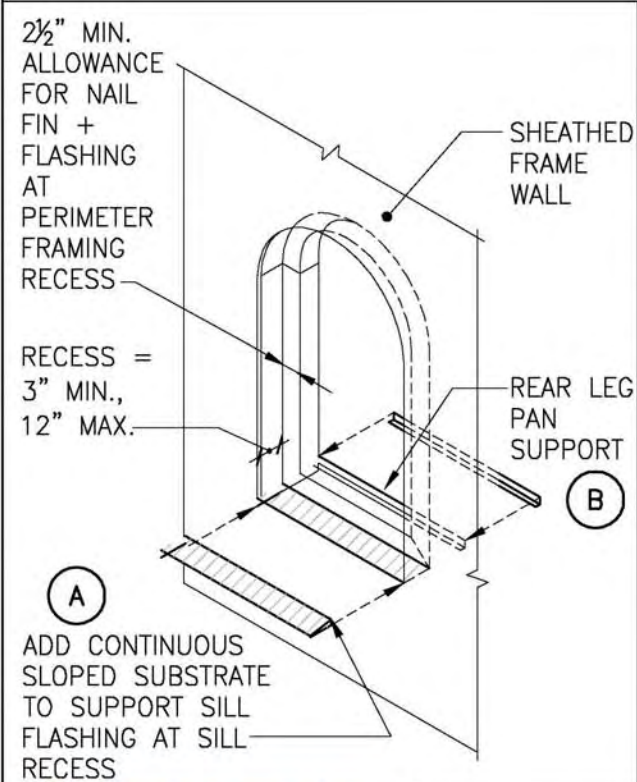

Project: RECESSED OPENING, HOUSEWRAP NAIL-FIN, ARCHED HEAD
 Title: CONTOUR: ARCH WINDOW, METHOD A1

Drawing No.: RAH.1

I:\Projects\2006\067220-POLY\Drafting\Working_Set\Details\7.0_Contour Flashing Sequence Diagrams\POLY_Fig-7.3_CRAH.dwg, 10/15/2007 3:20:08 PM, wprovers

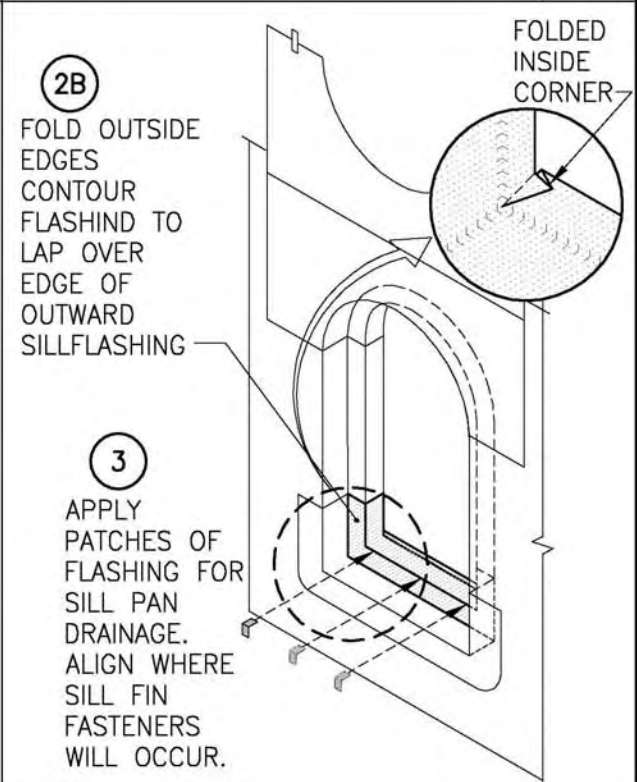
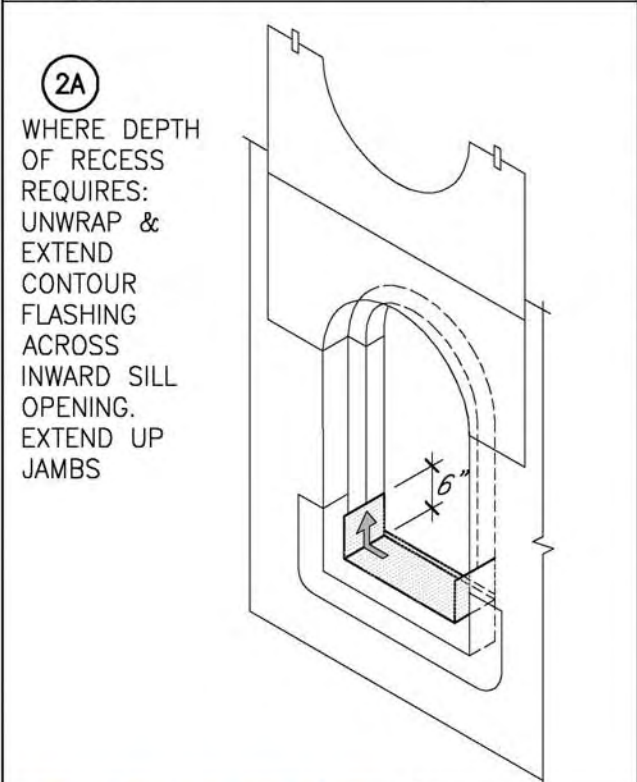
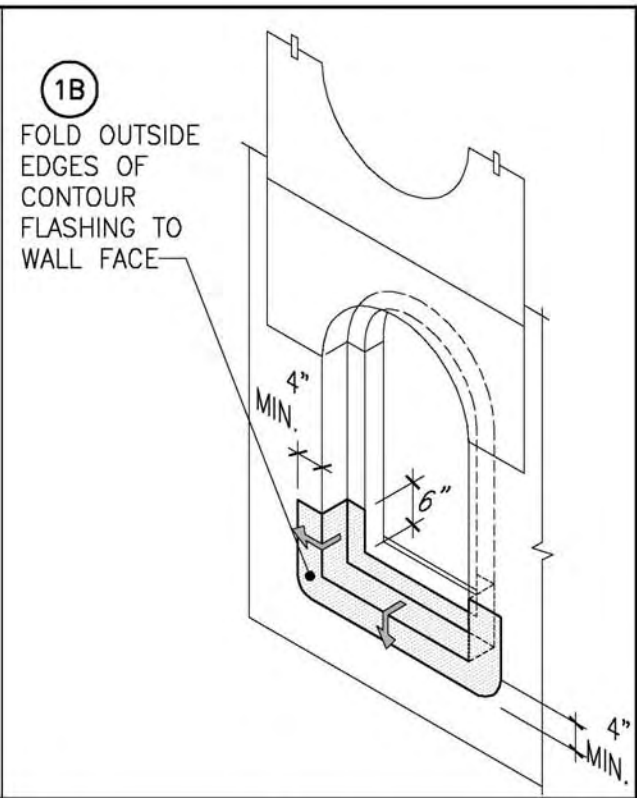
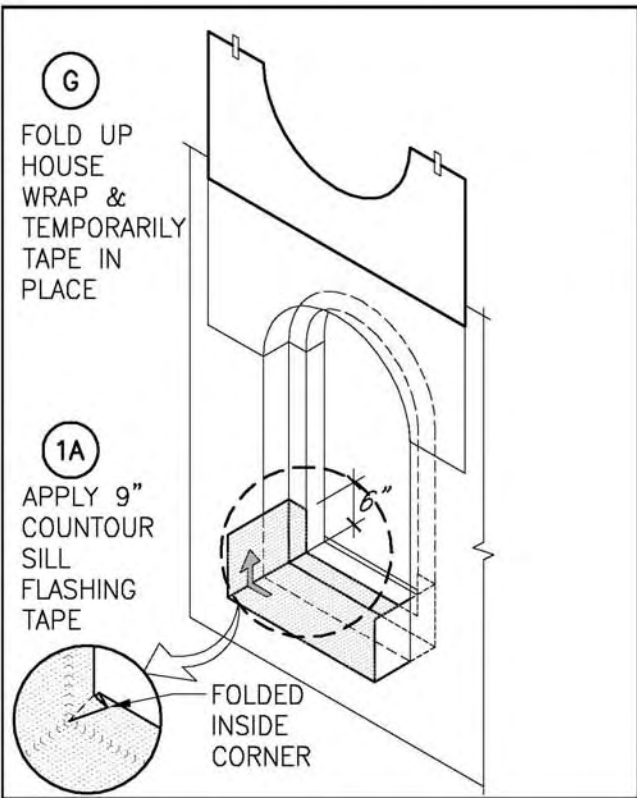

BERRY[™]
 PLASTICS CORPORATION
 AND SUBSIDIARIES
 TAPES AND COATINGS DIVISION

Project: RECESSED OPENING, HOUSEWRAP NAIL-FIN, ARCHED HEAD

Title: CONTOUR: ARCH WINDOW, METHOD A1

Drawing No: **RAH.2**

:\Projects\2006\067220-POLY\Drafting\Working_Set\Details\7.0_Contour Flashing Sequence Diagrams\POLY_Fig-7.3_CRAH.dwg, 10/15/2007 3:20:08 PM, wprovers

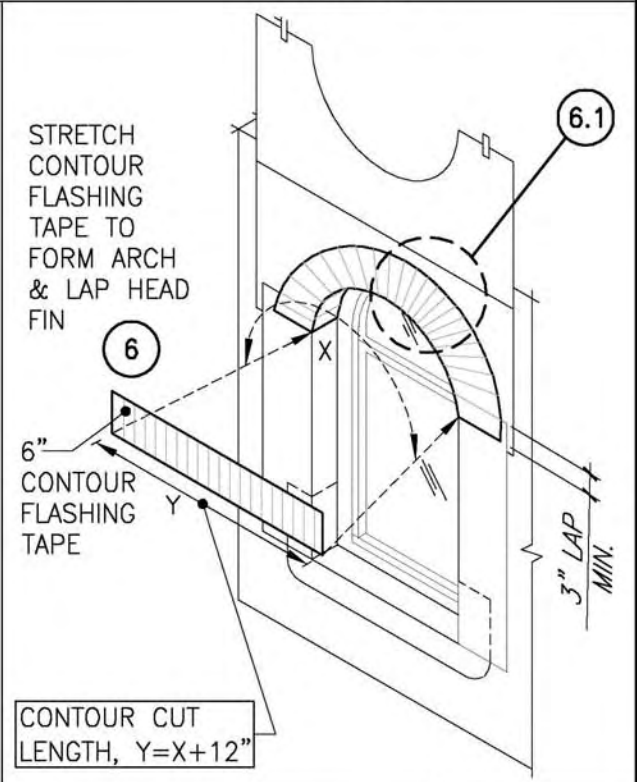
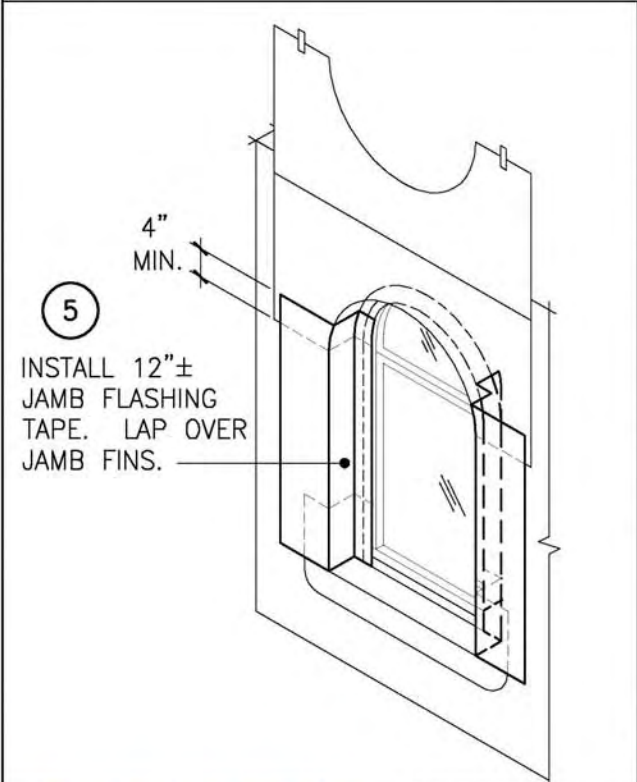
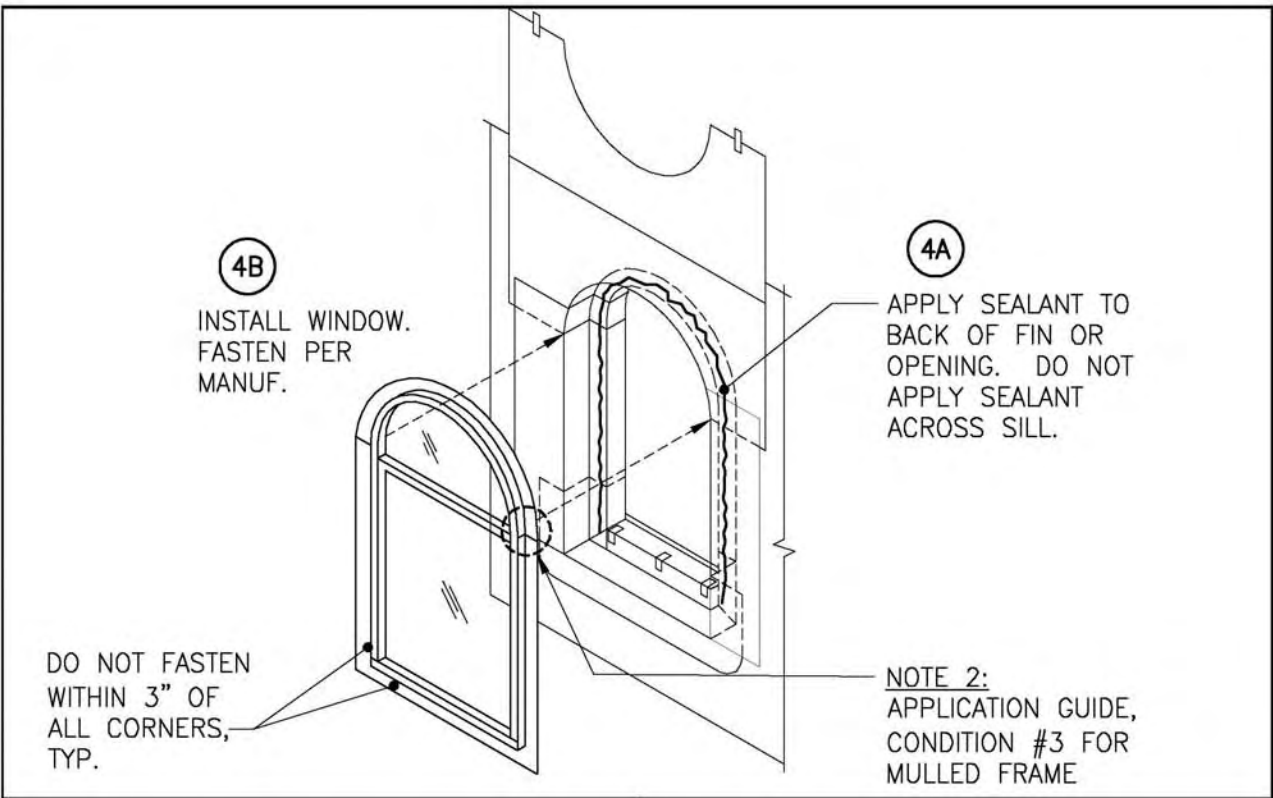

BERRY
PLASTICS CORPORATION
AND SUBSIDIARIES
TAPES AND COATINGS DIVISION

Project:
RECESSED OPENING, HOUSEWRAP NAIL-FIN, ARCHED HEAD

Title:
CONTOUR: ARCH WINDOW, METHOD A1

Drawing No.:
RAH.3

:\Projects\2006\067220-POLY\Drafting\Working_Set\Details\7.0_Contour Flashing Sequence Diagrams\POLY_Fig-7.3_CRAH.dwg, 10/15/2007 3:20:09 PM, wprovers

6.1 CONTOUR FLASHING CAN CONFORM TO ARCH

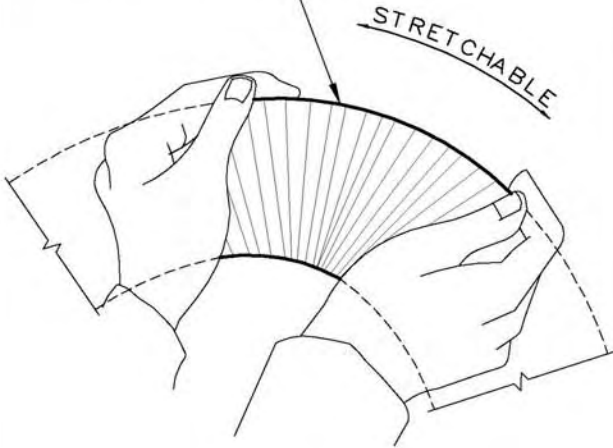

SUPPLEMENTAL HEAD FLASHING AT OPENING RECESS AS REQUIRED FOR EXTERIOR WALL CLADDING TYPE

7

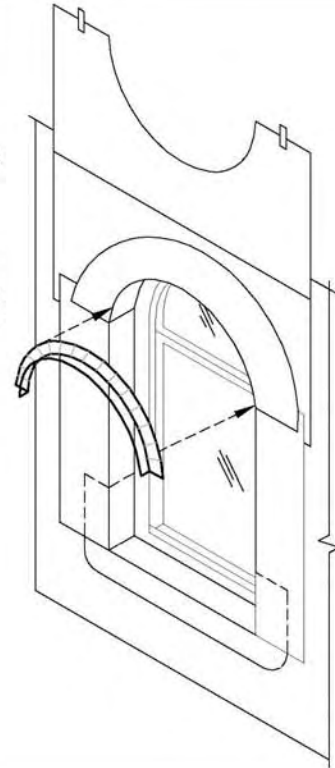

8A

FOLD DOWN WRB FLAP AT HEAD

8B

APPLY 4" FLASHING TAPE OVER SEAMS OF FOLDED DOWN FLAP

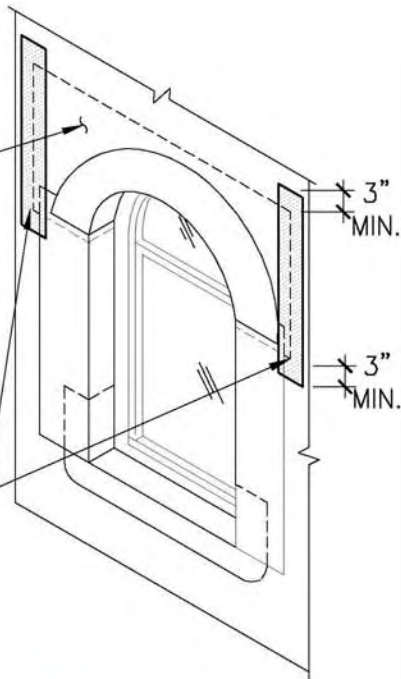

Project:

RECESSED OPENING, HOUSEWRAP NAIL-FIN, ARCHED HEAD

Title:

CONTOUR: ARCH WINDOW, METHOD A1

Drawing No.:

RAH.4

I:\Projects\2006\067220-POLY\Drafting\Working_Set\Details\7.0_Contour Flashing Sequence Diagrams\POLY_Fig-7.4_CRAB.dwg, 10/15/2007 3:20:11 PM, wprovers

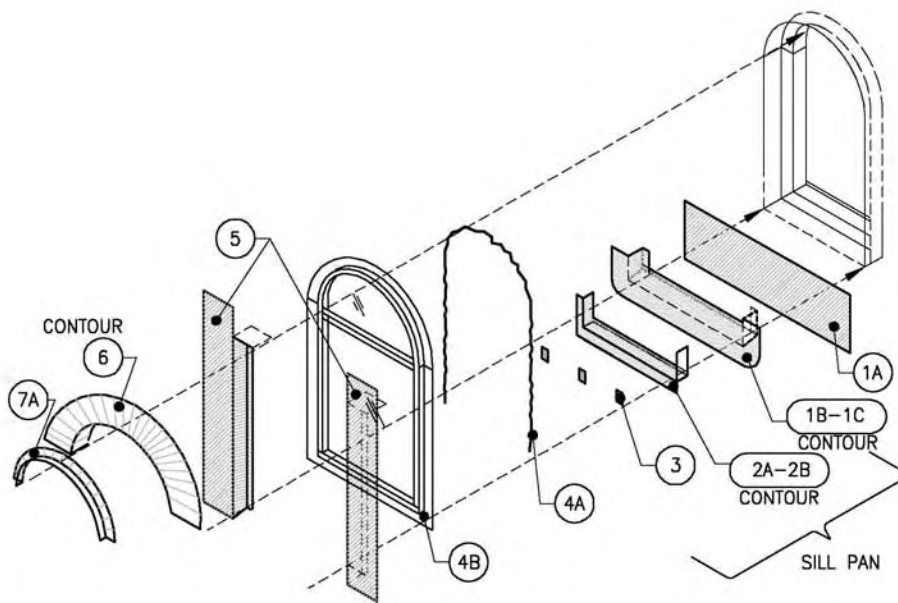

FLASHING SEQUENCE ① - ⑦, BUILDING PAPER ⑧

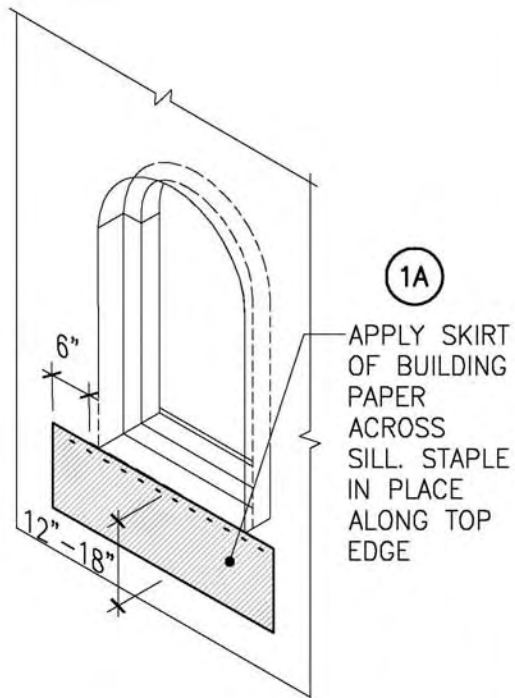
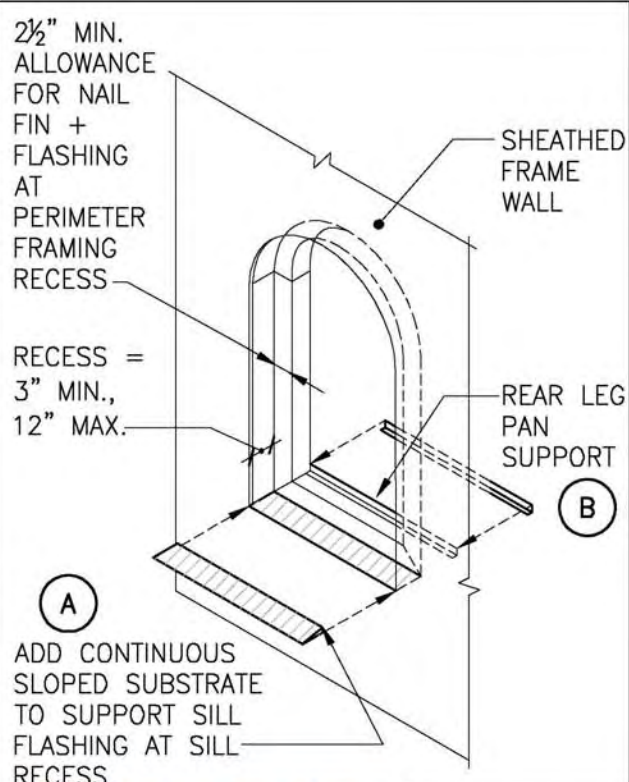

Project: RECESSED OPENING, HOUSEWRAP NAIL-FIN, ARCHED HEAD

Title: CONTOUR: ARCH WINDOW, METHOD A

Drawing No.: RAB.1

:\Projects\2006\067220-POLY\Drafting\Working_Set\Details\7.0_Contour Flashing Sequence Diagrams\POLY_Fig7.4_CRAB.dwg, 10/15/2007 3:20:12 PM, wprovers

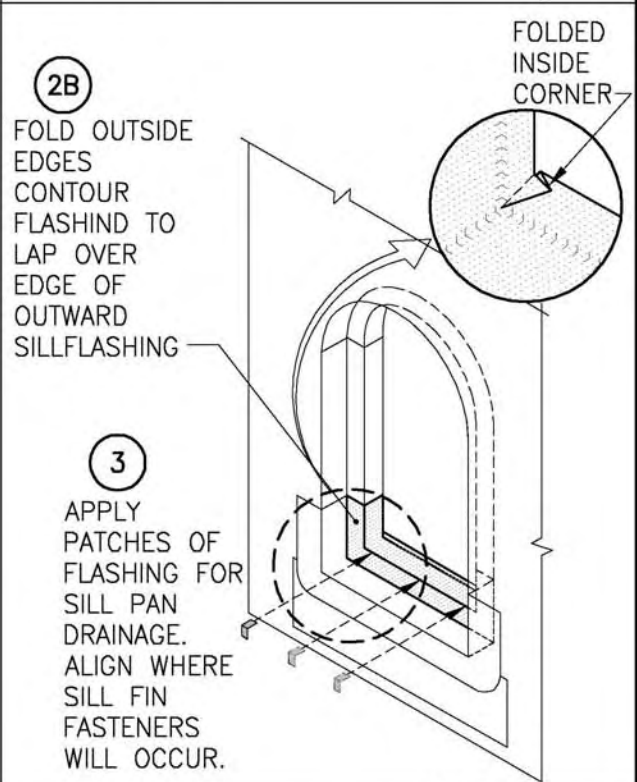
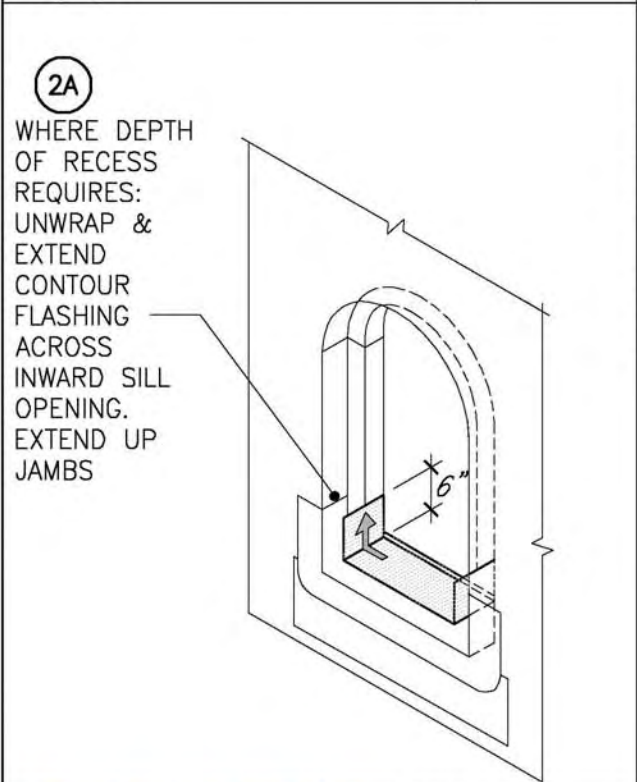
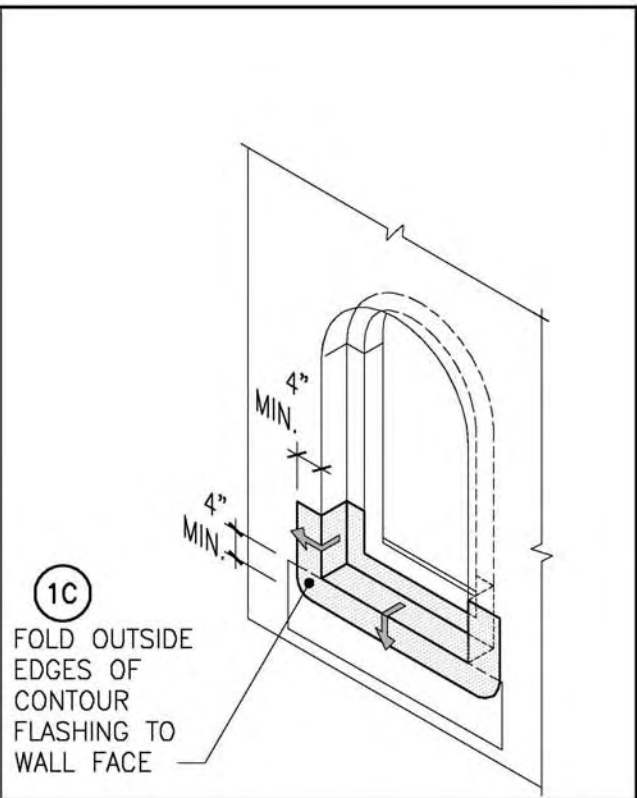
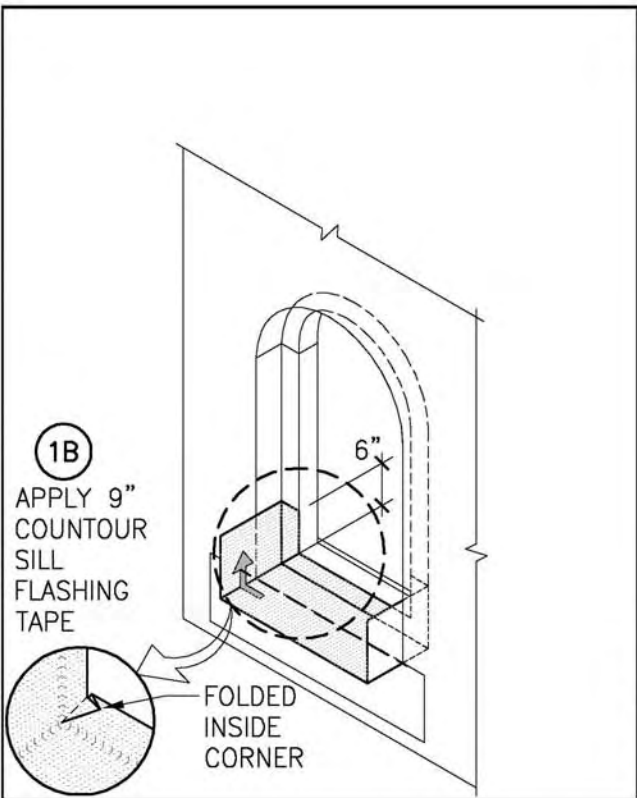

BERRY
PLASTICS CORPORATION
AND SUBSIDIARIES
TAPES AND COATINGS DIVISION

Project: RECESSED OPENING, HOUSEWRAP NAIL-FIN, ARCHED HEAD

Title: CONTOUR: ARCH WINDOW, METHOD A

Drawing No: **RAB.2**

I:\Projects\2006\067220-POLY\Drafting\Working_Set\Details\7.0_Contour Flashing Sequence Diagrams\POLY_Fig7.4_CRAB.dwg, 10/15/2007 3:20:12 PM, wprovers

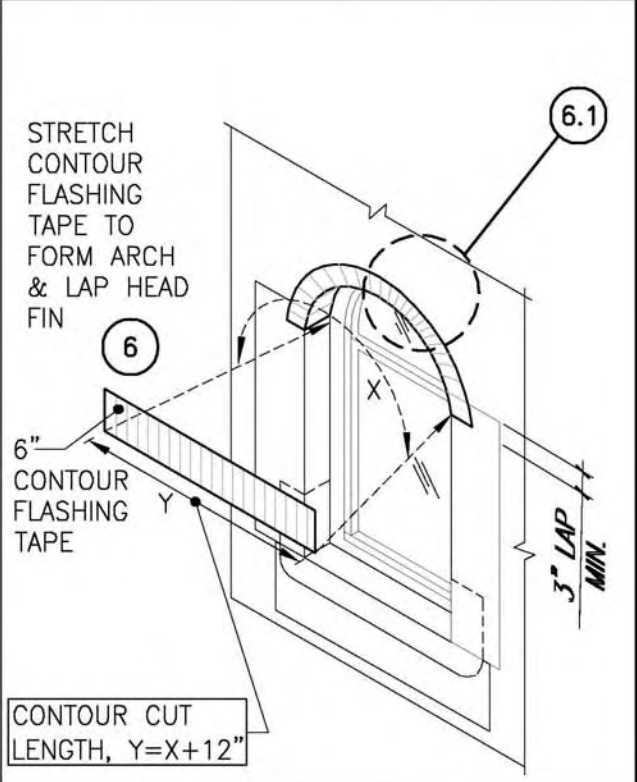
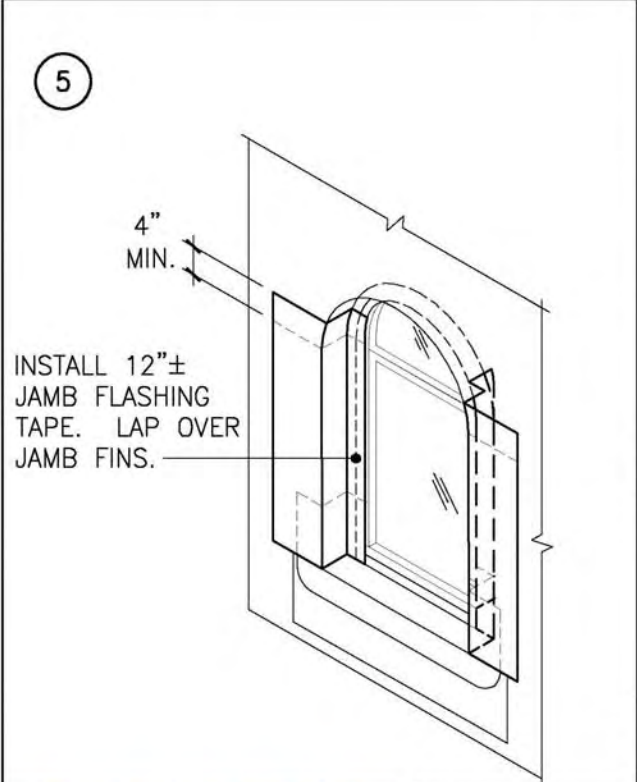
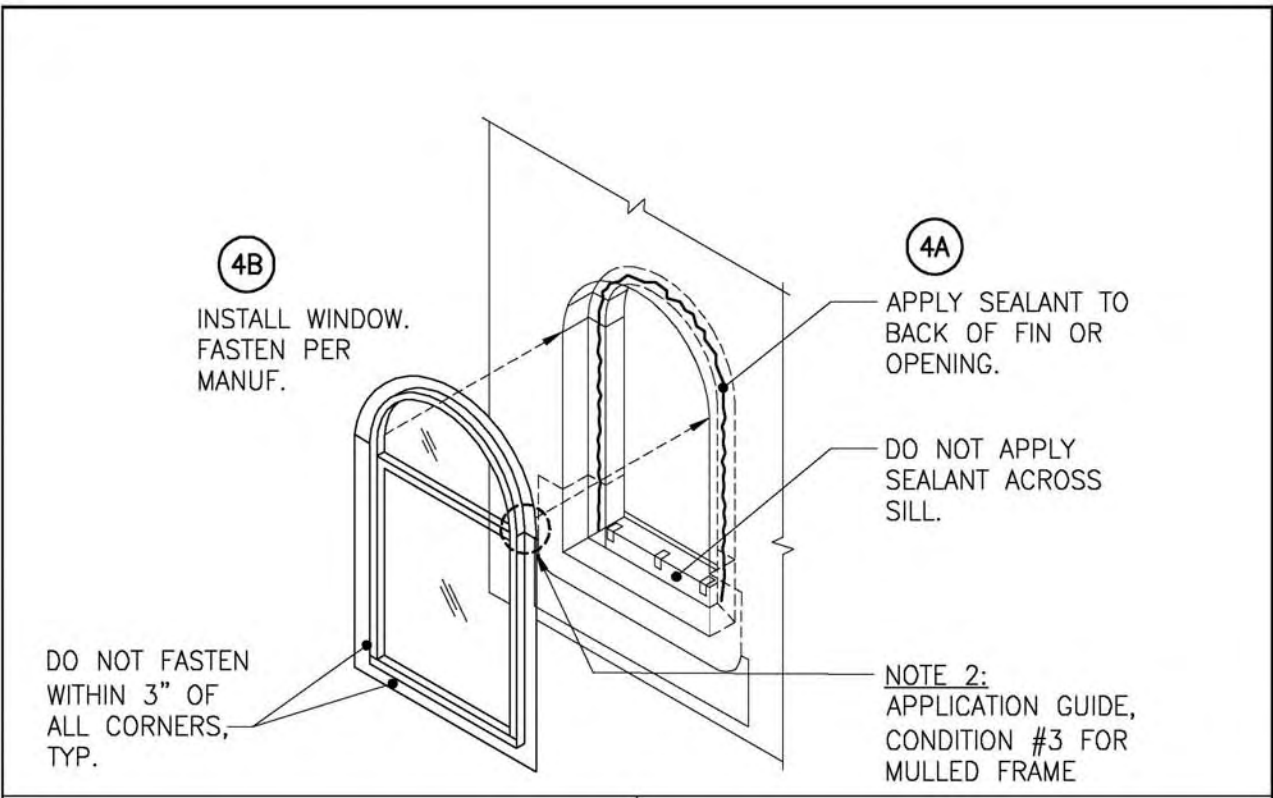

Project:
 RECESSED OPENING, HOUSEWRAP NAIL-FIN, ARCHED HEAD

Title:
 CONTOUR: ARCH WINDOW, METHOD A

Drawing No.:
RAB.3

I:\Projects\2006\067220-POLY\Drafting\Working_Set\Details\7.0_Contour Flashing Sequence Diagrams\POLY_Fig7.4_CRAB.dwg, 10/15/2007 3:20:13 PM, wfpowers

6.1 CONTOUR FLASHING CAN CONFORM TO ARCH

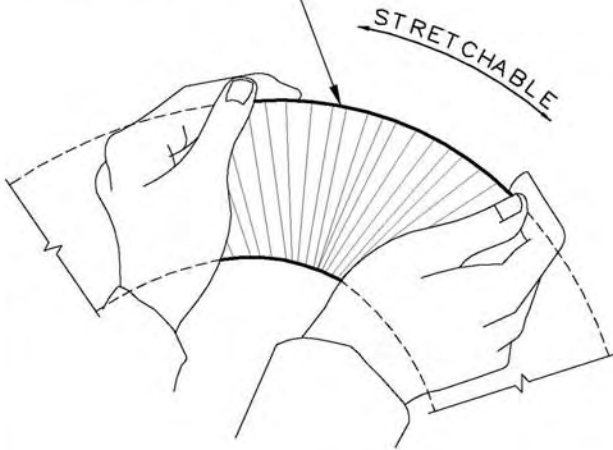

SUPPLEMENTAL HEAD FLASHING AT OPENING RECESS AS REQUIRED FOR EXTERIOR WALL CLADDING TYPE

7A

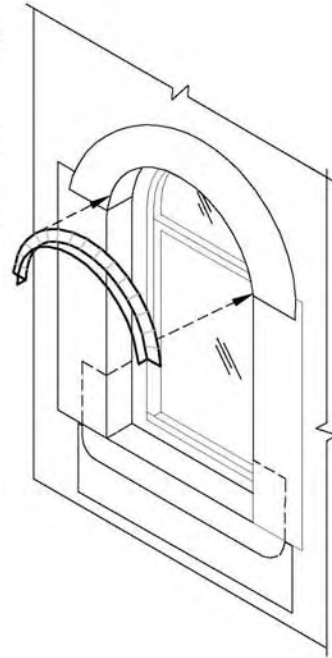

STRETCH CONTOUR FLASHING TAPE TO FORM ARCH & LAP HEAD FLASHING LEG

7B

6" CONTOUR FLASHING TAPE

CONTOUR CUT LENGTH, $Y = X + 12"$

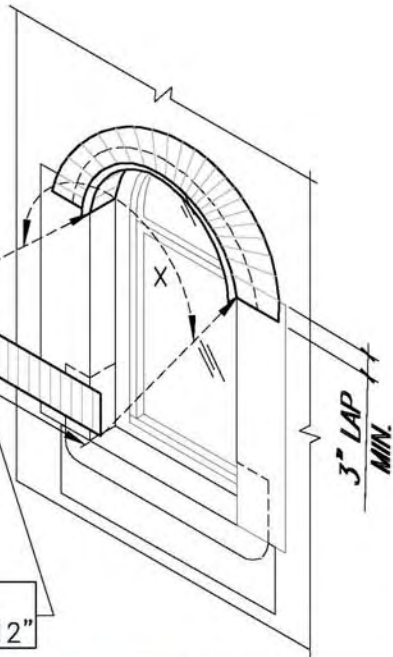

CUT AWAY BUILDING PAPER AT HEAD ARCH

8E

8D

8C

8B

8A

TUCK BUILDING PAPER UNDER SILL FLASHING TAPE. PEEL OFF RELEASE LINER & ADHERE TO PAPER.

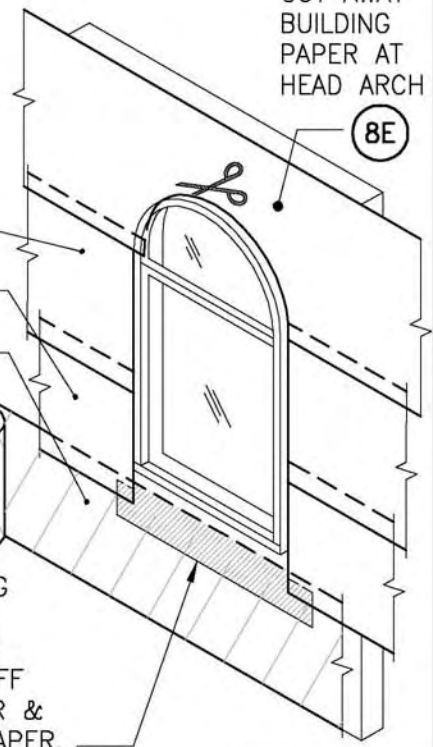

Project: RECESSED OPENING, HOUSEWRAP NAIL-FIN, ARCHED HEAD

Title: CONTOUR: ARCH WINDOW, METHOD A

Drawing No.: RAB.4

:Projects\2006\067220-POLY\Drafting\Working_Set_Details\7.0_Contour Flashing Sequence Diagrams\POLY_Fig-7.5_CFAH_01.dwg, 10/15/2007 3:20:15 PM, wtpowers

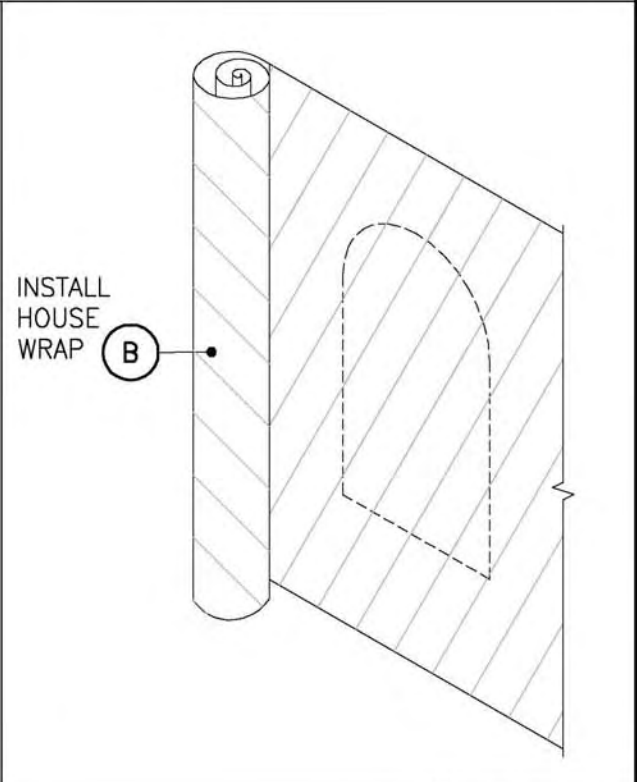
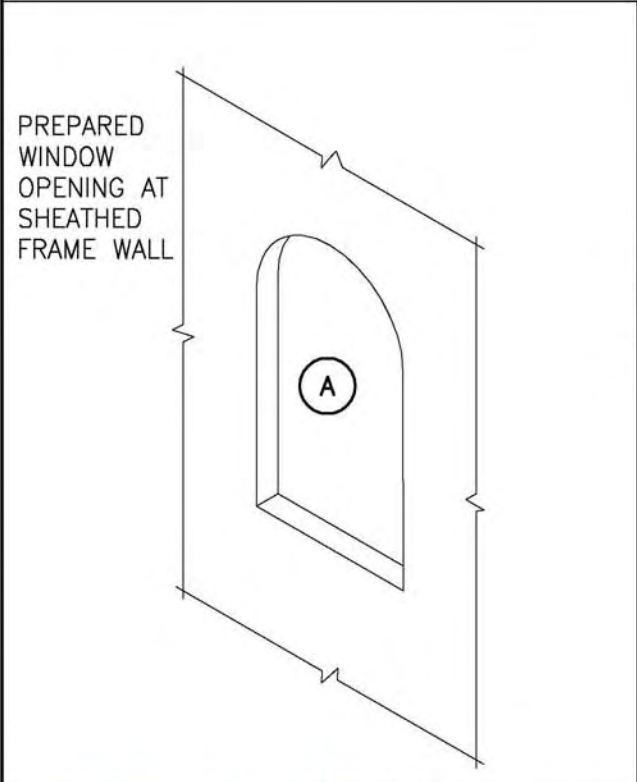
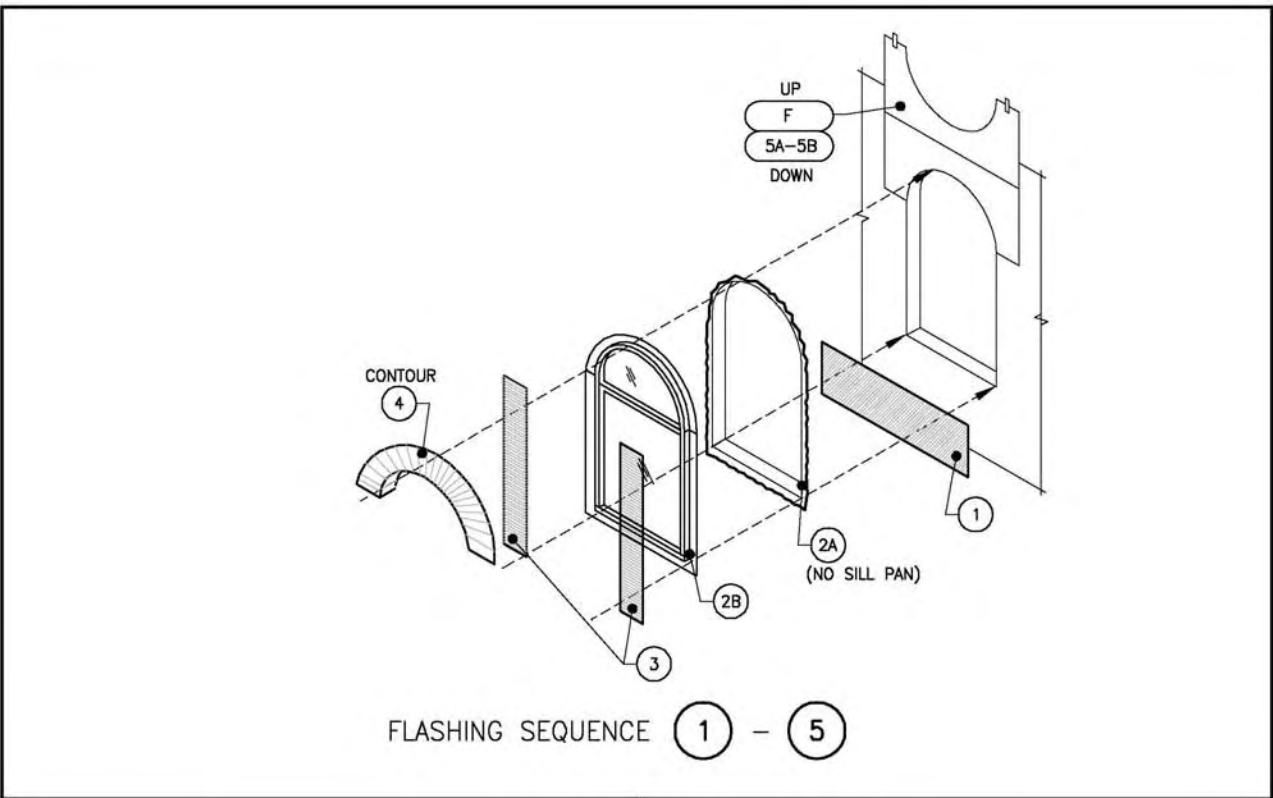

BERRY[™]
 PLASTICS CORPORATION
 AND SUBSIDIARIES
 TAPES AND COATINGS DIVISION

Project: FLUSH OPENING, HOUSEWRAP NAIL-FIN, ARCHED HEAD

Title: CONTOUR: ARCH WINDOW FLASHING, METHOD A1

Drawing No.: **FAH.1**

:\Projects\2006\067220-POLY\Drafting\Working_Set\Details\7.0_Contour Flashing Sequence Diagrams\POLY_Fig.7.5_CFAH.01.dwg, 10/15/2007 3:20:15 PM, wtpowers

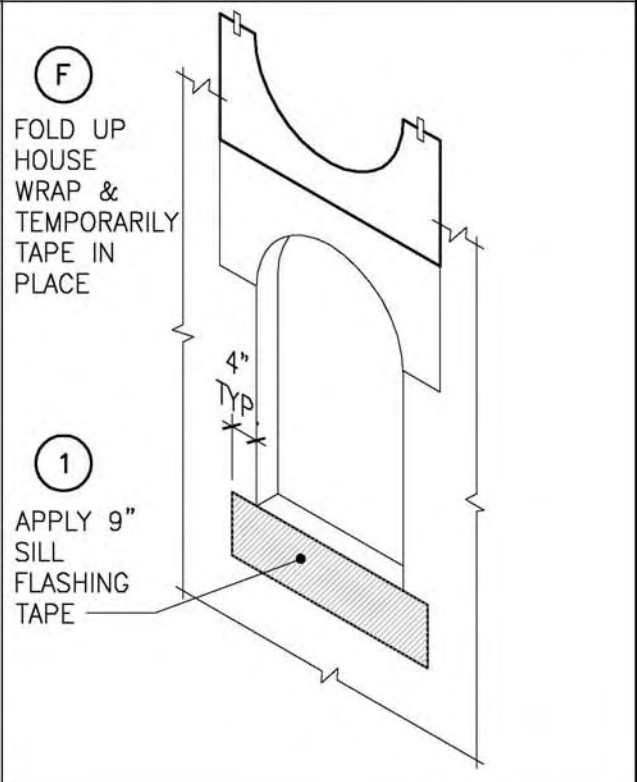
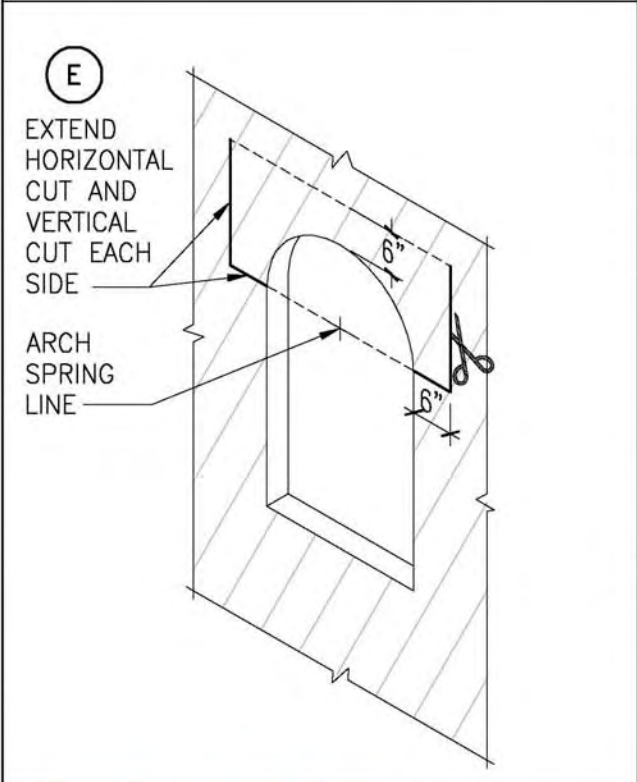
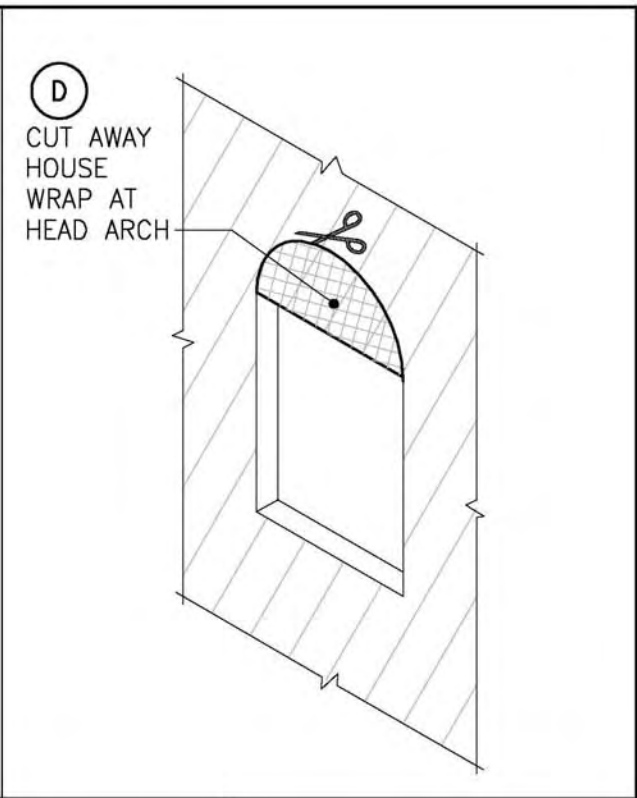
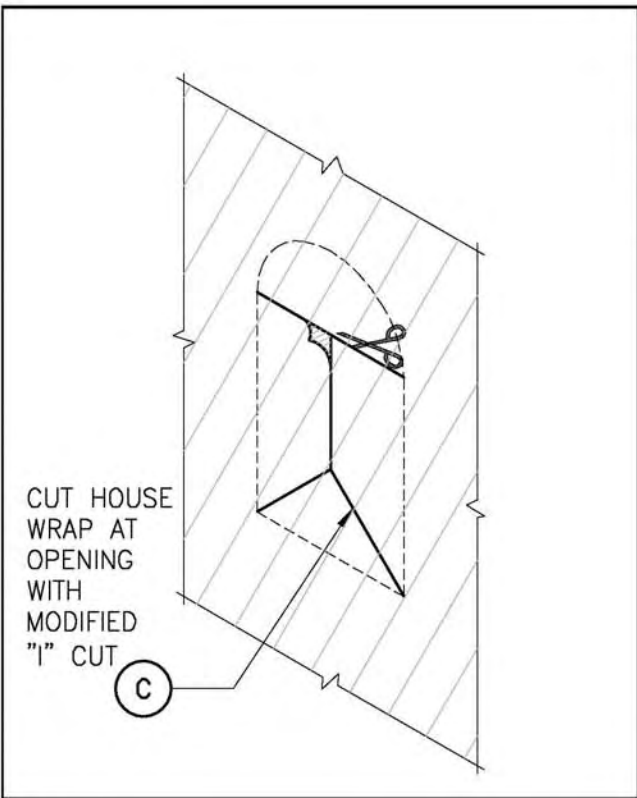

BERRY[™]
PLASTICS CORPORATION
AND SUBSIDIARIES
TAPES AND COATINGS DIVISION

Project: FLUSH OPENING, HOUSEWRAP NAIL-FIN, ARCHED HEAD

Title: CONTOUR: ARCH WINDOW FLASHING, METHOD A1

Drawing No.: FAH.2

I:\Projects\2006\067220-POLY\Drafting\Working_Set\Details\7.0_Contour Flashing Sequence Diagrams\POLY_Fig7.5_CFAH_01.dwg, 10/15/2007 3:20:16 PM, mtpowers

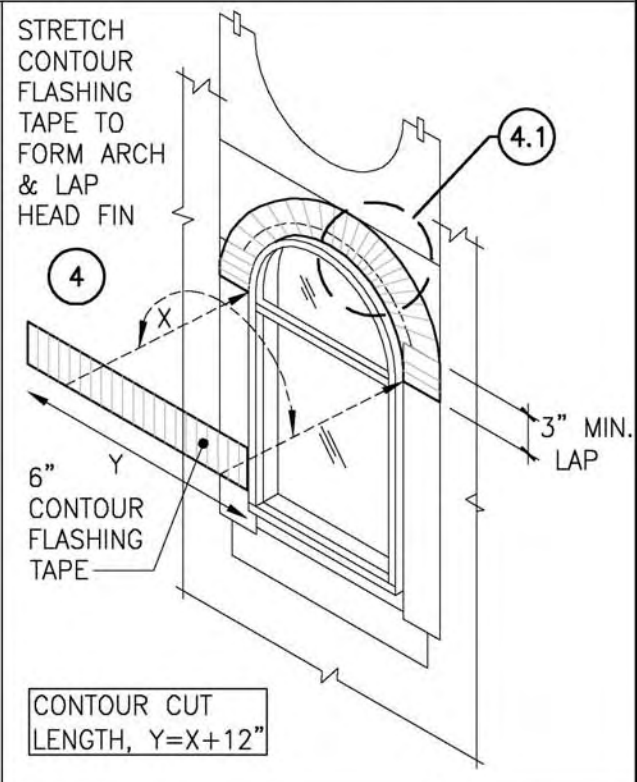
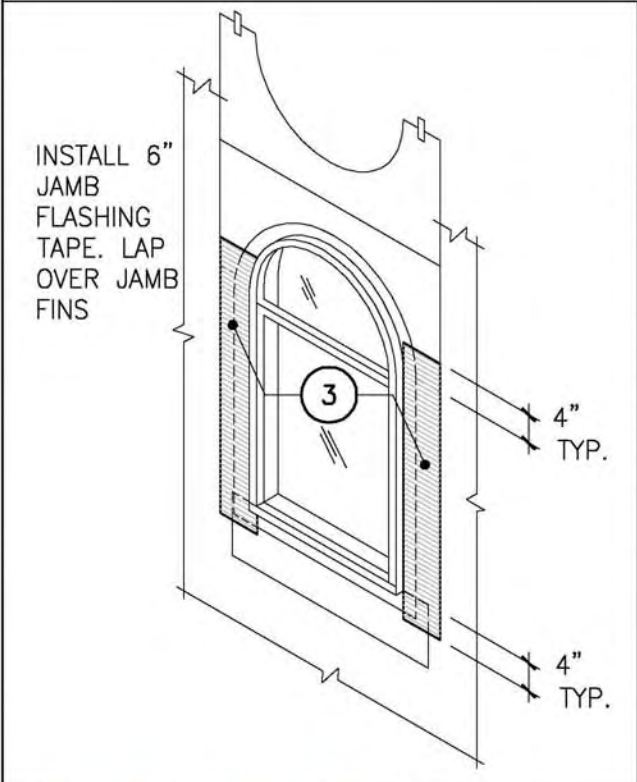
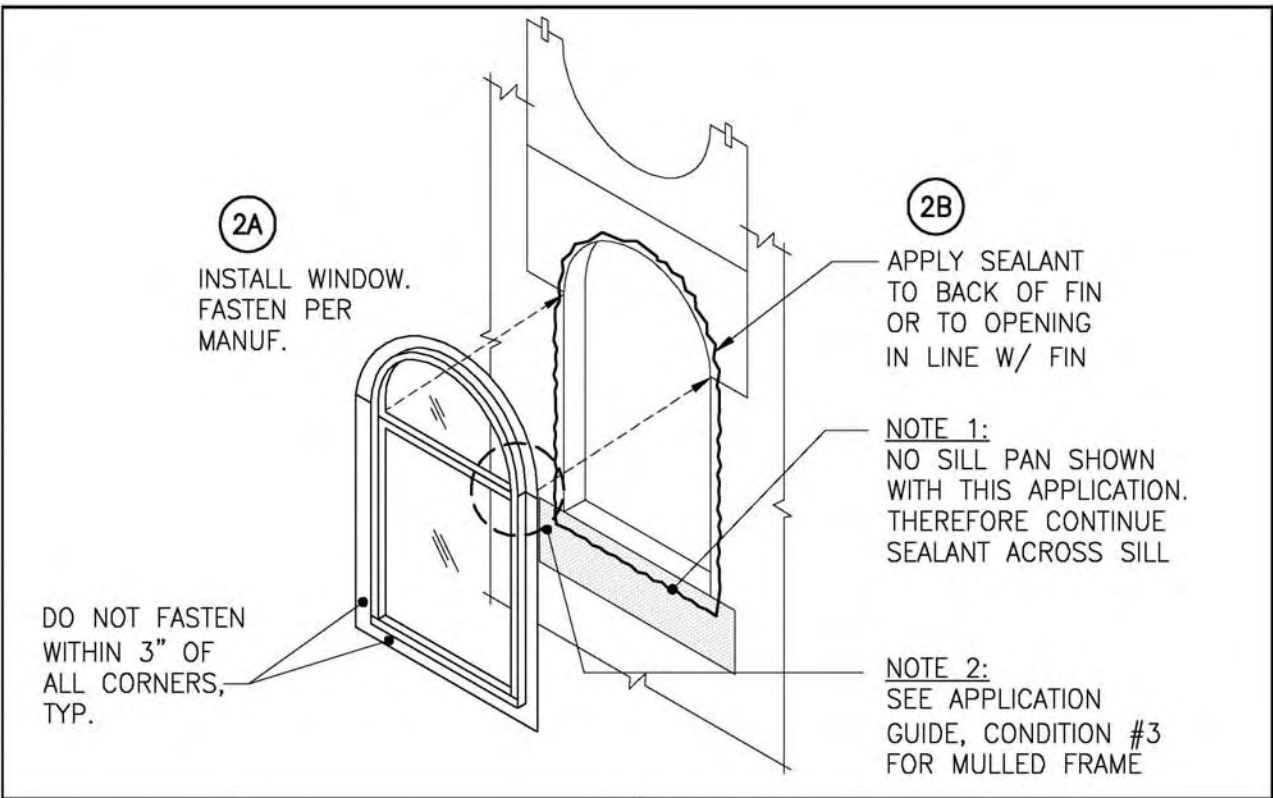

Project:
 FLUSH OPENING, HOUSEWRAP
 NAIL-FIN, ARCHED HEAD

Title:
 CONTOUR: ARCH WINDOW FLASHING, METHOD A1

Drawing No.:
FAH.3

:\Projects\2006\067220-POLY\Drafting\Working_Set\Details\7.0_Contour Flashing Sequence Diagrams\POLY_Fig-7.5_CFAH_01.dwg, 10/15/2007 3:20:16 PM, wtpowers

4.1 CONTOUR FLASHING CAN CONFORM TO ARCH

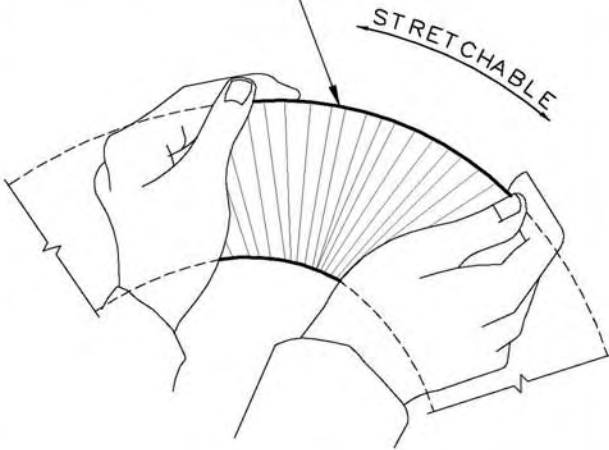

5A

FOLD DOWN HOUSE WRAP AT ARCH

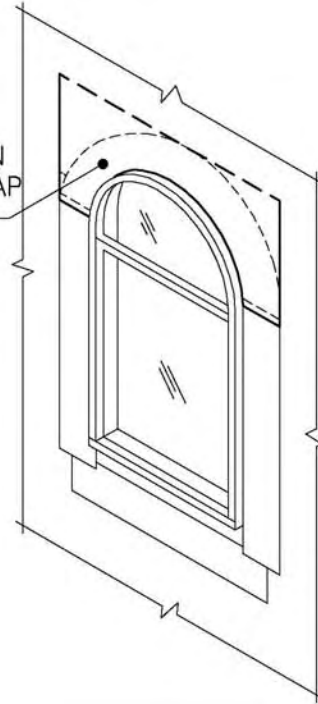

5B

APPLY 4" FLASHING TAPE OVER VERTICAL SEAMS EACH SIDE

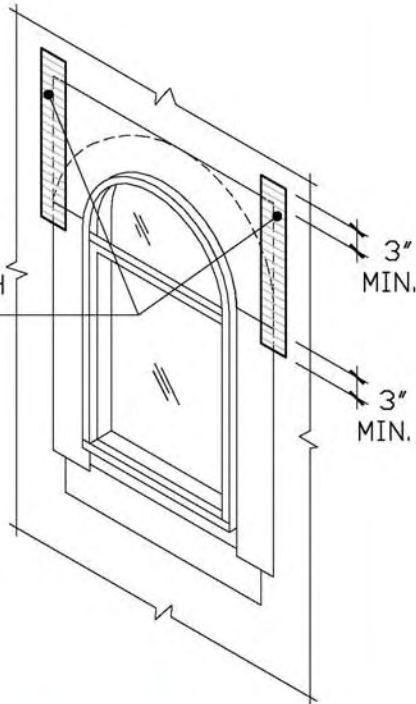

Project:

FLUSH OPENING, HOUSEWRAP NAIL-FIN, ARCHED HEAD

Title:

CONTOUR: ARCH WINDOW FLASHING, METHOD A1

Drawing No.:

FAH.4

:\Projects\2006\067220-POL\Y\Drafting\Working_Set\Details\7.0_Contour Flashing Sequence Diagrams\POLY_Fig-7.6_CFA8_01.dwg, 10/15/2007 3:20:00 PM, wfpowers

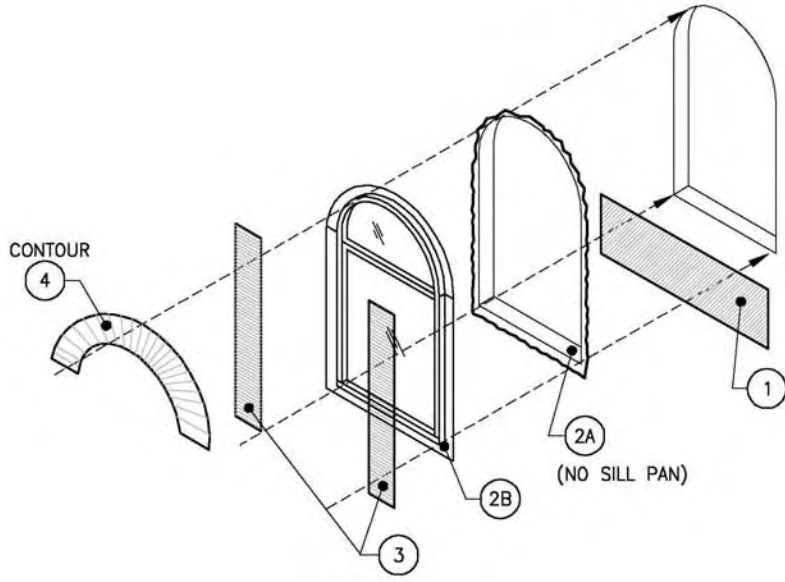

FLASHING SEQUENCE ① - ④, BUILDING PAPER ⑤

PREPARED WINDOW OPENING AT SHEATHED FRAME WALL

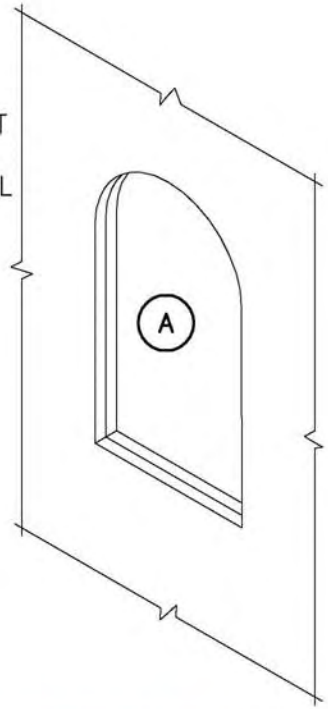

①

APPLY 9" SILL FLASHING TAPE. KEEP RELEASE LINER ON UNTIL STEP ⑤A

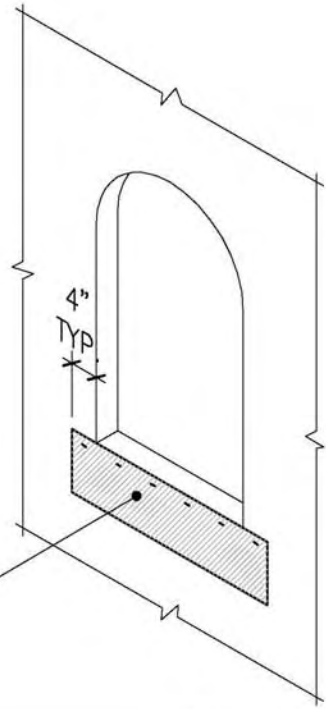

Project: FLUSH OPENING, BUILDING PAPER
NAIL-FIN, ARCHED HEAD
Title: CONTOUR: WINDOW FLASHING, METHOD A

Drawing No: FAB.1

:\Projects\2006\067220-POLY\Drafting\Working_Set\Details\7.0_Contour Flashing Sequence Diagrams\POLY_Fig7.6_CFAB_01.dwg, 10/15/2007 3:20:01 PM, mcpowers

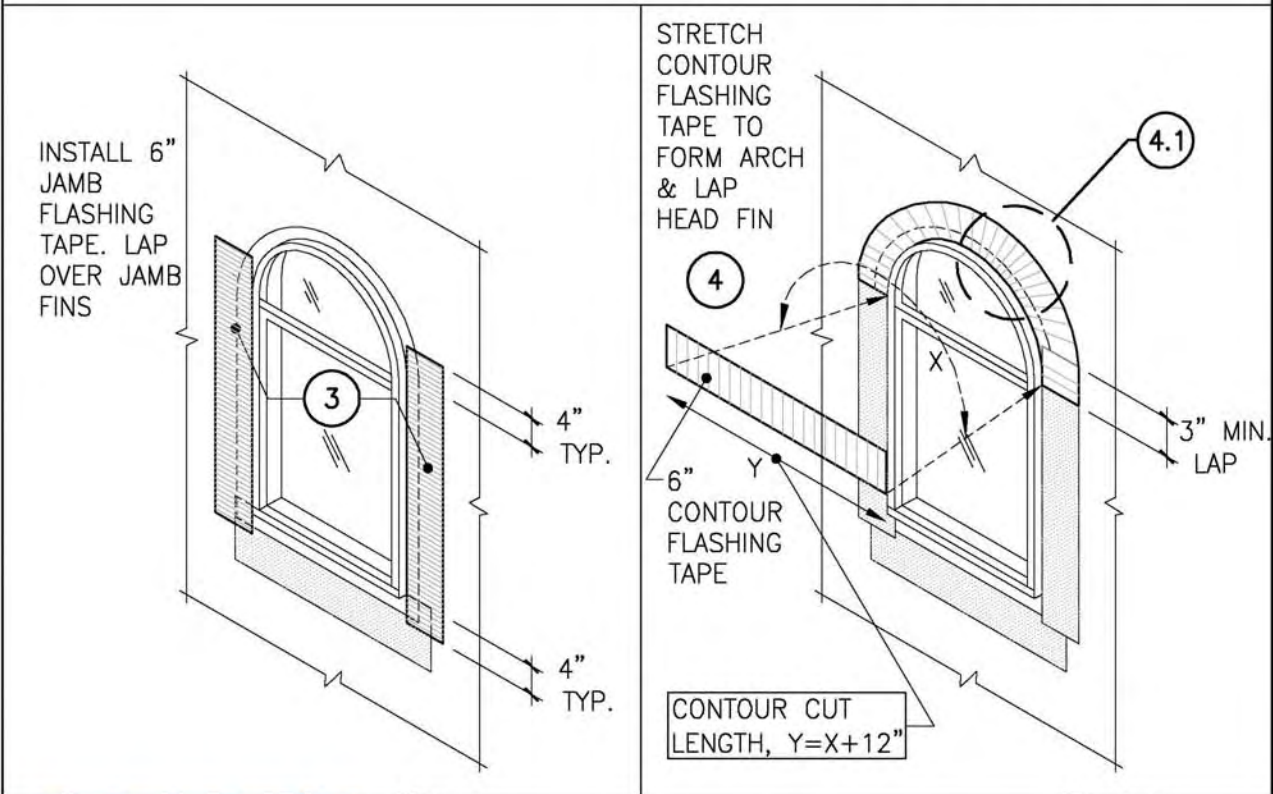
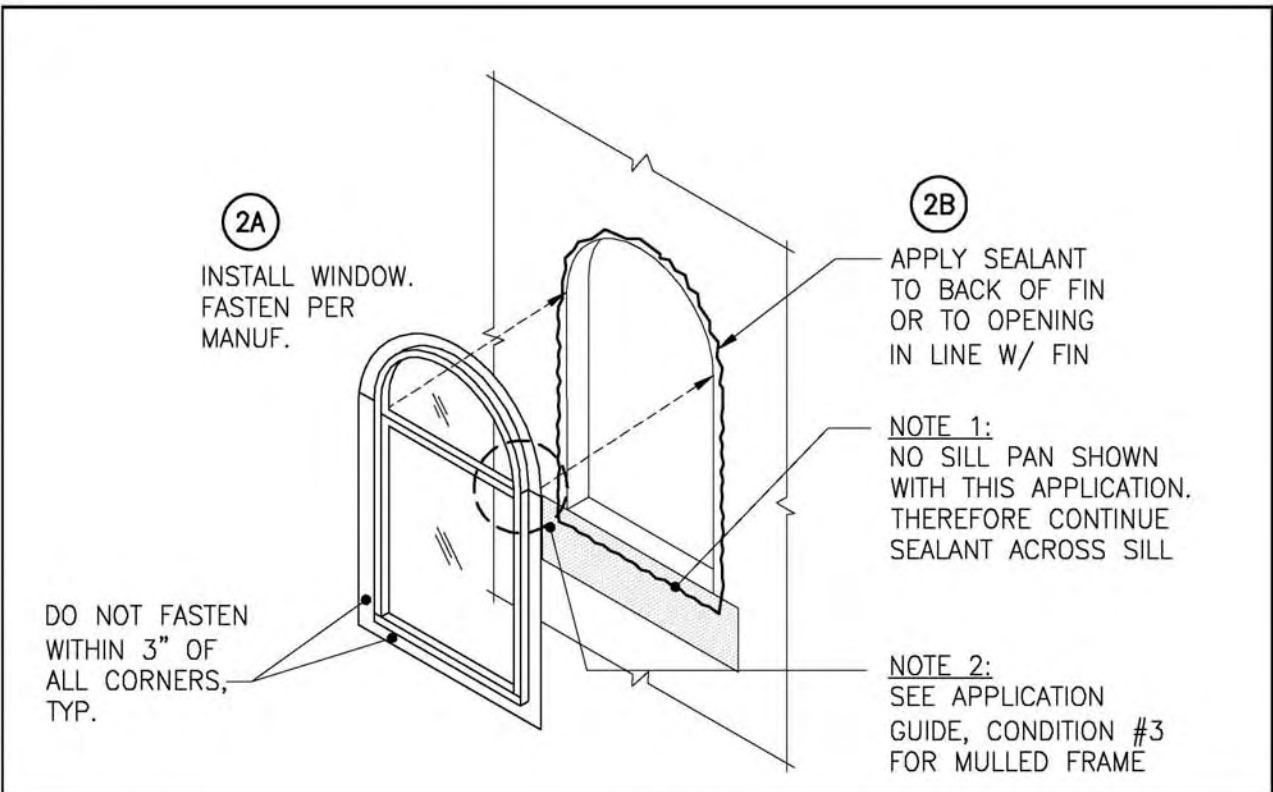

Project:
FLUSH OPENING, BUILDING PAPER
NAIL-FIN, ARCHED HEAD

Title:
CONTOUR: WINDOW FLASHING, METHOD A

Drawing No.:
FAB.2

:\Projects\2006\067220-POLY\Drafting\Working_Set\Details\7.0_Contour Flashing Sequence Diagrams\POLY_Fig-7.6_CFAB_01.dwg, 10/15/2007 3:20:01 PM, mcpowers

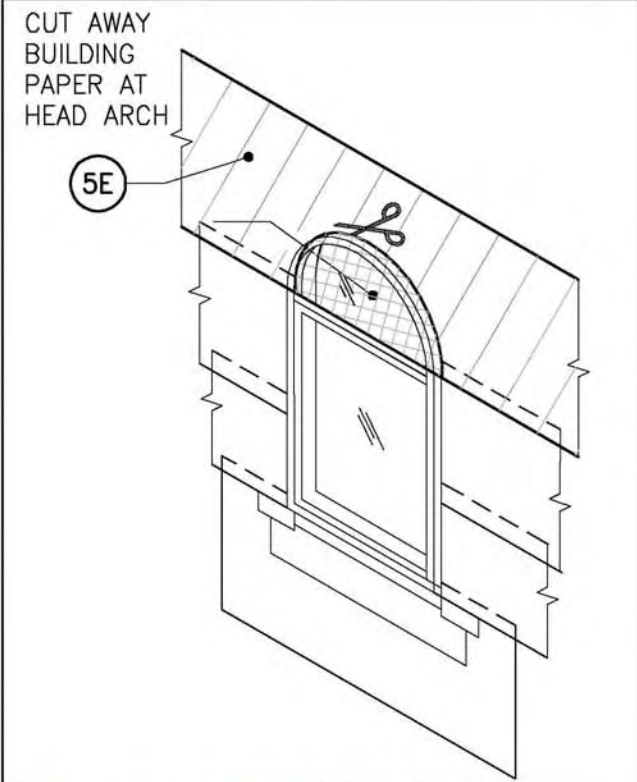
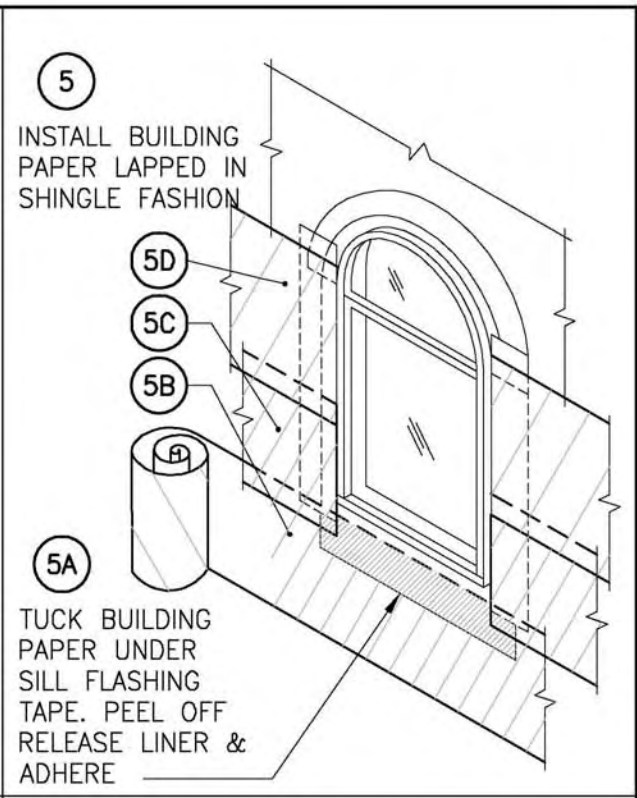
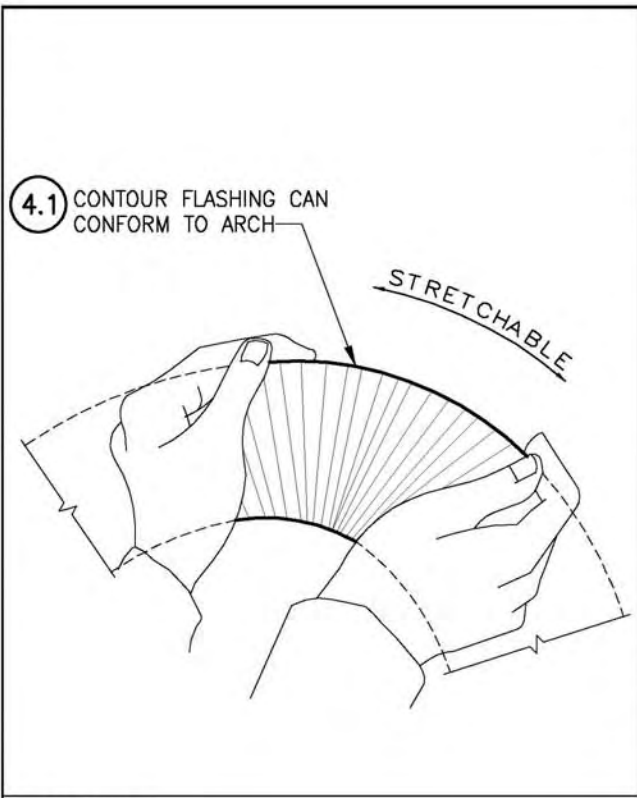

BERRYTM
PLASTICS CORPORATION
AND SUBSIDIARIES
TAPES AND COATINGS DIVISION

Project: FLUSH OPENING, BUILDING PAPER NAIL-FIN, ARCHED HEAD

Title: CONTOUR: WINDOW FLASHING, METHOD A

Drawing No: FAB.3

Polyken® and Nashua® Flashing Tapes

Self-adhering flashings are building industry products developed for windows, doors and skylights over the last 20 years. Their use started with membrane roofing underlayment protection and wrapping tapes for utility piping. They became recognized by builders as adaptable and versatile flashing materials for other building envelope locations.

Specification sections have recognized the traditional sheet metal flashing material in CSI* designated Section 07620 Sheet Metal Flashing & Trim. Contemporary flashing materials which include self-adhering flashing, as well as paper-based (asphalt-saturated kraft paper) and polymeric materials (housewrap), can be incorporated into Section 07650 Flexible Flashings.

Another specification option is to designate a unique self-adhering flashing section, e.g., 07660 Self Adhering Flashings. Section 07660 is not a specific section currently identified by CSI, but is consistent with the CSI organization system (1995 Master Format).

Specifications prepared with the 2004 CSI Master Format would be designated by 07-0650 for Flexible Flashings or 07-7660 for Self-Adhering Flashings.

Specification Title	CSI Section #	
	1995 Master Format	2004 Master Format
Flexible Flashings	07650	07-0650
Self-Adhering Flashing	07660	07-0660

There is also the specification option of placing flashing material specifications with their associated use for different building materials and separate construction sections. Therefore, specification sections for windows, doors, roof coverings and various wall claddings could have appropriate paragraphs included which outline the type and use of self-adhering flashing.

The following guide specification is based on the 1995 Master Format Section 07650 Flexible Flashings.

Specifier’s Note: This guide specification is not intended to be used word-for-word for any particular project. Specific installation procedures and instructions must be developed for each individual project. Berry Plastics does not warrant that this guide specification can be considered applicable under all conditions.

* Construction Specifications Institute, 1995 Master Format

Section 07650

Flexible Flashings

Specifier's Note: Edit guide specification content and format to suit the particular project. These specifications presume use with wood-frame construction and substrates.

PART 1 – GENERAL

1.01 SUMMARY

- A. Section includes: Installation of flexible, self-adhering flashing membrane consisting of, but not limited to, the sealing and flashing of above-grade building areas needing protection against water intrusion.
- B. Related Work
 - 1. Section 06100 — Rough Carpentry
 - 2. Section 07260 — Vapor Retarders (Weather-Resistant Barriers)
 - 3. Section 07270 — Air Barriers
 - 4. Section 07620 — Sheet Metal Flashing and Trim
 - 5. Section 07900 — Joint Sealers
 - 6. Section 08050 — Basic Door and Window Materials and Methods
 - 7. Section 08500 — Windows
 - 8. Section 08600 — Skylights

Specifier's Note: Edit the above sections as required to conform to specific project.

1.02 REFERENCES

- A. ASTM — American Society for Testing and Materials
 - 1. D 142-97 Test Methods for Sampling and Testing Bitumen – Saturated Felts and Woven Fabrics for Roofing and Waterproofing
 - 2. D 412-97 Test Methods for Rubber Properties in Tension
 - 3. D 903-93 Test Methods for Peel or Stripping Strength of Adhesive Bonds
 - 4. D 3767-96 Practice for rubber – Measurement of Dimensions

5. E 96-94 Test Methods for Water Vapor Transmission of Materials
 6. E-2112-07 Standard Practice for Installation of Exterior Windows, Doors, and Skylights
- B. AAMA – American Architectural Manufacturers Association
1. IM-TM – Installation Masters Training Manual, June 2000
 2. 711-05 Voluntary Specification for Self Adhering Flashing Used for Installation of Exterior Wall Penetration Products
 3. AAMA/WDMA 1600/I.S.7 – Voluntary Specifications for Skylights, 2000
- C. Berry Plastics, Flashing Tapes Manual, September 2007
1. Application Guide – General
 2. Application Guide – Windows/Doors/Skylights
- 1.03 SUBMITTALS
- A. Two copies of manufacturer's literature for all products furnished.
 - B. Two copies of Material Safety Data Sheets (MSDS).
 - C. Product sample(s). One sample of each of the sizes and types of product used on project.
- 1.04 QUALITY ASSURANCE
- A. Applicator shall be familiar with flexible, self-adhering flashing products and shall have experience in flexible, self-adhering flashing installation. Flashing shall be installed by skilled workers trained for this type of work with 3 years minimum experience.
- 1.05 PRODUCT DELIVERY, STORAGE AND HANDLING
- A. Deliver materials to job site in sealed, unopened cartons and containers.
 - B. Store products with protection from direct weather exposure. Store in original sealed packaging at temperatures between 5°-32°C (40°-90°F), and under moisture-free conditions.
 - C. Stack preformed material to prevent twisting, bending, or abrasion, and to provide ventilation.
 - D. Prevent contact with materials during storage which may cause discoloration, staining, or damage.

- E. Read and follow instructions from MSDS for proper handling and disposal of materials.

PART 2 – PRODUCTS

2.01 MATERIALS

- A. General: Polyken® and Nashua® Flashing Tapes as manufactured by:

Berry Plastics
25 Forge Parkway
Franklin, MA 02038
Website: www.berryplastics.com and www.covcorp.com
Telephone: (800) 248-7659

Polyken® and Nashua® Flashing Tapes consist of a butyl rubber adhesive with an outer facing and LDPE (low density polyethylene) release liner. The Polyken® and Nashua® Flashing Tapes provide a flexible and self-adhering strip of flashing membrane.

- B. Specific Products

1. Polyken® 626-35 Foilastic: 2 mil aluminum foil facing, butyl rubber adhesive membrane, LDPE release liner.
2. Polyken® 627-35 Shadowlastic: 6.5 mil LDPE black facing, butyl rubber adhesive membrane, LDPE release liner.
3. Nashua® 626-20 Optiflash: 2 mil aluminum, butyl rubber adhesive
4. Nashua® 627-20 Optiflash: 6 mil LDPE black facing, butyl rubber adhesive
5. Nashua® 697-40 Contour: creped, polyolefin facing, butyl rubber adhesive, coated paper release liner

2.02 ACCESSORIES

- A. Primer: Polyken #1027 Primer for use with porous substrates. Concrete, masonry, OSB and gypsum-core sheathings should be primed for better flashing adhesion.
- B. Sealant: As specified in Section 07900.
 1. Chemical Compatibility: Generally, sealants made with polyurethane, butyl, and silicone elastomers will have chemical compatibility to the facing and adhesive sides of Polyken® and Nashua® flashing tapes.
 2. Manufacturer: Check and confirm with specific sealant manufacturers regarding adhesion of specific sealants and application to Polyken® and Nashua® flashing tapes and the particular materials selected for fenestration product and the weather-resistant barrier.

3. Adhesion: Absent specific product selection for sealants, use the following general guide for adhesion to Polyken® and Nashua® facings. Check with sealant manufacturer for specific product information.

General Sealant Adhesion Characteristics to Flashing Tape			
Type of Sealant	Polyken® and Nashua® Flashing Tape		
	626 Foil Facing	627 Polyethylene Facing	697 Polymeric Facing
Butyl	Excellent	Excellent	Excellent
Polyurethane	Excellent	(May lack adhesion. Check with sealant manufacturer.)	(May lack adhesion. Check with sealant manufacturer.)
Silicone	Excellent	(May lack adhesion. Check with sealant manufacturer.)	(May lack adhesion. Check with sealant manufacturer.)

PART 3 – EXECUTION

3.01 PREPARATION

- A. Inspect and field measure site conditions and substrates prior to field fabricating work.
- B. Substrates shall be clean, dry, uniform, and smooth prior to flashing application. Remove protrusions and fill voids at substrates as necessary. Ensure fasteners are flush with surface of sheathing substrates.
- C. Allow wet substrates to dry thoroughly. Clean dust and debris from all substrates and surfaces receiving the flashing.
- D. Prime porous substrates with Polyken® #1027 primer according to manufacturer's recommendations. Prime concrete, masonry, oriented strand based (OSB) and gypsum core sheathing products. Polyken® #1027 is V.O.C. compliant.
- E. Provide solid continuous backing or substrate filler to support all portions of flexible flashing. Fill joints or gaps in substrate 1/8" or wider.

3.02 INSTALLATION

- A. General
 1. Manufactured products: Comply with manufacturer's written instructions.

2. Proceed with installation in conjunction with related weather-resistive barrier and flashing in each area of building envelope construction.
 3. Do not dilute primers or sealants
 4. Keep containers closed except when removing materials from them.
- B. Except as otherwise specifically indicated or shown on reviewed shop drawings, conform to drawing details included in manufacturer's recommendations.
 - C. Form sections true to shape, accurate in size, square, and free from distortion or defects.
 - D. Cut flashing strip to length. Form pieces in longest practical lengths. Peel back release liner and discard with small pieces of flashing. Align the flashing strip and press by hand into place. With larger flashing pieces, remove a small part of the release liner at the end of a flashing strip (4 to 6 inches). Then set the exposed flashing against the substrate and press into place. Afterwards, the remaining release liner still attached to the flashing is pulled back between the flashing and substrate. The release liner is peeled away, exposing additional adhesive in 12 to 24 inch long sections working away from the starting point.
 - E. Fit flashings tight in place. Make corners uniform, surfaces flat and straight in planes, and lines accurate to profiles.
 - F. Fabricate corners, transitions and terminations with a minimum number of pieces.
 - G. Lap joints for continuous contact. All seams and splices shall be overlapped 3 inches minimum. Lap joints in direction of moisture drainage, in shingle fashion, unless specifically designated otherwise.
 - H. Roll all flashings with a hand roller, taking special care at laps, seams, splice areas, and T joints to remove any voids and trapped air according to manufacturer's recommendations.
 - I. Do not apply flexible flashings to bridge or cover unsupported voids, gaps, or offset materials.

3.03 POST-INSTALLATION PROTECTION

- A. Protect exposed flashings after installation from mechanical damage, falling debris and prolonged direct weather exposure. Generally, Polyken® and Nashua® flashings will meet the following direct sun exposure limits for ultraviolet light:

Polyken® Flashing Tape – Direct UV Exposure Limits to Facing		
Polyken® and Nashua® Flashing Tape		
626 Foil Facing	627 Polyethylene Facing	697 Polymeric Facing
Indefinite	1 Year	1 Year

- B. Inspect for tears, rips, punctures, and other damage. Repair damage to flashings prior to covering flashings. Repair damage according to manufacturer’s recommendations.
- C. Apply exterior finish coverings over flashings in the proper construction sequence as soon as practical.

END OF SECTION

Specifier’s Note: This guide specification is not intended to be used word-for-word for any particular project. Specific installation procedures and instructions must be developed for each individual project. Berry Plastics does not warrant that this guide specification can be considered applicable under all conditions.

Covalence Adhesives
April 15, 2007

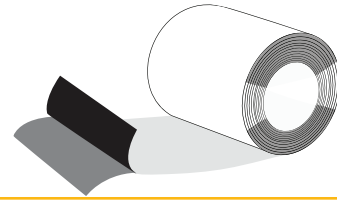

There have been numerous inquiries regarding caulking and sealant compatibility with flashing tapes used in building fenestrations. The Covalence Research and Development team conducted testing in October 2005 to determine how various caulking chemistries interact with the butyl rubber and rubberized asphalt adhesive compounds that are commonly used in self adhering flashing products. The tests showed dramatically different results between the two adhesive types. While the rubberized asphalt deteriorated quickly, the butyl rubber adhesive remained unaffected by the sealant chemistry.

The Research and Development team tested six sealant formulations composed of polyurethane, rubber, silicone and various solvents. The sealants were applied to both the film facer and the adhesive side of the flashing tapes. The butyl rubber flashing tape tested was made with a 6 mil polyethylene film backed with a butyl rubber adhesive formulation that is coated at 14 and 29 mils respectively onto Nashua Optiflash B20 and Polyken Shadowlastic. The SBS asphalt tape was comprised of a 2 mil polypropylene film backed with 25 mils of SBS asphalt similar to many types that are on the market.

The samples were put into an accelerated aging chamber at 150°F for 31 days. This method of accelerated aging can be the equivalent of 400 days of full exposure (depending on the region, elevation and season). Observations were taken each day for the duration of the test. The rubberized asphalt adhesive reacted with the sealants as indicated by the adhesive flow, within 2 to 6 days of exposure. The butyl rubber adhesive systems remained in tact exhibiting no adhesive breakdown or flow throughout the duration of the test. The caulking systems coated onto the butyl rubber adhesive remained inert. Specific information regarding the results is available upon request.

Proper selection of flashing materials is crucial to the permanence of the seal that protects the building structure from penetration of moisture, water vapor and air. Adverse reactions between flashing tape adhesives and sealants can compromise the integrity of the weatherproof seal. At a minimum, this can cause staining of building materials and air leakage. All too often, the degradation of the seal allows moisture penetration and retention that can contribute to mold and mildew development which will require corrective action.

Flashing Tape Adhesive Compatibility

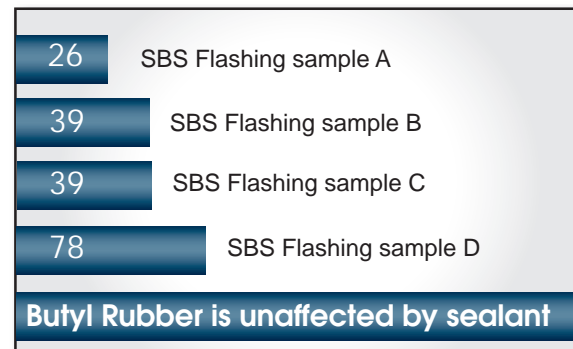

Number of days before breakdown of adhesives occurs when paired with various sealant types.*

*Each day of accelerated aging can be the equivalent of 13 days of full exposure (depending on the region, elevation and season) in the real world. Number of days shown in graph are shown from the real world perspective.

Material Safety Data Sheets

Material safety data sheets to be provided by client.

Distributed by: BEST MATERIALS LLC
Ph: 800-474-7570, 602-272-8128 Fax: 602-272-8014
www.BestMaterials.com Email: Sales@BestMaterials.com