

Dedendum

Dedendum is the length of the portion of the tooth from the pitch circle to the base of the tooth.

Addendum Circle (AC)

The AC is an imaginary circle over the tops of the gear teeth.

Outside Diameter (OD)

The OD is the diameter of the AC that contains the tops of the teeth.

Circular Pitch (CP)

The distance between the centers of two adjacent teeth, measured along the pitch circle.

Chordal Pitch

The distance from center to center of teeth measured along a straight line or chord of the pitch circle.

Root Diameter

The diameter of the circle measured at the root of the teeth.

Clearance

Clearance is the margin of space between the top of the tooth on one gear and the bottom of the tooth of the mating gear.

Whole Depth

The whole depth is the total distance from the top of the tooth to the bottom including the clearance.

Working Depth

The working depth is the greatest depth to which a tooth of one gear extends into the tooth space of another gear.

Face

The face of the tooth is the working surface of the tooth above the pitch line.

Thickness

The thickness of the tooth is the width of the tooth, taken as a chord of the pitch circle.

Rack Teeth

The toothed cuts made in a linear or rack gear, which, when meshed with a circular gear or pinion, change circular motion into linear motion. The linear pitch of the rack teeth must equal the circular pitch of the mating gear.

HELICAL SPRINGS

There are three classifications of helical springs: compression, extension, and torsion. Drawings seldom show a true representation of the helical shape; instead, they usually show springs with straight lines. Several methods of spring representation including both helical and straight-line drawings are illustrated in *Figure 4-15*. Also, springs are sometimes shown as single-line drawings, as in *Figure 4-16*.

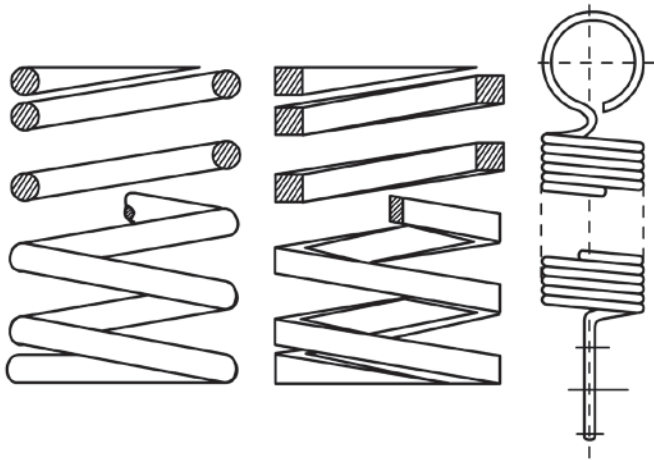

Figure 4-15 — Representation of common types of helical springs.



Figure 4-16 — Single line representation of

FINISH MARKS

The military standards for finish marks are set forth in American Society of Mechanical Engineers (ASME) B46.1-2009, Surface Texture (Surface Roughness, Waviness, and Lay). Many metal surfaces must be finished with machine tools for various reasons. The acceptable roughness of a surface depends upon how the part will be used. Sometimes only certain surfaces of a part need to be finished while others are not. A modified symbol (check mark) with a number or numbers above it is used to show these surfaces and to specify the degree of finish. The proportions of the surface roughness symbol are shown in Figure 4-17. On small drawings the symbol is proportionately smaller.

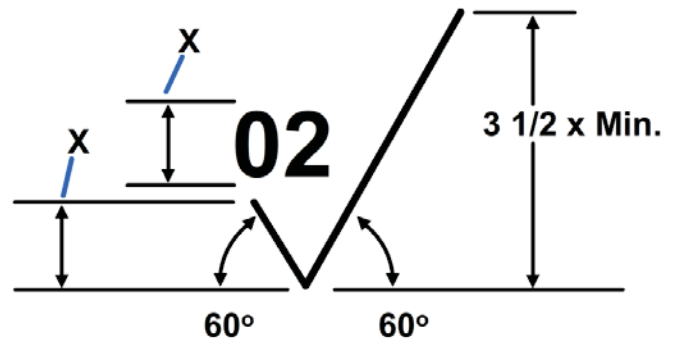

Figure 4-17 — Proportions for a basic finish symbol.

The number in the angle of the check mark, in this case 02, tells the machinist what degree of finish the surface should have. This number is the root-mean-square value of the surface roughness height in millionths of an inch. In other words, it is a measurement of the depth of the scratches made by the machining or abrading process.

Whenever possible, the surface roughness symbol is drawn touching the line representing the surface to which it refers. If space is limited, the symbol may be placed on an extension line on that surface or on the tail of a leader with an arrow touching that surface, as shown in Figure 4-18.

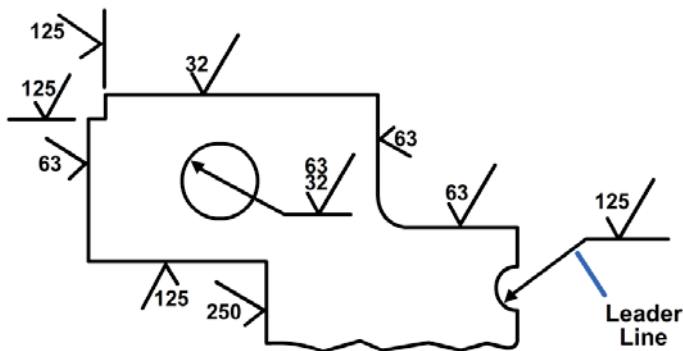

Figure 4-18 — Methods of placing surface roughness symbols.

When a part is to be finished to the same roughness all over, a note on the drawing will include the direction “finish all over” along the finish mark and the proper number. An example is FINISH ALL OVER³². When a part is to be finished all over but a few surfaces vary in roughness, the surface roughness symbol number or numbers are applied to the lines representing these surfaces and a note on the drawing will include the surface roughness symbol for the rest of the surfaces. For example, ALL OVER EXCEPT AS NOTED (*Figure 4-19*).

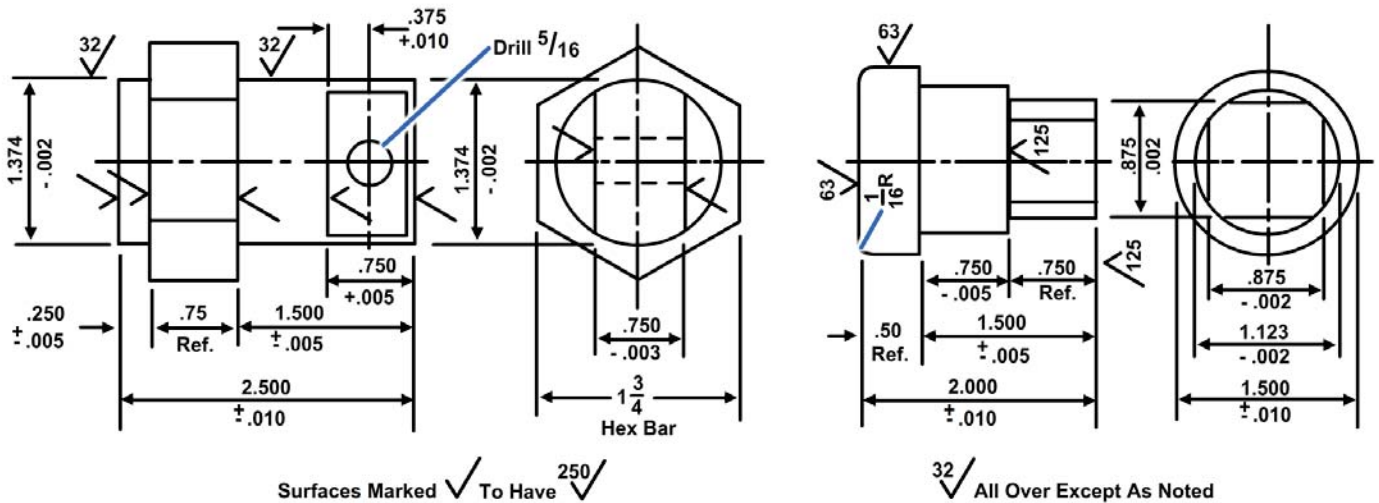

Figure 4-19 — Typical examples of the surface roughness symbol use.

STANDARDS

American industry has adopted the standard, American National Standards Institute (ANSI) Y14.5M-2009, Dimensioning and Tolerancing. This standard is used in all blueprint production, whether the print is drawn by a human hand or by computer-aided drawing (CAD) equipment. It standardizes the production of prints from the simplest hand-made job on site to single or multiple-run items produced in a machine shop with computer-aided manufacturing (CAM). For further information, refer to ANSI Y14.5M-2009 and to *Introduction to Geometrical Dimensioning and Tolerancing*, Lowell W. Foster, National Tooling and Machining Association, Fort Washington, MD, 1986.

The standards listed in *Table 4-1* contain most of the information on symbols, conventions, tolerances, and abbreviations used in shop or working drawings:

Table 4-1 — Common Standards

Number	Title
ANSI Y14.5M-2009	Dimensioning and Tolerancing
ANSI Y14.6-2001	Screw Thread Representation
ASME B46.1-2009	Surface Texture (Surface Roughness, Waviness, and Lay)
ASME Y14.38-2007	Abbreviations and Acronyms for Use on Drawings and Related Documents

End of Chapter 4

Machine Drawing

Review Questions

- 4-1. Which of the following terms describes a variation in a machine drawing?
- A. Fillet
 - B. Major diameter
 - C. Minor diameter
 - D. Tolerance
- 4-2. In what dimensioning method are the minimum and maximum measurements stated?
- A. Bilateral
 - B. Limit
 - C. Metric fillet
 - D. Unilateral
- 4-3. Which of the following terms describes a surface, line, or point from which a geometric position is to be determined?
- A. Datum
 - B. Slot
 - C. Switch
 - D. Tatum
- 4-4. In a cast, what feature increases the strength of a metal corner?
- A. Fillet
 - B. Keyseat
 - C. Slide
 - D. Slot
- 4-5. What feature describes a slot or groove on the outside of a part into which the key fits?
- A. Fillets
 - B. Slots and slides
 - C. Key
 - D. Keyseat
- 4-6. What part of a thread designator number identifies the nominal or outside diameter of a thread?
- A. The first
 - B. The second
 - C. The fourth
 - D. The letter designator

- 4-7. Which of the following screw-thread series are the most widely used?
- A. European Coarse and European Fine
 - B. European Coarse and National Standard
 - C. National Coarse and National Fine
 - D. National Metric and National Standard
- 4-8. Which of the following terms distinguishes threads from each other by the amount of tolerance and/or allowance specified?
- A. Class of pitch
 - B. Class of thread
 - C. National Standard
 - D. Thread pitch
- 4-9. Which of the following terms describes the surface of the thread that corresponds to the minor diameter of an external thread and the major diameter of an internal thread?
- A. External threads
 - B. Axis
 - C. Crest
 - D. Root
- 4-10. Which of the following terms describes the largest measurement of the external or internal thread?
- A. Crest
 - B. Major diameter
 - C. Minor diameter
 - D. Pitch
- 4-11. Which of the following definitions describes the term lead?
- A. The distance a screw thread advances on one turn, parallel to the axis
 - B. The distance the thread is cut from the crest to its root
 - C. The distance from the thread's pitch to its root dimension
 - D. The distance between external threads
- 4-12. Which of the following terms defines the distance from the root of the thread to the crest, when measured perpendicularly to the axis?
- A. Depth
 - B. Helix
 - C. Lead
 - D. Pitch

- 4-13. When sketching gears on a machine drawing, how many teeth are drawn?
- A. One quarter
 - B. One half
 - C. Enough to identify the necessary dimensions
 - D. All
- 4-14. Which of the following terms expresses the number of teeth on the gear divided by the diametral pitch?
- A. Pitch diameter
 - B. Outside diameter
 - C. Number of teeth
 - D. Addendum circle
- 4-15. Which of the following terms describes the imaginary circle that divided the teeth into top and bottom lands?
- A. Addendum circle
 - B. Chordal pitch
 - C. Circular pitch
 - D. Pitch circle
- 4-16. Which of the following terms describes the imaginary circle over the tops of the teeth?
- A. Addendum circle
 - B. Chordal pitch
 - C. Circular pitch
 - D. Pitch circle
- 4-17. Clearance is the marginal space between the top of one tooth and what other component?
- A. Adjacent tooth
 - B. Gear axle
 - C. Bottom of the tooth on the mating gear
 - D. Top of the tooth on the mating gear
- 4-18. What term identifies the working surface of the tooth above the pitch line?
- A. Addendum
 - B. Dedendum
 - C. Face
 - D. Thickness
- 4-19. What term describes the tooth cuts made in linear or rack gear?
- A. Pitch circle
 - B. Working depth
 - C. Rack face
 - D. Rack teeth

- 4-20. Which of the following are the three classifications of helical springs?
- A. Compression, extension, and double
 - B. Compression, extension, and torsion
 - C. Single, double, and triple
 - D. Single, extension, and torsion
- 4-21. What type of line is used to show springs on a drawing?
- A. Broken
 - B. Curved
 - C. Spiral
 - D. Straight
- 4-22. What standard is used for finish marks?
- A. ANSI 32.9-2006
 - B. ASME 14.3M
 - C. ASME B46.1-2009
 - D. IEEE 3009
- 4-23. Which of the following symbols is used to specify the degree of surface finish?
- A. Check mark
 - B. Parenthesis
 - C. Rectangle
 - D. Triangle
- 4-24. On a finish symbol, the number indicates the degree of finish to what surface height, in inches?
- A. Tenths
 - B. Hundredths
 - C. Thousandths
 - D. Millionths
- 4-25. What standard has the American industry adopted for blueprint production?
- A. IEEE 3009
 - B. ANSI 32.9-2006
 - C. ANSI Y14.5M-2009
 - D. ASME 14.3M

RATE TRAINING MANUAL – User Update

SWOS makes every effort to keep their manuals up-to-date and free of technical errors. We appreciate your help in this process. If you have an idea for improving this manual, or if you find an error, a typographical mistake, or an inaccuracy in SWOS manuals, please write or e-mail us, using this form or a photocopy. Be sure to include the exact chapter number, topic, detailed description, and correction, if applicable. Your input will be brought to the attention of the Technical Review Committee. Thank you for your assistance.

Write: SWOS Project Manager
1534 Piersey Street Suite 321
Norfolk, VA 23511-2613
COMM: (757) 444-5332
DSN: 564-5332

E-mail: Refer to the SWOS Norfolk page on the NKO Web page for current contact information.

Rate_____ Course Name_____
Revision Date_____ Chapter Number_____ Page Number(s)_____
Description _____ _____ _____
(Optional) Correction _____ _____ _____
(Optional) Your Name and Address _____ _____ _____

CHAPTER 5

PIPING SYSTEMS

Any drawing prepared by or for the Department of Defense must be prepared following the latest military standard, Department of Defense Standard, and applicable Naval Facilities Engineering Command design manuals. Many drawings continue in use for years; occasionally, you will have to work with drawings containing obsolete symbols. Look for a legend on the drawings; it should help you identify unfamiliar symbols. If there is no legend, studying the drawing carefully should enable you to interpret the meaning of unfamiliar symbols and abbreviations. This chapter discusses the symbols and markings used in the production of piping drawings and prints.

LEARNING OBJECTIVES

When you have completed this chapter, you will be able to do the following:

1. Recognize piping blueprints.
2. Identify shipboard piping blueprints.

PIPING DRAWINGS

Water was at one time the only important fluid that was moved from one point to another in pipes. Today almost every conceivable fluid is handled in pipes during its production, processing, transportation, and use. The age of atomic energy and rocket power has added fluids such as liquid metals, oxygen, and nitrogen to the list of more common fluids such as oil, water, gases, and acids that are being carried in piping systems today. Piping is also used as a structural element in columns and handrails. For these reasons contractors, manufacturers, and engineers should become familiar with pipe drawings. Piping drawings show the size and location of pipes, fittings, and valves. A set of symbols has been developed to identify these features on drawings.

Two methods of projection used in pipe drawings are orthographic and isometric (pictorial). Orthographic projection is used to show multiple views of an object in a single plane. Isometric projection is used to show a three-dimensional view of an object in single plane.

Orthographic Pipe Drawings

Single- and double-line orthographic pipe drawings (Figures 5-1 and 5-2) are recommended for showing single pipes either straight or bent in one plane only. This method also may be used for more complicated piping systems.

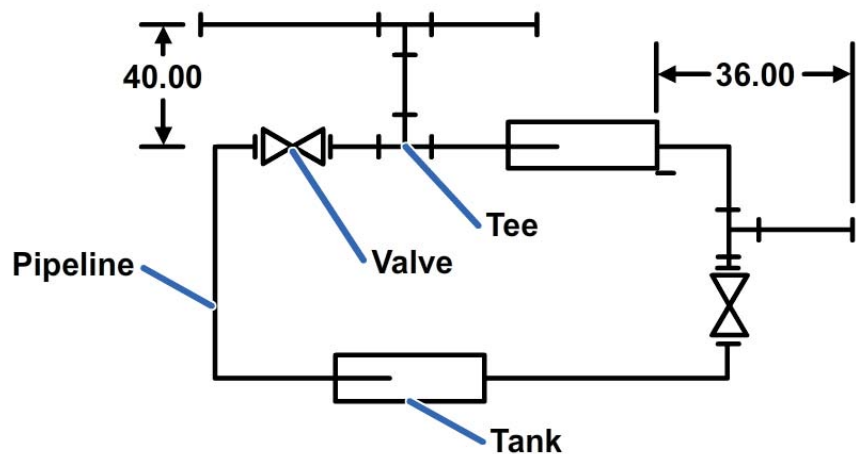

Figure 5-1 — Single-line orthographic pipe drawing.

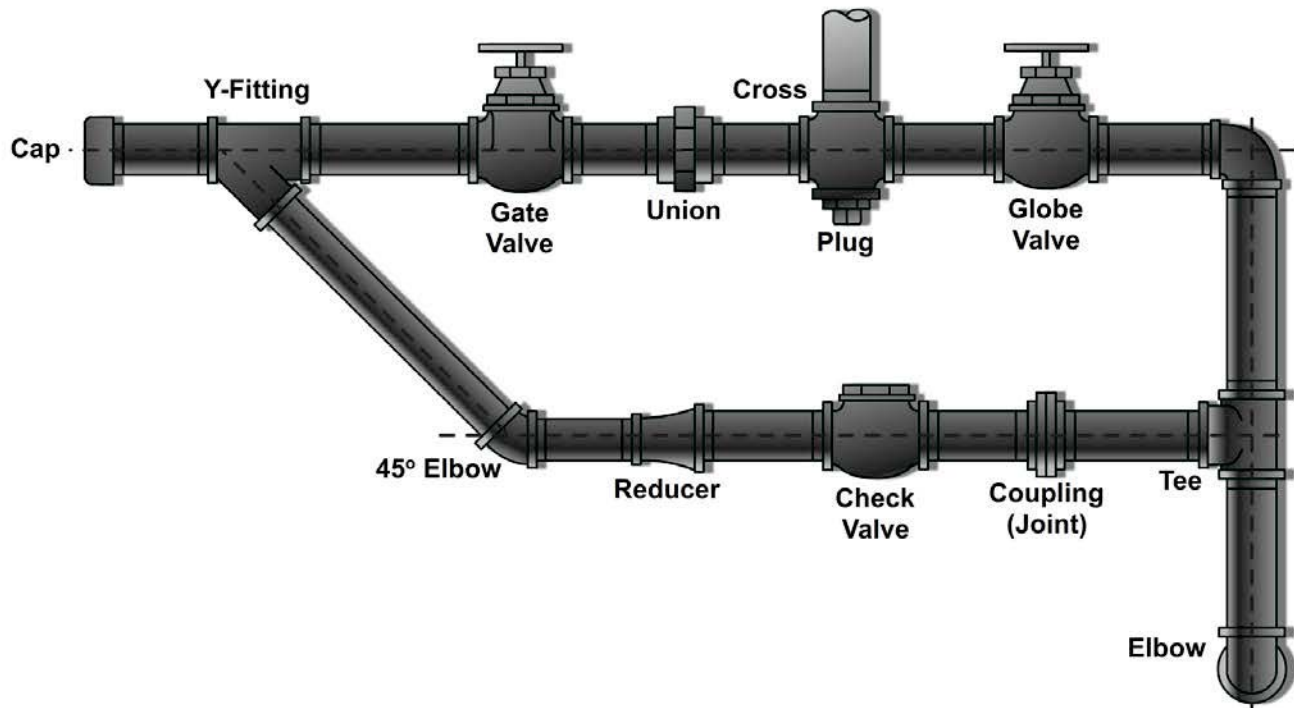

Figure 5-2 — Double-line orthographic pipe drawing.

Isometric (Pictorial) Pipe Drawings

Pictorial projection is used for all pipes bent in more than one plane, and for assembly and layout work. The finished drawing is easier to understand in the pictorial format.

Single-line drawings show the arrangement of pipes and fittings. A single-line isometric (pictorial) drawing of *Figure 5-1* is illustrated in *Figure 5-3*. The center line of the pipe is drawn as a thick line to which the valve symbols are added.

Single-line drawings take less time and show all information required to lay out and produce a piping system.

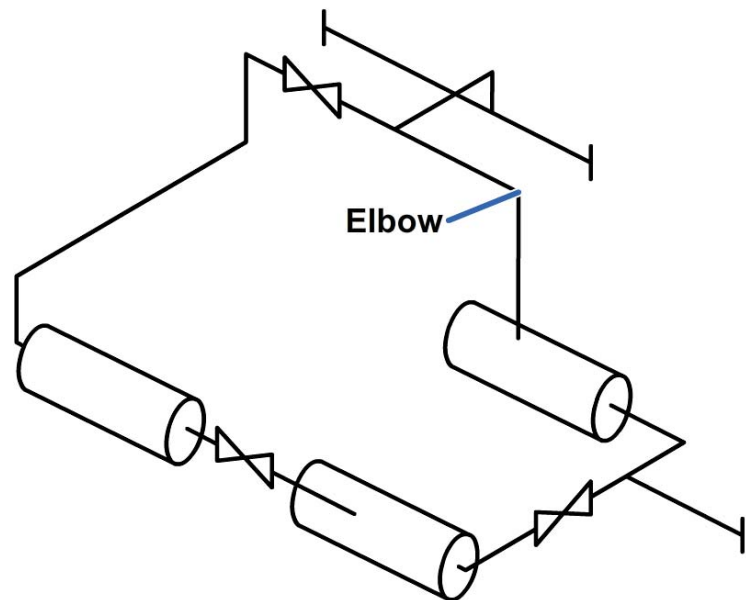

Figure 5-3 — Single-line isometric (pictorial) piping drawing.

Double-line pipe drawings require more time to draw and therefore are not recommended for production drawings. An example of a double-line pictorial pipe drawing is shown in *Figure 5-4*. They are generally used for catalogs and similar applications where visual appearance is more important than drawing time.

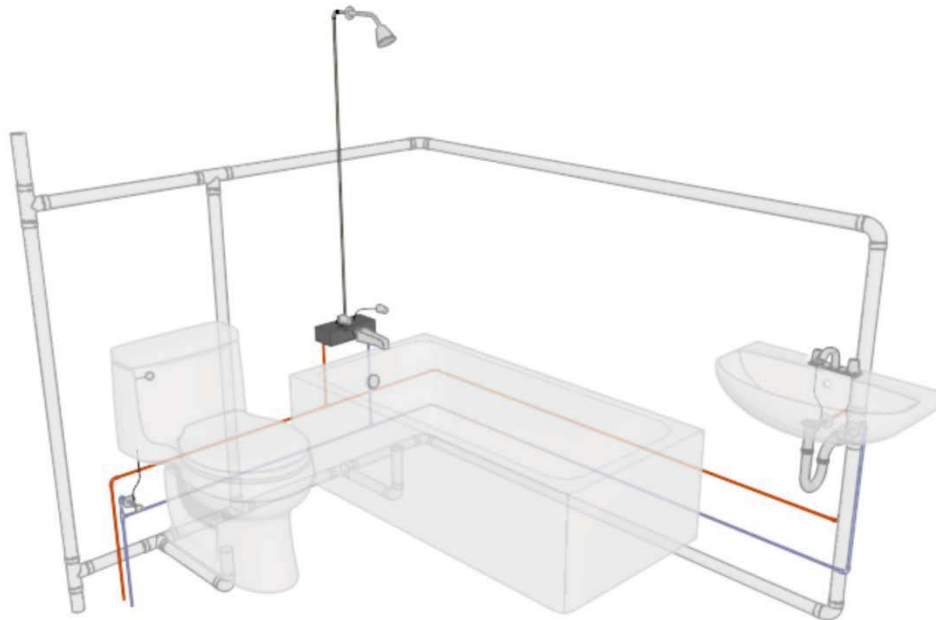

Figure 5-4 — Double-line pictorial piping drawing.

Crossings

The crossing of pipes without connections is normally shown without interrupting the line representing the hidden line (*Figure 5-5*). But when there is a need to show that one pipe must pass behind another, the line representing the pipe farthest from the viewer will be shown with a break, or interruption, where the other pipe passes in front of it, as shown in *Figure 5-5*.

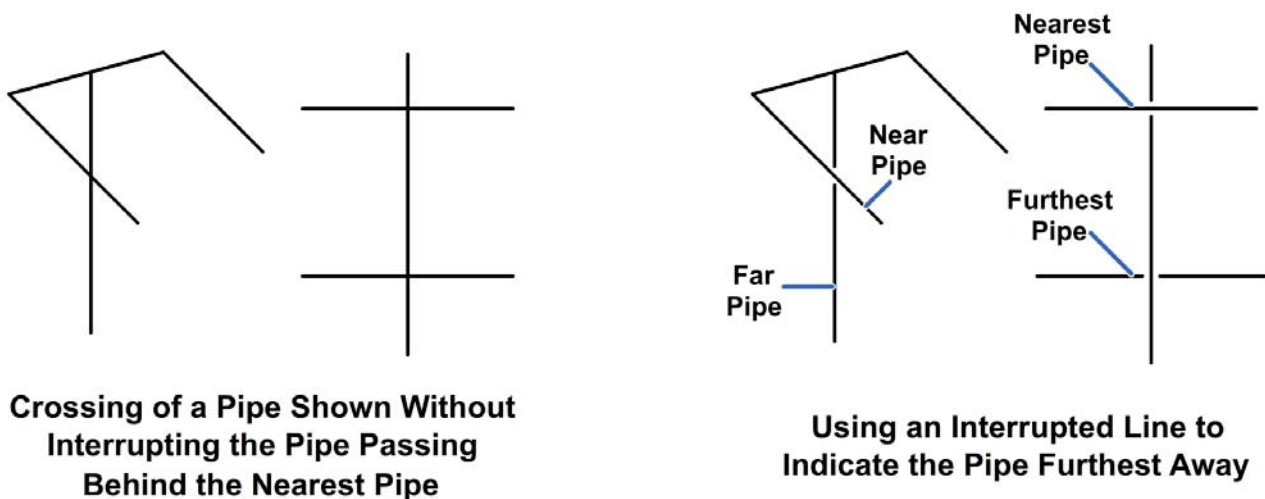

Figure 5-5 — Crossing of pipes.

Connections

Permanent connections, whether made by welding or other processes such as gluing or soldering, should be shown on the drawing by a heavy dot (Figure 5-6). A general note or specification is used to describe the type of connection.

Detachable connections are shown by a single thick line (Figures 5-6 and 5-7). The specification, a general note, or bill of material will list the types of connections such as flanges, unions, or couplings and whether the fittings are flanged or threaded.

Fittings

If standard symbols for fittings such as tees, elbows, and crossings are not shown on a drawing, they are represented by a continuous line. They define the size of the pipe, the method of branching and coupling, and the purpose of the pipe. This information is important because the purpose of the pipe determines what piping material to use. The inverse is also true; the piping material will determine how it can be used. A circular symbol for a tee or elbow may be used to indicate the piping coming toward or moving away from the viewer, as shown in Figure 5-8.

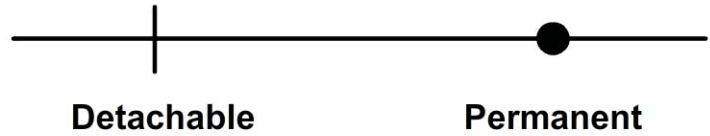

Figure 5-6 — Pipe connection.

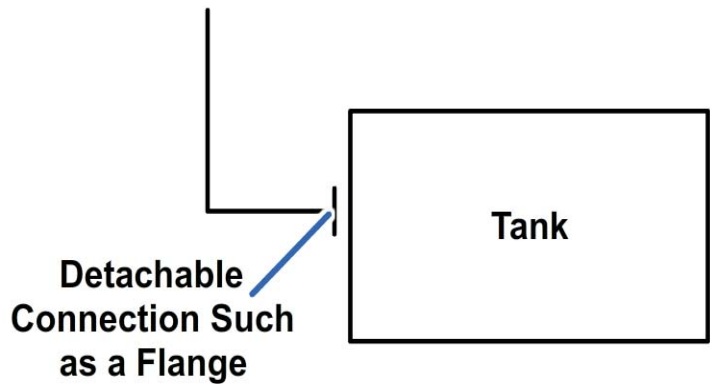

Figure 5-7 — Adjoining apparatus.

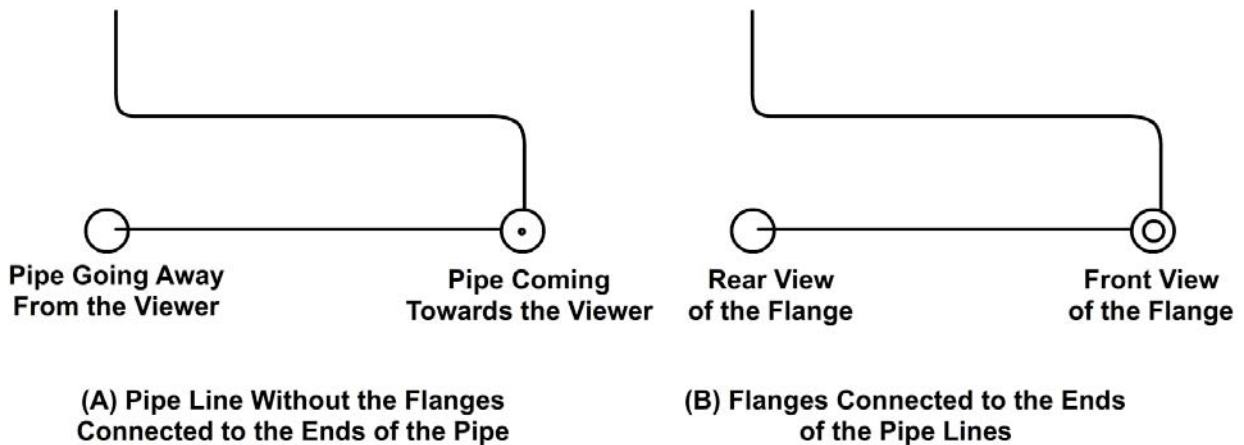

Figure 5-8 — Indicating ends of pipe and fittings.

Symbols and Markings

The American Society for Testing and Materials (ASTM) Standard F1000-13 lists mechanical symbols used on piping prints other than those for aeronautical craft, aerospacecraft, and spacecraft. Many of these symbols are listed in the Aviation Hydraulics Manual, Naval Air Systems Command (NAVAIR) 01-1A-17. Some of the common plumbing and piping symbols from the ASTM Standard F1000-13 and the Symbols, Piping Systems, Naval Sea Systems Command (NAVSEA) Standard Drawing 803-5001049 are illustrated in *Figure 5-9*.

Plumbing		Piping	
Corner Bath		Soil and Waste	
Recessed Bath		Soil and Waste, Underground	
Roll Rim Bath		Vent	
Sitz Bath		Cold Water	
Floor Bath		Hot Water	
Bidet		Hot Water Return	
Shower Stall		Fire Line	
Shower Head		Gas	
Overhead Gang Shower		Acid Waste	
Pedestal Lavatory		Drinking Water Supply	
Wall Lavatory		Drinking Water Return	
Corner/Manicure Lavatory		Vacuum Cleaning	
Medical Lavatory		Compressed Air	
Dental Lavatory		Pipe Fittings	
Plain Kitchen Sink		Joint	
Kitchen Sink, R & L Drain Board		Elbow - 90	
Combination Sink and Dishwasher		Elbow - 45	
Combination Sink & Laundry Tray		Elbow - Turned Up	
Service Sink		Elbow - Turned Down	
Wash Sink (Wall Type)		Elbow Long Radius	
Wash Sink		Side Outlet Elbow - Outlet Down	
Laundry Tray		Side outlet Elbow - Outlet Up	
Water Closet (Low Tank)		Base Elbow	
Water Closet (No Tank)		Double Branch Elbow	
Urinal (Pedestal Type)		Single Sweep Tee	
Urinal (Wall Type)		Reducing Elbow	
Urinal (Corner Type)		Tee	
Urinal (Stall Type)		Tee - Outlet UP	
Drinking Fountain (Pedestal Type)		Tee - Outlet Down	
Drinking Fountain (Wall Type)		Side Outlet Tee - Outlet Up	
Drinking Fountain (Trough Type)		Side Outlet Tee - Outlet Down	
Hot Water Tank		Cross	
Water Heater		Reducer	
Meter		Lateral	
Hose Bibb		Expansion Joint Flanged	
Gas Outlet		Valves	
Vacuum Outlet		Gate Valve	
Drain		Globe Valve	
Cleanout		Angle Glove Valve	
Garage Drain		Angle Gate Valve	
Floor Drain With Backwater Valve		Check Valve	
Roof Sump		Angle Check Valve	
		Safety Valve	
		Motor Operated Gate Valve	

Figure 5-9 — Common plumbing and piping symbols.

Notice that the symbols may show the type of connections (screwed, flanged, welded, and so forth) and fittings, valves, gauges, and items of the equipment. When an item is not covered in the standards, the responsible activity designs a suitable symbol and provides an explanation in a note.

When a print shows more than one piping system of the same kind, additional letters are added to the symbols to differentiate between the systems. Notice the letters on the drinking water supply and drinking water return lines in *Figure 5-9*.

The Military Standard 101 (MIL-STD-101) establishes the color code used to identify piping carrying hazardous fluids. It applies to all piping installations in naval industrial plants and shore stations where color coding is used. While all valve wheels on hazardous fluid piping must be color coded, color coding on the piping itself is optional. The warning colors painted on valve wheels and pipe lines carrying hazardous fluids is illustrated in *Table 5-1*.

Table 5-1 — Warning Colors

Class	Standard Color	Identification Marking	Class of Material
A	Yellow	FLAM	FLAMMABLE MATERIALS. All materials known ordinarily as flammables or combustibles. Of the chromatic colors, yellow has the highest coefficient of reflection under white light and can be recognized under the poorest conditions of illumination.
B	Brown	TOXIC	TOXIC AND POISONOUS MATERIALS. All materials extremely hazardous to life or health under normal conditions as toxics or poisons.
C	Blue	AAHM	ANESTHETICS AND HARMFUL MATERIALS. All materials productive of anesthetic vapors and all liquid chemicals and compounds hazardous to life and property but not normally productive of dangerous quantities of fumes or vapors.
D	Green	OXYM	OXIDIZING MATERIALS. All materials which readily furnish oxygen for combustion, and fire producers which react explosively or with the evolution of heat in contact with many other materials.
E	Gray	PHDAN	PHYSICALLY DANGEROUS MATERIALS. All materials not dangerous in themselves, but which are asphyxiating in confined areas or which are generally handled in a dangerous physical state of pressure or temperature.
F	Red	FPM	FIRE PROTECTION MATERIALS. Materials provided in piping systems or in compressed gas cylinders for use in fire protection.

Fluid lines in aircraft are marked according to Markings, Functions, and Hazardous Designations of Hose, Pipe, and Tube Lines for Aircraft Missile, and Space Systems, Military Standard (MIL-STD) 1247D. The types of aircraft fluid lines with the associated color code and symbol for each type is illustrated in *Figure 5-10*. Aircraft fluid lines are marked with an arrow to show direction of flow and hazard marking. The following paragraphs describe the markings for the four general classes of hazards, and *Table 5-2* shows examples of the hazards in each class.

FUNCTION	COLOR	SYMBOL
Fuel	Red	◆
Rocket Oxidizer	Green, Gray	☾
Rocket Fuel	Red, Gray	◆☾
Water Injection	Red, Gray, Red	∇
Lubrication	Yellow	⋮
Hydraulic	Blue, Yellow	●
Solvent	Blue, Brown	≡
Pneumatic	Orange, Blue	⊗
Instrument Air	Orange, Gray	∞
Coolant	Blue	~
Breathing Oxygen	Green	■
Air Conditioning	Brown, Gray	⋯
Monopropellant	Yellow, Orange	T
Fire Protection	Brown	◆
De-icing	Gray	▲
Rocket Catalyst	Yellow, Green	
Compressed Gas	Orange	/
Electrical Conduit	Brown, Orange	⚡
Inerting	Orange, Green	++

Figure 5-10 — Aircraft fluid line markings.

Table 5-2 — Hazards Associated with Various Fluids

CONTENTS	HAZARD
Air (under pressure)	PHDAN
Alcohol	FLAM
Carbon dioxide	PHDAN
Freon	PHDAN
Gaseous oxygen	PHDAN
Liquid nitrogen	PHDAN
Liquid oxygen	PHDAN
Liquid Petroleum Gas (LPG)	FLAM
Nitrogen gas	PHDAN
Oils and greases	FLAM
JP-4	FLAM
Trichloroethylene	AAHM

SHIPBOARD PIPING PRINTS

There are various types of shipboard piping systems. An example of a fuel oil service tank system is illustrated in *Figure 5-11*. Notice the drawing uses the standard symbols shown in *Figure 5-9*. Some small piping diagrams do not include a symbol list; therefore, you must be familiar with the standard symbols to interpret these diagrams.

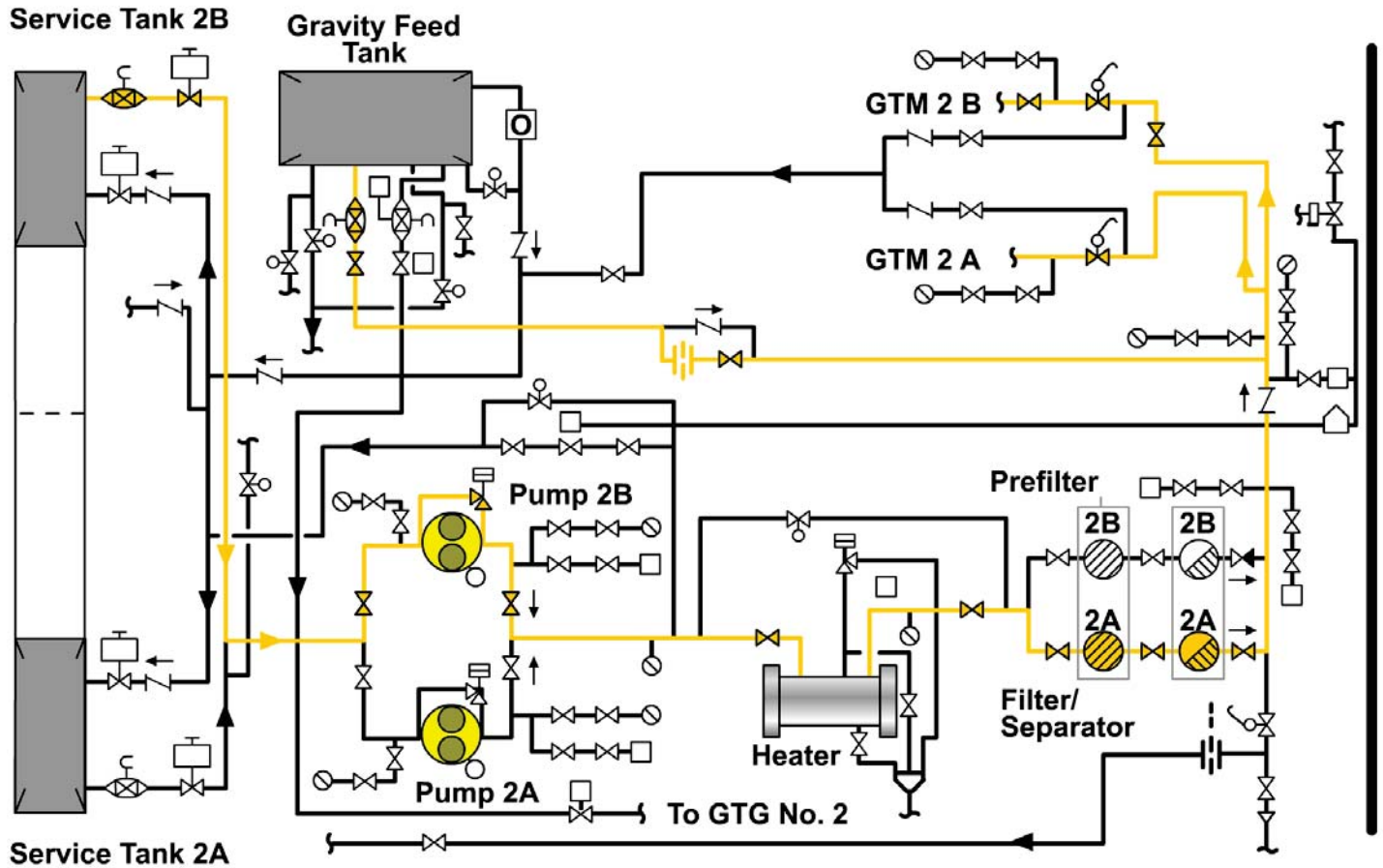

Figure 5-11 — Example of a fuel oil service tank.

Standard symbols are generally not used in drawings of shipboard piping systems found in operation and maintenance manuals. Each fitting in those systems may be drawn in detail (pictorially), as shown in *Figure 5-12*, or a block diagram arrangement (*Figure 5-13*) may be used.

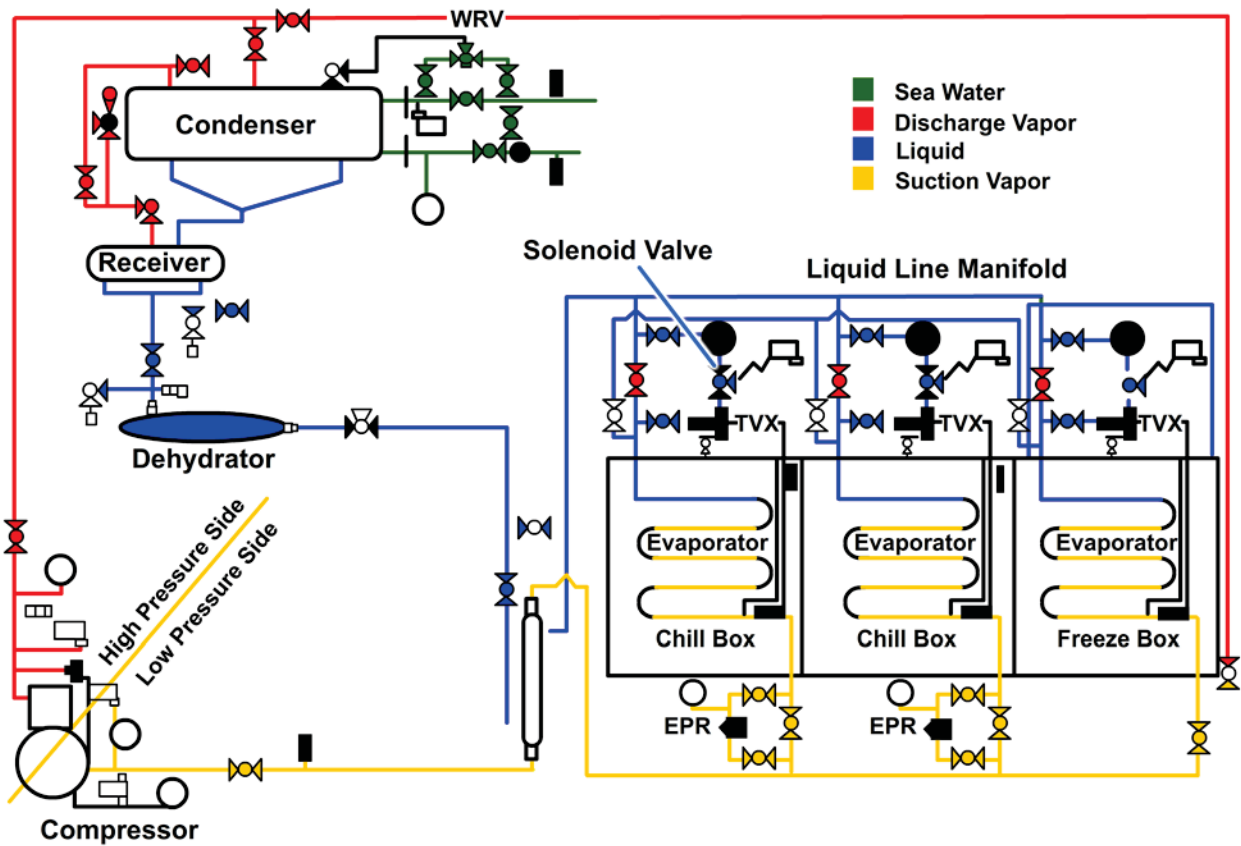

Figure 5-12 — Diagram of an R-134a refrigeration system.

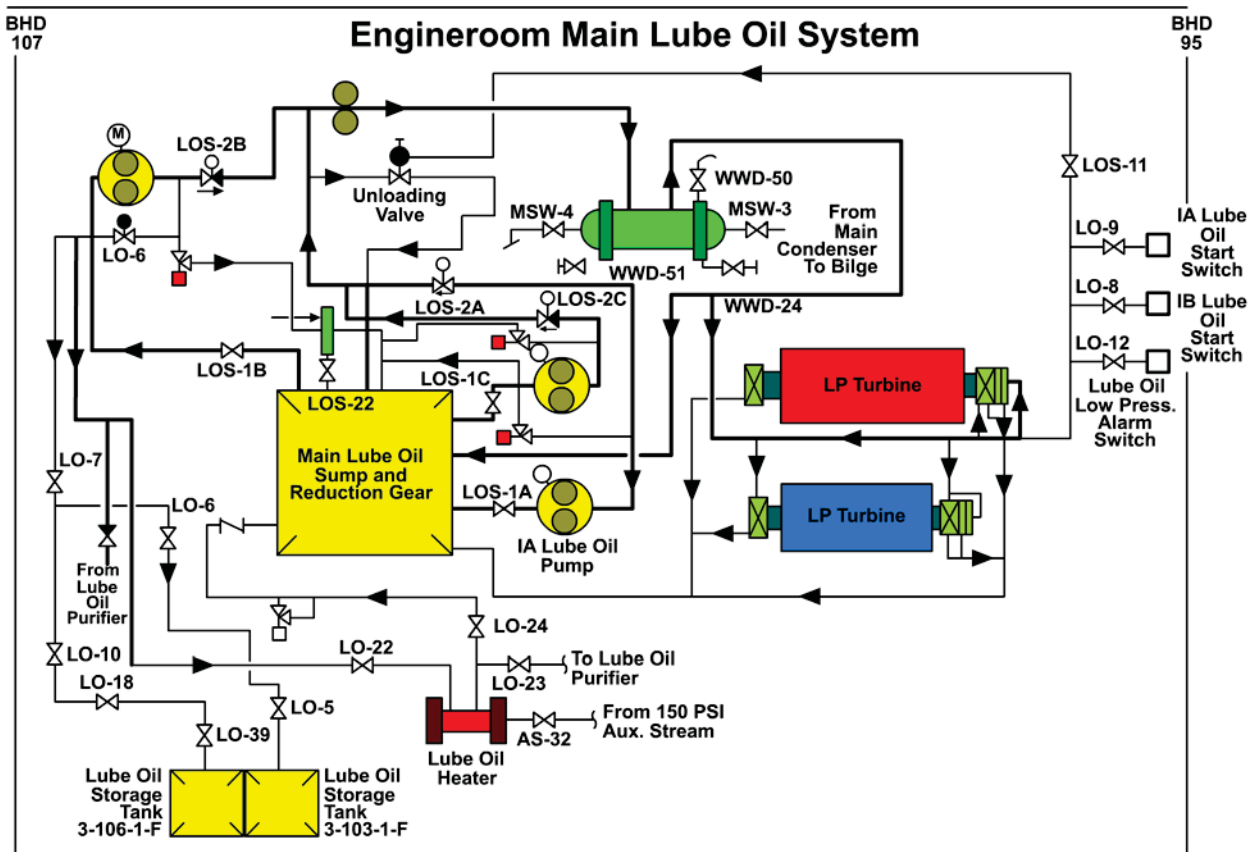

Figure 5-13 — Typical main lube oil system.

Hydraulic Prints

The Navy uses hydraulic systems, tools, and machines in various applications. Hydraulic systems are used on aircraft and aboard ship to activate weapons, navigational equipment, and remote controls of numerous mechanical devices. Shore stations use hydraulically operated shop equipment for maintenance and repair. Hydraulic systems are also used in construction, automotive, and weight-handling equipment. Basic hydraulic principles are discussed in the nonresident training course Fluid Power, Naval Education and Training (NAVEDTRA) 14105A.

To help you distinguish one hydraulic line from another, the lines are designated according to their function within the system. In general, hydraulic lines are designated as follows:

Supply Lines

Supply lines, also called suction lines, carry fluid from the reservoir to the pumps.

Pressure Lines

These lines carry only pressure. The pressure lines lead from the pumps to a pressure manifold and from the pressure manifold to the various selector valves, or they may lead directly from the pump to the selector valve.

Operating Lines

The operating lines, also called working lines, alternate carrying pressure to an actuating unit and returning fluid from the actuating unit. Each line is identified according to the specific function.

Return Lines

Return lines return fluid from any portion of the system to a reservoir.

Vent Lines

Vent lines carry excess fluid overboard or into another receptacle.

Hydraulic Symbols

The NAVAIR 01-1A-17, ASTM Standard F1000-13, and the NAVSEA Standard Drawing 803-5001049 list some of symbols that are used on hydraulic diagrams. *Figure 5-14* shows the outline of basic hydraulic symbols. In the actual hydraulic diagrams, the basic symbols are often improved, showing a cutaway section of the unit.

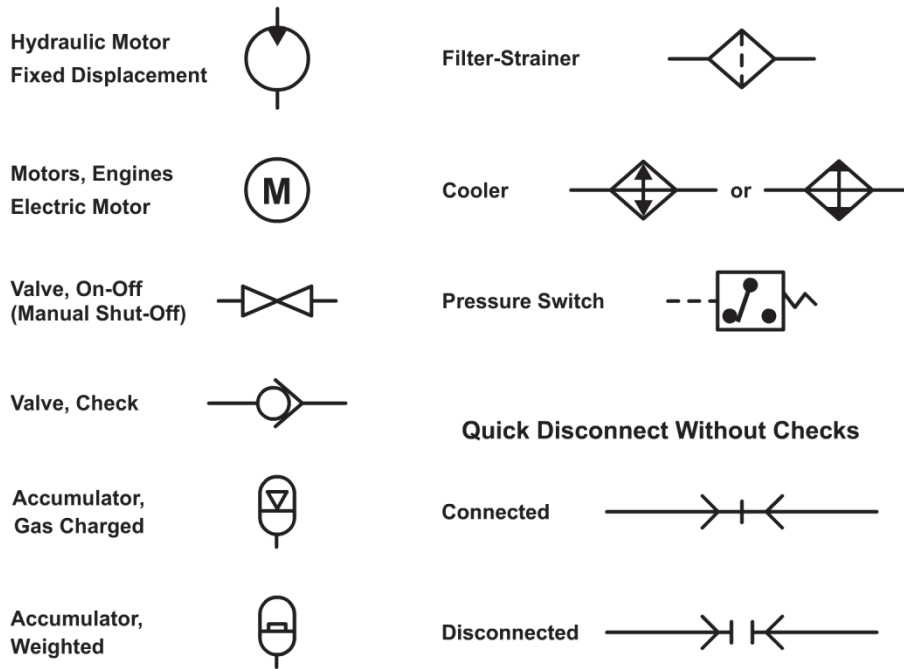

Figure 5-14 — Basic hydraulic symbols.

The lines on the hydraulic diagram shown in *Figure 5-15* are identified as to purpose, and the arrows point the direction of flow. Some additional symbols and conventions used on aircraft hydraulic and pneumatic systems and in fluid power diagrams are shown in *Figure 5-16*.

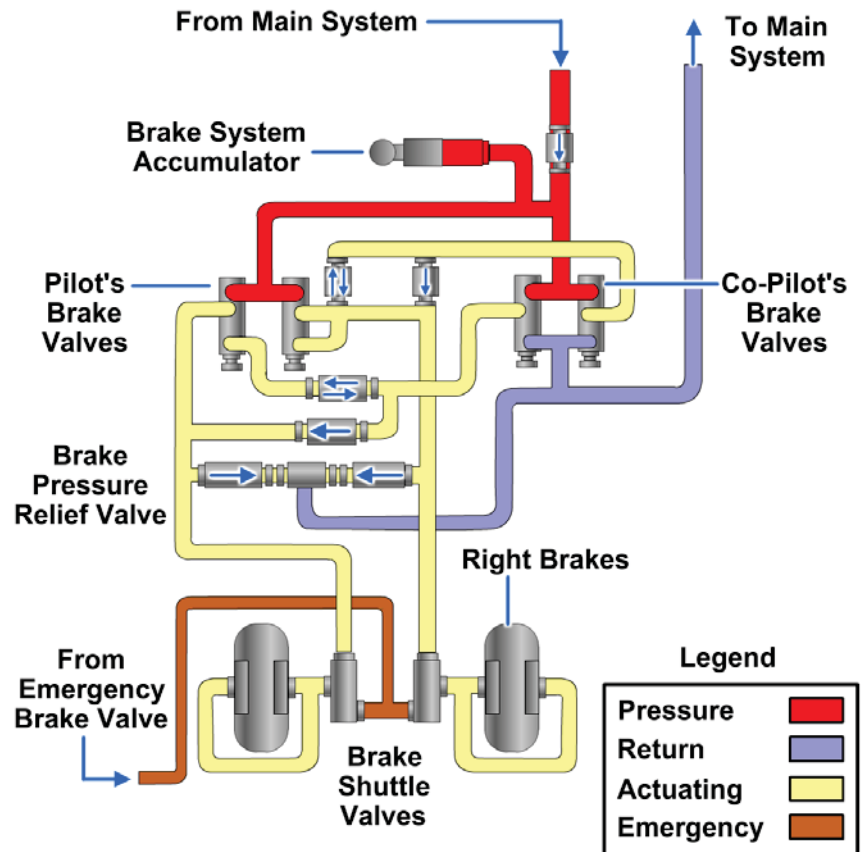

Figure 5-15 — Typical power brake control valve system.

Fluid Connectors

Line, Working (Main)



Line, Pilot (for Control)



Line, Exhaust and Liquid Drain



Flow, Direction of (Hydraulic)



Line, Flexible



Quick Disconnect Without Checks

Connected



Disconnected



Line, with Fixed Restriction

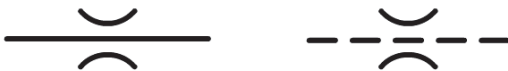

Lines, Crossing

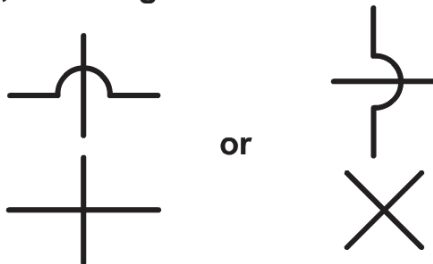

Lines, Joining



or



Energy Storage & Fluid Storage

Reservoir Vented



Pressurized



Above Fluid Level



Accumulator



Accumulator, Spring Loaded



Figure 5-16 — Fluid power symbols.

Plumbing Prints

Plumbing prints use many of the standard piping symbols shown in *Figure 5-9*. The ASTM Standard F1000-13 and the NAVSEA Standard Drawing 803-5001049 list other symbols that are used in plumbing prints.

A pictorial drawing of a bathroom is shown in *Figure 5-17*. In the drawing, all that is normally placed in or under the floor has been exposed to show a complete picture of the plumbing, connections, and fixtures.

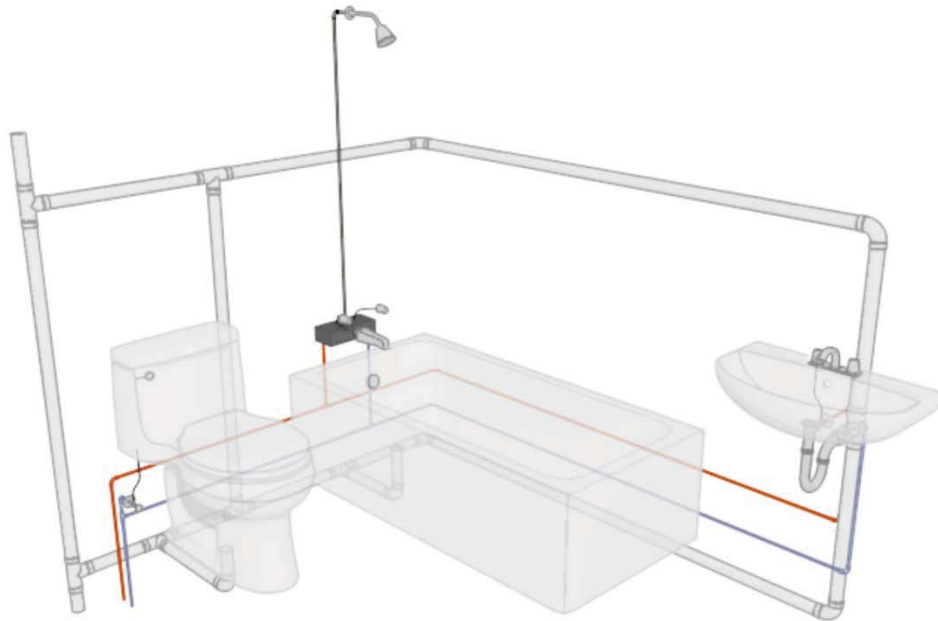

Figure 5-17 — Pictorial view of a typical bathroom.

Figure 5-18 is an isometric diagram of the piping in the bathroom shown in *Figure 5-17*. To interpret the isometric plumbing diagram shown in *Figure 5-18*, start at the lavatory (sink). You can see a symbol for a P-trap that leads to a tee connection. The portion of the tee leading upward leads to the vent and the portion leading downward leads to the drain. You can follow the drain pipe along the wall until it reaches the corner, where a 90-degree elbow is connected to bring the drain around the corner. Another section of piping is connected between the elbow and the next tee. One branch of the tee leads to the P-trap of the bathtub, and the other to the tee necessary for the vent (pipe leading upward between the tub and water closet). It then continues on to the Y-bend with a heel (a special fitting) that leads to a 4-inch main house drain. The vent pipe runs parallel to the floor drain, slightly above the lavatory.

Figure 5-18, is an isometric drawing of the water pipes, one for cold water and the other for hot water. These pipes are connected to service pipes in the wall near the soil stack, and they run parallel to the drain and vent pipes. Look back at *Figure 5-17* and you can see that the water service pipes are located above the drain pipe.

A floor plan of a small house showing the same bathroom, including the locations of fixtures and piping, is shown in *Figure 5-19*.

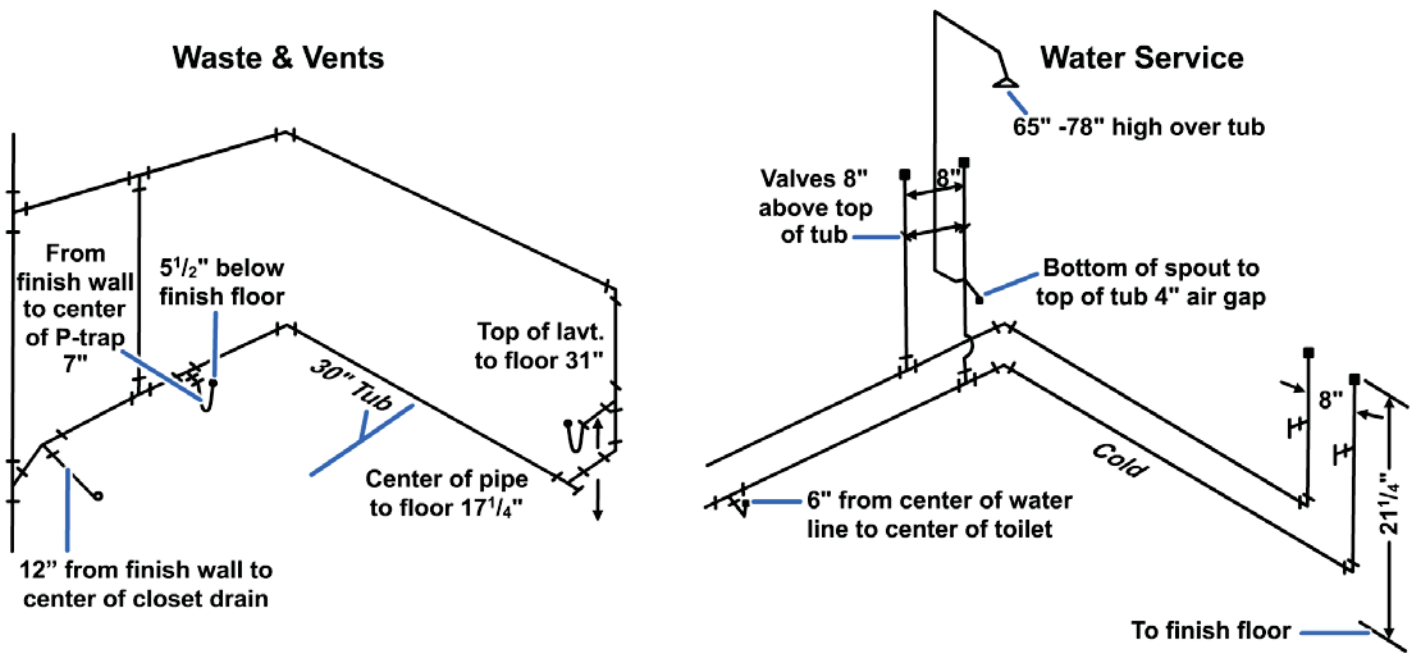

Figure 5-18 — Isometric diagram of a bathroom showing waste, vents, and water service.

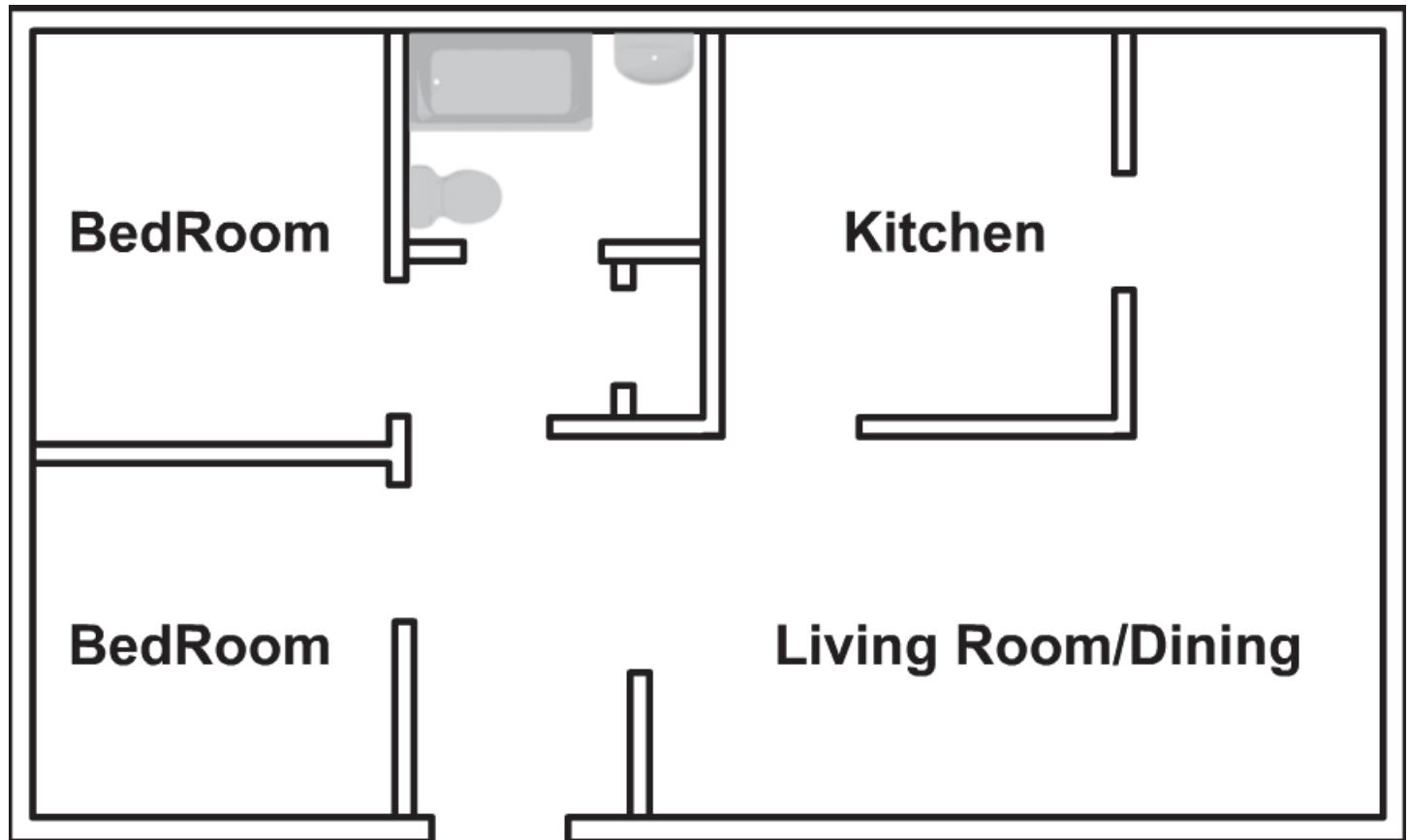

Figure 5-19 — Typical floor plan.

Reading Piping Designations

To learn how to interpret piping designations, refer to *Figure 5-20*. Each opening in a fitting is identified with a letter. For example, the fitting at the right end of the middle row shows a cross reduced on one end of the run and on one outlet. On crosses and elbows, always read the largest opening first and then follow the alphabetical order. So, if the fitting has openings sized 2½ by 1½ by 2½ by 1½ inches, you should read them in this order: A = 2½, B = 1½, C = 2½, and D = 1½ inches.

On tees, 45-degree Y-bends or laterals, and double-branch elbows, you always read the size of the largest opening of the run first, the opposite opening of the run second, and the outlet last. For example, look at the tee in the upper right corner of *Figure 5-20* and assume it is sized 3 by 2 by 2 inches. You would read the openings as A = 3, B = 2, and C = 2 inches.

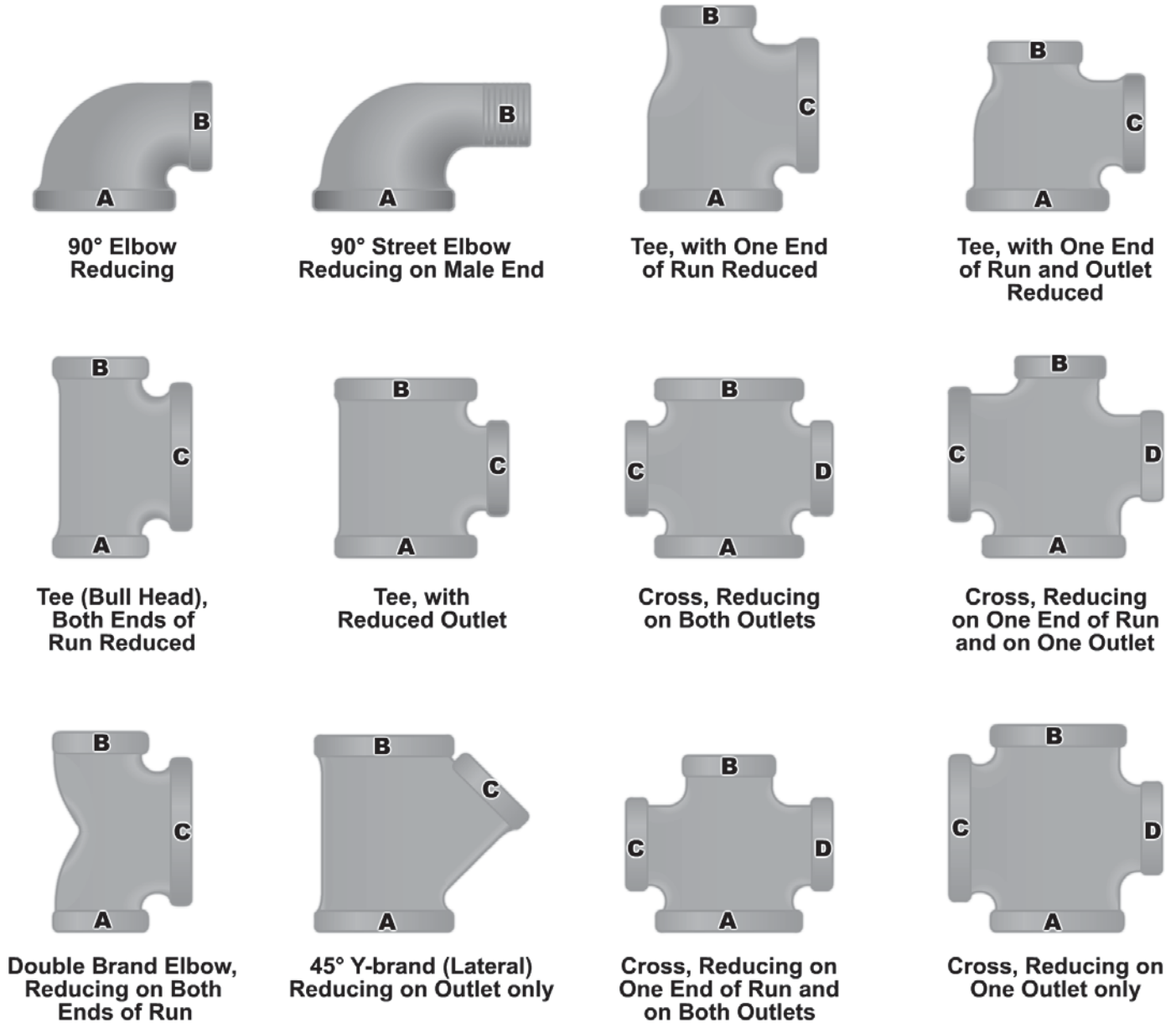

Figure 5-20 — How to read fittings.

End of Chapter 5

Piping Systems

Review Questions

- 5-1. Piping drawings show the size and location of pipes, fittings, and what other device?
- A. Plug
 - B. Pump
 - C. Strainer
 - D. Valve
- 5-2. Which of the following methods of projection are used in pipe drawings?
- A. Isometric and topographic
 - B. Orthographic and isometric
 - C. Orthographic and topographic
 - D. Topographic and view
- 5-3. What type of drawing is recommended for showing pipes either straight or bent in one plane?
- A. Isometric
 - B. Orthographic
 - C. Topographic
 - D. View
- 5-4. What type of drawing is recommended for showing all pipes either straight or bent in more than one plane?
- A. Isometric
 - B. Orthographic
 - C. Topographic
 - D. View
- 5-5. On a drawing that shows the crossing of pipes, what indicates the pipe farthest from the viewer where the other pipe passes in front of it?
- A. Arrow
 - B. Break
 - C. Circle
 - D. Square
- 5-6. What Military Standard establishes the color code used to identify piping carrying hazardous fluids?
- A. 101
 - B. 303
 - C. 505
 - D. 707

- 5-7. What warning marking identifies materials that are extremely hazardous to life or health?
- A. AAHM
 - B. FLAM
 - C. PHDAN
 - D. TOXIC
- 5-8. What warning marking identifies a material that is NOT dangerous by itself, but is asphyxiating in confined areas?
- A. AAHM
 - B. FLAM
 - C. PHDAN
 - D. TOXIC
- 5-9. Standard symbols are generally NOT used in drawings of shipboard systems found in which of the following types of manuals?
- A. Operation and maintenance
 - B. Operation and supply
 - C. Supply and maintenance
 - D. Training and supply
- 5-10. What hydraulic line is also called a suction line?
- A. Operating
 - B. Pressure
 - C. Supply
 - D. Vent
- 5-11. What hydraulic line alternately carries pressure to an actuating unit and returns fluid from the actuating unit?
- A. Operating
 - B. Pressure
 - C. Supply
 - D. Vent
- 5-12. What hydraulic line carries excess fluid overboard or into another receptacle?
- A. Operating
 - B. Pressure
 - C. Supply
 - D. Vent

- 5-13. What American Society for Testing and Materials Standard lists the symbols used on hydraulic diagrams?
- A. 01-1A-17
 - B. 14105A
 - C. 803-50010149
 - D. F1000-13
- 5-14. On a hydraulic diagram, what markings indicate the direction of flow?
- A. Arrows
 - B. Circles
 - C. Diamonds
 - D. Squares
- 5-15. When interpreting piping designations of crosses and elbows, you should read what opening first?
- A. Largest
 - B. Smallest
 - C. The one facing left
 - D. The one facing right

RATE TRAINING MANUAL – User Update

SWOS makes every effort to keep their manuals up-to-date and free of technical errors. We appreciate your help in this process. If you have an idea for improving this manual, or if you find an error, a typographical mistake, or an inaccuracy in SWOS manuals, please write or e-mail us, using this form or a photocopy. Be sure to include the exact chapter number, topic, detailed description, and correction, if applicable. Your input will be brought to the attention of the Technical Review Committee. Thank you for your assistance.

Write: SWOS Project Manager
1534 Piersey Street Suite 321
Norfolk, VA 23511-2613
COMM: (757) 444-5332
DSN: 564-5332

E-mail: Refer to the SWOS Norfolk page on the NKO Web page for current contact information.

Rate_____ Course Name_____
Revision Date_____ Chapter Number_____ Page Number(s)_____
Description

(Optional) Correction

(Optional) Your Name and Address

CHAPTER 6

ELECTRICAL AND ELECTRONIC PRINTS

Electrical and electronic prints identify circuits, assemblies, and systems. The chapter discusses electrical and electronic prints and symbols commonly used for electrical and electronic drawings, and describes the common types of drawings used in the installation and troubleshooting of electrical systems on ships and aircraft.

LEARNING OBJECTIVES

When you have completed this chapter, you will be able to do the following:

1. Identify shipboard electrical and electronic prints.
2. Identify aircraft electrical and electronic prints.
3. Identify basic logic diagrams on blueprints.

ELECTRICAL PRINTS

A large number of ratings may use Navy electrical prints to install, maintain, and repair equipment. In the most common examples, electrician's mates (EMs) and interior communications electricians (ICs) use them for shipboard electrical equipment and systems; construction electricians (CEs) use them for power, lighting, and communications equipment and systems ashore; and aviation electrician's mates (AEs) use them for aircraft electrical equipment and systems.

Types of Diagrams

These prints will make use of the various electrical diagrams defined in the following paragraphs.

Pictorial Diagram

Pictorial diagrams show a picture or sketch of the various components of a specific system and the wiring between these components. This simplified diagram provides the means to readily identify the components of a system by their physical appearance. This type of diagram shows the various components without regard to their physical location, how the wiring is marked, or how the wiring is routed.

Isometric Diagram

An isometric diagram is used in locating a component within a system. If it is not known where to look for a component, the isometric diagram is of considerable value. This type of diagram shows the outline of a ship, airplane, or piece of equipment. Within the outline are drawn the various components of a system in their respective locations.

Block Diagram

Block diagrams are used primarily to present a general description of a system and its functions. This type of diagram is generally used in conjunction with text material. A block diagram shows the major components of a system and the interconnections of these components. All components are shown in block form, and each block is labeled for identification purposes.

Single-Line Diagram

A single-line diagram is used basically for the same purpose as the block diagram. When used with text material, it gives a basic understanding of the functions of the components of a system. Two major differences exist between the single-line diagram and the block diagram. The first difference is that the single-line diagram uses symbols rather than labeled blocks to represent components. Second, the single-line diagram shows all components in a single line.

Schematic Diagram

A schematic diagram is a picture of a circuit that uses symbols to represent components in the circuit. Circuits that are physically large and complex can be shown on relatively small diagrams.

Wiring Diagram

A wiring diagram is a detailed diagram of each circuit installation showing all of the wiring, connectors, terminal boards, and electrical or electronic components of the circuit. It also identifies the wires by wire numbers or color coding. Wiring diagrams are necessary to troubleshoot and repair electrical or electronic circuits.

Before any blueprint can be read, the standard symbols for the type of print concerned must be familiar. To read electrical blueprints, various types of standard symbols and the methods of marking electrical connectors, cables, and equipment should be known.

Shipboard Electrical Prints

To interpret shipboard electrical prints, the graphic symbols for electrical diagrams and the electrical wiring equipment symbols for ships should be recognized. These graphic symbols are shown in Graphic Symbols for Electrical and Electronic Diagrams, Institute of Electrical and Electronic Engineers (IEEE) Standard 315A-1986 and Naval Ships' Technical Manual (NSTM) Chapter 320. In addition, the shipboard system of numbering electrical units and marking electrical cables, as described in the following paragraphs, should be familiar.

Numbering Electrical Units

All similar units in the ship comprise a group, and each group is assigned a separate series of consecutive numbers beginning with 1. Numbering begins with units in the lowest, foremost starboard compartment and continues with the next compartment to port if it contains familiar units; otherwise it continues to the next aft compartment on the same level.

Proceeding from starboard to port and from forward to aft, the numbering procedure continues until all similar units on the same level have been numbered. The numbering then continues on the next upper level and so on until all similar units on all levels have been numbered. Within each compartment, the numbering of similar units proceeds from starboard to port, forward to aft, and from a lower to a higher level.

Within a given compartment, the numbering of similar units follows the same rule; that is, lower takes precedence over upper; forward over aft; and starboard over port.

Electrical distribution panels, control panels, and so forth, are given identification numbers made up of three numbers separated by hyphens. The first number identifies the vertical level by deck or platform number at which the unit is normally accessible. Decks of Navy ships are numbered by using the main deck as the starting point as described in Basic Military Requirements, Naval Education Training Manual (NAVEDTRA) 14325. The numeral 1 is used for the main deck, and each successive deck above is numbered 01, 02, 03, and so on, and each successive deck below the main deck is numbered 2, 3, 4, and so on.

The second number identifies the longitudinal location of the unit by frame number. The third number identifies the transverse location by the assignment of consecutive odd numbers for centerline and starboard locations and consecutive even numbers for port locations. The numeral 1 identifies the lowest centerline (or centermost, starboard) component. Consecutive odd numbers are assigned components as they would be observed first as being above, and then outboard, of the preceding component. Consecutive even numbers similarly identify components on the portside. For example, a distribution panel with the identification number, 1-142-2, will be located on the main deck at frame 142, and will be the first distribution panel on the portside of the centerline at this frame on the main deck.

Main switchboards or switchgear groups supplied directly from ship's service generators are designated 1S, 2S, and so on. Switchboards supplied directly by emergency generators are designated 1E, 2E, and so on. Switchboards for special frequencies (other than the frequency of the ship's service system) have alternating current (ac) generators designated 1SF, 2SF, and so on.

Sections of a switchgear group (other than the generator section) are designated by an additional suffix letter starting with the letter A and proceeding in alphabetical order from left to right (viewing the front of the switchgear group). Some large ships are equipped with an electrical distribution system called zone distribution. In a zone distribution system, the ship is divided into areas generally coinciding with the fire zones prescribed by the ship's damage control plan. Electrical power is distributed within each zone from load center switchboards located within the zone. Load center switchboards and miscellaneous switchboards on ships with zone control distribution are given identification numbers, the first digit of which indicates the zone and the second digit the number of the switchboard within the zone as determined by the general rules for numbering electrical units.

Cable Marking

Metal tags embossed with the cable designations are used to identify all permanently installed shipboard electrical cables. These tags (*Figure 6-1*) are placed on cables as close as practical to each point of connection on both sides of decks, bulkheads, and other barriers. They identify the cables for maintenance and replacement. Navy ships use two systems of cable marking; an old color tag system and new sequential numbering system. An explanation of both systems is in the following paragraphs.

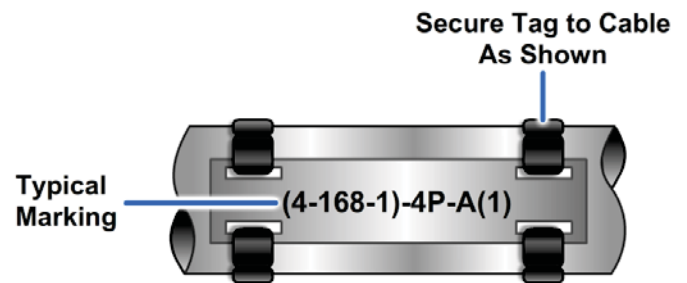

Figure 6-1 — Cable tag.

Old Cable Tag System—the color of the tag shows the cable classification: red—vital, yellow—semivital, and gray or no color—nonvital. The tags will contain the basic letters that designate power and lighting cables for the different services listed in *Table 6-1*:

Table 6-1 — Old Cable Service Identification Letters

SERVICES	DESIGNATIONS
Interior communications	C
Degaussing	D
Ship's service lighting and general power	F
Battle power	FB
Fire control	G
Minesweeping	MS

Table 6-1 — Old Cable Service Identification Letters (continued)

SERVICES	DESIGNATIONS
Electric propulsion	P
Radio and radar	R
Running, anchor, and signal lights	RL
Sonar	S
Emergency lighting and power	FE

Other letters and numbers are used with these basic letters to further identify the cable and complete the designation. Common markings of a power system for successive cables from a distribution switchboard to load would be as follows: feeders, FB-411; main, I-FB-411; submain, 1-FB-411A; branch, 1-FB-411A1; and sub-branch, I-FB-411-A1A. The feeder number 411 in these examples shows the system voltage. The feeder numbers for a 117- or 120-volt system range from 100 to 190; for a 220-volt system, from 200 to 299; and for a 450-volt system, from 400 to 499. The exact designation for each cable is shown on the ship's electrical wiring prints.

New Cable Tag System—consists of three parts in sequence. First is the service letter which identifies the particular electrical system. The second part is the circuit letter, which identifies the specific circuit within the particular system. The third part is the cable number, which identifies the individual cable in a specific circuit. These parts are separated by hyphens. The following table (*Table 6-2*) depicts the letters used to designate the different services:

Table 6-2 — New Cable Service Identification Letters

SERVICES	DESIGNATIONS
Cathodic protection	CPS
Control, power plant, and ship	K
Degaussing	D
Electronics	R
Fire control	G
Interior communications	C
Lighting, emergency	EL
Lighting, navigational	N
Lighting, ship service	L
Minesweeping	MS
Night flight lights	FL
Power, casualty	CP
Power, emergency	EP
Power, propulsion	PP
Power, ship service	P
Power, shore connections	PS
Power, special frequency	SF
Power, weapon system	WP
Power, weapon system, 400 Hz	WSF

Voltages below 100 are designated by the actual voltage; for example, 24 for a 24-volt circuit. For voltages above 100, the number 1 shows voltages between 100 and 199; the number 2, voltages between 200 and 299; the number 4, voltages between 400 and 499, and so on. For a three-wire

(120/240) direct current (dc) system or a three-wire, three-phase system, the number shows the higher voltage.

The destination of cable beyond panels and switchboards is not designated except that each circuit alternately receives a letter, a number, a letter, and a number progressively every time it is fused. The destination of power cables to power-consuming equipment is not designated except that each cable to such equipment receives a single-letter alphabetical designation beginning with the letter A.

Where two cables of the same power or lighting circuit are connected in a distribution panel or terminal box, the circuit classification is not changed. However, the cable markings have a suffix number in parentheses indicating the section. For example, *Figure 6-1* shows that (4-168-1)-4P-A(1) identifies a 450 volt power cable supplied from a power distribution panel on the fourth deck at frame 168 starboard. The letter A indicates the first cable from the panel and the (1) indicates the first section of a power main with more than one section.

The power cables between generators and switchboards are labeled according to the generator designation. When only one generator supplies a switchboard, the generator will have the same number as the switchboard plus the letter G. Thus, 1SG identifies one ship's service generator that supplies the number 1 ship's service switchboard. When more than one ship's service generator supplies a switchboard, the first generator determined according to the general rule for numbering machinery will have the letter A immediately following the designation. The second generator that supplies the same switchboard will have the letter B. This procedure is continued for all generators that supply the switchboard, and then is repeated for succeeding switchboards. Thus, 1SGA and 1SGB identify two service generators that supply ship's service switchboard 1S.

Phase and Polarity Markings

Three phase sequence are on board Navy ships, A, B, and C. Phase and polarity in the ac electrical systems are designated by a wiring color code as shown in *Table 6-3*. Neutral polarity, where it exists, is identified by the green conductor.

Table 6-3 — Color Coding on Three-Phase ac Systems

Cable Type	Phase or Polarity	Color Code
4 Conductor	A	Black
	B	White
	C	Red
	Neutral	Green
3 Conductor	A	Black
	B	White
	C	Red

Isometric Wiring Diagram

An isometric wiring diagram is supplied for each shipboard electrical system. If the system is not too large, the diagram will be on one blueprint while larger systems may require several prints. An isometric wiring diagram shows the ship's decks arranged in tiers. It shows bulkheads and compartments, a marked centerline, frame numbers usually every five frames, and the outer edge of each deck in the general outline of the ship. It shows all athwart ship lines at an angle of 30 degrees to the centerline. Cables running from one deck to another are drawn as lines at right angles to the centerline. A single line represents a cable regardless of the number of conductors. The various electrical fixtures are identified by a symbol number and their general location is shown. Therefore, the isometric wiring diagram shows a rough picture of the entire circuit layout.

All electrical fittings and fixtures shown on the isometric wiring diagram are identified by a symbol number. The symbol number is taken from the Graphic Symbols for Electrical and Electronics Diagrams, IEEE Standard 315A-1986. This publication contains a complete list of standard symbol numbers for the various standard electrical fixtures and fittings for shipboard applications.

Cables shown on the isometric wiring diagram are identified by the cable marking system. In addition, cable sizes are shown in circular mils and number of conductors. Letters show the number of conductors in a cable; S for one-, D for two-, T for three-, and F for four-conductor cables. The number following the letter denotes the wire's circular mil area in thousands. For example, a cable supplying distribution box is marked (2-38-1)-1L-C1-T-9. This marking identifies a three-conductor, 9,000-circular mil, 120-volt, ship's service submain lighting cable supplied from panel 2-38-1.

Remember, the isometric wiring diagram shows only the general location of the various cables and fixtures. Their exact location is shown on the wiring plan discussed briefly in the next paragraphs.

Wiring Deck Plan

The wiring deck plan is the actual installation diagram for the deck or decks shown and is used chiefly in ship construction. It helps the shipyard electrician lay out his or her work for a number of cables without referring to individual isometric wiring diagrams. The plan includes a bill of material that lists all materials and equipment necessary to complete installation for the deck or decks concerned. Equipment and materials, except cables, are identified by a symbol number both on the drawing and in the bill of material.

Wiring deck plans are drawn to scale (usually 1/4 inch to the foot), and they show the exact location of all fixtures. One blueprint usually shows from 150 to 200 feet of space on one deck only. Electrical wiring equipment symbols from IEEE Standard 315A-1986 are used to represent fixtures just as they do in the isometric wiring diagram.

Electrical System Diagrams

Navy ships have electrical systems that include many types of electrical devices and components. These devices and components may be located in the same section or at various locations throughout the ship. The electrical diagrams and drawings necessary to operate and maintain these systems are found in the ship's electrical blueprints and in drawings and diagrams in Naval Sea Systems Command (NAVSEA) and manufacturers' technical manuals.

Block Diagram—is a simple drawing showing the relationships of major parts of a wiring circuit or system. A block diagram of a motor control system is illustrated in *Figure 6-2*. It is easy to see how it gets its name. Sometimes the blocks are connected by only one line that may represent one or more conductors or cables. Blocks may represent major or minor components or parts. This type of diagram is often used to show something of the relationship of components in a power distribution system. The block diagram provides little help in troubleshooting.

Wiring Diagram—is almost a picture drawing. It shows the wiring between components and the relative position of the components. *Figure 6-3* shows a wiring diagram of the same motor control system represented by the block diagram in *Figure 6-2*. In the wiring diagram,

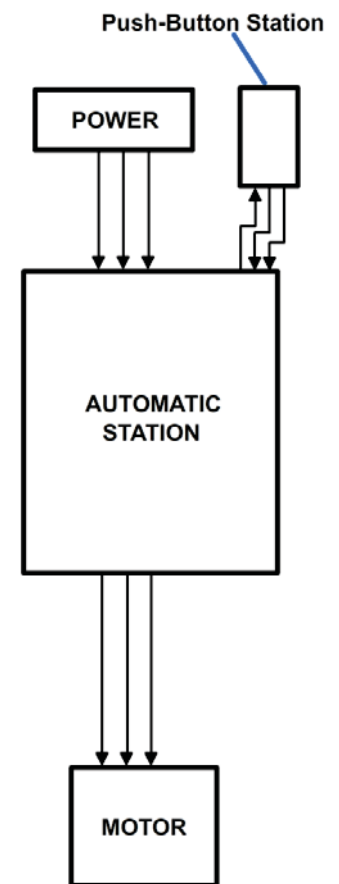

Figure 6-2 — Block diagram.

components are shown much as they would appear in a picture. The lines representing wires are marked with numbers or letter-number combinations.

Lines L1, L2, and L3 are incoming power leads. The diagram shows which terminals these power leads are connected to in the motor starter. Leads connected to terminals T1, T2, and T3 are the motor leads. The numbers without letters mark the control terminals of the starter. Wiring diagrams are often used along with a list of repair parts. Wiring diagrams may be of some help in troubleshooting circuit problems.

Connection Diagram—*Figure 6-4* is a combination of basic symbols (like the open-contact symbol). The controller pictured in *Figure 6-3* works internally.

The connection diagram shows all the internal and external connections. The circuitry can be traced more easily on it than on the wiring diagram. The components are still shown in their relative positions. This diagram can be used to help connect all the wiring and trace any part of the circuit. The connection diagram is a valuable troubleshooting tool. This type of diagram is often found inside the access cover of a piece of equipment.

Schematic Diagram or Elementary Diagram—is a drawing that shows the electrical connections and functions of a specific circuit arrangement. It facilitates tracing the circuit and its functions without regard to the physical size, shape, or relative position of the component device or parts. The schematic diagram (*Figure 6-5*), like the connection diagram, makes use of symbols instead of pictures. *Figure 6-5* shows, by a schematic diagram, the same motor control system shown in *Figures 6-2, 6-3, and 6-4*. This diagram is laid out in a way that makes the operation of the components easy to understand. This type of schematic diagram with the components laid out in a line is sometimes called a one line or single-line diagram.

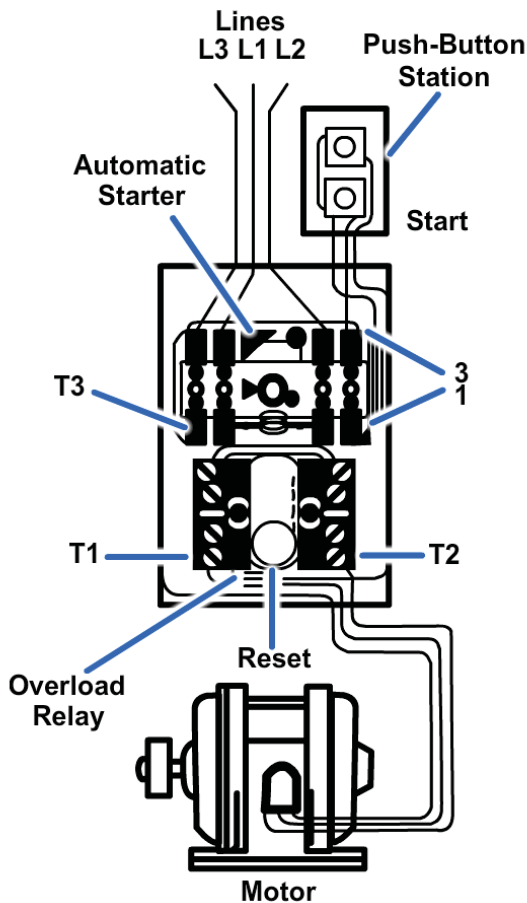

Figure 6-3 — Wiring diagram.

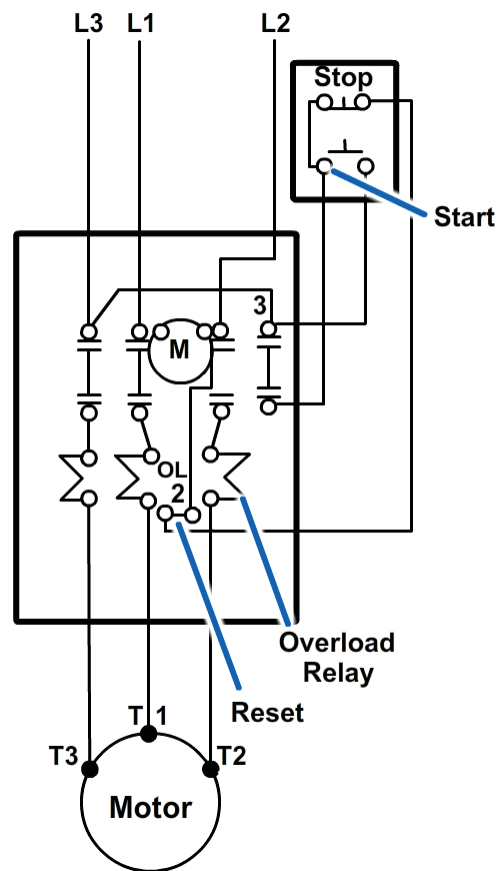

Figure 6-4 — Connection diagram.

Most schematic diagrams are more complicated than the one shown in *Figure 6-5*. The more complicated ones can be broken down into one-line diagrams, circuit by circuit. A one-line diagram can be drawn (or sketched freehand) by tracing only one circuit, component by component, through a multicircuit schematic. Circuits "S" and "M" in *Figure 6-6* show only the control circuit from *Figure 6-4* laid out in one-line form. From these simple circuits, it is easy to see that as soon as the start button is pushed, the "M" coil (operating coil of the motor controller) will be energized. The operating coil is now held closed through the "M" contacts.

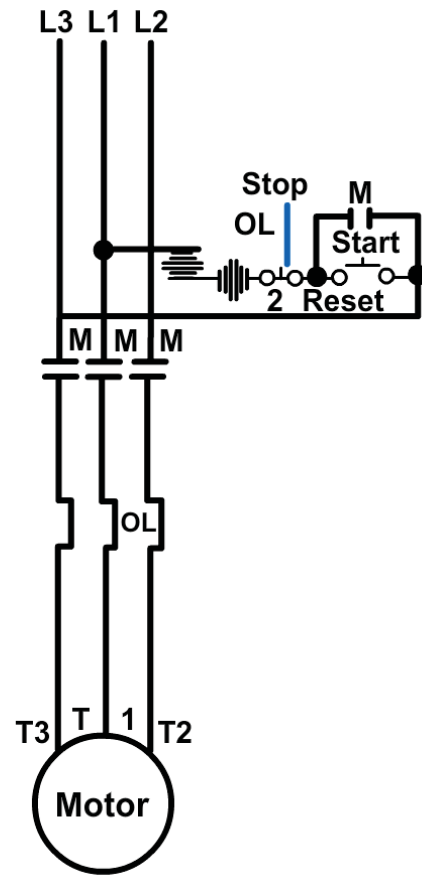

Figure 6-5 — Schematic diagram.

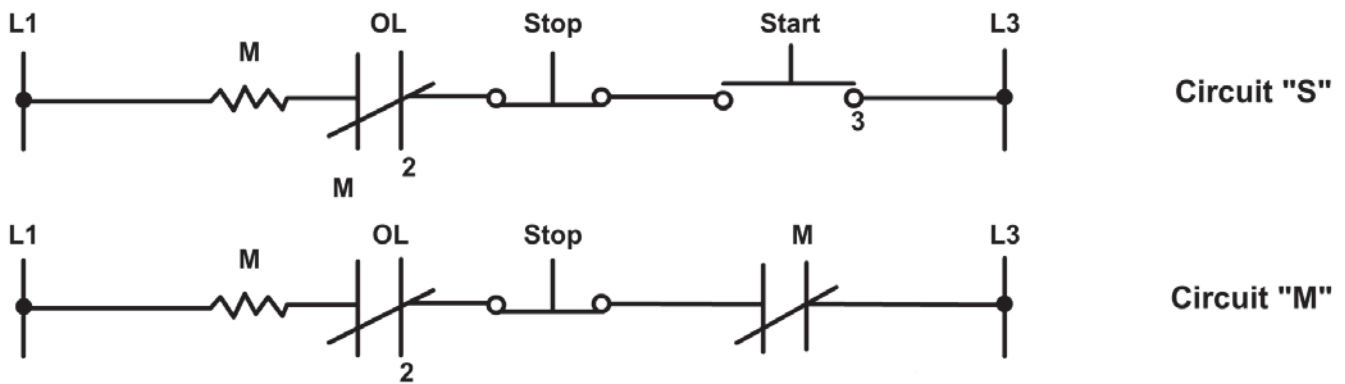

Figure 6-6 — One-line diagram of a motor control circuit.

Aircraft Electrical Prints

Aircraft electrical prints include schematic diagrams and wiring diagrams (Figure 6-7). Schematic diagrams show electrical operations. They are drawn in the same manner and use the same graphic symbols from IEEE Standard 315A-1986 as shipboard electrical schematics.

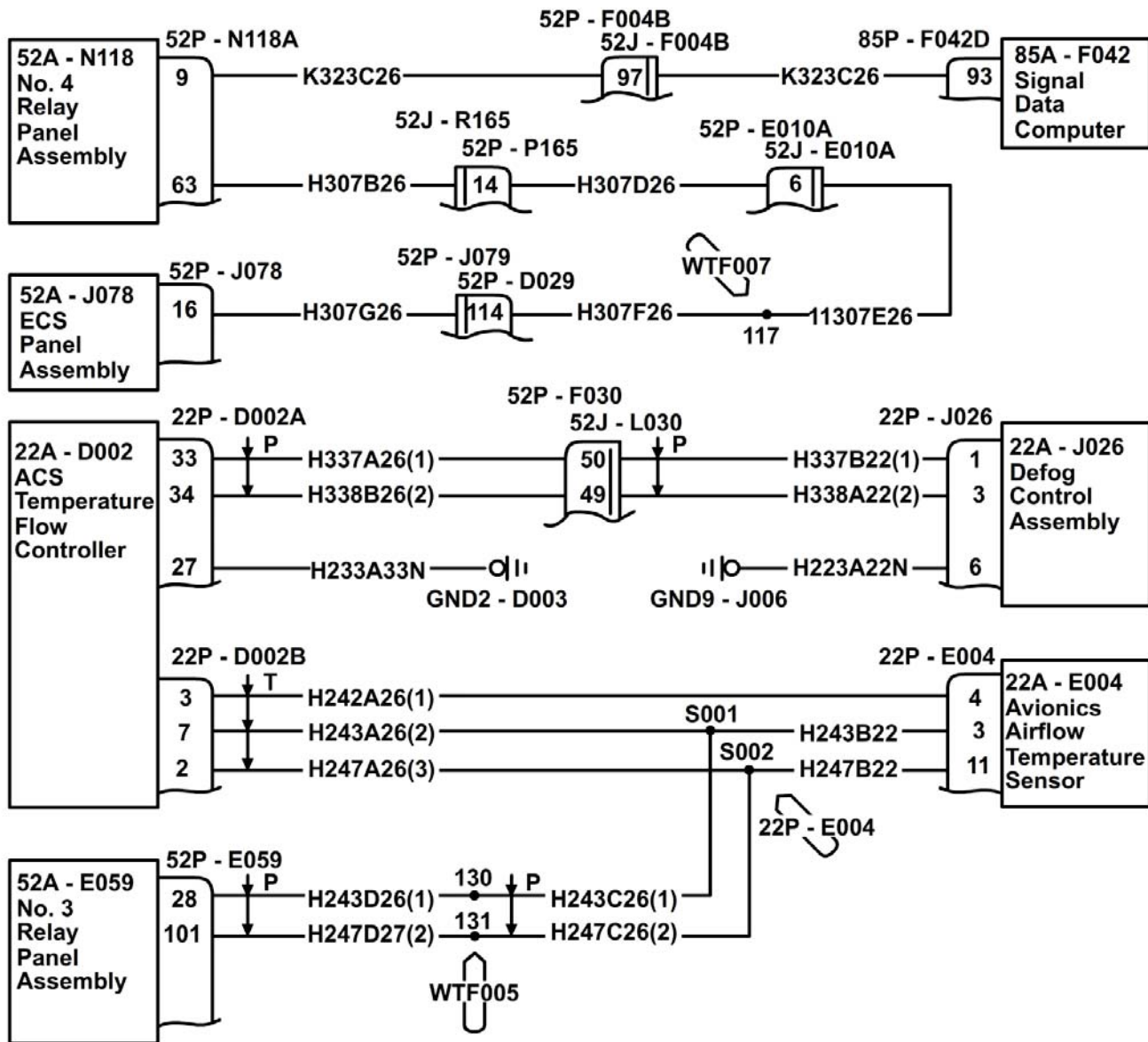

Figure 6-7 — Fighter/Attack (F/A)-18 aircraft electrical system.

Aircraft electrical wiring diagrams show detailed circuit information on all electrical systems. A master wiring diagram is a single diagram that shows all the wiring in an aircraft. In most cases these would be so large as to be impractical; therefore, they are broken down into logical sections such as the dc power system, the ac power system, and the aircraft lighting system.

Diagrams of major circuits generally include an isometric shadow outline of the aircraft showing the location of items of equipment and the routing of interconnecting cables. This diagram is similar to a shipboard isometric wiring diagram.

The simplified wiring diagram may be further broken down into various circuit wiring diagrams showing in detail how each component is connected into the system. Circuit wiring diagrams show

equipment part numbers, wire numbers, and all terminal strips and plugs just as they do on shipboard wiring diagrams.

Aircraft Wire and Cable Identification

To make aircraft maintenance easier, each connecting wire or cable in an aircraft has identification marked on it. The identification is a combination of letters and numbers. The marking identifies the circuit that the wire or cable belongs to, the gauge size of the wire or cable, and the information that relates the wire or cable to a wiring diagram. This marking uses the wire or cable identification code. Details of the wire and cable identification system can be found in Military Specification: Wiring, Aerospace Vehicle, SAE-AS50881.

NOTE

For an in-depth study of aircraft wiring specifications, limitations, and repair, refer to the Naval Air Systems Command (NAVAIR) Manual 01-1A-505 and NAVEDTRA 14318 Aviation Electricity Electronics Maintenance Fundamentals.

The basic wire identification code for circuits is read from left to right (*Figure 6-8*).

The first character in the alphanumeric code is a prefix (numeral), and is referred to as the unit number. The unit number is used only in those cases where more than one unit is installed in an identical manner in the same equipment. The wiring concerned with the first unit bears the prefix 1, and corresponding wires for the second unit have exactly the same designation, except for the prefix 2. In the wire identification code shown in *Figure 6-8*, the 2 denotes that it is the second of at least two identical systems in the equipment.

The letter following the prefix number identifies the circuit function. Function letters *D*, *E*, *L*, *P*, *V*, and *X* should be the primary concern. The letter *D* denotes instruments; *E* denotes engine instruments; *L* denotes lighting; *P* denotes dc power; *V* denotes dc power and dc control for ac systems; and *X* denotes ac power. These are identified in the wiring circuit function code.

The wire number that follows the circuit function consists of one or more digits and differentiates between wires in a circuit/circuits. A different number is used for wires that do not have a common terminal or connection, such as through a circuit breaker, switching device, or load.

Wires that are segmented by the use of connectors or terminals are given different segment letters. Normally, the segment letters are in alphabetical

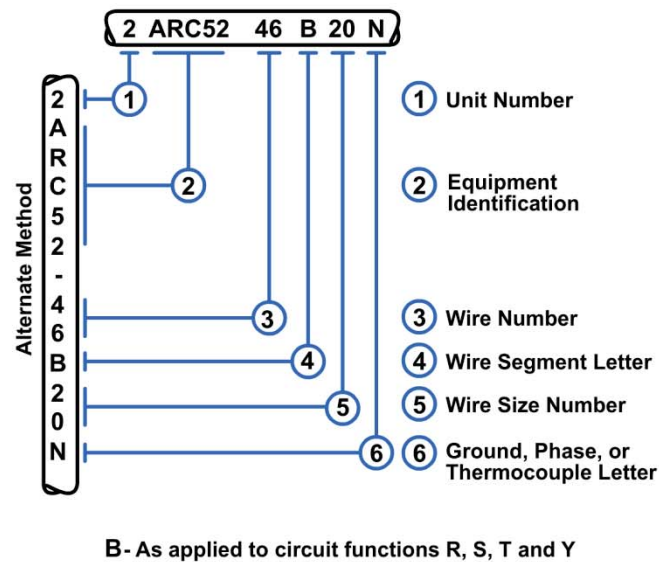
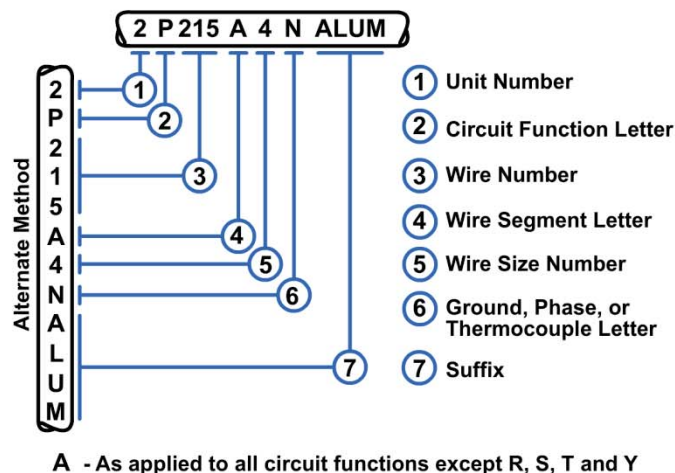

Figure 6-8 — Alphanumeric wire identification code.

sequence, beginning at the power source. The letters *I* and *O* are not used because they could be mistaken for the numerals 1 and 0. In the code shown in *Figure 6-8*, the letter *A* signifies the first segment of wire 215. The number following the segment letter identifies the size of the wire or cable.

The ground, phase, or thermocouple letter following the wire size number is used only when the segment of wire pertains to one of these items. The letters *N*, *A*, *B*, and *C* should be the primary concern. The letter *N* denotes a neutral wire; *A*, *B*, and *C* denote the three separate phases of an ac power supply or source.

The suffix letters at the end of the code are an abbreviation of the material of which the wire is made. For example, ALUM indicates the wire is made of aluminum.

Electrical circuit function letters and associated circuits are listed in *Table 6-4*.

Table 6-4 — Circuit Function Letters

Circuit Function Letter	Circuit
A	Armament
B	Photographic
C	Control surface
D	Instrument (other than flight or engine instruments)
E	Engine instrument
F	Flight instrument
G	Landing gear, wing fold
H	Heating, ventilation, and de-icing
I	To avoid confusion with the numeral one, the letter I shall not be used for circuit or cable identification
J	Ignition
K	Engine control
L	Lighting (illumination)
M	Miscellaneous (electrical)
N	Unassigned
O	To avoid confusion with the numeral zero, the letter O shall not be used for circuit or cable identification
P	Direct current (dc) power
Q	Fuel and oil
R	Radio (navigational and communication)
S	Radar (pulse technique)
T	Special electronics
U	Miscellaneous (electronic)
V	Both dc power and dc control cables for alternating current (ac) systems shall be identified by the circuit function letter V
W	Warning and emergency (except those listed under other circuit functions)
X	ac power
Y	Armament special equipment (except those listed under the circuit function A)
Z	Experimental circuits

ELECTRONIC PRINTS

Electronics prints are similar to electrical prints, but they are usually more difficult to read because they represent more complex circuitry and systems. Common types of shipboard and aircraft electronic prints and basic logic diagrams are discussed in the following sections.

Shipboard Electronics Prints

Shipboard electronics prints include isometric wiring diagrams that show the general location of electronic units and the interconnecting cable runs, and elementary wiring diagrams that show how each individual cable is connected.

Cables that supply power to electronic equipment are tagged as explained in the cable marking section. However, cables between units of electronic equipment are tagged with electronic designations. A partial listing of the electronic designations is listed in *Table 6-5*. The circuit or system designation shall be selected from the general specifications for ships of the Navy.

Cables between electronic units are tagged to show the system with which the cable is associated and the individual cable number. For example, in the cable marking R-ES4, the R identifies an electronic circuit, ES identifies the circuit as a surface search radar circuit, and 4 identifies the cable number. If a circuit has two or more cables with identical designations, a circuit differentiating number is placed before the R, such as 1R-ES4, 2R-ES4, and so on.

Table 6-5 — Electronic Circuit and System Designations

Circuit or System Designation	Circuit or System Title
R-AW	Meteorological circuits
R-BC	Radio beacons
R-BN	Radar beacons
R-CS	Sonar countermeasures system
R-DC	Radar and sonar data converters
R-DD	Data, digital
R-ED	Radar identification
R-ES	Surface search radars
R-ET	Radar trainer
R-MC	Missile control
R-MF	Drone control
R-TM	Television, monitoring
R-TV	Television, entertainment

Block Diagrams

Block diagrams describe the functional operation of an electronics system in the same way they do in electrical systems. In addition, some electronics block diagrams provide information useful in troubleshooting, which will be discussed later.

A simplified block diagram is usually shown first, followed by a more detailed block diagram. A simplified block diagram of the general announcing system, circuit 1MC, and the intership announcing system, circuit 6MC, is shown in *Figure 6-9*.

The system provides a means of transmitting general orders, information, and alarm signals to various locations simultaneously by microphones and loudspeakers connected through a central amplifier.

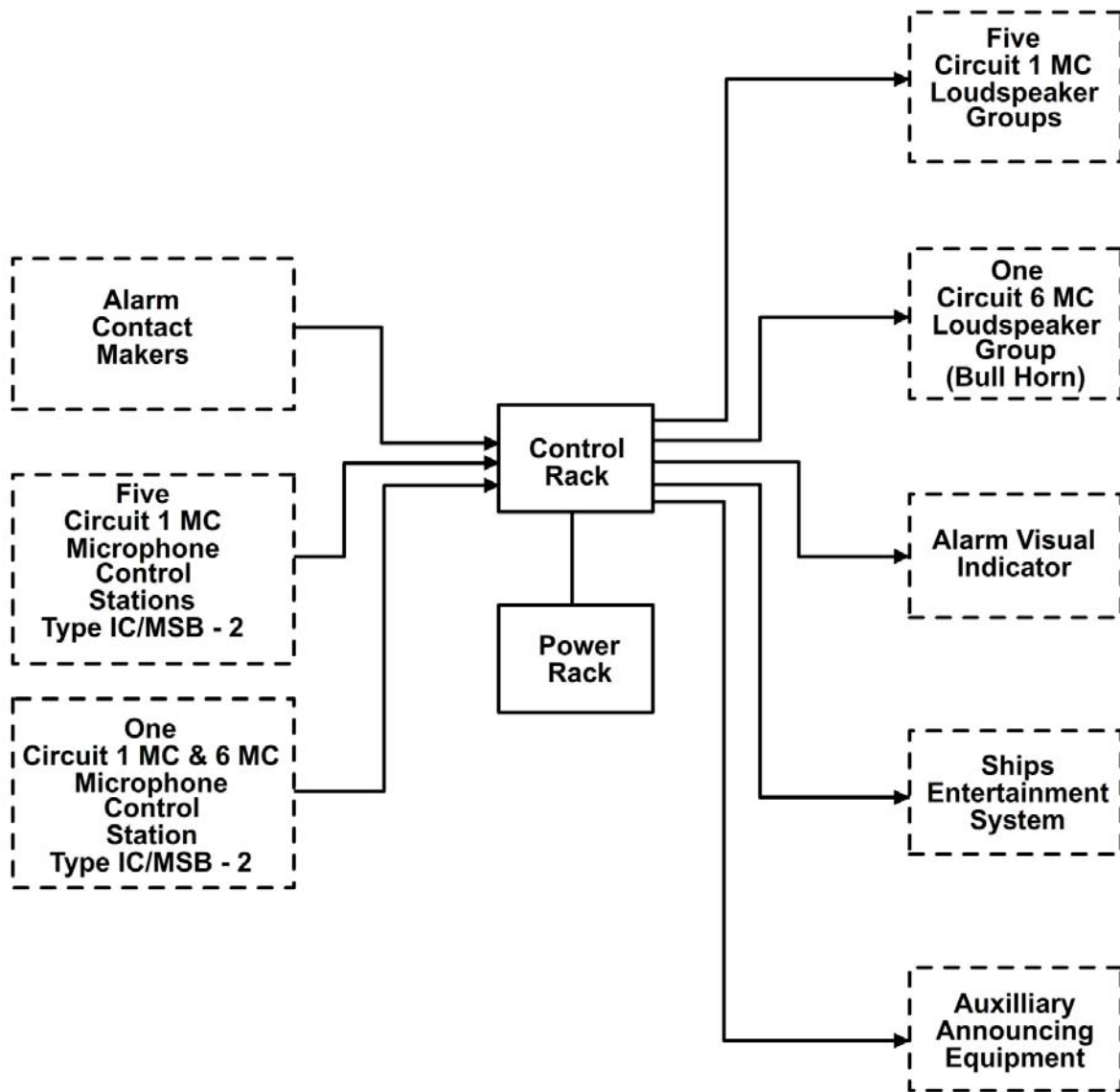

Figure 6-9 — Shipboard general and intership announcing system, simplified block diagram.

Graphic electrical and electronic symbols are frequently used in functional and detailed block diagrams of electronic systems to present a better picture of how the system functions.

Detailed block diagrams can be used to isolate a trouble to a particular assembly or subassembly. However, schematic diagrams are required to check the individual circuits and parts.

Schematic Diagrams

Electronic schematic diagrams use graphic symbols from IEEE Standard 315A-1986 for all parts, such as tubes, transistors, capacitors, and inductors. Simplified schematic diagrams are used to show how a particular circuit operates electronically. However, detailed schematic diagrams are necessary for troubleshooting.

A detailed schematic diagram of the salinity indicator system is shown in *Figure 6-10*. It shows most of the components are numbered. In an actual detailed schematic, however, all components are identified by a letter and a number and their values are given. All tubes and transistors are identified by a letter and a number and also by type.

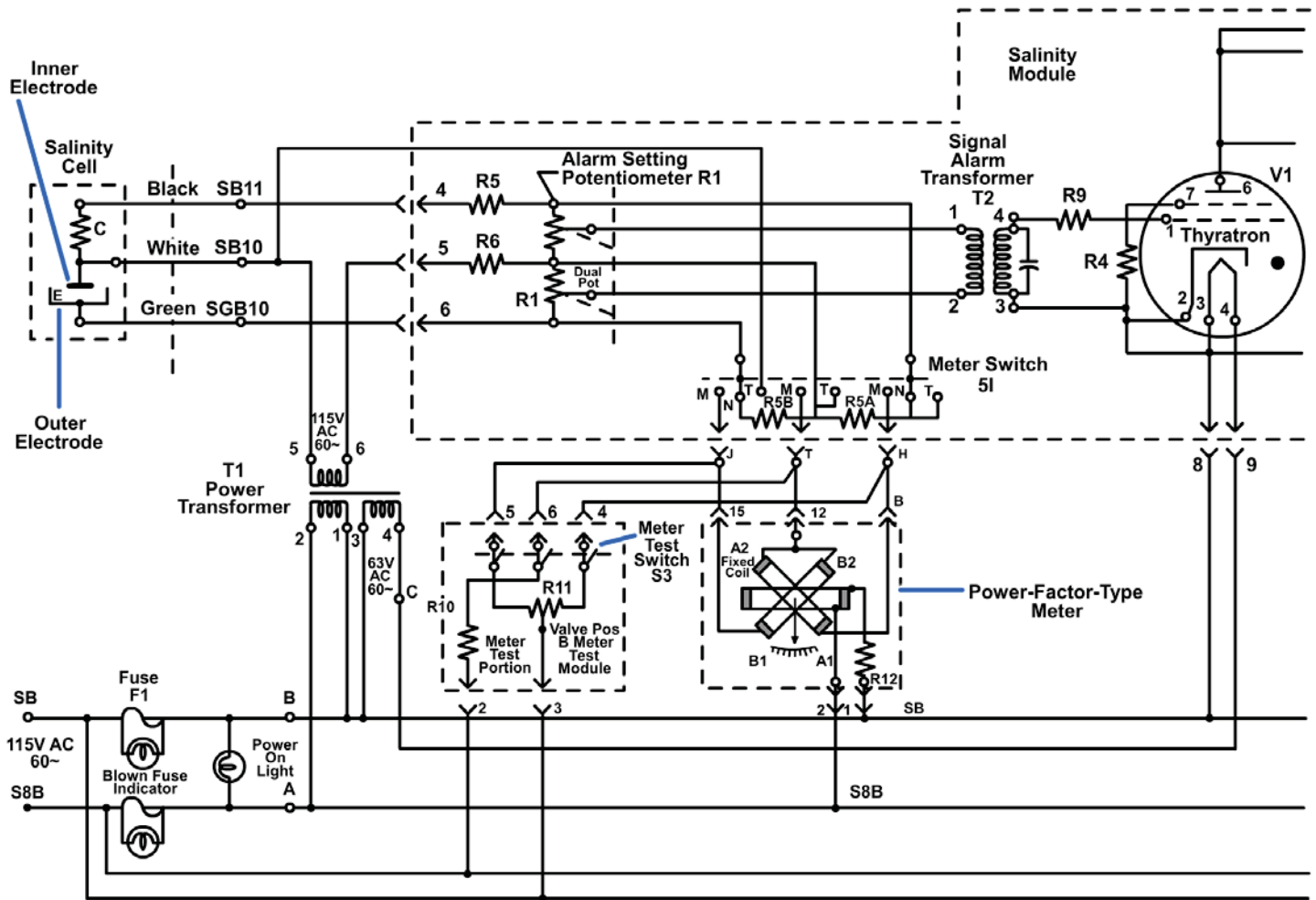

Figure 6-10 — Schematic diagram of a salinity indicator system.

Wiring Diagrams

Electronic equipment wiring diagrams show the relative positions of all equipment parts and all electrical connections. All terminals, wires, tube sockets, resistors, capacitors, and so on are shown as they appear in the actual equipment. A sample wiring diagram for three-phase distribution is illustrated in *Figure 6-11*.

The basic wiring color codes for electronics are listed in *Table 6-6*.

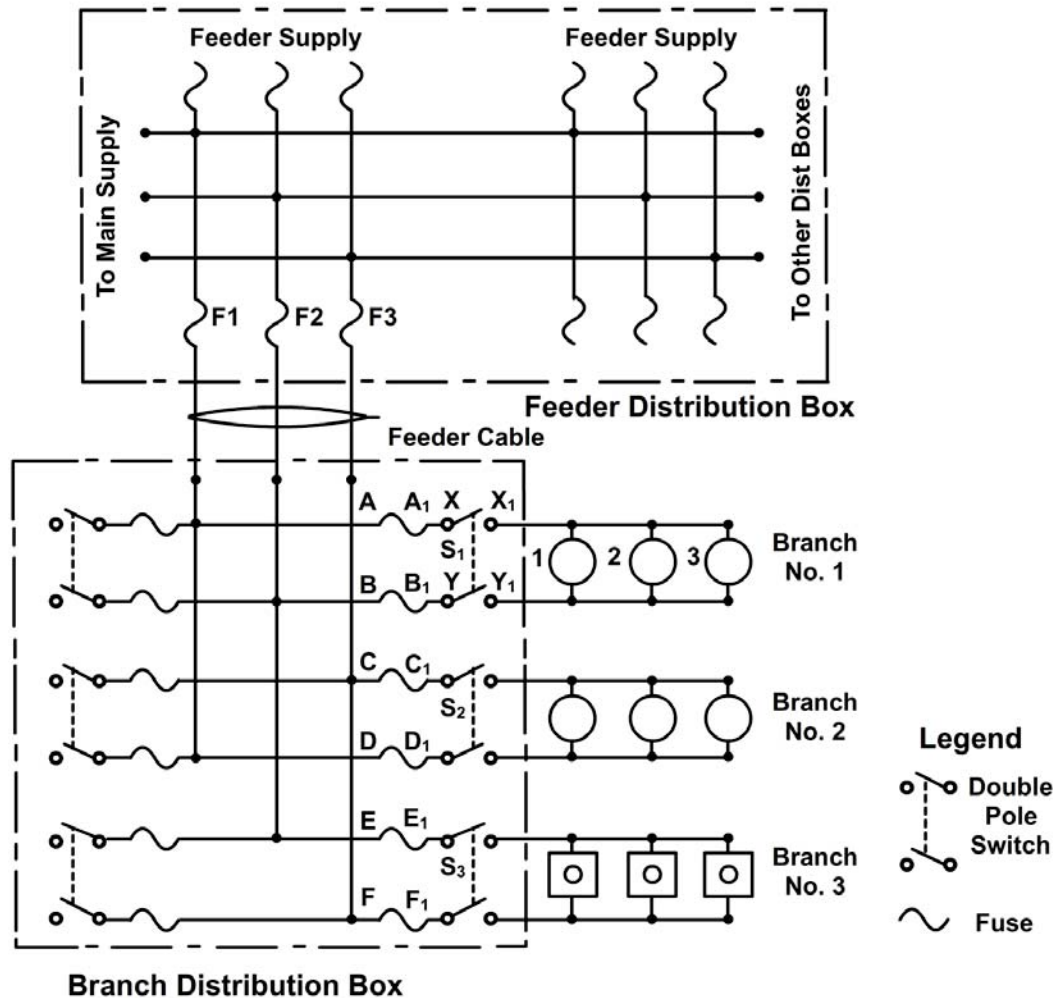

Figure 6-11 — Three-phase distribution wiring diagram.

Table 6-6 — Basic Wiring Color Codes

CIRCUIT	COLOR
Grounds, grounded elements, and returns	Black
Heaters or filaments, off ground	Brown
Power supply	Red
Screen grids	Orange
Emitters/cathodes	Yellow
Bases/control grids	Green
Collectors/plates	Blue
Power supply	Violet (purple)
Alternating current power lines	Gray
Miscellaneous, above or below ground returns, automatic volume control (AVC)	White

Reference Designations

A reference designation is a combination of letters and numbers used to identify the various parts and components on electronic drawings, diagrams, parts lists, and so on. The work prints will have one of two systems of reference designations. The old one is called a block numbering system and is no longer in use. Although, some older prints may have the old block numbering system. The current one is called a unit numbering system. Both will be discussed in the following paragraphs.

Block Numbering System—has a letter identifying the class, to which a part belongs, such as R for resistor, C for capacitor, V for electron tube, and so on. A number identifies the specific part and in which unit of the system the part is located. Parts within each class in the first unit of a system are numbered consecutively from 1 through 199; parts in the second unit from 201 through 299; and so on.

Unit Numbering System—is the currently used reference designation system. Electronic systems are broken into sets, units, assemblies, subassemblies, and parts (*Figure 6-12*). A system is defined as two or more sets and other assemblies, subassemblies, and parts necessary to perform an operational function or functions. A set is defined as one or more units and the necessary assemblies, subassemblies, and parts connected or associated together to perform an operational function.

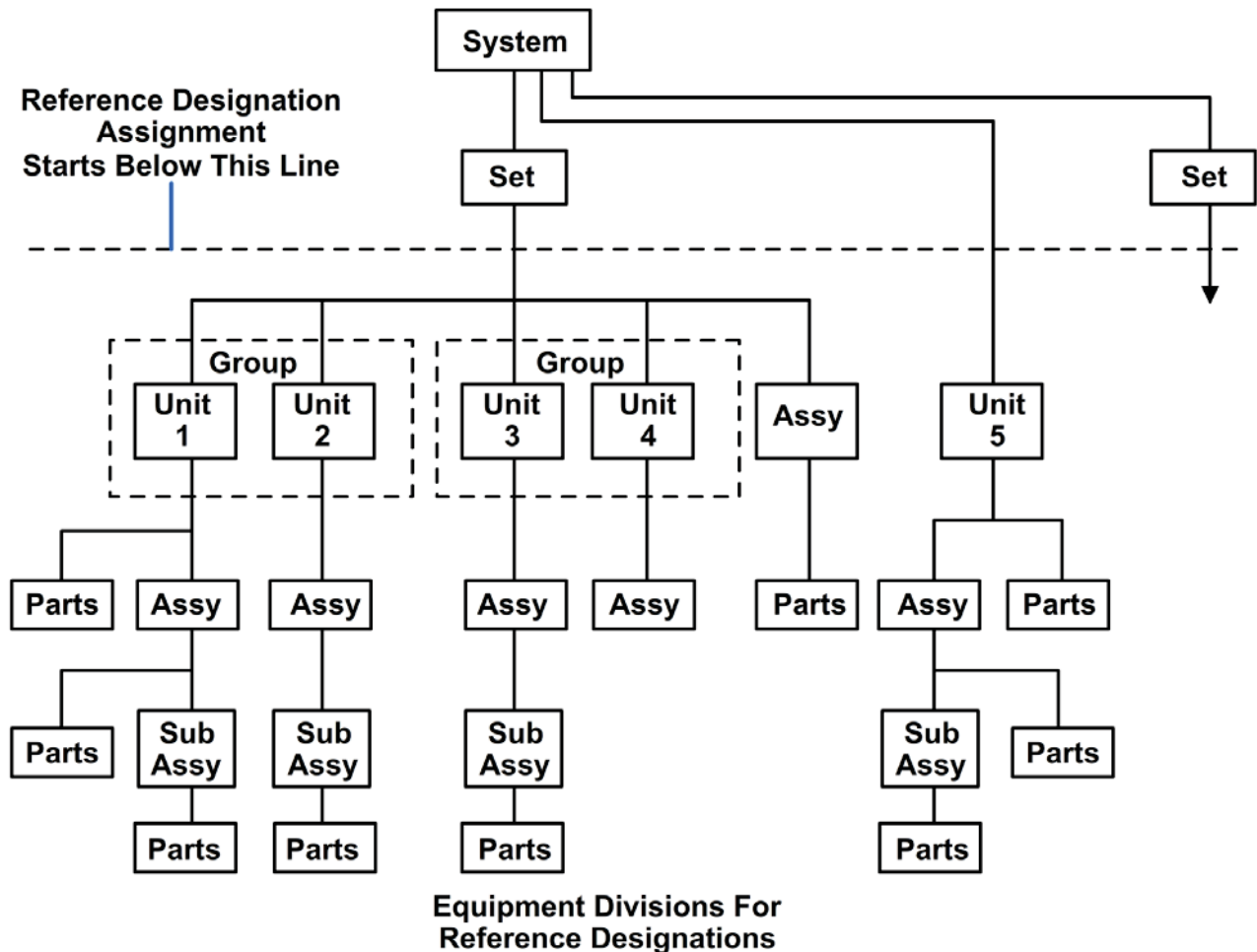

Reference Designations are Always Assigned Down to Lowest Level (Parts). The Final Wired Cabinet is the Unit.

Figure 6-12 — System subdivision.

Reference designations are assigned beginning with the unit and continuing down to the lowest level (parts). Units are assigned a number beginning with 1 and continuing with consecutive numbers for all units of the set. The number is a complete reference designation for the unit. If there is only one unit, the unit number is omitted.

Assemblies and subassemblies form a portion of a unit. The assemblies and subassemblies can be replaced as a whole or individual parts are replaceable. The distinction between an assembly and a subassembly is not always exact; an assembly in one application may be a subassembly in another when it forms a portion of an assembly.

By examining the reference designator of a unit, it will be possible to determine in which group, if any, the unit is contained. A good example to break down and identify a complete reference designator for a unit is the reference designator 2A2A3C1 on *Figure 6-13*.

The first indicator, 2, is numeric and refers to unit 2. The next indicator, A2, is alphanumeric and refers to assembly A2. The next indicator, A3, is also alphanumeric and refers to subassembly A3. The last indicator, C1, like the two previous, is alphanumeric and refers to the part C1. This means capacitor C1 is on subassembly A3, which is on assembly A2, which is in unit 2 of the equipment.

Reference designations may be expanded or reduced to as many levels required to identify a particular part. In *Figure 6-13* the designator 2J1 identifies jack J1, which is mounted directly on unit 2. The designator 2A4C3 identifies capacitor C3, which is on assembly A4 in unit 2.

On electronic diagrams, the usual procedure is to use partial (abbreviated) reference designations (*Figure 6-14*). In this procedure, only the letter and number identifying the part is shown on the part

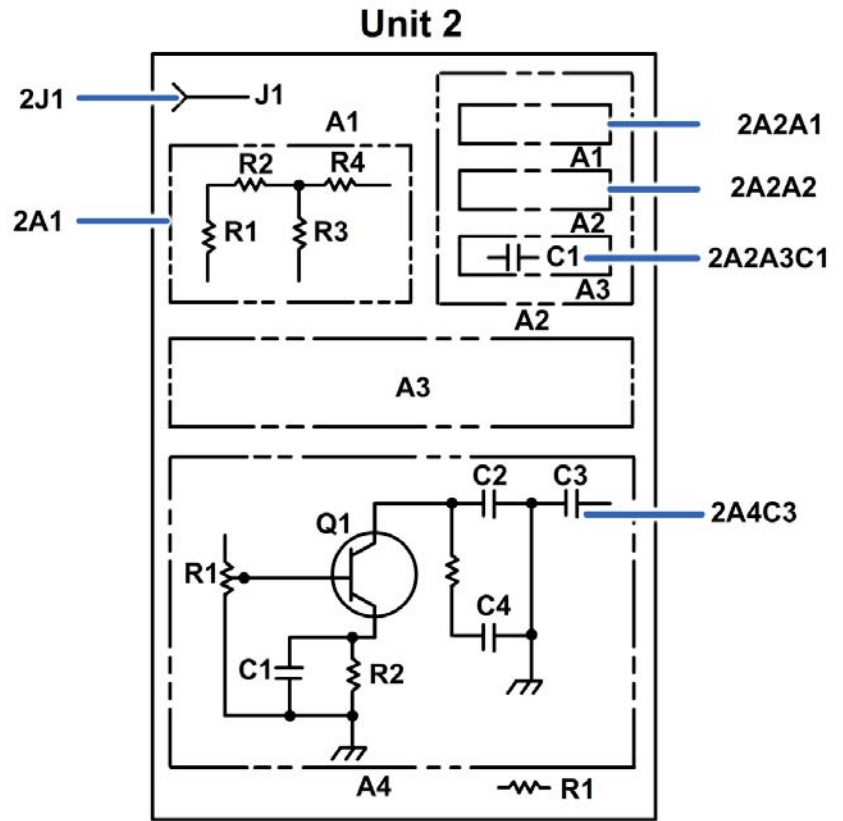

Figure 6-13 — Reference designation.

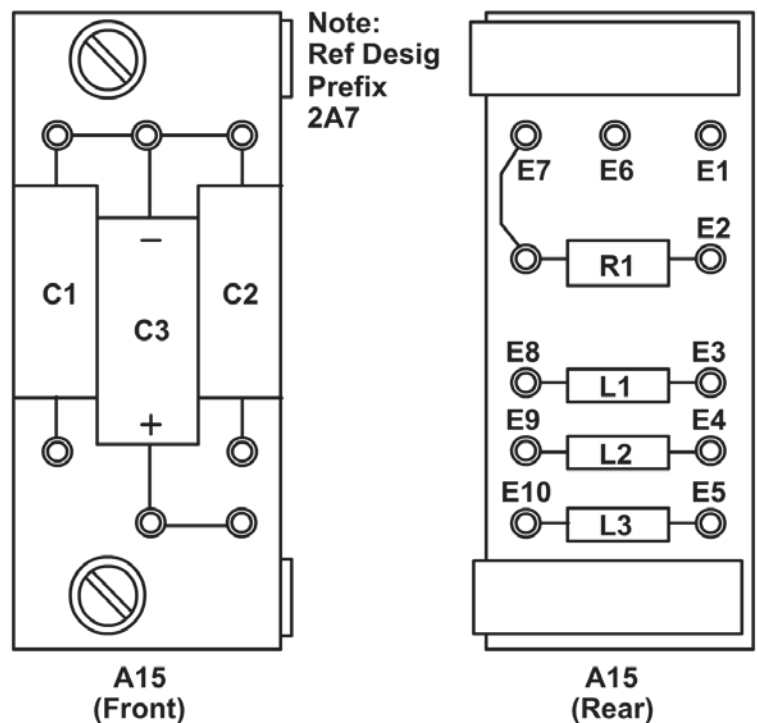

Figure 6-14 — Application of reference designations.

Individual conductors connecting to terminal boards are tagged with a vinyl sleeving called spaghetti that shows the terminal board and terminal to which the outer end of the conductor is connected. The sleeving is marked with identifying numbers and letters and then slid over the conductor (*Figure 6-16*). The marking on the sleeving identifies the conductor connections both "to" and "from" by giving the following information:

- The terminal "from."
- The terminal board "to."
- The terminal "to."

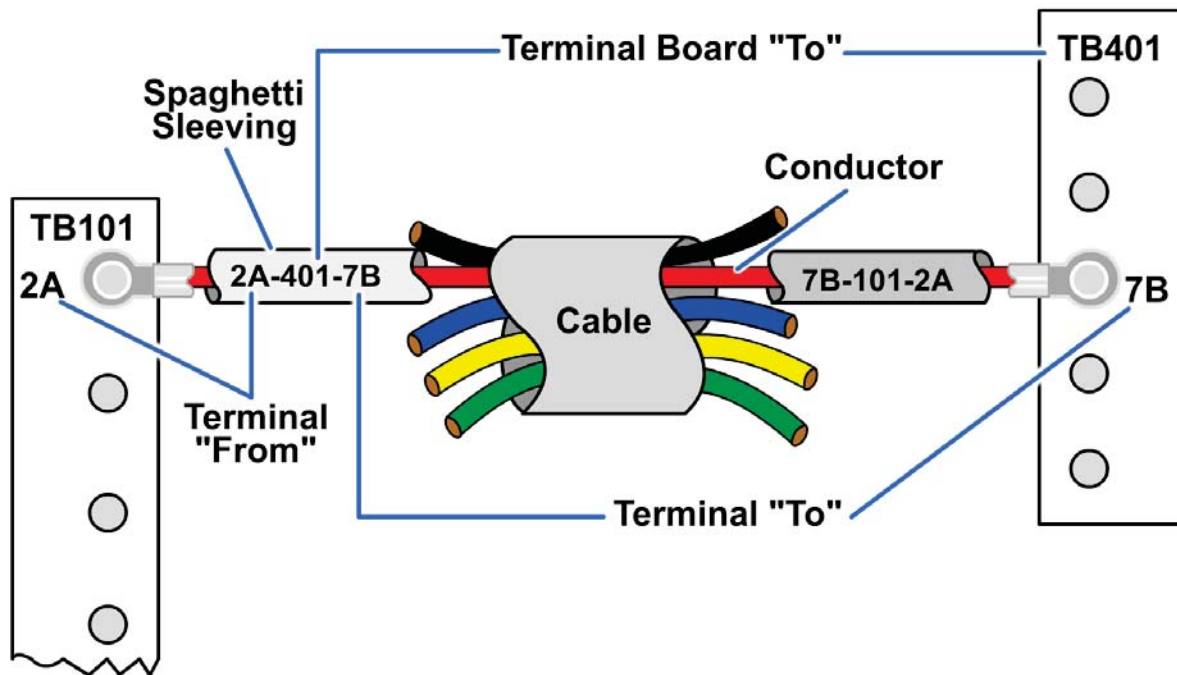

Figure 6-16 — Designating conductor marking between unlike terminals.

The designations on the sleeving are separated by a dash. The order of the markings is such that the first set of numbers and letters reading from left to right is the designation corresponding to the terminal "from" which the conductor runs. Following this number is the number of the terminal board "to" which the conductor runs. ("TB" is omitted when the sleeve is marked.) The third designation is the terminal "to" which the conductor runs.

For example, as shown in *Figure 6-16*, the conductor is attached to terminal 2A of terminal board 101 (terminal "from" 2A on the spaghetti sleeving). The next designation on the sleeving is 401, indicating it is going "to" terminal board 401. The last designation is 7B, indicating it is attached "to" terminal 7B of TB 401. The spaghetti marking on the other end of the conductor is read the same way. The conductor is going "from" terminal 7B on terminal board 401 "to" terminal 2A on terminal board 101.

Aircraft Electronics Prints

Aircraft electronics prints include isometric wiring diagrams of the electronics systems showing the locations of the units of the systems and the interconnecting wiring. Both simplified and detailed block and schematic diagrams are used. They show operation and serve as information for maintenance and repair in the same way as those in shipboard electronics systems. Detailed block diagrams of

complicated systems that contain details of signal paths, wave shapes, and so on are usually called signal flow diagrams.

Wiring Diagrams

Aircraft electronic wiring diagrams fall into two basic classes: wiring diagrams and interconnecting diagrams. There are many variations of each class, depending on the application.

The diagram in *Figure 6-17* shows the wiring interconnections to other components. It does not show the actual positioning of circuit components, and it shows wire bundles as single lines with the separate wires.

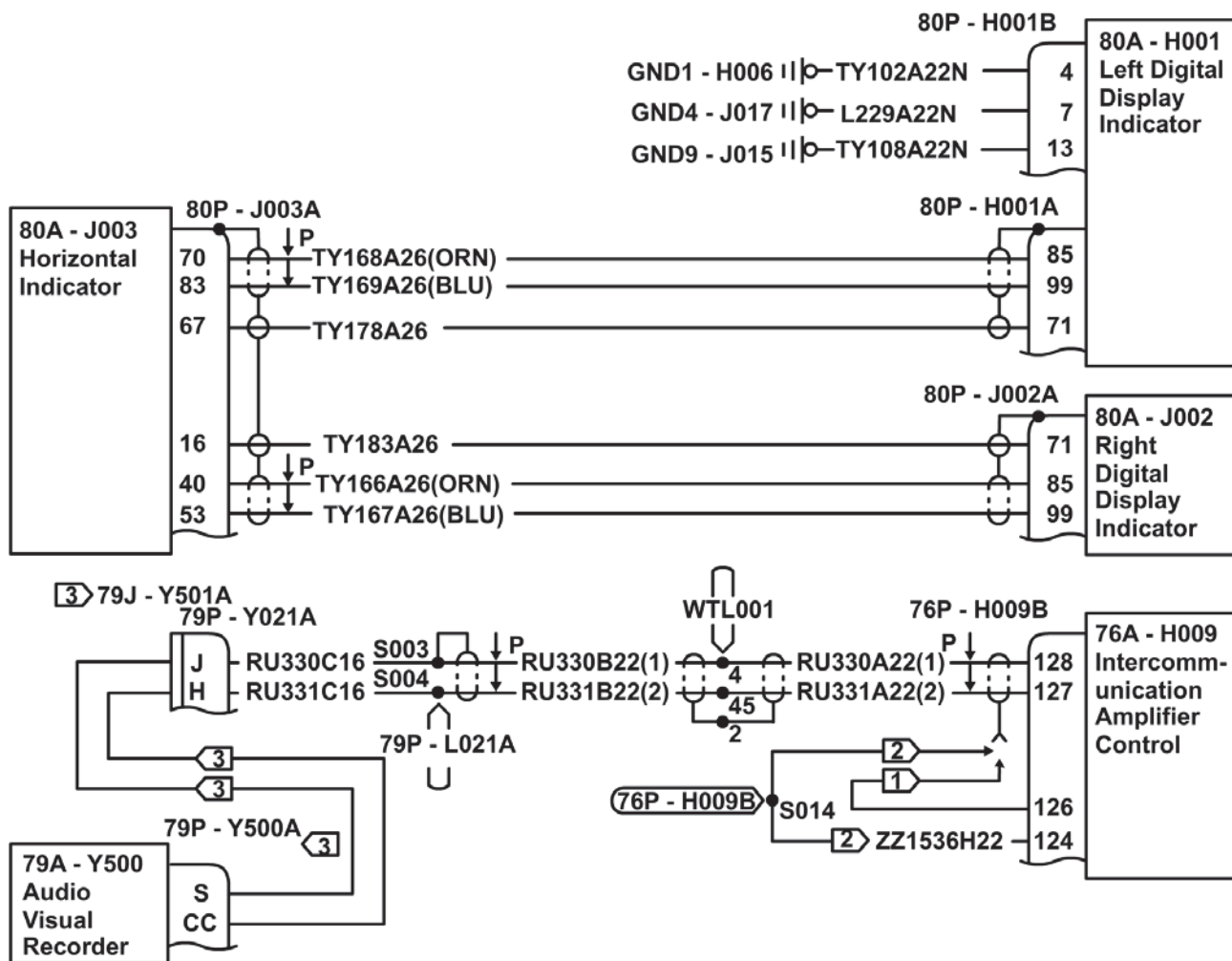

Figure 6-17 — Aircraft wiring diagram.

Each indicated part is identified by a reference designation number to help identify the circuit and to locate the illustrated parts breakdown (IPB) to determine value and other data. Wiring diagrams normally do not show the values of resistors, capacitors, or other components.

Some wiring diagrams have a wire identification code consisting of a three-part designation. The first part is a number representing the color code of the wire according to Military Specification MIL-W-76D. Many other wiring diagrams designate color coding by abbreviation of the actual colors as in *Figure 6-17*. The second part is the reference part designation number of the item to which the wire is connected, and the last part is the designation of the terminal to which connection is made.

Electromechanical Drawings

Electromechanical devices such as synchros, gyros, accelerometers, autotune systems, and analog computing elements are quite common in avionics systems. You need more than an electrical or electronic drawing to understand these systems adequately; therefore, we use a combination drawing called an electromechanical drawing. These drawings are usually simplified both electrically and mechanically, and show only those items essential to the operation. An example of one type of electromechanical drawing is shown in *Figure 6-18*.

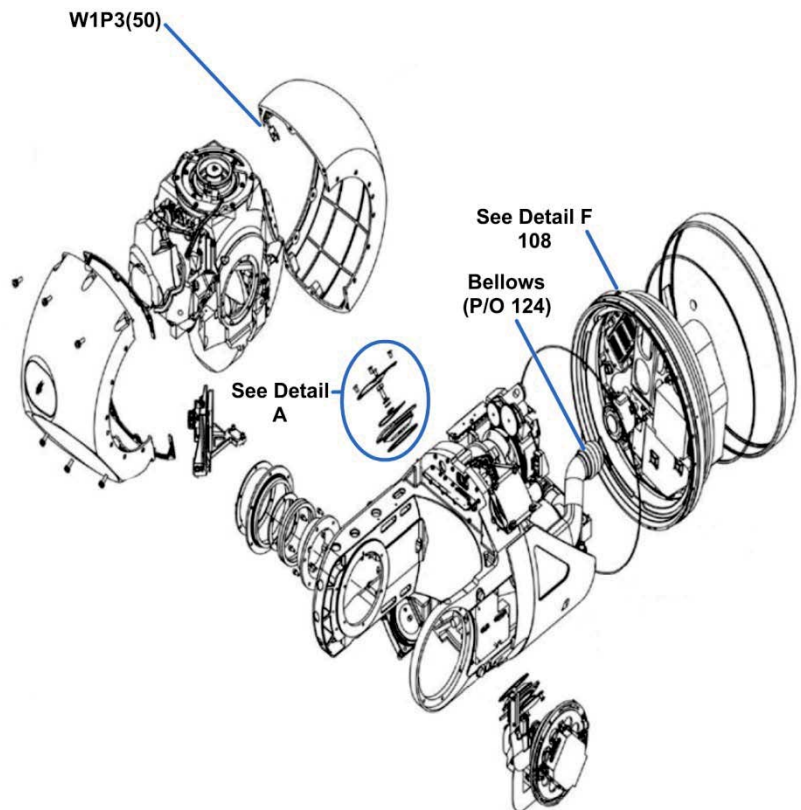

Figure 6-18 — Aircraft electro-optical sensor unit, electromechanical diagram.

Logic Diagrams

Logic diagrams are used in the operation and maintenance of digital computers. Graphic symbols from IEEE Standard 91A-1991 are used in these diagrams.

Computer Logic

Computers are used to make logical decisions about matters that can be decided logically. Some examples are when to perform an operation, what operation to perform, and which of several methods to follow. Computers never apply reason and think out an answer. They operate entirely on the principle of logic and use the true and false logic conditions of a logical statement to make a programmed decision. The rules for the equations and manipulations used by a computer often differ from the familiar rules and procedures of everyday mathematics.

People use many logical truths in everyday life without realizing it. Most of the simple logical patterns are distinguished by words such as AND, OR, NOT, IT, ELSE, and THEN. Once the verbal reasoning process has been completed and results put into statements, the basic laws of logic can be used to evaluate the process. Although simple logic operations can be performed by manipulating verbal statements, the structure of more complex relationships can be represented by symbols. Thus, the operations are expressed in what is known as symbolic logic.

The symbolic logic operations used in computers are based on the investigations of George Boole, and the resulting algebraic system is called Boolean algebra.

The objective of using Boolean algebra in digital computer study is to determine the truth value of the combination of two or more statements. Since Boolean algebra is based upon elements having two possible stable states, it is quite useful in representing switching circuits. A switching circuit can be in only one of two possible stable states at any given time; open or closed. These two states may be represented as 0 and 1 respectively. As the binary number system consists of only the symbols 0 and 1, we can see these symbols with Boolean algebra.

In familiar mathematics, there are four basic operations—addition, subtraction, multiplication, and division. Boolean algebra uses three basic operations—AND, OR, and NOT. If these words do not sound mathematical, it is only because logic began with words, and not until much later was it translated into mathematical terms. The basic operations are represented in logical equations by the symbols similar to the examples in *Table 6-7*.

The addition symbol (+) identifies the OR operation. The multiplication symbol or dot (•) identifies the AND operation, and parentheses and other multiplication signs may also be used.

Table 6-7 — Logic Symbols

OPERATION	MEANING
$A \bullet B$	A and B
$A + B$	A or B
\bar{A}	A Not or Not A
$(A + B) (C)$	A or B, and C
$AB + B$	A and B, or C
$\bar{A} \bullet B$	Not A, and B

Logic Operations

Three basic logic operations (AND, OR, and NOT) and four of the simpler combinations of the three (NOR, NAND, INHIBIT, and EXCLUSIVE OR) are shown in *Figure 6-19*. For each operation, the figure also shows a representative switching circuit, a truth table, and a block diagram. In some instances, it shows more than one variation to illustrate some specific point in the discussion of a particular operation. In all cases, a 1 at the input means the presence of a signal corresponding to switch closed, and a 0 represents the absence of a signal, or switch open. In all outputs, a 1 represents a signal across the load, a 0 means no signal.

For the AND operation, every input line must have a signal present to produce an output. For the OR operation, an output is produced whenever a signal is present at any input. To produce a no-output condition, every input must be in a no-signal state.

In the NOT operation, an input signal produces no output, while a no-signal input state produces an output signal. Notice the block diagrams representing the NOT circuit in *Figure 6-19*. The triangle is the symbol for an amplifier, and the small circle is the symbol for the NOT function. The circle is used to indicate the low-level side of the inversion circuit.

The NOR operation is simply a combination of an OR operation and a NOT operation. In the truth table, the OR operation output is indicated between the input and output columns. The switching circuit and the block diagram also indicate the OR operation.

The NAND operation is a combined operation, comprising an AND and a NOT operation.

The INHIBIT operation is also a combination AND and NOT operation, but the NOT operation is placed in one of the input legs. In the example shown, the inversion occurs in the B input leg; but in actual use, it could occur in any leg of the AND gate.

The EXCLUSIVE OR operation differs from the OR operation in the case where a signal is present at every input terminal. In the OR, an output is produced; in the EXCLUSIVE OR, no output is produced. In the switching circuit shown, both switches cannot be closed at the same time; but in actual computer circuitry, this action may not be the case. The accompanying truth tables and block diagrams show two possible circuit configurations. In each case the same final results are obtained, but by different methods.











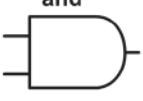
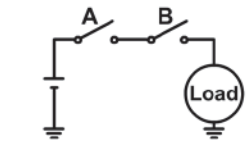

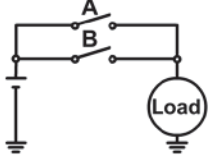
Function	Switching Circuit	Truth Table	Block Diagram																																																		
and 		<table border="1"> <thead> <tr> <th>A</th> <th>B</th> <th>AB</th> </tr> </thead> <tbody> <tr><td>0</td><td>0</td><td>0</td></tr> <tr><td>0</td><td>1</td><td>0</td></tr> <tr><td>1</td><td>0</td><td>0</td></tr> <tr><td>1</td><td>1</td><td>1</td></tr> </tbody> </table>	A	B	AB	0	0	0	0	1	0	1	0	0	1	1	1																																				
A	B	AB																																																			
0	0	0																																																			
0	1	0																																																			
1	0	0																																																			
1	1	1																																																			
or 		<table border="1"> <thead> <tr> <th>A</th> <th>B</th> <th>A+B</th> </tr> </thead> <tbody> <tr><td>0</td><td>0</td><td>0</td></tr> <tr><td>1</td><td>1</td><td>1</td></tr> <tr><td>1</td><td>0</td><td>1</td></tr> <tr><td>0</td><td>1</td><td>1</td></tr> </tbody> </table>	A	B	A+B	0	0	0	1	1	1	1	0	1	0	1	1																																				
A	B	A+B																																																			
0	0	0																																																			
1	1	1																																																			
1	0	1																																																			
0	1	1																																																			
Not 		<table border="1"> <thead> <tr> <th>A</th> <th>\bar{A}</th> </tr> </thead> <tbody> <tr><td>1</td><td>0</td></tr> <tr><td>0</td><td>1</td></tr> </tbody> </table>	A	\bar{A}	1	0	0	1	 																																												
A	\bar{A}																																																				
1	0																																																				
0	1																																																				
Nor 		<table border="1"> <thead> <tr> <th>A</th> <th>B</th> <th>A+B</th> <th>$\overline{A+B}$</th> </tr> </thead> <tbody> <tr><td>0</td><td>0</td><td>0</td><td>1</td></tr> <tr><td>0</td><td>1</td><td>1</td><td>0</td></tr> <tr><td>1</td><td>0</td><td>1</td><td>0</td></tr> <tr><td>1</td><td>1</td><td>1</td><td>0</td></tr> </tbody> </table>	A	B	A+B	$\overline{A+B}$	0	0	0	1	0	1	1	0	1	0	1	0	1	1	1	0																															
A	B	A+B	$\overline{A+B}$																																																		
0	0	0	1																																																		
0	1	1	0																																																		
1	0	1	0																																																		
1	1	1	0																																																		
Nand 		<table border="1"> <thead> <tr> <th>A</th> <th>B</th> <th>AB</th> <th>\overline{AB}</th> </tr> </thead> <tbody> <tr><td>0</td><td>0</td><td>0</td><td>1</td></tr> <tr><td>0</td><td>1</td><td>0</td><td>1</td></tr> <tr><td>1</td><td>0</td><td>0</td><td>1</td></tr> <tr><td>1</td><td>1</td><td>1</td><td>0</td></tr> </tbody> </table>	A	B	AB	\overline{AB}	0	0	0	1	0	1	0	1	1	0	0	1	1	1	1	0																															
A	B	AB	\overline{AB}																																																		
0	0	0	1																																																		
0	1	0	1																																																		
1	0	0	1																																																		
1	1	1	0																																																		
Inhibit 		<table border="1"> <thead> <tr> <th>A</th> <th>B</th> <th>$A\bar{B}$</th> </tr> </thead> <tbody> <tr><td>0</td><td>0</td><td>0</td></tr> <tr><td>0</td><td>1</td><td>0</td></tr> <tr><td>1</td><td>0</td><td>1</td></tr> <tr><td>1</td><td>1</td><td>0</td></tr> </tbody> </table>	A	B	$A\bar{B}$	0	0	0	0	1	0	1	0	1	1	1	0																																				
A	B	$A\bar{B}$																																																			
0	0	0																																																			
0	1	0																																																			
1	0	1																																																			
1	1	0																																																			
Exclusive or 		<table border="1"> <thead> <tr> <th>A</th> <th>B</th> <th>A+B</th> <th>AB</th> <th>$(A+B)(\bar{AB})$</th> </tr> </thead> <tbody> <tr><td>0</td><td>0</td><td>0</td><td>0</td><td>0</td></tr> <tr><td>0</td><td>1</td><td>1</td><td>0</td><td>1</td></tr> <tr><td>1</td><td>0</td><td>1</td><td>0</td><td>1</td></tr> <tr><td>1</td><td>1</td><td>1</td><td>1</td><td>0</td></tr> </tbody> </table> <table border="1"> <thead> <tr> <th>A</th> <th>B</th> <th>$A\bar{B}$</th> <th>$\bar{A}B$</th> <th>$A\bar{B} + \bar{A}B$</th> </tr> </thead> <tbody> <tr><td>0</td><td>0</td><td>0</td><td>0</td><td>0</td></tr> <tr><td>0</td><td>1</td><td>0</td><td>1</td><td>1</td></tr> <tr><td>1</td><td>0</td><td>1</td><td>0</td><td>1</td></tr> <tr><td>1</td><td>1</td><td>0</td><td>0</td><td>0</td></tr> </tbody> </table>	A	B	A+B	AB	$(A+B)(\bar{AB})$	0	0	0	0	0	0	1	1	0	1	1	0	1	0	1	1	1	1	1	0	A	B	$A\bar{B}$	$\bar{A}B$	$A\bar{B} + \bar{A}B$	0	0	0	0	0	0	1	0	1	1	1	0	1	0	1	1	1	0	0	0	 
A	B	A+B	AB	$(A+B)(\bar{AB})$																																																	
0	0	0	0	0																																																	
0	1	1	0	1																																																	
1	0	1	0	1																																																	
1	1	1	1	0																																																	
A	B	$A\bar{B}$	$\bar{A}B$	$A\bar{B} + \bar{A}B$																																																	
0	0	0	0	0																																																	
0	1	0	1	1																																																	
1	0	1	0	1																																																	
1	1	0	0	0																																																	

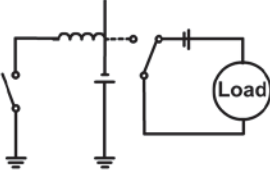
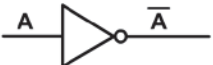
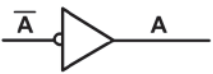
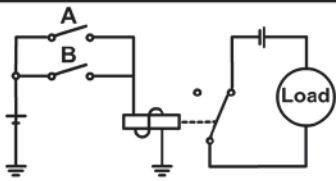
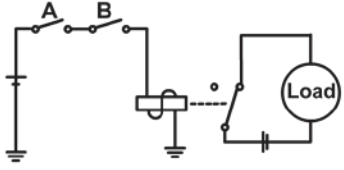
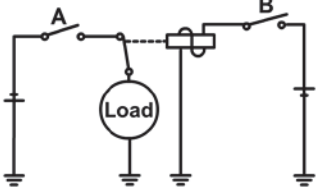
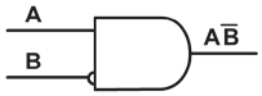
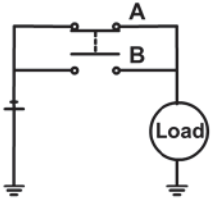
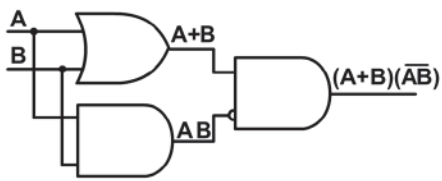
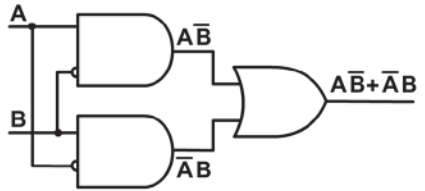
Figure 6-19 — Logic operations comparison chart.