

H. HUBBELL.
MULTIPLE ATTACHMENT PLUG.

APPLICATION FILED FEB. 26, 1903.

NO MODEL.

2 SHEETS—SHEET 1.

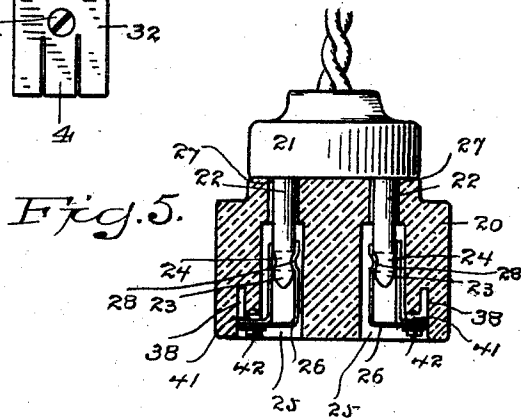
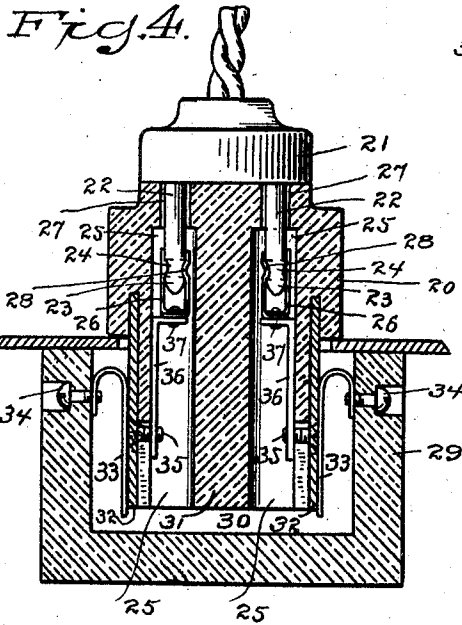
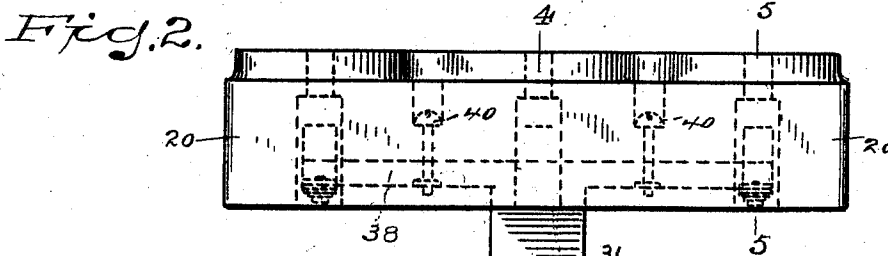
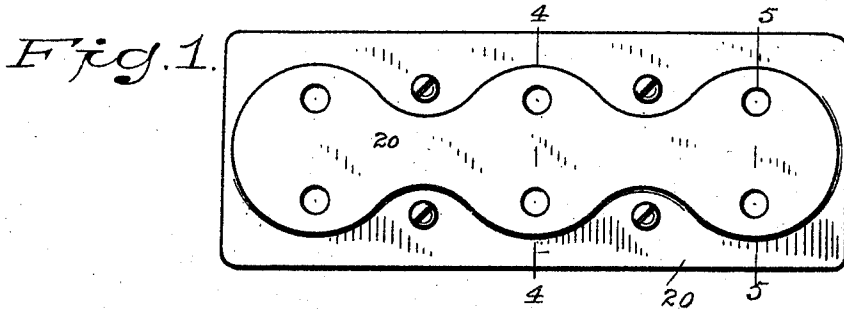
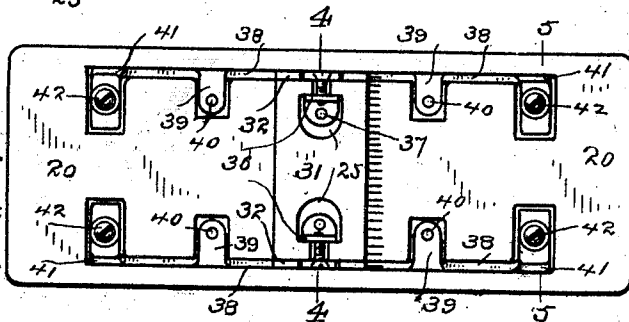

Fig. 3.



WITNESSES.

H. A. Lamb.
S. W. Archerton

INVENTOR.

Harvey Hubbell
By
A. M. Grosler
Att'y.

H. HUBBELL.
MULTIPLE ATTACHMENT PLUG.

APPLICATION FILED FEB. 26, 1903.

NO MODEL.

2 SHEETS—SHEET 2.

Fig. 6.

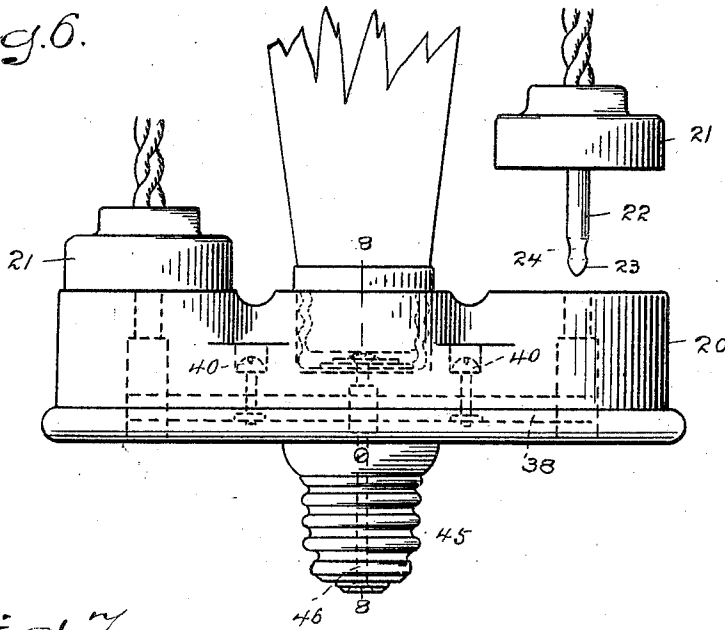

Fig. 7.

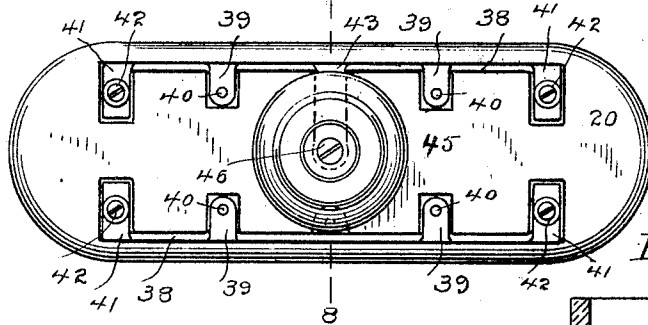

Fig. 9.

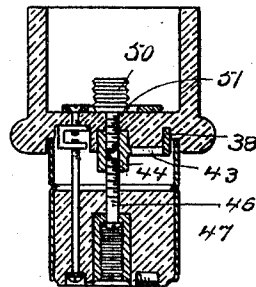
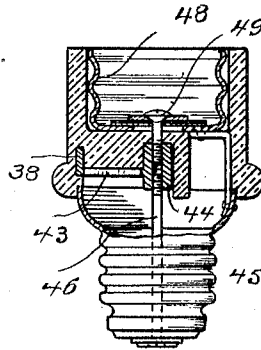

Fig. 8.



WITNESSES.

H. F. Lamb.
S. W. Atherton.

INVENTOR.

Harvey Hubbell
By A. Wilton
Atty.

UNITED STATES PATENT OFFICE.

HARVEY HUBBELL, OF BRIDGEPORT, CONNECTICUT.

MULTIPLE ATTACHMENT-PLUG.

SPECIFICATION forming part of Letters Patent No. 776,326, dated November 29, 1904.

Application filed February 26, 1903. Serial No. 145,211. (No model.)

To all whom it may concern:

Be it known that I, HARVEY HUBBELL, a citizen of the United States, residing at Bridgeport, county of Fairfield, State of Connecticut, have invented a new and useful Multiple Attachment-Plug, of which the following is a specification.

My invention has for its object to provide a multiple attachment-plug which shall comprise a body adapted to engage floor, wall, or ceiling receptacles or other fixtures and a plurality of separable caps which shall be adapted to engage the body, so that a plurality of lights, groups of lights, fans, motors, heating, soldering, surgical, or other appliances may be placed in the circuit simultaneously or independently.

A further object of the invention is to provide an improved attachment-plug which will enable users of electric current to effect a plurality of connections leading from different appliances simultaneously or to make changes in appliances without affecting other appliances in an instant's time without detachment of wires and without the use of any tools whatever.

It is a further object of the invention to provide a multiple attachment-plug of the character described which shall be so constructed as to reduce cost to the minimum and in use to prevent the possibility of arcing or sparking, whereby it is made perfectly safe and convenient for persons having no electrical knowledge or skill in the use of tools to place one or more lights or groups of lights, motors, fans, or other appliances simultaneously or independently in an electric circuit.

With these and other objects in view I have devised the simple and novel multiple attachment-plug, of which the following description, in connection with the accompanying drawings, is a specification, reference characters being used to designate the several parts.

Figure 1 is a plan view of one of my novel multiple attachment-plugs adapted for three simultaneous connections; Fig. 2, a side elevation of the body; Fig. 3, an inverted plan view of the body; Fig. 4, a section on the line 4 4 in Figs. 1, 2, and 3, showing the body in

place in a receptacle and also showing a cap connected therewith; Fig. 5, a section on the line 5 5 in Figs. 1, 2, and 3 and also showing a cap connected to the body; Fig. 6, an elevation illustrating a variant form of the invention which is adapted for use in connection with an Edison socket instead of a receptacle, the body being adapted to receive an Edison lamp and two caps, one cap being shown connected, the other detached; Fig. 7, an inverted plan view corresponding with Fig. 6; Fig. 8, a section on the line 8 8 in Figs. 6 and 7, the lamp being removed; and Fig. 9 is a view corresponding with Fig. 8, illustrating the slight changes in the details of construction required to adapt the body for attachment to a Thomson-Houston socket and to receive a Thomson-Houston lamp.

My novel attachment-plug comprises, essentially, a body 20 and a plurality of interchangeable caps 21, which are adapted to be attached to any body simultaneously or independently irrespective of whether the body is adapted for use in connection with a receptacle of any ordinary type—as, for instance, the type illustrated in Fig. 4—or with an Edison, Thomson-Houston, or other form of socket.

The interchangeable caps may be made of porcelain, fiber, or other suitable insulating material and are each provided with a pair of contact-posts 22, extending outward therefrom. These posts are provided with heads 23, below which are reduced necks 24, which are adapted to engage contact-springs in the body, as will presently be fully explained.

The body consists of a block of porcelain, fiber, or other insulating material having pairs of independent recesses 25, separated from each other by a portion of the body of insulating material and adapted to receive locking contact-springs 26. Leading into said recesses are independent guide-holes 27, which direct the contact-posts and steady them as they are pushed to place, thereby insuring immediate and certain engagement of the contact-posts with the locking contact-springs as soon as a cap is pushed to place. The locking contact-springs 26 comprise one or more strips of metal bent to substantially U shape, one or

both springs being more or less concaved, if preferred, and one of the springs, or both, if preferred, being provided with inwardly-curved engaging portions 28, which engage the necks of the contact-posts and detachably secure the caps to the body and place the lamp, group of lamps, fan, motor, or other appliance to which the cap is connected in the circuit.

In Fig. 1 I have illustrated a form of my novel multiple attachment-plug adapted for use in connection with a floor, wall, or ceiling receptacle. 29 denotes the receptacle, which is ordinarily adapted for attachment flush or approximately flush with the surface of a floor, wall, or ceiling. It is provided with a recess 30, adapted to receive a hub or projection 31 on the body. This hub is provided with contact-plates 32, which are adapted to engage contact-springs 33 in the recess which retain the body in place by frictional contact or otherwise. The receptacle is ordinarily made of porcelain, fiber, or other suitable insulating material, and the springs are attached thereto by screws 34, which also serve as binding-screws for electrical connections. (Not shown.) It will be obvious from Fig. 4 that the central recesses 25 in the body extend down through hub or projection 31. Contact-plates 32 are attached to the hub by means of screws 35, which pass through the walls of recesses 25 and engage brackets 36 in said recesses—that is, the central recesses only—thus securing both the contact-plates and the brackets to the hub. The locking contact-springs 26 in the central recesses comprise a single strip of metal bent to substantially U shape and attached to the brackets, as at 37. Contact-plates 32 have formed integral therewith contact-strips 38, provided with ears 39, which are attached to the body by means of screws 40 and with ears 41, to which locking contact-springs 26 are attached. The locking contact-springs 26 other than the central locking contact-springs, which are shown as made from a single strip of metal, are shown as made of two strips of metal and as attached to ears 41 by screws 42.

The forms illustrated in Figs. 6 to 9, inclusive, differ from the forms illustrated in Figs. 1 to 5, inclusive, only in details of construction, which are not of the essence of the invention. In these forms hub or projection 31 is dispensed with, and one of the contact-strips 38 instead of being attached to or formed integral with a contact-plate 32 is provided with an inwardly-extending arm 43, which carries a central hub 44. This hub receives the current from an Edison or Thomson-Houston socket in the same manner that contact-plates 32 receive the current from a receptacle—as, for example, in Fig. 4.

The forms illustrated in Figs. 6 to 9, inclusive, are shown as adapted for use where it is desired to have a fixed Edison or Thomson-

Houston lamp always ready for use, the fixed lamp being substituted for a pair of central locking contact-springs adapted to operate in connection with the locking-posts on a cap. 45, in Fig. 8, denotes a base which is adapted for attachment to an Edison socket and is attached to hub 44 by a screw 46. 47, in Fig. 9, denotes a base which is adapted for attachment to a Thomson-Houston socket and is likewise attached to the central hub by a screw 46. 48, in Fig. 8, denotes the usual shell, having a female thread which receives the male thread of an Edison lamp. This shell is attached to central hub 44 by a screw 49. 50, in Fig. 9, denotes the usual male screw, which is engaged by the female thread of a Thomson-Houston lamp. This screw is provided with a reduced shank 51, which is threaded to engage the central hub 44.

In use in attaching a hanging or drop light, fan, motor, or other appliance whose electrical connections are of course provided with a cap having contact-posts the operator simply passes the contact-posts of the cap through the guide-holes in the body and engages the neck of the posts with the locking contact-springs. This engagement of the contact-posts with the locking contact-springs retains the cap securely in place under all the ordinary conditions of use and insures perfect electrical connection. To detach a cap from the body and break the connection, it is simply required to pull the cap away from the body with sufficient force to overcome the resistance of the locking contact-springs.

Having thus described my invention, I claim—

1. A multiple attachment-plug comprising an insulating-body having a plurality of pairs of independent recesses, locking contact-springs in said recesses, means for electrically connecting the body to an electrical fixture and caps having independent contact-posts adapted to engage the locking contact-springs, whereby a plurality of electric appliances may be placed in the circuit simultaneously or independently, the walls of said recesses closely surrounding said contact-springs and extending beyond the ends thereof, whereby a connection can be established only upon the passage of the contact-posts through the guide-holes and into the inner spaces constituting said recesses.

2. A multiple attachment-plug comprising an insulating-body having a plurality of pairs of independent recesses, locking contact-springs in said recesses, independent guide-holes leading into said recesses, means for making electrical connection of the body to an electrical fixture and caps having independent contact-posts adapted to pass through the guide-holes and engage the locking contact-springs, the walls of said recesses closely surrounding said contact-springs and extending

beyond the ends thereof, whereby a connection can be established only upon the passage of the contact-posts through the guide-holes and into the inner spaces constituting said recesses.

5 3. A multiple attachment-plug comprising an insulating-body having a plurality of pairs of independent recesses, locking contact-springs in said recesses and closely surrounded
10 thereby, a contact-strip to which contact-springs are attached, means for connecting the contact-strip electrically with an electrical fixture and caps having independent contact-
15 posts adapted to engage the locking contact-springs, the insulating-body being formed with guide-holes having walls free from electrical connections, whereby a connection can be established only upon the passage of the
20 contact-posts through the guide-holes and into the inner spaces constituting said recesses.

4. A multiple attachment-plug comprising an insulating-body having a plurality of pairs of independent recesses, locking contact-

springs in said recesses and closely surrounded
25 thereby, a contact-strip to which contact-springs are attached, means for connecting the contact-strip electrically with an electrical fixture, means for connecting an electric lamp
30 directly to the body and caps having independent contact-posts adapted to engage locking contact-springs, whereby other lamps or appliances may be connected to the body simultaneously or independently, the insulating-
35 body being formed with guide-holes having walls free from electrical connections, whereby a connection can be established only upon the passage of the contact-posts through the guide-holes and into the inner spaces constituting said recesses.

In testimony whereof I affix my signature in presence of two witnesses. 40

HARVEY HUBBELL.

Witnesses:

A. M. WOOSTER,
S. W. ATHERTON.