

H. HUBBELL.
SEPARABLE ATTACHMENT PLUG.
APPLICATION FILED MAY 27, 1904.

NO MODEL.

2 SHEETS—SHEET 1.

Fig. 1.

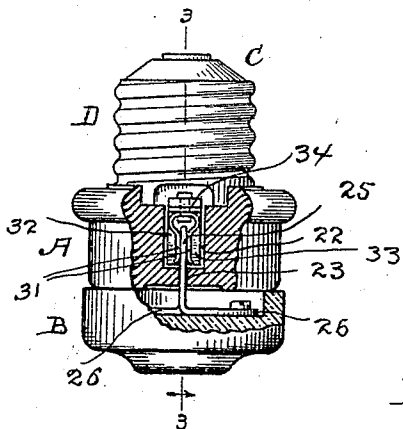

Fig. 3.

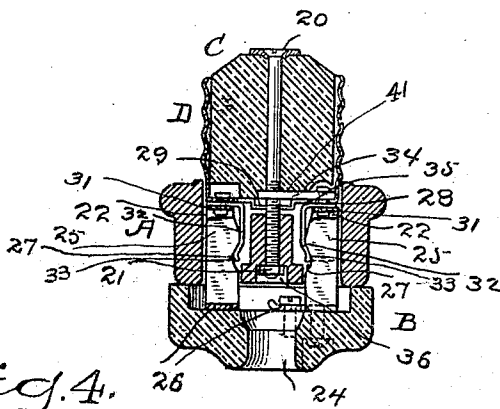

Fig. 4.

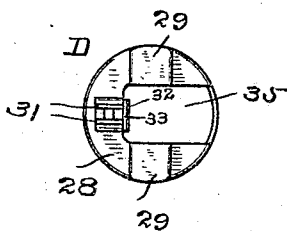

Fig. 2.

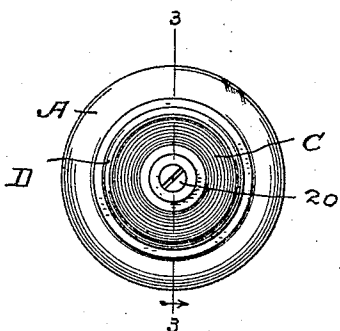

Fig. 5.

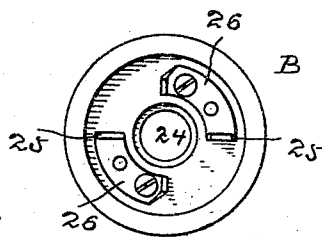
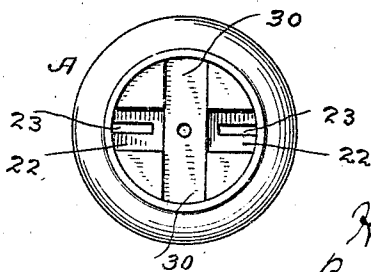

Fig. 6.



WITNESSES.

H. A. Lamb
J. W. Atherton.

INVENTOR.

Harvey Hubbell
By A. M. Wooster
Att'y.

H. HUBBELL.
SEPARABLE ATTACHMENT PLUG.

APPLICATION FILED MAY 27, 1904.

NO MODEL.

2 SHEETS—SHEET 2.

Fig. 7.

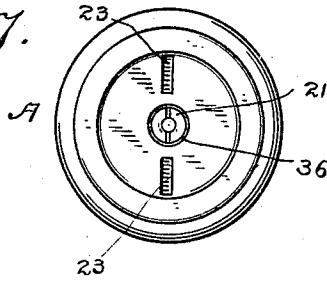

Fig. 8.

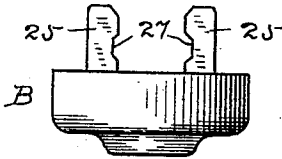

Fig. 9.

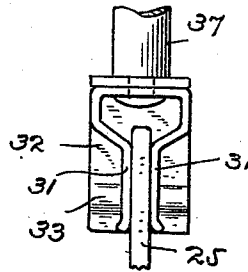

Fig. 10.

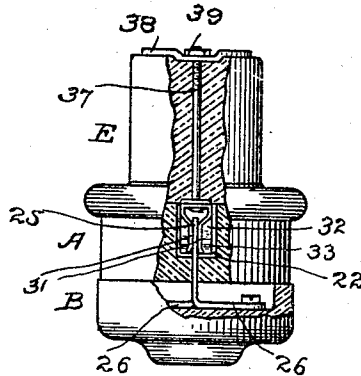

Fig. 12.

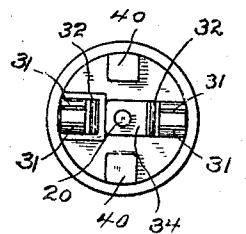
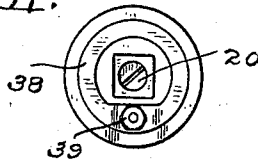

Fig. 11.



WITNESSES.

H. A. Lamb.
S. W. Atherton.

INVENTOR.

Harvey Hubbell
By A. M. Wooster
Atty.

UNITED STATES PATENT OFFICE.

HARVEY HUBBELL, OF BRIDGEPORT, CONNECTICUT.

SEPARABLE ATTACHMENT-PLUG.

SPECIFICATION forming part of Letters Patent No. 774,251, dated November 8, 1904.

Application filed May 27, 1904. Serial No. 210,066. (No model.)

To all whom it may concern:

Be it known that I, HARVEY HUBBELL, a citizen of the United States, residing at Bridgeport, county of Fairfield, State of Connecticut, have invented a new and useful Separable Attachment-Plug, of which the following is a specification.

My invention has for its general object to produce a practical, durable, and inexpensive direct-acting separable attachment-plug that will avoid the objections raised by the underwriters to attachment-plugs of this type now upon the market and shall have for its special objects to produce a direct-acting attachment-plug in which ample current-carrying capacity shall be provided independently of locking-springs, which may or may not be used, and in which the possibility of arcing or sparking in making the contact shall be wholly done away with.

With these and other objects in view I have devised a novel attachment-plug in which a base is provided with insulating-chambers to receive contact-plates and locking-springs, if used, and with contracted insulating-passages leading to said chambers, in which the end block is made independent of the base and is secured thereto, covering the chambers, and in which an insulating-cap is provided with knife-blade contacts which engage the contact-plates after they have been passed through the contracted insulating-passages. It should be noted that the object in making the base and end block independent is to permit the formation of the insulating-chambers in the base, which receive the contact-plates and the locking-springs, if used, said chambers being covered by the end block, and, furthermore, that by providing contact-plates of ample current-carrying capacity in the chambers independent of the locking-springs it becomes immaterial, so far as the current-carrying is concerned, whether or not locking-springs are used. My present construction therefore enables me to avoid certain of the most serious objections raised by the underwriters to attachment-plugs heretofore placed upon the market.

In the accompanying drawings, forming a part of this specification, Figures 1 to 4, in-

clusive, are views illustrating the application of the principle of the invention to an Edison socket, Fig. 1 being an elevation, partly broken away; Fig. 2, a plan view corresponding therewith; Fig. 3, a section on the line 3 3 in Fig. 1; Fig. 4, an inverted plan view of the screw-shell detached, showing one pair of contact-plates and a locking-spring attached thereto. Figs. 5 to 8, inclusive, are views common to the Edison and Thomson-Houston forms, Fig. 5 being a plan view of the cap detached; Fig. 6, a plan view of the base detached; Fig. 7, an inverted plan view of the base detached; Fig. 8, an elevation of the cap detached. Figs. 9 to 12, inclusive, are views illustrating the application of the principle of the invention to a Thomson-Houston socket, Fig. 9 being a detail view, on a greatly enlarged scale, illustrating the engagement of one of the knife-blade contacts with the corresponding contact-plates and with a locking-spring; Fig. 10, an elevation, partly broken away; Fig. 11, a plan view of the end block detached, and Fig. 12 is an inverted plan view of the end block with both pairs of contact-plates and also locking-springs in place thereon.

The bases and caps of the two forms are exactly alike and are interchangeable. The end blocks, however, in the two forms differ slightly in details of construction.

A denotes the base; B, the cap; C, the end block of the Edison form; D, the screw-shell, and E the end block of the Thomson-Houston form. The base is a solid piece of porcelain or other insulating material, and the end block in both forms is likewise a single piece of porcelain or other insulating material and is attached thereto by a single screw, (indicated by 20,) which passes through central holes in the block and base, the parts being locked together by a nut 21, shown as lying in a socket 36 in the under side of the base. The base is provided with chambers 22, each of which receives a pair of contact-plates and may or may not receive a locking-spring, presently to be described.

23 denotes contracted passages leading into the chambers, which are made just large enough to receive the knife-blade contacts

presently to be described. The cap, which is likewise a single piece of porcelain, is provided with the usual central opening 24, through which the conductors (not shown) pass.

25 denotes the knife-blade contacts, which are shown as attached to the cap by means of integral plates 26. If locking-springs are to be used, the edge of each knife-blade contact is provided with a recess 27, adapted to be engaged by a locking-spring, presently to be described.

In the Edison form (see Figs. 1 to 4, inclusive) the end block C is inclosed in the metallic screw-shell D. This screw-shell has a bottom 28, upon which the end block rests, the bottom of the block being preferably provided with bosses which engage depressions 29, formed in the bottom of the screw-shell. When assembled, these depressions engage recesses 30 in the base and serve to anchor the parts firmly in place and prevent their movement relatively to each other. 31 denotes the contact-plates, which are formed to closely engage the opposite sides of the knife-blade contacts. Under certain conditions of use the frictional engagement of the contact-plates with the knife-blade contacts is sufficient to retain the cap in place. Where, however, the conditions of use are such that there is an appreciable strain, tending to separate the cap from the base, I provide locking-springs 32, which are each provided with a projection 33, adapted to engage the recess 27 in the corresponding knife-blade contact, as is clearly shown in Fig. 3. In this form one pair of contact-plates and the corresponding locking-spring are riveted, soldered, or otherwise rigidly secured to the bottom of the screw-shell, as clearly shown in Figs. 3 and 4. The other pair of contact-plates and corresponding locking-spring are riveted, soldered, or otherwise rigidly secured to a plate 34, which lies in an opening 35 in the screw-shell (see Fig. 4 in connection with Fig. 3) and is securely held in place by screw 20, which passes through it. In assembling, the insulating-block C is dropped into the screw-shell. Screw 20 is passed through the insulating-block and turned through plate 34 until said plate is drawn tightly into a recess 41 in the under side of the block. (See Fig. 3.) Then the insulating-block and screw-shell are placed in position on the base, the screw passing through the base, the contact-plates and locking-springs lying in the chambers, and depressions 29 on the screw-shell engaging recesses 30 in the base, and then the parts are locked together by nut 21, shown as lying in socket 36 in the base. To make an electrical connection, the operator passes the knife-blade contacts through contracted insulating-passages 23 and presses them into engagement with the contact-plates in the chambers, the locking-springs, if used, engaging the recesses in the

edges of the knife-blade contacts and retaining the parts in connection, as clearly shown in Figs. 1, 3, and 9. It will be seen that this construction avoids the possibility of arcing and the danger of contact with electrical connections, as there are no exposed connections, the current-carrying connections—*i. e.*, the contact-plates—being housed in separate insulating-chambers in the base and it being impossible to make an electrical connection until the knife-blade contacts of the cap have been passed through the contracted insulating-passages 23, which lead into the chambers. These passages guide and control the knife-blade contacts while they are being pressed into the connecting position, the contact being made by a forward movement of the cap and without the slightest twisting of the electrical conductors. It should be noted that the passages are made just large enough and just the right shape to receive the knife-blade contacts and guide them into the chambers where the connection is made with the contact-plates.

The Thomson-Houston form differs from the Edison form only in details of construction. In this form, as no screw-shell is used to which one pair of contact-plates and the corresponding locking-spring can be secured, I secure one pair of contact-plates and the corresponding locking-spring, if used, to the end block by means of a bolt or screw 37, which passes through the block and secures one pair of contact-plates and the corresponding locking-spring to the insulating-block and also retains the contact-ring 38 in place upon the top of the block. In the present instance the upper end of the bolt is threaded and is engaged by a nut 39, lying in a recess in the contact-ring. The other pair of contact-plates and corresponding locking-spring, if used, are secured to a plate 34, which is held in place by screw 20, as in the Edison form. (See Fig. 12.) The insulating-block and the base are retained against movement relatively to each other by means of lugs 40 on the under side of the end block, which engage the recesses 30 in the base, substantially as in the other form, the only difference being that in the Edison form the lugs engage depressions in the bottom of the screw-shell, and these depressions engage the recesses 30 in the base.

Having thus described my invention, I claim—

1. A separable attachment-plug comprising a base provided with insulating-chambers and contracted insulating-passages leading into said chambers, contact-plates in said chambers, an end block secured to the base and covering the chambers, and a cap provided with contacts adapted to pass through the contracted insulating-passages and engage the contact-plates in the insulating-chambers.

2. A separable attachment-plug comprising a base provided with insulating-chambers and insulating-passages leading into said cham-

bers, contact-plates and locking-springs in said chambers, an end block secured to the base and covering the chambers, and a cap provided with contacts adapted to pass through the insulating-passages and engage the contact-plates and locking-springs in the insulating-chambers.

3. A separable attachment-plug comprising a base provided with insulating-chambers and insulating-passages leading into said chambers, contact-plates and locking-springs in said chambers and a cap provided with knife-blade contacts adapted to pass through the insulating-passages and engage the contact-plates and having recesses in their edges which are engaged by the locking-springs to retain the knife-blade contacts and contact-plates in engagement.

4. A separable attachment-plug comprising a base provided with recesses 30, insulating-chambers and insulating-passages leading into said chambers, contact-plates in said chambers, an end block engaging the recesses in the base and secured to said base so as to cover the chambers and a cap provided with contacts adapted to pass through the insulating-passages and engage the contact-plates in the insulating-chambers.

5. A separable attachment-plug comprising a base provided with recesses 30, insulating-chambers and insulating-passages leading into said chambers, contact-plates and locking-springs in said chambers, an end block engaging the recesses in the base and secured to said base so as to cover the chambers and a cap provided with contacts adapted to pass through the insulating-passages and engage the contact-plates and locking-springs in the insulating-chambers.

6. A separable attachment-plug comprising a base provided with insulating-chambers and insulating-passages leading into said chambers, contact-plates in said chambers, an insulating end block which covers the recesses, a screw passing centrally through the end block and base by which they are secured together and a cap provided with contacts adapted to pass through the insulating-passages and engage the contact-plates in the insulating-chambers.

7. A separable attachment-plug comprising a base provided with insulating-chambers and insulating-passages leading into said chambers, contact-plates and lockings-prings in said chambers, an insulating end block which cov-

ers the recesses, a screw passing centrally through the end block and base by which they are secured together and a cap provided with contacts adapted to pass through the insulating-passages and engage the contact-plates and locking-springs in the insulating-chambers.

8. A separable attachment-plug comprising a base provided with insulating-chambers and insulating-passages leading into said chambers, contact-plates in said chambers, a screw-shell having a bottom lying in engagement with the base, an end block within the screw-shell, a screw passing centrally through the end block and base by which said parts and the screw-shell are secured together, and a cap provided with contacts adapted to pass through the insulating-passages and engage the contact-plates in the insulating-chambers.

9. A separable attachment-plug comprising a base provided with insulating-chambers and insulating-passages leading into said chambers, contact-plates and locking-springs in said chambers, a screw-shell having a bottom lying in engagement with the base, an end block within the screw-shell, a screw passing centrally through the end block and base by which said parts and the screw-shell are secured together, and a cap provided with contacts adapted to pass through the insulating-passages and engage the contact-plates and locking-springs in the insulating-chambers.

10. A separable attachment-plug comprising a base provided with insulating-chambers and insulating-passages leading into said chambers, a screw-shell having a bottom lying in engagement with the base and having a pair of contact-plates and a locking-spring secured thereto, an end block within the screw-shell, a plate 34 having another pair of contact-plates and a locking-spring secured thereto, a screw passing centrally through the end block and base and through the plate by which said end block, base, plate and screw-shell are secured together, the contact-plates and locking-springs lying in the insulating-chambers and a cap provided with contacts adapted to pass through the insulating-passages and engage the contact-plates and locking-springs in the insulating-chambers.

In testimony whereof I affix my signature in presence of two witnesses.

HARVEY HUBBELL.

Witnesses:

A. M. WOOSTER,
S. W. ATHERTON.