

April 13, 1948.

F. S. GREEN

2,439,511

LATCHING OR TRIPPING MECHANISM OF CIRCUIT BREAKERS

Filed April 10, 1944

2 Sheets-Sheet 1

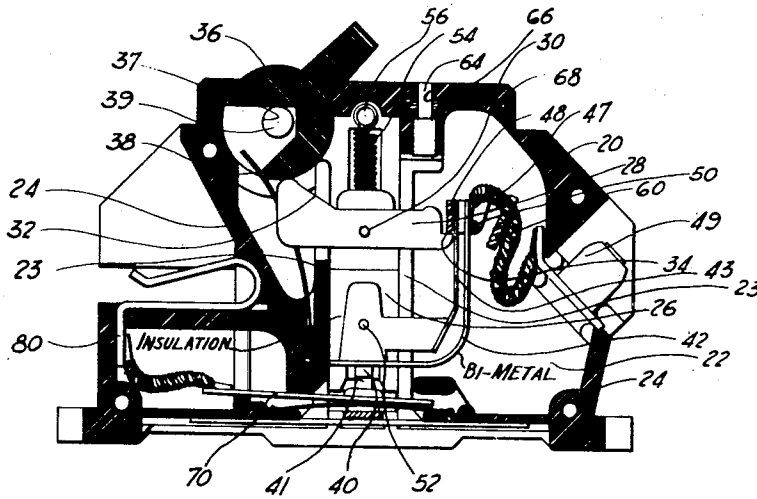

FIG. 1

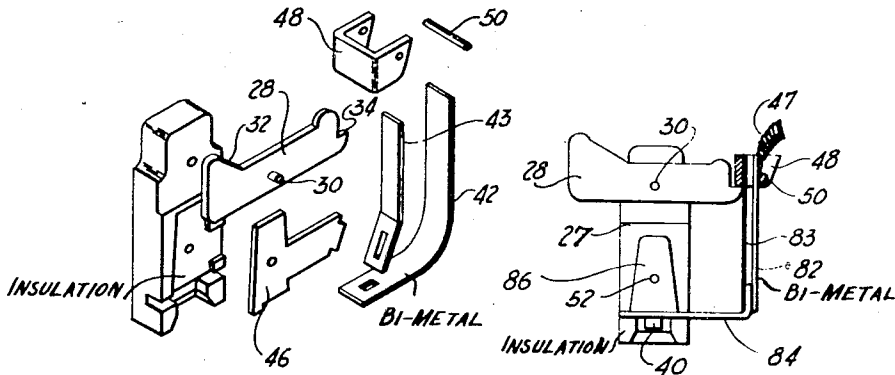

FIG. 2

FIG. 3

INVENTOR.  
FLOYD S. GREEN  
BY Don A. Tischeu ATTY.

April 13, 1948.

F. S. GREEN

2,439,511

LATCHING OR TRIPPING MECHANISM OF CIRCUIT BREAKERS

Filed April 10, 1944

2 Sheets-Sheet 2

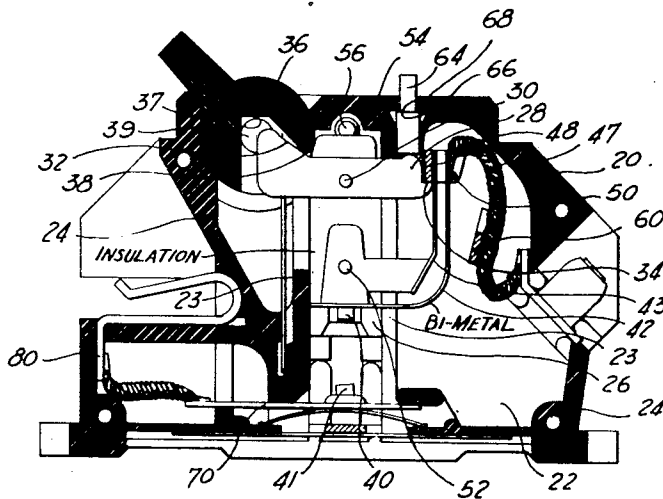

FIG. 4.

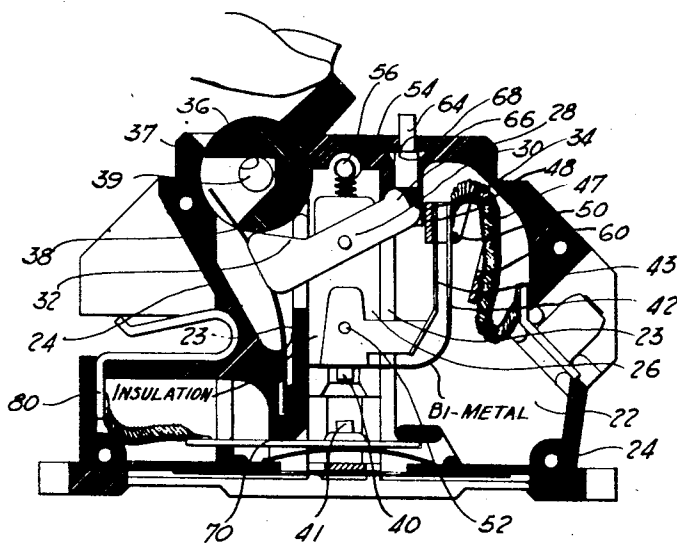

FIG. 5

INVENTOR.  
FLOYD S. GREEN  
BY *Doc. A. Fischer* ATTY

# UNITED STATES PATENT OFFICE

2,439,511

## LATCHING OR TRIPPING MECHANISM OF CIRCUIT BREAKERS

Floyd S. Green, St. Louis, Mo., assignor to Frank  
Adam Electric Company, St. Louis, Mo., a cor-  
poration of Missouri

Application April 10, 1944, Serial No. 530,390

3 Claims. (Cl. 200—88)

1

This invention relates to improvements in circuit interrupting devices. More particularly it relates to improvements in the latching or tripping mechanism of circuit breakers.

It is an object of this invention to provide an improved arrangement of thermal element and latch whereby a more satisfactory operation of the circuit breaker is achieved.

The improved arrangement of latch and thermal element may be combined with a magnetic trip device to insure improved operation.

In some circuit breakers it has been the practice to provide a latch on the thermal element. This invention relieves the thermostatic element of the latch by providing a separate and independent support for the latch. The thermal element may then operate independently of the latch to move the latch and cause the circuit breaker to trip. This feature has been found to considerably shorten the time taken for the breaker to open on the occurrence of a short circuit. On circuit breakers combining a magnetic trip with a thermal trip it has been found that this feature makes the magnetic trip more effective since less pressure is required to trip the circuit breaker than before.

Further objects and advantages of the invention will become apparent from the following detailed description and the accompanying drawings.

Several preferred forms of the invention are shown in the accompanying drawings and are hereinafter described, but it is understood that the drawings and accompanying description do not limit the invention to the forms there shown and here described, but that the invention will be defined by the appended claims.

In the accompanying drawings:

Fig. 1 is a longitudinal sectional view of a circuit breaker of the type shown and described in United States Patent No. 2,424,909, July 29, 1947, to F. B. Adam et al. A similar circuit breaker is also shown in United States Patent No. 2,328,767, Sept. 7, 1943, to F. B. Adam et al.

Fig. 2 is an exploded view of the contact carrier, thermal element and latch shown in Fig. 1.

Fig. 3 is a longitudinal sectional view of a contact carrier, thermal element and latch which may be substituted for that shown in Fig. 2 in the circuit breaker of Fig. 1.

Fig. 4 is a longitudinal sectional view of the circuit breaker shown in Fig. 1 in the tripped position.

Fig. 5 is a longitudinal sectional view of the circuit breaker shown in Fig. 1 in the manual "off" position.

2

Referring now to the drawings, 20 is a housing or enclosure which may be formed of molded plastic or other suitable material. The material is formed to provide walls 24 surrounding cavities 22 in which the operating parts are positioned. The contact carrier 26 is guided and maintained in position for sliding movement in the housing, by the inner walls 23. The housing may be formed of two substantially identical half sections. The contact carrier is provided with a transverse bar 28. The transverse bar may be pivotally supported for rotation about a pivot 30. A cam surface 32 is provided on one end of the transverse bar while on the other end a projection 34 may be provided. An operating handle 36, which may be formed of a molded insulating material, is provided with openings 37 which are journaled on pivot 39 formed on the housing. The contacts 40 and 41 are the make and break contacts of the device. The contact 40 is the movable contact and is carried by the contact carrier 36.

The contact 40 may be part of an assembly shown in detail in Fig. 2, in which the thermal element or bimetallic strip 42 is electrically connected and mechanically secured to the contact. 43 is a flexible support for latch part 48. Latch part 48 is formed in a U-shape of magnetic material and co-operates with the magnetic or soft iron armature 60 to provide the magnetic trip for the breaker. A mounting piece 46 is positioned between the two half sections of the contact carrier and maintained in position by a rivet 52 which passes therethrough. This mounting piece supports the support 43. The U-shaped magnetic member 48 may be secured to the support 43 by welding or by a rivet or other suitable means. A pin 50 which may be of insulating material is secured to the member 48 as shown.

An optional form of the device is shown in Fig. 3. In this form of the device the two half sections 27 of the contact carrier are similar to those denoted by numeral 26. The transverse bar 28 is the same as described in connection with Fig. 2. The bimetal 82 is straight in this modification as is the latch part support 83. The U-shaped latch part 48 is secured as before, to the latch part support, which in this case is 83. A support 84 for the bimetal and the flexible support 83 extends outwardly from the contact carrier and is secured to the member 86 in a manner similar to that used in securing the bimetal 42 to the member 46. The member 86 is similar to the member 46 except that the exten-

3

sion which extends out of the side of the contact carrier is not necessary. The members 82 and 83 may be secured to members 84 in any suitable manner, as by riveting or welding.

It can be seen that when the thermal element defects because of excess current passing there-through, it abuts against pin 50 thereby pulling latch 48 off of the transverse bar 28. The latch support 43 need be only strong enough to support and position properly the member 48 which serves as a latch in conjunction with the latch end 34 of the transverse bar. Since the thermal element must be selected with reference to its current carrying ability and time of deflection for a particular current it is usually stiffer than need be to support the member 48. This means that the trip action of the circuit breaker is unnecessarily hampered when the latch is supported by the thermal element. With the arrangement of this invention however, as just set forth, the movement of the latch is in no way restricted by the stiffness of the thermal element 42. At the same time the thermal element may operate the latch 48 easily.

The other parts and arrangement of the circuit breaker are substantially as shown and described in the United States patents previously mentioned. The contact carrier is biased in the open position by a spring 54 secured to the contact carrier at one end and to the housing at the other end by slipping it over a projection 56 on the housing.

A copper pigtail 47 electrically connects the thermal element with the terminal piece 49. 64 is an indicator which may be provided and is positioned in an opening 66 in the housing. A spring 68 maintains the indicator in a retracted position until it is struck by the transverse bar. The contact 41 may be secured to a contact strip 70. A copper pigtail connects the contact strip 70 with a terminal 80.

The handle 36 is used for manually opening and closing the circuit. This is accomplished by the follower portion 38 on the handle engaging the inclined portion 32 of the transverse bar and thus forcing the bar to the "on" position against the bias of the spring 54. When the handle is moved in the opposite direction the contacts are separated by the springs 54. This position is shown in Fig. 4 of the drawings.

The tripping of the circuit breaker may be brought about by either one of two actions, or by a combination of the two actions. Thus, if the bimetallic element 42 is heated by a high abnormal current for a short time, or by a lower abnormal current for a longer period of time, it will be distorted and will push against the pin 50 thus pulling the member 48 off of the projection 34 of the transverse bar. This allows the transverse bar to rotate and the contact carrier 26 will move to the open circuit position. This is shown in Fig. 5 of the drawings. Should a short circuit occur, the heavy rush of current through the bimetal and the pigtail will create a strong magnetic field which will magnetize the soft iron magnet piece 48 and the fixed member 60, causing them to be attracted to each other. This will cause the member 48 to be pulled off of the projection 34 which will allow the circuit breaker to open.

The magnetic trip action will operate the breaker faster in case of a short circuit than the thermal element alone, and hence is desirable in operating the circuit breaker on a short circuit.

The magnetic action is especially fast in de-

4

VICES equipped with this invention for the thermal element exerts no restraining force on the movement of the member 48 as is the case when the member 48 or its equivalent is supported on the thermal element.

Since the member 48 is not carried by the relatively stiff thermal element or bimetallic strip it can slide easily across the projection 34. This insures that the circuit breaker will operate consistently. It prevents the member 48 from "hanging."

I claim:

1. In a circuit breaker of the enclosed type, an enclosing housing, a contact carrier positioned for longitudinal sliding movement therein, a pair of co-operating make and break contacts, one of said contacts being carried on said contact carrier, a transverse bar pivotally secured to said contact carrier, a manual operating means adapted to engage one end of said bar, a latch member adapted to engage the other end of said bar to prevent rotational movement thereof under normal operating conditions, said contact carrier being formed of two split sections, a flat mounting piece secured between said split sections and provided with an arm extending from the side of said split section, a flexible upright support secured at its bottom end to said arm, the top end of said flexible support serving to carry the latch member, a thermally responsive strip having one of its ends secured to the bottom of the flat support between the sections of the contact carrier, said strip extending outwardly from the side of said contact carrier and then upwardly in a direction parallel to the sides of the contact carrier, the free end of said thermal element being adapted to engage the latch member and remove it from the end of the transverse bar when the current through the thermal element exceeds a predetermined value, the latch member being otherwise free from restraint by the thermal element, the displacement of the latch member from the end of the transverse bar being adapted to allow movement of the circuit breaker contacts to the open circuit position.

2. In a circuit breaker of the enclosed type, an enclosing housing, a contact carrier positioned for longitudinal sliding movement therein, a pair of co-operating make and break contacts, one of said contacts being carried on said contact carrier, a transverse bar pivotally secured to said contact carrier, a manual operating means adapted to actuate one end of said bar, a latch member adapted to engage the other end of said bar to prevent rotational movement thereof under normal operating conditions, a flexible support supported on the contact carrier and extending along the side thereof, parallel to the side of the contact carrier, said support having the latch member mounted on its free end, a bimetallic strip carried by the contact carrier and extending parallel to said support, the free end of said bimetallic strip being adapted to actuate the latch member and remove it from the end of the transverse bar when the current through the bimetallic strip exceeds a predetermined value, a magnetic element, adapted to co-operate with said latch member and cause it to be displaced from the end of the transverse bar without interference from the thermal element when the current through the circuit breaker exceeds a predetermined value, displacement of the latch member from the end of the transverse bar re-

5

sulting in movement of the contacts of the circuit breaker to the open circuit position.

3. In a circuit breaker of the enclosed type, an enclosing housing, a contact carrier positioned for longitudinal sliding movement therein, a pair of co-operating make and break contacts, one of said contacts being carried on said contact carrier, a transverse bar pivotally secured to said contact carrier, a manual operating means adapted to operate one end of said bar, a latch member adapted to engage the other end of said bar to prevent rotational movement thereof under normal operating conditions of the circuit breaker, said latch member being of magnetic material and U-shaped and provided with a pin extending across it from one side to the other, a flexible support for said latch member carried by said contact carrier, a bimetallic strip supported on the contact carrier and extending parallel to the sides of the contact carrier, the free end of said bimetallic strip extending between the sides of said U-shaped latch member and normally between the bottom of the U-shaped latch member and the pin extending between the sides of the U-shaped latch member, said bimetallic

6

strip being adapted under abnormal current conditions to engage said pin and remove said latch member from the transverse bar, a magnetic element in said circuit breaker adapted to co-operate with the latch member and displace it from the end of the transverse bar without restraint from the bimetallic strip when the current through the circuit breaker exceeds a predetermined value, displacement of the latch member from the transverse bar resulting in the movement of the contacts to the open circuit position.

FLOYD S. GREEN.

#### REFERENCES CITED

- 15 The following references are of record in the file of this patent:

#### UNITED STATES PATENTS

Number	Name	Date
20 2,027,238	Lindstrom -----	Jan. 7, 1936
2,035,743	Frank et al. -----	Mar. 31, 1936
2,096,544	Jackson -----	Oct. 19, 1937
2,320,357	Platz et al. -----	June 1, 1943
2,328,767	Adam et al. -----	Sept. 7, 1943
25 2,210,260	Sachs -----	Aug. 6, 1940