

CATALOG



AFC
CABLE SYSTEMS®

CLICK ANYWHERE on THIS PAGE to
RETURN TO BX WIRING GUIDE at
InspectApedia.com

ARMORED CABLES PRODUCT CATALOG

AC, HCF and MC Cables • MC-Quik® & MC-Stat® • Specialty Application Cables



A PART OF

atkore
INTERNATIONAL

Installation Instructions for Traditional Type AC & MC Cables

Armored cable (Type AC) and metal clad cable (Type MC) provide a fast and efficient way of wiring both new construction and remodeling work. Their flexible metal armor provides mechanical protection of the electrical conductors while enabling them to bend around corners. The cables are pre-wired at the factory eliminating the need to pull conductors into a raceway, which in turn greatly reduces the possibility of conductor damage.

The National Electrical Code® has accepted AC and MC cables for decades, with statistics showing that they have an excellent fire safety record.

Because AC & MC cable can be fished for long distances, it is quick and easy to install. Its own weight can carry it between partitions and it can be run without concern for its contact with pipes or other obstructions.

Wire pullers, fish ropes or tapes, dispensers and lubricants are eliminated. AC & MC cable does the job in less space, with fewer bending restrictions as well as less cutting and connecting than most other wiring products.

Armored cable (Type AC) and Metal Clad cable (Type MC) have a flexible metal armor of similar outward appearance, but that is where the similarity ends. There are major differences in construction and uses permitted.

Armored (Type AC) Cable Construction

As described by the National Electrical Code® Article 320, armored cable Type AC is a “fabricated assembly of insulated conductors in a flexible metallic enclosure.”

Type AC cable is manufactured to UL Standard 4. It consists of 2 to 4 copper conductors in sizes 14 AWG to 1 AWG inside an interlocked metal armor of steel or aluminum construction. Type AC cable can have no more than four insulated conductors plus grounding conductors and cannot be manufactured larger than 1 AWG per UL 4.

A 16 AWG aluminum bonding wire is inside of, and in physical contact with, the metal armor providing a low-impedance fault-return path required for the operation of overcurrent protection devices. The bonding wire is unique to AC cable and allows the outer metal armor in conjunction with the bonding wire to be used as an equipment ground.

It is important to remember that the bare bond wire is not an equipment grounding conductor. It is the bond wire that, in combination with the interlocked metal armor, provides a low impedance equipment grounding path.

Each of the copper conductors is covered with a thermoplastic insulation (THHN with a 90°C rating) and are individually wrapped in a moisture resistant, fire retardant paper.

According to NEC® Article 320.40, an insulated (anti-short) bushing is required when installing Type AC cable. It is installed at the time of termination and designed to protect the conductors from damage. AFC provides bushings in bags packaged with the cable.

Metal Clad (Type MC) Cable Construction

As described by NEC® Article 330, Metal Clad Type MC cable is a “factory assembly of one or more insulated circuit conductors with or without optical fiber members enclosed in an armor of interlocked metal tape or a smooth or corrugated metallic sheath.”

Traditional Type MC cable is manufactured to UL Standard 1569. MC cables have 2 or more solid or stranded conductors in sizes 18 AWG and larger. The number of conductors allowed in an MC cable is not restricted by UL. The conductors may be of copper, aluminum or copper-clad aluminum.

The metal armor may be a smooth tube, a corrugated tube, or an interlocked metal armor. AFC Cable Systems manufactures MC cable with interlocked metal armor and copper conductors. The make-up of AFC Cable Systems’ 600 volt interlocked armor traditional MC cable consists of:

- Copper circuit and grounding conductors covered with thermoplastic insulation
- An overall polypropylene cable assembly tape
- An outer galvanized steel or aluminum interlocked armor

Unlike Type AC cable, the armor of interlocked Type MC cable is not an equipment grounding means and traditional Type MC cable requires a bare or green grounding conductor.

Differences between AC and traditional MC cables

	TYPE AC CABLE	TYPE MC CABLE
NUMBER OF CONDUCTORS	Limited to a maximum of 4 conductors plus a grounding conductor	Not limited to the number of conductors.
SIZE OF CONDUCTORS	14 AWG to 1 AWG	18 AWG or larger
GROUNDING	Contains a 16 AWG bond wire in constant contact with the metal armor allowing the armor and bond wire combination to be used as an equipment ground.	Does not contain a bonding wire and the armor is not an equipment ground, but supplements the internal grounding conductor equaling one grounding path.
CONDUCTOR WRAPPING	Individual conductors are wrapped in a moisture resistant, fire retardant paper.	Individual conductors are not wrapped in fire Retardant paper but do have an overall polypropylene assembly tape.

Along with these differences in construction, there are also differences in the uses permitted for these cables as discussed previously. (See pages 14 and 15 for installation details on new MCI-A type MC cables.)

Green Hospital Grade Type Cable

This additional ground allows HCF cables to be used in patient care areas of health care facilities (other than hazardous locations) including hospitals, nursing homes, dental offices, outpatient facilities and medical centers per NEC® 517.13.

The separate green grounding conductor satisfies the requirement of Article 517 that:

“In an area used for patient care, the grounding terminals of all receptacles and all non-current-carrying conductive surfaces of fixed electric equipment likely to become energized that are subject to personal contact, operating at over 100 volts, shall be grounded by an insulated copper conductor.”

The armor and bonding strip combination satisfies the requirement that:

“...all branch circuits serving patient care areas shall be provided with a ground path for fault current by installation in a metal raceway system or cable assembly. The metal raceway system, or cable armor or sheath assembly, shall itself qualify as an equipment grounding return path in accordance with Section 250.118.”

(NOTE: Read NEC® 517.30(C)(3)(3) for complete details on wiring of emergency healthcare circuits).

Installing AC & MC Cable

Type AC & MC cable is installed after the rough-in phase of locating and setting all boxes and enclosures. Rough-in occurs when all the interior and exterior walls are framed but before the sheet rock is installed.

The first step in the rough-in phase is to determine the number of home run circuits and from where the wiring will originate. Once this is done, time should be taken to determine the best and shortest routes for each cable run. Long runs of spider web type routing not only require more cable, but also increase voltage drop. This is very important to consider when locating boxes for receptacles, lights and switches. If long runs are required, oversizing the circuit conductors is recommended to limit voltage drop.

MC or AC Cable Installation

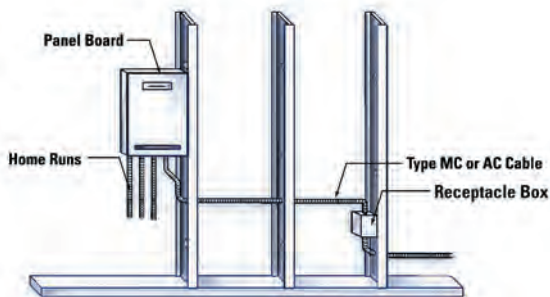

AC & MC cable is available on reels and in coils. If using a reel, simply draw the cable from the end of the reel. If using a coil, draw the cable from the center of the coil to prevent kinking.



Bridging Cable Across Open Spaces

In general, AC and MC cable must hug the surface it is wired over. The NEC® prohibits bridging across open spaces with the following five exceptions:

- 1) When the cable is fished.
- 2) When flexibility is required, a box may be installed near a motor or appliance using a short piece of free AC cable up to 24 inches long, between the box and motor or appliance.
- 3) Lengths of not more than 6 feet from the last point of support for connections within an accessible ceiling to lighting fixtures or equipment.
- 4) Where installed in cable trays.
- 5a) For Type AC cable in other than vertical runs through holes or notches in framing members where distance between members does not exceed 4½ feet and is securely fastened in place by an approved means within 12 inches of each box, cabinet, conduit body or other cable termination.
- 5b) For Type MC cable in other than vertical runs through holes or notches in framing members where the distance between members does not exceed 6 feet. Cables containing four or fewer conductors sized no larger than AWG 10 must be secured within 12 inches of each box, cabinet, fitting or other cable termination.

Bending Radius

Care should be taken not to exceed the bending radius of the cables when routing around corners. According to NEC® Article 320.24, for AC cable, the radius of the curve of the inner edge of any bend shall not be less than 5 times the diameter of the cable. NEC® Article 330.24(B) states that for MC Cable, the radius shall not be less than 7 times the external diameter of the cable.



Supporting AC & MC Cables

All cable runs must be continuous from outlet to outlet. According to NEC® Article 320.30, AC cable must be supported and secured at intervals of 4 1/2 feet or less (unless routed through a framing member) and within 12 inches of every termination.

Supporting Type AC Cable

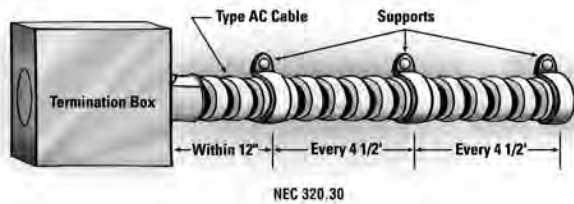

Supporting Type MC Cable

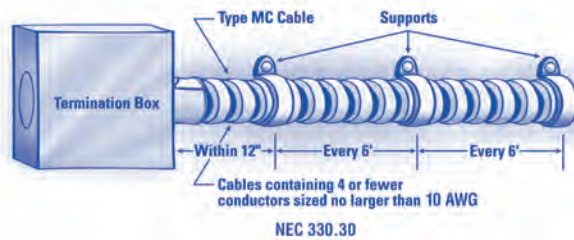

As noted, AC and MC cable support requirements are waived when the cable is fished. This is a major advantage of AC and MC cable in remodeling work over other wiring products that cannot be fished.

AC and MC cable may also be installed in cable tray, per NEC® Article 392. Cable is only required to be secured in this installation for vertical runs.

Terminating AC & traditional MC Cables

When terminating or splicing at a junction, outlet or switch box, cut the cable so that 6 inches of free conductor is left for connections or splices. Use an approved connector and insure a proper bond by firmly tightening the connectors to both the box and the cable. Please note, set screw connectors cannot be used with aluminum armor Type AC cable.

To terminate an AC cable, insert an anti-short bushing and bend back the exposed length of bonding wire. The bonding wire can be bent back before or after the bushing is inserted. There are several techniques used for this procedure as pictured on this page.



Insert the cable into the connector and secure the connector into the box. Be sure that the anti-short bushing is plainly visible in the connector for easy inspection. The same procedure is followed for traditional MC cable with the exception that there is no bonding wire. Although anti-short bushings are only required by the NEC® for AC cable, some manufacturers supply them for both cable types in the event that local codes override the NEC®.

Preparing AC Cable for Termination

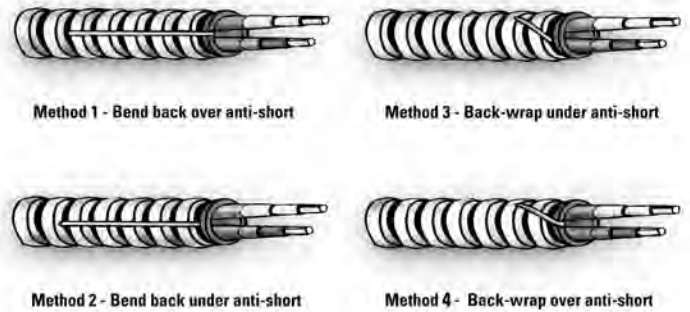

(Bond wire may also be cut off at the end of the armor)

Terminating AC & traditional MC Cables

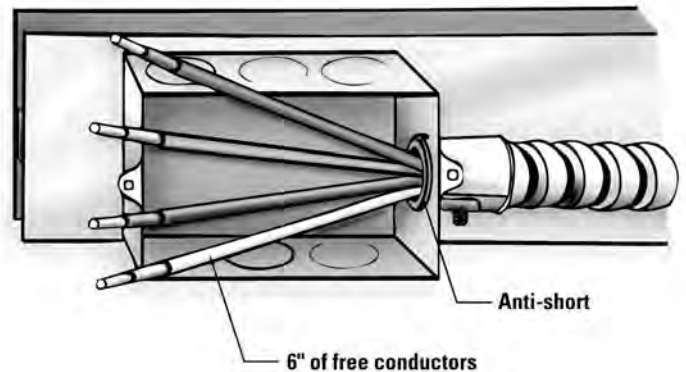

MC cable installed in a box with 6 inches of free conductors left for connections or splices.

Installation Instructions MC-Quik® Type MC Cable

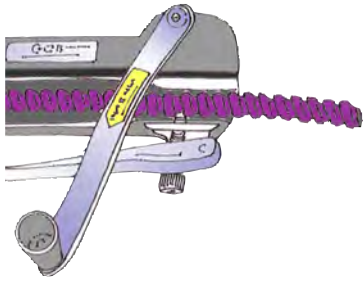

1. Cut the cable to length needed and remove armor approximately 6-inches from end using a rotary cutting tool designed for use with Interlocked Metal-Clad Cable and remove armor.



2. Separate the bare aluminum grounding/bonding conductor from the cable assembly by folding the bare aluminum grounding/bonding conductor back approximately 120°.



3. Cut the aluminum bare grounding/bonding conductor flush with the end of the armor using a suitable tool.

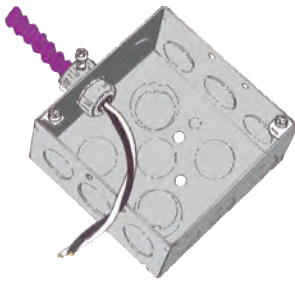

4. Use a fitting identified and listed* for use with a Metal-Clad Interlocking Armor Ground Cable (Type MCI-A), install the fitting per the manufacturer's instructions.

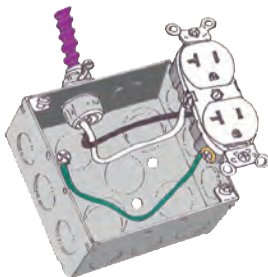

5. Bond the cable, fitting, box and wiring devices, as applicable, to provide an effective ground-fault current path.

NOTES:

1. The combination of the metal armor and the bare aluminum grounding/bonding conductor is the effective ground-fault path in accordance with NEC® 250.118(10)(b).
2. OPTIONAL INSTALLATION METHOD: Although not required, the bare aluminum grounding/bonding conductor may be terminated inside the box or enclosure provided the splices, connectors or terminations are suitable for the material of the conductor(s) to be used per NEC® 110.14.
3. *The fitting must be listed and marked for use with "Metal-Clad Interlocking Ground Cable Type" or "MCI-A" where the armor is a component of the equipment grounding path.
4. Cable has one grounding means - armor/bond-ground wire combination.

Installation Instructions MC-Stat® Type MC Cable

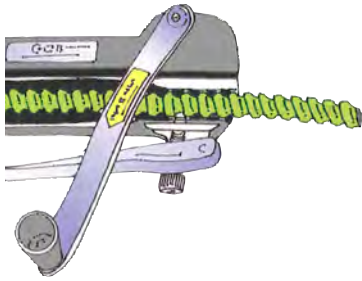

1. Cut the cable to length needed and remove armor approximately 6-inches from end using a rotary cutting tool designed for use with Interlocked Metal-Clad Cable and remove armor.

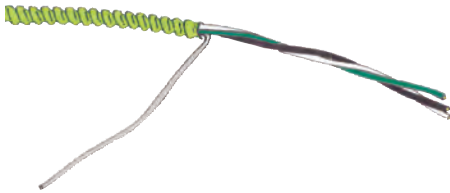

2. Separate the bare aluminum grounding/bonding conductor from the cable assembly by folding the bare aluminum grounding/bonding conductor back approximately 120°.

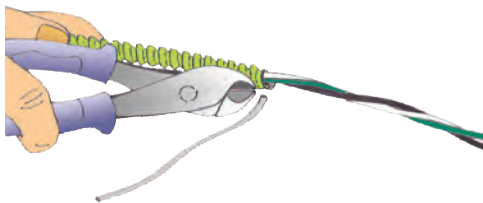

3. Cut the bare aluminum grounding/bonding conductor flush with the end of the armor using a suitable tool.

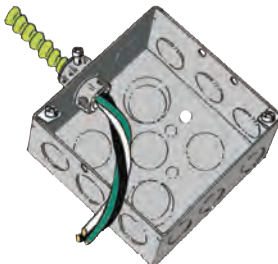

4. Use a fitting identified and listed* for use with a Metal-Clad Interlocking Armor Ground Cable (Type MCI-A), install the fitting per the manufacturer's instructions.

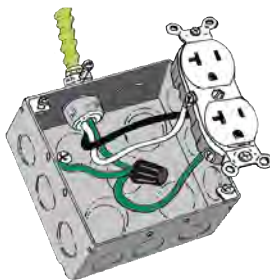

5. Bond the cable, fitting, box and wiring device, as applicable, to provide an effective ground-fault current path to comply with NEC® 517.13(A). Terminate the Green equipment grounding conductor to the device, the grounding screw or other grounding connection to comply with NEC® 517.13(B).

NOTES:

1. The combination of the metal armor and the bare aluminum grounding/bonding conductor is the effective ground-fault path in accordance with NEC® 250.118(10)(b).
2. OPTIONAL INSTALLATION METHOD: Although not required, the bare aluminum grounding/bonding conductor may be terminated inside the box or enclosure provided the splices, connectors or terminations are suitable for the material of the conductor(s) to be used per NEC® 110.14.
3. *The fitting must be listed and marked for use with "Metal-Clad Interlocking Ground Cable Type" or "MCI-A" where the armor is a component of the equipment grounding path.
4. The green insulated equipment grounding conductor is an effective ground-fault current path in accordance with NEC® 250.118(1).
5. Cable has two (2) grounding means:
 - (1) Armor/Bond-ground wire combination in accordance with 250.118(10)(b)
 - (2) Green insulated grounding conductor in accordance with 250.118(1).

CPID AFC's Custom Armoring Options

AFC offers a wide range of custom armoring options to suit a variety of application specific needs. Custom Armoring Services from AFC gives you better field performance by adding a layer or more with protective armors. Whether the application calls for power or fiber optic armor protection, electrical distribution or data applications, AFC is ready to service your requirements.

AFC's Custom Armoring Services provide steel strength protection and more. We can extrude color coded non-metallic coverings for moisture protection, plenum and riser environments and/or extremes in temperature, along with the mechanical strength of steel. Whatever your requirements may be, AFC is ready with quick lead times and quality.

AFC delivers and is dedicated to providing improved field productivity, minimized down times and easy cable identification.

Call today to find out about AFC's Custom Armoring Services – 508-985-1233

CPID Cable Protection

Cable Protection Identification (CPID™) refers to AFC's process of adding a protective inter-locking armor to customer supplied core (wire, cable or fiber optic).

As an option, an outer jacket of specially formulated PVC can be added to provide further protection.

CPID can often eliminate the costly and time consuming process of installing cable into conventional raceways.

Cables can be combined to further reduce installation costs.



960 Flaherty Drive
New Bedford, MA 02745
TOLL FREE / 800-757-6996
FAX / 508-998-1447

www.afcweb.com



UNISTRUT



Columbia-MBF



UNISTRUT
Construction



SprinkFLEX



SCI
STEEL COMPONENTS INC.

KAF-TECH

marco
cablemanagement



COBRASYSTEMS INC

FLEXICON
FLEXIBLE CONDUIT SOLUTIONS

Calconduit

Calbrite

Calbond

