

CLICK ANYWHERE on THIS PAGE to RETURN TO TYPE B-VENT CHIMNEYS at InspectApedia.com

VENTING TABLES

CATEGORY I CENTRAL FURNACES



COPYRIGHT © 1990
GAS APPLIANCE MANUFACTURERS ASSOCIATION

SPECIAL METAL-FAB UPDATE AS OF MARCH 2000

The venting tables within this booklet have now been included in the National Fuel Gas Code (NFPA 54/ANSI Z223.1-1999). That code may also be used to size venting systems for drafthood equipped central furnaces or for fan-assisted combustion system central furnaces.

GAMA VENTING TABLES FOR CATEGORY I CENTRAL FURNACES

This booklet contains new venting tables designed specifically for use with Category I central furnaces. These tables are unique, in that, industry wide venting tables now exist for fan-assisted combustion system central furnaces. Venting tables for these types of appliances are not contained in the National Fuel Gas Code (NFPA 54/ANSI Z223.1-1988).

All requirements contained in this booklet apply to both Category I drafthood equipped central furnaces as well as fan-assisted combustion system central furnaces. At no time should a venting system for a listed Category II, III, or IV central furnace be sized with these tables. The National Fuel Gas Code (NFPA 54/ANSI Z223.1-1988) may also be used to size venting systems for drafthood equipped central furnaces. However, at this time, the National Fuel Gas Code does not include alternate sizing methods for fan-assisted combustion systems. Therefore, until engineering data is developed to allow alternate sizing methods for Category I fan-assisted central furnaces, the enclosed venting tables must be used for fan-assisted combustion system central furnaces. These tables apply to venting single appliances and common venting multiple appliances in both metal and masonry chimneys.

The new venting tables were developed by Battelle under contract (GRI-5088-245-1728) to the Gas Research Institute (GRI). The computer program (VENT-II) developed by Battelle Columbus generated the venting tables in this booklet and this procedure has been accepted by the American Gas Association Laboratories as an appropriate engineering methodology for determining venting requirements of Category I central furnaces.

For your information, the general venting requirements listed in this booklet are not intended to be used as complete installation instructions and represent only a partial list of venting considerations.

For venting applications that fall outside the parameters of the new venting tables, refer to the furnace manufacturer's complete installation instructions, the specific vent manufacturer's complete installation instructions, and state and local codes.

GRI DISCLAIMER

LEGAL NOTICE: This information is, in part, a result of work performed by Battelle under the sponsorship of the Gas Research Institute (GRI). Neither GRI, members of GRI, nor any person acting on behalf of either:

- a. Makes any warranty or representation, express or implied, with respect to the accuracy, completeness, or usefulness of this information, or that the use of any apparatus, method, or process disclosed may not infringe privately owned rights; or
- b. Assumes any liability with respect to the use of, or for damages resulting from the use of, any information, apparatus, method, or process disclosed.

VENTING REQUIREMENTS FOR CATEGORY I APPLIANCES

I. INTRODUCTION

This booklet contains the current definitions, instructions, and tables necessary to vent today's modern Category I Gas Fired Appliance. A variety of definitions of new terms describing today's gas appliances are included to supplement the actual venting tables which have been generated to correctly vent various combinations of Category I Appliances using Type B or single-wall metal vent connectors attached to Type B vents or masonry chimneys. Tables are also included covering similar venting material combinations when applied to common venting arrangements of two or more appliances.

Finally, a series of examples are presented demonstrating how the vent tables are used to size the vent connector and the vertical vent for a variety of typical applications.

I. DEFINITION OF TERMS

"Fan Assisted Combustion System" An appliance equipped with an integral mechanical means to either draw or force products of combustion through the combustion chamber and/or heat exchanger.

"FAN Min" refers to the minimum appliance input rating of a Category I appliance with a fan-assisted combustion system that could be attached to the vent.

"FAN Max" refers to the maximum appliance input rating of a Category I appliance with a fan-assisted combustion system that could be attached to the vent.

"NAT Max" refers to the maximum appliance input rating of a Category I appliance equipped with a draft hood that could be attached to the vent. There are no minimum appliance input ratings for draft hood equipped appliances.

"FAN+FAN" refers to the maximum combined input rating of two or more fan-assisted appliances attached to the common vent.

"FAN+NAT" refers to the maximum combined input rating of one or more fan-assisted appliance and one or more draft hood-equipped appliance attached to the common vent.

"FAN+NAT" refers to the maximum combined input rating of two or more draft hood-equipped appliances attached to the common vent.

"NR" means not recommended due to potential for condensate formation and/or pressurization of the venting system.

"NR" means not applicable due to physical or geometric constraints.

DraftHood A device built into an appliance, or made a part of the vent connector from an appliance, which is designed to (1) provide for the ready escape of the flue gases from the appliance in the event of no draft, backdraft, or stoppage beyond the draft hood, (2) prevent a backdraft from entering the appliance, and (3) neutralize the effect of stack action of the chimney or gas vent upon the operation of the appliance.

Vent A passageway used to convey flue gases from gas utilization equipment, or their vent connectors, to the outside atmosphere.

Vent Connector The pipe or duct which connects a fuel-gas burning appliance to a vent or chimney.

Flue Collar That portion of an appliance designed for the attachment of a draft hood, vent connector, or venting system.

Categorized Vent Diameter The minimum vent diameter permissible for Category I appliances to maintain a nonpositive vent static pressure when tested in accordance with nationally recognized standards.

III. GENERAL VENTING REQUIREMENTS

All requirements contained in this document apply to both Category I draft hood equipped and fan-assisted combustion appliances. At no time should a venting system for a listed Category II, III, or IV appliance be sized with these Tables. The alternate sizing methods described in the National Fuel Gas Code (NFPA54/ANSI Z223.1-1988) may also be used to size the venting system for a draft hood equipped appliance. At this time, alternate sizing methods have not been developed for fan-assisted appliances. Therefore, until engineering data is developed to allow alternate sizing methods for Category I fan-assisted appliances, the vent tables must be used.

1) The venting tables included in this instruction apply to vents and chimneys internal to the structure below the roof line. Exterior chimneys or vents not enclosed by the structure or a chase below the roof line may experience continuous condensation depending on locality. Consult local gas utility, appliance manufacturer and/or local codes. A chimney with one or more sides exposed to the outside of the structure is considered to be an exterior chimney. A Type B or listed chimney lining system passing through an unused masonry chimney flue is not considered to be exposed to the outdoors.

2) If the vent or connector size determined from the tables is smaller than the appliance draft-hood outlet or flue collar, the smaller size may be used provided:

- a) The total vent height "H" is at least 10 FT.
- b) Vents or connectors for appliance draft-hood outlets or flue collars 12 inches in diameter or smaller are not reduced more than one table size (e.g. 12 inches to 10 inches is a one size reduction).
- c) Vents or connectors for appliance draft-hood or flue collars above 12 inches in diameter are not reduced more than two table sizes (e.g. 24 inches to 20 inches is a two size reduction).
- d) The maximum capacity listed in the tables for a fan-assisted appliance is reduced by 10% (0.90 x maximum capacity).
- e) The draft hood outlet is greater than 4 inches in diameter. Do not connect a 3 inch diameter vent or connector to a 4 inch diameter draft hood outlet. This provision does not apply to fan-assisted appliances.

3) Single appliance venting configurations with zero lateral lengths, Tables 1 & 2, are assumed to have no elbows in the vent system. For all other vent configurations, the vent system is assumed to have two 90° elbows. For each additional 90° elbow, or equivalent* beyond two, the maximum capacity listed in the venting table should be reduced by 10 percent (0.90 x maximum listed capacity).

* Two 45 elbows are equivalent to one 90°

4) The common venting Tables 3, 4, 7, & 8 were generated using a maximum horizontal vent connector length of 1 1/2 feet (18 inches) for each inch of connector diameter as follows:

| CONNECTOR DIAMETER (INCHES) | MAXIMUM HORIZONTAL CONNECTOR LENGTH (FEET) |
|-----------------------------|--|
| 3 | 4 1/2 |
| 4 | 6 |
| 5 | 7 1/2 |
| 6 | 9 |
| 7 | 10 1/2 |
| 8 | 12 |
| 9 | 13 1/2 |
| 10 | 15 |
| 12 | 18 |
| 14 | 21 |
| 16 | 24 |
| 18 | 27 |
| 20 | 30 |
| 22 | 33 |
| 24 | 36 |

The vent connector should be routed to the vent utilizing the shortest possible route. Connectors with longer horizontal lengths than those listed above are possible under the following conditions:

- a) The maximum capacity (Fan Max. or Nat Max.) of the vent connector shall be reduced 10% for each additional multiple of the length listed above. For example, the maximum length listed above for a 4 inch connector is 6 feet. With a connector length greater than 6 feet but not exceeding 12 feet, the maximum capacity must be reduced by 10% (0.90 x maximum vent connector capacity). With a connector length greater than 12 feet but not exceeding 18 feet, the maximum capacity must be reduced by 20% (0.80 x maximum vent capacity).

b) The minimum capacity (Fan Min.) shall be determined by referring to the corresponding single appliance table (Tables 1 and 2). In this case, for each appliance the entire vent connector and common vent from the appliance to the vent termination would be treated as a single appliance vent, as if the other appliances were not present.

5) If vent connectors are combined prior to entering the common vent, the maximum common vent capacity listed in the common venting tables must be reduced by 10%, the equivalent of 1 (one) 90° elbow (0.90 x maximum common vent capacity). See Figure 7. The horizontal length of the common vent connector manifold (L) should not exceed 1-1/2 feet (18 inches) for each inch of common vent connector manifold diameter.

6) If the common vertical vent is offset as shown in Figure 8, the maximum common vent capacity listed in the common venting tables should be reduced by 20%, the equivalent of 2 (two) 90° elbows (0.80 x maximum common vent capacity). The horizontal length of the offset shall not exceed 1 1/2 feet for each inch of common vent diameter.

7) The common vent diameter must always be at least as large as the largest vent connector diameter. All interconnection fittings must also be the same size as the common vent.

8) Type B gas vents shall terminate above the roof surface with a listed cap or a listed roof assembly in accordance with the terms of their respective listings and the vent manufacturer's instructions.

VENT CAPS 12" AND SMALLER

Listed gas venting systems using listed vent caps 12" and smaller in size may terminate in accordance with the VENT TERMINATION TABLE. (SEE FIGURE 1)

VENT CAPS LARGER THAN 12"

Listed vent caps larger than 12" must be located at least 2 feet above the highest point and at least 2 feet higher than any portion of a building within a horizontal distance of 10 Feet. (SEE FIGURE 2)

9) Use sea level input rating when determining maximum capacity for high altitude installation. Use actual input rating for determining minimum capacity for high altitude installation.

GAS VENT TERMINATION TABLE

| ROOF PITCH | MINIMUM HEIGHT |
|---------------------|----------------|
| FLAT TO 7/12 | 1.0 FEET* |
| OVER 7/12 TO 8/12 | 1.5 FEET |
| OVER 8/12 TO 9/12 | 2.0 FEET |
| OVER 9/12 TO 10/12 | 2.5 FEET |
| OVER 10/12 TO 11/12 | 3.25 FEET |
| OVER 11/12 TO 12/12 | 4.0 FEET |
| OVER 12/12 TO 14/12 | 5.0 FEET |
| OVER 14/12 TO 16/12 | 6.0 FEET |
| OVER 16/12 TO 18/12 | 7.0 FEET |
| OVER 18/12 TO 20/12 | 7.5 FEET |
| OVER 20/12 TO 21/12 | 8.0 FEET |

*THIS REQUIREMENT COVERS MOST INSTALLATIONS

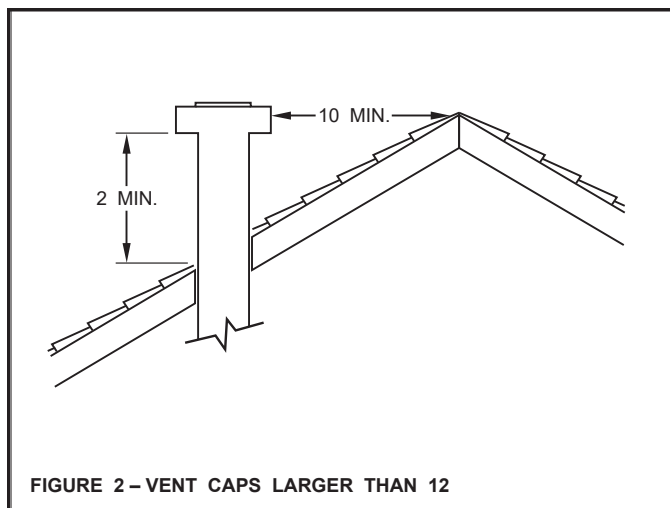
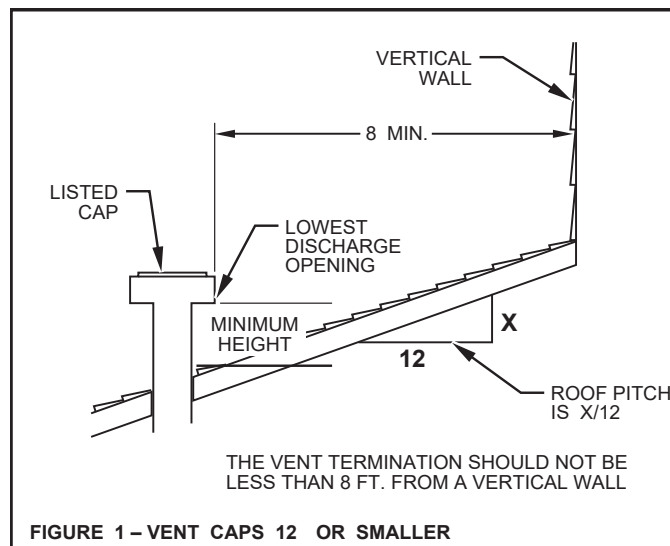

- 10) No portion of the venting system can extend into, or pass through any circulating air duct or plenum.
- 11) All vent pipe passing through floors, walls, and ceilings must be installed with the listed clearance to combustibles and be fire stopped according to local codes. In the absence of local codes, refer to NFGC (Z223.1)
- 12) Vent connectors serving Category I appliances shall not be connected to any portion of mechanical draft systems operating under positive pressure such as Category III or IV Venting Systems.
- 13) A Category I appliance must never be connected to a chimney that is servicing a solid fuel appliance. If a fireplace chimney flue is used to vent this appliance, the fireplace opening must be permanently sealed.
- 14) A vent connector shall be supported without any dips or sags and shall slope a minimum of 1/4 inch per lineal foot of connector, back towards the appliance.
- 15) Vent connectors shall be firmly attached to draft hood outlets or flue collars by sheet-metal screws or other approved means, except vent connectors of listed Type B vent material which shall be assembled in accordance with the manufacturer's instructions. Joints between sections of single wall connector piping shall be fastened by sheet-metal screws or other approved means.
- 16) When the vent connector used for Category I appliances must be located in or pass through a crawl space or other area which may be cold, that portion of the vent connector shall be of listed double-wall Type B vent material or material having equivalent insulation qualities.
- 17) The entire length of single wall metal vent connector shall be readily accessible for inspection, cleaning, and replacement.
- 18) For appliances with more than one input rate, the minimum vent or connector (Fan Min) capacity determined from the tables shall be less than the lowest appliance input rating and the maximum vent or connector (Fan or Nat Max.) capacity determined from the tables shall be greater than the highest appliance input rating.

19) For single appliance vents:

- a) If the vertical vent or tile lined chimney has a larger diameter or flow area than the vent connector, use the vertical vent diameter to determine the minimum vent capacity and the vent connector diameter to determine the maximum vent capacity. The flow area of the vertical vent, however, shall not exceed 7 times the flow area of the listed appliance categorized vent area, draft hood outlet area or flue collar area unless designed in accordance with approved engineering methods. See Table 9 for calculated areas.
- b) For multiple appliance vents: The flow area of the largest section of vertical vent or chimney shall not exceed 7 times the smallest listed appliance categorized vent area, flue collar area, or draft hood outlet area unless designed in accordance with approved engineering methods. See Table for calculated areas.

$$\text{Maximum vent or tile lined chimney flow area} = \frac{\text{TT } (D^*)^2}{\text{TT } (D^*)^2} \times 7$$

*Draft hood outlet diameter, flue collar diameter, or listed appliance categorized vent diameter.

- c) In no case, shall the vent connector be upsized more than 2 consecutive table size diameters over the size of the draft hood outlet, flue collar outlet, or listed appliance categorized vent. Example: An appliance with a 4 inch diameter flue outlet collar or draft hood outlet cannot be vented with a connector diameter larger than 6 inches.

- 20) Masonry chimneys used to vent Category I central furnaces must be either tiled or lined with a listed metal lining system or dedicated gas vent. Unlined masonry chimneys are prohibited. (See Note 1).
- 21) A fan assisted furnace may be common vented into an existing masonry chimney provided:
 - a) The chimney is currently serving at least one draft hood equipped appliance.
 - b) The vent connectors and chimney are sized in accordance with Tables 7 & 8.

SINGLE APPLIANCE VENTING OF A FAN ASSISTED FURNACE INTO A TILE LINED, MASONRY CHIMNEY IS PROHIBITED. THE CHIMNEY MUST FIRST BE LINED WITH EITHER TYPE B VENT SIZED IN ACCORDANCE WITH TABLES 1 OR 2 OR A LISTED SINGLE WALL, METAL LINING SYSTEM, SIZED IN ACCORDANCE WITH NOTE 22.

- 22) Listed, corrugated metallic chimney liner systems in masonry chimneys shall be sized by using Tables 1 or 2 for dedicated venting and Tables 3 or 4 for common venting with the maximum capacity reduced by 20% (0.80 x maximum capacity) and the minimum capacity as shown in the applicable table. Corrugated metal vent systems installed with bends or offsets require additional reduction of the vent maximum capacity (See Note 6).
- 23) For multiple units of gas utilization equipment all located on one floor, available total height "H" is measured from the highest drafthood outlet or flue collar up to the level of the cap or terminal. Connector rise "R" is measured from the drafthood outlet or flue collar to the level where the vent gas streams come together.(Not applicable to multi-story).
- 24) For multistory installations, available total height for each segment of the system "H" is the vertical distance between the highest draft-hood outlet or flue collar entering that segment and the centerline of the next higher interconnection tee (See Figure 13).
- 25) The size of the lowest connector and of the vertical vent leading to the lowest interconnection of a multi-story system must be in accordance with Table 1 OR 2, for available total height "H" up to the lowest interconnection (See Figure 14).
- 26) Common vents in multi-story systems shall be type B when used in multi-story systems and have no offsets.
- 27) Numbers followed by an asterisk (*) in Table 6, indicate the possibility of continuous condensation, depending on locality. Consult appliance manufacturer, local serving gas supplier, and/or authority having jurisdiction.
- 28) In a single run of vent or vent connector, more than one diameter and type of pipe are permitted to be used, provided that all the sizes are permitted by the tables.
- 29) If the desired vent height and connector rise are between the table entries, linear interpolation is permitted for calculation of the permissible appliance input ratings. Extrapolation beyond the table entries is not recommended. (See Example 7)
- 30) All combinations of pipe sizes, single-wall, and double-wall metal pipe are allowed within any connector run(s) or within the common vent provided ALL of the appropriate tables permit ALL of the desired sizes and types of pipe, as if they were used for the entire length of the subject connector or vent. If single-wall and Type B double-wall metal pipe are used for vent connectors, the common vent must be sized using Table 4.
- 31) Locate draft hood outlet or flue collar of smallest input appliance closest to or under common vent.
- 32) When vent table permits more than one diameter of pipe to be used for a connector or vent, the smallest permitted diameter should be preferred.

TYPICAL VENTING APPLICATIONS

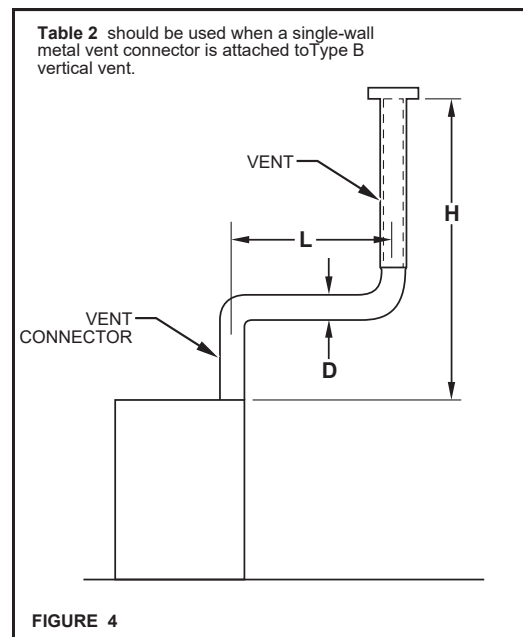
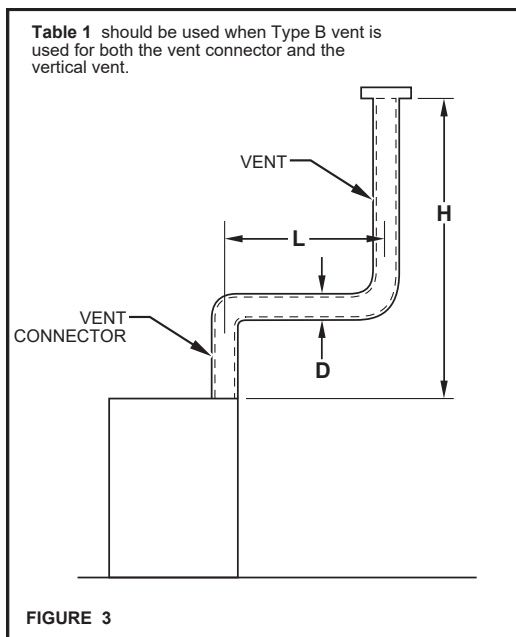

Table 3 should be used when Type B vent connectors are attached to a Type B common vent.

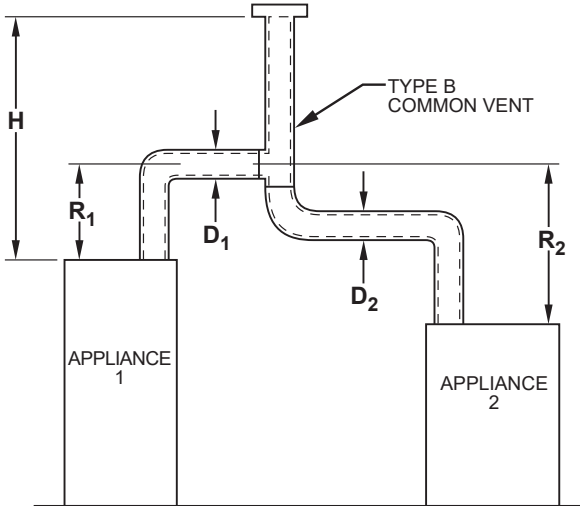

FIGURE 5

Table 4 should be used when single-wall metal vent connectors are attached to a Type B common vent.

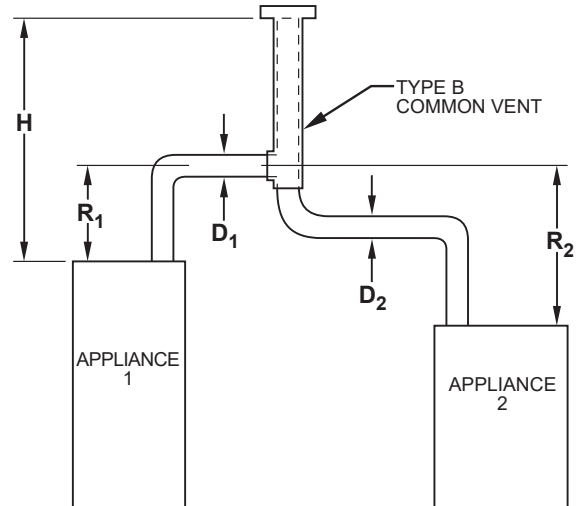

FIGURE 6

Schematic Diagram showing a typical manifolded common vent section "L" of the vent connector. (See Note 5)

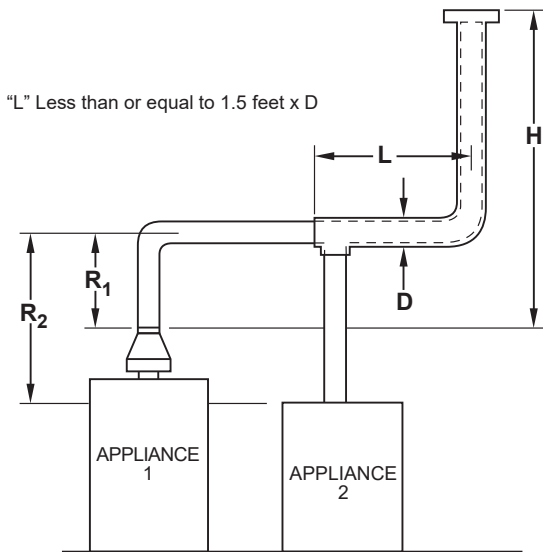

FIGURE 7

Schematic Diagram showing offset in the common vent section of the vertical vent. (See Note 6)

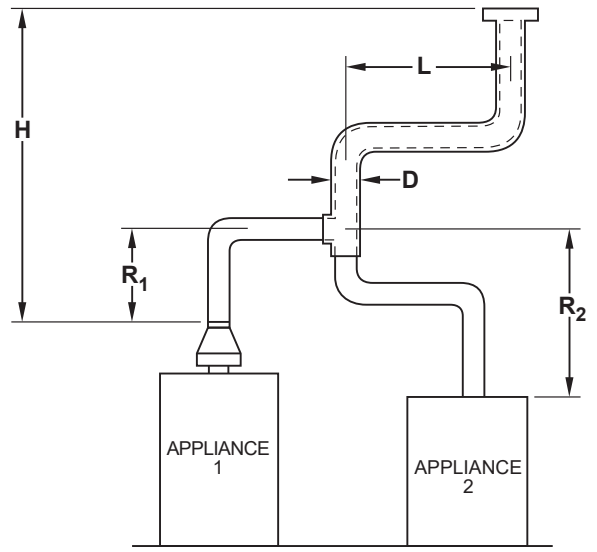

FIGURE 8

Table 5 shall be used when a Type B, double-wall vent connector is attached to a tile lined masonry chimney.

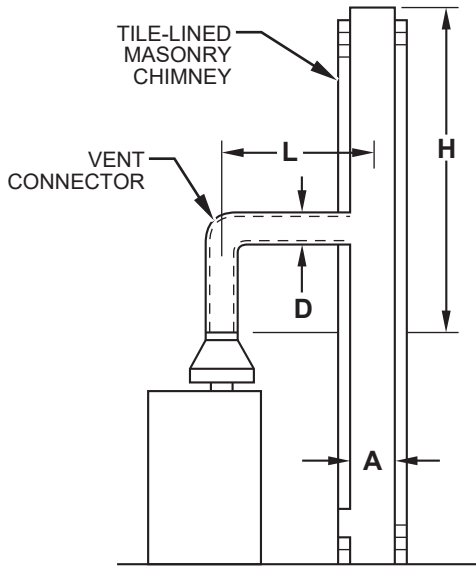

FIGURE 9

Table 6 shall be used when a single-wall metal vent connector is attached to a tile lined masonry chimney.

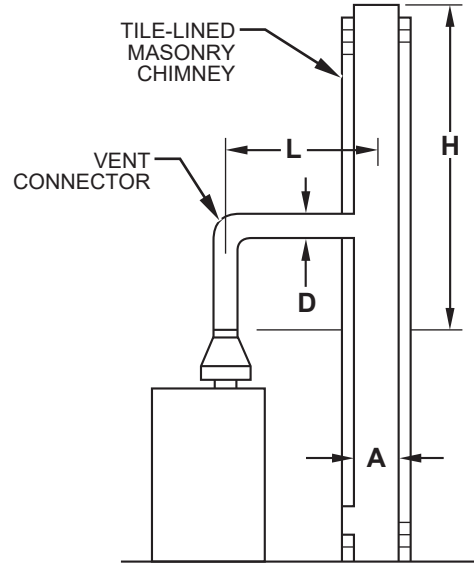

FIGURE 10

Table 7 shall be used when Type B double-wall vent connectors are attached to a tile lined masonry chimney.

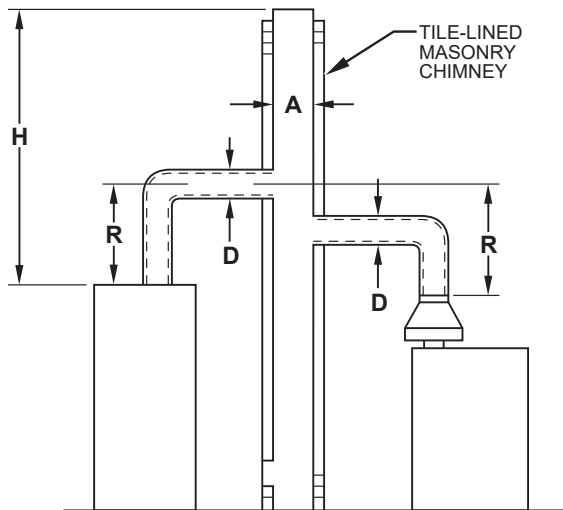

FIGURE 11

Table 8 shall be used when single-wall metal vent connectors are attached to a tile lined masonry chimney.

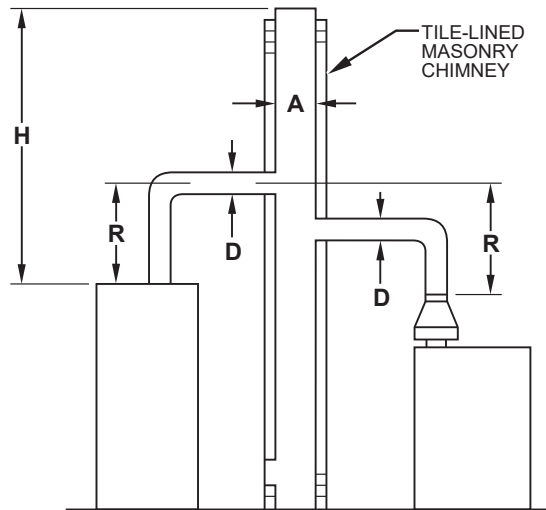

FIGURE 12

VENT TABLES

Capacity of Type B Double-Wall Vents with Type B Double-Wall Connectors
Serving a Single Category I Appliance

TABLE 1

| Height H (ft) | | Lateral L (ft) | | Vent and Connector Diameter - D (inches) | | | | | | | | | | | | | | | | | | | | | |
|---------------------|----|----------------------|-----|---|-----|-----|-----|-----|-----|-----|-----|-----|-----|-----|-----|-----|-----|------|-----|-----|------|------|-----|-----|-----|
| | | | | 3" | | | 4" | | | 5" | | | 6" | | | 7" | | | 8" | | | 9" | | | |
| | | | | Appliance Input Rating in Thousands of Btu Per Hour | | | | | | | | | | | | | | | | | | | | | |
| | | | | FAN | | | NAT | | | FAN | | | NAT | | | FAN | | | NAT | | | FAN | | | NAT |
| | | Min | Max | Max | Min | Max | Max | Min | Max | Max | Min | Max | Max | Min | Max | Max | Min | Max | Max | Min | Max | Max | Min | Max | Max |
| 6 | 0 | 0 | 78 | 46 | 0 | 152 | 86 | 0 | 251 | 141 | 0 | 375 | 205 | 0 | 524 | 285 | 0 | 698 | 370 | 0 | 897 | 470 | | | |
| | 2 | 13 | 51 | 36 | 18 | 97 | 67 | 27 | 157 | 105 | 32 | 232 | 157 | 44 | 321 | 217 | 53 | 425 | 285 | 63 | 543 | 370 | | | |
| | 4 | 21 | 49 | 34 | 30 | 94 | 64 | 39 | 153 | 103 | 50 | 227 | 153 | 66 | 316 | 211 | 79 | 419 | 279 | 93 | 536 | 362 | | | |
| | 6 | 25 | 46 | 32 | 36 | 91 | 61 | 47 | 149 | 100 | 59 | 223 | 149 | 78 | 310 | 205 | 93 | 413 | 273 | 110 | 530 | 354 | | | |
| 8 | 0 | 0 | 84 | 50 | 0 | 165 | 94 | 0 | 276 | 155 | 0 | 415 | 235 | 0 | 583 | 320 | 0 | 780 | 415 | 0 | 1006 | 537 | | | |
| | 2 | 12 | 57 | 40 | 16 | 109 | 75 | 25 | 178 | 120 | 28 | 263 | 180 | 42 | 365 | 247 | 50 | 483 | 322 | 60 | 619 | 418 | | | |
| | 5 | 23 | 53 | 38 | 32 | 103 | 71 | 42 | 171 | 115 | 53 | 255 | 173 | 70 | 356 | 237 | 83 | 473 | 313 | 99 | 607 | 407 | | | |
| | 8 | 28 | 49 | 35 | 39 | 98 | 66 | 51 | 164 | 109 | 64 | 247 | 165 | 84 | 347 | 227 | 99 | 463 | 303 | 117 | 596 | 396 | | | |
| 10 | 0 | 0 | 88 | 53 | 0 | 175 | 100 | 0 | 295 | 166 | 0 | 447 | 255 | 0 | 631 | 345 | 0 | 847 | 450 | 0 | 1096 | 585 | | | |
| | 2 | 12 | 61 | 42 | 17 | 118 | 81 | 23 | 194 | 129 | 26 | 289 | 195 | 40 | 402 | 273 | 48 | 533 | 355 | 57 | 684 | 457 | | | |
| | 5 | 23 | 57 | 40 | 32 | 113 | 77 | 41 | 187 | 124 | 52 | 280 | 188 | 68 | 392 | 263 | 81 | 522 | 346 | 95 | 671 | 446 | | | |
| | 10 | 30 | 51 | 36 | 41 | 104 | 70 | 54 | 176 | 115 | 67 | 267 | 175 | 88 | 376 | 245 | 104 | 504 | 330 | 122 | 651 | 427 | | | |
| 15 | 0 | 0 | 94 | 58 | 0 | 191 | 112 | 0 | 327 | 187 | 0 | 502 | 285 | 0 | 716 | 390 | 0 | 970 | 525 | 0 | 1263 | 682 | | | |
| | 2 | 11 | 69 | 48 | 15 | 136 | 93 | 20 | 226 | 150 | 22 | 339 | 225 | 38 | 475 | 316 | 45 | 633 | 414 | 53 | 815 | 544 | | | |
| | 5 | 22 | 65 | 45 | 30 | 130 | 87 | 39 | 219 | 142 | 49 | 330 | 217 | 64 | 463 | 300 | 76 | 620 | 403 | 90 | 800 | 529 | | | |
| | 10 | 29 | 59 | 41 | 40 | 121 | 82 | 51 | 206 | 135 | 64 | 315 | 208 | 84 | 445 | 288 | 99 | 600 | 386 | 116 | 777 | 507 | | | |
| | 15 | 35 | 53 | 37 | 48 | 112 | 76 | 61 | 195 | 128 | 76 | 301 | 198 | 98 | 429 | 275 | 115 | 580 | 373 | 134 | 755 | 491 | | | |
| 20 | 0 | 0 | 97 | 61 | 0 | 202 | 119 | 0 | 349 | 202 | 0 | 540 | 307 | 0 | 776 | 430 | 0 | 1057 | 575 | 0 | 1384 | 752 | | | |
| | 2 | 10 | 75 | 51 | 14 | 149 | 100 | 18 | 250 | 166 | 20 | 377 | 249 | 33 | 531 | 346 | 41 | 711 | 470 | 50 | 917 | 612 | | | |
| | 5 | 21 | 71 | 48 | 29 | 143 | 96 | 38 | 242 | 160 | 47 | 367 | 241 | 62 | 519 | 337 | 73 | 697 | 460 | 86 | 902 | 599 | | | |
| | 10 | 28 | 64 | 44 | 38 | 133 | 89 | 50 | 229 | 150 | 62 | 351 | 228 | 81 | 499 | 321 | 95 | 675 | 443 | 112 | 877 | 576 | | | |
| | 15 | 34 | 58 | 40 | 46 | 124 | 84 | 59 | 217 | 142 | 73 | 337 | 217 | 94 | 481 | 308 | 111 | 654 | 427 | 129 | 853 | 557 | | | |
| | 20 | 48 | 52 | 35 | 55 | 116 | 78 | 69 | 206 | 134 | 84 | 322 | 206 | 107 | 464 | 295 | 125 | 634 | 410 | 145 | 830 | 537 | | | |
| 30 | 0 | 0 | 100 | 64 | 0 | 213 | 128 | 0 | 374 | 220 | 0 | 587 | 336 | 0 | 853 | 475 | 0 | 1173 | 650 | 0 | 1548 | 855 | | | |
| | 2 | 9 | 81 | 56 | 13 | 166 | 112 | 14 | 283 | 185 | 18 | 432 | 280 | 27 | 613 | 394 | 33 | 826 | 535 | 42 | 1072 | 700 | | | |
| | 5 | 21 | 77 | 54 | 28 | 160 | 108 | 36 | 275 | 176 | 45 | 421 | 273 | 58 | 600 | 385 | 69 | 811 | 524 | 82 | 1055 | 688 | | | |
| | 10 | 27 | 70 | 50 | 37 | 150 | 102 | 48 | 262 | 171 | 59 | 405 | 261 | 77 | 580 | 371 | 91 | 788 | 507 | 107 | 1028 | 668 | | | |
| | 15 | 33 | 64 | NR | 44 | 141 | 96 | 57 | 249 | 163 | 70 | 389 | 249 | 90 | 560 | 357 | 105 | 765 | 490 | 124 | 1002 | 648 | | | |
| | 20 | 56 | 58 | NR | 53 | 132 | 90 | 66 | 237 | 154 | 80 | 374 | 237 | 102 | 542 | 343 | 119 | 743 | 473 | 139 | 977 | 628 | | | |
| | 30 | NR | NR | NR | 73 | 113 | NR | 88 | 214 | NR | 104 | 346 | 219 | 131 | 507 | 321 | 149 | 702 | 444 | 171 | 929 | 594 | | | |
| 50 | 0 | 0 | 101 | 67 | 0 | 216 | 134 | 0 | 397 | 232 | 0 | 633 | 363 | 0 | 932 | 518 | 0 | 1297 | 708 | 0 | 1730 | 952 | | | |
| | 2 | 8 | 86 | 61 | 11 | 183 | 122 | 14 | 320 | 206 | 15 | 497 | 314 | 22 | 715 | 445 | 26 | 975 | 615 | 33 | 1276 | 813 | | | |
| | 5 | 20 | 82 | NR | 27 | 177 | 119 | 35 | 312 | 200 | 43 | 487 | 308 | 55 | 702 | 438 | 65 | 960 | 605 | 77 | 1259 | 798 | | | |
| | 10 | 26 | 76 | NR | 35 | 168 | 114 | 45 | 299 | 190 | 56 | 471 | 298 | 73 | 681 | 426 | 86 | 935 | 589 | 101 | 1230 | 773 | | | |
| | 15 | 59 | 70 | NR | 42 | 158 | NR | 54 | 287 | 180 | 66 | 455 | 288 | 85 | 662 | 413 | 100 | 911 | 572 | 117 | 1203 | 747 | | | |
| | 20 | NR | NR | NR | 50 | 149 | NR | 63 | 275 | 169 | 76 | 440 | 278 | 97 | 642 | 401 | 113 | 888 | 556 | 131 | 1176 | 722 | | | |
| | 30 | NR | NR | NR | 69 | 131 | NR | 84 | 250 | NR | 99 | 410 | 259 | 123 | 605 | 376 | 141 | 844 | 522 | 161 | 1125 | 670 | | | |
| 100 | 0 | NR | NR | NR | 0 | 218 | NR | 0 | 407 | NR | 0 | 665 | 400 | 0 | 997 | 560 | 0 | 1411 | 770 | 0 | 1908 | 1040 | | | |
| | 2 | NR | NR | NR | 10 | 194 | NR | 12 | 354 | NR | 13 | 566 | 375 | 18 | 831 | 510 | 21 | 1155 | 700 | 25 | 1536 | 935 | | | |
| | 5 | NR | NR | NR | 26 | 189 | NR | 33 | 347 | NR | 40 | 557 | 369 | 52 | 820 | 504 | 60 | 1141 | 692 | 71 | 1519 | 926 | | | |
| | 10 | NR | NR | NR | 33 | 182 | NR | 43 | 335 | NR | 53 | 542 | 361 | 68 | 801 | 493 | 80 | 1118 | 679 | 94 | 1492 | 910 | | | |
| | 15 | NR | NR | NR | 40 | 174 | NR | 50 | 321 | NR | 62 | 528 | 353 | 80 | 782 | 482 | 93 | 1095 | 666 | 109 | 1465 | 895 | | | |
| | 20 | NR | NR | NR | 47 | 166 | NR | 59 | 311 | NR | 71 | 513 | 344 | 90 | 763 | 471 | 105 | 1073 | 653 | 122 | 1438 | 880 | | | |
| | 30 | NR | NR | NR | NR | NR | NR | 78 | 290 | NR | 92 | 483 | NR | 115 | 726 | 449 | 131 | 1029 | 627 | 149 | 1387 | 849 | | | |
| | 50 | NR | NR | NR | NR | NR | NR | NR | NR | NR | 147 | 428 | NR | 180 | 651 | 405 | 197 | 944 | 575 | 217 | 1288 | 787 | | | |

VENT TABLES

Capacity of Type B Double-Wall Vents with Type B Double-Wall Connectors
Serving a Single Category I Appliance

TABLE 1 (Cont'd)

| Height H (ft) | | Lateral L (ft) | | Vent and Connector Diameter - D (inches) | | | | | | | | | | | | | | | | | | | | | | | |
|---------------------|-----|----------------------|------|---|-----|------|------|-----|------|------|-----|------|------|-----|-------|------|-----|-------|------|-----|-------|------|-----|-------|-------|-----|-----|
| | | | | 10" | | | 12" | | | 14" | | | 16" | | | 18" | | | 20" | | | 22" | | | 24" | | |
| | | | | Appliance Input Rating in Thousands of Btu Per Hour | | | | | | | | | | | | | | | | | | | | | | | |
| | | | | FAN | | NAT | FAN | | NAT | FAN | | NAT | FAN | | NAT | FAN | | NAT | FAN | | NAT | FAN | | NAT | FAN | | NAT |
| Min | Max | Max | Min | Max | Max | Min | Max | Max | Min | Max | Max | Min | Max | Max | Min | Max | Max | Min | Max | Max | Min | Max | Max | Min | Max | Max | |
| 6 | 0 | 0 | 1121 | 570 | 0 | 1645 | 850 | 0 | 2267 | 1170 | 0 | 2983 | 1530 | 0 | 3802 | 1960 | 0 | 4721 | 2430 | 0 | 5737 | 2950 | 0 | 6853 | 3520 | | |
| | 2 | 75 | 675 | 455 | 103 | 982 | 650 | 138 | 1346 | 890 | 178 | 1769 | 1170 | 225 | 2250 | 1480 | 296 | 2782 | 1850 | 360 | 3377 | 2220 | 426 | 4030 | 2670 | | |
| | 4 | 110 | 668 | 445 | 147 | 975 | 640 | 191 | 1338 | 880 | 242 | 1761 | 1160 | 300 | 2242 | 1475 | 390 | 2774 | 1835 | 469 | 3370 | 2215 | 555 | 4023 | 2660 | | |
| 8 | 0 | 0 | 1261 | 660 | 0 | 1858 | 970 | 0 | 2571 | 1320 | 0 | 3399 | 1740 | 0 | 4333 | 2220 | 0 | 5387 | 2750 | 0 | 6555 | 3360 | 0 | 7838 | 4010 | | |
| | 2 | 71 | 770 | 515 | 98 | 1124 | 745 | 130 | 1543 | 1020 | 168 | 2030 | 1340 | 212 | 2584 | 1700 | 278 | 3196 | 2110 | 336 | 3882 | 2560 | 401 | 4634 | 3050 | | |
| | 5 | 115 | 758 | 503 | 147 | 1110 | 733 | 199 | 1528 | 1010 | 251 | 2013 | 1330 | 311 | 2563 | 1685 | 398 | 3180 | 2090 | 476 | 3863 | 2545 | 562 | 4612 | 3040 | | |
| 10 | 0 | 0 | 1377 | 720 | 0 | 2036 | 1060 | 0 | 2825 | 1450 | 0 | 3742 | 1925 | 0 | 4782 | 2450 | 0 | 5955 | 3050 | 0 | 7254 | 3710 | 0 | 8682 | 4450 | | |
| | 2 | 68 | 852 | 560 | 93 | 1244 | 850 | 124 | 1713 | 1130 | 161 | 2256 | 1480 | 202 | 2868 | 1890 | 264 | 3556 | 2340 | 319 | 4322 | 2840 | 378 | 5153 | 3390 | | |
| | 5 | 112 | 839 | 547 | 149 | 1229 | 829 | 192 | 1696 | 1105 | 243 | 2238 | 1461 | 300 | 2849 | 1871 | 382 | 3536 | 2318 | 458 | 4301 | 2818 | 540 | 5132 | 3371 | | |
| 15 | 0 | 0 | 1596 | 840 | 0 | 2380 | 1240 | 0 | 3323 | 1720 | 0 | 4423 | 2270 | 0 | 5678 | 2900 | 0 | 7099 | 3620 | 0 | 8665 | 4410 | 0 | 10393 | 5300 | | |
| | 2 | 63 | 1019 | 675 | 86 | 1495 | 985 | 114 | 2062 | 1350 | 147 | 2719 | 1770 | 186 | 3467 | 2260 | 239 | 4304 | 2800 | 290 | 5232 | 3410 | 346 | 6251 | 4080 | | |
| | 5 | 105 | 1003 | 660 | 140 | 1476 | 967 | 182 | 2041 | 1327 | 229 | 2696 | 1748 | 283 | 3442 | 2235 | 355 | 4278 | 2777 | 426 | 5204 | 3385 | 501 | 6222 | 4057 | | |
| 20 | 0 | 0 | 1756 | 930 | 0 | 2637 | 1350 | 0 | 3701 | 1900 | 0 | 4948 | 2520 | 0 | 6376 | 3250 | 0 | 7988 | 4060 | 0 | 9785 | 4980 | 0 | 11753 | 6000 | | |
| | 2 | 59 | 1150 | 755 | 81 | 1694 | 1100 | 107 | 2343 | 1520 | 139 | 3097 | 2000 | 175 | 3955 | 2570 | 220 | 4916 | 3200 | 269 | 5983 | 3910 | 321 | 7154 | 4700 | | |
| | 5 | 101 | 1133 | 738 | 135 | 1674 | 1079 | 174 | 2320 | 1498 | 219 | 3071 | 1978 | 270 | 3926 | 2544 | 337 | 4885 | 3174 | 403 | 5950 | 3880 | 475 | 7119 | 4662 | | |
| 30 | 0 | 0 | 1977 | 1060 | 0 | 3004 | 1550 | 0 | 4252 | 2170 | 0 | 5725 | 2920 | 0 | 7420 | 3770 | 0 | 9341 | 4750 | 0 | 11483 | 5850 | 0 | 13848 | 7060 | | |
| | 2 | 54 | 1351 | 865 | 74 | 2004 | 1310 | 98 | 2786 | 1800 | 127 | 3696 | 2380 | 159 | 4734 | 3050 | 199 | 5900 | 3810 | 241 | 7194 | 4650 | 285 | 8617 | 5600 | | |
| | 5 | 96 | 1332 | 851 | 127 | 1981 | 1289 | 164 | 2759 | 1775 | 206 | 3666 | 2350 | 252 | 4701 | 3020 | 312 | 5863 | 3783 | 373 | 7155 | 4622 | 439 | 8574 | 5552 | | |
| 50 | 0 | 0 | 2231 | 1195 | 0 | 3441 | 1825 | 0 | 4934 | 2550 | 0 | 6711 | 3440 | 0 | 8774 | 4460 | 0 | 11129 | 5635 | 0 | 13767 | 6940 | 0 | 16694 | 8430 | | |
| | 2 | 41 | 1620 | 1010 | 66 | 2431 | 1513 | 86 | 3409 | 2125 | 113 | 4554 | 2840 | 141 | 5864 | 3670 | 171 | 7339 | 4630 | 209 | 8980 | 5695 | 251 | 10788 | 6860 | | |
| | 5 | 90 | 1600 | 996 | 118 | 2406 | 1495 | 151 | 3380 | 2102 | 191 | 4520 | 2813 | 234 | 5826 | 3639 | 283 | 7295 | 4597 | 336 | 8933 | 5654 | 394 | 10737 | 6818 | | |
| 100 | 0 | 0 | 2491 | 1310 | 0 | 3925 | 2050 | 0 | 5729 | 2950 | 0 | 7914 | 4050 | 0 | 10485 | 5300 | 0 | 13454 | 6700 | 0 | 16817 | 8600 | 0 | 20578 | 10300 | | |
| | 2 | 30 | 1975 | 1170 | 44 | 3027 | 1820 | 72 | 4313 | 2550 | 95 | 5834 | 3500 | 120 | 7591 | 4600 | 138 | 9577 | 5800 | 169 | 11803 | 7200 | 204 | 14264 | 8800 | | |
| | 5 | 82 | 1955 | 1159 | 107 | 3002 | 1803 | 136 | 4282 | 2531 | 172 | 5797 | 3475 | 208 | 7548 | 4566 | 245 | 9528 | 5769 | 293 | 11748 | 7162 | 341 | 14204 | 8756 | | |

VENT TABLES

Capacity of Type B Double-Wall Vents with Single-Wall Metal Connectors
Serving a Single Category I Appliance

TABLE 2

| Height H (ft) | | Lateral L (ft) | | Vent and Connector Diameter - D (inches) | | | | | | | | | | | | | | | | | | | | | | | | | | |
|---------------------|-----|----------------------|-----|---|-----|-----|-----|-----|-----|-----|-----|-----|-----|-----|-----|-----|------|------|-----|------|------|------|------|------|------|------|------|------|------|------|
| | | | | 3" | | | 4" | | | 5" | | | 6" | | | 7" | | | 8" | | | 9" | | | 10" | | | 12" | | |
| | | | | Appliance Input Rating in Thousands of Btu Per Hour | | | | | | | | | | | | | | | | | | | | | | | | | | |
| | | | | FAN | | NAT | FAN | | NAT | FAN | | NAT | FAN | | NAT | FAN | | NAT | FAN | | NAT | FAN | | NAT | FAN | | NAT | FAN | | NAT |
| Min | Max | Max | Min | Max | Max | Min | Max | Max | Min | Max | Max | Min | Max | Max | Min | Max | Max | Min | Max | Max | Min | Max | Max | Min | Max | Max | | | | |
| 6 | 0 | 38 | 77 | 45 | 59 | 151 | 85 | 85 | 249 | 140 | 126 | 373 | 204 | 165 | 522 | 284 | 211 | 695 | 369 | 267 | 894 | 469 | 371 | 1118 | 569 | 537 | 1639 | 849 | | |
| | 2 | 39 | 51 | 36 | 60 | 96 | 66 | 85 | 156 | 104 | 123 | 231 | 156 | 159 | 320 | 213 | 201 | 423 | 284 | 251 | 541 | 368 | 347 | 673 | 453 | 498 | 979 | 648 | | |
| | 4 | NR | NR | 33 | 74 | 92 | 63 | 102 | 152 | 102 | 146 | 225 | 152 | 187 | 313 | 208 | 237 | 416 | 277 | 295 | 533 | 360 | 409 | 664 | 443 | 584 | 971 | 638 | | |
| | 6 | NR | NR | 31 | 83 | 89 | 60 | 114 | 147 | 99 | 163 | 220 | 148 | 207 | 307 | 203 | 263 | 409 | 271 | 327 | 526 | 352 | 449 | 656 | 433 | 638 | 962 | 627 | | |
| 8 | 0 | 37 | 83 | 50 | 58 | 164 | 93 | 83 | 273 | 154 | 123 | 412 | 234 | 161 | 580 | 319 | 206 | 777 | 414 | 258 | 1002 | 536 | 360 | 1257 | 658 | 521 | 1852 | 967 | | |
| | 2 | 39 | 56 | 39 | 59 | 108 | 75 | 83 | 176 | 119 | 121 | 261 | 179 | 155 | 363 | 246 | 197 | 482 | 321 | 246 | 617 | 417 | 339 | 768 | 513 | 486 | 1120 | 743 | | |
| | 5 | NR | NR | 37 | 77 | 102 | 69 | 107 | 168 | 114 | 151 | 252 | 171 | 193 | 352 | 235 | 285 | 470 | 311 | 305 | 604 | 404 | 418 | 754 | 500 | 598 | 1104 | 730 | | |
| | 8 | NR | NR | 33 | 90 | 95 | 64 | 122 | 161 | 107 | 175 | 243 | 163 | 223 | 342 | 225 | 280 | 458 | 300 | 344 | 591 | 392 | 470 | 740 | 486 | 665 | 1089 | 715 | | |
| 10 | 0 | 37 | 87 | 53 | 57 | 174 | 99 | 82 | 293 | 165 | 120 | 444 | 254 | 158 | 628 | 344 | 202 | 844 | 449 | 253 | 1093 | 584 | 351 | 1373 | 718 | 507 | 2031 | 1057 | | |
| | 2 | 39 | 61 | 41 | 59 | 117 | 80 | 82 | 193 | 128 | 119 | 287 | 194 | 153 | 400 | 272 | 193 | 531 | 354 | 242 | 681 | 456 | 332 | 849 | 559 | 475 | 1242 | 848 | | |
| | 5 | 52 | 56 | 39 | 76 | 111 | 76 | 105 | 185 | 122 | 148 | 277 | 186 | 190 | 388 | 261 | 241 | 518 | 344 | 299 | 667 | 443 | 409 | 834 | 544 | 584 | 1224 | 825 | | |
| | 10 | NR | NR | 34 | 97 | 100 | 68 | 132 | 171 | 112 | 188 | 261 | 171 | 237 | 369 | 241 | 296 | 497 | 325 | 363 | 643 | 423 | 492 | 808 | 520 | 688 | 1194 | 788 | | |
| 15 | 0 | 36 | 93 | 57 | 56 | 190 | 111 | 80 | 325 | 186 | 116 | 499 | 283 | 153 | 713 | 388 | 195 | 966 | 523 | 244 | 1259 | 681 | 336 | 1591 | 838 | 488 | 2374 | 1237 | | |
| | 2 | 38 | 69 | 47 | 57 | 136 | 93 | 80 | 225 | 149 | 115 | 337 | 224 | 148 | 473 | 314 | 187 | 631 | 413 | 232 | 812 | 543 | 319 | 1015 | 673 | 475 | 1491 | 983 | | |
| | 5 | 51 | 63 | 44 | 75 | 128 | 86 | 102 | 216 | 140 | 144 | 326 | 217 | 182 | 459 | 298 | 231 | 616 | 400 | 287 | 795 | 526 | 392 | 997 | 657 | 562 | 1469 | 963 | | |
| | 10 | NR | NR | 39 | 95 | 116 | 79 | 128 | 201 | 131 | 182 | 308 | 203 | 228 | 438 | 284 | 284 | 592 | 381 | 349 | 768 | 501 | 470 | 966 | 628 | 664 | 1433 | 928 | | |
| 15 | NR | NR | NR | NR | NR | 72 | 158 | 186 | 124 | 220 | 290 | 192 | 272 | 418 | 269 | 334 | 568 | 367 | 404 | 742 | 484 | 540 | 937 | 601 | 750 | 1399 | 894 | | | |
| 20 | 0 | 35 | 96 | 60 | 54 | 200 | 118 | 78 | 346 | 201 | 114 | 537 | 306 | 149 | 772 | 428 | 190 | 1053 | 573 | 238 | 1379 | 750 | 326 | 1751 | 927 | 473 | 2631 | 1346 | | |
| | 2 | 37 | 74 | 50 | 56 | 148 | 99 | 78 | 248 | 165 | 113 | 375 | 248 | 144 | 528 | 344 | 182 | 708 | 468 | 227 | 914 | 611 | 309 | 1146 | 754 | 443 | 1689 | 1098 | | |
| | 5 | 50 | 68 | 47 | 73 | 140 | 94 | 100 | 239 | 158 | 141 | 363 | 239 | 178 | 514 | 334 | 224 | 692 | 457 | 279 | 896 | 596 | 381 | 1126 | 734 | 547 | 1665 | 1074 | | |
| | 10 | NR | NR | 41 | 93 | 129 | 86 | 125 | 223 | 146 | 177 | 344 | 224 | 222 | 491 | 316 | 277 | 666 | 437 | 339 | 866 | 570 | 457 | 1092 | 702 | 646 | 1626 | 1037 | | |
| 15 | NR | NR | NR | NR | NR | 80 | 155 | 208 | 136 | 216 | 325 | 210 | 264 | 469 | 301 | 325 | 640 | 419 | 393 | 838 | 549 | 526 | 1060 | 677 | 730 | 1587 | 1005 | | | |
| 20 | NR | NR | NR | NR | NR | NR | 186 | 192 | 126 | 254 | 306 | 196 | 309 | 448 | 285 | 374 | 616 | 400 | 448 | 810 | 526 | 592 | 1028 | 651 | 808 | 1550 | 973 | | | |
| 30 | 0 | 34 | 99 | 63 | 53 | 211 | 127 | 76 | 372 | 219 | 110 | 584 | 334 | 144 | 849 | 472 | 184 | 1168 | 647 | 229 | 1542 | 852 | 312 | 1971 | 1056 | 454 | 2996 | 1545 | | |
| | 2 | 37 | 80 | 56 | 55 | 164 | 111 | 76 | 281 | 183 | 109 | 429 | 279 | 139 | 610 | 392 | 175 | 823 | 533 | 219 | 1069 | 698 | 296 | 1346 | 863 | 424 | 1999 | 1308 | | |
| | 5 | 49 | 74 | 52 | 72 | 157 | 106 | 98 | 271 | 173 | 136 | 417 | 271 | 171 | 595 | 382 | 215 | 806 | 521 | 269 | 1049 | 684 | 366 | 1324 | 846 | 524 | 1971 | 1283 | | |
| | 10 | NR | NR | NR | 91 | 144 | 98 | 122 | 255 | 168 | 171 | 397 | 257 | 213 | 570 | 367 | 265 | 777 | 501 | 327 | 1017 | 662 | 440 | 1287 | 821 | 620 | 1927 | 1243 | | |
| 15 | NR | NR | NR | 115 | 131 | NR | 151 | 239 | 157 | 208 | 377 | 242 | 255 | 547 | 349 | 312 | 750 | 481 | 379 | 985 | 638 | 507 | 1251 | 794 | 702 | 1884 | 1205 | | | |
| 20 | NR | NR | NR | NR | NR | NR | 181 | 223 | NR | 246 | 357 | 228 | 298 | 524 | 333 | 360 | 723 | 461 | 433 | 955 | 615 | 570 | 1216 | 768 | 780 | 1841 | 1166 | | | |
| 30 | NR | NR | NR | NR | NR | NR | NR | NR | NR | NR | NR | NR | NR | NR | NR | 389 | 477 | 305 | 461 | 670 | 426 | 541 | 895 | 574 | 704 | 1147 | 937 | 1759 | 1101 | |
| 50 | 0 | 33 | 99 | 66 | 51 | 213 | 133 | 73 | 394 | 230 | 105 | 629 | 361 | 138 | 928 | 515 | 176 | 1292 | 704 | 220 | 1724 | 948 | 295 | 2223 | 1189 | 428 | 3432 | 1818 | | |
| | 2 | 36 | 84 | 61 | 53 | 181 | 121 | 73 | 318 | 205 | 104 | 495 | 312 | 133 | 712 | 443 | 168 | 971 | 613 | 209 | 1273 | 811 | 280 | 1615 | 1007 | 401 | 2426 | 1509 | | |
| | 5 | 48 | 80 | NR | 70 | 174 | 117 | 94 | 308 | 198 | 131 | 482 | 305 | 164 | 696 | 435 | 204 | 953 | 602 | 257 | 1252 | 795 | 347 | 1591 | 991 | 496 | 2396 | 1490 | | |
| | 10 | NR | NR | NR | 89 | 160 | NR | 118 | 292 | 186 | 162 | 461 | 292 | 203 | 671 | 420 | 253 | 923 | 583 | 313 | 1217 | 765 | 418 | 1551 | 963 | 589 | 2347 | 1455 | | |
| 15 | NR | NR | NR | 112 | 148 | NR | 145 | 275 | 174 | 199 | 441 | 280 | 244 | 646 | 405 | 299 | 894 | 562 | 363 | 1183 | 736 | 481 | 1512 | 934 | 668 | 2299 | 1421 | | | |
| 20 | NR | NR | NR | NR | NR | NR | 176 | 257 | NR | 236 | 420 | 267 | 285 | 622 | 389 | 345 | 866 | 543 | 415 | 1150 | 708 | 544 | 1473 | 906 | 741 | 2251 | 1387 | | | |
| 30 | NR | NR | NR | NR | NR | NR | NR | NR | NR | 315 | 376 | NR | 373 | 573 | NR | 442 | 809 | 502 | 521 | 1086 | 649 | 674 | 1399 | 848 | 892 | 2159 | 1318 | | | |
| 100 | 0 | NR | NR | NR | 49 | 214 | NR | 69 | 403 | NR | 100 | 659 | 395 | 131 | 991 | 555 | 166 | 1404 | 765 | 207 | 1900 | 1033 | 273 | 2479 | 1300 | 395 | 3912 | 2042 | | |
| | 2 | NR | NR | NR | 51 | 192 | NR | 70 | 351 | NR | 98 | 563 | 373 | 125 | 828 | 508 | 158 | 1152 | 698 | 196 | 1532 | 933 | 259 | 1970 | 1168 | 371 | 3021 | 1817 | | |
| | 5 | NR | NR | NR | 67 | 186 | NR | 90 | 342 | NR | 125 | 551 | 366 | 156 | 813 | 501 | 194 | 1134 | 688 | 240 | 1511 | 921 | 322 | 1945 | 1153 | 460 | 2990 | 1796 | | |
| | 10 | NR | NR | NR | 85 | 175 | NR | 113 | 324 | NR | 153 | 532 | 354 | 191 | 789 | 486 | 238 | 1104 | 672 | 293 | 1477 | 902 | 389 | 1905 | 1133 | 547 | 2938 | 1763 | | |
| 15 | NR | NR | NR | 132 | 162 | NR | 138 | 310 | NR | 188 | 511 | 343 | 230 | 764 | 473 | 281 | 1075 | 656 | 342 | 1443 | 884 | 447 | 1865 | 1110 | 618 | 2888 | 1730 | | | |
| 20 | NR | NR | NR | NR | NR | NR | 168 | 295 | NR | 224 | 487 | NR | 270 | 739 | 458 | 325 | 1046 | 639 | 391 | 1410 | 864 | 507 | 1825 | 1087 | 690 | 2838 | 1696 | | | |
| 30 | NR | NR | NR | NR | NR | NR | 231 | 264 | NR | 301 | 448 | NR | 355 | 685 | NR | 418 | 988 | NR | 491 | 1343 | 824 | 631 | 1747 | 1041 | 834 | 2739 | 1627 | | | |
| 50 | NR | NR | NR | NR | NR | NR | NR | NR | NR | NR | NR | NR | NR | NR | NR | 540 | 584 | NR | 617 | 866 | NR | 711 | 1205 | NR | 895 | 1591 | NR | 1138 | 2547 | 1489 |

VENT TABLES

Capacity of Type B Double-Wall Vents with Type B Double-Wall Connectors
Serving Two or more Category I Appliances

TABLE 3

Vent Connector Capacity

| Vent Height H (ft) | Connector Rise R (ft) | Vent Connector Diameter - D (inches) | | | | | | | | | | | | | | | | | | | | | | | |
|--------------------|-----------------------|--|-----|-----|-----|-----|-----|-----|-----|-----|-----|-----|-----|-----|-----|-----|-----|-----|-----|-----|------|-----|-----|------|-----|
| | | 3" | | 4" | | | 5" | | | 6" | | | 7" | | | 8" | | | 9" | | | 10" | | | |
| | | Appliance Input Rating Limits in Thousands of Btu Per Hour | | | | | | | | | | | | | | | | | | | | | | | |
| | | FAN | | NAT | FAN | | NAT | FAN | | NAT | FAN | | NAT | FAN | | NAT | FAN | | NAT | FAN | | NAT | FAN | | NAT |
| Min | Max | Max | Min | Max | Max | Min | Max | Max | Min | Max | Max | Min | Max | Max | Min | Max | Max | Min | Max | Max | Min | Max | Max | | |
| 6 | 1 | 22 | 37 | 26 | 35 | 66 | 46 | 46 | 106 | 72 | 58 | 164 | 104 | 77 | 225 | 142 | 92 | 296 | 185 | 109 | 376 | 237 | 128 | 466 | 289 |
| | 2 | 23 | 41 | 31 | 37 | 75 | 55 | 48 | 121 | 86 | 60 | 183 | 124 | 79 | 253 | 168 | 95 | 333 | 220 | 112 | 424 | 282 | 131 | 526 | 345 |
| | 3 | 24 | 44 | 35 | 38 | 81 | 62 | 49 | 132 | 96 | 62 | 199 | 139 | 82 | 275 | 189 | 97 | 363 | 248 | 114 | 463 | 317 | 134 | 575 | 386 |
| 8 | 1 | 22 | 40 | 27 | 35 | 72 | 48 | 49 | 114 | 76 | 64 | 176 | 109 | 84 | 243 | 148 | 100 | 320 | 194 | 118 | 408 | 248 | 138 | 507 | 303 |
| | 2 | 23 | 44 | 32 | 36 | 80 | 57 | 51 | 128 | 90 | 66 | 195 | 129 | 86 | 269 | 175 | 103 | 356 | 230 | 121 | 454 | 294 | 141 | 564 | 358 |
| | 3 | 24 | 47 | 36 | 37 | 87 | 64 | 53 | 139 | 101 | 67 | 210 | 145 | 88 | 290 | 198 | 105 | 384 | 258 | 123 | 492 | 330 | 143 | 612 | 402 |
| 10 | 1 | 22 | 43 | 28 | 34 | 78 | 50 | 49 | 123 | 78 | 65 | 189 | 113 | 89 | 257 | 154 | 106 | 341 | 200 | 125 | 436 | 257 | 146 | 542 | 314 |
| | 2 | 23 | 47 | 33 | 36 | 86 | 59 | 51 | 136 | 93 | 67 | 206 | 134 | 91 | 282 | 182 | 109 | 374 | 238 | 128 | 479 | 305 | 149 | 596 | 372 |
| | 3 | 24 | 50 | 37 | 37 | 92 | 67 | 52 | 146 | 104 | 69 | 220 | 150 | 94 | 303 | 205 | 111 | 402 | 268 | 131 | 515 | 342 | 152 | 642 | 417 |
| 15 | 1 | 21 | 50 | 30 | 33 | 89 | 53 | 47 | 142 | 83 | 64 | 220 | 120 | 88 | 298 | 163 | 110 | 389 | 214 | 134 | 493 | 273 | 162 | 609 | 333 |
| | 2 | 22 | 53 | 35 | 35 | 96 | 63 | 49 | 153 | 99 | 66 | 235 | 142 | 91 | 320 | 193 | 112 | 419 | 253 | 137 | 532 | 323 | 165 | 658 | 394 |
| | 3 | 24 | 55 | 40 | 36 | 102 | 71 | 51 | 163 | 111 | 68 | 248 | 160 | 93 | 339 | 218 | 115 | 445 | 286 | 140 | 565 | 365 | 167 | 700 | 444 |
| 20 | 1 | 21 | 54 | 31 | 33 | 99 | 56 | 46 | 157 | 87 | 62 | 246 | 125 | 86 | 334 | 171 | 107 | 436 | 224 | 131 | 552 | 285 | 158 | 681 | 347 |
| | 2 | 22 | 57 | 37 | 34 | 105 | 66 | 48 | 167 | 104 | 64 | 259 | 149 | 89 | 354 | 202 | 110 | 463 | 265 | 134 | 587 | 339 | 161 | 725 | 414 |
| | 3 | 23 | 60 | 42 | 35 | 110 | 74 | 50 | 176 | 116 | 66 | 271 | 168 | 91 | 371 | 228 | 113 | 486 | 300 | 137 | 618 | 358 | 164 | 764 | 466 |
| 30 | 1 | 20 | 62 | 33 | 31 | 113 | 59 | 45 | 181 | 93 | 60 | 288 | 134 | 83 | 391 | 182 | 103 | 512 | 238 | 125 | 649 | 305 | 151 | 802 | 372 |
| | 2 | 21 | 64 | 39 | 33 | 118 | 70 | 47 | 190 | 110 | 62 | 299 | 158 | 85 | 408 | 215 | 105 | 535 | 282 | 129 | 679 | 360 | 155 | 840 | 439 |
| | 3 | 22 | 66 | 44 | 34 | 123 | 79 | 48 | 198 | 124 | 64 | 309 | 178 | 88 | 423 | 242 | 108 | 555 | 317 | 132 | 706 | 405 | 158 | 874 | 494 |
| 50 | 1 | 19 | 71 | 36 | 30 | 133 | 64 | 43 | 216 | 101 | 57 | 349 | 145 | 78 | 477 | 197 | 97 | 627 | 257 | 120 | 797 | 330 | 144 | 984 | 403 |
| | 2 | 21 | 73 | 43 | 32 | 137 | 76 | 45 | 223 | 119 | 59 | 358 | 172 | 81 | 490 | 234 | 100 | 645 | 306 | 123 | 820 | 392 | 148 | 1014 | 478 |
| | 3 | 22 | 75 | 48 | 33 | 141 | 86 | 46 | 229 | 134 | 61 | 366 | 194 | 83 | 502 | 263 | 103 | 661 | 343 | 126 | 842 | 441 | 151 | 1043 | 538 |
| 100 | 1 | 18 | 82 | 37 | 28 | 158 | 66 | 40 | 262 | 104 | 53 | 442 | 150 | 73 | 611 | 204 | 91 | 810 | 266 | 112 | 1038 | 341 | 135 | 1285 | 417 |
| | 2 | 19 | 83 | 44 | 30 | 161 | 79 | 42 | 267 | 123 | 55 | 447 | 178 | 75 | 619 | 242 | 94 | 822 | 316 | 115 | 1054 | 405 | 139 | 1306 | 494 |
| | 3 | 20 | 84 | 50 | 31 | 163 | 89 | 44 | 272 | 138 | 57 | 452 | 200 | 78 | 627 | 272 | 97 | 834 | 355 | 118 | 1069 | 455 | 142 | 1327 | 555 |

Common Vent Capacity

| Vent Height H (ft) | Common Vent Diameter - D (inches) | | | | | | | | | | | | | | | | | | | | |
|--------------------|--|----------|----------|----------|----------|----------|----------|----------|----------|----------|----------|----------|----------|----------|----------|----------|----------|----------|----------|----------|----------|
| | 4" | | | 5" | | | 6" | | | 7" | | | 8" | | | 9" | | | 10" | | |
| | Combined Appliance Input Rating in Thousands of Btu Per Hour | | | | | | | | | | | | | | | | | | | | |
| | FAN +FAN | FAN +NAT | NAT +NAT | FAN +FAN | FAN +NAT | NAT +NAT | FAN +FAN | FAN +NAT | NAT +NAT | FAN +FAN | FAN +NAT | NAT +NAT | FAN +FAN | FAN +NAT | NAT +NAT | FAN +FAN | FAN +NAT | NAT +NAT | FAN +FAN | FAN +NAT | NAT +NAT |
| 6 | 92 | 81 | 65 | 140 | 116 | 103 | 204 | 161 | 147 | 309 | 248 | 200 | 404 | 314 | 260 | 547 | 434 | 335 | 672 | 520 | 410 |
| 8 | 101 | 90 | 73 | 155 | 129 | 114 | 224 | 178 | 163 | 339 | 275 | 223 | 444 | 348 | 290 | 602 | 480 | 378 | 740 | 577 | 465 |
| 10 | 110 | 97 | 79 | 169 | 141 | 124 | 243 | 194 | 178 | 367 | 299 | 242 | 477 | 377 | 315 | 649 | 522 | 405 | 800 | 627 | 495 |
| 15 | 125 | 112 | 91 | 195 | 164 | 144 | 283 | 228 | 206 | 427 | 352 | 280 | 556 | 444 | 365 | 753 | 612 | 465 | 924 | 733 | 565 |
| 20 | 136 | 123 | 102 | 215 | 183 | 160 | 314 | 255 | 229 | 475 | 394 | 310 | 621 | 499 | 405 | 842 | 688 | 523 | 1035 | 826 | 640 |
| 30 | 152 | 138 | 118 | 244 | 210 | 185 | 361 | 297 | 266 | 547 | 459 | 360 | 720 | 585 | 470 | 979 | 808 | 605 | 1209 | 975 | 740 |
| 50 | 167 | 153 | 134 | 279 | 244 | 214 | 421 | 353 | 310 | 641 | 547 | 423 | 854 | 706 | 550 | 1164 | 977 | 705 | 1451 | 1188 | 860 |
| 100 | 175 | 163 | NR | 311 | 277 | NR | 489 | 421 | NR | 751 | 658 | 479 | 1025 | 873 | 625 | 1408 | 1215 | 800 | 1784 | 1502 | 975 |

VENT TABLES

Capacity of Type B Double-Wall Vents with Type B Double-Wall Connectors Serving two or more Category I Appliances

TABLE 3 (cont'd)

Vent Connector Capacity

| Vent Connector Height H (ft) Rise R (ft) | | Vent Connector Diameter - D (inches) | | | | | | | | | | | | | | | | | | | | | |
|---|-----|--|------|------|-----|------|------|-----|------|------|-----|------|------|-----|------|------|-----|------|------|-----|------|------|-----|
| | | 12" | | | 14" | | | 16" | | | 18" | | | 20" | | | 22" | | | 24" | | | |
| | | Appliance Input Rating Limits in Thousands of Btu Per Hour | | | | | | | | | | | | | | | | | | | | | |
| | | FAN | | | NAT | | | FAN | | | NAT | | | FAN | | | NAT | | | FAN | | | NAT |
| Min | Max | Max | Min | Max | Max | Min | Max | Max | Min | Max | Max | Min | Max | Max | Min | Max | Max | Min | Max | Max | Min | Max | Max |
| 6 | 2 | 174 | 764 | 496 | 223 | 1046 | 653 | 281 | 1371 | 853 | 346 | 1772 | 1080 | NA | NA | NA | NA | NA | NA | NA | NA | NA | NA |
| | 4 | 180 | 897 | 616 | 230 | 1231 | 827 | 287 | 1617 | 1081 | 352 | 2069 | 1370 | NA | NA | NA | NA | NA | NA | NA | NA | NA | NA |
| | 6 | NA | NA | NA | NA | NA | NA | NA | NA | NA | NA | NA | NA | NA | NA | NA | NA | NA | NA | NA | NA | NA | NA |
| 8 | 2 | 186 | 822 | 516 | 238 | 1126 | 696 | 298 | 1478 | 910 | 365 | 1920 | 1150 | NA | NA | NA | NA | NA | NA | NA | NA | NA | NA |
| | 4 | 192 | 952 | 644 | 244 | 1307 | 884 | 305 | 1719 | 1150 | 372 | 2211 | 1460 | 471 | 2737 | 1800 | 560 | 3319 | 2180 | 662 | 3957 | 2590 | |
| | 6 | 198 | 1050 | 772 | 252 | 1445 | 1072 | 313 | 1902 | 1390 | 380 | 2434 | 1770 | 478 | 3018 | 2180 | 568 | 3665 | 2640 | 669 | 4373 | 3130 | |
| 10 | 2 | 196 | 870 | 536 | 249 | 1195 | 730 | 311 | 1570 | 955 | 379 | 2049 | 1205 | NA | NA | NA | NA | NA | NA | NA | NA | NA | NA |
| | 4 | 201 | 997 | 664 | 256 | 1371 | 924 | 318 | 1804 | 1205 | 387 | 2332 | 1535 | 486 | 2887 | 1890 | 581 | 3502 | 2280 | 686 | 4175 | 2710 | |
| | 6 | 207 | 1095 | 792 | 263 | 1509 | 1118 | 325 | 1989 | 1455 | 395 | 2556 | 1865 | 494 | 3169 | 2290 | 589 | 3849 | 2760 | 694 | 4593 | 3270 | |
| 15 | 2 | 214 | 967 | 568 | 272 | 1334 | 790 | 336 | 1760 | 1030 | 408 | 2317 | 1305 | NA | NA | NA | NA | NA | NA | NA | NA | NA | NA |
| | 4 | 221 | 1085 | 712 | 279 | 1499 | 1006 | 344 | 1978 | 1320 | 416 | 2579 | 1665 | 523 | 3197 | 2060 | 624 | 3881 | 2490 | 734 | 4631 | 2960 | |
| | 6 | 228 | 1181 | 856 | 286 | 1632 | 1222 | 351 | 2157 | 1610 | 424 | 2796 | 2025 | 533 | 3470 | 2510 | 634 | 4216 | 3030 | 743 | 5035 | 3600 | |
| 20 | 2 | 223 | 1051 | 596 | 291 | 1443 | 840 | 357 | 1911 | 1095 | 430 | 2533 | 1385 | NA | NA | NA | NA | NA | NA | NA | NA | NA | NA |
| | 4 | 230 | 1162 | 748 | 298 | 1597 | 1064 | 365 | 2116 | 1395 | 438 | 2778 | 1765 | 554 | 3447 | 2180 | 661 | 4190 | 2630 | 772 | 5005 | 3130 | |
| | 6 | 237 | 1253 | 900 | 307 | 1726 | 1288 | 373 | 2287 | 1695 | 450 | 2984 | 2145 | 567 | 3708 | 2650 | 671 | 4511 | 3190 | 785 | 5392 | 3790 | |
| 30 | 2 | 216 | 1217 | 632 | 286 | 1664 | 910 | 367 | 2183 | 1190 | 461 | 2891 | 1540 | NA | NA | NA | NA | NA | NA | NA | NA | NA | NA |
| | 4 | 223 | 1316 | 792 | 294 | 1802 | 1160 | 376 | 2366 | 1510 | 474 | 3110 | 1920 | 619 | 3840 | 2365 | 728 | 4681 | 2860 | 847 | 5606 | 3410 | |
| | 6 | 231 | 1400 | 952 | 303 | 1920 | 1410 | 384 | 2524 | 1830 | 485 | 3299 | 2340 | 632 | 4080 | 2875 | 741 | 4976 | 3480 | 860 | 5961 | 4150 | |
| 50 | 2 | 206 | 1479 | 689 | 273 | 2023 | 1007 | 350 | 2659 | 1315 | 435 | 3548 | 1665 | NA | NA | NA | NA | NA | NA | NA | NA | NA | NA |
| | 4 | 213 | 1561 | 860 | 281 | 2139 | 1291 | 359 | 2814 | 1685 | 447 | 3730 | 2135 | 580 | 4601 | 2633 | 709 | 5569 | 3185 | 851 | 6633 | 3790 | |
| | 6 | 221 | 1631 | 1031 | 290 | 2242 | 1575 | 369 | 2951 | 2055 | 461 | 3893 | 2605 | 594 | 4808 | 3208 | 724 | 5826 | 3885 | 867 | 6943 | 4620 | |
| 100 | 2 | 192 | 1923 | 712 | 254 | 2644 | 1050 | 326 | 3490 | 1370 | 402 | 4707 | 1740 | NA | NA | NA | NA | NA | NA | NA | NA | NA | NA |
| | 4 | 200 | 1984 | 888 | 263 | 2731 | 1346 | 336 | 3606 | 1760 | 414 | 4842 | 2220 | 523 | 5982 | 2750 | 639 | 7254 | 3330 | 769 | 8650 | 3950 | |
| | 6 | 208 | 2035 | 1064 | 272 | 2811 | 1642 | 346 | 3714 | 2150 | 426 | 4968 | 2700 | 539 | 6143 | 3350 | 654 | 7453 | 4070 | 786 | 8892 | 4810 | |

Common Vent Capacity

| Vent Height H (ft) | | Common Vent Diameter - D (inches) | | | | | | | | | | | | | | | | | | | | |
|-----------------------|------|--|----------|----------|----------|----------|----------|----------|----------|----------|----------|----------|----------|----------|----------|----------|----------|----------|----------|----------|----------|----------|
| | | 12" | | | 14" | | | 16" | | | 18" | | | 20" | | | 22" | | | 24" | | |
| | | Combined Appliance Input Rating in Thousands of Btu Per Hour | | | | | | | | | | | | | | | | | | | | |
| | | FAN +FAN | FAN +NAT | NAT +NAT | FAN +FAN | FAN +NAT | NAT +NAT | FAN +FAN | FAN +NAT | NAT +NAT | FAN +FAN | FAN +NAT | NAT +NAT | FAN +FAN | FAN +NAT | NAT +NAT | FAN +FAN | FAN +NAT | NAT +NAT | FAN +FAN | FAN +NAT | NAT +NAT |
| 6 | 900 | 696 | 588 | 1284 | 990 | 815 | 1735 | 1336 | 1065 | 2253 | 1732 | 1345 | 2838 | 2180 | 1660 | 3488 | 2677 | 1970 | 4206 | 3226 | 2390 | |
| 8 | 994 | 773 | 652 | 1423 | 1103 | 912 | 1927 | 1491 | 1190 | 2507 | 1936 | 1510 | 3162 | 2439 | 1860 | 3890 | 2998 | 2200 | 4695 | 3616 | 2680 | |
| 10 | 1076 | 841 | 712 | 1542 | 1200 | 995 | 2093 | 1625 | 1300 | 2727 | 2113 | 1645 | 3444 | 2665 | 2030 | 4241 | 3278 | 2400 | 5123 | 3957 | 2920 | |
| 15 | 1247 | 986 | 825 | 1794 | 1410 | 1158 | 2440 | 1910 | 1510 | 3184 | 2484 | 1910 | 4026 | 3133 | 2360 | 4971 | 3862 | 2790 | 6016 | 4670 | 3400 | |
| 20 | 1405 | 1116 | 916 | 2006 | 1588 | 1290 | 2722 | 2147 | 1690 | 3561 | 2798 | 2140 | 4548 | 3552 | 2640 | 5573 | 4352 | 3120 | 6749 | 5261 | 3800 | |
| 30 | 1658 | 1327 | 1025 | 2373 | 1892 | 1525 | 3220 | 2558 | 1990 | 4197 | 3326 | 2520 | 5303 | 4193 | 3110 | 6539 | 5157 | 3680 | 7940 | 6247 | 4480 | |
| 50 | 2024 | 1640 | 1280 | 2911 | 2347 | 1863 | 3964 | 3183 | 2430 | 5184 | 4149 | 3075 | 6567 | 5240 | 3800 | 8116 | 6458 | 4500 | 9837 | 7813 | 5475 | |
| 100 | 2569 | 2131 | 1670 | 3732 | 3076 | 2450 | 5125 | 4202 | 3200 | 6749 | 5509 | 4050 | 8597 | 6986 | 5000 | 10681 | 8648 | 5920 | 13004 | 10499 | 7200 | |

VENT TABLES

Capacity of Type B Double-Wall Vent with Single-Wall Connectors Serving Two or more Category I Appliances

TABLE 4

Vent Connector Capacity

| Vent Height H (ft) | Connector Rise R (ft) | Vent Connector Diameter - D (inches) | | | | | | | | | | | | | | | | | | | | | | | | | | | |
|--------------------|-----------------------|--|-----|-----|-----|-----|-----|-----|-----|-----|-----|-----|-----|-----|-----|-----|-----|-----|-----|-----|-----|-----|-----|------|-----|-----|-----|-----|-----|
| | | 3" | | | 4" | | | 5" | | | 6" | | | 7" | | | 8" | | | 9" | | | 10" | | | | | | |
| | | Appliance Input Rating Limits in Thousands of Btu Per Hour | | | | | | | | | | | | | | | | | | | | | | | | | | | |
| | | FAN | | | NAT | | | FAN | | | NAT | | | FAN | | | NAT | | | FAN | | | NAT | | | FAN | | | NAT |
| Min | Max | Max | Min | Max | Max | Min | Max | Max | Min | Max | Max | Min | Max | Max | Min | Max | Max | Min | Max | Max | Min | Max | Max | Min | Max | Max | Min | Max | Max |
| 6 | 1 | NR | NR | 26 | NR | NR | 46 | NR | NR | 71 | NR | NR | 102 | 207 | 223 | 140 | 262 | 293 | 183 | 325 | 373 | 234 | 447 | 463 | 286 | | | | |
| | 2 | NR | NR | 31 | NR | NR | 55 | NR | NR | 85 | 168 | 182 | 123 | 215 | 251 | 167 | 271 | 331 | 219 | 334 | 422 | 281 | 458 | 524 | 344 | | | | |
| | 3 | NR | NR | 34 | NR | NR | 62 | 121 | 131 | 95 | 174 | 198 | 138 | 222 | 273 | 188 | 279 | 361 | 247 | 344 | 462 | 316 | 468 | 574 | 385 | | | | |
| 15 | 1 | NR | NR | 29 | 79 | 87 | 52 | 116 | 138 | 81 | 177 | 214 | 116 | 238 | 291 | 158 | 312 | 380 | 208 | 397 | 482 | 266 | 556 | 596 | 324 | | | | |
| | 2 | NR | NR | 34 | 83 | 94 | 62 | 121 | 150 | 97 | 185 | 230 | 138 | 246 | 314 | 189 | 321 | 411 | 248 | 407 | 522 | 317 | 568 | 646 | 387 | | | | |
| | 3 | NR | NR | 39 | 87 | 100 | 70 | 127 | 160 | 109 | 193 | 243 | 157 | 255 | 333 | 215 | 331 | 438 | 281 | 418 | 557 | 360 | 579 | 690 | 437 | | | | |
| 30 | 1 | 47 | 60 | 31 | 77 | 110 | 57 | 113 | 175 | 89 | 169 | 278 | 129 | 226 | 380 | 175 | 296 | 497 | 230 | 378 | 630 | 294 | 528 | 779 | 358 | | | | |
| | 2 | 50 | 62 | 37 | 81 | 115 | 67 | 117 | 185 | 106 | 177 | 290 | 152 | 236 | 397 | 208 | 307 | 521 | 274 | 389 | 662 | 349 | 541 | 819 | 425 | | | | |
| | 3 | 54 | 64 | 42 | 85 | 119 | 76 | 122 | 193 | 120 | 185 | 300 | 172 | 244 | 412 | 235 | 316 | 542 | 309 | 400 | 690 | 394 | 555 | 855 | 482 | | | | |
| 50 | 1 | 46 | 69 | 33 | 75 | 128 | 60 | 109 | 207 | 96 | 162 | 336 | 137 | 217 | 460 | 188 | 284 | 604 | 245 | 364 | 768 | 314 | 507 | 951 | 384 | | | | |
| | 2 | 49 | 71 | 40 | 79 | 132 | 72 | 114 | 215 | 113 | 170 | 345 | 164 | 226 | 473 | 223 | 294 | 623 | 293 | 376 | 793 | 375 | 520 | 983 | 458 | | | | |
| | 3 | 53 | 72 | 45 | 83 | 136 | 82 | 119 | 221 | 128 | 178 | 353 | 186 | 235 | 486 | 252 | 304 | 640 | 331 | 387 | 816 | 424 | 535 | 1013 | 518 | | | | |

Common Vent Capacity

| Vent Height H (ft) | Common Vent Diameter - D (inches) | | | | | | | | | | | | | | | | | | | | |
|--------------------|--|----------|----------|----------|----------|----------|----------|----------|----------|----------|----------|----------|----------|----------|----------|----------|----------|----------|----------|----------|----------|
| | 4" | | | 5" | | | 6" | | | 7" | | | 8" | | | 9" | | | 10" | | |
| | Combined Appliance Input Rating in Thousands of Btu Per Hour | | | | | | | | | | | | | | | | | | | | |
| | FAN +FAN | FAN +NAT | NAT +NAT | FAN +FAN | FAN +NAT | NAT +NAT | FAN +FAN | FAN +NAT | NAT +NAT | FAN +FAN | FAN +NAT | NAT +NAT | FAN +FAN | FAN +NAT | NAT +NAT | FAN +FAN | FAN +NAT | NAT +NAT | FAN +FAN | FAN +NAT | NAT +NAT |
| 6 | 89 | 78 | 64 | 136 | 113 | 100 | 200 | 158 | 144 | 304 | 244 | 196 | 398 | 310 | 257 | 541 | 429 | 332 | 665 | 515 | 407 |
| 8 | 98 | 87 | 71 | 151 | 126 | 112 | 218 | 173 | 159 | 331 | 269 | 218 | 436 | 342 | 285 | 592 | 473 | 373 | 730 | 569 | 460 |
| 10 | 106 | 94 | 76 | 163 | 137 | 120 | 237 | 189 | 174 | 357 | 292 | 236 | 467 | 369 | 309 | 638 | 512 | 398 | 787 | 617 | 487 |
| 15 | 121 | 108 | 88 | 189 | 159 | 140 | 275 | 221 | 200 | 416 | 343 | 274 | 544 | 434 | 357 | 738 | 599 | 456 | 905 | 718 | 553 |
| 20 | 131 | 118 | 98 | 208 | 177 | 155 | 305 | 247 | 223 | 463 | 383 | 302 | 606 | 487 | 395 | 824 | 673 | 512 | 1013 | 808 | 626 |
| 30 | 145 | 132 | 113 | 236 | 202 | 179 | 350 | 286 | 257 | 533 | 446 | 349 | 703 | 570 | 459 | 958 | 790 | 593 | 1183 | 952 | 723 |
| 50 | 159 | 145 | 128 | 268 | 233 | 204 | 406 | 337 | 296 | 622 | 529 | 410 | 833 | 686 | 535 | 1139 | 954 | 689 | 1418 | 1157 | 838 |

VENT TABLES

Capacity of Masonry Chimney with Type B Double-Wall Vent Connectors Serving a Single Category I Appliance

| Height Lateral H L (ft) | Connector Diameter - D (inches) | | | | | | | | | | | | | | | | | | | |
|---|--|-----|-----|-----|-----|-----|-----|-----|-----|-----|-----|-----|-----|-----|-----|-----|-----|-----|-----|----|
| | To be used with chimney areas within the size limits at bottom | | | | | | | | | | | | | | | | | | | |
| | 3" | | 4" | | 5" | | 6" | | 7" | | 8" | | 9" | | 10" | | 12" | | | |
| Appliance Input Rating in Thousands of Btu Per Hour | | | | | | | | | | | | | | | | | | | | |
| FAN | | FAN | | FAN | | FAN | | FAN | | FAN | | FAN | | FAN | | FAN | | FAN | | |
| Min | Max | Min | Max | Min | Max | Min | Max | Min | Max | Min | Max | Min | Max | Min | Max | Min | Max | Min | Max | |
| NAT | | NAT | | NAT | | NAT | | NAT | | NAT | | NAT | | NAT | | NAT | | NAT | | |
| Min | Max | Min | Max | Min | Max | Min | Max | Min | Max | Min | Max | Min | Max | Min | Max | Min | Max | Min | Max | |
| 6 | 2 | NR | NR | NR | NR | NR | NR | NR | NR | NR | NR | NR | NR | NR | NR | NR | NR | NR | NR | NR |
| | 5 | NR | NR | NR | NR | NR | NR | NR | NR | NR | NR | NR | NR | NR | NR | NR | NR | NR | NR | NR |
| 10 | 2 | NR | NR | NR | NR | NR | NR | NR | NR | NR | NR | NR | NR | NR | NR | NR | NR | NR | NR | NR |
| | 5 | NR | NR | NR | NR | NR | NR | NR | NR | NR | NR | NR | NR | NR | NR | NR | NR | NR | NR | NR |
| | 10 | NR | NR | NR | NR | NR | NR | NR | NR | NR | NR | NR | NR | NR | NR | NR | NR | NR | NR | NR |
| 15 | 2 | NR | NR | NR | NR | NR | NR | NR | NR | NR | NR | NR | NR | NR | NR | NR | NR | NR | NR | NR |
| | 5 | NR | NR | NR | NR | NR | NR | NR | NR | NR | NR | NR | NR | NR | NR | NR | NR | NR | NR | NR |
| | 10 | NR | NR | NR | NR | NR | NR | NR | NR | NR | NR | NR | NR | NR | NR | NR | NR | NR | NR | NR |
| | 15 | NR | NR | NR | NR | NR | NR | NR | NR | NR | NR | NR | NR | NR | NR | NR | NR | NR | NR | NR |
| 20 | 2 | NR | NR | NR | NR | NR | NR | NR | NR | NR | NR | NR | NR | NR | NR | NR | NR | NR | NR | NR |
| | 5 | NR | NR | NR | NR | NR | NR | NR | NR | NR | NR | NR | NR | NR | NR | NR | NR | NR | NR | NR |
| | 10 | NR | NR | NR | NR | NR | NR | NR | NR | NR | NR | NR | NR | NR | NR | NR | NR | NR | NR | NR |
| | 15 | NR | NR | NR | NR | NR | NR | NR | NR | NR | NR | NR | NR | NR | NR | NR | NR | NR | NR | NR |
| | 20 | NR | NR | NR | NR | NR | NR | NR | NR | NR | NR | NR | NR | NR | NR | NR | NR | NR | NR | NR |
| 30 | 2 | NR | NR | NR | NR | NR | NR | NR | NR | NR | NR | NR | NR | NR | NR | NR | NR | NR | NR | NR |
| | 5 | NR | NR | NR | NR | NR | NR | NR | NR | NR | NR | NR | NR | NR | NR | NR | NR | NR | NR | NR |
| | 10 | NR | NR | NR | NR | NR | NR | NR | NR | NR | NR | NR | NR | NR | NR | NR | NR | NR | NR | NR |
| | 15 | NR | NR | NR | NR | NR | NR | NR | NR | NR | NR | NR | NR | NR | NR | NR | NR | NR | NR | NR |
| | 20 | NR | NR | NR | NR | NR | NR | NR | NR | NR | NR | NR | NR | NR | NR | NR | NR | NR | NR | NR |
| | 30 | NR | NR | NR | NR | NR | NR | NR | NR | NR | NR | NR | NR | NR | NR | NR | NR | NR | NR | NR |
| 50 | 2 | NR | NR | NR | NR | NR | NR | NR | NR | NR | NR | NR | NR | NR | NR | NR | NR | NR | NR | NR |
| | 5 | NR | NR | NR | NR | NR | NR | NR | NR | NR | NR | NR | NR | NR | NR | NR | NR | NR | NR | NR |
| | 10 | NR | NR | NR | NR | NR | NR | NR | NR | NR | NR | NR | NR | NR | NR | NR | NR | NR | NR | NR |
| | 15 | NR | NR | NR | NR | NR | NR | NR | NR | NR | NR | NR | NR | NR | NR | NR | NR | NR | NR | NR |
| | 20 | NR | NR | NR | NR | NR | NR | NR | NR | NR | NR | NR | NR | NR | NR | NR | NR | NR | NR | NR |
| | 30 | NR | NR | NR | NR | NR | NR | NR | NR | NR | NR | NR | NR | NR | NR | NR | NR | NR | NR | NR |
| Minimum Internal Area of Chimney Square Inches | | 12 | | 19 | | 28 | | 38 | | 50 | | 63 | | 78 | | 95 | | 132 | | |
| Maximum Internal Area of Chimney Square Inches | | 49 | | 88 | | 137 | | 198 | | 269 | | 352 | | 445 | | 550 | | 792 | | |

VENT TABLES

Capacity of Masonry Chimney with Single-Wall Vent Connectors
Serving a Single Category I Appliance

TABLE 6

| Height H (ft) | Lateral L (ft) | Connector Diameter - D (inches) | | | | | | | | | | | | | | | |
|---|----------------------|--|-----|-----|-----|-----|-----|-----|-----|-----|-----|-----|-----|-----|-----|-----|-----|
| | | To be used with chimney areas within the size limits at bottom | | | | | | | | | | | | | | | |
| | | Appliance Input Rating in Thousands of Btu Per Hour | | | | | | | | | | | | | | | |
| 3" | | 4" | | 5" | | 6" | | 7" | | 8" | | 9" | | 10" | | 12" | |
| FAN | | FAN | | FAN | | FAN | | FAN | | FAN | | FAN | | FAN | | FAN | |
| Min | Max | Min | Max | Min | Max | Min | Max | Min | Max | Min | Max | Min | Max | Min | Max | Min | Max |
| NAT | | NAT | | NAT | | NAT | | NAT | | NAT | | NAT | | NAT | | NAT | |
| Max | | Max | | Max | | Max | | Max | | Max | | Max | | Max | | Max | |
| 6 | 2 | NR | NR | NR | NR | NR | NR | NR | NR | NR | NR | NR | NR | NR | NR | NR | NR |
| | 5 | NR | NR | NR | NR | NR | NR | NR | NR | NR | NR | NR | NR | NR | NR | NR | NR |
| 10 | 2 | NR | NR | NR | NR | NR | NR | NR | NR | NR | NR | NR | NR | NR | NR | NR | NR |
| | 5 | NR | NR | NR | NR | NR | NR | NR | NR | NR | NR | NR | NR | NR | NR | NR | NR |
| | 10 | NR | NR | NR | NR | NR | NR | NR | NR | NR | NR | NR | NR | NR | NR | NR | NR |
| 15 | 2 | NR | NR | NR | NR | NR | NR | NR | NR | NR | NR | NR | NR | NR | NR | NR | NR |
| | 5 | NR | NR | NR | NR | NR | NR | NR | NR | NR | NR | NR | NR | NR | NR | NR | NR |
| | 10 | NR | NR | NR | NR | NR | NR | NR | NR | NR | NR | NR | NR | NR | NR | NR | NR |
| | 15 | NR | NR | NR | NR | NR | NR | NR | NR | NR | NR | NR | NR | NR | NR | NR | NR |
| 20 | 2 | NR | NR | NR | NR | NR | NR | NR | NR | NR | NR | NR | NR | NR | NR | NR | NR |
| | 5 | NR | NR | NR | NR | NR | NR | NR | NR | NR | NR | NR | NR | NR | NR | NR | NR |
| | 10 | NR | NR | NR | NR | NR | NR | NR | NR | NR | NR | NR | NR | NR | NR | NR | NR |
| | 15 | NR | NR | NR | NR | NR | NR | NR | NR | NR | NR | NR | NR | NR | NR | NR | NR |
| | 20 | NR | NR | NR | NR | NR | NR | NR | NR | NR | NR | NR | NR | NR | NR | NR | NR |
| 30 | 2 | NR | NR | NR | NR | NR | NR | NR | NR | NR | NR | NR | NR | NR | NR | NR | NR |
| | 5 | NR | NR | NR | NR | NR | NR | NR | NR | NR | NR | NR | NR | NR | NR | NR | NR |
| | 10 | NR | NR | NR | NR | NR | NR | NR | NR | NR | NR | NR | NR | NR | NR | NR | NR |
| | 15 | NR | NR | NR | NR | NR | NR | NR | NR | NR | NR | NR | NR | NR | NR | NR | NR |
| | 20 | NR | NR | NR | NR | NR | NR | NR | NR | NR | NR | NR | NR | NR | NR | NR | NR |
| 50 | 2 | NR | NR | NR | NR | NR | NR | NR | NR | NR | NR | NR | NR | NR | NR | NR | NR |
| | 5 | NR | NR | NR | NR | NR | NR | NR | NR | NR | NR | NR | NR | NR | NR | NR | NR |
| | 10 | NR | NR | NR | NR | NR | NR | NR | NR | NR | NR | NR | NR | NR | NR | NR | NR |
| | 15 | NR | NR | NR | NR | NR | NR | NR | NR | NR | NR | NR | NR | NR | NR | NR | NR |
| | 20 | NR | NR | NR | NR | NR | NR | NR | NR | NR | NR | NR | NR | NR | NR | NR | NR |
| | 30 | NR | NR | NR | NR | NR | NR | NR | NR | NR | NR | NR | NR | NR | NR | NR | NR |
| Minimum Internal Area of Chimney Square Inches | | 12 | | 19 | | 28 | | 38 | | 50 | | 63 | | 78 | | 95 | |
| Maximum Internal Area of Chimney Square Inches | | 49 | | 88 | | 137 | | 198 | | 269 | | 352 | | 445 | | 550 | |

* See Note 27

VENT TABLES

Capacity of Masonry Chimney with Type B Double-Wall Connectors Serving two or more Category I Appliances

TABLE 7

Vent Connector Capacity

| Vent Height H (ft) | Connector Rise R (ft) | Vent Connector Diameter - D (inches) | | | | | | | | | | | | | | | | | | | | | | | | | | | |
|--------------------|-----------------------|--|-----|-----|-----|-----|-----|-----|-----|-----|-----|-----|-----|-----|-----|-----|-----|-----|-----|-----|------|-----|-----|------|-----|-----|--|--|-----|
| | | 3" | | | 4" | | | 5" | | | 6" | | | 7" | | | 8" | | | 9" | | | 10" | | | | | | |
| | | Appliance Input Rating Limits in Thousands of Btu Per Hour | | | | | | | | | | | | | | | | | | | | | | | | | | | |
| | | FAN | | | NAT | | | FAN | | | NAT | | | FAN | | | NAT | | | FAN | | | NAT | | | FAN | | | NAT |
| Min | Max | Max | Min | Max | Max | Min | Max | Max | Min | Max | Max | Min | Max | Max | Min | Max | Max | Min | Max | Max | Min | Max | Max | Min | Max | Max | | | |
| 6 | 1 | 24 | NR | 21 | 39 | 62 | 40 | 52 | 106 | 67 | 65 | 194 | 101 | 87 | 274 | 141 | 104 | 370 | 201 | 124 | 479 | 253 | 145 | 599 | 319 | | | | |
| | 2 | 26 | 43 | 28 | 41 | 79 | 52 | 53 | 133 | 85 | 67 | 230 | 124 | 89 | 324 | 173 | 107 | 436 | 232 | 127 | 562 | 330 | 148 | 694 | 378 | | | | |
| | 3 | 27 | 49 | 34 | 42 | 92 | 61 | 55 | 155 | 97 | 69 | 262 | 143 | 91 | 369 | 203 | 109 | 491 | 270 | 129 | 633 | 349 | 151 | 795 | 439 | | | | |
| 15 | 1 | 24 | 48 | 23 | 38 | 93 | 44 | 54 | 154 | 74 | 72 | 277 | 114 | 100 | 384 | 174 | 125 | 511 | 229 | 153 | 658 | 297 | 184 | 824 | 375 | | | | |
| | 2 | 25 | 55 | 31 | 39 | 105 | 55 | 56 | 174 | 89 | 74 | 299 | 134 | 103 | 419 | 192 | 128 | 558 | 260 | 156 | 718 | 339 | 187 | 900 | 432 | | | | |
| | 3 | 26 | 59 | 35 | 41 | 115 | 64 | 57 | 189 | 102 | 76 | 319 | 153 | 105 | 448 | 215 | 131 | 597 | 292 | 159 | 760 | 382 | 190 | 960 | 486 | | | | |
| 30 | 1 | 24 | 54 | 25 | 37 | 111 | 48 | 52 | 192 | 82 | 69 | 357 | 127 | 96 | 504 | 187 | 119 | 680 | 255 | 145 | 883 | 337 | 175 | 1115 | 432 | | | | |
| | 2 | 25 | 60 | 32 | 38 | 122 | 58 | 54 | 208 | 95 | 72 | 376 | 145 | 99 | 531 | 209 | 122 | 715 | 287 | 149 | 928 | 378 | 179 | 1171 | 484 | | | | |
| | 3 | 26 | 64 | 36 | 40 | 131 | 66 | 56 | 221 | 107 | 74 | 392 | 163 | 101 | 554 | 233 | 125 | 746 | 317 | 152 | 968 | 418 | 182 | 1220 | 535 | | | | |
| 50 | 1 | 23 | 52 | 26 | 36 | 116 | 49 | 51 | 209 | 82 | 67 | 405 | 133 | 92 | 582 | 198 | 115 | 798 | 271 | 140 | 1049 | 362 | 168 | 1334 | 462 | | | | |
| | 2 | 24 | 59 | 31 | 37 | 127 | 58 | 53 | 225 | 96 | 70 | 421 | 152 | 95 | 604 | 222 | 118 | 827 | 304 | 143 | 1085 | 400 | 172 | 1379 | 510 | | | | |
| | 3 | 26 | 64 | 37 | 39 | 135 | 66 | 55 | 237 | 108 | 72 | 435 | 170 | 98 | 624 | 247 | 121 | 854 | 334 | 147 | 1118 | 439 | 176 | 1421 | 558 | | | | |

Common Vent Capacity

| Vent Height H (ft) | Minimum Internal Area of Chimney, Square Inches | | | | | | | | | | | | | | | | | | | | | | | | | | | | | | | | | | |
|--------------------|--|------|------|------|------|------|------|------|------|------|------|------|------|------|------|------|------|------|------|------|------|------|------|------|------|------|------|------|------|--|-----|--|--|-----|--|
| | 12 | | | 19 | | | 28 | | | 38 | | | 50 | | | 63 | | | 78 | | | 113 | | | | | | | | | | | | | |
| | Combined Appliance Input Rating in Thousands of Btu Per Hour | | | | | | | | | | | | | | | | | | | | | | | | | | | | | | | | | | |
| | FAN | | | FAN | | | NAT | | | FAN | | | FAN | | | NAT | | | FAN | | | FAN | | | NAT | | | FAN | | | FAN | | | NAT | |
| +FAN | +FAN | +NAT | +FAN | +FAN | +NAT | +FAN | +FAN | +NAT | +FAN | +FAN | +NAT | +FAN | +FAN | +NAT | +FAN | +FAN | +NAT | +FAN | +FAN | +NAT | +FAN | +FAN | +NAT | +FAN | +FAN | +NAT | +FAN | +FAN | +NAT | | | | | | |
| 6 | NR | 74 | 25 | NR | 119 | 46 | NR | 178 | 71 | NR | 257 | 103 | NR | 351 | 143 | NR | 458 | 188 | NR | 582 | 246 | NR | 853 | NR | | | | | | | | | | | |
| 8 | NR | 80 | 28 | NR | 130 | 53 | NR | 193 | 82 | NR | 279 | 119 | NR | 384 | 163 | NR | 501 | 218 | NR | 636 | 278 | NR | 937 | 408 | | | | | | | | | | | |
| 10 | NR | 84 | 31 | NR | 138 | 56 | NR | 207 | 90 | NR | 299 | 131 | NR | 409 | 177 | NR | 538 | 236 | NR | 686 | 302 | NR | 1010 | 454 | | | | | | | | | | | |
| 15 | NR | 90 | 36 | NR | 152 | 67 | NR | 233 | 106 | NR | 334 | 152 | NR | 467 | 212 | NR | 611 | 283 | NR | 781 | 365 | NR | 1156 | 546 | | | | | | | | | | | |
| 20 | NR | 92 | 41 | NR | 159 | 75 | NR | 250 | 122 | NR | 368 | 172 | NR | 508 | 243 | NR | 668 | 325 | NR | 858 | 419 | NR | 1286 | 648 | | | | | | | | | | | |
| 30 | NR | NR | NR | NR | NR | NR | NR | 270 | 137 | NR | 404 | 198 | NR | 564 | 278 | NR | 747 | 381 | NR | 969 | 496 | NR | 1473 | 749 | | | | | | | | | | | |
| 50 | NR | NR | NR | NR | NR | NR | NR | NR | NR | NR | NR | NR | NR | 620 | 328 | NR | 831 | 461 | NR | 1089 | 606 | NR | 1692 | 922 | | | | | | | | | | | |

VENT TABLES

Capacity of Masonry Chimney with Single-Wall Connectors Serving two or more Category I Appliances

TABLE 8

Vent Connector Capacity

| Vent Height H (ft) | Connector Rise R (ft) | Vent Connector Diameter - D (inches) | | | | | | | | | | | | | | | | | | | | | | | | | | | |
|--------------------|-----------------------|--|-----|-----|-----|-----|-----|-----|-----|-----|-----|-----|-----|-----|-----|-----|-----|-----|-----|-----|------|-----|-----|------|-----|-----|-----|-----|-----|
| | | 3" | | | 4" | | | 5" | | | 6" | | | 7" | | | 8" | | | 9" | | | 10" | | | | | | |
| | | Appliance Input Rating Limits in Thousands of Btu Per Hour | | | | | | | | | | | | | | | | | | | | | | | | | | | |
| | | FAN | | | NAT | | | FAN | | | NAT | | | FAN | | | NAT | | | FAN | | | NAT | | | FAN | | | NAT |
| Min | Max | Max | Min | Max | Max | Min | Max | Max | Min | Max | Max | Min | Max | Max | Min | Max | Max | Min | Max | Max | Min | Max | Max | Min | Max | Max | Min | Max | Max |
| 6 | 1 | NR | NR | 21 | NR | NR | 39 | NR | NR | 66 | 179 | 191 | 100 | 231 | 271 | 140 | 292 | 366 | 200 | 362 | 474 | 252 | 499 | 594 | 283 | | | | |
| | 2 | NR | NR | 28 | NR | NR | 52 | NR | NR | 84 | 186 | 227 | 123 | 239 | 321 | 172 | 301 | 432 | 231 | 373 | 557 | 299 | 509 | 696 | 331 | | | | |
| | 3 | NR | NR | 34 | NR | NR | 61 | 134 | 153 | 97 | 193 | 258 | 142 | 247 | 365 | 202 | 309 | 491 | 269 | 381 | 634 | 348 | 519 | 793 | 375 | | | | |
| 15 | 1 | NR | NR | 23 | NR | NR | 43 | 129 | 151 | 73 | 199 | 271 | 112 | 268 | 376 | 171 | 349 | 502 | 225 | 445 | 646 | 291 | 623 | 808 | 360 | | | | |
| | 2 | NR | NR | 30 | NR | NR | 54 | 135 | 170 | 88 | 207 | 295 | 132 | 277 | 411 | 189 | 359 | 548 | 256 | 456 | 706 | 334 | 634 | 884 | 402 | | | | |
| | 3 | NR | NR | 34 | NR | NR | 63 | 141 | 185 | 101 | 215 | 315 | 151 | 286 | 439 | 213 | 368 | 586 | 289 | 466 | 755 | 378 | 646 | 945 | 437 | | | | |
| 30 | 1 | NR | NR | 24 | 86 | 108 | 47 | 126 | 187 | 80 | 193 | 347 | 124 | 259 | 492 | 183 | 338 | 665 | 250 | 430 | 864 | 330 | 600 | 1089 | 455 | | | | |
| | 2 | NR | NR | 31 | 91 | 119 | 57 | 132 | 203 | 93 | 201 | 366 | 142 | 269 | 518 | 205 | 348 | 699 | 282 | 442 | 908 | 372 | 613 | 1145 | 490 | | | | |
| | 3 | NR | NR | 35 | 95 | 127 | 65 | 138 | 216 | 105 | 209 | 381 | 160 | 277 | 540 | 229 | 358 | 729 | 312 | 452 | 946 | 412 | 626 | 1193 | 521 | | | | |
| 50 | 1 | NR | NR | 25 | 85 | 113 | 48 | 124 | 204 | 80 | 188 | 392 | 130 | 252 | 567 | 194 | 328 | 778 | 265 | 417 | 1022 | 355 | 582 | 1302 | 537 | | | | |
| | 2 | NR | NR | 31 | 89 | 123 | 57 | 130 | 218 | 94 | 196 | 408 | 149 | 262 | 588 | 218 | 339 | 806 | 298 | 429 | 1058 | 393 | 596 | 1346 | 567 | | | | |
| | 3 | NR | NR | 35 | 94 | 131 | 65 | 136 | 231 | 106 | 205 | 422 | 167 | 271 | 607 | 243 | 349 | 831 | 328 | 440 | 1090 | 431 | 610 | 1386 | 595 | | | | |

Common Vent Capacity

| Vent Height H (ft) | Minimum Internal Area of Chimney, Square Inches | | | | | | | | | | | | | | | | | | | | | | | | | |
|--------------------|--|------|------|------|------|------|------|------|------|------|------|------|------|------|------|------|------|------|------|------|------|------|------|------|------|------|
| | 12 | | | 19 | | | 28 | | | 38 | | | 50 | | | 63 | | | 78 | | | 113 | | | | |
| | Combined Appliance Input Rating in Thousands of Btu Per Hour | | | | | | | | | | | | | | | | | | | | | | | | | |
| | FAN | FAN | NAT | FAN | FAN | NAT | FAN | FAN | NAT | FAN | FAN | NAT | FAN | FAN | NAT | FAN | FAN | NAT | FAN | FAN | NAT | FAN | FAN | NAT | | |
| +FAN | +NAT | +NAT | +FAN | +NAT | +NAT | +FAN | +NAT | +NAT | +FAN | +NAT | +NAT | +FAN | +NAT | +NAT | +FAN | +NAT | +NAT | +FAN | +NAT | +NAT | +FAN | +NAT | +NAT | +FAN | +NAT | +NAT |
| 6 | NR | 73 | 25 | NR | 118 | 45 | NR | 176 | 71 | NR | 255 | 102 | NR | 348 | 142 | NR | 455 | 187 | NR | 579 | 245 | NR | 846 | NR | | |
| 8 | NR | 79 | 28 | NR | 128 | 52 | NR | 190 | 81 | NR | 276 | 118 | NR | 380 | 162 | NR | 497 | 217 | NR | 633 | 277 | NR | 928 | 405 | | |
| 10 | NR | 83 | 31 | NR | 136 | 56 | NR | 205 | 89 | NR | 295 | 129 | NR | 405 | 175 | NR | 532 | 234 | NR | 680 | 300 | NR | 1000 | 450 | | |
| 15 | NR | 88 | 36 | NR | 149 | 66 | NR | 230 | 105 | NR | 335 | 150 | NR | 460 | 210 | NR | 602 | 280 | NR | 772 | 360 | NR | 1139 | 540 | | |
| 20 | NR | 90 | 40 | NR | 157 | 74 | NR | 247 | 120 | NR | 362 | 170 | NR | 503 | 240 | NR | 661 | 321 | NR | 849 | 415 | NR | 1264 | 640 | | |
| 30 | NR | NR | NR | NR | NR | NR | NR | 266 | 135 | NR | 398 | 195 | NR | 558 | 275 | NR | 739 | 377 | NR | 957 | 490 | NR | 1447 | 740 | | |
| 50 | NR | NR | NR | NR | NR | NR | NR | NR | NR | NR | NR | NR | NR | 612 | 325 | NR | 821 | 456 | NR | 1076 | 600 | NR | 1672 | 910 | | |

TABLE 9

**MASONRY CHIMNEY LINER DIMENSIONS
WITH CIRCULAR EQUIVALENTS**

| NOMINAL LINER SIZE INCHES | INSIDE DIMENSIONS IN LINER INCHES | INSIDE DIA. OR EQUIVALENT DIA. INCHES | EQUIVALENT AREA SQ. INCHES |
|---------------------------|-----------------------------------|---------------------------------------|----------------------------|
| 4 x 8 | 2 1/2 x 6 1/2 | 4 | 12.2 |
| | | 5 | 19.6 |
| | | 6 | 28.3 |
| | | 7 | 38.3 |
| 8 x 8 | 6 3/4 x 6 3/4 | 7.4 | 42.7 |
| | | 8 | 50.3 |
| 8 x 12 | 6 1/2 x 10 1/2 | 9 | 63.6 |
| | | 10 | 78.5 |
| 12 x 12 | 9 3/4 x 9 3/4 | 10.4 | 83.3 |
| | | 11 | 95 |
| 12 x 16 | 9 1/2 x 13 1/2 | 11.8 | 107.5 |
| | | 12 | 113 |
| | | 14 | 153.9 |
| 16 x 16 | 13 1/4 x 13 1/4 | 14.5 | 162.9 |
| | | 15 | 176.7 |
| 16 x 20 | 13 x 17 | 16.2 | 206.1 |
| | | 18 | 254.4 |
| 20 x 20 | 16 3/4 x 16 3/4 | 18.2 | 260.2 |
| | | 20 | 314.1 |
| 20 x 24 | 16 1/2 x 20 1/2 | 20.1 | 314.2 |
| | | 22 | 380.1 |
| 24 x 24 | 20 1/4 x 20 1/4 | 22.1 | 380.1 |
| | | 24 | 452.3 |
| 24 x 28 | 20 1/2 x 24 1/4 | 24.1 | 456.2 |
| 28 x 28 | 24 1/4 x 24 1/4 | 26.4 | 543.3 |
| | | 27 | 572.5 |
| 30 x 30 | 25 1/2 x 25 1/2 | 27.9 | 607 |
| | | 30 | 706.8 |
| 30 x 36 | 25 1/2 x 31 1/2 | 30.9 | 749.9 |
| | | 33 | 855.3 |
| 36 x 36 | 31 1/2 x 31 1/2 | 34.4 | 929.4 |
| | | 36 | 1017.9 |

When liner sizes differ dimensionally from those shown in Table 9 equivalent diameters may be determined from published tables for square and rectangular ducts of equivalent carrying capacity or by other engineering methods.

EXAMPLES USING SINGLE APPLIANCE VENTING TABLES

Example 1: Single Draft-Hood-Equipped Appliance

Suppose that an installer has a 120,000 Btu/hr input appliance with a 5 inch diameter draft hood outlet that needs to be vented into a 10 foot high Type B vent system. What size vent should be used assuming (a) a 5-Ft lateral single-wall metal vent connector is used with two 90° elbows, (b) a 5-Ft lateral single-wall metal vent connector is used with three 90° elbows in the vent system?

Solution

Table 2 should be used to solve this problem because single-wall metal vent connectors are being used with a Type B vent: Refer to Figure 4 of Typical Applications.

- a) Read down the first column in Table 2 until the row associated with a 10-Ft height and a 5-Ft lateral is found. Read across this row until a vent capacity greater than 120,000 Btu/hr is located in the shaded columns labeled "NAT Max" for draft-hood-equipped appliances. In this case, a 5 inch diameter vent has a capacity of 122,000 Btu/hr and may be used for this application.
- b) If three 90° elbows are used in the vent system, then the maximum vent capacity listed in the tables must be reduced by 10 percent (see Note 3). This implies that the 5 inch diameter vent has an adjusted capacity of only 110,000 Btu/hr. In this case, the vent system must be increased to 6 inches in diameter. See calculations below:

$$122,000 \times .90 = 110,000 \text{ for } 5'' \text{ Vent}$$

From Table 2—Select 6" Vent

$186,000 \times .90 = 167,000$; This is greater than the required 120,000, therefore use a 6" Vent and connector when three elbows are used.

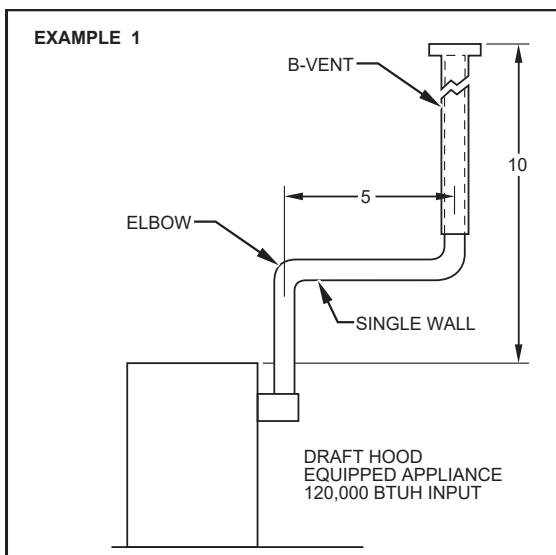

Example 2: Single Fan-Assisted Appliance

Suppose an installer has an 80,000 Btu/hr input fan-assisted appliance that must be installed using 10 feet of lateral connector attached to a 30-Ft high Type B vent. Two 90° elbows are needed for the installation. Can a single-wall metal vent connector be used for this application?

Solution

Table 2 refers to the use of single-wall metal vent connectors with Type B vent. In the first column find the row associated with a 30-Ft height and a 10-Ft lateral. Read across this row, looking at the "FAN Min" and "FAN Max" columns, to find that a 3 inch diameter single-wall metal connector vent is not recommended. Moving to the next larger size single wall connector (4") we find that a 4 inch diameter single-wall metal connector has a recommended minimum vent capacity of 91,000 Btu/hr and a recommended maximum vent capacity of 144,000 Btu/hr. The 80,000 Btu/hr fan-assisted appliance is outside this range, so we conclude that a single-wall metal vent connector cannot be used to vent this appliance using 10 feet of lateral for the connector.

However, we see that if the 80,000 Btu/hr input appliance could be moved to within 5 feet of the vertical vent, then a 4 inch single-wall metal connector could be used to vent the appliance. Table 2 shows the acceptable range of vent capacities for a 4 inch vent with 5 feet of lateral to be between 72,000 Btu/hr and 157,000 Btu/hr.

If the appliance cannot be moved closer to the vertical vent, then Type B vent could be used as the connector material. In this case, Table 1 shows that for a 30-Ft high vent with 10 feet of lateral, the acceptable range of vent capacities for a 4 inch diameter vent attached to a fan-assisted appliance are between 37,000 Btu/hr and 150,000 Btu/hr.

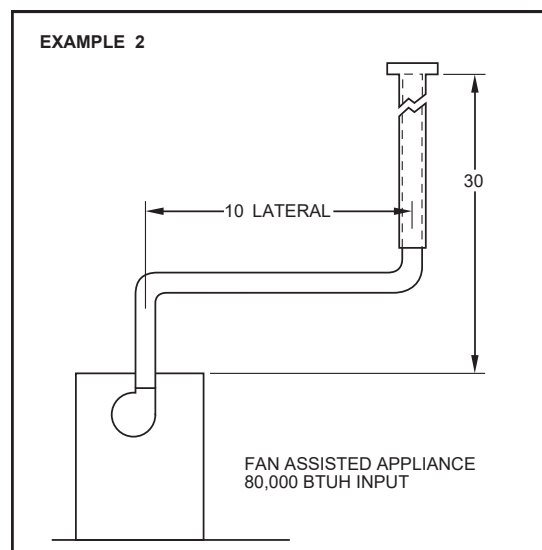

EXAMPLES USING COMMON VENTING TABLES

Example 3: Common Venting Two Draft-Hood Appliances

Suppose a 35,000 Btu/hr water heater is to be common vented with a 150,000 Btu/hr furnace using a common vent with a total height of 30 feet. The connector rise is 2 feet for the water heater and 3 feet for the furnace. Assume single-wall metal connectors will be used with Type B vent. What size connectors and combined vent should be used in this installation?

Solution—(Table 4 applies in this example)

Table 4 should be used to size single-wall metal vent connectors attached to Type B vertical vent. In the vent connector capacity Table 4, find the row associated with a 30-Ft vent height. For a 2-Ft rise on the vent connector for the water heater, read the shaded columns for draft-hood-equipped appliances to find that a 3 inch diameter vent connector has a capacity of 37,000 Btu/hr.

Therefore, a 3 inch single-wall metal vent connector may be used with the water heater. For a draft-hood-equipped furnace with a 3-Ft rise, read across the appropriate row to find that a 5 inch diameter vent connector has a maximum capacity of 120,000 Btu/hr (which is too small for the furnace) and a 6 inch diameter vent connector has a maximum vent capacity of 172,000 Btu/hr. Therefore, a 6 inch diameter vent connector should be used with the 150,000 Btu/hr furnace.

For the capacity of the combined vent, the lower portion of Table 4 should be used. The combined vent capacity required is 185,000 Btu/hr. Table 4 shows that the combined vent capacity of a 6 inch diameter vent with a 30-Ft vent height is 257,000 Btu/hr. This is more than adequate to handle the 35,000 Btu/hr input water heater and the 150,000 Btu/hr input furnace.

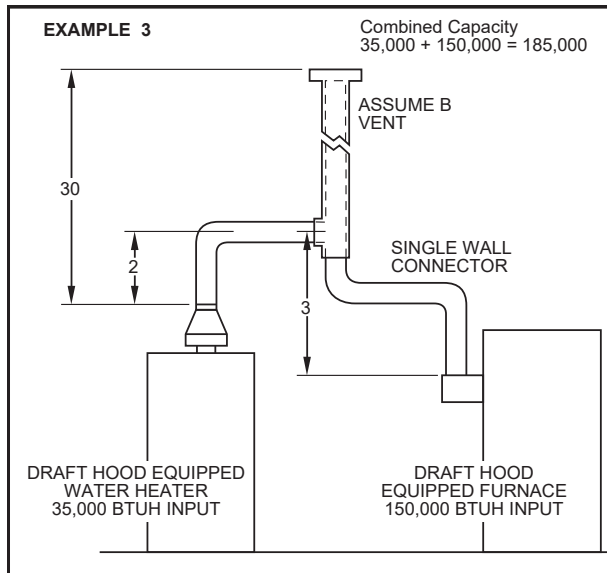

Example 4: Common Venting a Draft Hood Water Heater with a Fan-Assisted Furnace

In this case, a 35,000 Btu/hr input draft-hood-equipped water heater with a 2 foot connector rise is to be common vented with a 100,000 Btu/hr fan-assisted furnace with a 3-Ft connector rise. The common vent consists of a 30-Ft rise of Type B vent. What are the recommended vent diameters for each connector and the common vent?

Solution—(Table 4)

Water Heater Vent Connector Diameter. Let us assume the installer would like to use a single-wall metal vent connector. Using Table 4, Vent Connector Capacity, read down the Total Vent Height "H" column to 30 feet and read across the 2-Ft Connector Rise "R" row to the first Btu/hr rating in the "NAT Max" column that is equal to or greater than the water heater input rating. The table shows that a 3 inch vent connector has a maximum input rating of 37,000 Btu/hr. Since this is greater than the water heater input rating, a 3 inch vent connector is adequate. Furthermore, since the water heater is equipped with a draft hood, there are no minimum input rating restrictions.

Furnace Vent Connector Diameter. Again, let us assume the installer would like to use a single-wall metal vent connector. Using Table 4, Vent Connector Capacity, read down the Total Vent Height "H" column to 30 feet and across the 3-ft Connector Rise "R" row. Since the furnace has a fan-assisted combustion system, find the first "FAN Max" column with a Btu/hr rating greater than the furnace input rating. The 4 inch vent connector has a maximum input rating of 119,000 Btu/hr and a minimum input rating of 85,000 Btu/hr. The 100,000 Btu/hr furnace in this example falls within this range, so a 4 inch connector is adequate. If the furnace would have had an input rating of 80,000 Btu/hr, then a Type B vent connector (see Table 4) would have to be used in order to meet the minimum capacity limit.

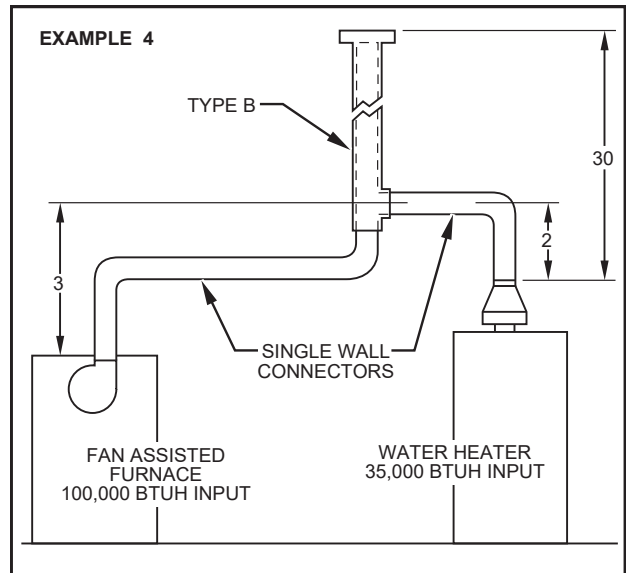

EXAMPLES USING COMMON VENTING TABLES

Example 4: (cont'd)

Common Vent Diameter. The total input to the common vent is 135,000 Btu/hr. Using Table 4, Common Vent Capacity, read down the Total Vent Height "H" column to 30 feet and across this row to find the smallest vent diameter in the "FAN+NAT" column that has a Btu/hr rating equal to or greater than 135,000 Btu/hr. The 4 inch common vent has a capacity of 132,000 Btu/hr and the 5 inch common vent has a capacity of 202,000 Btu/hr. Therefore, the 5 inch common vent should be used in this example.

Summary. In this example, the installer may use a 3 inch diameter, single-wall metal vent connector for the water heater and a 4 inch diameter, single-wall metal vent connector for the furnace. The common vent should be a 5 inch diameter Type B vent

Example 5: Single Draft Hood Equipped Furnace Vented into a Masonry Chimney

A 135,000 Btu/hr draft hood equipped furnace is to be vented into a 15' high tile lined masonry chimney. The chimney is not exposed to the outside except above the roof line. The furnace has a 6" diameter draft hood outlet and requires a 10' lateral vent connector with 3 elbows. The chimney is constructed using a 8" x 8" liner. What size single wall vent connector is required?

Solution:

Table 6 should be used. Refer to the figure for Example 5.

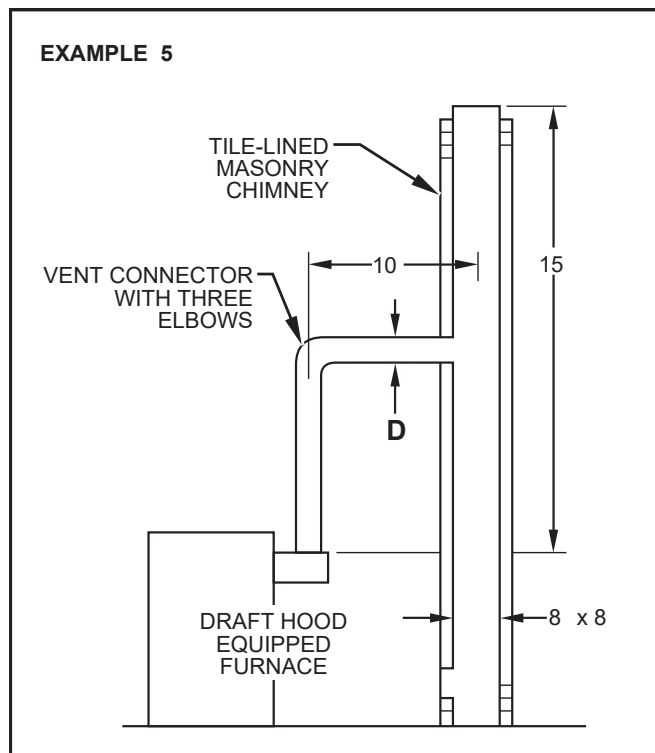

To determine the required vent connector diameter, read down the height column in Table 6 until 15' is found. Find the row for a 10' long lateral. The table shows that a 6" diameter connector will allow a maximum capacity of 151,000 Btu/hr for "Nat Max." (draft-hood equipped) furnace. Because 3 elbows are required, however, the maximum capacity must be reduced by 10% (See Note 3). Allowing for the additional elbow the corrected maximum capacity is 135,900 Btu/hr. A 6" diameter connector is large enough and should be used. The internal area of the chimney is 8" x 8" = 64 sq. in. and is within the acceptable range (38 sq. in. to 198 sq. in.) for a 6" vent connector as shown in Table 6.

Example 6: Common Venting into a Masonry Chimney
 In this case, a 35,000 Btu/hr input 4 inch diameter outlet draft hood-equipped water heater with 2 feet of connector rise and 4 feet of horizontal length is to be common vented with a 100,000 Btu/hr fan-assisted furnace with a 4 inch diameter flue collar, 3 feet of connector rise and 6 feet of horizontal length. The common vent is an 8 x 12 tile lined chimney that is 30 feet tall. What are the recommended vent diameters for each connector? Is this an acceptable installation?

Solution:

Table 8 is used to size common venting installations involving single wall connectors into masonry chimneys.

Water Heater Vent Connector Diameter. Using Table 8, Vent Connector Capacity, read down the Total Vent Height "H" column to 30 feet and read across the 2 ft Connector Rise "R" row to the first Btu/hr rating in the "NAT MAX" column that is equal to or greater than the water heater input rating. The Table shows that a 3 inch vent connector has a maximum input of only 31,000 Btu/hr while a 4 inch vent connector has a maximum input of 57,000 Btu/hr. A 4 inch vent connector must therefore be used.

Furnace Vent Connector Diameter. Using Table 8 Vent Connector Capacity, read down the Total Vent Height "H" column to 30 feet and across the 3 ft Connector Rise "R" row. Since the furnace has a fan-assisted combustion system, find the first "FAN MAX" column with a Btu/hr rating greater than the furnace input rating. The 4 inch vent connector has a maximum input rating of 127,000 Btu/hr and a minimum input rating of 95,000 Btu/hr. The 100,000 Btu/hr furnace in this example falls within this range, so a 4 inch connector is adequate.

EXAMPLE 6: (cont'd)

Masonry Chimney. From Table 9, the Equivalent Area for a Nominal Liner size of 8 inches x 12 inches is 63.6 square inches. Using Table 8, Common Vent Capacity, read down the "Fan + Nat" column under the Minimum Internal Area of Chimney value of 63 to the row for 30-ft height, to find a capacity value of 739,000 Btu/hr. The combined input rating of the furnace and water heater 135,000 Btu/hr, is less than the Table value, so this is an acceptable installation.

Note 19 requires the common vent area to be no greater than seven times the flow area of the smallest appliance outlet area. Both appliances in this installation use 4 inch diameter outlets. From Table 9, the Equivalent Area for an Inside Diameter of 4 inches is 12.2 square inches. Seven times 12.2 is 85.4, which is greater than 63.6, so this configuration is acceptable.

Note 1 specifies that the Table values are for vents or chimneys which are not exposed to the outdoors below the roofline. If the masonry chimney in this case were exposed below the roofline, then the appliance manufacturer, local gas utility, and/or authority having jurisdiction must be consulted.

EXAMPLE 7: Interpolating Between Table Values

An installer has an 80,000 Btu/hr input appliance with a 4 inch diameter draft hood outlet that needs to be vented into a 12-ft high Type B vent. The vent connector has a 5 ft lateral length and is also Type B. Can this appliance be vented using a 4 inch diameter vent?

Solution

Table 1 is used in the case of an all Type B vent system. However, since there is no entry in Table 1 for height of 12 feet, interpolation must be used. Read down the 4 inch diameter "NAT Max" column to the row associated with 10 ft. height and 5 ft. lateral to find the capacity value of 77,000 Btu/hr. Go down further to the 15 ft. height, 5 ft. lateral row to find the capacity value of 87,000 Btu/hr. The difference between the 15 ft. height capacity value and the 10 ft. height capacity value is 10,000 Btu/hr. The capacity for a vent system with a 12 ft. height is equal to the capacity for a 10 ft. height plus 2/5 of the difference between the 10 ft. and 15 ft. height values, or $77,000 + 2/5 \times 10,000 = 81,000$ Btu/hr. Therefore, a 4 inch diameter vent may be used in the installation.

Multi-story Gas Vent Design Procedure for Each Segment of System

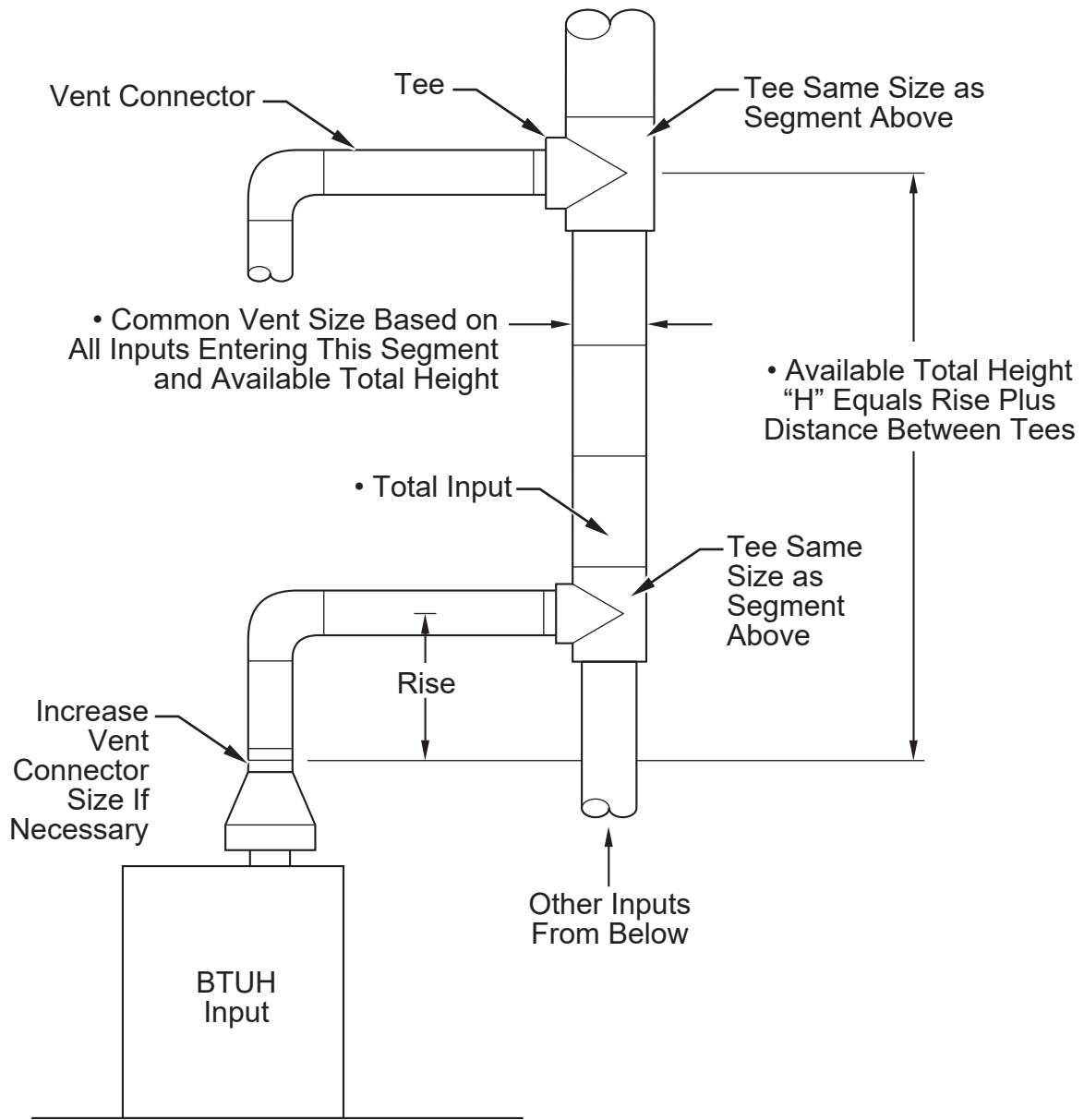

Vent Connector Size Depends On:

- Input
- Rise
- Available Total Height "H"
- Table 3 Connectors

Common Vent Size Depends On:

- Combined Inputs
- Available Total Height "H"
- Table 3 Common Vent
- Vertical Common Vent With No Offsets

Figure 13

Multi-story Vent System

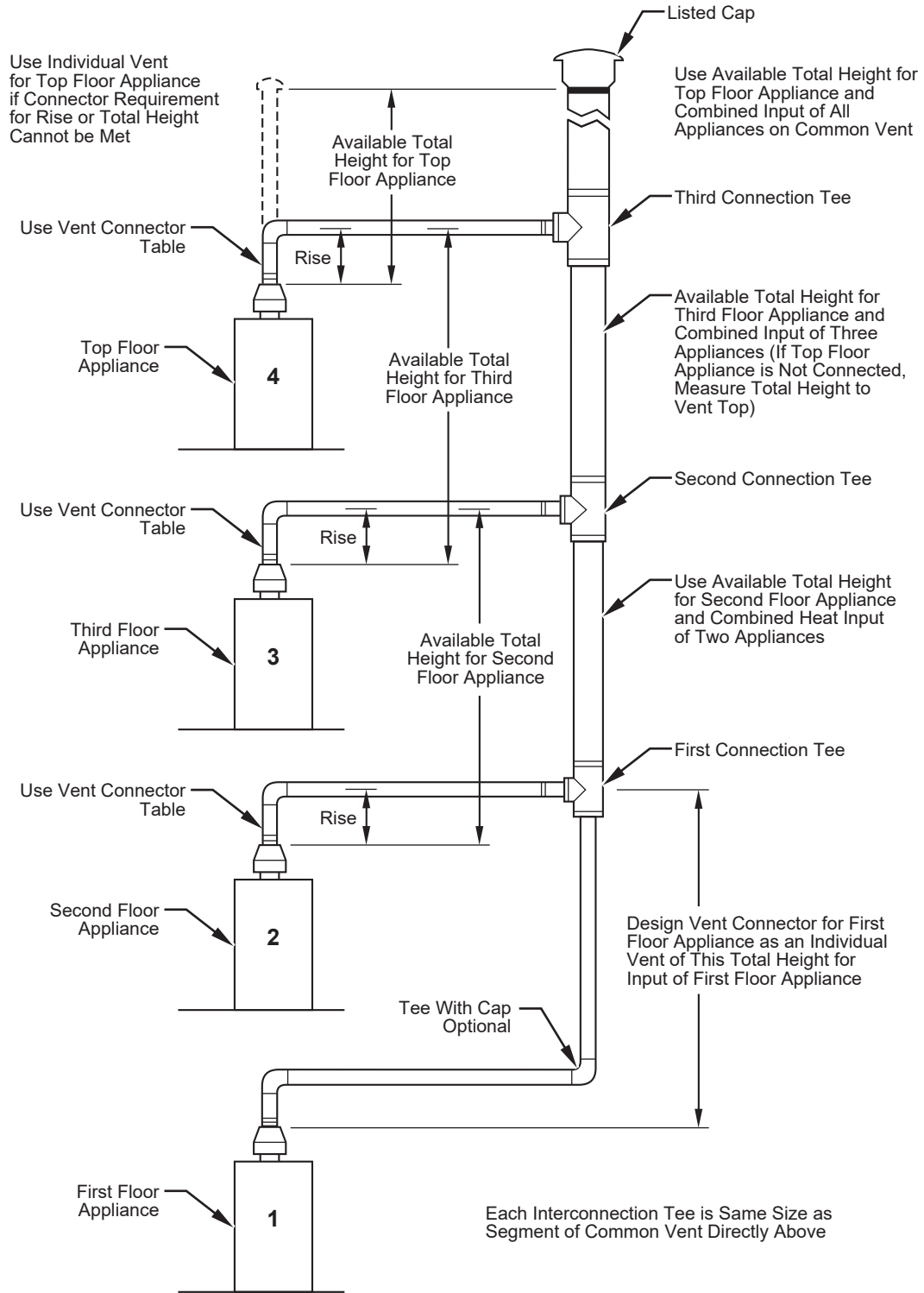

Principles of Design of Multi-story Vents Using Vent Connector and Common Vent Design Tables

Figure 14

