

N*VS BLOWER SECTIONS

GENERAL

This instruction covers the installation of the following variable speed blower sections.

- N1VSD10A06
- N1VSD14A06
- N2VSD20A06

The blower section is the basic component of an indoor modular system which may be combined with various accessories listed below to make an evaporator blower, evaporator blower with electric heat, heat pump blower, and heat pump blower with electric heat.

Because of the many ways this Air Handler may be applied and the large variety of available accessories, the indoor portion of the cooling or heat pump system comes to you in modules. These modules must be field assembled to meet the specific needs of the owner.

If this variable speed air handler is installed with a two stage (H*DS) outdoor condensing unit, a thermal expansion valve kit must be installed on the indoor side.

Check modules (accessories, etc.) received, against plans to be sure all required modules are available for assembly.

INSPECTION

As soon as a unit is received, it should be inspected for possible damage during transit. If damage is evident, the extent of the damage should be noted on the carrier's freight bill. A separate request for inspection by the carrier's agent should be made in writing. See Form 50.15-NM for more information.

REFERENCE

This instruction should be used in conjunction with installation instructions supplied with each accessory as well as the matching outdoor section.

Installer should pay particular attention to the words: NOTE, CAUTION and WARNING.

NOTES are intended to clarify or make the installation easier.

CAUTIONS are given to prevent equipment damage.

WARNINGS are given to alert the installer that personal injury and/or equipment damage may result if installation procedures are not handled properly.

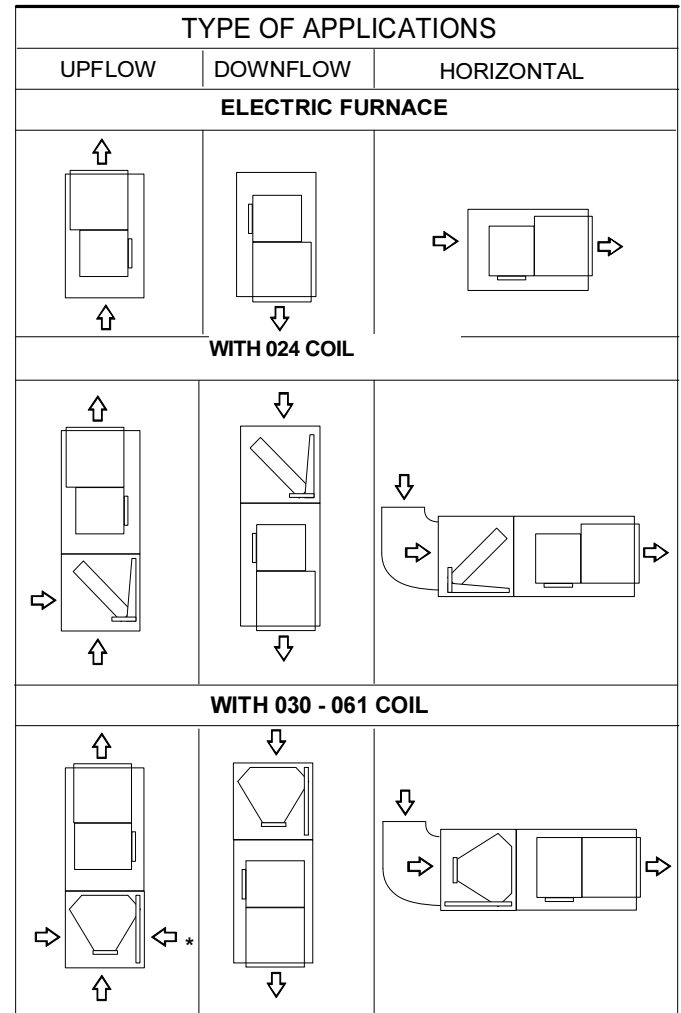

*Righthand return may be used by removing Horizontal Drain Pan
FIGURE 1 - Typical Component Application

CAUTION

THIS PRODUCT MUST BE INSTALLED IN STRICT COMPLIANCE WITH THE ENCLOSED INSTALLATION INSTRUCTIONS AND ANY APPLICABLE LOCAL, STATE, AND NATIONAL CODES INCLUDING, BUT NOT LIMITED TO, BUILDING, ELECTRICAL, AND MECHANICAL CODES.

WARNING

INCORRECT INSTALLATION MAY CREATE A CONDITION WHERE THE OPERATION OF THE PRODUCT COULD CAUSE PERSONAL INJURY OR PROPERTY DAMAGE.

CLICK ANYWHERE on THIS PAGE to RETURN to YORK HVAC AGE & MANUALS & ERROR CODES at InspectApedia.com

LIMITATIONS

These units must be wired and installed in accordance with all national and local safety codes.

Voltage limits are as follows:

Air Handler Voltage	*Normal Operating Voltage Range
208/230 (06)	187-253

*Utilization range "A" in accordance with ARI Std. 110.

Air flow must be within the minimum and maximum limits approved for electric heat, evaporator coils and outdoor units.

Entering Air Temperature Limits			
Wet Bulb Temp. °F		Dry Bulb Temp. °F	
MIN.	MAX.	MIN.	MAX.
57	72	65	95

CLEARANCE

Clearance must be provided for:

1. Refrigerant piping and connections - minimum 12" recommended.
2. Maintenance and servicing access - minimum 36" from front of unit recommended for blower motor / coil replacement.
3. Condensate drain line.
4. Filter removal - minimum 36" recommended.

LOCATION

Location is usually predetermined. Check with owner's or dealer's installation plans. If location has not been decided, consider the following in choosing a suitable location:

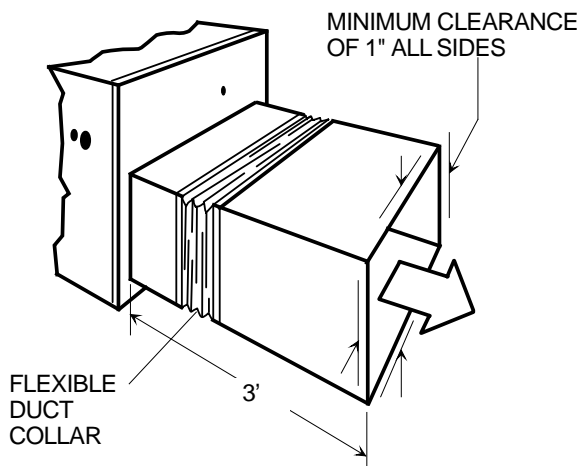

FIGURE 2 - Duct Clearance

1. Select a location with adequate structural support, space for service access, clearance for air return and supply duct connections.
2. Normal operating sound levels may be objectionable if the air handler is placed directly over some rooms such as bedrooms, study, etc. A flexible duct collar is recommended as shown in Figure 2 to minimize noise.

3. Precautions should be taken to locate the unit and ductwork so that supply air does not short circuit to the return air.
4. If evaporator coil is used, locate to permit installation of a trapped condensate line to an open drain.
5. When an evaporator coil is installed in an attic or above a finished ceiling, an auxiliary drain pan should be provided under the coil as is specified by most local building codes.

If the coil is provided with a secondary drain it should be trapped and piped to a location that will give the occupant a visual warning that the primary drain is clogged. If the secondary drain is not used it must be capped.

6. If unit is located in an area of high humidity, ie. an unconditioned garage or attic, nuisance sweating of casing may occur. On these installations a wrap of 2" fiberglass insulation with vinyl vapor barrier should be used.
7. Proper electrical supply must be available.
8. Clearances must also be taken into consideration, and provided for as follows:
 - a. Maintenance and servicing thru the front or access side of unit with both sides and rear of unit having zero inch clearance.
 - b. When no electric heat is used, the unit as well as all duct work and plenum are designed for zero clearance to combustible material.
 - c. If electric heat is used or anticipated, be sure a minimum clearance of one inch is allowed on all sides of the supply

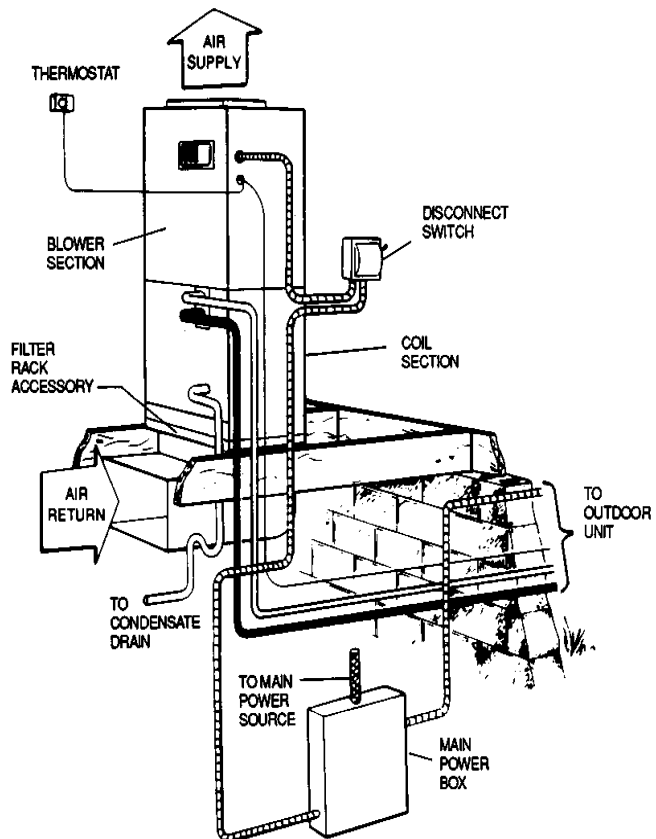

FIGURE 3 - Typical Wiring and Piping

air duct and plenum. This clearance must be maintained up to 3 feet a long the supply air duct. See Figure 2.

When a discharge plenum forms part of the duct work, it too must have one inch clearance on all sides.

DUCT CONNECTIONS

NOTE: The electric heat accessory should be installed before the supply air duct is attached to the supply air openings.

Air supply and return may be handled in one of several ways best suited to the installation. See Figure 4 for Air Handler inlet and outlet dimensions. Inlet dimensions of Air Handler are the same as coil casing outlet dimensions.

The vast majority of problems encountered with combination heating and cooling systems can be linked to improperly designed or installed duct systems. It is therefore highly important to the success of an installation that the duct system be properly designed and installed.

Use flexible duct collars to minimize the transmission of vibration/noise into the conditioned space. If electric heat is used non-flammable material must be used.

Where return air duct is short, or where sound is liable to be a problem, sound absorbing glass fiber should be used inside the duct. Insulation of duct work is a must where it runs through an unheated space during the heating season or through an un-cooled space during the cooling season. The use of a vapor barrier is recommended to prevent absorption of moisture from the surrounding air into the insulation.

The supply air opening on the fan unit should be enlarged to the proper duct size by use of a transition. All ducts should be suspended using flexible hangers and never fastened directly to the structure.

Duct work should be fabricated and installed in accordance with local and/or national codes. This includes the standards of the National Fire Protection Association for Installation of Air Conditioning and Ventilating Systems, NFPA No. 90A and Warm Air Heating and Air Conditioning Systems, NFPA No. 90B.

INDOOR UNIT PREPARATION

Prepare Air Handler for installation as follows:

Each accessory is provided with its own instruction.

1. Attach coil casing to blower section in a way appropriate to indoor unit application.

See Form 535.01-N5V for G*HC or G*FC Coils and Form 535.01-N6V for G*HT Coils

Confirm the orifice size before connecting line. The G*HC and G*FC coils will have an orifice installed in the fitting between the

liquid line connection and distributor. The orifice is identified on a label next to the liquid connection.

The orifice that is shipped with the coil is based on the "most sold" combination, but it may have to be changed, depending on the capacity and efficiency of the outdoor unit, elevation differences, and/or long total line lengths. See coil instruction and Application Data (Form 690.01-AD1V) for detailed piping guidelines.

If a thermal expansion valve kit is installed, the orifice must be removed.

The G*HT coils have a thermal expansion valve installed in the liquid line. An orifice is not included in this coil. Be sure the G*HT coil has been listed as a matched coil in the outdoor unit technical guide.

*NOTE: If a humidistat accessory is installed with the system, a thermal expansion valve kit or G*HT coil must be installed on the indoor side.*

If a two stage (H*DS) outdoor condensing unit is installed with this variable speed air handler a thermal expansion valve kit must be installed.

2. Install Combustible Floor Base accessory if applicable. The floor base is required on blower-heater combinations with greater than zero clearance in a downflow position on a combustible floor.

See Form 535.01- N1.5V

NOTE: Instructions for installing accessories are included with the accessories.

3. Attach Filter Rack Accessory if applicable. The filter rack is designed for use with G*HC, G*FC or G*HT coil or blower section.

See Form 535.01- N1.4V

CAUTION: Equipment should never be operated without filters.

4. Attach Suspension Kit if applicable. The suspension kit is designed to be used with all sizes of air handlers whenever the application requires horizontal or vertical suspension of the unit.

See Form 535.01 - N1.3V

5. Install Air Handler operating controls. A transformer accessory or an electric heater accessory must be supplied for the operation of the Air Handler.

See Form 535.03 - N1.1V
See Form 535.01 - N4.1V

NOTES: Power wiring may be brought into the unit through one of the knockouts in either the top or the right side panel. Multiple knockouts are provided to accommodate all of the electric heat and transformer accessories that are available. Use the knockouts that provide the best wire routing for the accessory being used.

All dimensions are in inches. They are subject to change without notice. Certified dimensions will be provided upon request.

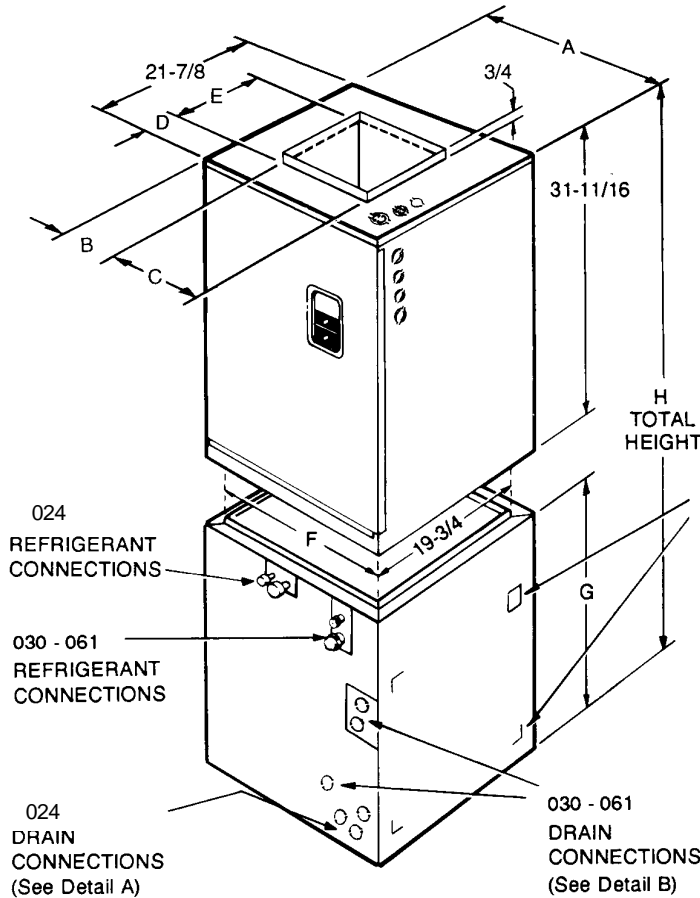

DETAIL "A"
024
DRAIN CONNECTIONS

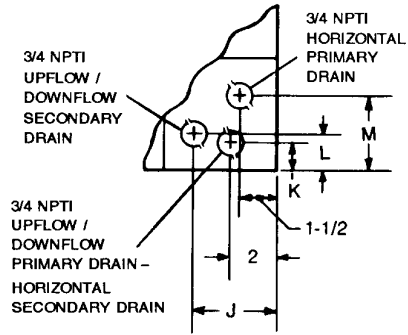

DETAIL "B"
030 - 061
DRAIN CONNECTIONS

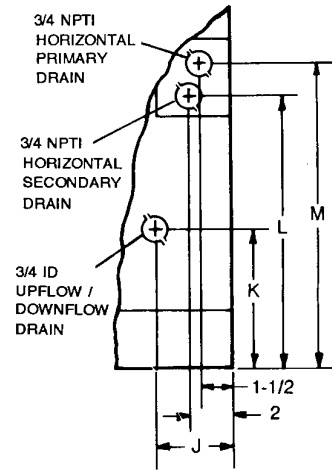

Blower Size	Coil Model GHC, GFC, GHT	Dimensions												Refrigerant* Connections					
		A	B	C	D	E	F	G	H	J	K	L	M	Quick Connect		Line Sizes			
														Liquid	Vapor	Liquid	Vapor		
D10	024	16-1/4	1	12-1/8	3-7/8	12-1/8	14-1/4	22-3/4	54-1/2	3-1/2	1-1/2	1-3/4	3-1/2	F-6	F-11	5/16	5/8		
	030						14-1/4	22-3/4	54-1/2	3-1/4	6-3/8	14-7/8	16-7/8					5/16	3/4
D14	036	22-1/4	3-5/8	14-7/8	3-7/8	12-1/8	20-1/4	22-3/4	54-1/2	6	7-3/8	14-7/8	16-7/8			F-6	F-11	3/8	7/8
	042						20-1/4	27-7/8	59-5/8	6	8-1/8	20	22						
D20	048	26-1/4	5-5/8	14-7/8	3-7/8	12-1/8	24-1/4	27-7/8	59-5/8	8	6-3/4	20	22	F-6	F-11			3/8	7/8
	060							31-3/8	63-1/8	7-1/4	7-5/8	23-1/2	25-1/2						
	60D** 061**																		

*G*HT coils are available as sweat connect only.

**G*HT coil models only.

FIGURE 4 - DIMENSIONS

ELECTRICAL CONNECTIONS

Wire Transformer Kit or Electric Heater per wiring diagram on the accessory. Typical field wiring is shown in Figures 9, 10 and 11.

CAUTION: Break off tab must be removed from 2HW electric heat control boards for variable speed operation. See Figure 6.

NOTE: All wiring must comply with local and national electrical code requirements. Read and heed all unit caution labels.

LINE POWER CONNECTIONS

Power may be brought into the unit through the supply air end of the unit (top when unit is vertical) or the right side panel. Use the hole appropriate to the unit's orientation in each installation to bring conduit from the disconnect. The power lead conduit should

be terminated at the transformer or electric heater box. Refer to Tables 2 and 5 for single source wire sizes. Also see Figure 5.

ALTERNATE LINE POWER CONNECTIONS

When desired or required by local conditions the units equipped with circuit breakers may be field converted to use multiple power sources, this will permit the use of smaller size power wire but will require a greater number of wires. To accomplish this field conversion refer to Figure 5 - (Dual Supply) as an example and proceed as follows.

1. Remove the jumper bar assembly and cover at the line side connection to the circuit breakers.
2. Select the proper wire size from Table 3.
3. Connect the multiple power sources direct to the circuit breakers.

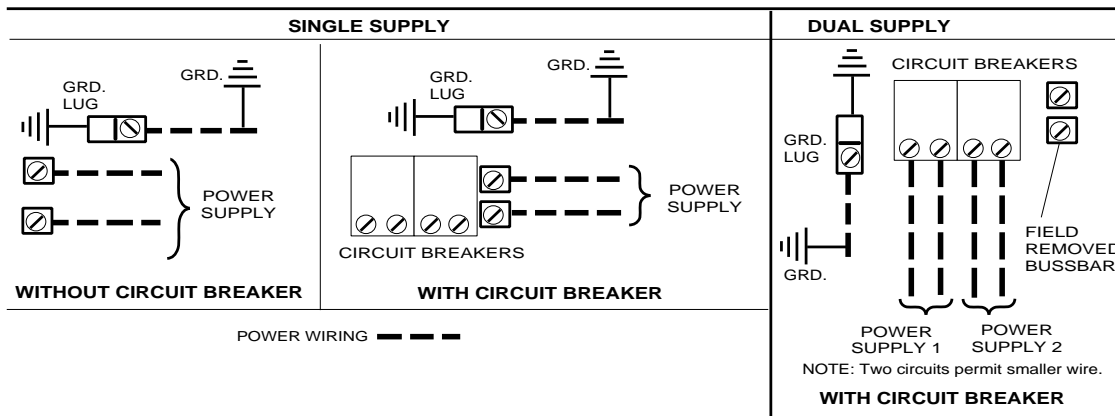
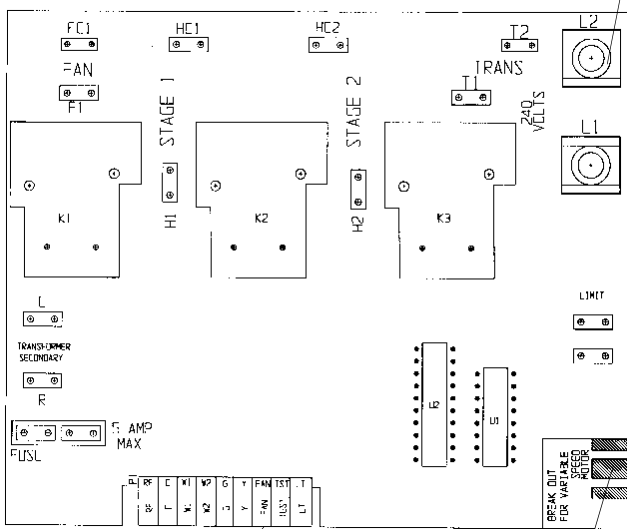

FIGURE 5 - Line Power Connections

5, 7.5 & 10 KW CONTROL BOARDS

NOTE: LINE VOLTAGE POWER CONNECTS DIRECTLY TO 10 KW BOARDS



EDGE CONNECTOR
(For Wiring Harness that attaches to Connection Board)

BREAK OFF TABS
(For Variable Speed Air Handler ONLY - must be removed)

12.5, 15 & 20 KW CONTROL BOARDS

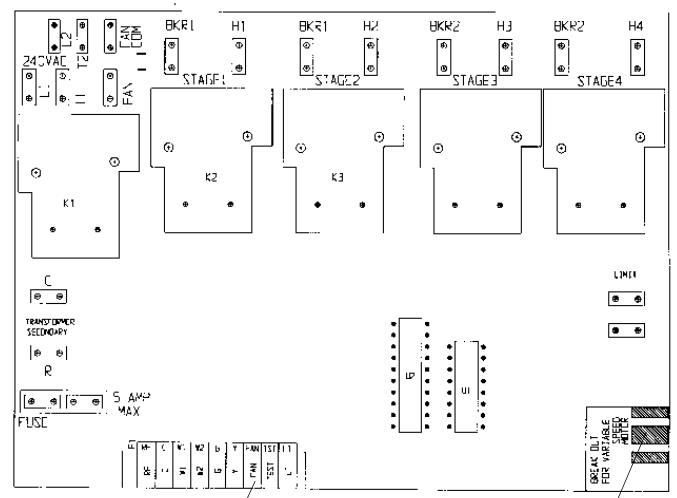

EDGE CONNECTOR
(For Wiring Harness that attaches to Connection Board)

BREAK OFF TABS
(For Variable Speed Air Handler ONLY - must be removed)

FIGURE 6 - Typical Electric Heat Control Boards- (5-20KW Single Phase)

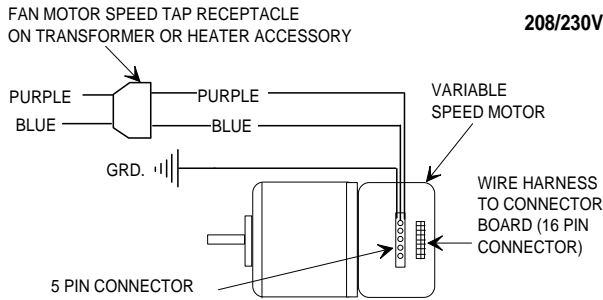

FIGURE 7 - Blower Connections

LOW VOLTAGE CONTROL CONNECTIONS

Use 7/8 inch knockout on the left hand side panel to bring low voltage wiring into air handler.

CAUTION: Use 7/8 inch plastic bushing provided to prevent chafing wires.

All field control wiring to be connected at screw terminals of connector board. See Figure 8.

Remove control wiring harness supplied with 2HW electric heat accessory and discard. Every connector board is supplied with a complete electric heat wiring harness connected to the lower right hand corner of connector board (See Figure 8). Plug in free end of wiring harness to electric heat control board. If the transformer kit is installed, discard electric heat wiring harness attached to connector board. Install wiring harness provided with transformer accessory at the connection in lower right hand corner of connector board.

Field supplied low voltage wiring must be kept as short as possible and away from the blower motor wires. Refer to Table 2, 3 or 5 for minimum wire size.

The 24 volt power supply is provided by an internally wired low voltage transformer. However, if the unit is connected to a 208 volt power supply the low voltage transformer must be rewired to the 208 volt tap. See the unit wiring label.

See Figure 9, 10 and 11 for low voltage terminal connections.

If thermostat used has an adjustable heat anticipator, see Table below for proper setting.

HEAT ANTICIPATOR SETTING

Electric Heater with Cooling or Electric Heater Only	KW	Adjustable Heat Anticipator
2HW	5 - 20	0.1 Amps

BLOWER SPEED SELECTION

All variable speed air handlers (N*VS) are designed to deliver constant CFM regardless of the external static pressure (ESP) in the ductwork. Therefore, if too many supply registers are closed, a filter becomes clogged, or there is a restriction in the ductwork, the motor will automatically operate at a higher speed to compensate for the higher ESP. This may result in a higher operating sound level.

To Set Cooling CFM:

Refer to the outdoor unit technical guide for the recommended airflow with the matching evaporator coil. Refer to the label on the blower housing or Table 1 for the possible HI speed cooling and/or

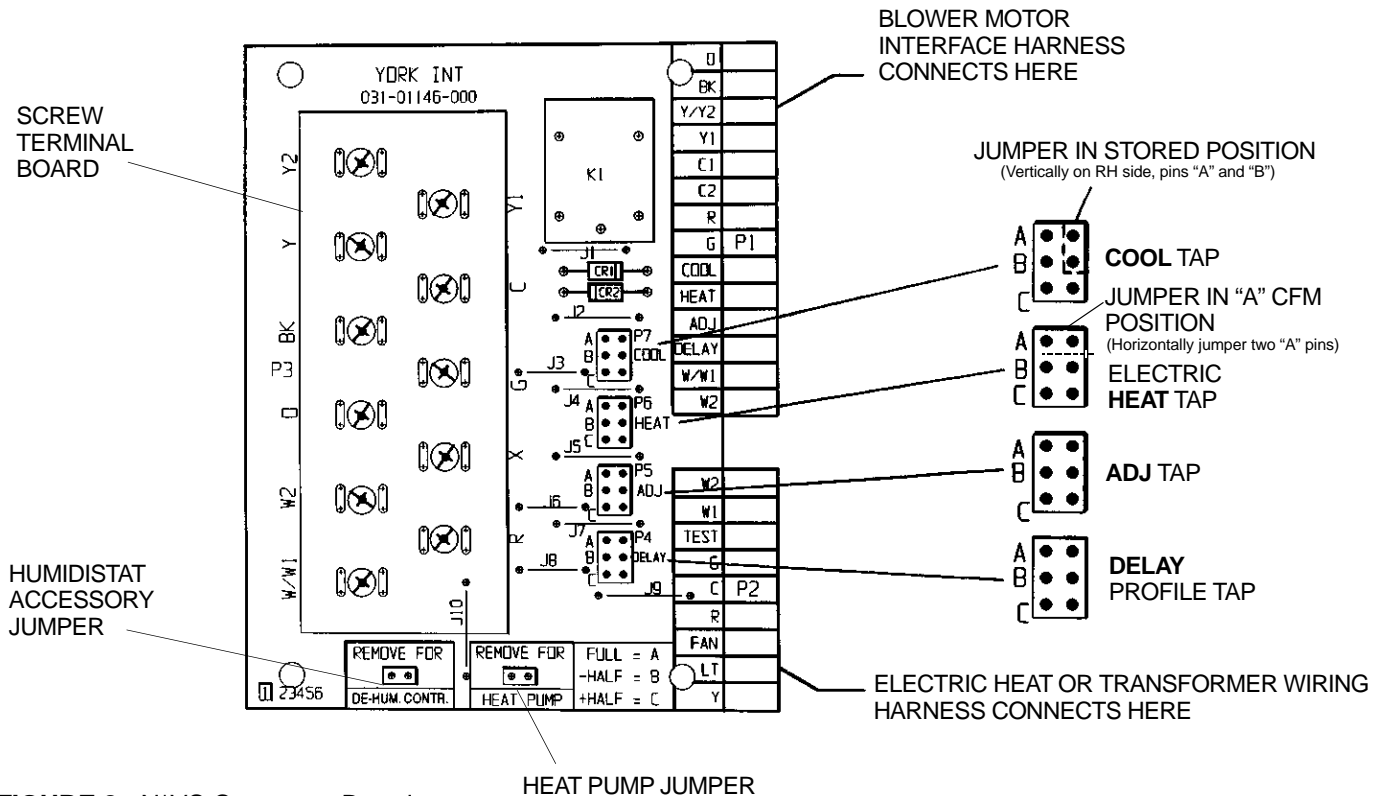

FIGURE 8 - N*VS Connector Board

heat pump CFM selections. Find the recommended system airflow in the table for the installed Air Handler model.

Moving up the table, identify the "COOL" tap jumper position ("A", "B", "C" or No Jumper). Go to the connector board and set the jumper horizontally for the "COOL" tap position. See Figure 8 for the layout of the connector board.

NOTE: No jumper indicates the jumper should be removed or placed in the "store" position (see Figure 8).

Return to Table 1 and move to the right to identify the "ADJ" tap jumper position. Go to the connector board and set the jumper horizontally for the "ADJ" tap position (refer to Figure 8). Again, "No jumper" indicates the jumper should be removed or placed in the "store" position.

To Set Heat Pump CFM:

The heat pump CFM setting is the same as the cooling CFM. No additional CFM setting is required, however, you must remove the jumper at the bottom of the connector board labeled "Remove for Heat Pump" for heat pump operation. (See Figure 8.)

To Set Electric Heat CFM:

The blower speed required for the Electric Heat is different than cooling. Refer to the label on the blower housing or Table 1 for the possible CFM selections. Refer to Table 4 for the minimum required CFM for the electric heater installed. Find the desired airflow in Table 1. Moving up the table, identify the "HEAT" tap jumper position. Go to the connector board and set the jumper horizontally for the "HEAT" tap position.

CAUTION: DO NOT change the "ADJ" tap position on the connector board as this will change your cooling CFM previously selected.

To Set Delay Profile:

Every variable speed air handler has multiple "blower off delay" profiles to optimize system performance and efficiency.

Refer to Table below for the type of system installed. set the "DELAY" jumper tap position horizontally on the connector board for the appropriate setting.

Delay Profile	
"DELAY" Tap	Unit Type
Jumper at "A"	System wo/TXV or wo/ S.V.
Jumper at "B"	System w/TXV or w/ S.V.
Jumper at "C"	Two Stage Condensor
No Jumper	Test Mode

*TXV= Thermal Expansion Valve
SV= Solenoid Valve*

To Install Humidistat Accessory:

If the system is used with a humidistat accessory, connect the field wires to screw terminals "R" and "BK" on the connector board. See Figures 10 or 11.

IMPORTANT: Remove the jumper at the bottom of the connector board marked "Remove for Humidistat" for humidistat operation.

MAINTENANCE

One permanent high velocity washable filter is provided with each filter rack. This filter may be cleaned with a vacuum cleaner or washed with warm water using a mild detergent. Do not use a high velocity water stream. No coating is required. Install filter with cloth mesh towards blower. Never turn a dirty filter to allow air flow in the opposite direction.

Filters must be cleaned when they become dirty. Inspect at least once per month. The frequency of cleaning depends upon the hours of operation and the local atmospheric conditions. Clean filters keep unit efficiency high.

COIL CLEANING

If the coil needs to be cleaned, it should be washed with Calgon Coilclean (mix one part Coilclean to seven parts water). Allow solution to remain on coil for 30 minutes before rinsing with clean water. Solution should not be permitted to come in contact with painted surfaces.

TABLE 4 - ELECTRICAL DATA / HEATER ACCESSORY

Blower Size	Heater Accessory Model No.	Min. CFM Cooling or Heat Pump	Total Heat ¹		KW Staging	
			KW	MBH	1st	2nd
			208/240	208/240	208/240	208/240
208/230-1-60 HEATERS						
N1VSD10	2HW06500506	900	3.8/5.0	13.0/17.1	3.8/5.0	-
	2HW06500806	950	5.0/7.5	19.1/25.6	3.8/5.0	1.8/2.5
	2HW06501006	1000	7.5/10.0	25.6/34.2	3.8/5.0	3.8/5.0
	2HW26501006	1000	7.5/10.0	25.6/34.2	3.8/5.0	3.8/5.0
	2HW06501306	1050	9.4/12.5	32.1/42.7	3.8/5.0	5.6/7.5
	2HW06501506	1100	11.3/15.0	38.6/51.2	3.8/5.0	7.5/10.0
N1VSD14	2HW06502006	1100	15.0/20.0	51.2/68.3	3.8/5.0	11.3/15.0
	2HW06500506	1100	3.8/5.0	13.0/17.1	3.8/5.0	-
	2HW06500806	1100	5.0/7.5	19.1/25.6	3.8/5.0	1.8/2.5
	2HW06501006	1200	7.5/10.0	25.6/34.2	3.8/5.0	3.8/5.0
	2HW26501006	1200	7.5/10.0	25.6/34.2	3.8/5.0	3.8/5.0
	2HW06501306	1300	9.4/12.5	32.1/42.7	3.8/5.0	5.6/7.5
N2VSD20	2HW06501506	1300	11.3/15.0	38.6/51.2	3.8/5.0	7.5/10.0
	2HW06502006	1400	15.0/20.0	51.2/68.3	3.8/5.0	11.3/15.0
	2HW06500506	1200	3.8/5.0	13.0/17.1	3.8/5.0	-
	2HW06500806	1200	5.0/7.5	19.1/25.6	3.8/5.0	1.8/2.5
	2HW06501006	1300	7.5/10.0	25.6/34.2	3.8/5.0	3.8/5.0
	2HW26501006	1300	7.5/10.0	25.6/34.2	3.8/5.0	3.8/5.0
N2VSD20	2HW06501306	1450	9.4/12.5	32.1/42.7	3.8/5.0	5.6/7.5
	2HW06501506	1450	11.3/15.0	38.6/51.2	3.8/5.0	7.5/10.0
	2HW06502006	1600	15.0/20.0	51.2/68.3	3.8/5.0	11.3/15.0

TABLE 5 - ELECTRICAL DATA / HEATER ACCESSORY

Blower Size	Heater Accessory Model No.	Field Wiring - 208/240			Factory-Installed Over-Current Protection
		Min. Ckt. Ampacity	Max. Overcurrent Prot. Amps/Type	Wire Size, AWG* 75°C Copper	
208/230-1-60 HEATERS					
N1VSD10	2HW06500506	26/30	30/35	10/8	NONE
	2HW06500806	37/43	40/45	8/8	NONE
	2HW06501006	48/56	50/60	8/6	NONE
	2HW26501006	48/56	50/60	8/6	BREAKER
	2HW06501306	60/68	60/70	6/4	BREAKER
	2HW06501506	71/82	80/90	4/4	BREAKER
N1VSD14	2HW06502006	94/108	100/125	3/2	BREAKER
	2HW06500506	28/31	30/35	10/8	NONE
	2HW06500806	39/44	40/45	8/8	NONE
	2HW06501006	51/58	60/60	6/6	NONE
	2HW26501006	51/58	60/60	6/6	BREAKER
	2HW06501306	62/71	70/80	6/4	BREAKER
N2VSD20	2HW06501506	73/83	80/90	4/4	BREAKER
	2HW06502006	96/110	100/110	3/2	BREAKER
	2HW06500506	31/35	35/35	8/8	NONE
	2HW06500806	43/48	45/50	8/8	NONE
	2HW06501006	54/61	60/60	6/6	NONE
	2HW26501006	54/61	60/60	6/6	BREAKER
N2VSD20	2HW06501306	65/74	70/80	6/4	BREAKER
	2HW06501506	76/87	80/90	4/4	BREAKER
	2HW06502006	99/113	100/125	3/2	BREAKER

NOTE: Air handler and heater accessory may be combined without a coil for electric furnace applications. Model Number suffix indicates voltage. 06=208/230-1-60.

* NOTE: 60°C and 90°C wire may be used. Reference the latest edition of National Electrical Code for proper wire size.

¹KW & MBH CONVERSIONS:

FOR	208-VOLT	OPERATION, MULTIPLY	240-VOLT	TABULATED KW & MBH BY	.751
	230-VOLT		240-VOLT		.918

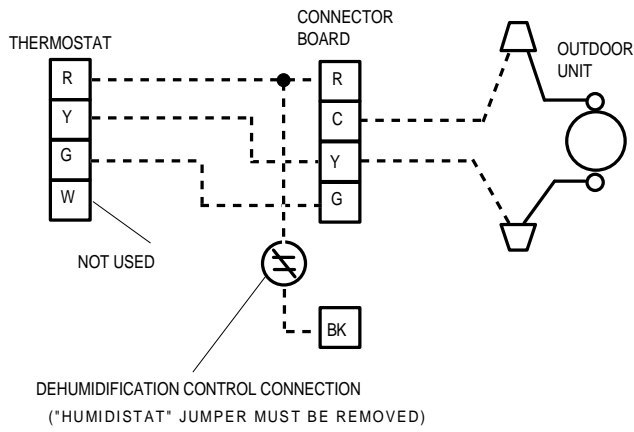

**COOLING UNITS 208/230 VOLT
MODELS H*DA and H*DH**

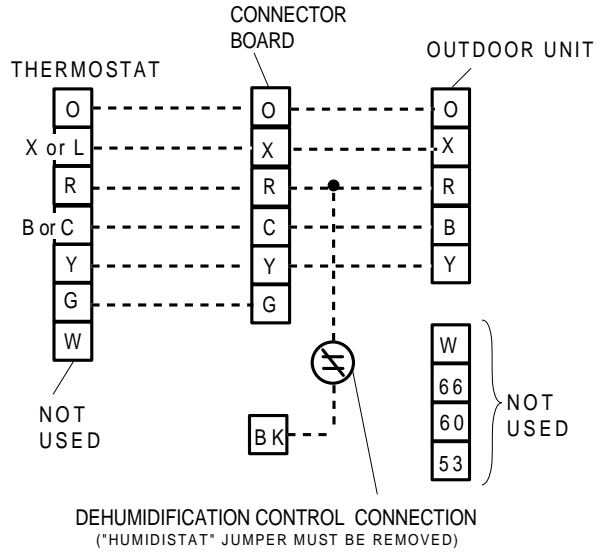

**HEAT PUMPS 208/230 VOLT
MODELS E*FB and E*FH**

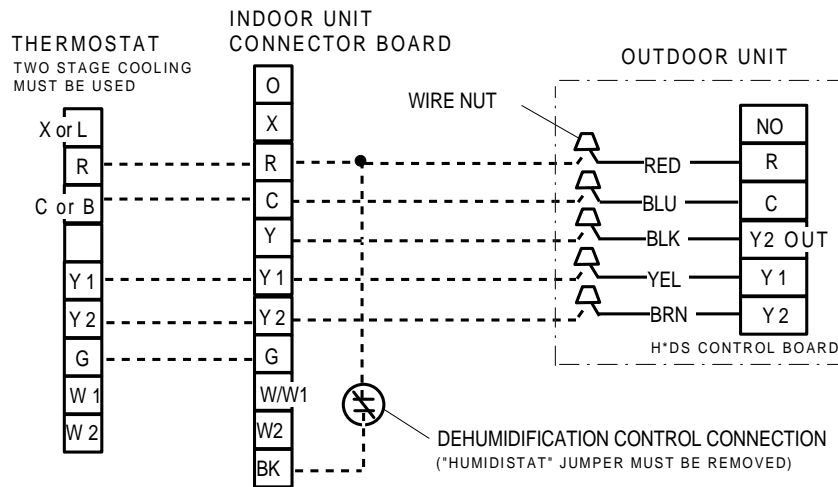

COOLING UNIT 208/230 MODELS H*DS

FIGURE 9 - Control Wiring / Transformer Accessory

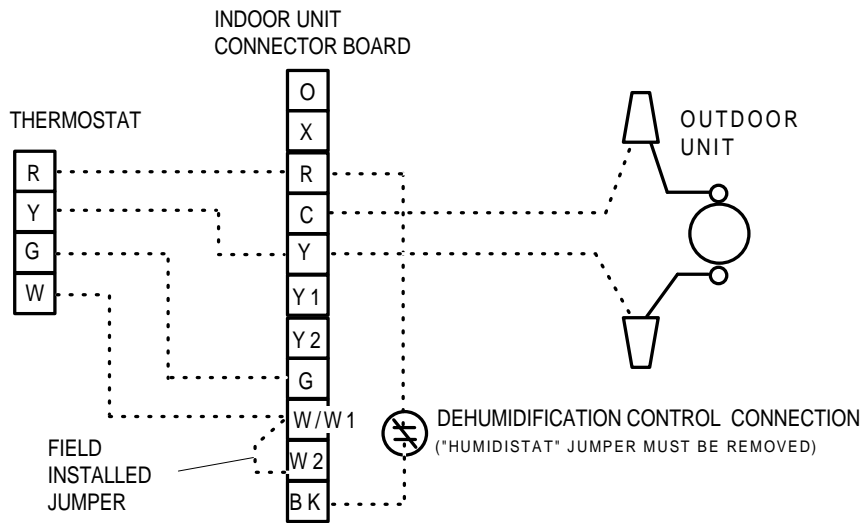

COOLING WITH ELECTRIC HEAT MODELS H*DA and H*DH

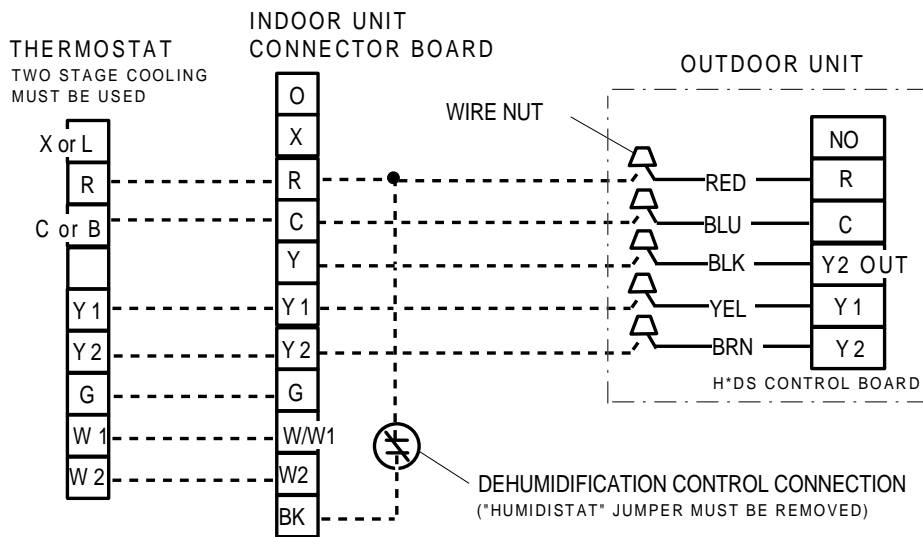

COOLING WITH ELECTRIC HEAT MODEL H*DS

FIGURE 10 - Control Wiring / Electric Heat - COOLING

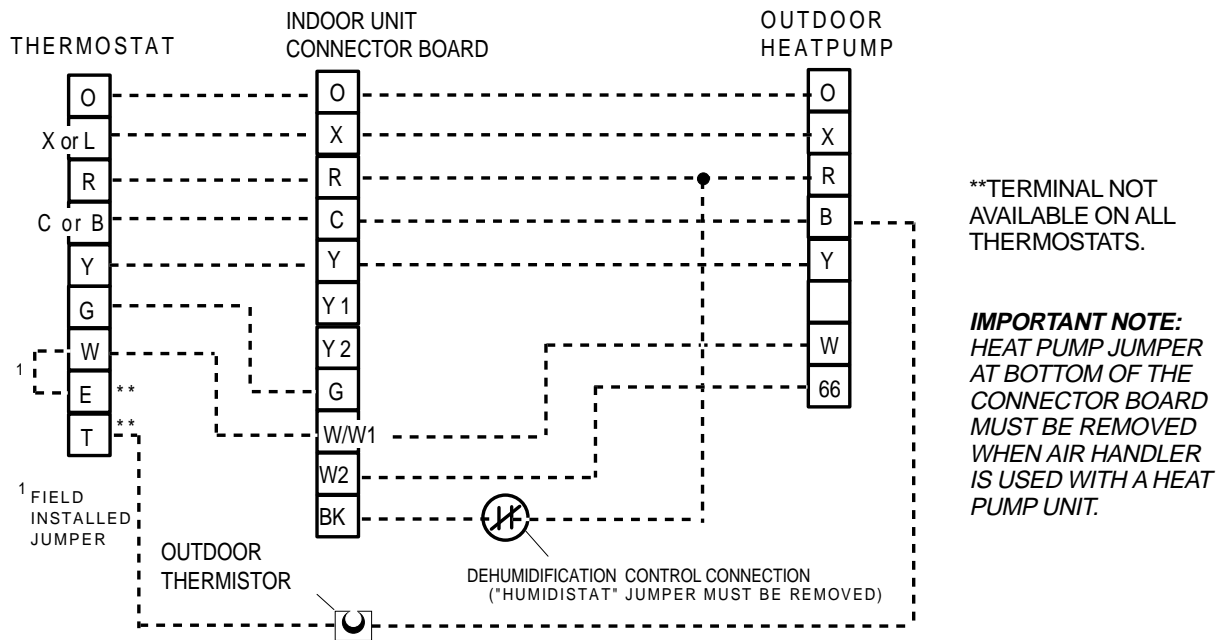

**HEAT PUMP (1 Phase)
MODELS E*FB**

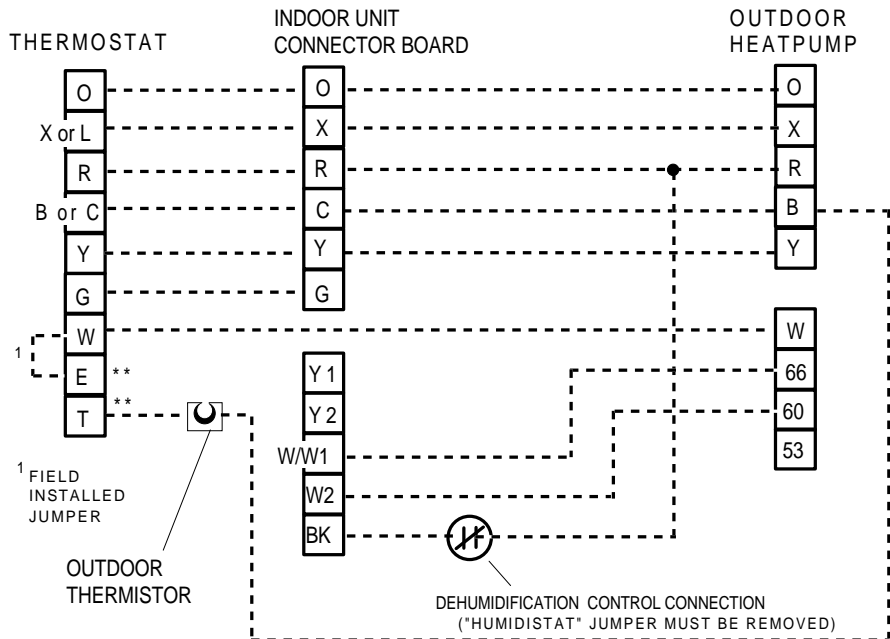

HEAT PUMP MODELS E*FH

FIGURE 11 - Control Wiring with Electric Heat - HEAT PUMP

