



stratus[®]

thermal management

TA10 Series User Manual





Stratus TA10 Series User Manual

Please include the Manual Number and the Manual Issue, both shown below, when communicating with Technical Support regarding this publication.

Manual Number: STRATUS_TA10_UM_WMO_2ed_RevD
 Issue: 2nd Edition Rev. D
 Issue Date: 08/10

Publication History		
Issue	Date	Description of Changes
First Edition	08/02/2010	Original
Second Edition	06/05/2014	
Rev. A	12/12/2016	Unit Specifications Amps and Refrigerant Updated, pgs 8-9 Frame Size 2 Dimensions Drawing Updated, pg 19 Frame Size 3 Dimensions Drawing Updated, pg 21 480V Schematic, Note Added pg 25 Manual renamed Stratus TA10 User Manual Logo changed from Trademark to Registered Trademark
Rev B	07/2/2018	Unit Specifications Amps Updated, pgs 8-9.
Rev C	05/23/2019	Unit Specifications Updated pg. 8.
Rev D	10/15/2021	Unit Specifications for 2,000 BTU units Ambient Temperature, Running Amps, Refrigerant Type and Amount, pgs 8-9 Replacement filter image pg 15 Power Terminal and Alarm Contact Wiring Diagrams pgs 17 and 19 Schematics pgs 23-25

TABLE OF CONTENTS

Overview	5
Unpacking STRATUS Air Conditioning Equipment	6
What's in the Box	6
Nameplate Information	6
Inspecting the Equipment	6
Basic Operation	7
Features	8
Unit Specifications	8
Preliminary Testing	10
Mounting the Air Conditioner	10
System Operation	11
System Faults	11
Alarm Conditions	11
Digital Temperature Controller	12
Functions and Parameters	13
Preventative Maintenance	15
Troubleshooting Guide	16
Dimensions	17
Schematics	23
Notes and Model Information	26

~ WARNING ~

Thank you for purchasing automation equipment from Automationdirect.com™, doing business as AutomationDirect. We want your new automation equipment to operate safely. Anyone who installs or uses this equipment should read this publication (and any other relevant publications) before installing or operating the equipment.

To minimize the risk of potential safety problems, you should follow all applicable local and national codes that regulate the installation and operation of your equipment. These codes vary from area to area and usually change with time. It is your responsibility to determine which codes should be followed, and to verify that the equipment, installation, and operation are in compliance with the latest revision of these codes.

At a minimum, you should follow all applicable sections of the National Fire Code, National Electrical Code, and the codes of the National Electrical Manufacturer's Association (NEMA). There may be local regulatory or government offices that can also help determine which codes and standards are necessary for safe installation and operation.

Equipment damage or serious injury to personnel can result from the failure to follow all applicable codes and standards. We do not guarantee the products described in this publication are suitable for your particular application, nor do we assume any responsibility for your product design, installation, or operation.

Our products are not fault-tolerant and are not designed, manufactured or intended for use or resale as on-line control equipment in hazardous environments requiring fail-safe performance, such as in the operation of nuclear facilities, aircraft navigation or communication systems, air traffic control, direct life support machines, or weapons systems, in which the failure of the product could lead directly to death, personal injury, or severe physical or environmental damage ("High Risk Activities"). AutomationDirect specifically disclaims any expressed or implied warranty of fitness for High Risk Activities.

For additional warranty and safety information, see the Terms and Conditions section of our catalog. If you have any questions concerning the installation or operation of this equipment, or if you need additional information, please call us at 770-844-4200.

This publication is based on information that was available at the time it was printed. At AutomationDirect we constantly strive to improve our products and services, so we reserve the right to make changes to the products and/or publications at any time without notice and without any obligation. This publication may also discuss features that may not be available in certain revisions of the product.

Trademarks

This publication may contain references to products produced and/or offered by other companies. The product and company names may be trademarked and are the sole property of their respective owners. AutomationDirect disclaims any proprietary interest in the marks and names of others.

**Copyright 2009-2010, 2016, 2018, Automationdirect.com™ Incorporated
All Rights Reserved**

No part of this manual shall be copied, reproduced, or transmitted in any way without the prior, written consent of Automationdirect.com™ Incorporated. AutomationDirect retains the exclusive rights to all information included in this document.

~ AVERTISSEMENT ~

Nous vous remercions d'avoir acheté l'équipement d'automatisation de Automationdirect.com™, en faisant des affaires comme AutomationDirect. Nous tenons à ce que votre nouvel équipement d'automatisation fonctionne en toute sécurité. Toute personne qui installe ou utilise cet équipement doit lire la présente publication (et toutes les autres publications pertinentes) avant de l'installer ou de l'utiliser.

Afin de réduire au minimum le risque d'éventuels problèmes de sécurité, vous devez respecter tous les codes locaux et nationaux applicables régissant l'installation et le fonctionnement de votre équipement. Ces codes diffèrent d'une région à l'autre et, habituellement, évoluent au fil du temps. Il vous incombe de déterminer les codes à respecter et de vous assurer que l'équipement, l'installation et le fonctionnement sont conformes aux exigences de la version la plus récente de ces codes.

Vous devez, à tout le moins, respecter toutes les sections applicables du Code national de prévention des incendies, du Code national de l'électricité et des codes de la National Electrical Manufacturer's Association (NEMA). Des organismes de réglementation ou des services gouvernementaux locaux peuvent également vous aider à déterminer les codes ainsi que les normes à respecter pour assurer une installation et un fonctionnement sûrs.

L'omission de respecter la totalité des codes et des normes applicables peut entraîner des dommages à l'équipement ou causer de graves blessures au personnel. Nous ne garantissons pas que les produits décrits dans cette publication conviennent à votre application particulière et nous n'assumons aucune responsabilité à l'égard de la conception, de l'installation ou du fonctionnement de votre produit.

Nos produits ne sont pas insensibles aux défaillances et ne sont ni conçus ni fabriqués pour l'utilisation ou la revente en tant qu'équipement de commande en ligne dans des environnements dangereux nécessitant une sécurité absolue, par exemple, l'exploitation d'installations nucléaires, les systèmes de navigation aérienne ou de communication, le contrôle de la circulation aérienne, les équipements de survie ou les systèmes d'armes, pour lesquels la défaillance du produit peut provoquer la mort, des blessures corporelles ou de graves dommages matériels ou environnementaux («activités à risque élevé»). La société AutomationDirect nie toute garantie expresse ou implicite d'aptitude à l'emploi en ce qui a trait aux activités à risque élevé.

Pour des renseignements additionnels touchant la garantie et la sécurité, veuillez consulter la section Modalités et conditions de notre documentation. Si vous avez des questions au sujet de l'installation ou du fonctionnement de cet équipement, ou encore si vous avez besoin de renseignements supplémentaires, n'hésitez pas à nous téléphoner au 770-844-4200.

Cette publication s'appuie sur l'information qui était disponible au moment de l'impression. À la société AutomationDirect, nous nous efforçons constamment d'améliorer nos produits et services. C'est pourquoi nous nous réservons le droit d'apporter des modifications aux produits ou aux publications en tout temps, sans préavis ni quelque obligation que ce soit. La présente publication peut aussi porter sur des caractéristiques susceptibles de ne pas être offertes dans certaines versions révisées du produit.

Marques de commerce

La présente publication peut contenir des références à des produits fabriqués ou offerts par d'autres entreprises. Les désignations des produits et des entreprises peuvent être des marques de commerce et appartiennent exclusivement à leurs propriétaires respectifs. AutomationDirect nie tout intérêt dans les autres marques et désignations.

**Copyright 2009-2010, 2016, 2018, Automationdirect.com™ Incorporated
Tous droits réservés**

Nulle partie de ce manuel ne doit être copiée, reproduite ou transmise de quelque façon que ce soit sans le consentement préalable écrit de la société Automationdirect.com™ Incorporated. AutomationDirect conserve les droits exclusifs à l'égard de tous les renseignements contenus dans le présent document.

Overview of this Publication

Thank you for purchasing a STRATUS Air Conditioner. This manual shows you how to install, program and maintain all STRATUS Air Conditioners in the series.

Who Should Read This Manual

This manual contains important information for those who will install, maintain, and/or operate any of the STRATUS Air Conditioners. It will provide the information you need to keep your system up and running.

Technical Support

By Telephone: 770-844-4200

(Mon.-Fri., 9:00 a.m.-6:00 p.m. E.T.)

On the Web: support.automationdirect.com

We strive to make our manuals the best in the industry. We rely on your feedback to let us know if we are reaching our goal. Our technical support group is glad to work with you in answering your questions. If you cannot find the solution to your particular situation, or, if for any reason you need additional technical assistance, please call technical support at **770-844-4200**. We are available weekdays from 9:00 a.m. to 6:00 p.m. Eastern Time.

We also encourage you to visit our web site where you can find technical and non-technical information about our products and our company. Visit us at www.automationdirect.com.

Special Symbols



When you see the “notepad” icon in the left-hand margin, the paragraph to its immediate right will be a special note.



When you see the “exclamation mark” icon in the left-hand margin, the paragraph to its immediate right will be a warning. This information could prevent injury, loss of property, or even death (in extreme cases).

Introduction

STRATUS air conditioning equipment is carefully designed to cool and dehumidify the air in electronic component enclosures. Use this guide as general instructions to properly install and operate the STRATUS air conditioning equipment. Read this guide completely before running or installing your STRATUS air conditioning equipment.

Prepare the enclosure that is to be cooled for mounting in accordance with this guide and the template supplied.

Preliminary tests must be performed before mounting or installing the air conditioner.

STRATUS air conditioning equipment must be mounted vertically with a minimum of 5” air space for condenser air return and supply.

Unpacking STRATUS Air Conditioning Equipment

Always keep air conditioner unit top up as shown by the packaging label and arrows. If the unit is to be transported after initial unpacking and inspection, place air conditioner back in original packing to prevent damage.

For shipment, repack as received and re-band to the pallet. Shipping without being strapped to the pallet may result in tipping and damage and voids the warranty.



Air conditioners are not designed to be shipped attached to an equipment enclosure. If this is required, the air conditioner must have sufficient support to prevent damage due to vibration and shock. Air conditioners damaged internally, due to being shipped attached to enclosures, are warranty voided.

What's in the box

Upon receipt of the STRATUS Air Conditioner, please check for the following:

- Make sure that the box contains all items required for installation of your series.
- Inspect the unit to ensure it was not damaged during shipment.
- Make sure that the part number indicated on the serial number label corresponds with the part number of your order.

Inspecting the Equipment

STRATUS air conditioning equipment is designed, manufactured and packed to prevent damage from normal handling, shock and vibration during shipment. Please be sure to inspect your equipment upon receipt to ensure that there is no visual or hidden damage.

Upon receipt of the equipment, ensure that it is always top side up as indicated by "THIS SIDE UP" labels; this ensures that the compressor oil is not displaced. If the equipment has been on its side, it must be put upright for at least 24 hours before installing or running to be certain the compressor oil has returned to the compressor. All physical damage to packing or signs of damage to the equipment must be noted on the freight bill of lading. Packages must be opened after receipt to inspect for any internal /concealed damage to the equipment and to verify proper count and order fulfillment. Shipments delivered without the pallet, not top-side up, other freight on top, damaged or wet should be refused delivery. Contact the shipper immediately upon discovery of shipping damage to schedule inspection by the freight company. Keep all packing. AutomationDirect cannot take responsibility for customer's failure to file freight damage claims on a timely basis.

1000 - 1500 BTU/Hour Models

- 1 Pre-bagged Hanger Bolt Kit includes (480V models — qty 2)
 - (8) - 10-32 x 1/2 Machine Screws/ Unslotted/ Indented Hex Washer Head, Steel/ Zinc
 - (8) - #10 Medium Split Lock Washer, Steel/Zinc
 - (8) - #10 Flat Washer/Machine Screw, Steel/Zinc
- Rubber Seal Gasket X-114HT Pre-Cut, QTY 6.5 feet. NEMA/UL Type 4 and 4X units have gasket installed
- Instruction / Operation Manual
- Actual Size Mounting Template

2000 - 4000 BTU/Hour Models

- 1 Pre-bagged Hanger Bolt Kit includes
 - (10) - 1/4 - 20 x 3/4 Machine Screws/ Unslotted/ Indented Hex Washer Head, Steel/Zinc
 - (10) - 1/4 Medium Split Lock Washers, Steel/Zinc
 - (10) - 1/4 Flat Washer/Machine Screw, Steel/Zinc
- Rubber Seal Gasket X-114HT Pre-Cut, QTY 8.5 feet. NEMA/UL Type 4 and 4X units have gasket installed
- Instruction / Operation Manual
- Actual Size Mounting Template

5000 - 8000 BTU/Hour Models

- 1 Pre-bagged Hanger Bolt Kit includes
 - (10) - 1/4 - 20 x 3/4 Machine Screws/ Unslotted/ Indented Hex Washer Head, Steel/Zinc
 - (10) - 1/4 Medium Split Lock Washers, Steel/Zinc
 - (10) - 1/4 Flat Washer/Machine Screw, Steel/Zinc
- Rubber Seal Gasket X-114HT Pre-Cut, QTY 10.0 feet. NEMA/UL Type 4 and 4X units have gasket installed
- Instruction / Operation Manual
- Actual Size Mounting Template

Nameplate Information

Be sure to record the data from the label onto the back of the manual and keep in a safe place for warranty.



WARNING: Before operating the air conditioner, inspect all electrical wiring to ensure proper installation and wiring to the proper power source. The minimum circuit amperage must be 125% of the air conditioner label amperage listed for the voltage selected.

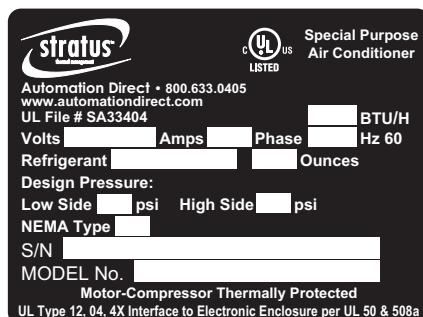

Input Specification
Refrigerant Type/Weight

Refrigerant Pressure
Enclosure Rating
A/C Unit Serial Number
A/C Unit Model Number

Basic Operation

The STRATUS air conditioner will lower the temperature inside an enclosure to ensure its proper operational temperature. STRATUS air conditioners, when sized properly, will provide cooling as necessary, automatically controlled through the digital temperature controller.

STRATUS air conditioners operate as a “closed loop” system where the enclosure air is taken into the STRATUS air conditioner and cooled, and then returned to the enclosure with no exposure to, or introduction of, outside / ambient air. This assures the enclosure is separated from, and not contaminated with, ambient air, dirt, chemicals, dust, moisture or foreign matter, so that sensitive enclosure components are protected and kept cool / dehumidified. The STRATUS air conditioner refrigeration cycle removes warm enclosure air and excess humidity. The humidity condenses to liquid and then the Condensate Removal System changes it back into vapor where it is then vented to the atmosphere. In the event of excess water where the enclosure door has been left open, there is an overflow hole on the bottom of every unit.

The evaporator fan runs continuously to provide the required climate control to the enclosure. The compressor turns on if the enclosure temperature is greater than the factory setpoint of 95°F plus the temperature differential of 5°F. As the refrigerant pressure builds to a factory setpoint, the condenser fan turns on to force air flow across the coils. Refrigerant low pressure and high temperature safety switches shut the compressor off if the evaporator coil begins to ice up, if there are leaks in the system, or if the condenser coil overheats. The temperature control display will indicate an LED alarm indication (!) and specific alarm, such as HA for high temperature alarm, or CA for low

pressure/low temperature alarm. After the compressor stops, most alarm conditions will resolve (pressure will equalize) and the snowflake LED on the temperature control will blink to indicate that the compressor is off for the five minute anti-short cycle time delay.

Refer to the Troubleshooting Guide for corrective action, as the condition may repeat in 7-minute cycles. For 2 minutes the alarm condition is bypassed to prevent nuisance trips. Then, there is a 5-minute, anti-short cycle time delay before the compressor is turned on.

The refrigerant thermal expansion valve assures optimum cooling efficiency through a wide range of operating temperatures. It requires no adjustment or maintenance.

STRATUS NEMA/UL type 4X stainless steel units and NEMA/UL type 4 units come with condenser coils coated with a cutting-edge, high efficiency, electrically applied, corrosion-resistant coating.

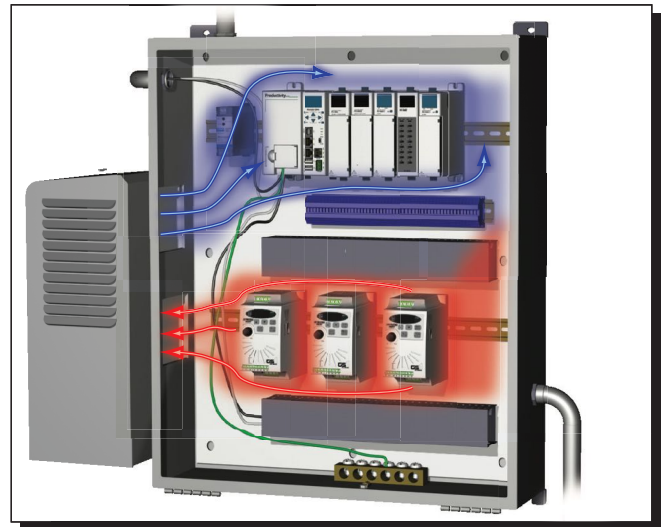

Closed Loop Cooling

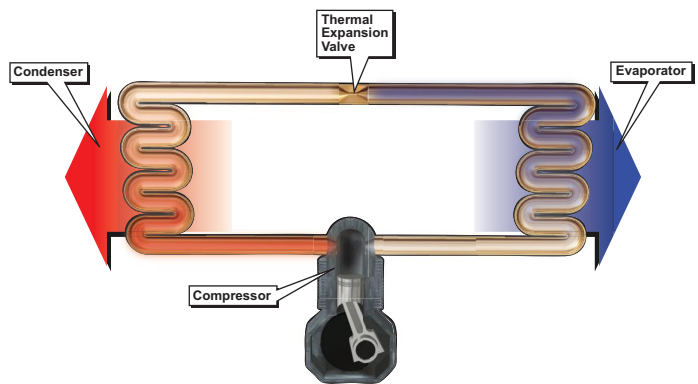
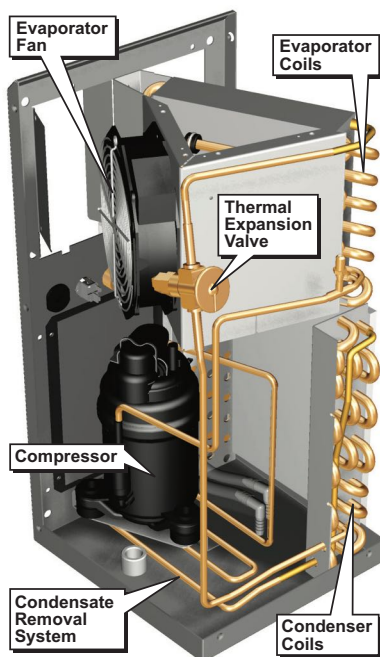

Refrigeration Cycle

Features

- Active Evaporator Condensate Boil-Off System
- High Condenser Refrigerant Temperature Control
- Low Refrigerant Pressure Cut-out Switch
- Digital Temperature Control Thermostat troubleshooting diagnostics
- Anti short-cycle Time Delay and Bypass Time Delay
- Condenser Fan Cut-in Control Pressure Switch
- Powder coated to prevent rust (NEMA/UL Type 12 and 4)
- Material: NEMA/UL Type 12, Type 4: 16-gauge cold rolled steel chassis and shroud

- NEMA/UL Type 4x: 304 stainless steel chassis and shroud
- Chassis and shroud seal system ensures closed loop air circulation
- Condenser inlet air filter
- Thermal expansion valve provides high performance over wide temperature range
- Internally insulated to minimize case heat loss
- Schrader valves on low AND high pressure service ports
- High efficiency performance = high BTU per KWH for minimal electricity cost
- Auxillary alarm contacts as a standard

Unit Specifications

NEMA Type 12 Unit Specifications								
Model	BTU/H @ Max. Ambient Temperature	Standard Max. Ambient Temperature	Volts/Hertz	Running Amps	Unit Weight (lb)	Refrigerant Type	Refrigerant Amt. (oz)	Typical Frame Size
TA10-010-16-12	1000	125°F (51.67°C)	115/60	3.44	51	R134a	4.00	1
TA10-010-26-12			230/60	2.67	53		4.00	
TA10-015-16-12	1500		115/60	3.44	51		7.75	
TA10-015-26-12			230/60	2.67	53		7.75	
TA10-020-16-12	2000	138°F (60°C)	115/60	6.818	66	R134a	14.00	2
TA10-020-26-12		125°F (51.67°C)	230/60	3.07	72	R422d	9.75	
TA10-020-46-12		138°F (60°C)	460/60	1.704	99	R134a	14.00	
TA10-040-16-12	3000 - 4000	125°F (51.67°C)	115/60	3.76	65	R422d	13.25	2
TA10-040-26-12			230/60	3.07	72		9.75	
TA10-040-46-12			460/60	0.94	99		13.25	
TA10-050-16-12	5000		115/60	7.26	97		12.50	3
TA10-050-26-12			230/60	3.76	92		12.50	
TA10-050-46-12			460/60	1.86	136		12.50	
TA10-060-16-12	6000 - 8000		115/60	7.83	97		18.00	3
TA10-060-26-12			230/60	4.80	98		18.00	
TA10-060-46-12			460/60	1.80	142		18.00	

* Voltage variation no greater than ± 10% from nameplate rating and Frequency variation no greater than ± 3Hz from nameplate rating.

Unit Specifications

NEMA Type 12 Unit Specifications								
Model	BTU/H @ Max. Ambient Temperature	Standard Max. Ambient Temperature	Volts/Hertz	Running Amps	Unit Weight (lb)	Refrigerant Type	Refrigerant Amt. (oz)	Typical Frame Size
TA10-010-16-12	1000	125°F (51.67°C)	115/60	3.44	51	R134a	4.00	1
TA10-010-26-12			230/60	2.67	53		4.00	
TA10-015-16-12	1500		115/60	3.44	51		7.75	
TA10-015-26-12			230/60	2.67	53		7.75	
TA10-020-16-12	2000	138°F (60°C)	115/60	6.818	66	R134a	14.00	2
TA10-020-26-12		125°F (51.67°C)	230/60	3.07	72	R422d	9.75	
TA10-020-46-12		138°F (60°C)	460/60	1.704	99	R134a	14.00	
TA10-040-16-12	3000 - 4000	125°F (51.67°C)	115/60	3.76	65	R422d	13.25	
TA10-040-26-12			230/60	3.07	72		9.75	
TA10-040-46-12			460/60	0.94	99		13.25	
TA10-050-16-12	5000		115/60	7.26	97		12.50	
TA10-050-26-12			230/60	3.76	92		12.50	
TA10-050-46-12			460/60	1.86	136		12.50	
TA10-060-16-12	6000 - 8000		115/60	7.83	97	18.00		
TA10-060-26-12			230/60	4.80	98	18.00		
TA10-060-46-12			460/60	1.80	142	18.00		

* Voltage variation no greater than $\pm 10\%$ from nameplate rating and Frequency variation no greater than $\pm 3\text{Hz}$ from nameplate rating.

NEMA Type 12 Unit Specifications								
Model	BTU/H @ Max. Ambient Temperature	Standard Max. Ambient Temperature	Volts/Hertz	Running Amps	Unit Weight (lb)	Refrigerant Type	Refrigerant Amt. (oz)	Typical Frame Size
TA10-010-16-12	1000	125°F (51.67°C)	115/60	3.44	51	R134a	4.00	1
TA10-010-26-12			230/60	2.67	53		4.00	
TA10-015-16-12	1500		115/60	3.44	51		7.75	
TA10-015-26-12			230/60	2.67	53		7.75	
TA10-020-16-12	2000	138°F (60°C)	115/60	6.818	66	R134a	14.00	2
TA10-020-26-12		125°F (51.67°C)	230/60	3.07	72	R422d	9.75	
TA10-020-46-12		138°F (60°C)	460/60	1.704	99	R134a	14.00	
TA10-040-16-12	3000 - 4000	125°F (51.67°C)	115/60	3.76	65	R422d	13.25	
TA10-040-26-12			230/60	3.07	72		9.75	
TA10-040-46-12			460/60	0.94	99		13.25	
TA10-050-16-12	5000		115/60	7.26	97		12.50	
TA10-050-26-12			230/60	3.76	92		12.50	
TA10-050-46-12			460/60	1.86	136		12.50	
TA10-060-16-12	6000 - 8000		115/60	7.83	97	18.00		
TA10-060-26-12			230/60	4.80	98	18.00		
TA10-060-46-12			460/60	1.80	142	18.00		

* Voltage variation no greater than $\pm 10\%$ from nameplate rating and Frequency variation no greater than $\pm 3\text{Hz}$ from nameplate rating.

Preliminary Testing

Before installing the STRATUS system on the enclosure, operate the unit for 20 to 30 minutes to ensure it is functioning properly. Although the unit has been tested at the factory, internal damage, which may have not been apparent during the unpacking inspection, may have occurred during shipping, .

- Place the system on a solid base, such as a workbench or table.
- 1000 and 1500 BTU/H units draw external cooling air from the bottom and must be operated elevated.
- Check that the warm air system filter is in place. Location varies with model - see dimensional drawings.
- Check the serial number label to be sure the electric power available to the air conditioner is the proper voltage, phase and amperes.
- Check electric power source for proper ground wire and neutral wire installation.
- Check to verify that the electric power is protected by an appropriately sized fuse or circuit breaker.
- As soon as power is supplied to the system, the cool air evaporator fan will begin to operate. The compressor and warm air condenser fan will not operate if the room air temperature is below 100°F. This is because the programmable controller has a factory setpoint of 95°F plus 5°F differential parameter (Hy). The digital display on the face of the controller will be displaying room temperature. If the display indicates 100°F or warmer, the snowflake status LED will display and the compressor will operate. The warm air condenser fan will come on shortly after the compressor, when the refrigerant pressure builds to approximately 300 psi. If the display indicates a temperature less than 100°F, adjust the setpoint to a temperature lower than the room temperature in order for the compressor and warm air condenser fan to operate. Refer to the Digital Temperature Controller section of this manual in order to change the factory setpoints.
- With the compressor and both fans functioning, allow the unit to operate for 20 to 30 minutes. This will provide sufficient time for the vapor compression system to achieve equilibrium. Measure the cool air outlet temperature with an accurate thermometer. This temperature should be at least 10 degrees colder than the inlet air temperature (if the room temperature is warmer than 70°F). Inlet air temperature will be displayed on the programmable controller. In areas of high humidity, the temperature difference may be less than 10 degrees.

Note: Turn the unit off if any of the equipment makes any unexpected or hard mechanical noises or vibrations, and refer to the Troubleshooting Guide.

Note: If the Digital Temperature Controller displays any alarms, refer to the Digital Temperature Controller section.

- After completing the above check points, the electrical enclosure is ready to be prepared for the installation of the STRATUS AC unit.

Mounting the Air Conditioner



Caution: To prevent damage to the coils, use **ONLY** the mounting bolts provided with the unit.

Using the template supplied, determine where the air conditioner is to be mounted and make sure that all required cuts and holes will not interfere with or damage the enclosure. There must be 5" clearance between walls / obstructions and the air conditioner so as not to restrict the condenser supply air and return air flow. Restricted condenser air flow will affect the air conditioner's performance.



Caution: If mounting the air conditioner to the enclosure door, confirm with the enclosure manufacturer that the door's hinges will support the air conditioner's added weight (see equipment specifications). Ensure that when the door is fully open, that the enclosure will not topple over due to the off-center load.

Mount the air conditioner high on the enclosure in order to cool the hot air in the top of the enclosure. Position the unit where the cold air can circulate across the width of the enclosure to cool it all the way across.

Once proper mounting placement is determined, turn the enclosure equipment off, if possible, to prevent damage. Drill and cut the holes as indicated on the actual size mounting template included in the package. Install insulation gasket as required to ensure an air-tight closed-loop seal. Hang the air conditioner on the Easy Hang tabs.

From inside the enclosure, use the fasteners supplied to attach the air conditioner to the enclosure. Tighten the bolts in stages so that there is equal pressure at all points of attachment. Ensure that these fasteners are tight so as to prevent the unit from falling off the enclosure. These fasteners should be checked periodically to be sure that they have not become loose because of vibration.

Verify that the power supplied is compatible with the air conditioner's power requirements provided on the air conditioner serial number label. Properly connect to a circuit with a minimum 15 amp capacity circuit breaker and proper voltage and frequency. Please check the specification label on the unit for exact amp rating. Test the voltage at the power source for proper polarity and good ground.

After mounting the air conditioner, replace / close the enclosure door and start air conditioner; test for air leaks to assure a proper closed air loop seal, and run-test the unit to assure proper operation after mounting. If any cold air leaks are found, check for proper mounting and apply silicone-free Lexel sealer if leaks persist. Check that the air conditioner's condenser inlet air filter is installed properly and make sure it is cleaned regularly.

System Operation

Once the STRATUS system has been installed onto the enclosure and the power has been connected to a properly grounded power source with adequate voltage and current supply, the unit is ready for operation. As soon as electrical power is supplied to the STRATUS system and the power switch located on the back of the unit is turned on, the evaporator fan will start to operate. The fan will run continuously so that the controller can monitor the enclosure's internal temperature. The enclosure temperature will be displayed on the face of the controller. If the enclosure temperature is greater than the cooling setpoint of 95°F plus factory-set temperature differential of 5°F, the snowflake status LED will be ON and the compressor will turn on. After the refrigerant pressure builds up to a factory setpoint of 300 psi, the condenser fan will operate.

This signifies that the cooling system has begun operation to remove heat and humidity from the enclosure. If the heat load within the enclosure is less than the cooling capacity of the STRATUS system, the temperature on the digital display will begin to drop. When the temperature inside the enclosure drops to the factory-set 95°F setpoint, the compressor will cycle off. The cool air evaporator fan will continue to operate, circulating air within the enclosure. The compressor fan will cycle off if the pressure drops below the factory setpoint.

**Example: "Cooling on" @ 100°F; "Cooling off" @ 95°F.
Set point is 95°F plus 5°F Hysteresis= Cooling on @ 100°F.**

If the compressor attempts to cycle within 5 minutes, the snowflake status LED will FLASH. This indicates that the compressor's automatic timer is working (the anti-short-cycle timer is factory set at 5 minutes). At the end of 5 minutes, the compressor will begin to operate and the snowflake status LED will remain ON while the compressor remains on.

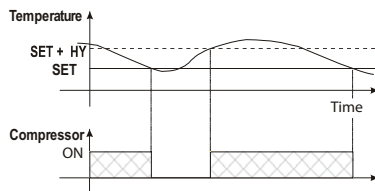

System Faults

If any of the critical control parameters exceed limits, the compressor is turned off, an alarm condition is indicated on the front panel, and an alarm contact (Form C) operates for remote alarming.

Three main conditions can shut down the AC compressor down:

- The condenser high temperature alarm
- The evaporator coil alarm
- The compressor thermal overload

In the event that the condenser coil overheats, a condenser high temperature alarm, **HA2**, will flash on the display of the digital temperature controller, the remote alarm contact will operate, and the compressor will turn off after a 3-minute time delay.

In the case that the evaporator coils ice up or there is a leak, an evaporator coil alarm, **CA**, will flash on the display of the Digital Temperature Controller, the remote alarm contact will operate, and the compressor will turn off after a 2-minute time delay.

A thermal overload protects the compressor against faults. In the event that the snowflake status LED is not flashing on the display and the compressor is not running, an internal fault may have occurred on the unit. Refer to the Troubleshooting Guide in this manual.

Alarm Conditions

If any of the alarm parameters exceed limits, an alarm condition is indicated on the front panel and an alarm contact (Form C) operates for remote alarming.

The temperature alarms are delayed for 30 minutes at initial startup. If the preset high temperature limit is exceeded for more than 3 minutes, the compressor continues to operate but there is a maximum temperature alarm, **HA**, flashing on the display.

If the preset low temperature limit of 45°F is exceeded for more than 3 minutes, there is a minimum temperature alarm, **LA**, flashing on the display. (The compressor turns off at the temperature setpoint.)

In case of a fault in the enclosure temperature probe "P1", the start and stop of the compressor are delayed for 5 and 15 minutes, respectively. A **P1** alarm will display and the remote alarm contact will operate immediately.

In case of a fault in the condenser temperature probe "P2", a **P2** alarm will flash on the display and the remote alarm contact will operate immediately.

If the evaporator coil pressure drops below 10 psi for more than 2 minutes, there is an evaporator coil alarm, **CA**, and the compressor turns off. After the pressure is increased to 25 psi, the **CA** alarm is cleared and the compressor operates after a 5-minute time delay.

Digital Temperature Controller



Overview

The microprocessor-based digital temperature controller performs the functions of controlling the enclosure temperature while monitoring operating limits and refrigerant pressures. Temperature and alarm status are indicated on the front panel in easy-to-read LEDs (0.57”x 0.29” [14.5mm x 7.3mm]). It also records the maximum and minimum temperatures within the enclosure.

The controller includes a compressor anti short-cycle time delay (Parameter AC = 5 minutes) for compressor protection. A factory-set bypass time delay of 2 minutes prevents nuisance trip-outs caused by cold weather startups and transient high temperature limits.

The inputs include one enclosure temperature probe (NTC input), one condenser coil temperature probe (NTC input) and one low pressure switch digital input. Select parameters (listed in the setpoint table) are configurable through the keypad.

FRONT PANEL COMMANDS

Front Panel Commands		
Symbol	Visual Mode	Programming Mode
SET	To display target setpoint in memory. Hold >2 sec to enter Programming Mode	Selects or confirms an operation
▲	(UP): To display maximum temperature setpoint in memory	Displays parameters or increases value
▼	(DOWN): To display minimum temperature setpoint in memory	Displays parameters or decreases value

KEY COMBINATIONS

▲ + ▼	To lock and unlock the keyboard
SET + ▲	To return to the room temperature display
SET + ▼	To enter programming mode

LED FUNCTIONS

LED Functions		
LED	MODE	FUNCTION
❄️	ON	Compressor enabled
❄️	Flashing	Anti short-cycle delay enabled
🔊	ON	An alarm is occurring (CA or HA)
°F	ON	Measurement unit
°F	Flashing	Programming phase

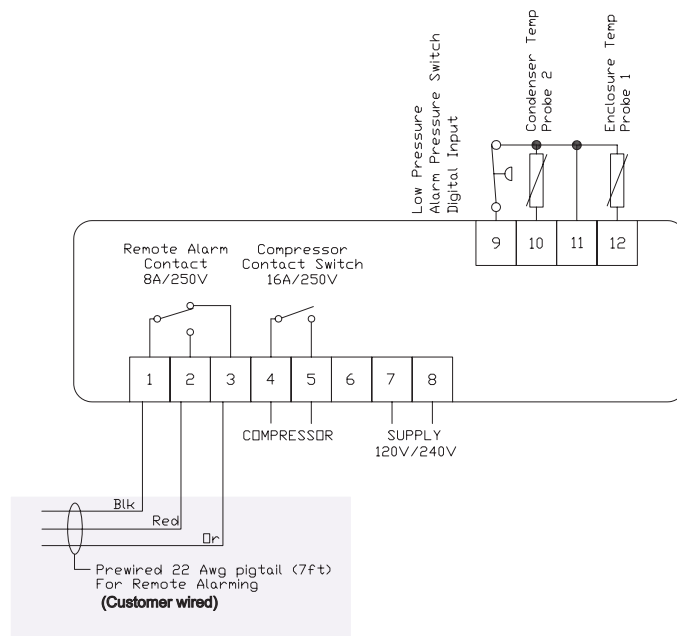

Functions and Parameters

Temperature Controller Setpoints

Function	Operation	Parameter	Operating Range	Factory Set Point
Cooling Setpoint	Set cooling relay	SET	70 to 95°F	95°F
Cooling Differential	Control hysteresis	Hy	1 to 45°F	5°F
Compressor Protection	Anti short-cycle	AC	0 to 50 minutes	5 minutes
*Probe Displayed	Selects display probe P1 - Enclosure Temp P2 - Condenser Temp	Lod	P1, P2, P3, P4	P1
Max Temp Alarm	Panel Indicator	ALU	45 to 302°F	105°F
Min Temp Alarm	Panel Indicator	ALL	-67 to 105°F	45°F

**Note: P3 and P4 are not used and if selected will result in noP flashing on the display.*

Main Functions

HOW TO SEE THE SETPOINT

-  SET
1. Press and immediately release the **SET** key. The display will show the setpoint value.
 2. Press and immediately release the **SET** key or wait for 15 seconds to display the probe value again.

HOW TO CHANGE THE SETPOINT

1. Press the **SET** key for more than 2 seconds to change the setpoint value.
The value of the setpoint will be displayed and the **F** LED starts blinking.
 2. To change the **SET** value, press the **UP** or **DOWN** arrow key within 15 seconds.
 3. To store the new setpoint value, press the **SET** key again or wait 15 seconds.
- NOTE: The set value is stored even when the procedure is exited by waiting for the time-out to expire.*

HOW TO CHANGE THE DIFFERENTIAL VALUE (Hy)

To change the parameter's value, operate as follows:

1. Enter the Programming mode by pressing the **SET + DOWN** arrow keys for 3 seconds. The **F** LED starts blinking.
2. Select the required parameter by pressing the **UP** or **DOWN** arrow key. Press the **SET** key to display its value.
3. Press the **UP** or **DOWN** arrow key to change its value.
4. Press **SET** to store the new value and move to the following parameter.

To exit: Press **SET + UP** arrow keys or wait 15 seconds without pressing a key.

NOTE: The set value is stored even when the procedure is exited by waiting for the time-out to expire.

HOW TO CHANGE THE AC, Lod, ALU AND ALL PARAMETERS

1. Press and hold the **SET and DOWN** arrow keys simultaneously for more than 3 seconds. (The °F LED starts blinking.)
2. Release the keys, then push the **SET and DOWN** arrow keys simultaneously, again for more than 7 seconds.
The **Pr2** label will be displayed immediately followed by the **HY** parameter.
3. Select the required parameter.
4. Press the **SET** key to display its value.
5. Press the **UP** or **DOWN** arrow to change its value.
6. Press **SET** to store the new value and move to the following parameter.

To exit: Press **SET + UP** arrow keys or wait 15 seconds without pressing a key.

NOTE 1: If no parameter is present in Pr1, after 3 seconds the noP message is displayed. Keep the keys pushed until the Pr2 message is displayed.

NOTE 2: The set value is stored even when the procedure is exited by allowing the time-out to expire.

HOW TO LOCK THE KEYBOARD

1. Press and hold the **UP** and **DOWN** arrow keys simultaneously for more than 3 seconds.
2. The **POF** message will be displayed and the keyboard will be locked.
At this point, it will be possible only to see the setpoint or the MAX or MIN temperature stored.
If a key is pressed for more than 3 seconds the **POF** message will be displayed.

HOW TO UNLOCK THE KEYBOARD

1. Press and hold the **UP** and **DOWN** arrow keys simultaneously for more than 3 seconds until the **Pon** message is displayed.

Functions and Parameters

Maximum and Minimum Temperature

HOW TO SEE THE MINIMUM TEMPERATURE

1. Press and release the **DOWN** arrow key.
The **Lo** message will be displayed followed by the minimum temperature recorded.
2. By pressing the **DOWN** arrow key again or waiting 5 seconds, the normal display will be restored.

HOW TO SEE THE MAXIMUM TEMPERATURE

1. Press and release the **UP** arrow key.
The **Hi** message will be displayed followed by the maximum temperature recorded.
2. By pressing the **UP** arrow key again or waiting 5 seconds, the normal display will be restored.

HOW TO RESET THE MAX AND MIN TEMPERATURE RECORDED

1. Press and hold the **SET** key for more than 3 seconds, while the maximum or minimum temperature is displayed. (**rSt** message will be displayed)
2. To confirm the operation, the **rSt** message will blink and the normal temperature will be displayed.

ALARM SIGNALS

Alarm Signals		
Message	Cause	Outputs
P1	Enclosure probe failure	Alarm relay operates; start and stop of the compressor after 15-minute intervals
P2	Condenser probe failure	Alarm relay operates
HA	Maximum temperature alarm: P1 > 105°F for 3 minutes (after initial 30 min. delay)	Alarm relay operates
LA	Minimum temperature alarm: P1 < 45°F for 3 minutes (after initial 30 min. delay)	Alarm relay operates
HA2	Condenser high temperature: P2 > 145°F for 3 minutes	Alarm relay operates, compressor off
LA2	Condenser low temperature: P2 < 50°F for 3 minutes	Alarm relay operates
CA	Evaporator coil alarm: low pressure for 2 minutes	Alarm relay operates, compressor off
noP	Invalid probe selected: low evaporator coil	No outputs, display only

ALARM RECOVERY

If the compressor is turned off due to an alarm, it will be able to restart after the **AC** anti short-cycle time delay. (Parameter AC = 5 minutes)

Probe alarm **P1** is cleared with no time delay after the fault is cleared.

Probe alarm **P2** starts and stops with no time delay.

Temperature alarm **HA** automatically clears as soon as the temperature returns to below 105°F (the **ALU** setpoint) - 2°F = 103°F.

Temperature alarm **LA** automatically clears as soon as the temperature returns to above 45°F (the **ALL** setpoint) + 2°F.

Temperature alarm **HA2** automatically clears as soon as the condenser coil temperature returns to below 135°F.

Temperature alarm **LA2** automatically clears as soon as the condenser coil temperature returns to above 60°F

Temperature alarm **CA** automatically clears as soon as the pressure returns to normal.

Preventative maintenance



Before performing any maintenance, turn off power to the unit.

Air conditioners require regular cleaning of the condensing air inlet filter. Wash the filter often, and back-flush the dirt out; or replace, if not washable, whenever it appears physically dirty. Restriction to the flow of air over the condenser coil will degrade the performance of the equipment, cause it to overheat, reduce cooling and can damage the compressor. The compressor protection system will cycle the unit off if the condenser temperature is too high or the compressor is otherwise overloaded.

Restricted air flow due to neglecting a dirty filter will cause the unit to safety off and then turn back on after it cools off, over and over (cycling). Operation in this overheat/shut down/cool down/restart mode will damage the equipment and void the warranty.

Air Filter Service



Before performing any maintenance, turn off power to the unit.

Remove the air conditioner filter and wash, or replace if not washable. Dry thoroughly before replacing. Order replacement filters by frame size (TA10-FILTER-1, TA10-FILTER-2 or TA10-FILTER-3) from AutomationDirect. DO NOT operate the air conditioner without the air filter. Such operation will allow the condensing coil to become dirty and lose efficiency, causing overheating and diminished cooling capacity. Dirty condensing coils must be back-flush cleaned using proper commercial coil cleaning compounds and thorough back-flush rinsing. Refer to directions on the cleaning compounds selected. Acid wash is not recommended as it reduces the life of the coil.



Note: Do not use solvents to clean the programmable thermostat. Wipe with mild soap and water.

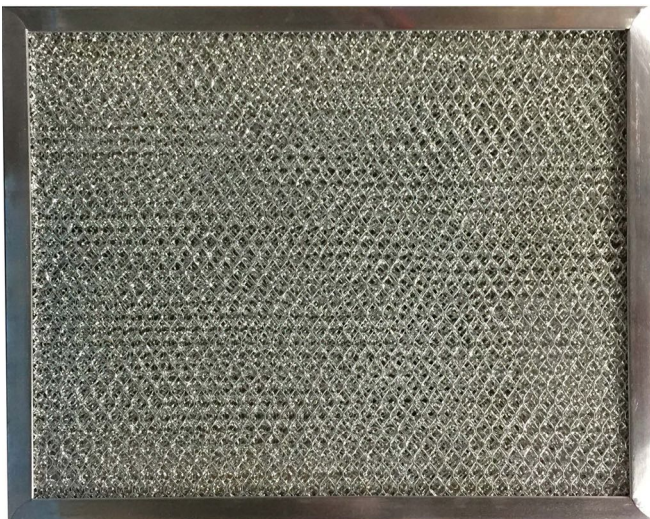

Replacement filters are available (purchase separately) for each of the three Stratus air conditioner frame sizes.

Condenser and Evaporator Fans:

STRATUS air conditioners use high efficiency, long life (high duty cycle), high tech, ball bearing fans engineered for optimum performance. The bearings are sealed and require no maintenance. Keep fan blades clean for optimal performance. Before performing any maintenance, turn off power to the unit. Fans are removable and powered through plug-in connections.

Compressor

STRATUS uses hermetically factory sealed compressors that are quiet, low vibration and are maintenance-free. Overheat sensors are installed to protect the compressor from damage due to overheating.

Note: The rotary compressor runs with compressed refrigerant gas on the outer case and therefore is hot to the touch.



STRATUS air conditioners are meticulously leak-tested and run-tested after assembly. If a leak in the system should develop due to shipping damage or mechanical vibration, the leak must be detected, repaired and the refrigerant charge restored to the system by a qualified refrigeration professional.

Moving the Enclosure and the Air Conditioner

If the enclosure the STRATUS air conditioner is mounted to must be moved, remove the air conditioner from the enclosure and move the air conditioner and enclosure separately. Moving an enclosure with the air conditioner mounted may damage the enclosure and the air conditioner and void the warranties.

Troubleshooting Guide

TROUBLESHOOTING GUIDE			
COMPLAINT	SYMPTOM	PROBABLE CAUSE	ACTION
Unit will not run	Controller not on Evaporator fan not on	No power	Check circuit breaker. Check voltage at power source. Power must match unit requirements, 15 Amps min.
		Unit power switch off	Check rocker switch inside panel.
Compressor stalls on startup	Compressor hums for 3 -5 seconds then trips	Insufficient power under load	Check power source, wiring and circuit breaker capacity using power quality meter.
		Defective or disconnected run capacitor	Have qualified A/C tech test and replace.
	CB on overload	Faulty compressor	Have qualified A/C tech test winding impedance. Replace compressor if defective.
		Controller on	LED/Snowflake not on
	Evaporator fan not running	LED/Snowflake blinking	Unit off on anti-short cycle time delay - clears after 5 minutes.
		Defective evaporator motor	Have qualified A/C tech clean, repair or replace.
	Evaporator running CA alarm displayed	Setpoint too low	Adjust temperature setpoint.
		Low ambient	Warm unit/Install low ambient crankcase heater.
Evaporator coil frozen		Thaw and clean coil. Check for clogged drain. If enclosure obstruction causing air re-circulation, remove obstruction.	
Low refrigerant		Have qualified A/C tech check.	
Unit runs but does not cool properly	Compressor cycling	Cycling on set point	Reprogram setpoint or increase Hy.
		Dirty condenser	Clean condenser coil.
	HA2 alarm intermittent	Condenser air flow blocked	Installation must meet minimum clearance for condenser air flow.
		Adjacent unit heating air	Install baffle/deflector or move unit(s).
		Good condenser	Have qualified A/C tech check evaporator section.
	Perform touch test: Compressor hot (190°F) Suction accumulator cold (50 to 65°F)	Restricted air flow	Clean evaporator.
Recirculating air flow		Remove restriction/Install baffle/Install fan.	
Unit vibrating or noisy	Noise	Possible freight damage	Inspect all points of mechanical contact between tubing and shroud or chassis.
		Tube rattling against shroud	
		Compressor rattling against shroud	Inspect compressor mounting.
		Foreign object in fan/blower	Clean blowers; tie-wrap any loose wiring. Replace air filter to prevent recurrence.
		Broken or bent fan blade	Replace blower unit or fan blade.
High refrigerant pressure due to dirty air filter, blocked or recirculating condenser air flow or dirty condenser	Test air temperature entering and leaving condenser. Entering should equal ambient. Leaving should equal entering + 15 degrees. Clean condenser with degreaser and low pressure rinse. Clean or replace filter.		
Condensate draining from overflow	Drains during normal operation	Door partially open or air leaks between unit and enclosure	Check door gasket and gasket compression on closing. System must be closed loop.
Condensate draining inside unit	Water leaking out around compressor	Blockage in evaporator drain lines prevents water getting to the boil-off pan.	Clean condensate drains with degreaser. Check for crushed or blocked drain lines. Clean evaporator coil and check for source of contamination.
		Defective evaporator blower	Have qualified A/C tech clean, repair or replace.
	Iced-up evaporator coil	Low refrigerant	Have qualified A/C tech check level.

Dimensions

Typical Frame Size 1 1000 and 1500 BTU/H Units

All dimensions inches [millimeters]

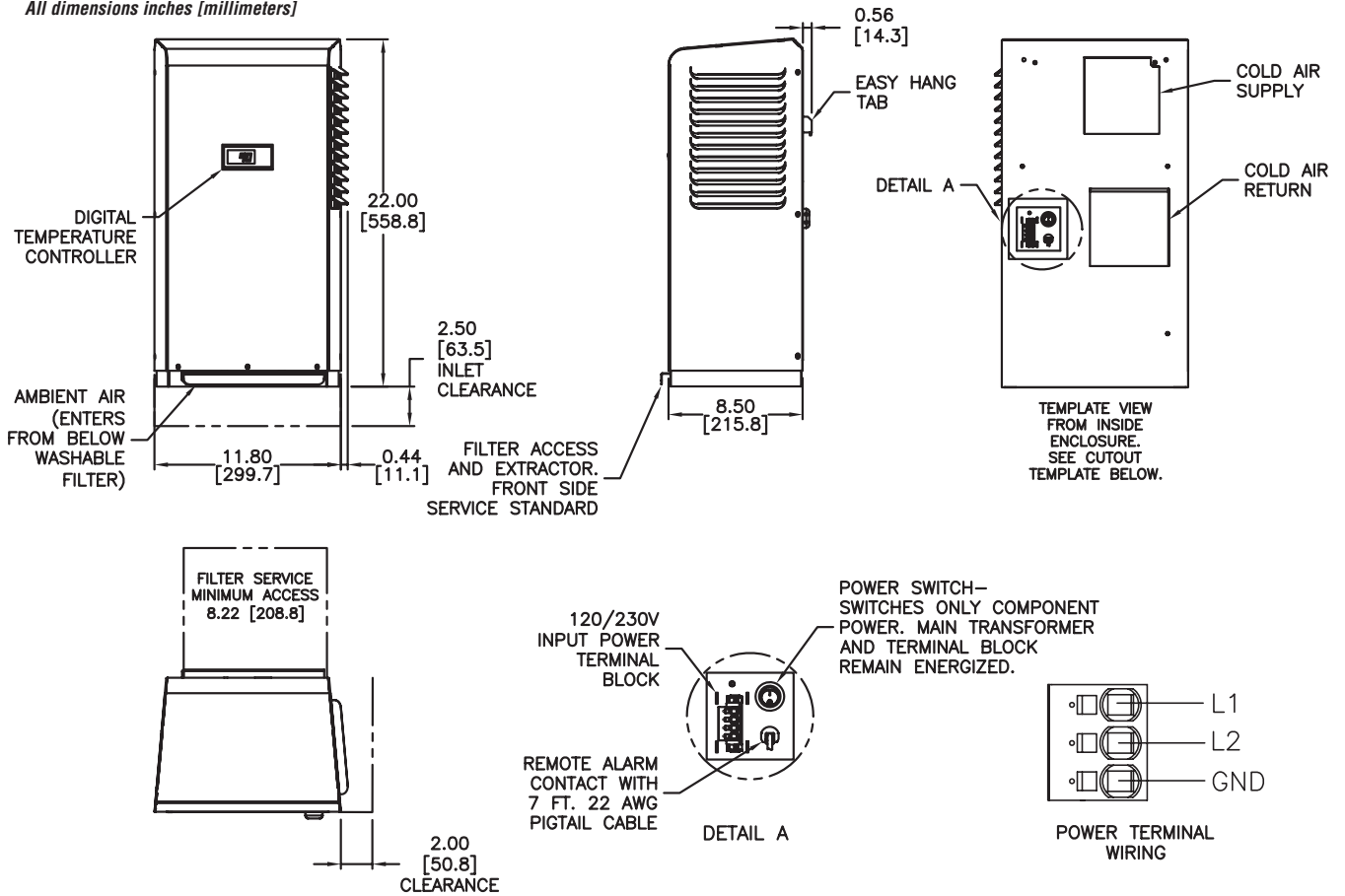

Wiring

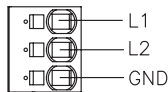

POWER TERMINAL WIRING



ALARM CONTACT WIRING

Dimensions

Cutout for Typical Frame Size 1 1000 and 1500 BTU/H Units

All dimensions inches [millimeters]

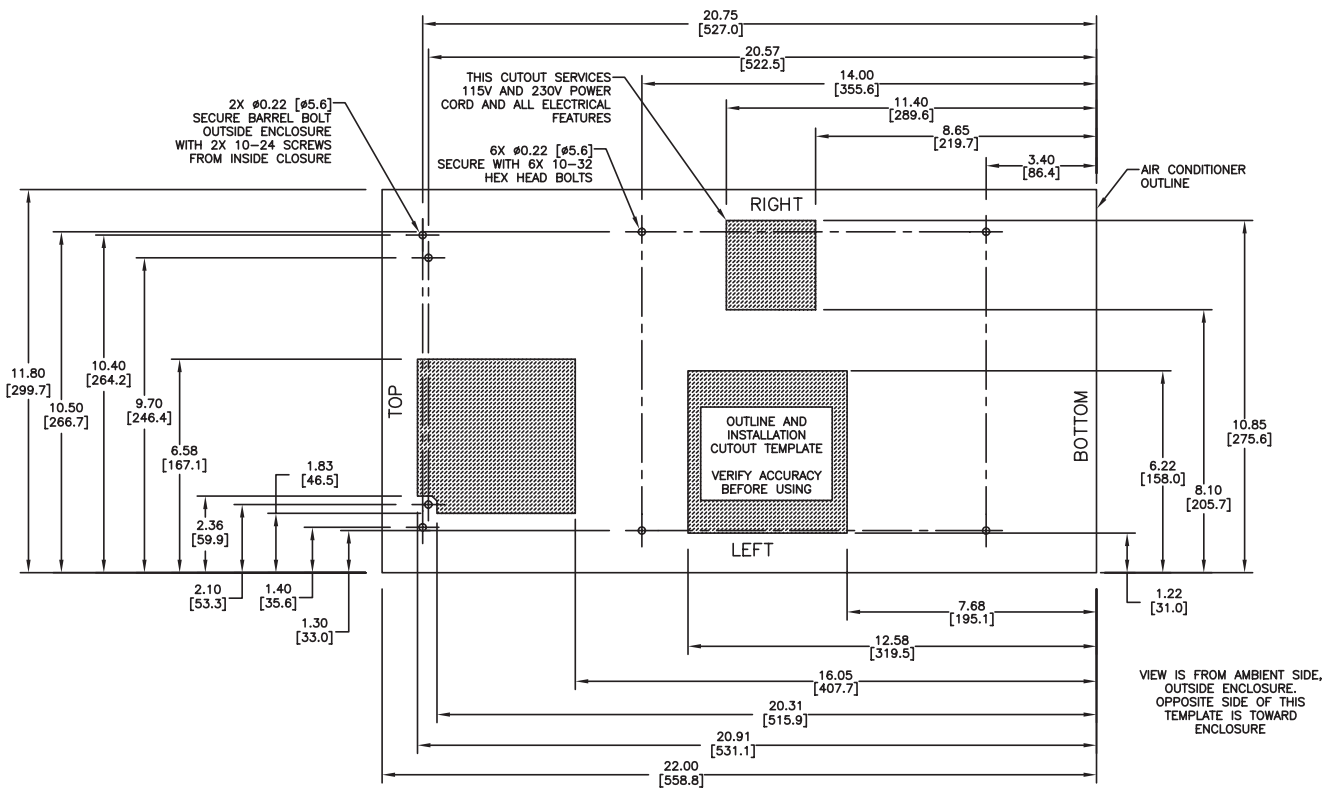

Dimensions

Typical Frame Size 2 2000 and 3000 - 4000 BTU/H Units

All dimensions inches (millimeters)

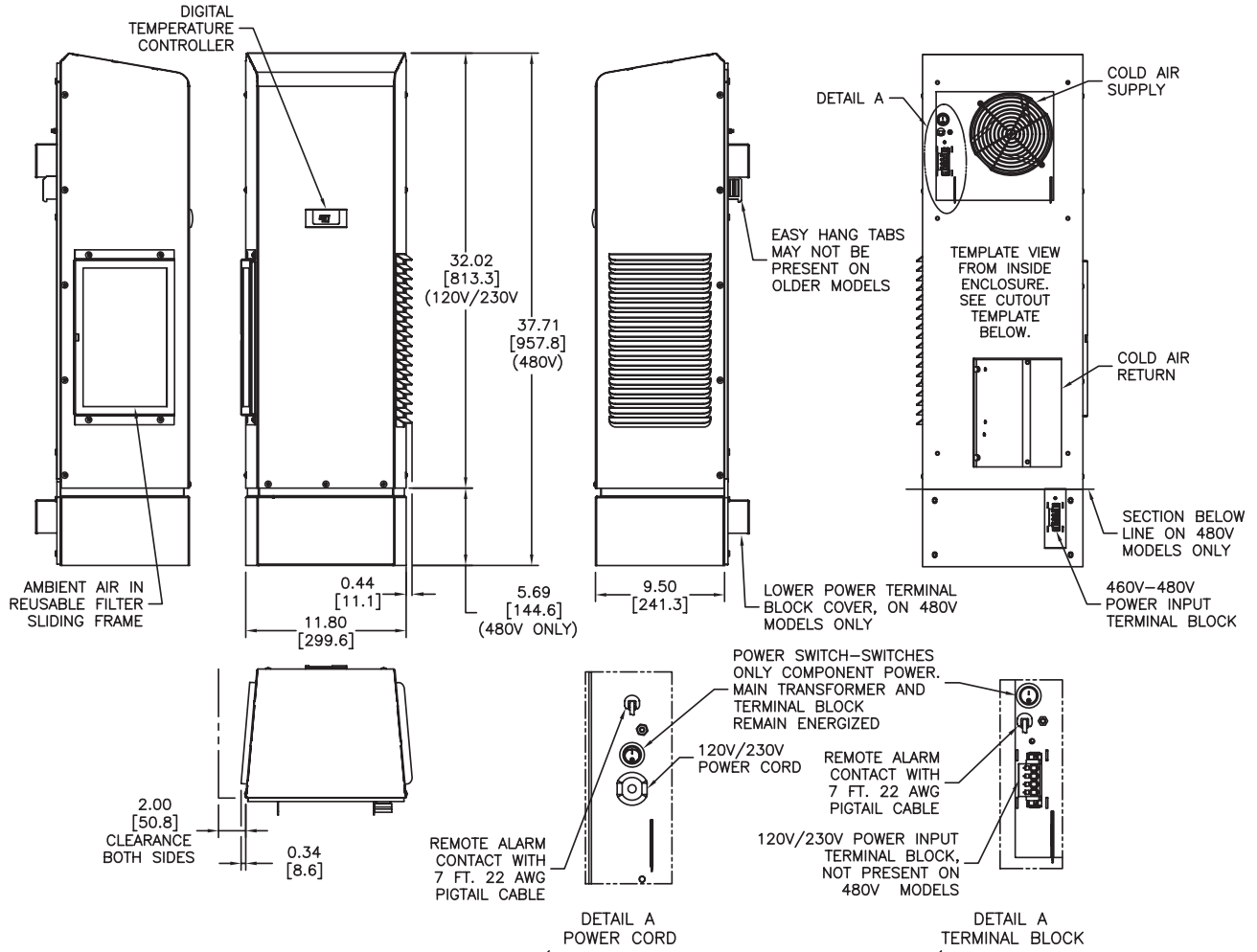

Wiring

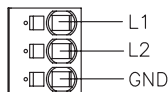

POWER TERMINAL WIRING



ALARM CONTACT WIRING

Dimensions

Cutouts for Typical Frame Size 2 2000 and 3000 - 4000 BTU/H Units

All dimensions inches [millimeters]

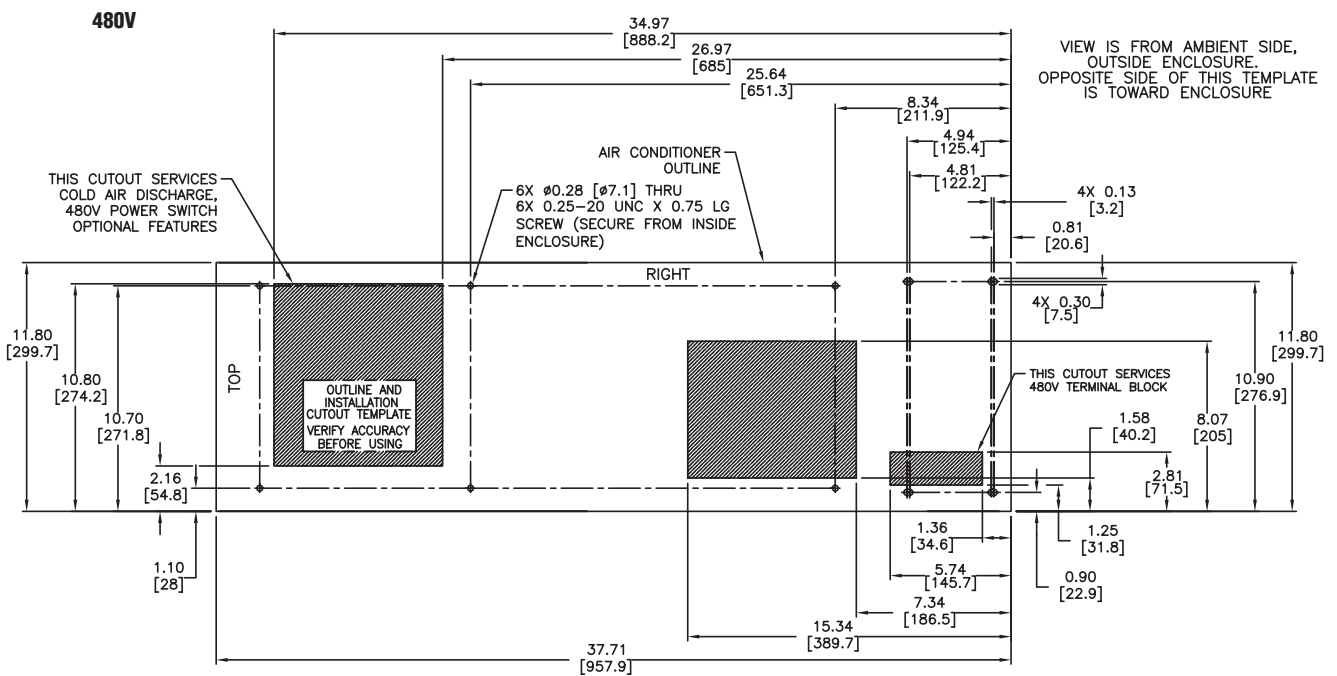
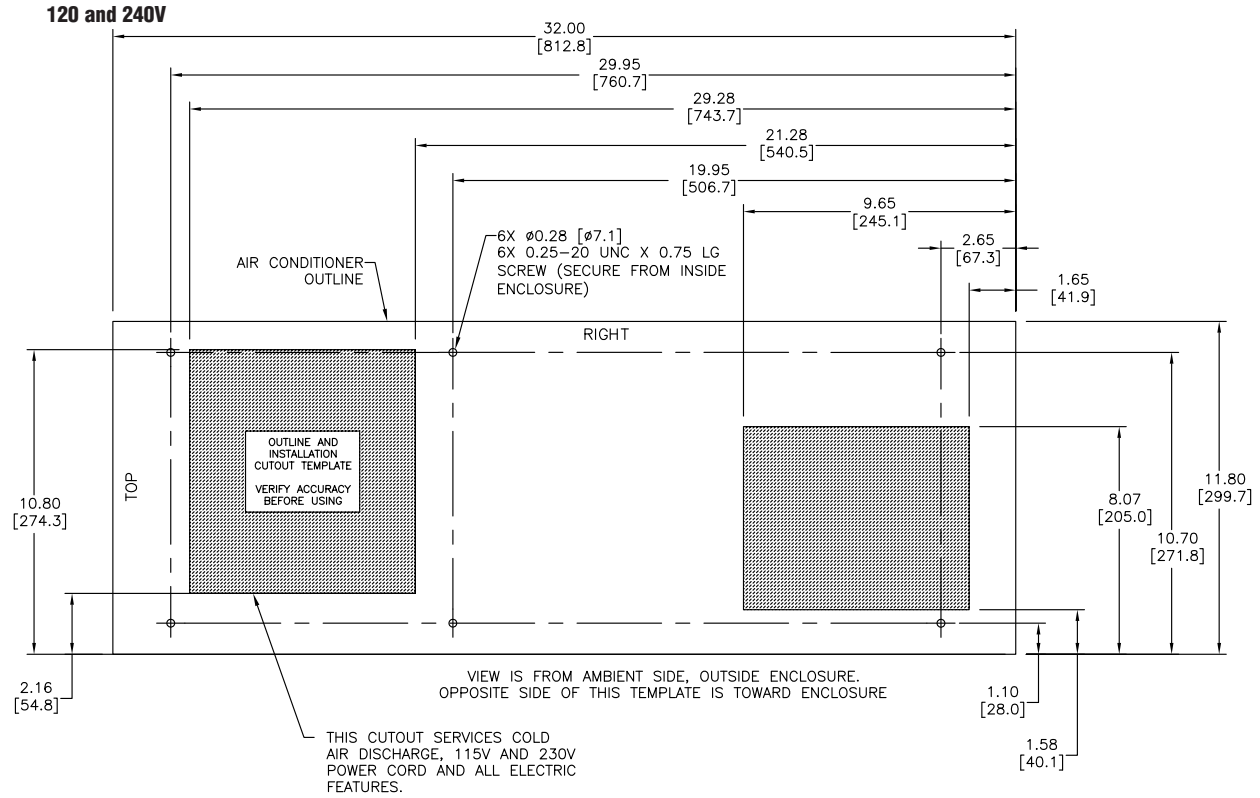

Dimensions

Typical Frame Size 3 5000 and 6000 - 8000 BTU/H Units

All dimensions inches [millimeters]

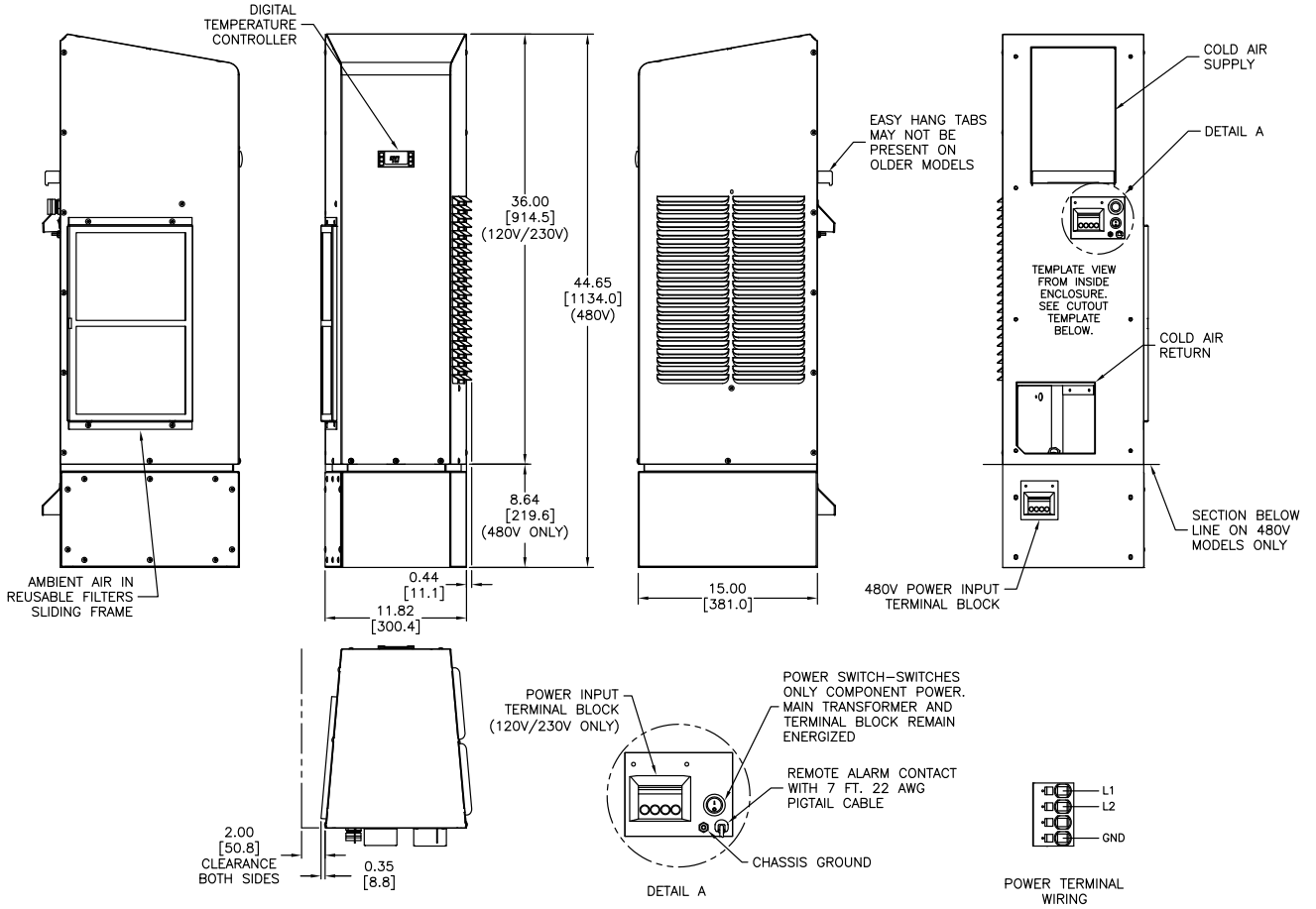

Wiring

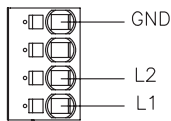

POWER TERMINAL WIRING

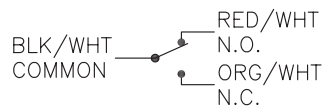

ALARM CONTACT WIRING

Dimensions

Cutouts for Typical Frame Size 3 5000 and 6000 - 8000 BTU/H Units

All dimensions inches [millimeters]

120 and 240V

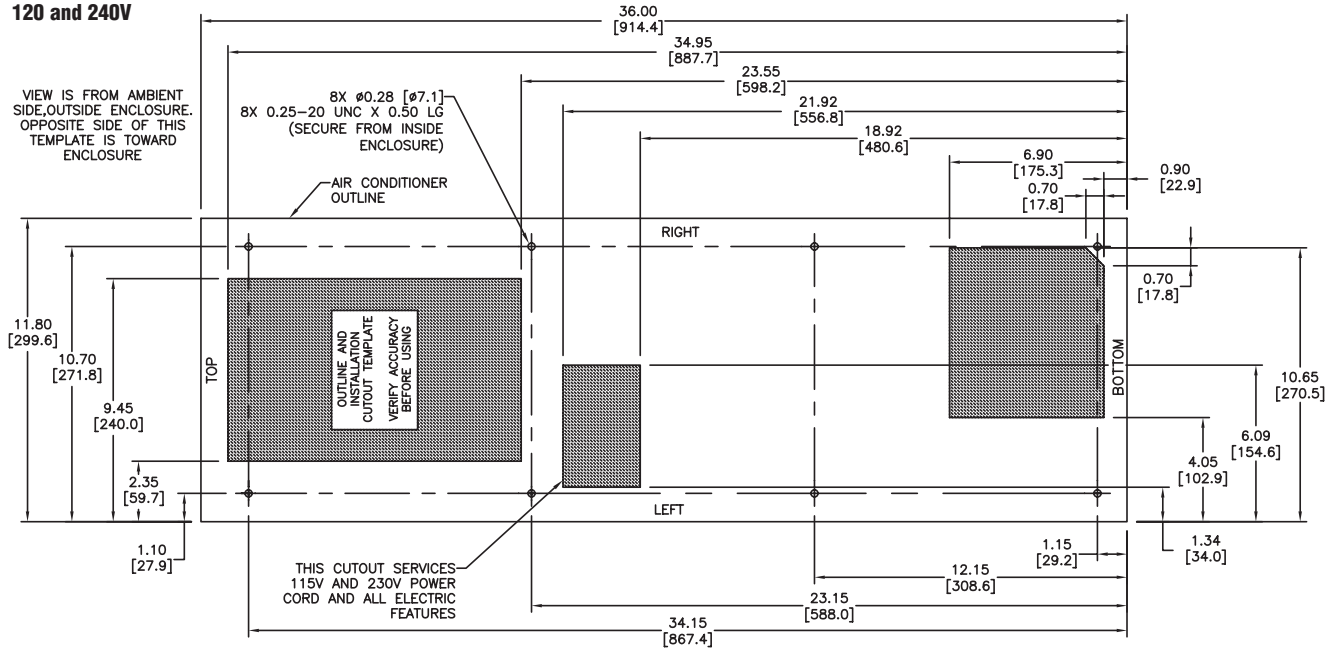

480V

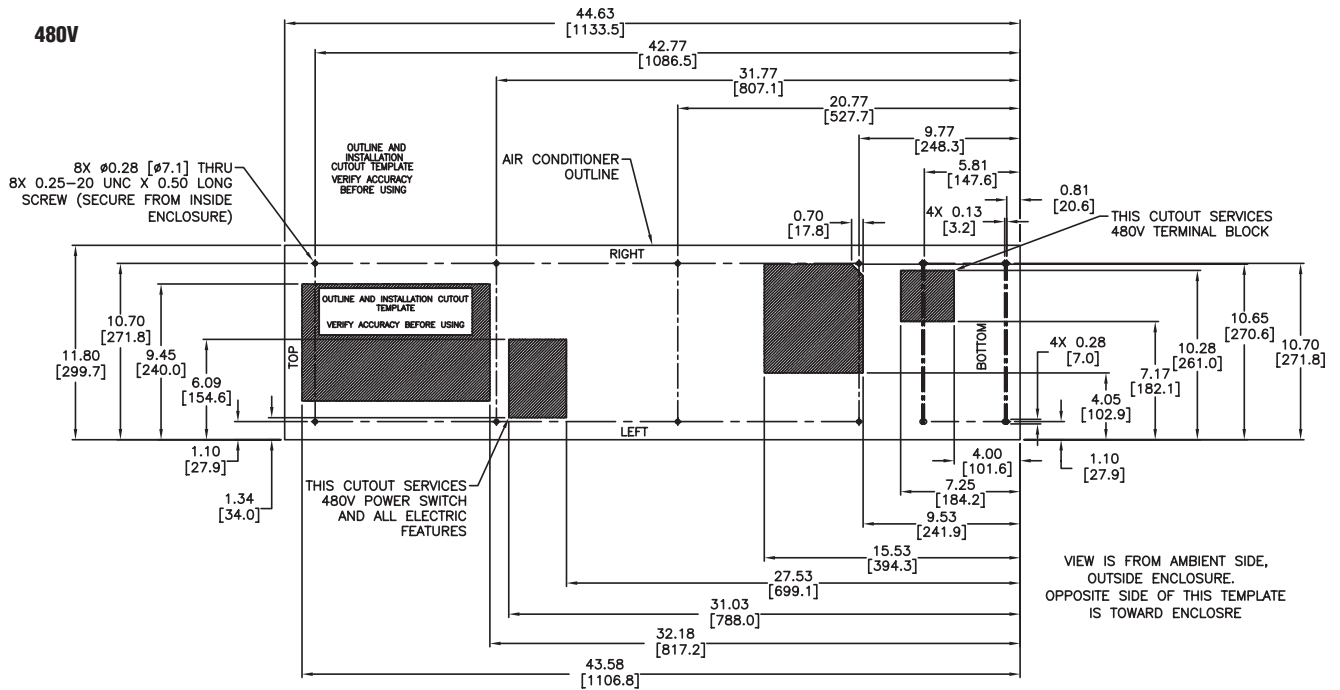

Schematic - 120 Volt

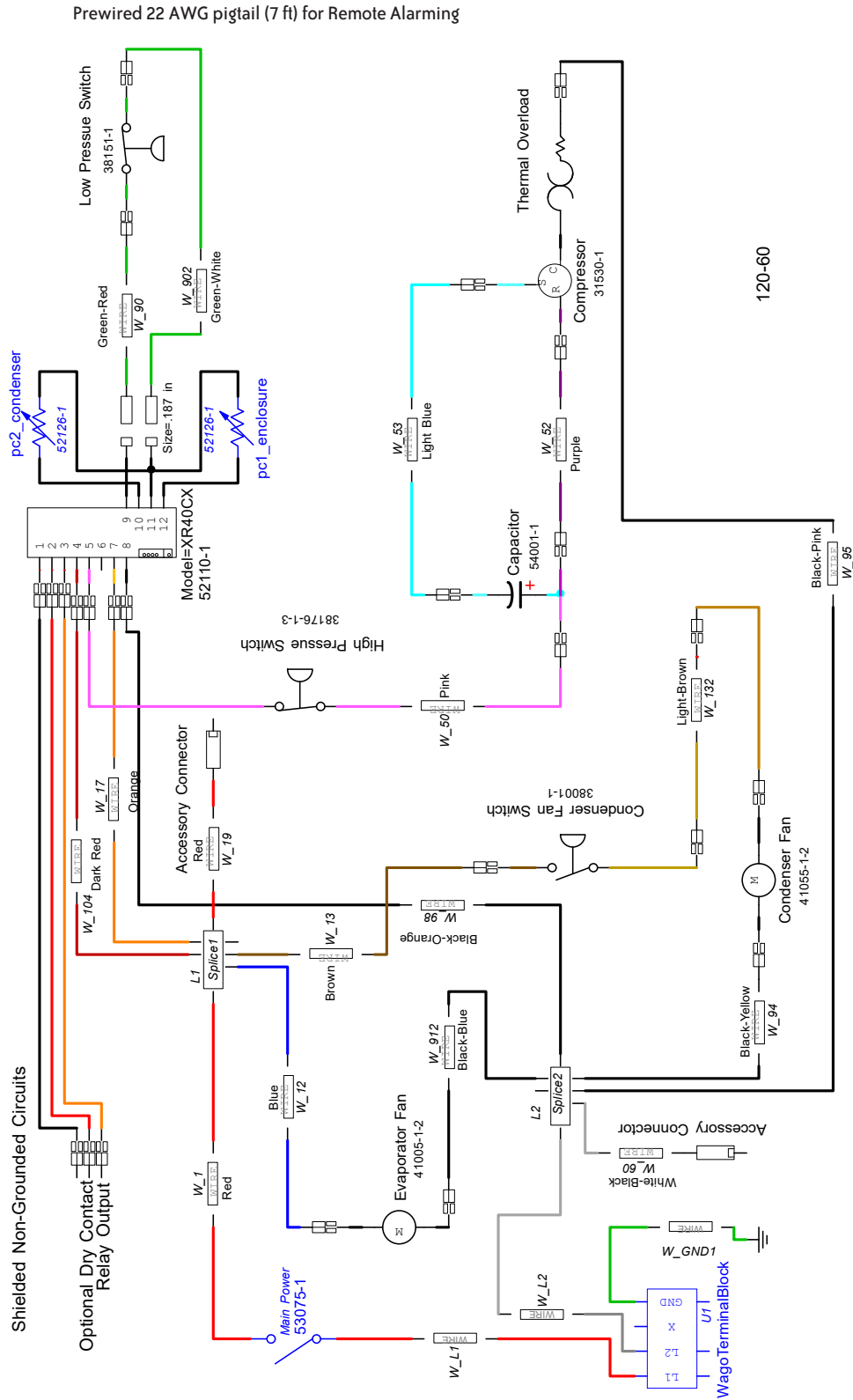

Schematic - 240V

Prewired 22 AWG pigtail (7 ft) for Remote Alarming

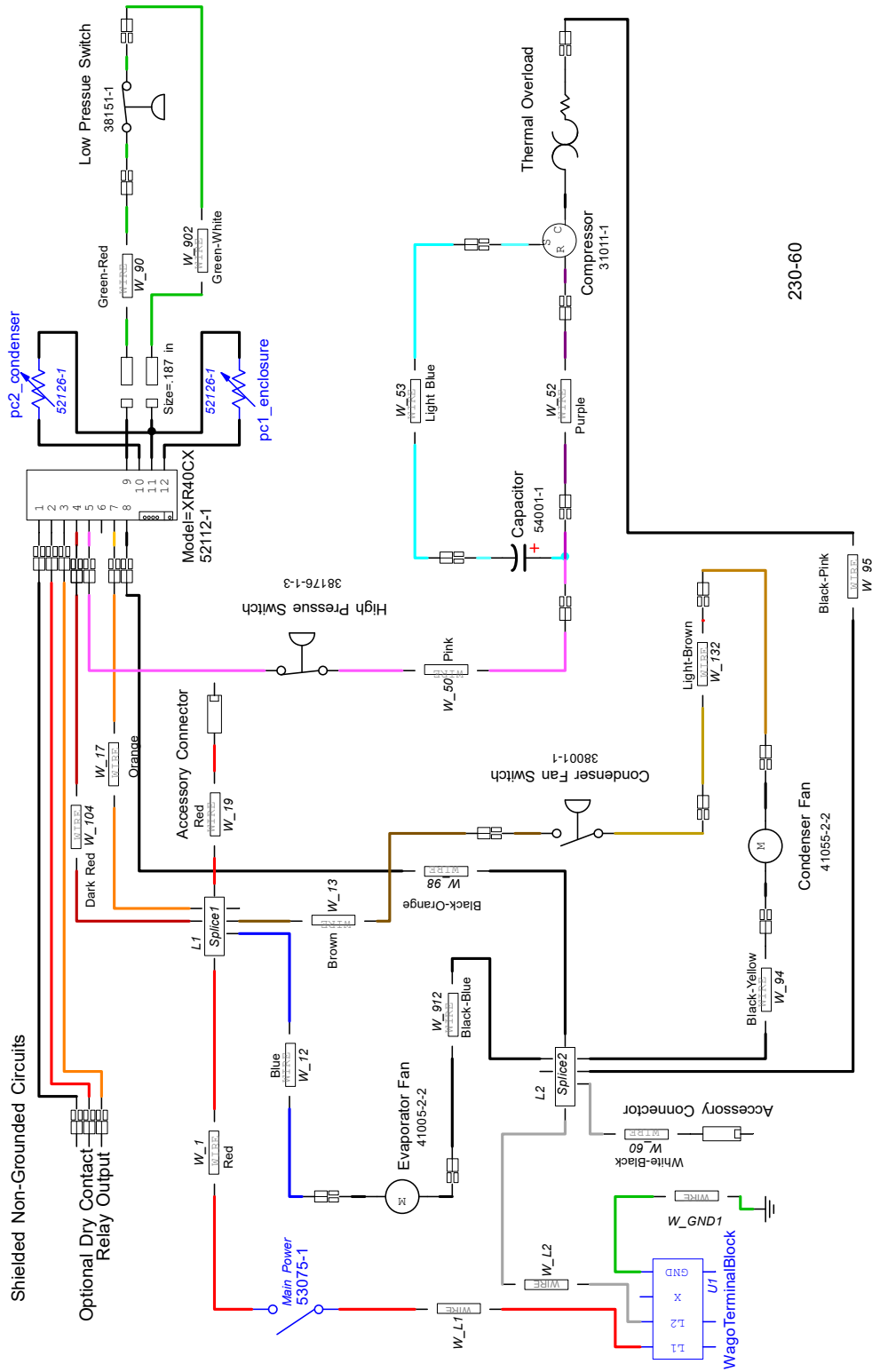

Schematic - 480V

Prewired 22 AWG pigtail (7 ft) for Remote Alarming

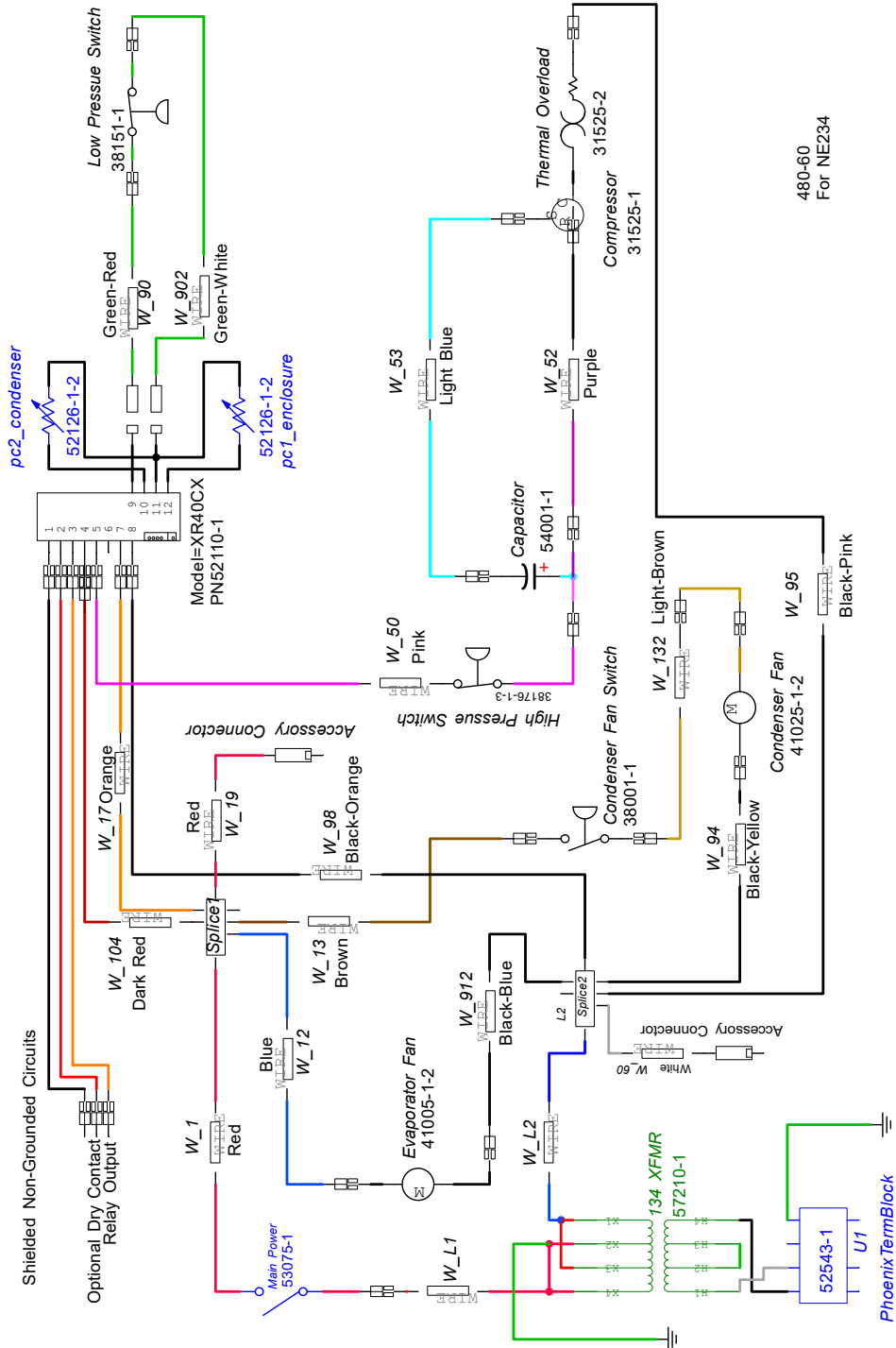

Notes and Model Information

<i>AC Unit Serial Number</i>	
<i>AC Unit Model Number</i>	
<i>Refrigerant Type/ Weight</i>	
<i>Refrigerant Pressure</i>	

Replacement Parts

Wiring Terminal Blocks for Stratus Air Conditioners		
<i>Manufacturer</i>	<i>Manufacturer Part #</i>	<i>Description</i>
1000 - 4000 BTU Models		
Phoenix Contact	1718504	Plug Component
Phoenix Contact	1716522	Feedthrough Header (socket)
5000 - 8000 BTU Models		
Wago	828-334	Feedthrough terminal block; with lever actuation; 4-pole



828-334



1718504



1716522

