

INSTALLATION INSTRUCTIONS

AIR HANDLERS

FEATURING INDUSTRY STANDARD R-410A REFRIGERANT: 

(-)H1T High Efficiency with Aluminum Coil

(-)H2T High Efficiency 2-Stage with Aluminum Coil



RECOGNIZE THIS SYMBOL AS AN INDICATION OF IMPORTANT SAFETY INFORMATION!

▲WARNING

These instructions are intended as an aid to qualified licensed service personnel for proper installation, adjustment and operation of this unit. Read these instructions thoroughly before attempting installation or operation. Failure to follow these instructions may result in improper installation, adjustment, service or maintenance possibly resulting in fire, electrical shock, property damage, personal injury or death.



ISO 9001:2008

Certificate Number: 30164

DO NOT DESTROY THIS MANUAL

PLEASE READ CAREFULLY AND KEEP IN A SAFE PLACE FOR FUTURE REFERENCE BY A SERVICEMAN



TABLE OF CONTENTS

1.0	SAFETY INFORMATION	3
2.0	GENERAL INFORMATION	5
2.1	Important Information About Efficiency and Indoor Air Quality	5
2.2	Receiving	6
2.3	Clearances	6
2.4	Model Number Explanation	7
2.4A	Available Models	8
2.5	Dimensions and Weights	9
3.0	APPLICATIONS	10
3.1	Vertical Upflow	10
3.2	Vertical Downflow	10
3.3	Installation in an Unconditioned Space	12
3.4	Installation in Mobile/Manufactured Homes	13
4.0	ELECTRICAL WIRING	14
4.1	Power Wiring	14
4.2	Control Wiring	14
4.2B	Thermostat Connections	15
4.3	Grounding	19
4.4	Electrical Wiring	19
4.5	Blower Motor Electrical Data	19
4.5A	Blower Motor Electrical Data: (-)H1T	19
4.5B	Blower Motor Electrical Data: (-)H2T	19
4.6	Copper Wire Size	19
4.7	Electric Heat Electrical Data	20
4.7A	Electric Heat Electrical Data: (-)H1T	20
4.7B	Electric Heat Electrical Data: (-)H2T	23
4.7C	Heater Kit Supplemental Information	25
5.0	AIRFLOW PERFORMANCE	26
5.1	Airflow Operating Limits	26
5.2	115/208/240/480V Airflow Performance Data (-)H1T	27
5.3	240V Airflow Performance Data (-)H2T	31
6.0	DUCTWORK	33
7.0	REFRIGERANT CONNECTIONS	33
7.1	TEV Sensing Bulb	33
7.2	Condensate Drain Tubing	34
7.3	Duct Flanges	35
8.0	AIR FILTER	35
9.0	SEQUENCE OF OPERATION	36
9.1	Cooling	36
9.2	Heating (electric heat only)	36
9.3	Heating (heat pump)	36
9.4	Blower Time Delay (heating or cooling)	36
9.5	Defrost (defrost heat control)	36
9.6	Emergency Heat (heating heat pump)	37
9.7	Room Thermostat (anticipator setting)	37
10.0	CALCULATIONS	37
10.1	Calculating Temperature Rise	37
10.2	Calculating BTUH Heating Capacity	37
10.3	Calculating Airflow CFM	37
10.4	Calculating Correction Factor	37
11.0	PRE-START CHECKLIST	38
12.0	MAINTENANCE	38
12.1	Air Filter	38
12.2	Indoor Coil/Drain Pan/Drain Line	39
12.3	Blower Motor & Wheel	39
12.4	Lubrication	39
12.5	Blower Assembly Removal and Replacement	39
12.6	Motor Replacement	40
12.7	Blower Wheel Replacement	40
13.0	REPLACEMENT PARTS	40
14.0	ACCESSORIES - KITS - PARTS	41

⚠ WARNING (SEE SECTION 4.0: ELECTRICAL WIRING)

Disconnect all power to unit before installing or servicing. More than one disconnect switch may be required to de-energize the equipment. Hazardous voltage can cause severe personal injury or death.

⚠ WARNING (SEE SECTION 12.5: BLOWER ASSEMBLY REMOVAL & REPLACEMENT)

If removal of the blower assembly is required, all disconnect switches supplying power to the equipment must be de-energized and locked (if not in sight of unit) so the field power wires can be safely removed from the blower assembly. Failure to do so can cause electrical shock resulting in personal injury or death.

⚠ WARNING

Because of possible damage to equipment or personal injury, installation, service, and maintenance should be performed by a trained, qualified service personnel. Consumer service is recommended only for filter cleaning/replacement. Never operate the unit with the access panels removed.

1.0 SAFETY INFORMATION

⚠ WARNING

Duct leaks can create an unbalanced system and draw pollutants such as dirt, dust, fumes and odors into the home causing property damage. Fumes and odors from toxic, volatile or flammable chemicals, as well as automobile exhaust and carbon monoxide (CO), can be drawn into the living space through leaking ducts and unbalanced duct systems causing personal injury or death (see Figure 1).

- If air-moving equipment or ductwork is located in garages or off-garage storage areas - all joints, seams, and openings in the equipment and duct must be sealed to limit the migration of toxic fumes and odors including carbon monoxide from migrating into the living space.
- If air-moving equipment or ductwork is located in spaces containing fuel burning appliances such as water heaters or boilers - all joints, seams, and openings in the equipment and duct must also be sealed to prevent depressurization of the space and possible migration of combustion byproducts including carbon monoxide into the living space.

⚠ WARNING

These instructions are intended as an aid to qualified, licensed service personnel for proper installation, adjustment and operation of this unit. Read these instructions thoroughly before attempting installation or operation. Failure to follow these instructions may result in improper installation, adjustment, service or maintenance possibly resulting in fire, electrical shock, property damage, personal injury or death.

⚠ WARNING (SEE SECTION 3.2: VERTICAL DOWNFLOW)

The RXHB-17, RXHB-21 or RXHB-24 combustible floor base is required when some units with electric heat are applied downflow on combustible flooring. Failure to use the base can cause a fire resulting in property damage, personal injury or death. See **CLEARANCES** for units requiring a combustible floor base. See the accessory section in this manual for combustible floor base RXHB.

⚠ WARNING (SEE SECTION 4.3: GROUNDING)

The unit must be permanently grounded. Failure to do so can result in electrical shock causing personal injury or death.

⚠ WARNING (SEE SECTION 12.0: MAINTENANCE)

Units with circuit breaker(s) meet requirements as a service disconnect switch, however, if access is required to the line side (covered) of the circuit breaker, this side of the breaker(s) will be energized with the breaker(s) de-energized. Contact with the line side can cause electrical shock resulting in personal injury or death.

⚠ WARNING (SEE SECTION 5.0: DUCTWORK)

Do not, under any circumstances, connect return ductwork to any other heat producing device such as fireplace insert, stove, etc. Unauthorized use of such devices may result in fire, carbon monoxide poisoning, explosion, personal injury or property damage.

WARNING

PROPOSITION 65: This appliance contains fiberglass insulation. Respirable particles of fiberglass are known to the State of California to cause cancer.

All manufacturer products meet current Federal OSHA Guidelines for safety. California Proposition 65 warnings are required for certain products, which are not covered by the OSHA standards.

California's Proposition 65 requires warnings for products sold in California that contain or produce any of over 600 listed chemicals known to the State of California to cause cancer or birth defects such as fiberglass insulation, lead in brass, and combustion products from natural gas.

All "new equipment" shipped for sale in California will have labels stating that the product contains and/or produces Proposition 65 chemicals. Although we have not changed our processes, having the same label on all our products facilitates manufacturing and shipping. We cannot always know "when, or if" products will be sold in the California market.

You may receive inquiries from customers about chemicals found in, or produced by, some of our heating and air-conditioning equipment, or found in natural gas used with some of our products. Listed below are those chemicals and substances commonly associated with similar equipment in our industry and other manufacturers.

- Glass Wool (Fiberglass) Insulation
- Carbon Monoxide (CO).
- Formaldehyde
- Benzene

More details are available at the websites for OSHA (Occupational Safety and Health Administration), at www.osha.gov and the State of California's OEHHA (Office of Environmental Health Hazard Assessment), at www.oehha.org. Consumer education is important since the chemicals and substances on the list are found in our daily lives. Most consumers are aware that products present safety and health risks, when improperly used, handled and maintained.

WARNING (SEE SECTION 12.6: MOTOR REPLACEMENT)

To avoid electrical shock which can result in personal injury or death, use only the screws furnished in the motor shell mounting holds. Screws are #8-18 x .25 in. long blunt nose thread forming. Screws longer than 1/4 in. may contact the motor winding.

WARNING (SEE SECTION 7.0: AIR FILTER)

Do not operate the system without filters. A portion of the dust entrained in the air may temporarily lodge in the duct runs and at the supply registers. Any circulated dust particles could be heated and charred by contact with the air handler elements. This residue could soil ceilings, walls, drapes, carpets and other articles in the house.

Soot damage may occur with filters in place, when certain types of candles, oil lamps or standing pilots are burned.

WARNING

The first 36 inches of supply air plenum and ductwork must be constructed of sheet metal as required by NFPA 90B. The supply air plenum or duct must have a solid sheet metal bottom directly under the unit with no openings, registers or flexible air ducts located in it. If flexible supply air ducts are used they may be located only in the vertical walls of a rectangular plenum, a minimum of 6 inches from the solid bottom. Metal plenum or duct may be connected to the combustible floor base, if not, it must be connected to the unit supply duct flanges such that combustible floor or other combustible material is not exposed to the supply air opening from the downflow unit. Exposing combustible (non-metal) material to the supply opening of a downflow unit can cause a fire resulting in property damage, personal injury or death.

Exceptions to downflow warnings:

- Installations on concrete floor slab with supply air plenum and ductwork completely encased in not less than 2 inches of concrete (See NFPA 90B).

CAUTION (SEE SECTION 3.3: HORIZONTAL)

Horizontal units must be configured for right hand air supply or left hand air supply. Horizontal drain pan must be located under indoor coil. Failure to use the drain pan can result in property damage.

CAUTION (SEE SECTION 2.1: RECEIVING)

In compliance with recognized codes, it is recommended that an auxiliary drain pan be installed under all evaporator coils or units containing evaporator coils that are located in any area of a structure where damage to the building or building contents may occur as a result of an overflow of the coil drain pan or a stoppage in the primary condensate drain piping. See accessories for auxiliary horizontal overflow pan RXBM.

NOTICE

When used in cooling applications, excessive sweating may occur when unit is installed in an unconditioned space. This can result in property damage.

NOTICE

Improper installation, or installation not made in accordance with the Underwriters Laboratory (UL) certification or these instructions, can result in unsatisfactory operation and/or dangerous conditions and are not covered by the unit warranty.

NOTICE

In compliance with recognized codes, it is recommended that an auxiliary drain pan be installed under all evaporator coils or units containing evaporator coils that are located in any area of a structure where damage to the building or building contents may occur as a result of an overflow of the coil drain pan or a stoppage in the primary condensate drain piping. See accessories section of these instructions for auxiliary horizontal overflow pan information (model RXBM).

⚠ NOTICE

Use of this air-handler during construction is not recommended. If operation during construction is absolutely required, the following temporary installation requirements must be followed:

Installation must comply with all Installation Instructions in this manual including the following items:

- Properly sized power supply and circuit breaker/fuse
- Air-handler operating under thermostatic control;
- Return air duct sealed to the air-handler;
- Air filters must be in place;
- Correct air-flow setting for application
- Removing the coil and storing it in a clean safe place is highly recommended until construction is completed and the outdoor unit is installed.
- Clean air-handler, duct work, and components including coil upon completion of the construction process and verify proper air-handler operating conditions according as stated in this instruction manual.
- NOTE: Electric strip heater elements tend to emit a burning odor for a few days if dust has accumulated during construction. Heater elements are easily damaged. Take great care when cleaning them. Low pressure compressed air is recommended for cleaning elements.

2.0 GENERAL INFORMATION

2.1 IMPORTANT INFORMATION ABOUT EFFICIENCY AND INDOOR AIR QUALITY

Central cooling and heating equipment is only as efficient as the duct system that carries the cooled or heated air. To maintain efficiency, comfort and good indoor air quality,

FIGURE 1
MIGRATION OF DANGEROUS SUBSTANCES, FUMES, AND ODORS INTO LIVING SPACES

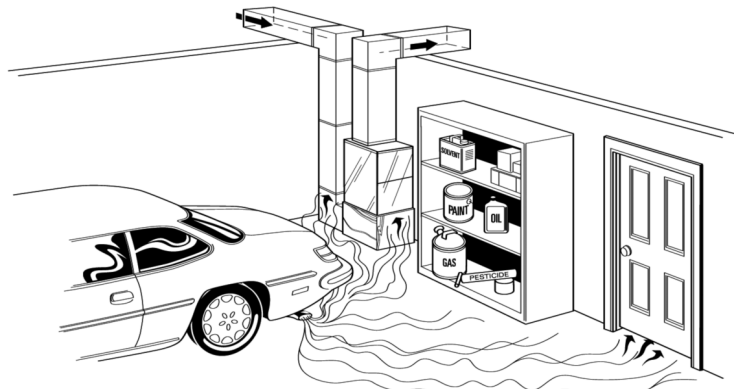

Adapted from *Residential Duct Diagnostics and Repair*, with permission of Air Conditioning Contractors of America (ACCA).

⚠ WARNING



Carbon Monoxide (CO) Poisoning Can Cause Severe Injury or Death.

Carbon Monoxide from the exhaust of motor vehicles and other fuel burning devices can be drawn into the living space by the operation of the central heating and air conditioning system.

Exhaust from motor vehicles, generators, garden tractors, mowers, portable heaters, charcoal and gas grills, gasoline powered tools, and outdoor camping equipment contains carbon monoxide, a poisonous gas that can kill you. You cannot see it, smell it, or taste it.

- Do NOT operate an automobile or any engine in a garage for more than the few seconds it takes to enter or exit the garage.
- Do NOT operate any fuel-burning device in an enclosed or partly enclosed space, or near building windows, doors or air intakes.

The U.S. Consumer Product Safety Commission (CPSC) and Health Canada recommend the installation of UL or CSA certified Carbon Monoxide Alarm(s) in every home.

⚠ WARNING

Duct leaks can create an unbalanced system and draw pollutants such as dirt, dust, fumes and odors into the home causing property damage. Fumes and odors from toxic, volatile or flammable chemicals, as well as automobile exhaust and carbon monoxide (CO), can be drawn into the living space through leaking ducts and unbalanced duct systems causing personal injury or death (see Figure 1).

- If air-moving equipment or ductwork is located in garages or off-garage storage areas - all joints, seams, and openings in the equipment and duct must be sealed to limit the migration of toxic fumes and odors including carbon monoxide from migrating into the living space.
- If air-moving equipment or ductwork is located in spaces containing fuel burning appliances such as water heaters or boilers - all joints, seams, and openings in the equipment and duct must also be sealed to prevent depressurization of the space and possible migration of combustion byproducts including carbon monoxide into the living space.

⚠ NOTICE

Improper installation, or installation not made in accordance with the Underwriters Laboratory (UL) certification or these instructions, can result in unsatisfactory operation and/or dangerous conditions and are not covered by the unit warranty.

it is important to have the proper balance between the air being supplied to each room and the air returning to the cooling and heating equipment.

Proper balance and sealing of the duct system improves the efficiency of the heating and air conditioning system and improves the indoor air quality of the home by reducing the amount of airborne pollutants that enter homes from spaces where the ductwork and/or equipment is located. The manufacturer and the U.S. Environmental Protection Agency's Energy Star Program recommend that central duct systems be checked by a qualified contractor for proper balance and sealing.

NOTICE

In compliance with recognized codes, it is recommended that an auxiliary drain pan be installed under all evaporator coils or units containing evaporator coils that are located in any area of a structure where damage to the building or building contents may occur as a result of an overflow of the coil drain pan or a stoppage in the primary condensate drain piping. See accessories section of these instructions for auxiliary horizontal overflow pan information (model RXBM).

2.2 RECEIVING

Immediately upon receipt, all cartons and contents should be inspected for transit damage. Units with damaged cartons should be opened immediately. If damage is found, it should be noted on the delivery papers, and a damage claim filed with the last carrier.

- After unit has been delivered to job site, remove carton taking care not to damage unit.
- Check the unit rating plate for unit size, electric heat, coil, voltage, phase, etc. to be sure equipment matches what is required for the job specification.
- Read the entire instructions before starting the installation.
- Some building codes require extra cabinet insulation and gasketing when unit is installed in attic applications.
- If installed in an unconditioned space, apply caulking around the power wires, control wires, refrigerant tubing and condensate line where they enter the cabinet. Seal the power wires on the inside where they exit conduit opening. Caulking is required to pre-vent air leakage into and condensate from forming inside the unit, control box, and on electrical controls.
- Install the unit in such a way as to allow necessary access to the coil/filter rack and blower/control compartment.
- Install the unit in a level position to ensure proper condensate drainage. Make sure unit is level in both directions within 1/8".
- Install the unit in accordance with any local code which may apply and the national codes. Latest editions are available from: "National Fire Protection Association, Inc., Batterymarch Park, Quincy, MA 02269." These publications are:
 - ANSI/NFPA No. 70-(Latest Edition) National Electrical Code.
 - NFPA90A Installation of Air Conditioning and Ventilating Systems.
 - NFPA90B Installation of warm air heating and air conditioning systems.
- The equipment has been evaluated in accordance with the Code of Federal Regulations, Chapter XX, Part 3280.

2.3 CLEARANCES

- All units are designed for "0" inches clearance to combustible material on all cabinet surfaces.
- Units with electric heat require a one inch clearance to combustible material for the first three feet of supply plenum and ductwork.
- Some units require a combustible floor base depending on the heating kW. The following table should be used to determine these requirements.

Model Cabinet Size	17	21	24
Maximum Model Designation kW	15	18	20

Additionally, if these units are installed down-flow, a combustible floor base is required. See Accessories for Combustible Floor Base RXHB-XX.

Units with electric heating kW equal to or less than the values listed in the table do not require a combustible floor base.

- Vertical units require clearance on at least one side of the unit for electrical connections. Horizontal units require clearance on either top or bottom for electrical connections. Refrigerant and condensate drain connections are made on the front of the unit.
- All units require 24 inches minimum access to the front of the unit for service.
- These units may be installed in either ventilated or nonventilated spaces.

2.4 MODEL NUMBER EXPLANATION

FIGURE 2
MODEL NUMBER EXPLANATION

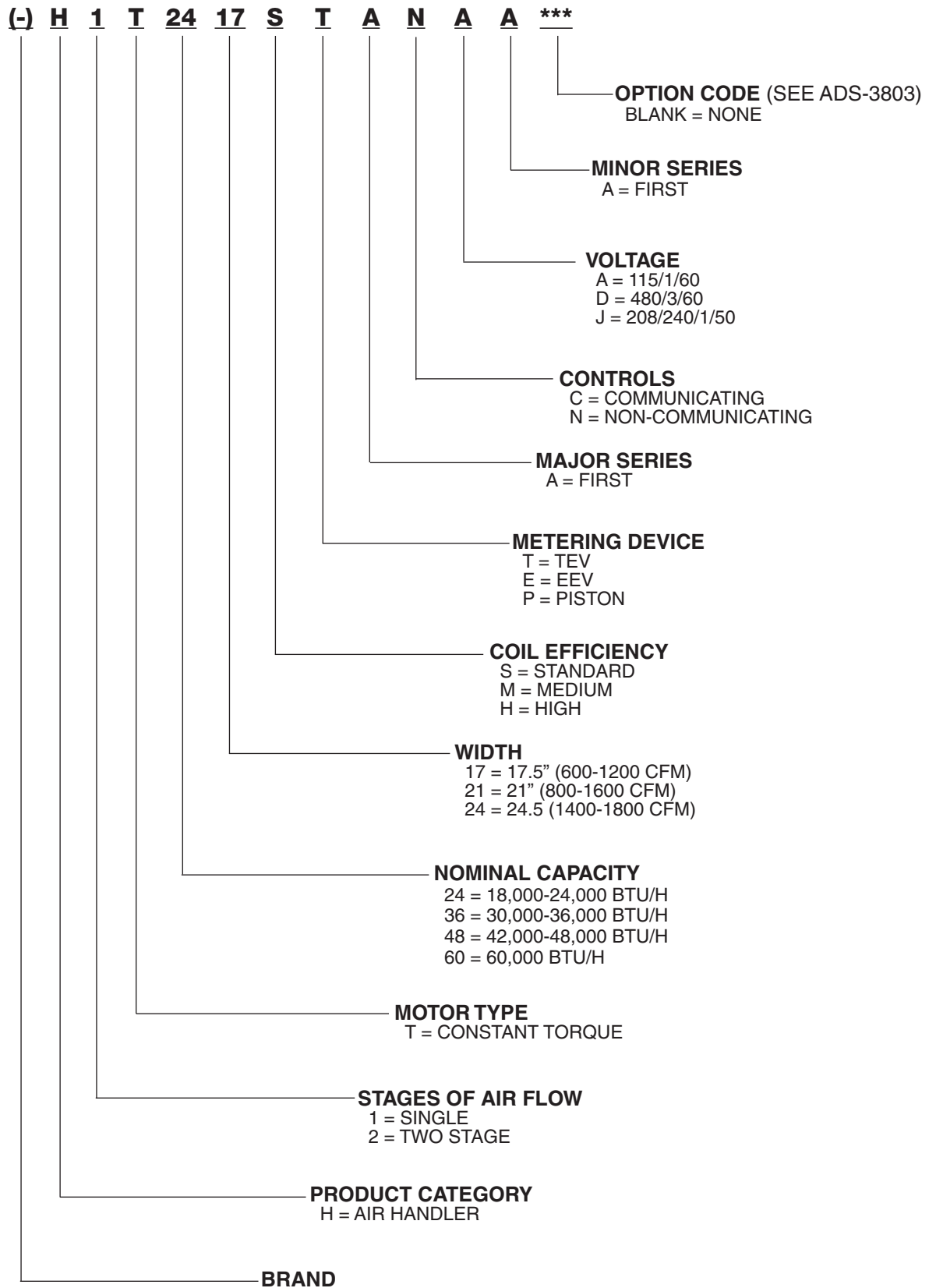

2.4A AVAILABLE MODELS

AVAILABLE MODELS AT A VOLTAGE

(-)H1T2417STANAA
(-)H1T3617STANAA
(-)H1T3621HTANAA
(-)H1T3621MTANAA
(-)H1T4821MTANAA
(-)H1T4821STANAA
(-)H1T4824STANAA
(-)H1T6021STANAA
(-)H1T6024STANAA

AVAILABLE MODELS AT J VOLTAGE

(-)H1T2417STANJA
(-)H1T3617STANJA
(-)H1T3621HTANJA
(-)H1T3621MTANJA
(-)H1T4821MTANJA
(-)H1T4821STANJA
(-)H1T4824STANJA
(-)H1T6021STANJA
(-)H1T6024STANJA
(-)H2T2421MTANJA
(-)H2T3621MTANJA
(-)H2T4824MTANJA
(-)H2T6024STANJA

AVAILABLE MODELS AT D VOLTAGE

(-)H1T6024STANDA

Notes:

- Supply circuit protective devices may be fuses or “HACR” type circuit breakers.
- Largest motor load is included in single circuit and multiple circuit 1.
- If non-standard fuse size is specified, use next size larger fuse size.
- J Voltage (208/240V) single phase air handler is designed to be used with single or three phase 208/240V power. In the case of connecting 3-phase power to the air handler terminal block, bring only two leads to the terminal block. Cap, insulate and fully secure the third lead.
- The air handlers are shipped from the factory with the proper indoor coil installed, and cannot be ordered without a coil.
- The air handlers do not have an internal filter rack. An external filter rack or other means of filtration is required.

2.5 DIMENSIONS & WEIGHTS

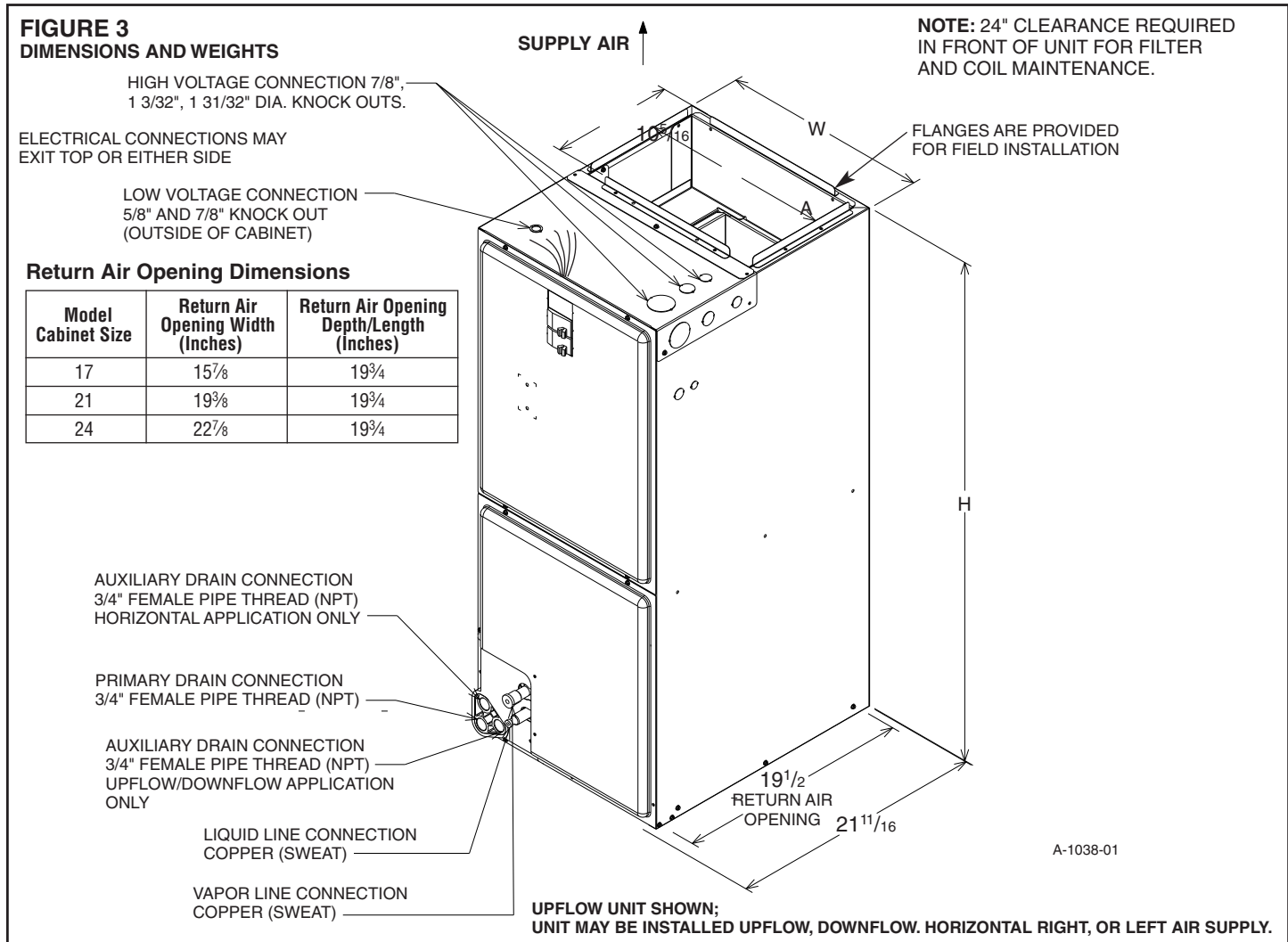

DIMENSIONAL DATA

MODEL SIZE (-)H1T	REFRIGERANT CONNECTIONS		UNIT HEIGHT IN. [mm]	UNIT WIDTH "W" IN. [mm]	SUPPLY DUCT "A" IN. [mm]	AIRFLOW COIL (NOM.) [L/s]		UNIT WEIGHT / SHIPPING WEIGHT (LBS.) [kg]
	SWEAT (IN.) [mm] ID					LO	HI	UNIT WITH COIL (MAX. kW.)
	LIQUID	VAPOR						
2417ST	3/8" [9.53]	3/4" [19.05]	42 1/2" [1080]	17 1/2" [445]	16" [409]	600 [283]	800 [378]	92/106 [42/48]
3617ST	3/8" [9.53]	3/4" [19.05]	42 1/2" [1080]	17 1/2" [445]	16" [409]	1000 [472]	1200 [566]	96/110 [44/50]
3621HT	3/8" [9.53]	7/8" [22.23]	57 [1448]	21" [533]	19 1/2" [495]	1000 [472]	1200 [566]	137/149 [62/68]
3621MT	3/8" [9.53]	7/8" [22.23]	50 1/2" [1282]	21" [533]	19 1/2" [495]	1000 [472]	1200 [566]	126/142 [57/64]
4821MT	3/8" [9.53]	7/8" [22.23]	57 [1448]	21" [533]	19 1/2" [495]	1400 [661]	1600 [755]	139/151 [63/68]
4821ST	3/8" [9.53]	7/8" [22.23]	50 1/2" [1282]	21" [533]	19 1/2" [495]	1400 [661]	1600 [755]	128/144 [56/65]
4824ST	3/8" [9.53]	7/8" [22.23]	50 1/2" [1282]	24 1/2" [622]	23" [585]	1600 [755]	—	142/160 [64/72]
6021HT	3/8" [9.53]	7/8" [22.23]	57 [1448]	21" [533]	19 1/2" [495]	1600 [755]	1725 [814]	139/151 [63/68]
6024ST	3/8" [9.53]	7/8" [22.23]	55 1/2" [1410]	24 1/2" [622]	23" [585]	—	1800 [850]	159/176 [72/80]

MODEL SIZE (-)H2T	UNIT HEIGHT IN. [mm]	UNIT WIDTH "W" IN. [mm]	SUPPLY DUCT "A" IN. [mm]	AIRFLOW (NOM.) [L/s]		UNIT WEIGHT / SHIPPING WEIGHT (LBS.) [kg]
				LO	HI	UNIT WITH COIL (MAX. kW.)
2421MT	42 1/2" [1080]	21" [533.4]	19 1/2" [495.3]	525 [248]	700 [330]	111/126 [50/57]
3621MT	50 1/2" [1282]	21" [533.4]	19 1/2" [495.3]	800 [377]	1050 [495]	129/145 [59/66]
4824MT	55 1/2" [1410]	24 1/2" [622.3]	23" [584]	1050 [495]	1400 [660]	128/146 [58/66]
6024ST	55 1/2" [1410]	24 1/2" [622.3]	23" [584]	1200 [566]	1600 [755]	161/178 [73/81]

3.0 APPLICATIONS

3.1 VERTICAL UPFLOW AND HORIZONTAL LEFT

- Vertical Upflow is the factory configuration for all models (see Figure 3).
- If a side return air opening is required, field fabricate a return air plenum with an opening large enough to supply unit and strong enough to support unit weight.
- If return air is to be ducted, install duct flush with floor. Use fireproof resilient gasket 1/8 to 1/4 in. thick between duct, unit and floor. Set unit on floor over opening.

FIGURE 4
DIMENSIONS FOR FRONT CONNECT COIL

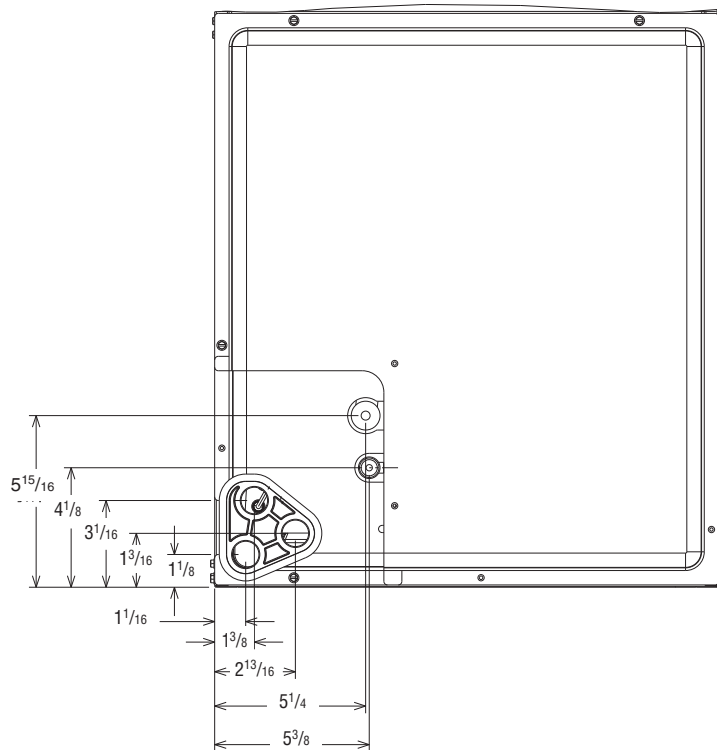

3.2 VERTICAL DOWNFLOW AND HORIZONTAL RIGHT

Conversion to Vertical Downflow: A vertical upflow unit may be converted to vertical downflow. Remove the door and indoor coil and reinstall 180° from original position (see Figure 6). (See kit model number on page 41.)

IMPORTANT: To comply with certification agencies and the National Electric Code for horizontal right application, the circuit breaker(s) on field-installed electric heater kits must be re-installed per procedure below so that the breaker switch “on” position and marking is up and, “off” position and marking is down.

- To turn breaker(s): Rotate one breaker pair (circuit) at a time starting with the one on the right. Loosen both lugs on the load side of the breaker. Wires are bundles with wire ties, one bundle going to the right lug and one bundle going to the left lug.
- Using a screwdriver or pencil, lift white plastic tab with hole away from breaker until breaker releases from mounting opening (see Figure 5).
- With breaker held in hand, rotate breaker so that “on” position is up, “off” position is down with unit in planned vertical mounting position. Insert right wire bundle into top right breaker lug, ensuring all strands of all wires are inserted fully into lug, and no wire insulation is in lug.
- Tighten lug as tight as possible while holding circuit breaker. Check wires and make sure each wire is secure and none are loose. Repeat for left wire bundle in left top circuit breaker lug.
- Replace breaker by inserting breaker mounting tab opposite white pull tab in opening, hook mounting tab over edge in opening.
- With screwdriver or pencil, pull white tab with hole away from breaker while setting that side of breaker into opening. When breaker is in place, release tab, locking circuit breaker into location in opening.

FIGURE 5
ROTATING CIRCUIT BREAKER

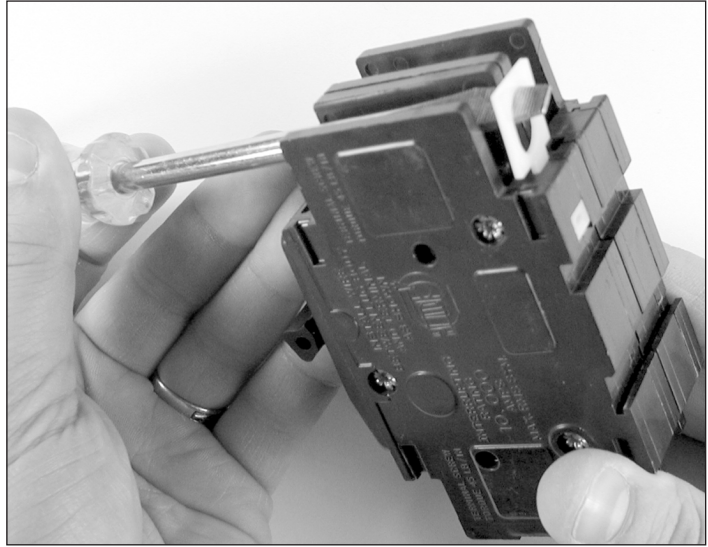

- Repeat above operation for remaining breaker(s) (if more than one is provided).
- Replace single point wiring jumper bar, if it is used, on line side of breaker and tighten securely.
- Double check wires and lugs to make sure all are secure and tight. Check to make sure unit wiring to circuit breaker load lugs match that shown on the unit wiring diagram.
- RXHB combustible floor base is used for all unit sizes. Unit must be centered on combustible base in the width dimension (14 $\frac{3}{8}$ "'). (See Section 14.0 for more information on the combustible floor base.)

DRIP LOOP: When installing the unit in down-flow or horizontal-right positions, make sure that the wires coming from the motor form a proper drip loop. This allows water to cascade off the lowest point of the wiring before it enters the motor head. This may require cutting the wire tie and installing a new wire tie to form this loop.

⚠ WARNING

The RXHB-17, RXHB-21 or RXHB-24 combustible floor base is required when some units with electric heat are applied downflow on combustible flooring. Failure to use the base can cause a fire resulting in property damage, personal injury or death. See CLEARANCES for units requiring a combustible floor base. See the accessory section in this manual for combustible floor base RXHB.

- Rotate unit into the downflow position, with the coil compartment on top and the blower compartment on bottom.
- The set of coil rails must be moved for vertical down-flow and horizontal right application. Remove the coil rail from the factory configuration (6 screws in all). Fastener clearance holes will need to be drilled in the cabinet sides (proper hole locations are marked with "dimples" for this purpose). Note that the shorter (no notch) coil rail must be mounted on the left-hand side to provide clearance for the drain pan condensate connection boss.
- Reinstall the indoor coil 180° from original position. Ensure the retaining channel is fully engaged with the coil rail. (See Figure 6, Detail A.)
- Secondary drain pan kits RXBM- are required when the unit is configured for the horizontal right position over a finished ceiling and/or living space. (See Section 14.0: Accessories - Kits - Parts.)

IMPORTANT: Units cannot be installed horizontally laying on or suspended from the back of the unit.

FIGURE 6
VERTICAL DOWNFLOW & HORIZONTAL RIGHT APPLICATIONS

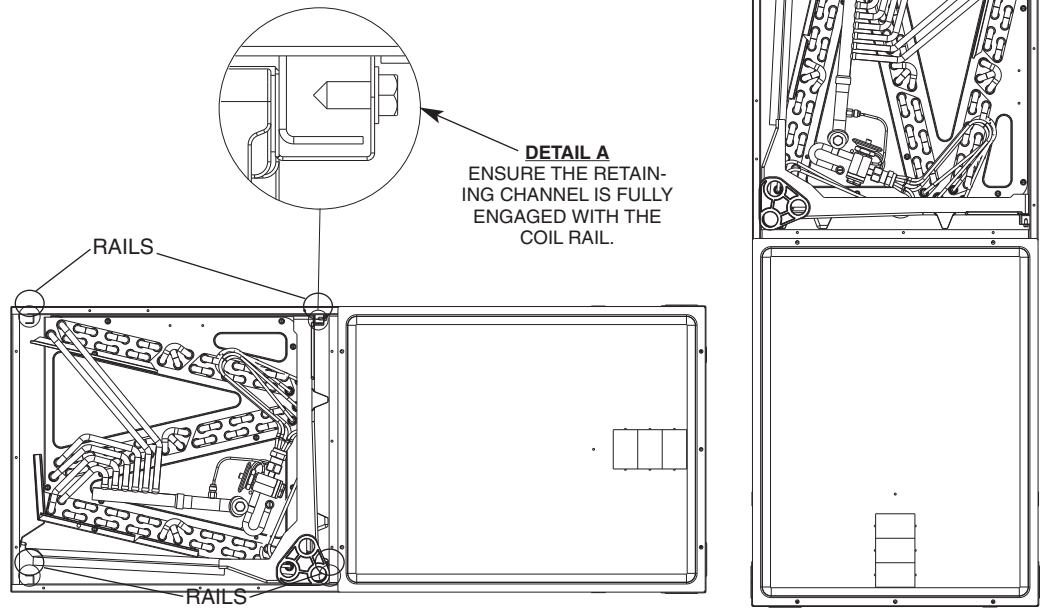

ST-A1213-02

FIGURE 7
INDOOR COIL AND DRAIN PAN SET-UP

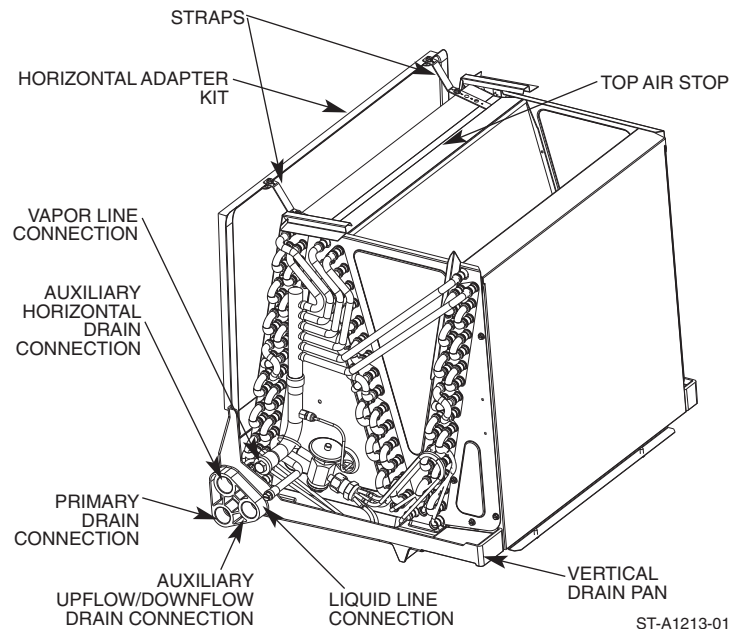

ST-A1213-01

CAUTION

Horizontal units must be configured for right hand air supply or left hand air supply. Horizontal drain pan must be located under indoor coil. Failure to use the drain pan can result in property damage.

Conversion in Horizontal Direction: Horizontal left-hand supply can be changed to horizontal right-hand supply by removing the indoor coil and reinstalling 180° from original. (See Figure 5.)

3.3 INSTALLATION IN AN UNCONDITIONED SPACE

The exterior cabinet of an air handler has a greater risk of sweating when installed in an unconditioned space than when it is installed in the conditioned space. This is primarily

due to the temperature of the conditioned air moving through the air handler and the air circulating around the unit where it is installed. For this reason, we recommend the following for all air handler applications, but special attention should be paid to those installed in unconditioned spaces:

- Duct sizing and airflow are critical and based on the equipment selected
- Supply and return duct attachment: If other than the factory flanges are used, the attachment of ducting must be insulated and tight to prevent sweating.
- No perimeter supply flanges are provided. If a full perimeter supply duct is used, it is the responsibility of the installer to provide duct flanges as needed, to secure and seal the supply duct to prevent air leakage and the sweating that will result.
- All wire penetrations should be sealed. Take care not to damage, remove or compress insulation in those cases.
- In some cases, the entire air handler can be wrapped with insulation. This can be done as long as the unit is completely enclosed in insulation, sealed and service access is provided to prevent accumulation of moisture inside the insulation.
- As required, use a secondary pan that will protect the structure from excessive sweating or a restricted coil drain line.
- If a heater kit is installed, be sure the breaker or disconnect cover is sealed tightly to the door panel.

3.4 INSTALLATION IN MOBILE/MANUFACTURED HOMES

1. Air handler must be secured to the structure using “L” brackets or pipe strap.
2. Allow a minimum of 24 inches (610 mm) front clearance required to access doors.
3. Recommended method for securing air handler:
 - A. If air handler is against the wall, secure top of air handler to wall stud using two 16ga thick angle brackets one on each side. Attach brackets with No. 10 self-tapping $\frac{1}{2}$ ” long screws to air handler and use $\frac{5}{16}$ ” lag screws $1\frac{1}{2}$ ” long to wall stud. Secure bottom of unit with two 16ga “L” brackets with No. 10 self-tapping $\frac{1}{2}$ ” long screws to air handler and use $\frac{5}{16}$ ” lag screws $1\frac{1}{2}$ ” long to floor.
 - B. If air handler is away from wall attach pipe strap to top of air handler using No. 10 $\frac{1}{2}$ ” long self-tapping screws on both sides. Angle strap down and away from back of air handler, remove all slack, and fasten to wall stud of structure using $\frac{5}{16}$ ” lag screws $1\frac{1}{2}$ ” long. Secure bottom of unit with two 16ga “L” brackets with No. 10 self-tapping screws to air handler and use $\frac{5}{16}$ ” lag screws $1\frac{1}{2}$ ” long to floor.

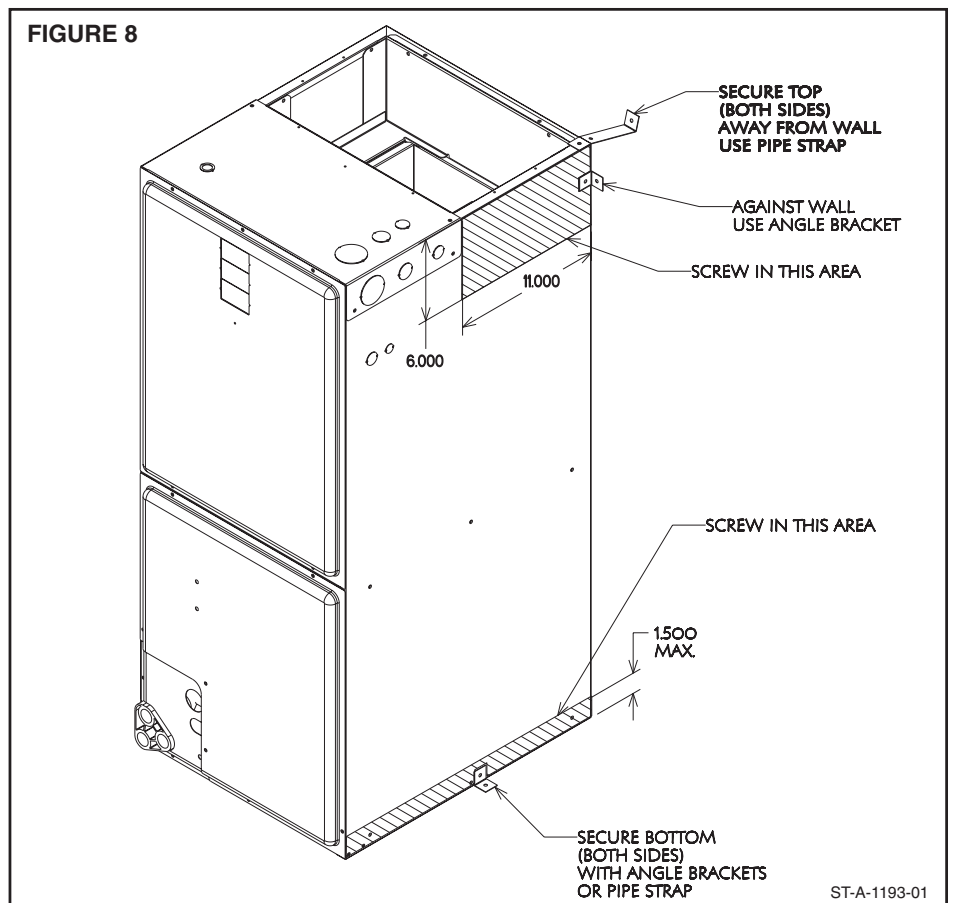

4.0 ELECTRICAL WIRING

Field wiring must comply with the National Electric Code (C.E.C. in Canada) and any applicable local ordinance.

WARNING

Disconnect all power to unit before installing or servicing. More than one disconnect switch may be required to de-energize the equipment. Hazardous voltage can cause severe personal injury or death.

4.1 POWER WIRING

It is important that proper electrical power is available for connection to the unit model being installed. See the unit nameplate, wiring diagram and electrical data in the installation instructions.

- If required, install a branch circuit disconnect of adequate size, located within sight of, and readily accessible to the unit.
- **IMPORTANT:** After the Electric Heater is installed, units may be equipped with one, two, or three 30/60 amp. circuit breakers. These breaker(s) protect the internal wiring in the event of a short circuit and serve as a disconnect. Circuit breakers installed within the unit do not provide over-current protection of the supply wiring and therefore may be sized larger than the branch circuit protection.
- Supply circuit power wiring must be 75°C minimum copper conductors only. See Electrical Data in this section for ampacity, wire size and circuit protector requirement. Supply circuit protective devices may be either fuses or “HACR” type circuit breakers.
- Power wiring may be connected to either the right, left side or top. Three 7/8”, 1^{3/32}”, 1^{31/32}” dia. concentric knockouts are provided for connection of power wiring to unit.
- Power wiring is connected to the power terminal block in unit control compartment.

4.2 CONTROL WIRING

IMPORTANT: Class 2 low voltage control wire should not be run in conduit with power wiring and must be separated from power wiring, unless class 1 wire of proper voltage rating is used.

- Low voltage control wiring should be 18 Awg. color-coded. For lengths longer than 100 ft., 16 Awg. wire should be used.
- Low voltage control connections are made to low voltage pigtails extending from top of air handler (upflow position - see Figure 3). Connections for control wiring are made with wire nuts. Control wiring knockouts (5/8 and 7/8) are also provided on the right and left side of the unit for side connection.
- See wiring diagrams attached to indoor and outdoor sections to be connected, or control wiring diagram booklet supplied with outdoor heat pump section for wiring connection.
- Make sure, after installation, separation of control wiring and power wiring has been maintained.

FIELD WIRE SIZE FOR 24 VOLT THERMOSTAT CIRCUITS

Thermostat Load - Amps	SOLID COPPER WIRE - AWG.					
	3.0	16	14	12	10	10
2.5	16	14	12	12	10	10
2.0	18	16	14	12	12	10
	50	100	150	200	250	300
	Length of Run - Feet (1)					

(1) Wire length equals twice the run distance.

NOTE: Do not use control wiring smaller than No. 18 AWG between thermostat and outdoor unit.

4.2B THERMOSTAT CONNECTIONS

(-)H1T

NOTE: These low voltage application diagrams are generic. Your indoor/outdoor units may not have all the characteristics shown or may not wire exactly as shown. Refer to the diagrams and information sent with your indoor/outdoor sections.

WIRE COLOR CODE:

BK - BLACK	G - GREEN	PR - PURPLE	Y - YELLOW
BR - BROWN	GY - GRAY	R - RED	
GL - BLUE	O - ORANGE	W - WHITE	

FIGURE 9
TYPICAL THERMOSTAT: STD COOLING W / ELECTRIC HEAT

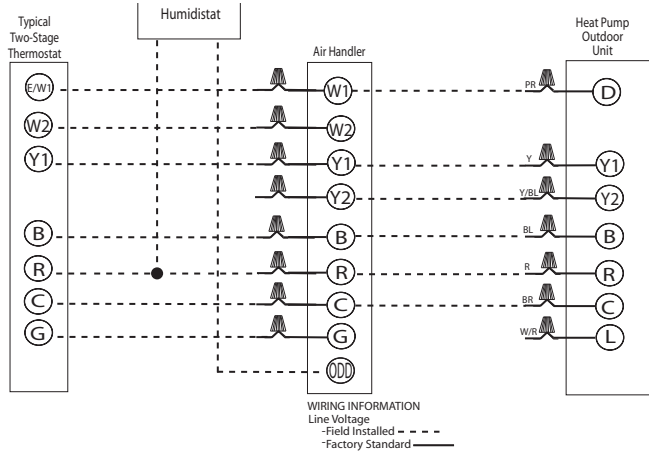

FIGURE 10
TYPICAL THERMOSTAT: STD COOLING W / ELECTRIC HEAT USING A HUMIDISTAT FOR DEHUMIDIFICATION

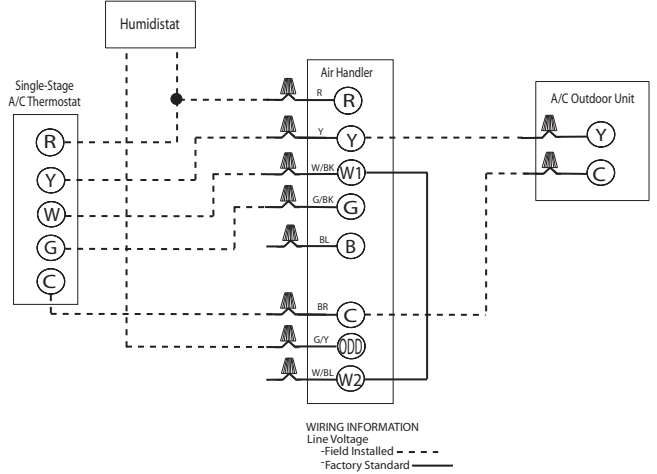

FIGURE 11
TYPICAL THERMOSTAT: STD COOLING W / ELECTRIC HEAT USING A 2-STG DEHUMIDIFYING THERMOSTAT

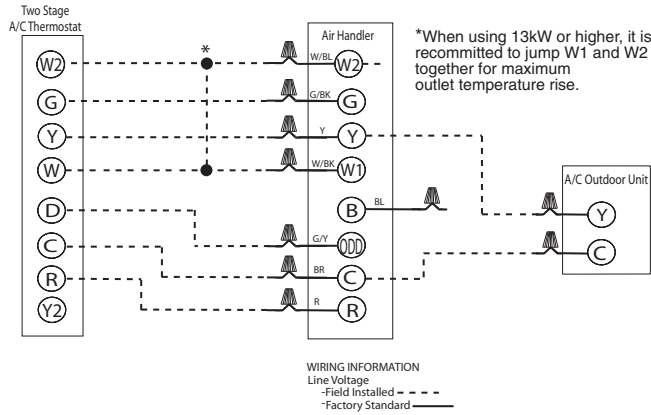

FIGURE 12
TYPICAL THERMOSTAT: HEAT PUMP W / ELECTRIC HEAT

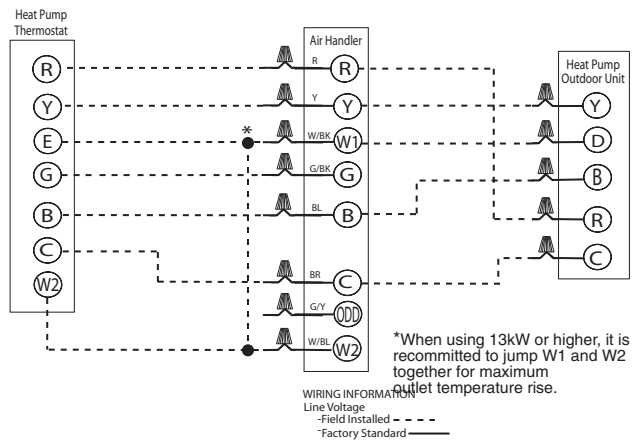

FIGURE 13
TYPICAL THERMOSTAT: HEAT PUMP W / ELECTRIC HEAT USING A HUMIDISTAT FOR DEHUMIDIFICATION

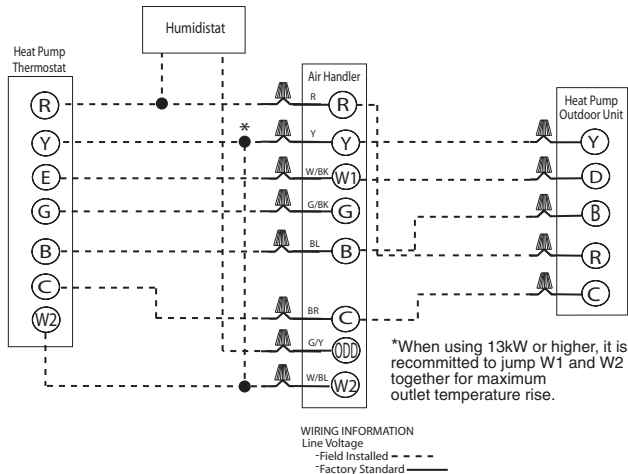
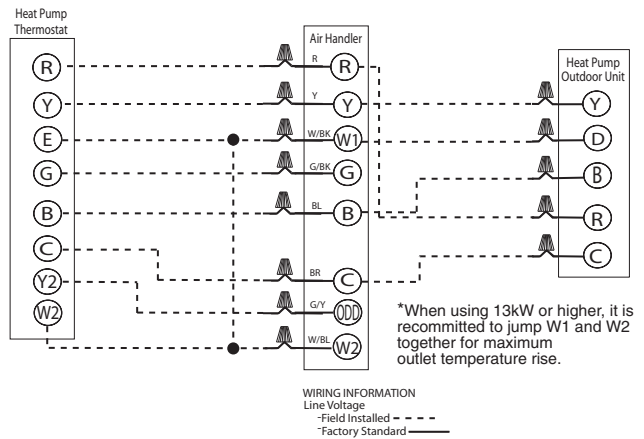

FIGURE 14
TYPICAL THERMOSTAT: HEAT PUMP W / ELECTRIC HEAT USING A 2-STG DEHUMIDIFYING THERMOSTAT



(-)H2T UTILIZING 1ST & 2ND STAGE AIR-FLOW

FIGURE 15
2-STAGE THERMOSTAT, HEAT PUMP, ELECTRIC HEAT

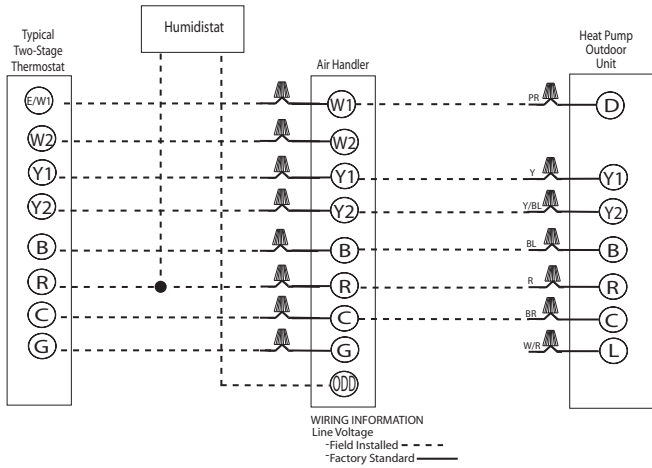

FIGURE 16
2-STAGE THERMOSTAT, HEAT PUMP, ELECTRIC HEAT WITH HUMIDISTAT FOR DEHUMIDIFICATION

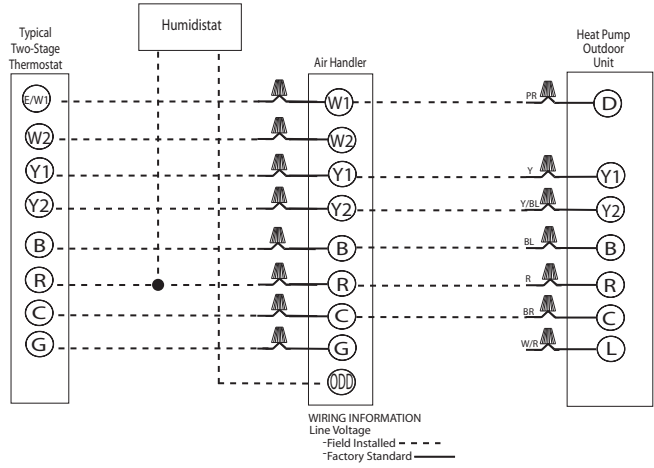

FIGURE 17
2-STAGE THERMOSTAT, HEAT PUMP, ELECTRIC HEAT USING 2-STAGE THERMOSTAT FOR DEHUMIDIFICATION

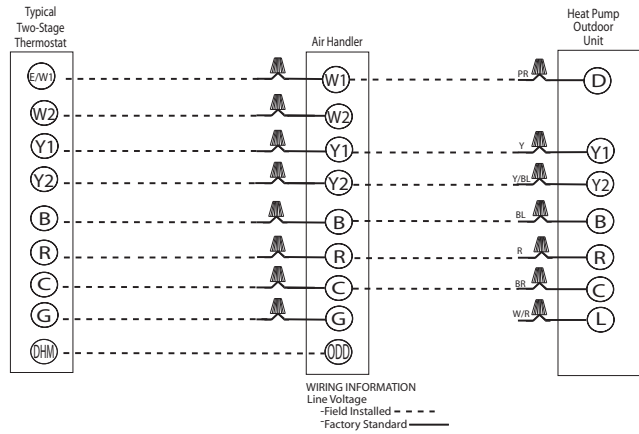
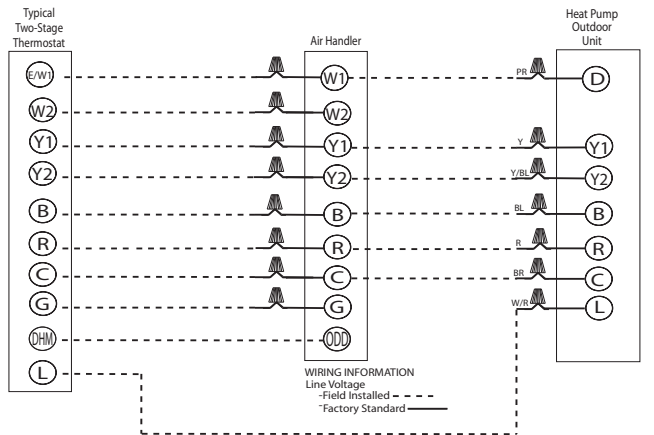

FIGURE 18
2-STAGE THERMOSTAT, HEAT PUMP, ELECTRIC HEAT WITH DEHUMIDIFICATION AND "L" TERMINAL



WIRE COLOR CODE:

BK - BLACK	G - GREEN	PR - PURPLE	Y - YELLOW
BR - BROWN	GY - GRAY	R - RED	
GL - BLUE	O - ORANGE	W - WHITE	

(-)H2T UTILIZING 1ST STAGE AIR-FLOW ONLY FOR SINGLE STAGE SYSTEMS

FIGURE 19
2-STAGE THERMOSTAT, HEAT PUMP, ELECTRIC HEAT

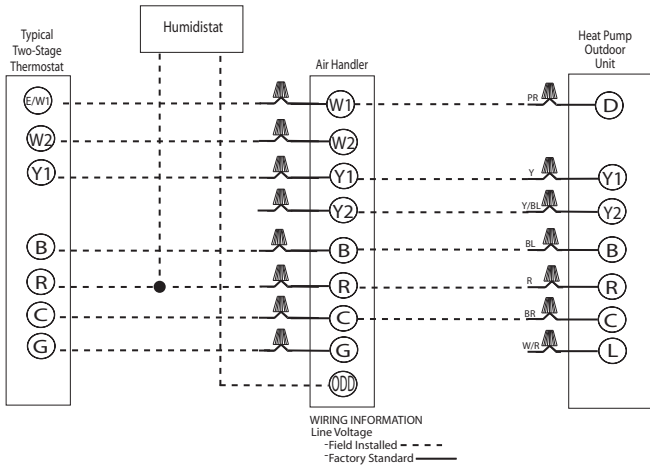

FIGURE 20
2-STAGE THERMOSTAT, HEAT PUMP, ELECTRIC HEAT WITH HUMIDISTAT FOR DEHUMIDIFICATION

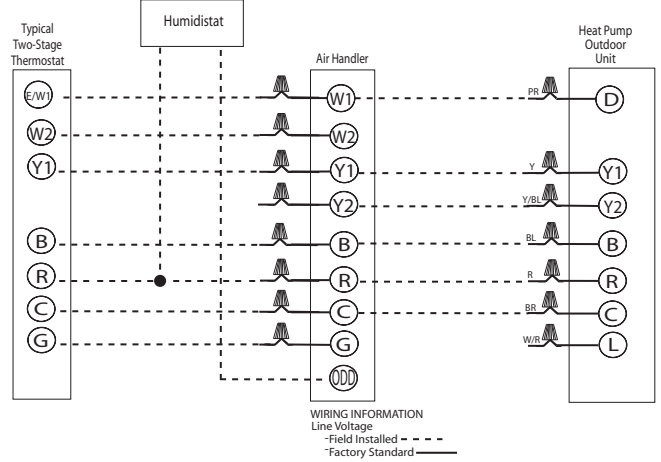

FIGURE 21
2-STAGE THERMOSTAT, HEAT PUMP, ELECTRIC HEAT USING 2-STAGE THERMOSTAT FOR DEHUMIDIFICATION

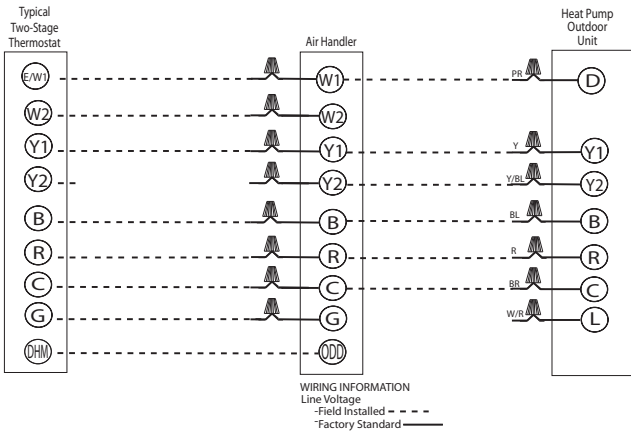
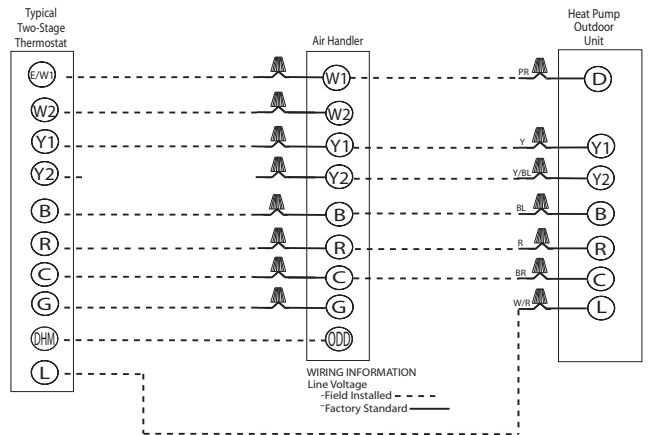

FIGURE 22
2-STAGE THERMOSTAT, HEAT PUMP, ELECTRIC HEAT WITH DEHUMIDIFICATION AND "L" TERMINAL



WIRE COLOR CODE:

BK - BLACK	G - GREEN	PR - PURPLE	Y - YELLOW
BR - BROWN	GY - GRAY	R - RED	
GL - BLUE	O - ORANGE	W - WHITE	

(-)H2T UTILIZING 2ND STAGE AIR-FLOW ONLY FOR SINGLE STAGE SYSTEMS

FIGURE 23
1-STAGE THERMOSTAT, HEAT PUMP, ELECTRIC HEAT

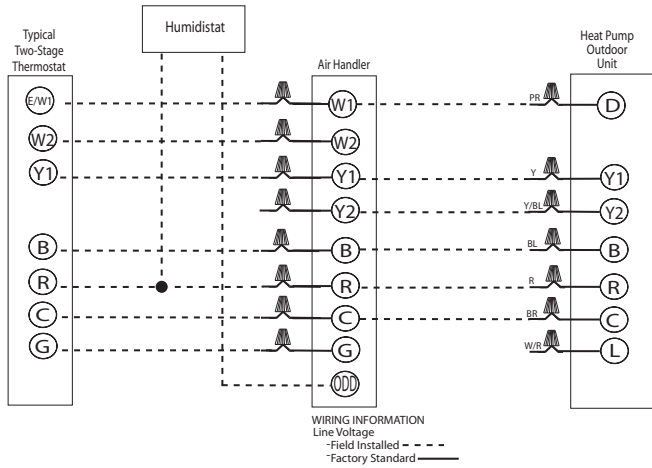

FIGURE 24
1-STAGE THERMOSTAT, HEAT PUMP, ELECTRIC HEAT WITH HUMIDISTAT FOR DEHUMIDIFICATION

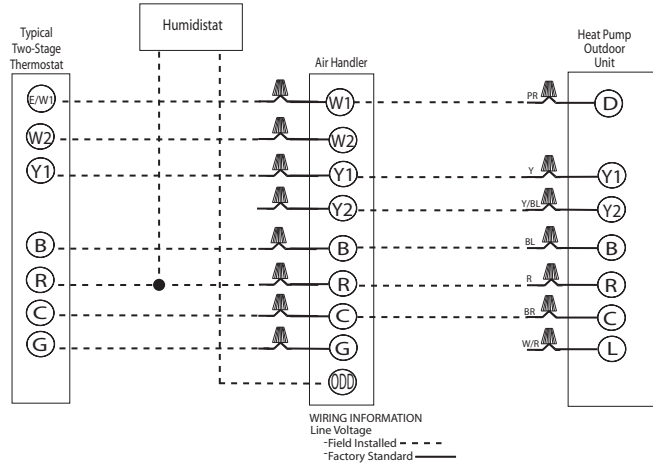

FIGURE 25
2-STAGE THERMOSTAT, HEAT PUMP, ELECTRIC HEAT USING 2-STAGE THERMOSTAT FOR DEHUMIDIFICATION

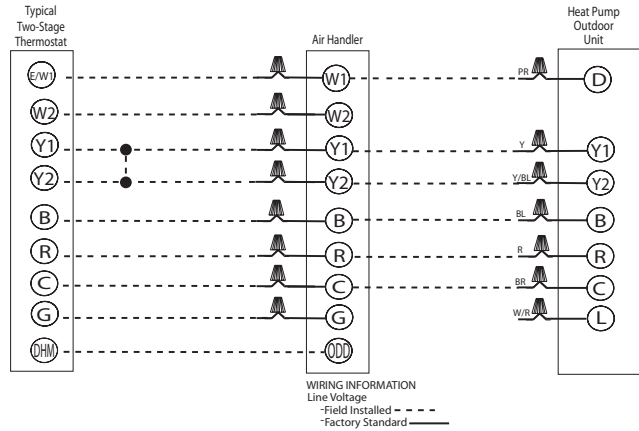
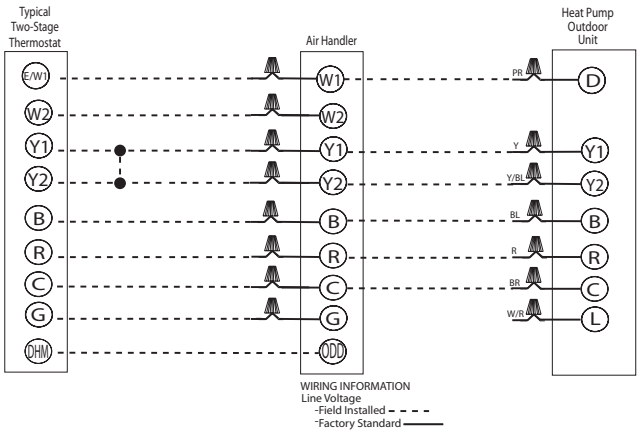

FIGURE 26
2-STAGE THERMOSTAT, HEAT PUMP, ELECTRIC HEAT WITH DEHUMIDIFICATION AND "L" TERMINAL



WIRE COLOR CODE:

BK - BLACK	G - GREEN	PR - PURPLE	Y - YELLOW
BR - BROWN	GY - GRAY	R - RED	
GL - BLUE	O - ORANGE	W - WHITE	

4.3 GROUNDING

WARNING

The unit must be permanently grounded. Failure to do so can result in electrical shock causing personal injury or death.

- Grounding may be accomplished by grounding metal conduit when installed in accordance with electrical codes to the unit cabinet.
- Grounding may also be accomplished by attaching ground wire(s) to ground lug(s) provided in the unit wiring compartment.
- Ground lug(s) are located close to wire entrance on left side of unit (upflow). Lug(s) may be moved to marked locations near wire entrance on right side of unit (upflow), if alternate location is more convenient.
- Use of multiple supply circuits require grounding of each circuit to lug(s) provided in unit.

4.4 ELECTRICAL WIRING

POWER WIRING

- Field wiring must comply with the National Electrical Code (C.E.C. in Canada) and any applicable local ordinance.
- Supply wiring must be 75°C minimum copper conductors only.
- See electrical data for product Ampacity rating and Circuit Protector requirement.

GROUNDING

- This product must be sufficiently grounded in accordance with National Electrical Code (C.E.C. in Canada) and any applicable local ordinance.
- A grounding lug is provided.

4.5 ELECTRICAL DATA – BLOWER MOTOR ONLY – NO ELECTRIC HEAT

4.5A Electrical Data – Blower Motor Only – No Electric Heat: (-)H1T

MODEL (-)H1T	VOLTAGE	PHASE*	HERTZ	HP	RPM	SPEEDS	CIRCUIT AMPS.	MINIMUM CIRCUIT AMPACITY	MAXIMUM CIRCUIT PROTECTOR
2417ST	208/240	1 & 3	60	1/3	300-1100	4	1.6	2	15
3617ST				1/2	300-1100	4	2.7	4	15
3621MT/3621H				1/2	300-1100	4	3.8	5	15
4821ST/4821M/6021S				3/4	300-1100	4	3.8	5	15
6024ST/4824ST				3/4	300-1100	4	4.6	6	15
2417ST	115	1	60	1/3	300-1100	4	4.8	6	15
3617ST				1/2	300-1100	4	6.8	9	15
3621MT/3621H				1/2	300-1100	4	6.8	9	15
4821ST/4821M/6021S				3/4	300-1100	4	8.4	11	15
6024ST				3/4	300-1100	4	8.4	11	15
6024ST	480	3	60	3/4	300-1100	4	3.2	4.0	15

*Blower motors are all single phase motors.

4.5B Electrical Data – Blower Motor Only – No Electric Heat: (-)H2T

MODEL (-)H2T	VOLTAGE	PHASE*	HERTZ	HP	RPM	SPEEDS	CIRCUIT AMPS.	MINIMUM CIRCUIT AMPACITY	MAXIMUM CIRCUIT PROTECTOR
2421MT	208/240	1 & 3	60	1/3	300-1100	4	1.6	2	15
3621MT				3/4	300-1100	4	3.8	5	15
6024ST/4824MT				3/4	300-1100	4	4.6	6	15

*Blower motors are all single phase motors.

4.6 COPPER WIRE SIZE - AWG. (3% VOLTAGE DROP)

SUPPLY	LENGTH	SUPPLY CIRCUIT AMPACITY																	
		200 [61]	12	10	8	8	8	6	6	6	6	4	4	3	3	2	2	1	0
		150 [46]	12	10	10	10	8	8	6	6	6	4	4	3	3	2	1	0	00
		100 [30]	14	12	10	10	8	8	8	6	6	4	4	3	3	2	1	0	00
		50 [15]	14	12	10	10	8	8	8	6	6	4	4	3	3	2	1	0	00
			15	20	25	30	35	40	45	50	60	70	80	90	100	110	125	150	175

NOTE: WIRE BASED ON COPPER CONDUCTORS 75°C MINIMUM RATING. FOR MORE THAN 3 CONDUCTORS IN A RACEWAY OR CABLE, SEE N.E.C. FOR DERATING THE AMPACITY OF EACH CONDUCTOR.

4.7A ELECTRICAL DATA – WITH ELECTRIC HEAT (-)H1T

Installation of the UL Listed original equipment manufacturer provided heater kits listed in the following table is recommended for all auxiliary heating requirements.

AIR HANDLER MODEL (-)H1T	HEATER MODEL NO.	HEATER KW (208/240V) (480V)	PH/HZ	NO. ELEMENTS - KW PER	TYPE SUPPLY CIRCUIT SINGLE CIRCUIT MULTIPLE CIRCUIT	CIRCUIT AMPS.	MOTOR AMPACITY	MINIMUM CIRCUIT AMPACITY	MAXIMUM CIRCUIT PROTECTION
2417ST	RXBH-172403J	2.25/3.0	1/60	1-3.0	SINGLE	10.8/12.5	1.6	16/18	20/20
	RXBH-172403J	2.25/3.0	1/60	1-3.0	SINGLE	10.8/12.5	1.6	16/18	20/20
	RXBH-172405J	3.6/4.8	1/60	1-4.8	SINGLE	17.3/20.0	1.6	24/27	25/30
	RXBH-172407J	5.4/7.2	1/60	2-3.6	SINGLE	26.0/30.0	1.6	35/40	35/40
	RXBH-172410J	7.2/9.6	1/60	2-4.8	SINGLE	34.6/40.0	1.6	46/52	50/60
	RXBH-1724A13J	9.4/12.5	1/60	3-4.17	SINGLE	45.1/52.1	1.6	59/68	60/70
	RXBH-1724A13J	3.1/4.2	1/60	1-4.17	MULTIPLE CKT 1	15.0/17.4	1.6	21/24	25/25
		6.3/8.3	1/60	2-4.17	MULTIPLE CKT 2	30.1/34.7	0	38/44	40/45
	RXBH-1724A07C	5.4/7.2	3/60	3-2.4	SINGLE	15.0/17.3	1.6	21/24	25/25
RXBH-1724A10C	7.2/9.6	3/60	3-3.2	SINGLE	20.0/23.1	1.6	27/31	30/35	
RXBH-1724A13C	9.4/12.5	3/60	3-4.17	SINGLE	26.1/30.1	1.6	35/40	35/40	
3617ST	RXBH-172403J	2.25/3.0	1/60	1-3.0	SINGLE	10.8/12.5	2.8	17/20	20/20
	RXBH-172403J	2.25/3.0	1/60	1-3.0	SINGLE	10.8/12.5	2.8	17/20	20/20
	RXBH-172405J	3.6/4.8	1/60	1-4.8	SINGLE	17.3/20.0	2.8	26/29	30/30
	RXBH-172407J	5.4/7.2	1/60	2-3.6	SINGLE	26.0/30.0	2.8	36/41	40/45
	RXBH-172410J	7.2/9.6	1/60	2-4.8	SINGLE	34.6/40.0	2.8	47/54	50/60
	RXBH-1724A13J	9.4/12.5	1/60	3-4.17	SINGLE	45.1/52.1	2.8	60/69	60/70
	RXBH-1724A13J	3.1/4.2	1/60	1-4.17	MULTIPLE CKT 1	15.0/17.4	2.8	23/26	25/30
		6.3/8.3	1/60	2-4.17	MULTIPLE CKT 2	30.1/34.7	0	38/44	40/45
	RXBH-1724A15J	10.8/14.4	1/60	3-4.8	SINGLE	51.9/60.0	2.8	69/79	70/80
	RXBH-1724A15J	3.6/4.8	1/60	1-4.8	MULTIPLE CKT 1	17.3/20.0	2.8	26/29	30/30
		7.2/9.6	1/60	2-4.8	MULTIPLE CKT 2	34.6/40.0	0	44/50	45/50
	RXBH-1724A18J	12.8/17.0	1/60	3-5.68	SINGLE	61.6/70.8	2.8	81/92	90/100
	RXBH-1724A18J	4.3/5.7	1/60	1-5.68	MULTIPLE CKT 1	20.5/23.6	2.8	29/33	30/35
		8.5/11.3	1/60	2-5.68	MULTIPLE CKT 2	41.1/47.2	0	52/59	60/60
	RXBH-1724A07C	5.4/7.2	3/60	3-2.4	SINGLE	15.0/17.3	2.8	23/26	25/30
	RXBH-1724A10C	7.2/9.6	3/60	3-3.2	SINGLE	20.0/23.1	2.8	29/33	30/35
	RXBH-1724A13C	9.4/12.5	3/60	3-4.17	SINGLE	26.1/30.1	2.8	37/42	40/45
	RXBH-1724A15C	10.8/14.4	3/60	3-4.8	SINGLE	30.0/34.6	2.8	41/47	45/50
RXBH-1724A18C	12.8/17.0	3/60	3-5.68	SINGLE	35.5/41.0	2.8	48/55	50/60	
3621MT	RXBH-172405J	3.6/4.8	1/60	1-4.8	SINGLE	17.3/20.0	4.0	27/30	30/30
	RXBH-172407J	5.4/7.2	1/60	2-3.6	SINGLE	26.0/30.0	4.0	38/43	40/45
	RXBH-172410J	7.2/9.6	1/60	2-4.8	SINGLE	34.6/40.0	4.0	49/55	50/60
	RXBH-1724A15J	10.8/14.4	1/60	3-4.8	SINGLE	51.9/60.0	4.0	70/80	70/80
	RXBH-1724A15J	3.6/4.8	1/60	1-4.8	MULTIPLE CKT1	17.3/20.0	4.0	27/30	30/30
		7.2/9.6	1/60	2-4.8	MULTIPLE CKT 2	34.6/40.0	0.0	44/50	45/50
	RXBH-1724A18J	12.8/17.0	1/60	4-4.26	SINGLE	61.6/70.8	4.0	82/94	90/100
	RXBH-1724A18J	6.4/8.5	1/60	2-4.26	MULTIPLE CKT 1	30.8/35.4	4.0	44/50	45/50
		6.4/8.5	1/60	2-4.26	MULTIPLE CKT 2	30.8/35.4	0.0	39/45	40/45
	RXBH-1724A07C	5.4/7.2	3/60	3-2.4	SINGLE	15.0/17.3	4.0	24/27	25/30
	RXBH-1724A10C	7.2/9.6	3/60	3-3.2	SINGLE	20.0/23.1	4.0	30/34	30/35
	RXBH-1724A15C	10.8/14.4	3/60	3-4.8	SINGLE	30.0/34.6	4.0	43/49	45/50
RXBH-1724A18C	12.8/17.0	3/60	3-2.84	SINGLE	35.6/41.0	4.0	50/57	50/60	
RXBH-1724B05J	3.6/4.8	1/60	1-4.8	SINGLE	17.3/20.0	4.0	27/30	30/30	
RXBH-1724B07J	5.4/7.2	1/60	2-3.6	SINGLE	26.0/30.0	4.0	38/43	40/45	
RXBH-1724B10J	7.2/9.6	1/60	2-4.8	SINGLE	34.6/40.0	4.0	49/55	50/60	

? Heater Kit Connection Type A=Breaker B=Terminal Block C=Pullout Disconnect

4.7A ELECTRICAL DATA – WITH ELECTRIC HEAT: (-)H1T - continued

AIR HANDLER MODEL (-)H1T	HEATER MODEL NO.	HEATER KW (208/240V) (480V)	PH/HZ	NO. ELEMENTS - KW PER	TYPE SUPPLY CIRCUIT SINGLE CIRCUIT MULTIPLE CIRCUIT	CIRCUIT AMPS.	MOTOR AMPACITY	MINIMUM CIRCUIT AMPACITY	MAXIMUM CIRCUIT PROTECTION	
4821ST 6021ST 4821MT	RXBH-1724?05J	3.6/4.8	1/60	1-4.8	SINGLE	17.3/20.0	4.0	27/30	30/30	
	RXBH-1724?07J	5.4/7.2	1/60	2-3.6	SINGLE	26.0/30.0	4.0	38/43	40/45	
	RXBH-1724?10J	7.2/9.6	1/60	2-4.8	SINGLE	34.6/40.0	4.0	49/53	50/60	
	RXBH-1724A15J	10.8/14.4	1/60	3-4.8	SINGLE	51.9/60.0	4.0	70/80	70/80	
	RXBH-1724A15J	3.6/4.8	1/60	1-4.8	MULTIPLE CKT 1	17.3/20.0	4.0	27/30	30/30	
		7.2/9.6	1/60	2-4.8	MULTIPLE CKT 2	34.6/40.0	0.0	44/50	45/50	
	RXBH-1724A18J	12.8/17.0	1/60	4-4.26	SINGLE	61.6/70.8	4.0	82/94	90/100	
	RXBJ-1724A18J	6.4/8.5	1/60	2-4.26	MULTIPLE CKT 1	30.8/35.4	4.0	44/50	45/50	
		6.4/8.5	1/60	2-4.26	MULTIPLE CKT 2	30.8/35.4	0.0	39/45	40/45	
	RXBH-24A20J	14.4/19.2	1/60	4-4.8	SINGLE	69.2/80	4.0	92/105	100/110	
		7.2/9.6	1/60	2-4.8	MULTIPLE CKT 1	34.6/40.0	4.0	49/55	50/60	
	RXBH-24A20J	7.2/9.6	1/60	2-4.8	MULTIPLE CKT 2	34.6/40.0	0.0	44/50	45/50	
	RXBH-24A25J	18.0/24.0	1/60	6-4.0	SINGLE	86.4/99.9	4.0	113/130	125/150	
	RXBH-24A25J (4-ton only)	6.0/8.0	1/60	2-4.0	MULTIPLE CKT 1	28.8/33.3	4.0	41/47	45/50	
		6.0/8.0	1/60	2-4.0	MULTIPLE CKT 2	28.8/33.3	0.0	36/42	40/45	
		6.0/8.0	1/60	2-4.0	MULTIPLE CKT 3	28.8/33.3	0.0	36/42	40/45	
	RXBH-1724A07C	5.4/7.2	3/60	3-2.4	SINGLE	15.0/17.3	4.0	24/27	25/30	
	RXBH-1724A10C	7.2/9.6	3/60	3-3.2	SINGLE	20.0/23.1	4.0	30/34	30/35	
	RXBH-1724A15C	10.8/14.4	3/60	3-4.8	SINGLE	30.0/34.6	4.0	43/49	45/50	
	RXBH-1724A18C	12.8/17.0	3/60	3-2.84	SINGLE	35.6/41.0	4.0	50/57	50/60	
	RXBH-24A20C*	14.4/19.2	3/60	3-3.2	SINGLE	40.0/46.2	4.0	55/63	60/70	
	RXBH-24A20C	7.2/9.6	3/60	3-3.2	MULTIPLE CKT 1	20.0/23.1	4.0	30/34	30/35	
		7.2/9.6	3/60	3-3.2	MULTIPLE CKT 2	20.0/23.1	0.0	25/29	25/30	
	RXBH-24A25C*	18.0/24.0	3/60	6-4.0	SINGLE	50.0/57.8	4.0	68/77	70/80	
	RXBH-24A25C (4-ton only)	9.0/12.0	3/60	3-4.0	MULTIPLE CKT 1	25.0/28.9	4.0	37/42	40/45	
		9.0/12.0	3/60	3-4.0	MULTIPLE CKT 2	25.0/28.9	0.0	32/37	35/40	
	4824ST 6024ST	RXBH-1724?07J	5.4/7.2	1/60	2-3.6	SINGLE	26.0/30.0	4.6	39/44	40/45
		RXBH-1724?10J	7.2/9.6	1/60	2-4.8	SINGLE	34.6/40.0	4.6	49/56	50/60
RXBH-1724A15J		10.8/14.4	1/60	3-4.8	SINGLE	51.9/60.0	4.6	71/81	80/90	
RXBH-1724A15J		3.6/4.8	1/60	1-4.8	MULTIPLE CKT1	17.3/20.0	4.6	28/31	30/35	
		7.2/9.6	1/60	2-4.8	MULTIPLE CKT 2	34.6/40.0	0	44/50	45/50	
RXBH-1724A18J		12.8/17	1/60	4-4.26	SINGLE	61.6/70.8	4.6	83/95	90/100	
RXBH-1724A18J		6.4/8.5	1/60	2-4.26	MULTIPLE CKT 1	30.8/35.4	4.6	45/50	45/50	
		6.4/8.5	1/60	2-4.26	MULTIPLE CKT 2	30.8/35.4	0	39/45	40/45	
RXBH-24A20J		14.4/19.2	1/60	4-4.8	SINGLE	69.2/80	4.6	93/106	100/110	
RXBH-24A20J		7.2/9.6	1/60	2-4.8	MULTIPLE CKT 1	34.6/40.0	4.6	49/56	50/60	
		7.2/9.6	1/60	2-4.8	MULTIPLE CKT 2	34.6/40.0	0	44/50	45/50	
RXBH-24A25J		18.0/24.0	1/60	6-4.0	SINGLE	86.4/99.9	4.6	114/131	125/150	
RXBH-24A25J		6.0/8.0	1/60	2-4.0	MULTIPLE CKT 1	28.8/33.3	4.6	42/48	45/50	
		6.0/8.0	1/60	2-4.0	MULTIPLE CKT 2	28.8/33.3	0	36/42	40/45	
		6.0/8.0	1/60	2-4.0	MULTIPLE CKT 3	28.8/33.3	0	36/42	40/45	
RXBH-24A30J		21.6/28.8	1/60	6-4.8	SINGLE	103.8/120.	4.6	136/156	150/175	
RXBH-24A30J (5-ton only)		7.2/9.6	1/60	2-4.8	MULTIPLE CKT 1	34.6/40.0	4.6	49/56	50/60	
		7.2/9.6	1/60	2-4.8	MULTIPLE CKT 2	34.6/40.0	0	44/50	45/50	
		7.2/9.6	1/60	2-4.8	MULTIPLE CKT 3	34.6/40.0	0	44/50	45/50	
RXBH-1724A07C		5.4/7.2	3/60	3-2.4	SINGLE	15.0/17.3	4.6	25/28	25/30	
RXBH-1724A10C		7.2/9.6	3/60	3-3.2	SINGLE	20.0/23.1	4.6	31/35	35/35	
RXBH-1724A15C		10.8/14.4	3/60	3-4.8	SINGLE	30.0/34.6	4.6	44/49	45/50	
RXBH-1724A18C		12.8/17.0	3/60	3-2.84	SINGLE	35.6/41.0	4.6	51/57	60/60	
RXBH-24A20C*		14.4/19.2	3/60	3-3.2	SINGLE	40.0/46.2	4.6	56/64	60/70	

? Heater Kit Connection Type A=Breaker B=Terminal Block C=Pullout Disconnect

4.7A ELECTRICAL DATA – WITH ELECTRIC HEAT: (-)H1T - continued

AIR HANDLER MODEL (-)H1T	HEATER MODEL NO.	HEATER KW (208/240V) (480V)	PH/HZ	NO. ELEMENTS - KW PER	TYPE SUPPLY CIRCUIT SINGLE CIRCUIT MULTIPLE CIRCUIT	CIRCUIT AMPS.	MOTOR AMPACITY	MINIMUM CIRCUIT AMPACITY	MAXIMUM CIRCUIT PROTECTION
4824ST 6024ST	RXBH-24A20C	7.2/9.6	3/60	3-3.2	MULTIPLE CKT 1	20.0/23.1	4.6	31/35	35/35
		7.2/9.6	3/60	3-3.2	MULTIPLE CKT 2	20.0/23.1	0	25/29	25/30
	RXBH-24A25C*	18.0/24.0	3/60	6-4.0	SINGLE	50.0/57.8	4.6	69/78	70/80
	RXBH-24A25C	9.0/12.0	3/60	3-4.0	MULTIPLE CKT 1	25.0/28.9	4.6	37/42	40/45
		9.0/12.0	3/60	3-4.0	MULTIPLE CKT 2	25.0/28.9	0	32/37	35/40
	RXBH-24A30C*	21.6/28.8	3/60	6-4.8	SINGLE	60.0/69.4	4.6	81/93	90/100
	RXBH-24A30C (5-ton only)	10.8/14.4	3/60	3-4.8	MULTIPLE CKT 1	30.0/34.7	4.6	44/50	45/50
		10.8/14.4	3/60	3-4.8	MULTIPLE CKT 2	30.0/34.7	0	38/44	40/45
6024ST	RXBH-24A07D	7.2	3/60	2-3.6	SINGLE	8.7	3.2	15	15
	RXBH-24A10D	9.6	3/60	3-3.2	SINGLE	11.6	3.2	19	20
	RXBH-24A15D	14.4	3/60	3-4.8	SINGLE	17.3	3.2	26	30
	RXBH-24A18D	17.0	3/60	3-5.68	SINGLE	20.4	3.2	30	30
	RXBH-24A20D	19.2	3/60	6-3.2	SINGLE	23.2	3.2	33	35
	RXBH-24A25D	24.0	3/60	6-4.0	SINGLE	28.8	3.2	40	40
	RXBH-24A30D	28.8	3/60	6-4.8	SINGLE	34.6	3.2	48	50

- ? Heater Kit Connection Type A=Breaker B=Terminal Block C=Disconnect Pullout

*Values only. No single point kit available.

NOTES:

- Electric heater BTUH - (heater watts + motor watts) x 3.414 (see airflow table for motor watts.)
- Supply circuit protective devices may be fuses or "HACR" type circuit breakers.
- If non-standard fuse size is specified, use next size larger standard fuse size.
- Largest motor load is included in single circuit or circuit 1 of multiple circuits.
- Heater loads are balanced on 3 phase models with 3 or 6 heaters only.
- No electrical heating elements are permitted to be used with A Voltage (115V) air handler.
- J Voltage (208/240V) single phase air handler is designed to be used with single or three phase 208/240V electric heaters. In the case of connecting 3 phase power to air handler terminal block without the heater, bring only two leads to terminal block, cap, insulate and fully secure the third lead.
- Do not use 480V electrical heaters on 208/240V air handler.
- Do not use 208/240V electrical heaters on 480V air handler.
- If the kit is listed under both single and multiple circuits, the kit is shipped from factory as multiple circuits. For single phase application, Jumper bar kit RXBJ-A21 and RXBJ-A31 can be used to convert multiple circuits to a single supply circuit. Refer to Accessory Section for details.

4.7B ELECTRICAL DATA – WITH ELECTRIC HEAT: (-)H2T

Installation of the UL Listed original equipment manufacturer provided heater kits listed in the following table is recommended for all auxiliary heating requirements.

AIR HANDLER MODEL (-)H2T	HEATER MODEL NO.	HEATER KW (208/240V) (480V)	PH/HZ	NO. ELEMENTS - KW PER	TYPE SUPPLY CIRCUIT SINGLE CIRCUIT MULTIPLE CIRCUIT	CIRCUIT AMPS.	MOTOR AMPACITY	MINIMUM CIRCUIT AMPACITY	MAXIMUM CIRCUIT PROTECTION
2421MT	RXBH-1724?05J	3.6/4.8	1/60	1-4.8	SINGLE	17.3/20.0	1.6	24/27	25/30
	RXBH-1724?07J	5.4/7.2	1/60	2-3.6	SINGLE	26.0/30.0	1.6	35/40	35/40
	RXBH-1724?10J	7.2/9.6	1/60	2-4.8	SINGLE	34.6/40.0	1.6	46/52	50/60
	RXBH-1724A13J	9.4/12.5	1/60	3-4.17	SINGLE	45.1/52.1	1.6	59/68	60/70
	RXBH-1724A13J	3.1/4.2	1/60	1-4.17	MULTIPLE CKT 1	15.0/17.4	1.6	21/24	25/25
		6.3/8.3	1/60	2-4.17	MULTIPLE CKT 2	30.1/34.7	0	38/44	40/45
	RXBH-1724A07C	5.4/7.2	3/60	3-2.4	SINGLE	15.0/17.3	1.6	21/24	25/25
	RXBH-1724A10C	7.2/9.6	3/60	3-3.2	SINGLE	20.0/23.1	1.6	27/31	30/35
RXBH-1724A13C	9.4/12.5	3/60	3-4.17	SINGLE	26.1/30.1	1.6	35/40	35/40	
3621MT	RXBH-1724?05J	3.6/4.8	1/60	1-4.8	SINGLE	17.3/20.0	3.8	27/30	30/30
	RXBH-1724?07J	5.4/7.2	1/60	2-3.6	SINGLE	26.0/30.0	3.8	38/43	40/45
	RXBH-1724?10J	7.2/9.6	1/60	2-4.8	SINGLE	34.6/40.0	3.8	48/55	50/60
	RXBH-1724A15J	10.8/14.4	1/60	3-4.8	SINGLE	51.9/60.0	3.8	70/80	70/80
	RXBH-1724A15J	3.6/4.8	1/60	1-4.8	MULTIPLE CKT1	17.3/20.0	3.8	27/30	30/30
		7.2/9.6	1/60	2-4.8	MULTIPLE CKT 2	34.6/40.0	0.0	44/50	45/50
	RXBH-1724A18J	12.8/17.0	1/60	4-4.26	SINGLE	61.6/70.8	3.8	82/94	90/100
	RXBH-1724A18J	6.4/8.5	1/60	2-4.26	MULTIPLE CKT 1	30.8/35.4	3.8	44/49	45/50
		6.4/8.5	1/60	2-4.26	MULTIPLE CKT 2	30.8/35.4	0.0	39/45	40/45
	RXBH-1724A07C	5.4/7.2	3/60	3-2.4	SINGLE	15.0/17.3	3.8	24/27	25/30
	RXBH-1724A10C	7.2/9.6	3/60	3-3.2	SINGLE	20.0/23.1	3.8	30/34	30/35
	RXBH-1724A15C	10.8/14.4	3/60	3-4.8	SINGLE	30.0/34.6	3.8	43/48	45/50
	RXBH-1724A18C	12.8/17.0	3/60	3-2.84	SINGLE	35.6/41.0	3.8	50/56	50/60
	RXBH-1724B05J	3.6/4.8	1/60	1-4.8	SINGLE	17.3/20.0	3.8	27/30	30/30
	RXBH-1724B07J	5.4/7.2	1/60	2-3.6	SINGLE	26.0/30.0	3.8	38/43	40/45
RXBH-1724B10J	7.2/9.6	1/60	2-4.8	SINGLE	34.6/40.0	3.8	48/55	60/60	

- ? Heater Kit Connection Type A=Breaker B=Terminal Block C=Pullout Disconnect

① D Voltage = 480 Volts.

*Values only. No single point kit available.

NOTES:

- Electric heater BTUH - (heater watts + motor watts) x 3.414 (see airflow table for motor watts.)
- Supply circuit protective devices may be fuses or "HACR" type circuit breakers.
- If non-standard fuse size is specified, use next size larger standard fuse size.
- Largest motor load is included in single circuit or circuit 1 of multiple circuits.
- Heater loads are balanced on 3 phase models with 3 or 6 heaters only.
- No electrical heating elements are permitted to be used with A Voltage (115V) air handler.
- J Voltage (208/240V) single phase air handler is designed to be used with single or three phase 208/240V electric heaters. In the case of connecting 3 phase power to air handler terminal block without the heater, bring only two leads to terminal block, cap, insulate and fully secure the third lead.
- Do not use 480V electrical heaters on 208/240V air handler.
- If the kit is listed under both single and multiple circuits, the kit is shipped from factory as multiple circuits. For single phase application, Jumper bar kit RXBJ-A21 and RXBJ-A31 can be used to convert multiple circuits to a single supply circuit. Refer to Accessory Section for details.

4.7B Electrical Data – With Electric Heat: (-)H2T - continued

AIR HANDLER MODEL (-)H2T	HEATER MODEL NO.	HEATER KW (208/240V) (480V)	PH/HZ	NO. ELEMENTS - KW PER	TYPE SUPPLY CIRCUIT SINGLE CIRCUIT MULTIPLE CIRCUIT	CIRCUIT AMPS.	MOTOR AMPACITY	MINIMUM CIRCUIT AMPACITY	MAXIMUM CIRCUIT PROTECTION
4824MT 6024ST	RXBH-1724?07J	5.4/7.2	1/60	2-3.6	SINGLE	26.0/30.0	4.6	39/44	40/45
	RXBH-1724?10J	7.2/9.6	1/60	2-4.8	SINGLE	34.6/40.0	4.6	49/56	50/60
	RXBH-1724A15J	10.8/14.4	1/60	3-4.8	SINGLE	51.9/60.0	4.6	71/81	80/90
	RXBH-1724A15J	3.6/4.8	1/60	1-4.8	MULTIPLE CKT 1	17.3/20.0	4.6	28/31	30/35
		7.2/9.6	1/60	2-4.8	MULTIPLE CKT 2	34.6/40.0	0	44/50	45/50
	RXBH-1724A18J	12.8/17	1/60	4-4.26	SINGLE	61.6/70.8	4.6	83/95	90/100
	RXBH-1724A18J	6.4/8.5	1/60	2-4.26	MULTIPLE CKT 1	30.8/35.4	4.6	45/50	45/50
		6.4/8.5	1/60	2-4.26	MULTIPLE CKT 2	30.8/35.4	0	39/45	40/45
	RXBH-24A20J	14.4/19.2	1/60	4-4.8	SINGLE	69.2/80	4.6	93/106	100/110
	RXBH-24A20J	7.2/9.6	1/60	2-4.8	MULTIPLE CKT 1	34.6/40.0	4.6	49/56	50/60
		7.2/9.6	1/60	2-4.8	MULTIPLE CKT 2	34.6/40.0	0	44/50	45/50
	RXBH-24A25J	18.0/24.0	1/60	6-4.0	SINGLE	86.4/99.9	4.6	114/131	125/150
	RXBH-24A25J	6.0/8.0	1/60	2-4.0	MULTIPLE CKT 1	28.8/33.3	4.6	42/48	45/50
		6.0/8.0	1/60	2-4.0	MULTIPLE CKT 2	28.8/33.3	0	36/42	40/45
		6.0/8.0	1/60	2-4.0	MULTIPLE CKT 3	28.8/33.3	0	36/42	40/45
	RXBH-24A30J	21.6/28.8	1/60	6-4.8	SINGLE	103.8/120.	4.6	136/156	150/175
	RXBH-24A30J (5-ton only)	7.2/9.6	1/60	2-4.8	MULTIPLE CKT 1	34.6/40.0	4.6	49/56	50/60
		7.2/9.6	1/60	2-4.8	MULTIPLE CKT 2	34.6/40.0	0	44/50	45/50
		7.2/9.6	1/60	2-4.8	MULTIPLE CKT 3	34.6/40.0	0	44/50	45/50
	RXBH-1724A07C	5.4/7.2	3/60	3-2.4	SINGLE	15.0/17.3	4.6	25/28	25/30
	RXBH-1724A10C	7.2/9.6	3/60	3-3.2	SINGLE	20.0/23.1	4.6	31/35	35/35
	RXBH-1724A15C	10.8/14.4	3/60	3-4.8	SINGLE	30.0/34.6	4.6	44/49	45/50
	RXBH-1724A18C	12.8/17.0	3/60	3-2.84	SINGLE	35.6/41.0	4.6	51/57	60/60
	RXBH-24A20C*	14.4/19.2	3/60	3-3.2	SINGLE	40.0/46.2	4.6	56/64	60/70
	RXBH-24A20C	7.2/9.6	3/60	3-3.2	MULTIPLE CKT 1	20.0/23.1	4.6	31/35	35/35
		7.2/9.6	3/60	3-3.2	MULTIPLE CKT 2	20.0/23.1	0	25/29	25/30
	RXBH-24A25C*	18.0/24.0	3/60	6-4.0	SINGLE	50.0/57.8	4.6	69/78	70/80
	RXBH-24A25C	9.0/12.0	3/60	3-4.0	MULTIPLE CKT 1	25.0/28.9	4.6	37/42	40/45
		9.0/12.0	3/60	3-4.0	MULTIPLE CKT 2	25.0/28.9	0	32/37	35/40
	RXBH-24A30C*	21.6/28.8	3/60	6-4.8	SINGLE	60.0/69.4	4.6	81/93	90/100
	RXBH-24A30C (5-ton only)	10.8/14.4	3/60	3-4.8	MULTIPLE CKT 1	30.0/34.7	4.6	44/50	45/50
		10.8/14.4	3/60	3-4.8	MULTIPLE CKT 2	30.0/34.7	0	38/44	40/45

? Heater Kit Connection Type A=Breaker B=Terminal Block C=Pullout Disconnect

4.7C HEATER KIT SUPPLEMENTAL INFORMATION

MFD: MO/YEAR 01/2006 AIR CONDITIONING DIVISION MADE IN THE U.S.A. / FRQ: MO/JANNE FAIT DANS L'USA

MODEL/MODELE # SERIAL/EN SERIE # M0106 38751

VOLTS 208/240 PH/Hz 1/60 MOTOR HP/F.L.A. 1/2 4.1 MOTEUR PSC/F.L.A.

ATTENTION: MARK HEATER INSTALLED / L'APPAREIL DE CHAUFFAGE DE MARQUE A INSTALLER

HEATER MODEL/MODELE D'APPAREIL DE CHAUFFAGE	TYPE SUPPLY CIRCUIT/TYPAGE LE CIRCUIT DE PROVISION	VOLTAGE/TENSION	PHASE	KW	HEATER AMPS/AMPLIS D'APPAREIL DE CHAUFFAGE	MOTOR AMPS/LES AMPLIS MOTEURS	PROTECTION LA PROTECTION MAXIMUM DE OVERCURRENT	MINIMUM BRANCH CIRCUIT AMPCITY/AMPACITY MINIMUM DE CIRCUIT DE BRANCHE
NO HEAT				0.0		4.1	15	5.2
RYBH-24A05J	SINGLE	208/240	1/60	3.6/4.8	17.3/20.0	6.0	30/35	30/33
RYBH-24A07J	SINGLE	208/240	1/60	5.4/7.2	26.0/30.0	6.0	40/45	40/45
RYBH-24A10J	SINGLE	208/240	1/60	7.2/9.6	34.6/40.0	6.0	60/60	51/58
RYBH-24A15J	SINGLE	208/240	1/60	10.8/14.4	51.9/60.0	6.0	80/90	73/83
RYBH-24A15J	MULTI CKT 1	208/240	1/60	3.6/4.8	17.3/20.0	6.0	30/35	30/33
RYBH-24A15J	MULTI CKT 2	208/240	1/60	7.2/9.6	34.6/40.0	0.0	45/50	44/50
RYBH-24A18J	SINGLE	208/240	1/60	12.8/17.0	61.2/70.8	6.0	90/100	84/96
RYBH-24A18J	MULTI CKT 1	208/240	1/60	6.4/8.5	30.8/35.4	6.0	50/60	46/52
RYBH-24A18J	MULTI CKT 2	208/240	1/60	6.4/8.5	30.8/35.4	0.0	40/45	39/45
RYBH-24A20J	SINGLE	208/240	1/60	14.4/19.2	69.2/80.0	6.0	100/110	94/108
RYBH-24A20J	MULTI CKT 1	208/240	1/60	7.2/9.6	34.6/40.0	6.0	60/60	51/58
RYBH-24A20J	MULTI CKT 2	208/240	1/60	7.2/9.6	34.6/40.0	0.0	45/50	44/50
RYBH-24A07C	SINGLE	208/240	3/60	5.4/7.2	15.0/17.3	6.0	30/30	27/30
RYBH-24A10C	SINGLE	208/240	3/60	7.2/9.6	20.0/23.1	6.0	35/40	33/37
RYBH-24A15C	SINGLE	208/240	3/60	10.8/14.4	30.0/34.6	6.0	45/60	45/51
RYBH-24A18C	SINGLE	208/240	3/60	12.4/17.0	35.6/41.0	6.0	60/60	52/59
RYBH-24A18C	MULTI CKT 1	208/240	3/60	6.4/8.5	17.8/20.5	6.0	30/35	30/34
RYBH-24A18C	MULTI CKT 2	208/240	3/60	6.4/8.5	17.8/20.5	0.0	25/30	23/26
RYBH-24A20C	SINGLE	208/240	3/60	14.2/19.2	40.0/46.2	6.0	60/70	58/66
RYBH-24A20C	MULTI CKT 1	208/240	3/60	7.2/9.6	20.0/23.1	6.0	35/40	33/37
RYBH-24A20C	MULTI CKT 2	208/240	3/60	7.2/9.6	20.0/23.1	0.0	25/30	25/29

S = SINGLE CIRCUIT/CIRCUIT SIMPLE M = MULTIPLE CIRCUIT/CIRCUIT MULTIPLE

INDOOR BLOWER MOTOR LOAD INCLUDED IN CIRCUIT # 1 OR TOTAL SUPPLY WIRE MUST BE RATED AT 75°C MINIMUM COPPER CONDUCTORS ONLY. TEST EXTERNAL STATIC RANGE .1 TO .5 IN. W.C. (HEAT PUMP & ELECTRIC HEAT).

UNITS WITH ELECTRIC HEATERS: CLEARANCE TO COMBUSTIBLE MATERIAL TO BE 0 IN. TO UNIT CASING AND 0 IN. TO PLENUM AND DUCT FOR FIRST 36 IN. MODELS HAVE INTEGRAL CIRCUIT BREAKERS WHICH PROVIDE SUPPLEMENTARY OVERCURRENT PROTECTION AND SERVE AS A MAINTENANCE "DISCONNECT". SUPPLY CIRCUIT NOT TO EXCEED 120 VOLTS TO GROUND ON SINGLE PHASE UNITS. REPLACE LINE SIDE BREAKER COVER(S) AFTER MAKING WIRING CONNECTIONS TO BREAKER(S). IF BLOWER-CONTROL ASSEMBLY REQUIRES REMOVAL, SEE "WARNING HAZARDOUS VOLTAGE".

CHARGEMENT DU MOTEUR SOUFFLEUR INTERNE INCLUS DANS LE CIRCUIT # 1 OU CAPACITÉ DU CÂBLAGE D'ALIMENTATION TOTAL DOIT ÊTRE DE 75C DU MINIMUM DE CONDUCTEURS DE CUIVRE SEULEMENT. TESTER L'INTERVALLE STATIQUE EXTERNE : 1 À 5 PO W.C (THERMOPOMPE ET CHAUFFAGE ÉLECTRIQUE)

UNITÉS AVEC CHAUFFAGES ÉLECTRIQUES : LE DÉGAGEMENT AUX MATIÈRES COMBUSTIBLES DOIT ÊTRE DE 0 po AU BOITIER DE L'UNITÉ ET DE 0 po AU PLÉNUM ET CONDUIT POUR LES 36 PREMIERS po. LES MODÈLES DISPOSENT DE DISJONCTEURS INTÉGRÉS QUI FOURNISSENT UNE PROTECTION SUPPLÉMENTAIRE DE SURINTENSITÉ DE COURANT ET SERVENT DE « SECTIONNEUR » D'ENTRETIEN. LE CIRCUIT D'ALIMENTATION NE DOIT PAS DÉPASSER 120 VOLTS JUSQU'AU SOL SUR DES UNITÉS MONOPHASÉES. REMPLACER LE(S) COUVERCLE(S) DU DISJONCTEUR DU CÔTÉ SECTEUR APRÈS AVOIR EFFECTUÉ LA CONNEXION DES CÂBLAGES AU(X) DISJONCTEUR(S). SI L'ASSEMBLAGE DE CONTRÔLE DU VENTILATEUR A BESOIN D'ÊTRE DÉSASSEMBLÉ, CONSULTER L'AVERTISSEMENT DE TENSION DANGEREUSE

If a heater kit is listed both Single and Multi-circuit, the kit is shipped as a Multi-circuit and will require a single point kit

Contractor should "mark or check" the left column for the kit installed

These are the required maximum and minimum circuit breaker sizes for overcurrent protection and should not be confused with the size of the breakers installed in the heater kit.

Only listed kits can be applied

Heater Kit Supplemental Information: What allows the manufacturer to use standard Circuit Breakers up to 60 amps inside the air handler, when using an approved Heater Kit?

National Electric Code (Section 424-22b) and our UL requirements allow us to subdivide heating element circuits, of less than 48 amps, using breakers of not more than 60 amps and, additionally by, NEC 424-3b, a rating not less than 125 percent of the load and NEC 424-22c, which describes the supplementary overcurrent protection required to be factory-installed within, or on the heater. The breakers in the heater kit are not, and have never been, by NEC, intended to protect power wiring leading to the air handler unit. The breakers in the heating kit are for short circuit protection. All internal unit wiring, where the breakers apply, has been UL approved for short circuit protection.

Ampacity, (not breaker size), determines supply circuit wire size. The ampacity listed on the unit rating plate and the Maximum and Minimum circuit breaker size (noted above) or in the units specification sheet or installation instructions provides the information to properly select wire and circuit breaker/protector size. The National Electric Code (NEC) specifies that the supply or branch circuit must be protected at the source.

5.0 AIRFLOW PERFORMANCE

Airflow performance data is based on cooling performance with a coil and no filter in place. Select performance table for appropriate unit size, voltage and number of electric heaters to be used. Make sure external static applied to unit allows operation within the minimum and maximum limits shown in table below for both cooling and electric heat operation. For optimum blower performance, operate the unit in the .3 to .7 in W.C. external static range. Units with coils should be applied with a minimum of .1 in W.C. external static.

5.1 AIRFLOW OPERATING LIMITS

Cabinet Width	17		17/21		21		24	
Cooling BTUH x 1,000 Cooling Tons Nominal	18 1.5	24 2	30 2.5	36 3	42 3.5	48 4	48 4	60 5
Heat Pump or Air Conditioning Maximum Heat/Cool CFM [L/s] (37.5 CFM [18 L/s]/1,000 BTUH) (450 CFM [212 L/s]/Ton Nominal)	675 [319]	900 [425]	1125 [531]	1350 [637]	1575 [743]	1800 [850]	1800 [850]	1930 [911]
Heat Pump or Air Conditioning Nominal Heat/Cool CFM [L/s] (33.3 CFM [16 L/s]/1,000 BTUH) (400 CFM [189 L/s]/Ton Nominal)	600 [283]	800 [378]	1000 [472]	1200 [566]	1400 [661]	1600 [755]	1600 [755]	1800 [850]
Heat Pump or Air Conditioning Minimum Heat/Cool CFM [L/s] (30.0 CFM [14 L/s]/1,200 BTUH) (360 CFM [170 L/s]/Ton Nominal)	540 [255]	720 [340]	900 [425]	1080 [510]	1260 [595]	1440 [680]	1440 [680]	1620 [765]
Maximum kW Electric Heating & Minimum Electric Heat CFM [L/s]	13 487 [230]	13 617 [291]	18 814 [384]	18 1054 [497]	20 1171 [553]	25 1502 [709]	25 1502 [709]	30 1666 [786]
Maximum Electric Heat Rise °F [°C]	80 [26.7]	63 [17.2]	66 [18.9]	51 [10.6]	49 [9.4]	50 [10]	50 [10]	54 [12.2]

5.2 115/208/240/480V AIRFLOW PERFORMANCE DATA – (-)H1T (CONSTANT TORQUE MOTOR)

Model Number (-)H1T	Tonnage Application	Motor Speed From Factory	Manufacturer Recommended Air Flow Range (Min / Max) CFM	Blower Size/ Motor H.P. # of Speeds	Motor Speed	CFM[L/s] Air Delivery/RPM/Watts (No Filter)							
						External Static Pressure-Inches W.C.							
						0.10 [.02]	0.20 [.05]	0.30 [.07]	0.40 [.10]	0.50 [.12]	0.60 [.15]	0.70 [.17]	
2417ST No Heat	1.5	5	683/485	10x8 1/3 [249] 5 Speed	2	CFM	837	713	608	554	485	—	—
						RPM	565	587	630	692	751	—	—
						Watts	95	81	88	74	66	—	—
					3	CFM	—	—	—	—	683	615	572
						RPM	—	—	—	—	789	842	892
						Watts	—	—	—	—	140	159	155
2417ST with 13kw Heater	1.5	5	683/485	10x8 1/3 [249] 5 Speed	2	CFM	814	692	589	535	467	—	—
						RPM	592	613	656	719	778	—	—
						Watts	108	90	97	82	73	—	—
					3	CFM	—	—	—	—	808	629	584
						RPM	—	—	—	—	789	842	892
						Watts	—	—	—	—	148	168	163
2417ST No Heat	2	5	858/697	10x8 1/3 [249] 5 Speed	4	CFM	902	846	788	742	679	—	—
						RPM	596	645	694	741	791	—	—
						Watts	105	108	116	121	130	—	—
					5	CFM	—	—	—	—	858	816	770
						RPM	—	—	—	—	834	879	925
						Watts	—	—	—	—	185	182	214
2417ST with 13kw Heater	2	5	683/485	10x8 1/3 [249] 5 Speed	4	CFM	882	827	769	723	661	—	—
						RPM	595	670	719	767	817	—	—
						Watts	113	125	124	129	197	—	—
					5	CFM	—	—	—	—	833	791	746
						RPM	—	—	—	—	852	898	944
						Watts	—	—	—	—	192	189	222
3617ST No heater	2.5	5	935/1084 CFM [441/512 L/s]	10x8 1/2 [373] 5 Speed	2	CFM	1093 [516]	1050 [496]	1017 [480]	977 [461]	935 [441]	—	—
						RPM	671	725	764	809	852	—	—
						Watts	153	168	174	180	188	—	—
					3	CFM	—	—	—	—	1084 [512]	1040 [491]	1001 [472]
						RPM	—	—	—	—	896	936	971
						Watts	—	—	—	—	249	257	261
3617ST with 18kw heater	2.5	5	910/1059 CFM [429/500 L/s]	10x8 1/2 [373] 5 Speed	2	CFM	1068 [504]	1025 [484]	992 [468]	952 [449]	910 [429]	—	—
						RPM	711	765	804	849	892	—	—
						Watts	164	179	185	191	199	—	—
					3	CFM	—	—	—	—	1059 [500]	1015 [479]	976 [461]
						RPM	—	—	—	—	936	976	1011
						Watts	—	—	—	—	260	268	272
3617ST No heater	3.0	5	1130/1275 CFM [533/602 L/s]	10x8 1/2 [373] 5 Speed	4	CFM	1270 [599]	1237 [584]	1199 [566]	1165 [550]	1130 [533]	—	—
						RPM	775	816	846	882	926	—	—
						Watts	237	249	259	268	277	—	—
					5	CFM	—	—	—	—	1275 [602]	1244 [587]	1211 [571]
						RPM	—	—	—	—	963	999	1029
						Watts	—	—	—	—	338	348	363

5.2 115/208/240/480V AIRFLOW PERFORMANCE DATA – (-)H1T (CONSTANT TORQUE MOTOR) - continued

Model Number (-)H1T	Tonnage Application	Motor Speed From Factory	Manufacturer Recommended Air Flow Range (Min / Max) CFM	Blower Size/ Motor H.P. # of Speeds	Motor Speed	CFM[L/s] Air Delivery/RPM/Watts (No Filter)							
						External Static Pressure-Inches W.C.							
							0.10 [.02]	0.20 [.05]	0.30 [.07]	0.40 [.10]	0.50 [.12]	0.60 [.15]	0.70 [.17]
3617ST with 18kw heater	3.0	5	1105/1250 CFM [521/590 L/s]	10x8 1/2 [373] 5 Speed	4	CFM	1245 [588]	1212 [572]	1174 [554]	1140 [538]	1105 [521]	—	—
						RPM	815	856	886	922	966	—	—
						Watts	248	260	270	279	288	—	—
					5	CFM	—	—	—	—	1250 [590]	1219 [575]	1186 [560]
						RPM	—	—	—	—	1003	1039	1069
						Watts	—	—	—	—	349	359	374
3621MT No Heater	2.5	5	854/1103 CFM [403/521 L/s]	10x10 1/2 HP 5 Speed	2	CFM	1073	1016	963	906	854	—	—
						RPM	637	692	746	801	847	—	—
						Watts	130	142	153	165	176	—	—
					3	CFM	—	—	—	—	1103	1059	1000
						RPM	—	—	—	—	917	957	1001
						Watts	—	—	—	—	262	271	285
3621MT with 18kW Heater	2.5	5	828/1016 CFM [391/480 L/s]	10x10 1/2 HP 5 Speed	2	CFM	1044	988	936	880	828	—	—
						RPM	678	734	791	844	883	—	—
						Watts	141	155	158	171	182	—	—
					3	CFM	—	—	—	—	1016	961	904
						RPM	—	—	—	—	939	968	1015
						Watts	—	—	—	—	233	243	265
3621MT No Heater	3 & 3.5	5	1070/1288 CFM [505/608 L/s]	10x10 1/2 HP 5 Speed	4	CFM	1264	1223	1171	1112	1070	—	—
						RPM	724	761	814	868	900	—	—
						Watts	198	208	222	237	245	—	—
					5	CFM	—	—	—	—	1288	1244	1200
						RPM	—	—	—	—	974	1012	1044
						Watts	—	—	—	—	345	362	371
3621MT with 18kW Heater	3 & 3.5	5	1042/1257 CFM [492/593 L/s]	10x10 1/2 HP 5 Speed	4	CFM	1233	1193	1142	1084	1042	—	—
						RPM	750	794	845	915	933	—	—
						Watts	219	215	227	251	261	—	—
					5	CFM	—	—	—	—	1257	1213	1169
						RPM	—	—	—	—	1020	1023	1054
						Watts	—	—	—	—	355	368	376
4821ST No heater	3.5	5	1337/1447 CFM [631/683 L/s]	10x10 3/4 [559] 5 Speed	2	CFM	1473 [695]	1442 [681]	1401 [661]	1373 [648]	1337 [631]	—	—
						RPM	781	825	867	905	949	—	—
						Watts	257	271	303	307	315	—	—
					3	CFM	—	—	—	—	1447 [683]	1433 [676]	1402 [662]
						RPM	—	—	—	—	987	1034	1065
						Watts	—	—	—	—	394	406	405
4821ST with 20kw heater	3.5	5	1297/1333 CFM [612/629 L/s]	10x10 3/4 [559] 5 Speed	2	CFM	1433 [676]	1402 [662]	1361 [642]	1333 [629]	1297 [612]	—	—
						RPM	831	875	919	954	989	—	—
						Watts	277	295	313	319	325	—	—
					3	CFM	—	—	—	—	1333 [629]	1300 [613]	1267 [598]
						RPM	—	—	—	—	1011	1046	1080
						Watts	—	—	—	—	350	364	377
4821ST No heater	4.0	5	1535/1654 CFM [724/781 L/s]	10x10 3/4 [559] 5 Speed	4	CFM	1665 [786]	1631 [770]	1601 [756]	1572 [742]	1535 [724]	—	—
						RPM	853	893	934	968	1015	—	—
						Watts	351	387	401	406	422	—	—
					5	CFM	—	—	—	—	1654 [781]	1624 [766]	1563 [738]
						RPM	—	—	—	—	1036	1078	1095
						Watts	—	—	—	—	500	513	523
4821ST with 25kw heater	4.0	5	1495/1614 CFM [706/762 L/s]	10x10 3/4 [559] 5 Speed	4	CFM	1625 [767]	1591 [751]	1561 [737]	1532 [723]	1495 [706]	—	—
						RPM	894	932	970	1020	1052	—	—
						Watts	389	400	410	430	450	—	—
					5	CFM	—	—	—	—	1614 [762]	1584 [748]	1523 [719]
						RPM	—	—	—	—	1085	1090	1105
						Watts	—	—	—	—	514	520	530

5.2 115/208/240/480V AIRFLOW PERFORMANCE DATA – (-)H1T (CONSTANT TORQUE MOTOR) - continued

Model Number (-)H1T	Tonnage Application	Motor Speed From Factory	Manufacturer Recommended Air Flow Range (Min / Max) CFM	Blower Size/ Motor H.P. # of Speeds	Motor Speed	CFM[L/s] Air Delivery/RPM/Watts (No Filter)							
						External Static Pressure-Inches W.C.							
						0.10 [.02]	0.20 [.05]	0.30 [.07]	0.40 [.10]	0.50 [.12]	0.60 [.15]	0.70 [.17]	
4824ST No heater	4.0	3	1545/1732 CFM [729/817 L/s]	11x11 3/4 [559] 5 Speed	2	CFM	1748 [825]	1669 [788]	1639 [773]	1599 [755]	1545 [729]	—	—
						RPM	660	698	734	762	795	—	—
						Watts	297	311	326	340	353	—	—
					3	CFM	—	—	—	—	1732 [817]	1683 [794]	1630 [769]
						RPM	—	—	—	—	840	872	899
						Watts	—	—	—	—	448	467	480
4824ST with 25kw heater	4.0	3	1505/1692 CFM [710/798 L/s]	11x11 3/4 [559] 5 Speed	2	CFM	1708 [806]	1629 [769]	1599 [755]	1559 [736]	1505 [710]	—	—
						RPM	680	736	760	790	820	—	—
						Watts	305	330	341	350	361	—	—
					3	CFM	—	—	—	—	1692 [798]	1643 [775]	1590 [750]
						RPM	—	—	—	—	865	890	1014
						Watts	—	—	—	—	460	470	481
6024ST No heater	5.0	5	1739/1905 CFM [821/899 L/s]	11x11 3/4 [559] 5 Speed	4	CFM	1902 [898]	1862 [879]	1809 [854]	1781 [840]	1739 [821]	—	—
						RPM	712	749	787	815	856	—	—
						Watts	389	409	419	432	459	—	—
					5	CFM	—	—	—	—	1905 [899]	1866 [881]	1832 [865]
						RPM	—	—	—	—	894	924	950
						Watts	—	—	—	—	565	570	592
6024ST with 30kw heater	5.0	5	1699/1865 CFM [802/880 L/s]	11x11 3/4 [559] 5 Speed	4	CFM	1862 [879]	1822 [860]	1769 [835]	1741 [822]	1699 [802]	—	—
						RPM	750	790	810	850	880	—	—
						Watts	410	420	430	455	479	—	—
					5	CFM	—	—	—	—	1865 [880]	1826 [862]	1792 [846]
						RPM	—	—	—	—	920	945	970
						Watts	—	—	—	—	565	587	610
6024ST No Heater	4 & 5	5	1517/1697 CFM [716/801 L/s]	11x11 3/4 [559] 5 Speed	2	CFM	1705 [805]	1661 [784]	1632 [770]	1572 [742]	1517 [716]	—	—
						RPM	663	701	741	782	819	—	—
						Watts	292	309	321	343	357	—	—
					3	CFM	—	—	—	—	1697 [801]	1646 [777]	1601 [756]
						RPM	—	—	—	—	857	895	920
						Watts	—	—	—	—	447	466	473
6024ST with 30kW Heater	4 & 5	5	1482/1661 CFM [700/784 L/s]	11x11 3/4 [559] 5 Speed	2	CFM	1669 [788]	1625 [767]	1596 [753]	1537 [725]	1482 [700]	—	—
						RPM	698	739	763	816	842	—	—
						Watts	308	317	329	361	373	—	—
					3	CFM	—	—	—	—	1661 [784]	1611 [760]	1566 [739]
						RPM	—	—	—	—	882	915	939
						Watts	—	—	—	—	447	480	487

NOTE:

Constant torque motor speed changes

All constant torque motors have 5 speed tabs. Speed tab 1 is for continuous fan. Speed tab 2 (low static) and Speed tab 3 (high static) are for lower tonnage. Speed tab 4 (low static) and Speed tab 5 (high static) are for higher tonnage.

Constant torque air handlers are always shipped from factory at speed tab 5, except for -4824, which is set at speed tab 3.

The low static Speed tab 2 (lower tonnage) and 4 (higher tonnage) are used for external static below 0.5" WC. The high static Speed tab 3 (lower tonnage) and 5 (higher tonnage) are used for external static exceeding 0.5" WC. Move the blue wire to the appropriate speed tab as required by the application needs.

- The airflow for continuous fan (Speed tab 1) is always set at 50% of the Speed tab 4.
- The above airflow table lists the airflow information for air handlers without heater and air handler with maximum heater allowed for each model.
- The following formula can be used to calculate the approximate airflow, if a smaller (N kw) than the maximum heater kit is installed.
Approximate Airflow = Airflow without heater - (Airflow without heater - Airflow with maximum heater) X (N kw/maximum heater kw)

5.2 115/208/240/480V AIRFLOW PERFORMANCE DATA – (-)H1T (CONSTANT TORQUE MOTOR) - continued

Model Number (-)H1T	Nominal Cooling Capacity Tons	Manufacturer Recommended Air Flow Range (Min / Max) CFM	Blower Size/ Motor H.P. # of Speeds	Motor Speed From Factory	Motor Speed	X-13							
						CFM wet Delivery/filter/heaters/RPM/Watts							
						External Static Pressure-Inches W.C.							
							0.10 [.02]	0.20 [.05]	0.30 [.07]	0.40 [.10]	0.50 [.12]	0.60 [.15]	0.70 [.17]
3621H No Heat	2.5		10x10 1/2 HP [373] 2 Speed dual voltage	5	3	CFM	1305	1251	1205	1154	1101	1046	995
						RPM	668	727	752	797	832	888	914
						Watts	193	187	183	208	210	213	247
					2	CFM	1249	1193	1138	1082	1026	970	914
						RPM	732	780	828	877	925	973	1021
						Watts	114	123	133	142	151	161	170
3621H 18 Kw Heat	2.5		10x10 1/2 Hp [373] 2 Speed dual voltage	5	3	CFM	1280	1228	1176	1124	1072	1020	968
						RPM	695	736	777	817	858	899	939
						Watts	189	191	197	208	223	243	267
					2	CFM	1221	1166	1110	1054	998	942	886
						RPM	756	804	853	901	949	997	1045
						Watts	119	128	137	147	156	165	175
3621H No Heat	3		10x10 1/2 Hp [373] 2 Speed dual voltage	5	4	CFM	1468	1421	1377	1332	1285	1240	1192
						RPM	739	773	822	863	901	937	974
						Watts	238	268	276	307	313	302	297
					5	CFM	1272	1220	1174	1124	1067	1016	961
						RPM	658	706	753	797	838	877	925
						Watts	180	189	189	190	225	202	246
3621H 18 Kw Heat	3		10x10 1/2 Hp [373] 2 Speed dual voltage	5	5	CFM	1445	1399	1354	1308	1262	1216	1170
						RPM	759	799	839	878	918	958	997
						Watts	252	277	295	305	308	303	290
					4	CFM	1249	1197	1145	1093	1042	990	938
						RPM	684	728	772	816	859	903	947
						Watts	183	186	192	202	214	230	248
4821M No Heat	3.5		10x10 3/4 Hp [559] 2 Speed dual voltage	5	3	CFM	1590	1546	1512	1476	1443	1412	1378
						RPM	831	878	909	953	982	1012	1049
						Watts	377	373	379	390	406	420	427
					2	CFM	1489	1441	1401	1359	1316	1278	1231
						RPM	750	801	843	882	904	943	985
						Watts	244	270	282	277	288	288	290
4821M 20 Kw Heat	3.5		10x10 3/4 Hp [559] 2 Speed dual voltage	5	3	CFM	1567	1532	1497	1462	1427	1393	1358
						RPM	856	892	927	963	998	1034	1069
						Watts	374	379	386	396	408	423	440
					2	CFM	1465	1423	1381	1338	1296	1254	1212
						RPM	779	816	854	891	929	967	1004
						Watts	257	270	281	287	290	289	285
4821M No Heat	4		10x10 3/4 Hp [559] 2 Speed dual voltage	5	5	CFM	1803	1760	1217	1683	1648	1612	1576
						RPM	886	919	952	988	1019	1053	1088
						Watts	437	430	451	487	489	505	481
					4	CFM	1681	1641	1598	1564	1528	1494	1452
						RPM	825	855	907	940	956	1010	1045
						Watts	338	358	388	397	388	422	434
4821M 20 Kw Heat	4		10x10 3/4 Hp [559] 2 Speed dual voltage	5	5	CFM	1779	1742	1704	1667	1630	1592	1555
						RPM	903	936	970	1003	1037	1070	1104
						Watts	440	451	463	474	486	497	509
					4	CFM	1659	1621	1584	1546	1509	1471	1434
						RPM	843	879	916	952	988	1025	1061
						Watts	352	367	382	397	412	427	442
6021S No Heat	4 & 5		10x10 3/4 Hp [559] 2 Speed dual voltage	5	3	CFM	1841	1798	1758	1728	1699	1660	1629
						RPM	898	930	967	997	1027	1057	1092
						Watts	469	470	484	490	498	512	531
					2	CFM	1716	1669	1631	1594	1555	1522	1483
						RPM	861	887	911	948	984	1015	1050
						Watts	359	375	379	397	427	419	427
6021S 30 Kw Heat	4 & 5		10x10 3/4 Hp [559] 2 Speed dual voltage	5	3	CFM	1817	1783	1748	1713	1679	1644	1609
						RPM	915	947	979	1011	1043	1076	1108
						Watts	470	476	484	494	507	521	538
					2	CFM	1691	1653	1615	1577	1538	1500	1462
						RPM	871	903	935	967	999	1031	1063
						Watts	367	379	392	404	416	428	440
6021S No Heat	5		10x10 3/4 Hp [559] 2 Speed dual voltage	5	5	CFM	2042	2003	1968	1931	1903	1868	1835
						RPM	962	994	1043	1050	1102	1135	1159
						Watts	612	632	616	649	673	657	711
					4	CFM	1886	1849	1809	1776	1741	1704	1677
						RPM	917	948	981	1012	1047	1076	1108
						Watts	491	501	509	525	540	560	569
6021S 30 Kw Heat	5		10x10 3/4 Hp [559] 2 Speed dual voltage	5	5	CFM	2021	1987	1953	1918	1884	1850	1816
						RPM	980	1014	1047	1080	1113	1147	1180
						Watts	618	625	636	650	668	690	715
					4	CFM	2004	1970	1936	1901	1867	1833	1799
						RPM	997	1030	1064	1097	1130	1163	1196
						Watts	617	633	649	666	682	698	714

5.3 240V AIRFLOW PERFORMANCE DATA – (-)H2T (CONSTANT TORQUE MOTOR)

Model Number (-)H2T	Nominal Cooling Capacity Tons	Motor Speed From Factory	Manufacturer Recommended Air Flow Range (Min / Max) CFM	Blower Size/ Motor HP # of Speeds	Y1, Y2 Speed	Motor Speed	CFM Air Delivery/RPM/Watts (No Filter)											
							External Static Pressure-Inches W.C.											
								0.10	0.20	0.30	0.40	0.50	0.60	0.70	0.80	0.90	1.00	
2421MT No Heater	2.0	Y1 tap 4 Y2 tap 5	Y1=310/8 17 CFM [146/385] L/s Y2=445/9 51 CFM [210/448] L/s	10X8 1/3 hp 5 speed	Y1 Low Static	Tap 2	CFM	740	569	310	—	—	—	—	—	—	—	—
							RPM	542	561	584	—	—	—	—	—	—	—	—
							Watts	94	72	49	—	—	—	—	—	—	—	—
						Tap 3	CFM	851	704	653	590	541	489	445	—	—	—	—
							RPM	578	599	647	711	770	814	868	—	—	—	—
							Watts	88	93	98	103	108	113	118	—	—	—	—
					Y1 High Static	Tap 4	CFM	817	699	574	515	—	—	—	—	—	—	—
							RPM	573	588	630	702	—	—	—	—	—	—	—
							Watts	97	88	78	69	—	—	—	—	—	—	—
						Tap 5	CFM	951	911	872	824	787	742	691	—	—	—	—
							RPM	622	672	725	772	821	880	922	—	—	—	—
							Watts	134	146	157	168	179	191	202	—	—	—	—
2421MT With 13 kW Heater	2.0	Y1 tap 4 Y2 tap 5	Y1=290/7 97 CFM [136/376] L/s Y2=425/9 31 CFM [200/439] L/s	10X8 1/3 hp 5 speed	Y1 Low Static	Tap 2	CFM	720	549	290	—	—	—	—	—	—	—	
							RPM	557	576	599	—	—	—	—	—	—	—	—
							Watts	99	77	54	—	—	—	—	—	—	—	—
						Tap 3	CFM	831	684	633	570	521	469	425	—	—	—	—
							RPM	593	614	662	726	785	829	883	—	—	—	—
							Watts	93	98	103	108	113	118	123	—	—	—	—
					Y1 High Static	Tap 4	CFM	797	679	554	495	—	—	—	—	—	—	—
							RPM	588	603	645	717	—	—	—	—	—	—	—
							Watts	102	93	83	74	—	—	—	—	—	—	—
						Tap 5	CFM	931	891	852	804	767	722	671	—	—	—	—
							RPM	637	687	740	787	836	895	937	—	—	—	—
							Watts	139	151	162	173	184	196	207	—	—	—	—
3621MT No Heater	3.0	Y1 tap 4 Y2 tap 5	Y1=434/1 005 CFM [204/474] L/s Y2=703/1 328 CFM [331/626] L/s	10X10 3/4 hp 5 speed	Y1 Low Static	Tap 2	CFM	919	757	596	434	—	—	—	—	—	—	
							RPM	567	584	635	691	—	—	—	—	—	—	—
							Watts	83	79	75	71	67	62	58	54	—	—	—
						Tap 3	CFM	1128	1067	1007	946	885	824	764	703	—	—	—
							RPM	644	691	728	804	884	921	945	986	—	—	—
							Watts	131	142	153	164	175	187	—	—	—	—	—
					Y1 High Static	Tap 4	CFM	1005	942	879	816	753	690	—	—	—	—	—
							RPM	597	645	700	790	830	868	—	—	—	—	—
							Watts	99	108	117	127	136	145	154	164	173	182	—
						Tap 5	CFM	1328	1273	1218	1164	1109	1055	1000	945	891	836	—
							RPM	737	773	815	854	907	990	1040	1065	1085	1117	—
							Watts	197	209	221	233	245	257	269	281	293	305	—
3621MT With 18 kW Heater	3.0	Y1 tap 4 Y2 tap 5	Y1=404/9 75 CFM [190/460] L/s Y2=673/1 298 CFM [317/612] L/s	10X10 3/4 hp 5 speed	Y1 Low Static	Tap 2	CFM	889	727	566	404	—	—	—	—	—	—	
							RPM	592	609	660	716	—	—	—	—	—	—	—
							Watts	88	84	80	76	—	—	—	—	—	—	—
						Tap 3	CFM	1098	1037	977	916	855	794	734	673	—	—	—
							RPM	669	716	753	829	909	946	970	1011	—	—	—
							Watts	136	147	158	169	180	192	5	5	—	—	—
					Y1 High Static	Tap 4	CFM	975	912	849	786	723	660	—	—	—	—	—
							RPM	622	670	725	815	855	893	—	—	—	—	—
							Watts	104	113	122	132	141	150	—	—	—	—	—
						Tap 5	CFM	1298	1243	1188	1134	1079	1025	970	915	861	806	—
							RPM	762	796	840	879	932	1015	1065	1090	1110	1142	—
							Watts	202	214	226	238	250	262	274	286	298	—	—

5.3 240V AIRFLOW PERFORMANCE DATA – (-)H2T (CONSTANT TORQUE MOTOR) - continued

Model Number (-)H2T	Nominal Cooling Capacity Tons	Motor Speed From Factory	Manufacturer Recommended Air Flow Range (Min / Max) CFM	Blower Size/ Motor HP # of Speeds	Y1, Y2 Speed	Motor Speed	CFM Air Delivery/RPM/Watts (No Filter)										
							External Static Pressure-Inches W.C.										
							0.10	0.20	0.30	0.40	0.50	0.60	0.70	0.80	0.90	1.00	
4824MT No Heater	4.0	Y1 tap 4 Y2 tap 5	Y1=702/1 271 CFM [331/599] L/s Y2=992/1 673 CFM [468/489] L/s	11X11 3/4 hp 5 speed	Y1 Low Static	Tap 2	CFM	1196	1046	894	819	702	—	—	—	—	—
							RPM	563	580	598	643	696	—	—	—	—	—
							Watts	133	133	134	135	136	—	—	—	—	—
					Y2 Low Static	Tap 3	CFM	1517	1461	1405	1347	1297	1247	1195	1144	1068	992
							RPM	670	704	735	767	799	832	867	894	940	984
							Watts	251	265	277	287	296	310	322	335	351	365
					Y1 High Static	Tap 4	CFM	1271	1151	1095	1039	968	883	813	745	—	—
							RPM	586	610	650	691	723	774	812	841	—	—
							Watts	164	157	168	180	186	198	211	219	—	—
					Y2 High Static	Tap 5	CFM	1673	1625	1576	1527	1476	1431	1381	1339	1289	1239
							RPM	726	756	783	815	841	870	901	929	956	983
							Watts	329	341	355	370	378	369	405	415	427	441
4824MT With 25 kW Heater	4.0	Y1 tap 4 Y2 tap 5	Y1=672/1 241 CFM [314/582] L/s Y2=962/1 643 CFM [451/772] L/s	11X11 3/4 hp 5 speed	Y1 Low Static	Tap 2	CFM	1166	1016	864	789	672	—	—	—	—	
							RPM	588	605	623	668	721	—	—	—	—	—
							Watts	138	138	139	140	141	—	—	—	—	—
					Y2 Low Static	Tap 3	CFM	1487	1431	1375	1317	1267	1217	1165	1114	1038	962
							RPM	695	729	760	792	824	857	892	919	965	1009
							Watts	256	270	282	292	301	315	327	340	356	370
					Y1 High Static	Tap 4	CFM	1241	1121	1065	1009	938	853	783	715	—	—
							RPM	611	635	675	716	748	799	837	866	—	—
							Watts	169	162	173	185	191	203	216	224	—	—
					Y2 High Static	Tap 5	CFM	1643	1595	1546	1497	1446	1401	1351	1309	1259	1209
							RPM	751	781	808	840	866	895	926	954	981	1008
							Watts	334	346	360	375	383	394	410	420	432	446
6024ST No Heater	5.0	Y1 tap 4 Y2 tap 5	Y1=785/1 350 CFM [370/637] L/s Y2=1249/1 1844 CFM [589/870] L/s	11X11 3/4 hp 5 speed	Y1 Low Static	Tap 2	CFM	1280	1196	1134	1080	1011	945	880	785	—	—
							RPM	591	620	665	710	742	781	818	853	—	—
							Watts	165	170	175	192	200	209	220	231	—	—
					Y2 Low Static	Tap 3	CFM	1686	1632	1586	1538	1491	1447	1400	1352	1298	1249
							RPM	733	770	801	830	863	891	922	953	982	1008
							Watts	334	355	362	370	387	394	411	424	438	450
					Y1 High Static	Tap 4	CFM	1350	1296	1240	1188	1130	1067	1002	931	849	—
							RPM	612	654	695	734	772	811	840	874	908	—
							Watts	179	198	205	225	236	242	253	260	276	—
					Y2 High Static	Tap 5	CFM	1844	1796	1753	1702	1655	1612	1566	1520	1478	1429
							RPM	794	823	852	880	908	938	968	997	1020	1044
							Watts	434	448	460	470	490	502	512	530	540	553
6024ST With 18 kW Heater	5.0	Y1 tap 4 Y2 tap 5	Y1=745/1 310 CFM [353/620] L/s Y2=1209/1 1804 CFM [570/851] L/s	11X11 3/4 hp 5 speed	Y1 Low Static	Tap 2	CFM	1240	1156	1094	1040	971	905	840	745	—	—
							RPM	621	650	695	740	772	811	848	883	—	—
							Watts	170	175	180	197	205	214	225	236	—	—
					Y2 Low Static	Tap 3	CFM	1646	1592	1546	1498	1451	1407	1360	1312	1258	1209
							RPM	763	800	831	860	893	921	952	983	1012	1038
							Watts	339	360	367	375	392	399	416	429	443	455
					Y1 High Static	Tap 4	CFM	1310	1256	1200	1148	1090	1027	962	891	809	—
							RPM	642	684	725	764	802	841	870	904	938	—
							Watts	184	203	210	230	241	247	258	265	281	—
					Y2 High Static	Tap 5	CFM	1804	1756	1713	1662	1615	1572	1526	1480	1438	1389
							RPM	824	853	882	910	938	968	998	1027	1050	1074
							Watts	439	453	465	475	495	507	517	535	545	558

NOTE:

Constant torque motor speed changes

All constant torque motors have 5 speed tabs. Speed tab 1 is for continuous fan. Speed tab 2 (low static) and Speed tab 3 (high static) are for lower tonnage. Speed tab 4 (low static) and Speed tab 5 (high static) are for higher tonnage.

Constant torque air handlers are always shipped from factory at speed tab 5, except for -4824, which is set at speed tab 3.

The low static Speed tab 2 (lower tonnage) and 4 (higher tonnage) are used for external static below 0.5" WC. The high static Speed tab 3 (lower tonnage) and 5 (higher tonnage) are used for external static exceeding 0.5" WC. Move the blue wire to the appropriate speed tab as required by the application needs.

- The airflow for continuous fan (Speed tab 1) is always set at 50% of the Speed tab 4.
- The above airflow table lists the airflow information for air handlers without heater and air handler with maximum heater allowed for each model.
- The following formula can be used to calculate the approximate airflow, if a smaller (N kw) than the maximum heater kit is installed.

$$\text{Approximate Airflow} = \text{Airflow without heater} - (\text{Airflow without heater} - \text{Airflow with maximum heater}) \times (\text{N kw}/\text{maximum heater kw})$$

6.0 DUCTWORK

Field ductwork must comply with the National Fire Protection Association NFPA 90A, NFPA 90B and any applicable local ordinance.

WARNING

Do not, under any circumstances, connect return ductwork to any other heat producing device such as fireplace insert, stove, etc. Unauthorized use of such devices may result in fire, carbon monoxide poisoning, explosion, personal injury or property damage.

Sheet metal ductwork run in unconditioned spaces must be insulated and covered with a vapor barrier. Fibrous ductwork may be used if constructed and installed in accordance with SMACNA Construction Standard on Fibrous Glass Ducts. Ductwork must comply with National Fire Protection Association as tested by U/L Standard 181 for Class I Air Ducts. Check local codes for requirements on ductwork and insulation.

- Duct system must be designed within the range of external static pressure the unit is designed to operate against. It is important that the system airflow be adequate. Make sure supply and return ductwork, grills, special filters, accessories, etc. are accounted for in total resistance. See airflow performance tables in this manual.
- Design the duct system in accordance with “ACCA” Manual “D” Design for Residential Winter and Summer Air Conditioning and Equipment Selection. Latest editions are available from: “ACCA” Air Conditioning Contractors of America, 1513 16th Street, N.W., Washington, D.C. 20036. If duct system incorporates **flexible air duct**, be sure **pressure drop** information (straight length plus all turns) shown in “ACCA” Manual “D” is accounted for in system.
- Supply plenum is attached to the 3/4” duct flanges supplied with the unit. Attach flanges around the blower outlet.

IMPORTANT: If an elbow is included in the plenum close to the unit, it must not be smaller than the dimensions of the supply duct flange on the unit.

- **IMPORTANT:** The front flange on the return duct if connected to the blower casing must not be screwed into the area where the power wiring is located. Drills or sharp screw points can damage insulation on wires located inside unit.
- Secure the supply and return ductwork to the unit flanges, using proper fasteners for the type of duct used and tape the duct-to-unit joint as required to prevent air leaks.

7.0 REFRIGERANT CONNECTIONS

Keep the coil connections sealed until refrigerant connections are to be made. See the Installation Instructions for the outdoor unit for details on line sizing, tubing installation, and charging information.

Coil is shipped with a low (5 - 10 PSIG) pressure charge of dry nitrogen. Evacuate the system before charging with refrigerant.

Install refrigerant tubing so that it does not block service access to the front of the unit.

Nitrogen should flow through the refrigerant lines while brazing.

Make sure to protect TXV, copper to aluminum joint, and service valves from overheating by use of wet rag or some type of shielding. Double tip torches are not recommended.

Use a brazing shield to protect the cabinet’s paint from being damaged by torch flames.

After the refrigerant connections are made, seal the gap around the connections with pressure sensitive gasket. If necessary, cut the gasket into two pieces for a better seal (See Figure 4.)

7.1 TEV SENSING BULB

IMPORTANT: DO NOT perform any soldering with the TEV bulb attached to any line. After soldering operations have been completed, clamp the TEV bulb securely on the suction line at the 10 to 2 o’clock position with the strap provided in the parts bag. Insulate the TEV sensing bulb and suction line with the provided pressure sensitive insulation (size 4” x 7”) and secure with provided wire ties.

IMPORTANT: TEV sensing bulb should be located on a horizontal section of suction line, just outside of coil box. The copper sensing bulb must never be placed on any aluminum tube as this will result in galvanic corrosion and eventual failure of the aluminum tube.

FIGURE 27
BULB LOCATION

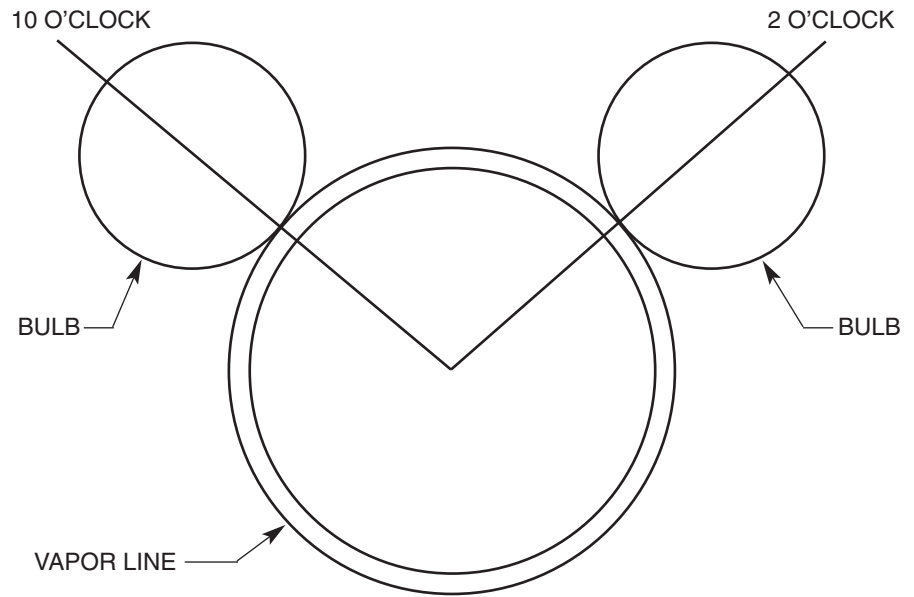
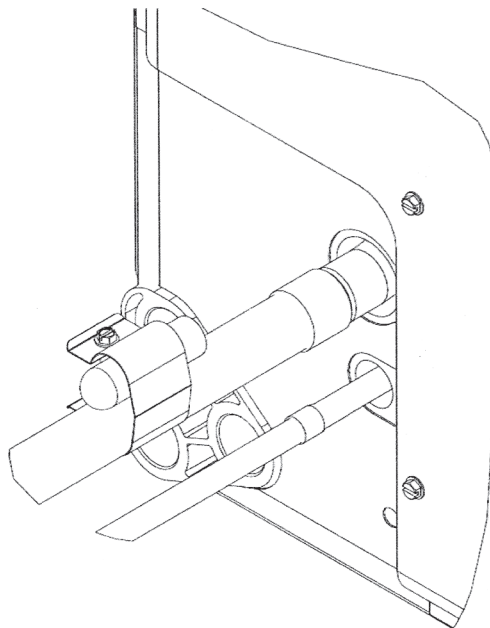

FIGURE 28
BULB LOCATION



7.2 CONDENSATE DRAIN TUBING

Consult local codes or ordinances for specific requirements.

IMPORTANT: When making drain fitting connections to the drain pan, use a thin layer of Teflon paste, silicone or Teflon tape and install hand tight.

IMPORTANT: When making drain fitting connections to drain pan, do not overtighten. Overtightening fittings can split pipe connections on the drain pan.

- Install drain lines so they do not block service access to front of the unit. Minimum clearance of 24 inches is required for filter, coil or blower removal and service access.
- Make sure unit is level or pitched slightly toward primary drain connection so that water will drain completely from the pan. (See Figure 3.)
- Do not reduce drain line size less than connection size provided on condensate drain pan.

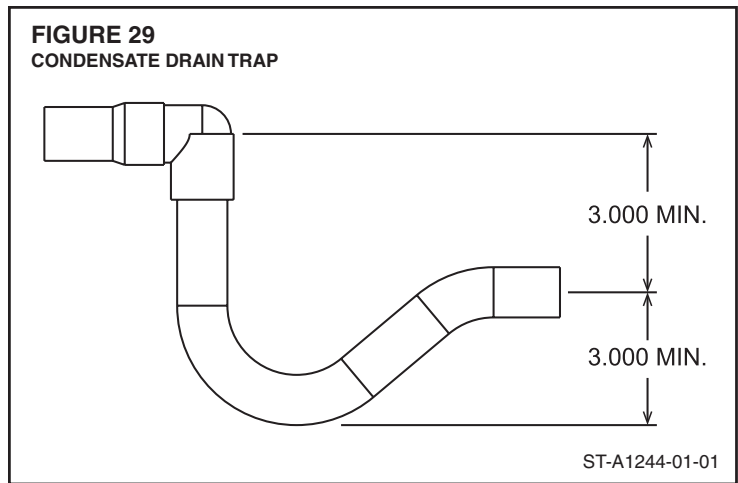

- All drain lines must be pitched downward away from the unit a minimum of 1/8" per foot of line to ensure proper drainage.
- Do not connect condensate drain line to a closed or open sewer pipe. Run condensate to an open drain or outdoors.
- The drain line should be insulated where necessary to prevent sweating and damage due to condensate forming on the outside surface of the line.
- Make provisions for disconnecting and cleaning of the primary drain line should it become necessary. Install a 3 in. trap in the primary drain line as close to the unit as possible. Make sure that the top of the trap is below connection to the drain pan to allow complete drainage of pan (See Figure 3).
- Auxiliary drain line should be run to a place where it will be noticeable if it becomes operational. Occupant should be warned that a problem exists if water should begin running from the auxiliary drain line.
- Plug the unused drain connection with the plugs provided in the parts bag, using a thin layer of teflon paste, silicone or teflon tape to form a water tight seal.
- Test condensate drain pan and drain line after installation is complete. Pour water into drain pan, enough to fill drain trap and line. Check to make sure drain pan is draining completely, no leaks are found in drain line fittings, and water is draining from the termination of the primary drain line.

7.3 DUCT FLANGES

Field-installed duct flanges (4 pieces) are shipped with units. Install duct flanges as needed on top of the unit. (See Figure 3.)

8.0 AIR FILTER (not factory-installed)

- External filter or other means of filtration is required. Units should be sized for a maximum of 300 feet/min. air velocity or that recommended for the type filter installed.

Filter application and placement are critical to airflow, which may affect the heating and cooling system performance. Reduced airflow can shorten the life of the system's major components, such as motor, limits, elements, heat relays, evaporator coil or compressor. Consequently, we recommend that the return air duct system have only one filter location. For systems with a return air filter grill or multiple filter grills, can have a filter installed at each of the return air openings.

If high efficiency filters or electronic air cleaners are used in the system, it is important that the airflow is not reduced to maximize system performance and life. Always verify that the system's airflow is not impaired by the filtering system that has been installed, by performing a temperature rise and temperature drop test.

IMPORTANT: DO NOT DOUBLE FILTER THE RETURN AIR DUCT SYSTEM. DO NOT FILTER THE SUPPLY AIR DUCT SYSTEM.

WARNING

Do not operate the system without filters. A portion of the dust entrained in the air may temporarily lodge in the duct runs and at the supply registers. Any circulated dust particles could be heated and charred by contact with the air handler elements. This residue could soil ceilings, walls, drapes, carpets and other articles in the house.

Soot damage may occur with filters in place, when certain types of candles, oil lamps or standing pilots are burned.

9.0 SEQUENCE OF OPERATION

9.1 COOLING (COOLING ONLY OR HEAT PUMP)

- When the thermostat “calls for cooling,” the circuit between R and G is completed, causing the blower relay (BR) to energize. The N.O. contacts will close, causing the indoor blower motor (IBM) to operate. The circuit between R and Y is also completed: This circuit closes the contactor (CC) in the outdoor unit starting the compressor (COMP) and outdoor fan motor (OFM).

9.2 HEATING (ELECTRIC HEAT ONLY)

- When the thermostat “calls for heat,” the circuit between R and W is completed, and the heater sequencer (HR₁) is energized. The heating elements (HE) and the indoor blower motor (IBM) will come on. Units with a second heater sequencer (HR₂) can be connected with the first sequencer (HR₁) to W on the thermostat sub-base or connected to a second stage W₂ on the sub-base.

9.3 HEATING (HEAT PUMP)

- When the thermostat “calls for heat,” the circuits between R and B, R and Y and R and G are completed. Circuit R and B energizes the reversing valve (RV) switching it to the heating position (remains energized as long as selector switch is in “heat” position). Circuit R and Y energizes the contactor (CC) starting the outdoor fan motor (OFM) and compressor (COMP). Circuit R and G energizes the blower relay (BR) starting the indoor blower motor (IBM).
- If the room temperature should continue to fall, circuit R and W₂ is completed by the second-stage heat room thermostat. Circuit R-W₂ energizes a heat sequencer (HR₁). The completed circuit will energize supplemental electric heat. Units with a second heater sequencer (HR₂) can be connected with first sequencer (HR₁) to W₂ on thermostat or connected to a third heating stage W₂ on the thermostat sub-base. A light on the thermostat indicates when supplemental heat is being energized.

9.4 BLOWER TIME DELAY (HEATING OR COOLING)

- All models are equipped with a blower time delay (BTD) in lieu of a blower relay (BR) (see wiring diagram). The blower will run for 30 seconds after the blower time delay (BTD) is de-energized.

9.5 DEFROST (DEFROST HEAT CONTROL)

- For sequence of operation for defrost controls, see outdoor heat pump installation instructions.
- Supplemental heat during defrost can be provided by connecting the purple (PU) pig-tail in the outdoor unit to the W on the thermostat. This will complete the circuit between R and W through a set of contacts in the defrost relay (DR) when the outdoor heat pump is in defrost. This circuit, if connected, will help prevent cold air from being discharged from the indoor unit during defrost.
- For most economical operation, if cold air is not of concern during defrost, the purple wire can be left disconnected. Supplemental heat will then come on only when called for by second stage room thermostat.

9.6 EMERGENCY HEAT (HEATING HEAT PUMP)

- If selector switch on thermostat is set to the emergency heat position, the heat pump will be locked out of the heating circuit, and all heating will be electric heat. Jumper should be placed between W₂ and E on the thermostat sub-base so that the electric heat control will transfer to the first stage heat on the thermostat. This will allow the indoor blower to cycle on and off with the electric heat when the fan switch is in the auto position.

9.7 ROOM THERMOSTAT (ANTICIPATOR SETTING)

See instructions with outdoor section, condensing unit or heat pump for recommended room thermostats.

- On units with one electric heat sequencer (HR₁) (see wiring diagram on unit), heat anticipator setting should be .16.
- On units with two electric heat sequencers (HR₁ & HR₂) (see wiring diagram on unit), heat anticipator setting should be .32 if both are connected to same stage on thermostat. Setting should be .16 if (HR₁ & HR₂) are connected to separate stages.

NOTE: Some thermostats contain a fixed, non-adjustable heat anticipator. Adjustment is not permitted.

- The thermostat should be mounted 4 to 5 feet above the floor on an inside wall of the living room or a hallway that has good air circulation from the other rooms being controlled by the thermostat. It is essential that there be free air circulation at the location of the same average temperature as other rooms being controlled. Movement of air should not be obstructed by furniture, doors, draperies, etc. The thermostat should not be mounted where it will be affected by drafts, hot or cold water pipes or air ducts in walls, radiant heat from fireplace, lamps, the sun, T.V. or an outside wall. See instruction sheet packaged with thermostat for mounting and installation instructions.

10.0 CALCULATIONS

10.1 CALCULATING TEMPERATURE RISE

- The formula for calculating air temperature rise for electric resistance heat is:

$$\text{Temperature Rise } ^\circ\text{F} = \frac{3.16 \times \text{Watts}}{\text{CFM}}$$

Where: 3.16 = Constant, CFM = Airflow

10.2 CALCULATING BTUH HEATING CAPACITY

- The formula for calculating BTUH heating capacity for electric resistance heat is:

$$\text{BTUH Heating} = \text{Watts} \times 3.412$$

Where: 1 kW = 1000 Watts, 3.412 = Btuh/Watt

10.3 CALCULATING AIRFLOW CFM

- The formula for calculating airflow using temperature rise and heating BTUH for units with electric resistance heat is:

$$\text{CFM} = \frac{\text{Heating BTUH}}{1.08 \times \text{Temp. Rise}}$$

10.4 CALCULATING CORRECTION FACTOR

- For correction of electric heat output (kW or BTUH) or temperature rise at voltages other than rated voltage multiply by the following correction factor:

$$\text{Correction Factor} = \frac{\text{Applied Voltage}^2}{\text{Rated Voltage}^2}$$

11.0 PRE-START CHECKLIST

PRE-START CHECKLIST	
<input type="radio"/> YES <input type="radio"/> NO	Is unit properly located, level, secure and service-able?
<input type="radio"/> YES <input type="radio"/> NO	Has auxiliary pan been provided under the unit with separate drain? (Units installed above a finished ceiling).
<input type="radio"/> YES <input type="radio"/> NO	Is condensate line properly sized, run, trapped, pitched and tested?
<input type="radio"/> YES <input type="radio"/> NO	Is ductwork correctly sized, run, taped and insulated?
<input type="radio"/> YES <input type="radio"/> NO	Have all cabinet openings and wiring been sealed with caulking?
<input type="radio"/> YES <input type="radio"/> NO	Is the filter clean, in place and of adequate size?
<input type="radio"/> YES <input type="radio"/> NO	Is the wiring tight, correct and to the wiring diagram?
<input type="radio"/> YES <input type="radio"/> NO	Is the unit properly grounded and protected (fused)?
<input type="radio"/> YES <input type="radio"/> NO	Is the thermostat heat anticipator been set properly?
<input type="radio"/> YES <input type="radio"/> NO	Is the unit circuit breaker(s) rotated properly "on" up - "off" down?
<input type="radio"/> YES <input type="radio"/> NO	Are the unit circuit breaker(s) line lug cover(s) in place?
<input type="radio"/> YES <input type="radio"/> NO	Are all access panels in place and secure?
Refer to outdoor unit installation instructions for system start-up instructions and refrigerant charging instructions.	

12.0 MAINTENANCE

For continuing high performance, and to minimize possible equipment failure, it is essential that periodic maintenance be performed on this equipment. Consult your local dealer as to the proper frequency of maintenance and the availability of a maintenance contract

IMPORTANT: Before performing any service or maintenance procedures, see the "Safety Information" section at the front of this manual.

WARNING

Units with circuit breaker(s) meet requirements as a service disconnect switch, however, if access is required to the line side (covered) of the circuit breaker, this side of the breaker(s) will be energized with the breaker(s) de-energized. Contact with the line side can cause electrical shock resulting in personal injury or death.

12.1 AIR FILTER (NOT FACTORY-INSTALLED)

Check the system filter every ninety days or as often as found to be necessary and if obstructed, clean or replace at once.

FILTER MAINTENANCE

Have your qualified installer, service agency or HVAC professional instruct you on how to access your filters for regular maintenance.

IMPORTANT: Do not operate the system without a filter in place.

- New filters are available from your local distributor.

12.2 INDOOR COIL - DRAIN PAN - DRAIN LINE

Inspect the indoor coil once each year for cleanliness and clean as necessary. In some cases, it may be necessary to remove the filter and check the return side of the coil with a mirror and flashlight.

IMPORTANT: Do not use caustic household drain cleaners, such as bleach, in the condensate pan or near the indoor coil. Drain cleaners will quickly damage the indoor coil.

12.3 BLOWER MOTOR AND WHEEL

Inspect the blower motor and wheel for cleanliness. It should be several years before it would become necessary to clean the blower motor and wheel.

- If it becomes necessary to remove the blower assembly from the unit, see instructions on removal and disassembly of motor, blower and heater parts.
- The blower motor and wheel may be cleaned by using a vacuum with a soft brush attachment. Remove grease with a mild solvent such as hot water and detergent. Be careful not to disturb the balance weights (clips) on the blower wheel blades. Do not drop or bend wheel as balance will be affected.

12.4 LUBRICATION

The blower motor sleeve bearings are pre-lubricated by the motor manufacturer and do not have oiling ports. Motor should be run for an indefinite period of time without additional lubrication.

12.5 BLOWER ASSEMBLY REMOVAL AND REPLACEMENT

Removing the blower assembly is not required for normal service and maintenance. Removal is necessary for replacement of defective parts such as motor, blower wheel. After extended use, removal of the blower assembly may become necessary for a thorough cleaning of the blower motor and wheel.

WARNING

If removal of the blower assembly is required, all disconnect switches supplying power to the equipment must be de-energized and locked (if not in sight of unit) so the field power wires can be safely removed from the blower assembly. Failure to do so can cause electrical shock resulting in personal injury or death.

- Mark field power supply wiring (for replacement) attached to terminal block or circuit breaker(s) on blower assembly. Remove wiring from terminal block or circuit breaker(s).
- Mark low voltage control wiring (for replacement) where attached to unit control pig-tails on right side of blower housing. Remove wire nuts attaching field control wiring to unit control pigtails.
- Remove 4 screws holding blower assembly to front channel of cabinet and pull blower assembly from cabinet.
- To replace blower assembly, slide blower assembly into blower deck. Make sure blower assembly engages lances in deck properly. If assembly hangs up, check to make sure top and bottom are lined up in proper locations.
- Slide blower assembly to back of cabinet and make sure it is completely engaged.
- Replace 4 screws holding blower assembly to front channel of cabinet. Take care not to strip screws, just snug into place.
- Replace low voltage control wiring with wire nuts and make sure wiring is to wiring diagram and a good connection has been made.
- Replace field power wiring to terminal block or circuit breaker(s) on control area of blower assembly. Make sure wires are replaced as they were, check wiring diagram if necessary. Tighten supply power wiring securely to terminals lugs.
- Make sure wiring is within cabinet and will not interfere with access door. Make sure proper separation between low voltage control wiring and field power wiring has been maintained.
- Replace blower assembly control access panel before energizing equipment.

12.6 MOTOR REPLACEMENT

With the blower assembly removed, the indoor blower motor can be removed and replaced using the following procedure:

- Remove motor leads from the motor capacitor and blower relay. Note lead locations for ease of reassembly. Pull leads from plastic bushing in blower side.
- Loosen the set screw holding blower wheel onto the motor shaft. Shaft extends through blower hub so that a wrench can be used on the extended shaft to break the shaft loose if necessary. Be careful not to damage shaft. A wheel puller can be used on the groove in the blower hub if necessary.
- Remove 4 metal screws holding motor mounts to blower side and remove motor from blower assembly.
- To install new motor, remove 1 screw holding motor mounts to motor shell and remove mounts (four) from motor.
- Install (four) motor mounts to motor using same screw or screws supplied with replacement motor.

WARNING

To avoid electrical shock which can result in personal injury or death, use only the screws furnished in the motor shell mounting holds. Screws are #8-18 x .25 in. long blunt nose thread forming. Screws longer than 1/4 in. may contact the motor winding.

- To reassemble, insert motor shaft through hub in blower wheel and orient motor to original position with motor leads and motor label to front of blower (control area).
- Reassemble 12 sheet metal screws through motor mounts into blower side. Do not overtorque screws, blower side is light gage sheet metal, just snug screws tight enough to hold motor mounts in position.
- Turn motor shaft so that flat on shaft is located under blower wheel setscrew, and blower wheel is centered in blower housing with the same distance on each side between the inlet venturi and outside of blower wheel. Tighten setscrew on motor shaft. Turn wheel by hand to make sure it runs true without hitting blower sides.
- Reassemble motor wiring to capacitor and blower relay making sure that wires match wiring diagram and are tight and secure.

12.7 BLOWER WHEEL REPLACEMENT

With the blower assembly removed and the motor assembly removed (see above instructions), remove the 4 screws holding the blower wrap (cutoff) to the blower sides.

- With wrap (cutoff) screws removed, cut off end of blower wrap will spring up. Lifting wrap blower wheel is removed through the discharge opening in the blower housing.
- To replace, make sure wheel is oriented properly with hub to the opposite side from the motor. Lift blower wrap and insert blower wheel through discharge opening in the blower housing.
- Hold blower wrap down into position and replace two screws holding blower wrap to blower sides.
- See motor replacement and blower assembly instructions for remaining assembly procedure.

13.0 REPLACEMENT PARTS

Any replacement part used to replace parts originally supplied on equipment must be the same as or an approved alternate to the original part supplied. The manufacturer will not be responsible for replacement parts not designed to physically fit or operate within the design parameters the original parts were selected for.

These parts include but are not limited to: Circuit breakers, heater controls, heater limit controls, heater elements, motor, motor capacitor, blower relay, control transformer, blower wheel, filter, indoor coil and sheet metal parts.

When ordering replacement parts, it is necessary to order by part number and include with the order the complete model number and serial number from the unit data plate. (See parts list for unit component part numbers).

14.0 ACCESSORIES-KITS-PARTS

- **Combustible Floor Base RXHB-** for downflow applications.

Model Cabinet Size	Combustible Floor Base Model Number
17	RXHB-17
21	RXHB-21
24	RXHB-24

- **Jumper Bar Kit 3 Ckt. to 1 Ckt. RXBJ-A31** is used to convert single phase multiple three circuit units to a single supply circuit. Kit includes cover and screw for line side terminals.
- **Jumper Bar Kit 2 Ckt. to 1 Ckt. RXBJ-A21** is used to convert single phase multiple two circuit units to a single supply circuit. Kit includes cover and screw for line side terminals.

NOTE: No jumper bar kit is available to convert three phase multiple two circuit units to a single supply circuit.

- **External Filter Base RXHF- (See Figure 30)**

Model Cabinet Size	Filter Size	Part Number	A	B	
17	16 x 20 [406 x 508]	RXHF-17	Accommodate	15.70	17.50
21	20 x 20 [508 x 508]	RXHF-21	1" or 2"	19.20	21.00
24	25 x 20 [635 x 508]	RXHF-24	filter	22.70	25.50

FIGURE 30
EXTERNAL FILTER BASE: RXHF-

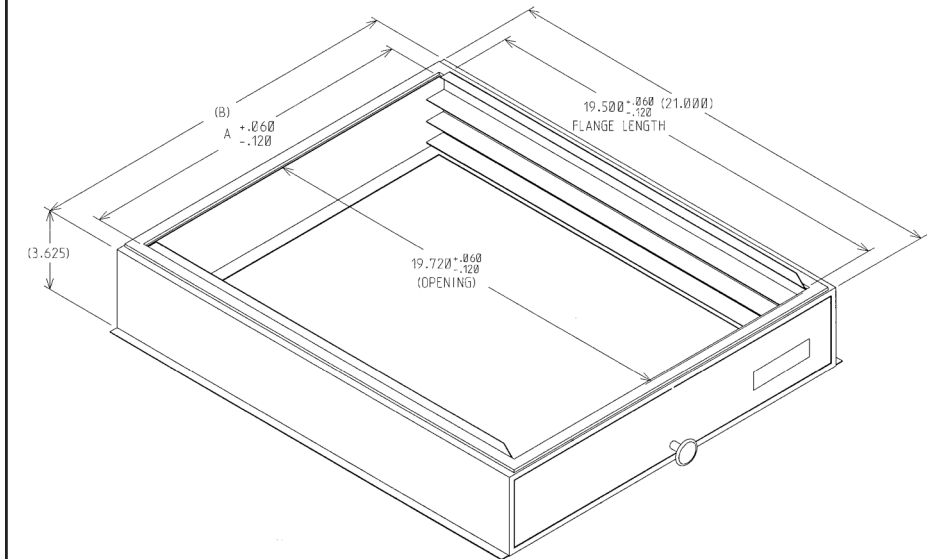

- **Horizontal Adapter Kit RXHH-**

This horizontal adapter kit is used to convert Upflow/Downflow only models to horizontal flow. See the following table to order proper horizontal adapter kit.

Coil Model	Horizontal Adapter Kit Model Number (Single Qty.)	Horizontal Adapter Kit Model Number (10-pak Qty.)
2414	RXHH-A01	RXHH-A01x10
2417	RXHH-A02	RXHH-A02x10
3617/3621	RXHH-A03	RXHH-A03x10
4821/4824	RXHH-A04	RXHH-A04x10
6024	RXHH-A05	RXHH-A05x10
3621H/4821M/6021S	RXHH-A06	RXHH-A06x10

- **Auxiliary Horizontal Overflow Pan RXBM-**

Nominal Cooling Capacity Tons	Auxiliary Horizontal Overflow Pan Accessory Model Number
1½ - 3	RXBM-AC48
3621H 3½ - 5	RXBM-AC61

