

# INSTALL MANUAL

## Air Conditioner

Indoor Unit  
CS-XE15SKUA

Outdoor Unit  
CU-XE15SKUA

Destination  
U.S.A.  
Canada



### WARNING

This service information is designed for experienced repair technicians only and is not designed for use by the general public. It does not contain warnings or cautions to advise non-technical individuals of potential dangers in attempting to service a product. Products powered by electricity should be serviced or repaired only by experienced professional technicians. Any attempt to service or repair the products dealt with in this service information by anyone else could result in serious injury or death.

### IMPORTANT SAFETY NOTICE

There are special components used in this equipment which are important for safety. These parts are marked by  in the Schematic Diagrams, Circuit Board Diagrams, Exploded Views and Replacement Parts List. It is essential that these critical parts should be replaced with manufacturer's specified parts to prevent shock, fire or other hazards. Do not modify the original design without permission of manufacturer.

### PRECAUTION OF LOW TEMPERATURE

In order to avoid frostbite, be assured of no refrigerant leakage during the installation or repairing of refrigerant circuit.

# 11. Installation Instruction

## 11.1 Select the Best Location

### 11.1.1 Indoor Unit

- Do not install the unit in excessive oil fume area such as kitchen, workshop and etc.
- There should not be any heat source or steam near the unit.
- There should not be any obstacles blocking the air circulation.
- A place where air circulation in the room is good.
- A place where drainage can be easily done.
- A place where noise prevention is taken into consideration.
- Do not install the unit near the door way.
- Ensure the spaces indicated by arrows from the wall, ceiling, fence or other obstacles.
- Mount with the lowest moving parts at least 8ft (2.4 m) above floor or grade level.

### 11.1.2 Outdoor Unit

- If an awning is built over the unit to prevent direct sunlight or rain, be careful that heat radiation from the condenser is not obstructed.
- There should not be any animal or plant which could be affected by hot air discharged.
- Keep the spaces indicated by arrows from wall, ceiling, fence or other obstacles.
- Do not place any obstacles which may cause a short circuit of the discharged air.
- If piping length is over the [piping length for additional gas], additional refrigerant should be added as shown in the table.
- Recommended installation height for outdoor unit should be above the seasonal snow level.
- Be careful not to locate outdoor unit directly under a roof line where falling snow or ice can cause damage or dripping water can increase ice accumulation and defrost cycles.

Model	Capacity (Btu/h)	Piping size		Std. Length	Max. Elevation	Min. Piping Length	Max. Piping Length	Additional Refrigerant	Piping Length for add. gas
		Gas	Liquid						
XE15SKUA	15000	1/2" (12.7 mm)	1/4" (6.35 mm)	24.6 ft (7.5 m)	49.2 ft (15 m)	9.8 ft (3 m)	65.6 ft (20 m)	0.3 oz/ft (25 g/m)	24.6 ft (7.5 m)

Example: For XE15SKUA

If the unit is installed at 32.8 ft (10 m) distance, the quantity of additional refrigerant should be 2.46 oz (62.5 g) .... (32.8 - 24.6) ft x 0.3 oz/ft = 2.46 oz. ((10-7.5) m x 25 g/m = 62.5 g)

## 11.1.3 Indoor/Outdoor Unit Installation Diagram

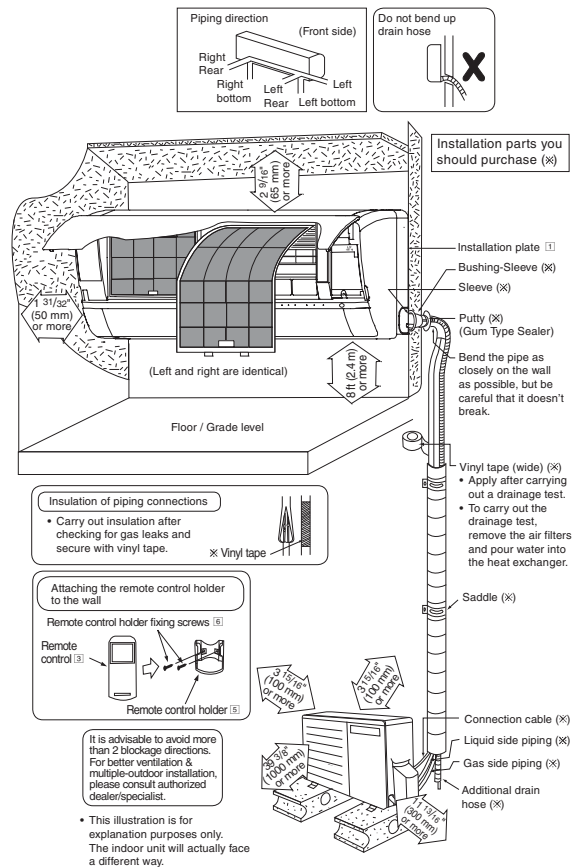

## 11.2 Indoor Unit

The mounting wall shall be strong and solid enough to prevent it from vibration.

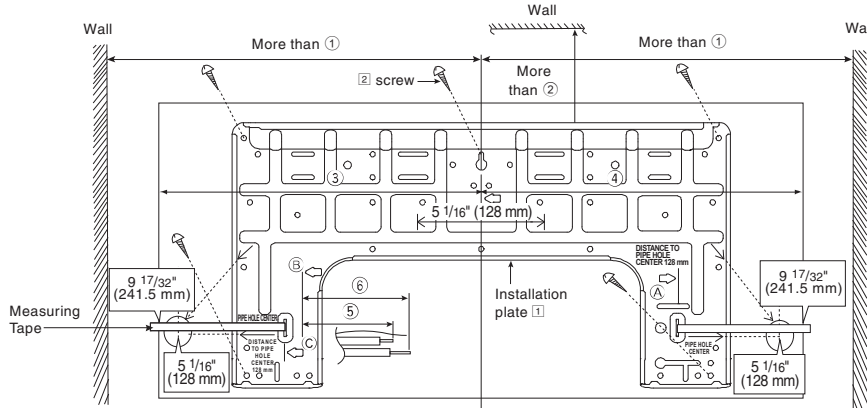

Model	Dimension					
	①	②	③	④	⑤	⑥
XE15SKUA	19-9/32" (490 mm)	3-7/32" (82 mm)	17-9/32" (439 mm)	17" (432 mm)	1-11/16" (43 mm)	3-3/4" (95 mm)

The center of installation plate should be at more than ① at right and left of the wall.

The distance from installation plate edge to ceiling should more than ②.

From installation plate left edge to unit's left side is ③.

From installation plate right edge to unit's right is ④.

Ⓑ : For left side piping, piping connection for liquid should be about ⑤ from this line.

: For left side piping, piping connection for gas should be about ⑥ from this line.

1 Mount the installation plate on the wall with 5 screws or more (at least 5 screws).

(If mounting the unit on the concrete wall, consider using anchor bolts.)

○ Always mount the installation plate horizontally by aligning the marking-off line with the thread and using a level gauge.

2 Drill the piping plate hole with  $\varnothing 2\text{-}3/4"$  ( $\varnothing 70$  mm) hole-core drill.

○ Line according to the left and right side of the installation plate. The meeting point of the extended line is the center of the hole. Another method is by putting measuring tape at position as shown in the diagram above. The hole center is obtained by measuring the distance namely  $5\text{-}1/16"$  (128 mm) for left and right hole respectively.

○ Drill the piping hole at either the right or the left and the hole should be slightly slanting to the outdoor side.

### 11.2.1 To Drill a Hole in the Wall and Install a Sleeve of Piping

1 Insert the piping sleeve to the hole.

2 Fix the bushing to the sleeve.

3 Cut the sleeve until it extrudes about  $19/32"$  (15 mm) from the wall.

#### ⚠ CAUTION

❗ When the wall is hollow, please be sure to use the sleeve for tube assembly to prevent dangers caused by mice biting the connection cable.

4 Finish by sealing the sleeve with putty or caulking compound at the final stage.

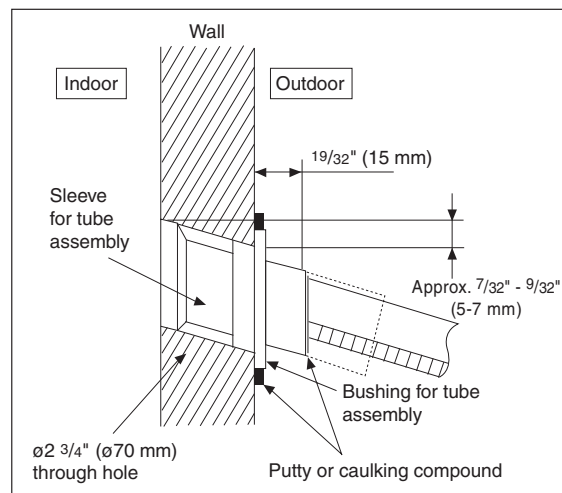

## 11.2.2 Indoor Unit Installation

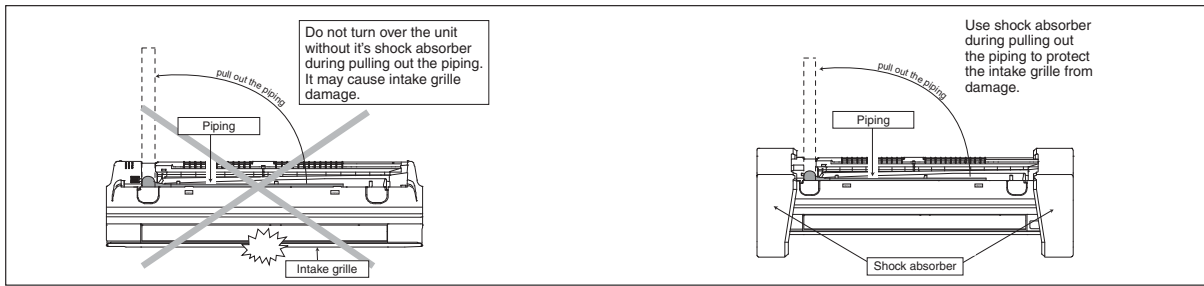

### 11.2.2.1 For the right rear piping

- Step-1** Pull out the Indoor piping
- Step-2** Install the Indoor Unit
- Step-3** Secure the Indoor Unit
- Step-4** Insert the connection cable

### 11.2.2.2 For the right bottom piping

- Step-1** Pull out the Indoor piping
- Step-2** Install the Indoor Unit
- Step-3** Insert the connection cable
- Step-4** Secure the Indoor Unit

### 11.2.2.3 For the embedded piping

- Step-1** Replace the drain hose
- Step-2** Bend the embedded piping
  - Use a spring bender or equivalent to bend the piping so that the piping is not crushed.
- Step-3** Pull the connection cable into Indoor Unit
  - The inside and outside connection cable can be connected without removing the front grille.
- Step-4** Cut and flare the embedded piping
  - When determining the dimensions of the piping, slide the unit all the way to the left on the installation plate.
  - Refer to the section "Cutting and flaring the piping".
- Step-5** Install the Indoor Unit
- Step-6** Connect the piping
  - Please refer to "Connecting the piping" column in outdoor unit section. (Below steps are done after connecting the outdoor piping and gas-leakage confirmation.)
- Step-7** Insulate and finish the piping
  - Please refer to "Insulation of piping connection" column as mentioned in indoor/outdoor unit installation.
- Step-8** Secure the Indoor Unit

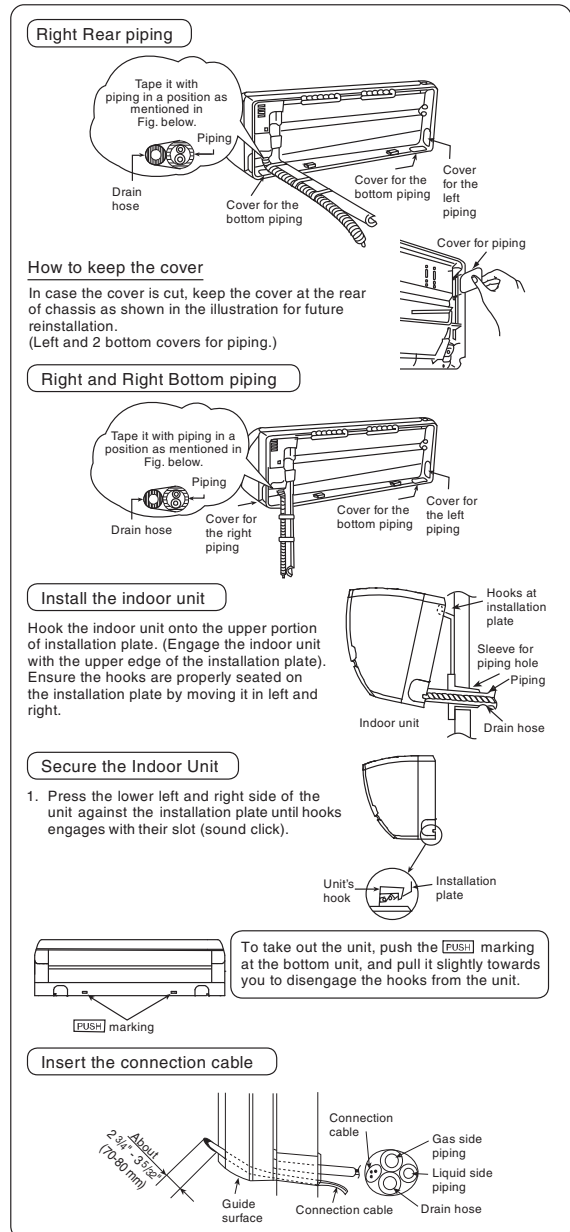

(This can be used for left rear piping and bottom piping also.)

**Replace the drain hose**

Rear view for left piping installation

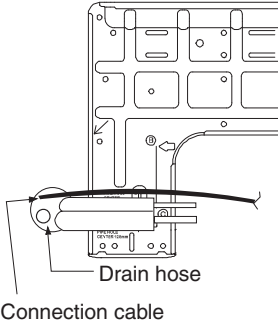
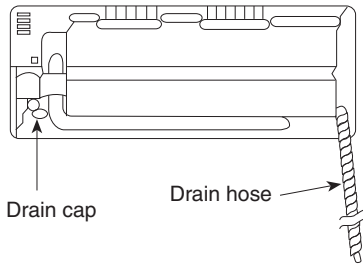

Adjust the piping slightly downwards.

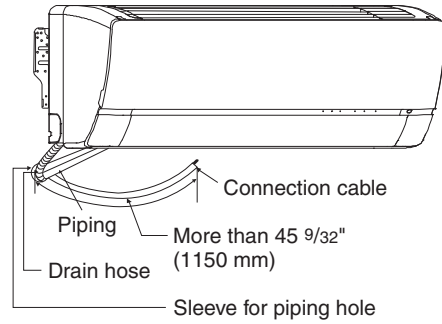

- How to pull the piping and drain hose out, in case of embedded piping.

Apply putty or caulking material to seal the wall opening.

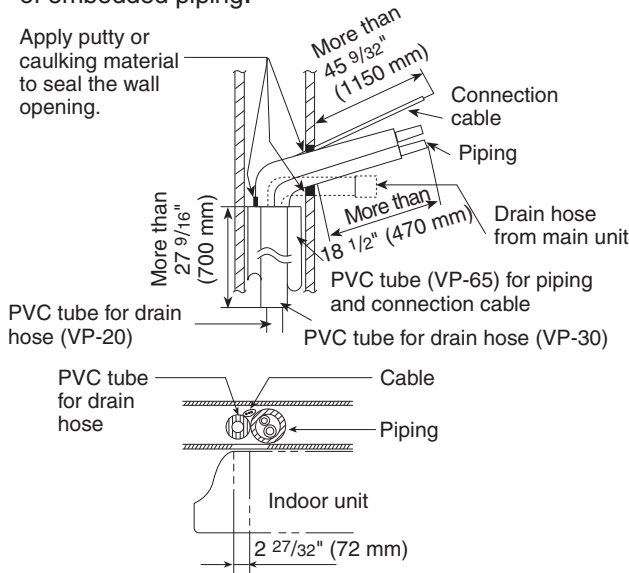

- How to insert the connection cable and drain hose in the case of left piping.

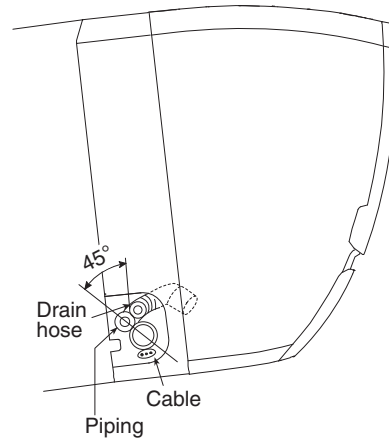

(For right piping, follow the same procedure)

**Drain hose adapter [7] usage**





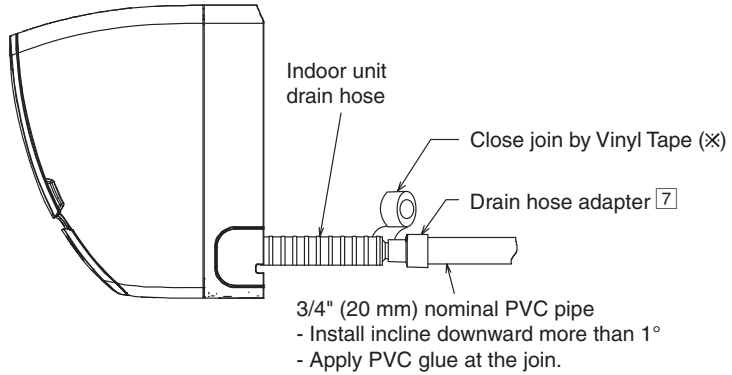

- Join indoor drain hose to 3/4" (20 mm) nominal PVC pipe size by using drain hose adapter [7] when necessary.

Remarks :  
Make sure indoor unit drain hose & 3/4" (20 mm) nominal PVC pipe are fully inserted to drain hose adapter [7].



### 11.2.3 Connect the Cable to the Indoor Unit

- 1 The inside and outside connection cable can be connected without removing the front grille.
- 2 Unscrew the conduit cover and fix the conduit connector to conduit cover with lock nut, then secure it against chassis.
- 3 Connection cable between indoor unit and outdoor unit should be UL listed or CSA approved 4 conductor wires minimum AWG16 in accordance with local electric codes.
  - o Ensure the colour of wires of outdoor unit and terminal number are the same as the indoor's respectively.

Terminals on the indoor unit	1	2	3	
Colour of wires (connection cable)				
Terminals on the outdoor unit	1	2	3	

**⚠ WARNING**

**⚡ This equipment must be properly earthed.**

- o Earth lead wire shall be Yellow/Green (Y/G) in colour and shall be longer than other lead wires as shown in the figure for electrical safety in case of slipping.

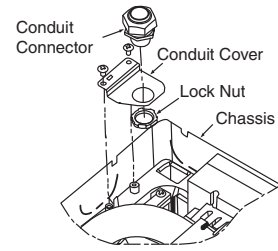

Rear Side of Indoor Unit

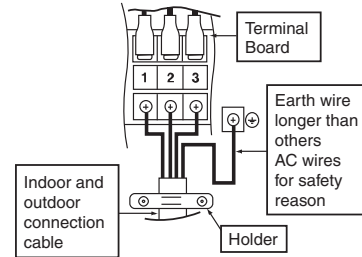

#### 11.2.3.1 Wire Stripping and Connecting Requirement

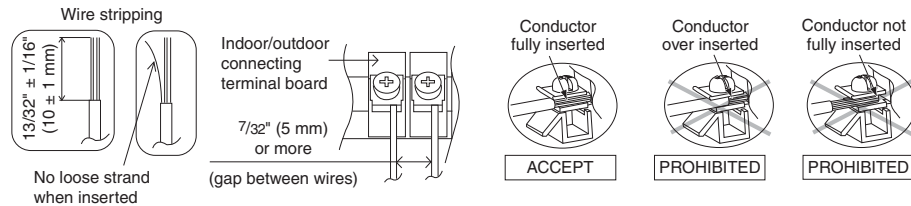

## 11.3 Outdoor Unit

### 11.3.1 Install the Outdoor Unit

- After selecting the best location, start installation according to Indoor/Outdoor Unit Installation Diagram.
  - Fix the unit on concrete or rigid frame firmly and horizontally with a bolt nut  $\varnothing 13/32"$  ( $\varnothing 10$  mm).
  - When installing at roof, please consider strong wind and earthquake.  
Please fasten the installation stand firmly with bolt or nails.

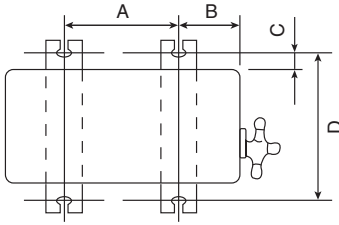

Model	A	B	C	D
XE15SKUA	24-1/8" (613 mm)	5-5/32" (131 mm)	5/8" (16 mm)	14-3/16" (360.5 mm)

### 11.3.2 Connect the Piping

#### 11.3.2.1 Connecting the Piping to Indoor

Please make flare after inserting flare nut (locate at joint portion of tube assembly) onto the copper pipe. (In case of using long piping)

Connect the piping

- Align the center of piping and sufficiently tighten the flare nut with fingers.
- Further tighten the flare nut with torque wrench in specified torque as stated in the table.

#### 11.3.2.2 Connecting the Piping to Outdoor

Decide piping length and then cut by using pipe cutter. Remove burrs from cut edge.

Make flare after inserting the flare nut (located at valve) onto the copper pipe.

Align center of piping to valve and then tighten with torque wrench to the specified torque as stated in the table.

#### 11.3.2.3 Gas leak checking

Pressure test to system to 400 PSIG with dry nitrogen, in stages. Thoroughly leak check the system. If the pressure holds, release the nitrogen and proceed to section 11.3.3.

Do not over tighten, over tightening may cause gas leakage

Piping size	Torque
1/4" (6.35 mm)	13.3 lbf.ft [18N•m (1.8 kgf.m)]
3/8" (9.52 mm)	31.0 lbf.ft [42 N•m (4.3 kgf.m)]
1/2" (12.7 mm)	40.6 lbf.ft [55 N•m (5.6 kgf.m)]
5/8" (15.88 mm)	47.9 lbf.ft [65 N•m (6.6 kgf.m)]
3/4" (19.05 mm)	73.8 lbf.ft [100 N•m (10.2 kgf.m)]

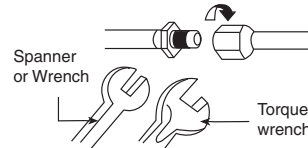

### 11.3.3 Evacuation of the Equipment

WHEN INSTALLING AN AIR CONDITIONER, BE SURE TO EVACUATE THE AIR INSIDE THE INDOOR UNIT AND PIPES in the following procedure.

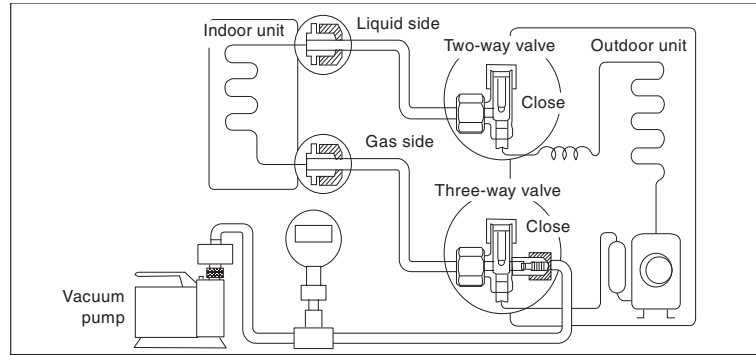

- 1 Connect a charging hose with a push pin to the Low side of a charging set and the service port of the 3-way valve.
- 2 Connect the micron gauge between vacuum pump and service port of outdoor units.
- 3 Turn on the power switch of the vacuum pump and make sure that connect digital micron gauge and to pull down to a value of 500 microns.
- 4 To make sure micron gauge a value 500 microns and close the low side valve of the charging set and turn off the vacuum pump.
- 5 Disconnect the vacuum pump hose from the service port of the 3-way valve.
- 6 Tighten the service port caps of the 3-way valve at a torque of 13.3 lbf•ft (18 N•m) with a torque wrench.
- 7 Remove the valve caps of both of the 2-way valve and 3-way valve. Position both of the valves to “Open” using a hexagonal wrench (5/32” (4 mm)).
- 8 Mount valve caps onto the 2-way valve and the 3-way valve.
  - o Be sure to check for gas leakage.

- If micron gauge value does not descend 500 microns, take the following measures:
  - If the leak stops when the piping connections are tightened further, continue working from step ③.
  - If the leak does not stop when the connections are retightened, repair location of leak.
  - Do not release refrigerant during piping work for installation and reinstallation.
  - Be careful with the liquid refrigerant, it may cause frostbite.

### 11.3.4 Connect the Cable to the Outdoor Unit

- 1 Remove control board cover (Resin and Metal).
- 2 Remove particular plate.
- 3 Remove plugs.
- 4 Fix the conduit connectors to the knockout holes with lock-nuts, then secure them against the side panel.
- 5 All wires pass through conduits & particular plate's opening hole.
- 6 Connecting wire between indoor unit and outdoor unit should be UL listed or CSA approved 4 conductor wires minimum AWG16 in accordance with local electric codes.
- 7 Wire connection to the power supply (208/230V 60Hz) through circuit breaker.
  - o Connect the UL listed or CSA approved wires minimum AWG14 to the terminal board, and connect the other end of the wires to ELCB/GFCI.
- 8 Connect the power supply cord and connecting wire between indoor unit and outdoor unit according to the diagram below.

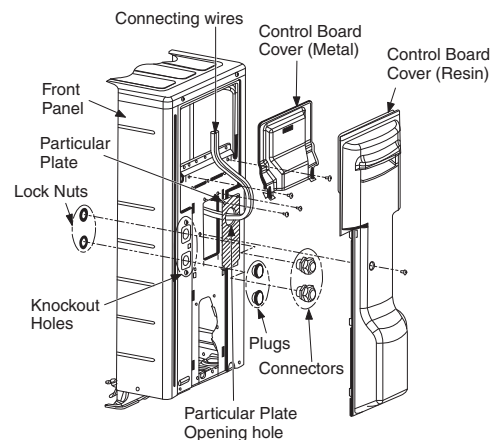



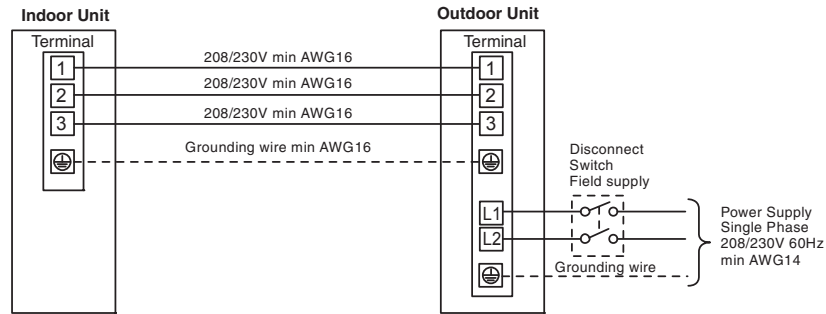

- 9 Secure the wire onto the control board with the holder (clammer).
- 10 After completing wiring connections, reattach the particular plate and control board cover (metal and resin) to the original position with the screws.
- 11 For wire stripping and connection requirement, refer to instruction 11.2.3.1 of indoor unit.

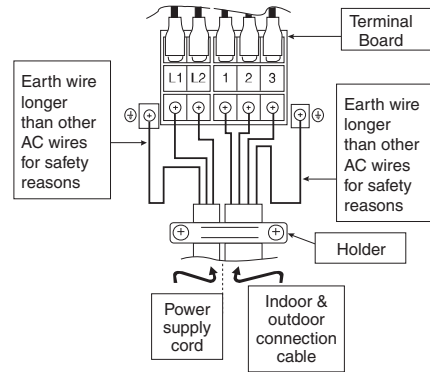

- Earth lead wire shall be Yellow/Green (Y/G) in colour and should be longer than other lead wires as shown in the figure for electrical safety in case of slipping.

### 11.3.5 Piping Insulation

- 1 Please carry out insulation at pipe connection portion as mentioned in Indoor/Outdoor Unit Installation Diagram. Please wrap the insulated piping end to prevent water from going inside the piping.
- 2 If drain hose or connecting piping is in the room (where dew may form), please increase the insulation by using POLY-E FOAM with thickness 1/4" (6 mm) or above.

#### 11.3.5.1 Cutting and flaring the piping

- 1 Please cut using pipe cutter and then remove the burrs.
- 2 Remove the burrs by using reamer. If burrs are not removed, gas leakage may be caused. Turn the piping end down to avoid the metal powder entering the pipe.
- 3 Please make flare after inserting the flare nut onto the copper pipes.

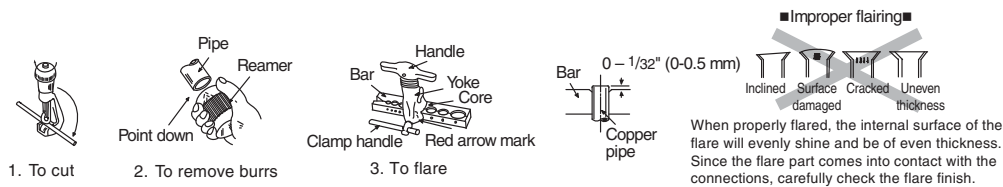

### 11.3.6 Disposal of Outdoor Unit Drain Water

The unit should be mounted on a stand that suits to a local environmental requirement.

- When the Drain elbow being used, please ensure to:-
  - Provide a minimum clearance of 2" (50mm) to access the bottom of base pan.
  - Seal the four 25/32" (20mm) diameter holes with Rubber caps (refer to illustration below).
  - Use a rigid or flexible PVC pipe (local supply) to dispose drained water from the elbow or use a stainless steel tray (local supplied) to collect and dispose water.

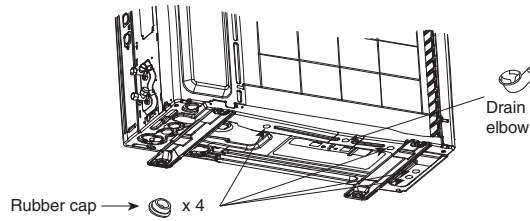

- If the unit is used in an area where temperature falls below 32°F (0°C) for 2 or 3 consecutive days, it is recommended not to use the Drain elbow and Rubber caps, water from defrost process will trap, freeze up and obstruct fan rotation. Water may drip from the basepan hole area during defrost function, do not stand or place objects underneath.