

NORTEK GLOBAL HVAC, LLC

CLICK ANYWHERE on THIS PAGE to RETURN to NORDYNE & NORTEK GLOBAL HVAC AGE & MANUALS at InspectApedia.com

Owner's Manual Installation Instructions

Split System Heat Pumps



16 SEER Outdoor Unit 9K, 12K, 18K, & 24K BTU

- Please read this owner's manual carefully before operation and retain for future reference.
- Specifications & illustrations subject to change without notice or incurring obligations.

GXH09(2.6)LSK4DL
GXH09(2.6)LSA4DL
GHH09(2.6)LSA4DL
GHH09(2.6)LSK4DL
GXH12(3.5)LSK4DL
GXH12(3.5)LSA4DL
GHH12(3.5)LSK4DL
GHH12(3.5)LSA4DL
GXH18(5.3)LSK4DL
GHH18(5.3)LSK4DL
GXH24(7.0)LSK4DL
GHH24(7.0)LSK4DL

Contents

Operation Notices

Precautions.	1
Parts Name.	6

Screen Operation Guide

Remote Control Buttons.	8
Display Screen Icons	8
Remote Control Button Description	9
Combination Button Functions	13
Operation Guide	14
Replacing Batteries in Remote.	15
Emergency Operation.	15

Maintenance

Cleaning and Maintenance.	16
-----------------------------------	----

Troubleshooting

Troubleshooting	18
---------------------------	----

Installation

Installation Clearances.	21
Tools for Installation	22
Installation Location Selection	22
Electrical Requirements	23
Indoor Unit Installation	24
Outdoor Unit Installation.	29
Vacuum Pumping	32
Leak Detection	32
After Installation Checklist	33

Testing and Operation

Test Operation	34
--------------------------	----

Connections





Connection Pipe Configuration.	34
Pipe Expansion Method	36

Wired Controller

Optional Wired Controller.	37
------------------------------------	----

This appliance is not intended for use by persons (including children) with reduced physical, sensory or mental capabilities, or lack of experience and knowledge. Children should not play with the appliance.

Explanation of Symbols

-  **DANGER** Failure to comply will result in severe personal injury, property damage and/or death.
-  **WARNING** Failure to comply may result in severe personal injury, property damage and/or death.
-  **CAUTION** Failure to comply may result in personal injury and/or property damage.
-  **NOTICE** Indicates important but not hazard-related information, used to indicate risk of property damage.



Operation and Maintenance

- This appliance should not be used by children or persons with reduced physical, sensory or mental capabilities or lack of experience and knowledge.
- Children shall not play with the appliance.
- Cleaning and user maintenance shall not be performed by children.
- Do not connect heat pump to multi-purpose socket. Otherwise, it may cause fire hazard.
- Disconnect power supply when cleaning heat pump. Otherwise, it may cause electric shock.
- If the supply cord is damaged, it must be replaced by qualified persons.
- Do not wash the heat pump with water to avoid electric shock.
- Do not spray water on indoor unit. It may cause electric shock or malfunction.
- After removing the filter, do not touch fins to avoid injury.
- Do not dry filter over open flame or with hair dryer to avoid warping fire hazard.
- Maintenance must be performed by qualified professionals. Otherwise, it may cause personal injury or damage.
- Do not repair heat pump by yourself. It may cause electric shock or damage. Please contact dealer when you need to repair heat pump.

Precautions



WARNING

- Do not insert fingers or objects into air inlet or air outlet. It may cause personal injury or damage.
- Do not block air outlet or air inlet. It may cause malfunction.
- Do not spill water on the remote controller.
- When below situations occur, please turn off heat pump and disconnect power immediately, and then contact the dealer or qualified professionals for service.
 - Power cord is overheating or damaged.
 - There's abnormal sound during operation.
 - Circuit breaker trips off frequently.
 - Heat pump gives off burning smell.
 - Indoor unit is leaking.
- If the heat pump malfunctions, it may cause electric shock or fire.
- When turning on or turning off the unit by emergency operation switch, please press this switch with an insulating object other than metal.
- Do not place objects on outdoor unit or use as step. It may cause damage or personal injury

Precautions



WARNING

Attachment

- Installation must be performed by qualified professionals. Otherwise, it may cause personal injury or damage.
- Follow all the electric safety regulations when installing the unit.
- Use approved power supply circuit and circuit breaker according to local regulations.
- A circuit breaker must be used.
- An all-pole disconnect switch having a contact separation of at least 3mm (1/8 in) in all poles should be connected in fixed wiring.
- Include a circuit break with suitable capacity, please note the capacity table. Air switch should include magnet buckle and heating buckle function, to protect from circuit-short and overload.
- Heat pump should be properly grounded. Incorrect grounding may cause electric shock.
- Use only an approved power cord.
- Make sure the power supply matches the requirement listed on nameplate. Unstable power supply or incorrect wiring may cause malfunction. Please install proper power supply cables before using the heat pump.
- Properly connect the live wire, neutral wire and grounding wire.
- Be sure to cut off the power supply before performing any work related to electricity.

Precautions



WARNING

- Do not connect power before finishing installation.
- If the supply cord is damaged, it must be replaced by qualified persons.
- The temperature of refrigerant circuit will be high, please keep all cords and cables away from the copper tube.
- The appliance shall be installed in accordance with national wiring regulations.
- Installation must be performed in accordance with the requirement of NEC and CEC by authorized personnel only.
- The heat pump is Class I electric appliance. It must be properly grounded by a professional, otherwise it may cause electric shock.
- The yellow-green wire in heat pump must be used for grounding only.
- The grounding resistance should comply with national electric safety regulations.
- The appliance must be positioned so that the plug is accessible.
- All wires of indoor unit and outdoor unit should be connected by a professional.
- Use single wires for all connections. Wires should never be spliced together.
- For the heat pump with plug, the outlet should be reachable after finishing installation.
- For the heat pump without plug, a circuit break must be installed in the line.

Precautions



WARNING

- Once installed the heat pump should not be moved and installed in a different location.
- Select a location which is out of reach for children and far away from animals or plants. If it is unavoidable, please put up a fence for safety purpose.
- The indoor unit should be installed close to the wall

Working Temperature Range

	Indoor Temp. DB/WB °C(°F)	Outdoor Temp. DB/WB °C(°F)
Maximum cooling	26.7/19.4(80/66.9)	46.1/23.9(115/75)
Maximum heating	26.7/-(80/-)	23.9/18.3(75/64.9)

NOTICE:

- The operating temperature range (outdoor temperature) for cooling only unit is $-18^{\circ}\text{C}(-0.4^{\circ}\text{F}) \sim 46.1^{\circ}\text{C}(115^{\circ}\text{F})$; for heat pump unit is $-20^{\circ}\text{C}(-4^{\circ}\text{F}) \sim 46.1^{\circ}\text{C}(115^{\circ}\text{F})$.

Parts Name

Indoor Unit

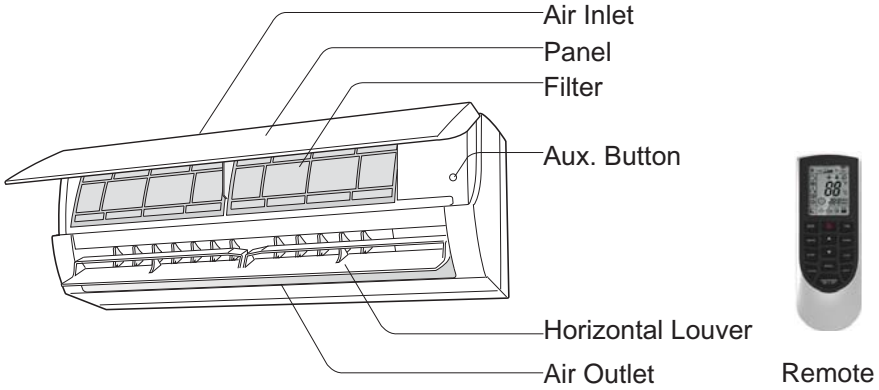

Outdoor Unit

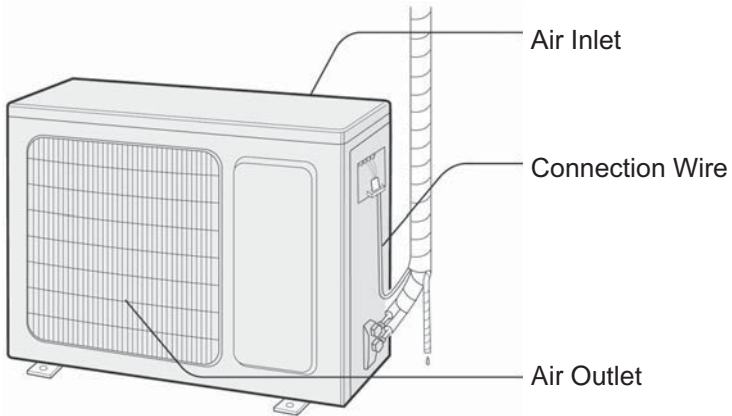

NOTICE:

Illustrations provided apply to different models and are for reference only. Actual equipment may look slightly different.

Parts Name

Display

Following are examples of displays found on different models. These illustrations are for reference only. Actual displays may look slightly different.

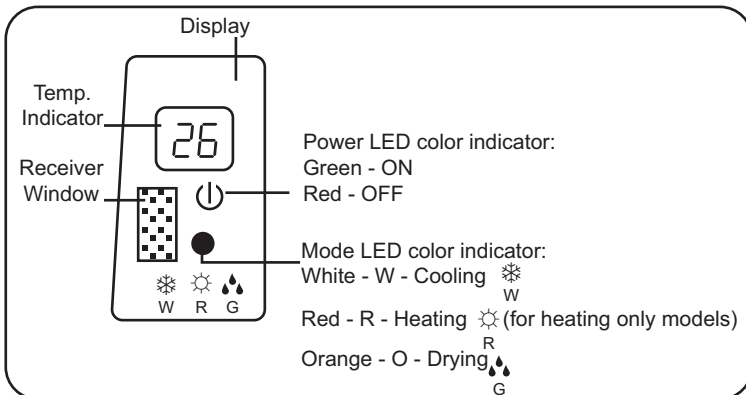
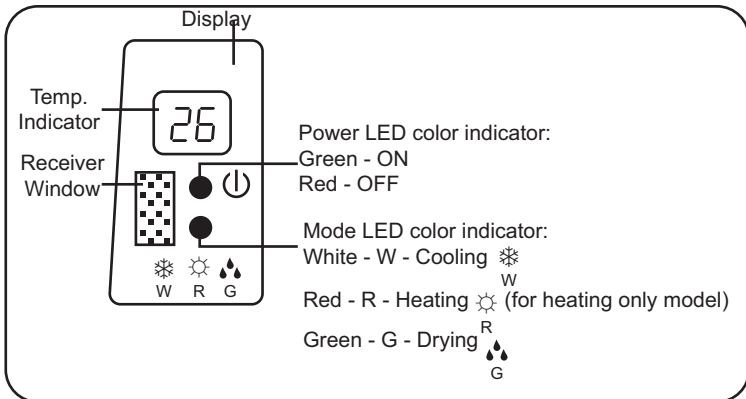
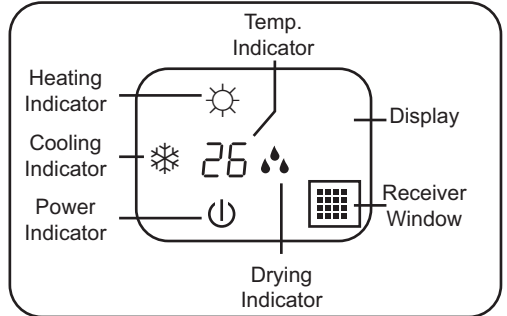
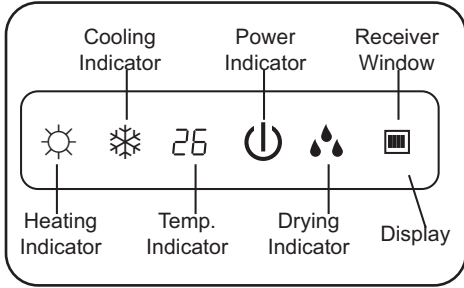

Remote Control Buttons



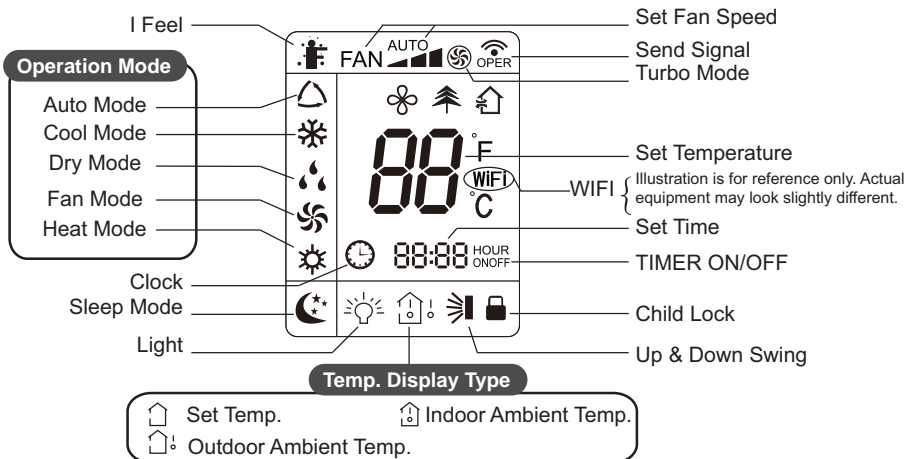

1. ON/OFF Button
2. MODE Button
3. FAN Button
4. SWING Button
5. TURBO Button
6. ▲ / ▼ Button
7. SLEEP Button
8. TEMP Button
9. I FEEL Button
10. LIGHT Button
11. CLOCK Button
12. TIMER ON/TIMER OFF Button

Display Screen Icons



Remote Control Button Description

Note:

- This remote can control different heat pump models. Some models may not have all functions shown on remote. Pressing the buttons for these functions will have no effect on the heat pump.
- After turning on the power, the heat pump will emit a sound. Power indicator  will be ON (red indicator). After that, you can operate the heat pump by using remote controller.
- Under on status, pressing a button on the remote controller, the signal icon  on the display of remote controller will blink once and the heat pump will give out a “de” sound, which means the signal has been sent to the heat pump.
- Under off status, set temperature and clock icon will be displayed on remote controller (If timer on, timer off and light functions are set, the corresponding icons will be displayed on remote controller at the same time); Under on status, the display will show the corresponding set function icons.





1 ON/OFF Button

Press this button to turn on or turn off the heat pump. After turning on the heat pump, operation indicator  on indoor unit's display is ON and indoor unit will give out a sound.

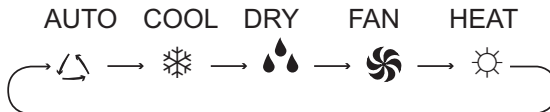
2 MODE Button

Press this button to select your required operation mode.



- When selecting auto mode, heat pump will operate automatically according to default setting. Set temperature can't be adjusted and will not be displayed. Press “FAN” button to adjust fan speed. Press “SWING” button to adjust louver angle.
- After selecting cool mode, heat pump will operate under cool mode. Cool indicator  on indoor unit is ON. Press  or  button to adjust set temperature. Press “FAN” button to adjust fan speed. Press “SWING” button to adjust louver angle.
- When selecting dry mode, the heat pump operates at low speed under dry mode. Dry indicator  on indoor unit is ON. Under dry mode, fan speed can't be adjusted. Press “SWING” button to adjust louver angle.
- When selecting fan mode, only the fan will operate, no cooling and no heating. All indicators are OFF. Press “FAN” button to adjust fan speed. Press “SWING” button to adjust louver angle.

Remote Control Button Description

- When selecting heating mode, the heat pump operates under heat mode. Heat indicator ☀ on indoor unit is ON. Press ▲ or ▼ button to adjust set temperature. Press “FAN” button to adjust fan speed. Press “SWING” button to adjust louver angle. (Cooling only unit won't react to heating mode signal.

Note:

- For preventing cold air, after starting up heating mode, indoor unit will delay 1~5 minutes to blow air (actual delay time is depend on indoor ambient temperature).
- Set temperature range from remote controller: 16~30°C(61~86°F); Fan speed: auto, low speed, medium speed, high speed.

3 FAN Button

Press this button to set fan speed: auto (AUTO), low(▲), medium (▲▲), high(▲▲▲).

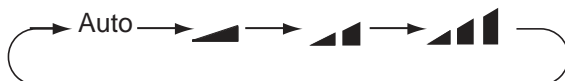

Note:

- Under AUTO speed, heat pump will select proper fan speed automatically according to default setting.
- Fan speed under dry mode is low speed.

4 SWING Button

Press this button to select up&down swing angle. Louver angle can be selected as shown below:

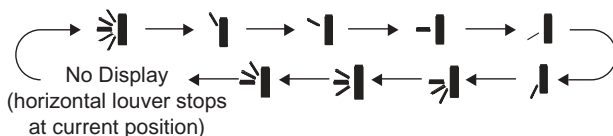



- When selecting ▲, heat pump is blowing fan automatically. Horizontal louver will automatically swing up&down at maximum angle.
- When selecting ▼, ▲, -|, ▲, ▼ horizontal louvers will stop at fixed position.
- When selecting ▲, ▼, ▲ horizontal louver will swing through fixed angles.
- Hold ▲ button more than 2s to set your required swing angle. When reaching your required angle, release the button.

Note:

- ▲, ▼, ▲ may not be available. When heat pump receives this signal, the heat pump will default to automatic setting.

Remote Control Button Description

5 TURBO Button



Under COOL or HEAT mode, press this button to select quick COOL or HEAT mode.  icon will display on remote controller. Press this button again to exit turbo function and  icon will disappear.

6 ▲ / ▼ Button

- Press ▲ or ▼ button once increase or decrease set temperature 1 degree (C or F) Holding ▲ or ▼ button, more than 2 seconds, the set temperature on remote controller will change quickly. On releasing button after setting is finished, temperature indicator on indoor unit will change accordingly. (Temperature can't be adjusted under auto mode)
- To set TIMER ON, TIMER OFF or CLOCK, press ▲ or ▼ button to adjust time. (Refer to CLOCK, TIMER ON, TIMER OFF buttons)

7 SLEEP Button



Under COOL, HEAT or DRY mode, press this button to start up sleep function.

 icon is displayed on remote controller. Press this button again to cancel sleep function and  icon will disappear.

8 TEMP Button

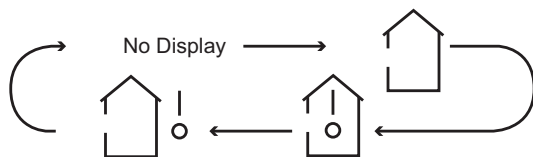
By pressing this button, you can see indoor set temperature, indoor ambient temperature or outdoor ambient temperature on indoor unit's display. As shown below:



- When selecting  or no display with remote controller, temperature indicator on indoor unit displays set temperature.
- When selecting  with remote controller, temperature indicator on indoor unit displays indoor ambient temperature.
- When selecting  with remote controller, temperature indicator on indoor unit displays outdoor ambient temperature.



Note:

- Outdoor temperature display is not available for some models. These models will display the indoor set temperature when outdoor temperature is selected.



Remote Control Button Description

- The default setting is the set temperature. The temperature will only be displayed after a set temperature is set up.
- Until set temperature is set up, remote will display “88”
- When selecting indoor or outdoor ambient temperature, indoor temperature indicator displays current temperature and automatically returns to display set temperature after three to five seconds.









9 I FEEL Button

- Press this button to start I FEEL function and  will be displayed on the remote controller. After this function is set, the remote controller will send the detected ambient temperature to the controller and the unit will automatically adjust the indoor temperature according to the detected temperature. Press this button again to close I FEEL function and  will disappear.
- Please put the remote controller near the user when this function is set. Do not put the remote controller near other heat source or cooling equipment to avoid detecting inaccurate ambient temperature.

10 LIGHT Button

Press this button to turn off display light on indoor unit.  icon on remote controller disappears. Press this button again to turn on display light.  icon is displayed.







11 Clock Button

- Press this button to set clock time.  icon on remote controller will blink. Press  or  button within 5s to set clock time. Press the of  or  button, once to increase or decrease 1 minute. Hold the  or  button, more than 2 seconds to change time more quickly. Release this button when reaching your required time. Press “CLOCK” button to confirm the time,  icon stops blinking.

Note:

- Clock time defaults to 24-hour mode.
- If no button is pressed for 5 seconds, remote controller will quit setting status. Operation for TIMER ON/TIMER OFF is the same.

12 TIMER ON / TIMER OFF button

- TIMER ON button
“TIMER ON” button can set the time for unit to be turned on. After pressing this button,  icon disappears and the word “ON” on remote controller blinks. Press  or  button to adjust TIMER ON setting. Press the  or  button, once to increase or decrease TIMER ON setting by 1 min. Hold  or  button, for more than 2 seconds to change the time more quickly. Release the button when you

Remote Control Button Description

reached desired time. Press “TIMER ON” to confirm. The word “ON” will stop blinking. ⌚ icon resumes displaying. Cancel TIMER ON: After setting TIMER ON, press the TIMER ON button again to cancel the setting.

- **TIMER OFF button**

“TIMER OFF” button can set the time for unit to be turned off. After pressing this button, icon disappears and the word “OFF” on remote controller blinks. Press ▲ or ▼ button to adjust TIMER OFF setting. Press the ▲ or ▼ button, once to increase or decrease TIMER OFF setting by 1 min. Hold ▲ or ▼ button, for more than 2 seconds to change the time more quickly. Release the button when you reached desired time.

Press “TIMER OFF” to confirm. “OFF” will stop blinking. ⌚ icon resumes displaying. After setting TIMER OFF, press the TIMER PFF button again to cancel the setting.

Note:

- Under on and off status, you can set TIMER OFF or TIMER ON .
- Before setting TIMER ON or TIMER OFF, make sure clock displays current time.
- When TIMER ON or TIMER OFF are set, the ON/OFF button will not work. TIMER ON or TIMER OFF will need to be cancelled as explained above.

Combination Button Functions

Energy-Saving Function



Under cooling mode, press “TEMP” and “CLOCK” buttons simultaneously to start up or turn off energy-saving function. When energy-saving function is started up, “SE” will be shown on remote controller, and heat pump will adjust the set temperature automatically according to default setting to reach to the best energy-saving effect. Press “TEMP” and “CLOCK” buttons simultaneously again to exit energy-saving function.

Note:

- Under energy-saving function, fan speed is defaulted at auto speed and it can't be adjusted.
- Under energy-saving function, set temperature can't be adjusted.
- Sleep function and energy-saving function can't operate at the same time. If energy-saving function has been set under cooling mode, press sleep button will cancel energy-saving function. If sleep function has been set under cooling mode, start up the energy-saving function will cancel sleep function.

Combination Button Functions

Child Lock Function

Press ▲ and ▼ buttons simultaneously to turn on or turn off child lock function. When child lock function is on,  icon is displayed on remote controller. If you press any button on the remote controller, the  icon will blink three times without sending signal to the unit.

Temperature Scale Display Function

Under OFF status, press ▼ and “MODE” buttons simultaneously to switch temperature display between °C and °F.

Operation Guide

1. After turning on the power, press “ON/OFF” button on remote controller to turn on the heat pump.
2. Press “MODE” button to select your required mode: AUTO, COOL, DRY, FAN, HEAT.
3. Press ▲ or ▼ button to set your required temperature. (Temperature can't be adjusted under auto mode).
4. Press “FAN” button to set your required fan speed: auto, low, medium and high speed.
5. Press “SWING” button to select fan blowing angle.

Replacing Batteries in Remote

1. Press the back side of remote controller marked "OPEN," and push the battery cover as shown in the figure to the right.
2. Replace two 7# (AAA 1.5V) dry batteries, and make sure the position of "+" and "-" polar poles are aligned correctly.
3. Reinstall the battery cover.

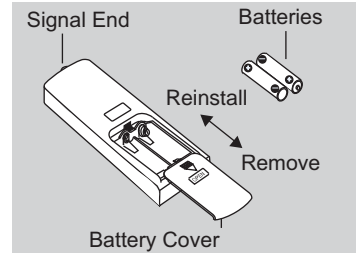

Notice

- During operation, point the remote control signal sender at the receiving window on indoor unit.
- The distance between signal sender and receiving window should be no more than 8m (25 ft), and there should be no obstacles in the path.
- Florescent lamp, wireless telephone or other devices may interfere with the remote signal. If this is the case, move the remote closer to the heat pump.
- When replacing batteries use the same type of new batteries.
- When you don't use remote controller for a long time, please take out the batteries.
- If the display on remote controller is fuzzy or there's no display, please replace batteries.

Emergency Operation

If remote controller is lost or damaged, please use the auxiliary button for ON/OFF control. Open the panel, press the auxiliary button to turn on or off the heat pump. When turned on, it will operate under AUTO mode.

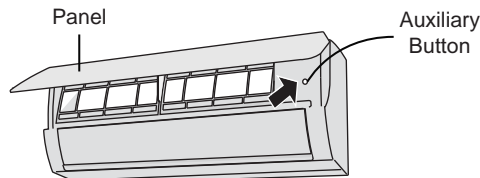

⚠ WARNING

Use insulated object to press the auxiliary button.

Cleaning and Maintenance

WARNING

- Turn off the heat pump and disconnect the power before cleaning to avoid electric shock.
- Do not wash the heat pump with water to avoid electric shock.
- Do not use volatile liquid to clean the heat pump.

Cleaning the Surface of Indoor Unit

When the surface of indoor unit is dirty, it is recommended to use a soft dry cloth or damp cloth to wipe it.

NOTICE:

- Do not remove the panel when cleaning it.

Clean Filter

1. Open Panel
Pull out the panel and raise it up as shown below.

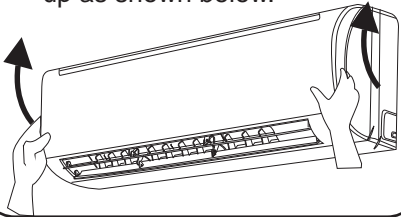

2. Remove Filter
Remove the filter as shown below

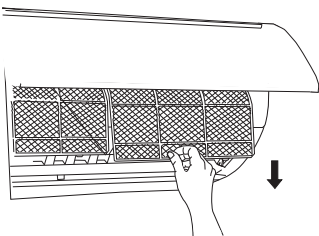

3. Clean Filter
Use dust catcher to clean the filter.
If the filter is very dirty, use water.
Note: water can not be warmer than 45°C (113°F). Let filter sit in cool dry place until dry.

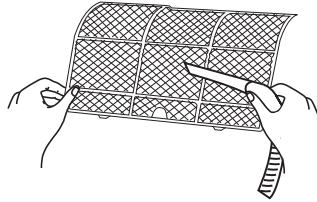

4. Reinstall Filter
Install the filter, and close the panel cover tightly.

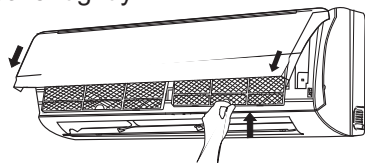

Cleaning and Maintenance

WARNING

- The filter should be cleaned every three months. If heat pump is exposed to very dusty conditions, please clean the filter more frequently.
- After removing the filter, do not touch fins to avoid personal injury and damage to the unit.
- Never dry filter over open flame or with hair dryer to avoid warping or fire.

Notice: Preseason Checklist

1. Check whether air inlets and air outlets are blocked.
2. Check whether circuit break, plug and socket are in good condition.
3. Check to make sure filter is clean.
4. Check if mounting bracket of outdoor unit is damaged or corroded. If it is, please contact your dealer or qualified service technician.
5. Check if drainage pipe is damaged.

Notice: Post-Season Checklist

1. Disconnect power supply.
2. Clean filter and indoor unit panel.
3. Check if mounting bracket of outdoor unit is damaged or corroded. If it is, please contact your dealer or qualified service technician.

Disposal and Recycling

1. Many packing materials are recyclable. Please dispose or recycle responsibly.
2. Contact local dealer or service center for the proper disposal method.

Troubleshooting

General Analysis

Please check below items before asking for maintenance. If the malfunction persists, please contact a local dealer or other qualified professional.

Malfunction	Check Items	Solutions
Wireless controller won't work	<ul style="list-style-type: none"> The heat pump may be receiving false signals from other electromagnetic sources. Or, too many signals have been sent too rapidly from the wireless controller 	<ul style="list-style-type: none"> Unplug the heat pump. Wait 3 minutes and plug it in again. Turn unit back on.
	<ul style="list-style-type: none"> Is the remote controller within the signal receiving range? 	<ul style="list-style-type: none"> Signal receiving range is 8M (25 ft).
	<ul style="list-style-type: none"> Are there obstacles between remote and heat pump? 	<ul style="list-style-type: none"> Remove obstacles.
	<ul style="list-style-type: none"> Is remote controller pointing at the receiving window? 	<ul style="list-style-type: none"> Select proper angle and point the remote controller at the receiving window on indoor unit.
	<ul style="list-style-type: none"> Is sensitivity of remote controller low; fuzzy display or no display? 	<ul style="list-style-type: none"> Check the batteries. Replace them if needed.
	<ul style="list-style-type: none"> No display when operating remote controller? 	<ul style="list-style-type: none"> Check whether remote controller appears to be damaged. If yes, replace it.
	<ul style="list-style-type: none"> Fluorescent lamp in room? 	<ul style="list-style-type: none"> Move the remote controller closer to indoor unit. Turn off the fluorescent lamp and then try it again.
The indoor unit is on, but will not run	<ul style="list-style-type: none"> Is the air inlet or outlet of the indoor unit blocked? 	<ul style="list-style-type: none"> Eliminate obstacles.
	<ul style="list-style-type: none"> Under heating mode, indoor temperature is reached to set temperature? 	<ul style="list-style-type: none"> After reaching to set temperature, indoor unit will stop.
	<ul style="list-style-type: none"> Was heating mode just turned on? 	<ul style="list-style-type: none"> In order to prevent blowing out cold air, indoor unit waits until heating element has warmed up.

Troubleshooting

Malfunction	Check Items	Solutions
Heat pump won't run	• Power failure?	• Wait until power recovery.
	• Is plug loose?	• Reinsert the plug.
	• Circuit break trips off or fuse is burnt out?	• Ask professional to replace circuit break or fuse.
	• Wiring malfunction?	• Call professional for repair.
	• Unit has restarted immediately after stopping operation?	• Wait for 3 min, and then turn on the unit again.
	• Is the function setting for remote controller is correct?	• Reset the function.
Mist emitted from indoor unit air outlet	• Is indoor temperature and humidity high?	• Mist is formed when indoor air is humid and cooled rapidly. After heat pump runs a while, indoor temperature and humidity will decrease and mist will disappear.
Set temperature can't be adjusted	• Is unit operating under auto mode?	• Temperature can't be adjusted under auto mode. Switch the operation mode if you need to adjust temperature.
	• Does the desired temperature exceeds the set temperature range?	• Set temperature range: 16~30°C (61~86°F).
Poor cooling (heating performance)	• Is the supply voltage too low?	• If temporary occurrence, wait until voltage returns to normal. • Contact a qualified electrician.
	• Is the filter dirty?	• Clean filter.
	• Is the set temperature in allowable range?	• Adjust temperature to proper range.
	• Are doors or windows open?	• Close door or window.
Odor emitted	• Is there an odor source in the room such as cigarettes?	• Eliminate source of odor. • Clean filter.
Heat pump operates erratically	• Is there interference, such as thunder, wireless devices, etc	• Turn unit off. Turn off power supply. Reconnect power after a few seconds. Turn unit back on. If problem persists, contact a qualified service technician.

Troubleshooting

Malfunction	Check Items	Solutions
Water flowing noise	<ul style="list-style-type: none"> Has heat pump just been turned on or turned off? 	<ul style="list-style-type: none"> The noise is the sound of the unit, which is normal.
Cracking noise	<ul style="list-style-type: none"> Has heat pump just been turned on or turned off? 	<ul style="list-style-type: none"> This is the sound of friction caused by expansion and/or contraction of panel or other parts due to the change of temperature.

Error Codes

- When heat pump malfunctions, the temperature indicator on indoor unit will blink displaying the corresponding error code. Please refer to the below list for required action to be taken.

Error Code	Troubleshooting
C5	Please contact qualified professional for service.
E5	It can be eliminated after restarting the unit. If not, please contact qualified professional for service.
E8	It can be eliminated after restarting the unit. If not, please contact qualified professional for service.
F1	Please contact qualified professional for service.
F2	Please contact qualified professional for service.
H6	It can be eliminated after restarting the unit. If not, please contact qualified professional for service.
U8	It can be eliminated after restarting the unit. If not, please contact qualified professional for service.

Note: For any other error codes contact qualified professional for service.

WARNING

- When any of the following situations occur, turn off heat pump, disconnect power immediately, and contact a qualified professional for service.
 - Power cord is overheating or damaged.
 - There's abnormal sound during operation.
 - Air switch trips off frequently.
 - Heat pump gives off burning smell.
 - Indoor unit is leaking.
- Do not repair or refit the heat pump by yourself.
- If the heat pump continues to operate while malfunctioning, it may be damaged beyond repair or cause electrical shock or fire.

Installation Clearances

Dimension below show minimum clearances from obstacles, walls, ceiling, floor, etc. allowed around indoor and outdoor units.

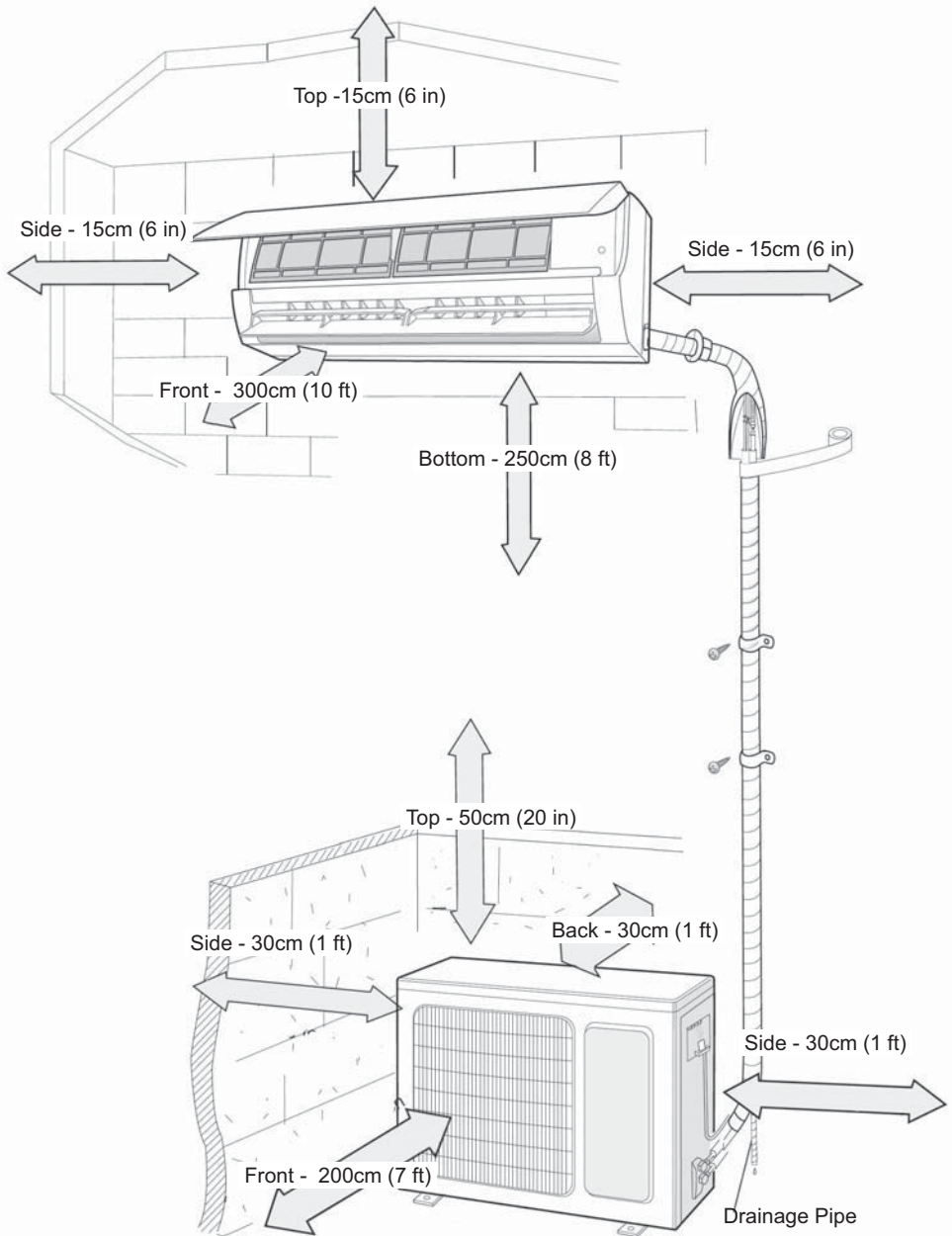

Tools for Installation

- | | | |
|------------------|--------------------|--------------------|
| 1. Level | 6. Torque wrench | 11. Pressure Meter |
| 2. Screwdriver | 7. Open-end wrench | 12. Multi-meter |
| 3. Impact drill | 8. Pipe cutter | 13. Hexagon wrench |
| 4. Drill bit | 9. Leak detector | 14. Measuring tape |
| 5. Pipe expander | 10. Vacuum pump | |

Note:

- Contact qualified professional for installation
- Proper power cord must be used.

Installation Location Selection

Basic requirement:

Installing the unit in the following places may cause malfunction.

1. Places with strong heat sources, vapors, flammable or explosive gasses, or volatile objects spread in the air.
2. Places with high-frequency devices (such as welding machine, medical equipment).
3. Coastal regions.
4. The place with oil other fumes in the air.
5. Places with high sulfur gas concentration in the air.
6. Other places with special circumstances.
7. Do not use the unit in a laundry, bath, shower, or indoor swimming pool.

Indoor Unit

1. There should be no obstruction near air inlet and air outlet.
2. Select a location where the condensation water can be drained easily and won't drip on people, animals, other's property, etc.
3. Select a location which is convenient to connect the outdoor unit and near the power socket.
4. Select a location which is out of reach for children.
5. The support structure should have sufficient load-carrying capacity to support the weight of the unit. The unit should be securely mounted to avoid vibration.
6. The heat pump must be installed 2.5m(8 ft) above the floor.
7. Don't install the indoor unit right above an electric appliance.
8. It's best to keep unit as far as possible from fluorescent lamps.

Outdoor Unit

1. Select a location where the noise and outflow air emitted by the outdoor unit will not disturb neighbor
2. The location should be well ventilated and dry, in which the outdoor unit won't be exposed directly to sunlight or strong wind.
3. The location should be able to withstand the weight of outdoor unit.
4. Make sure that the installation follows the requirement of installation dimension diagram.
5. Select a location which is out of reach for children and far away from animals or plants. If it is unavoidable, please add the fence for safety purpose.

Electrical Requirements

Safety Precautions

1. Follow all electric safety regulations when installing the unit.
2. Use approved power supply, circuit and circuit breaker as required by local regulations.
3. Make sure the power supply matches with the requirement listed on the nameplate. Unstable power supply or incorrect wiring will cause malfunction. Use approved power supply cable.
4. Properly connect the live wire, neutral wire and grounding wire.
5. Turn off the power supply before performing any work related to electricity and safety.
6. Complete all installation requirements before connecting power supply.
7. If the power cord is damaged, it must be replaced by qualified personnel.
8. The refrigerant piping will be hot. Be sure to keep all cables away from copper tubing.
9. The appliance shall be installed in accordance with national wiring regulations.

Grounding Requirement

1. The heat pump is a Class I electric appliance. It must be properly grounded with specialized grounding device by a professional, or it may cause electric shock.
2. The yellow-green wire in heat pump can only be used as the grounding wire.
3. The grounding resistance should comply with national electric safety regulations.
4. The appliance must be positioned so that the plug is accessible.
5. An all-pole disconnection switch having a contact separation of at least 3mm (1/8 in) in all poles should be connected in fixed wiring. For models with a power plug, make sure the outlet is within reach after installation.

Indoor Unit Installation

Step one: choosing installation location

Consult with building owner on installation location, then confirm appropriateness before installing.

Step two: install wall-mounting frame

1. Hang the wall-mounting frame on the wall; make sure it is level. Mark the screw locations on the wall.
2. Drill holes in the wall for screws. Insert plastic expansion or anchor in the hole.
3. Attach the wall-mounting frame on the wall with tapping screws (ST4.2X25TA) and then check if the frame is firmly installed.

Step three: open piping hole

1. Select the location for the outlet pipe and make an opening in the wall. The position of piping hole should be a little lower than the wall-mounted frame, shown as below.

Size 09K

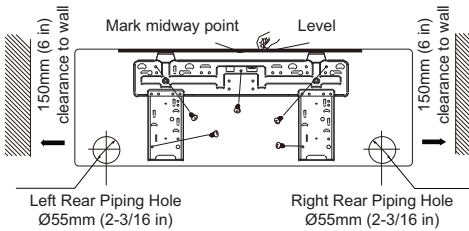

Size 12K

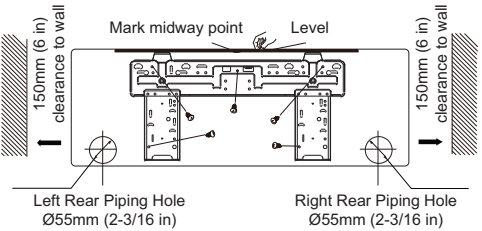

Size 18K

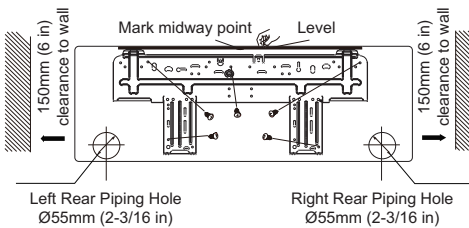

Size 24K

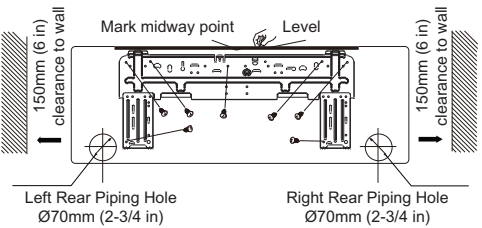

2. Open a piping hole with the diameter of $\Phi 55$ or 70 mm (2-3/16 or 2-3/4 in) at the selected position. In order to drain smoothly, slope the piping hole on the wall slightly downward to the outdoor side with the gradient of 5-10°.

Indoor Unit Installation

Note:

- Take all appropriate safety precautions when making pipe hole. Try to avoid creating as much dust as possible.
- The plastic expansion anchors are not provided and should be provided by installing contractor.

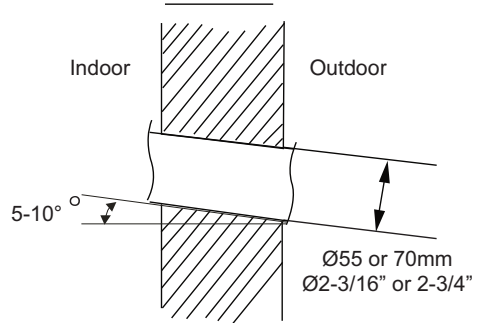

Step four: outlet pipe

1. The pipe can be led out in the right, rear right, left, or rear left of the heat pump.

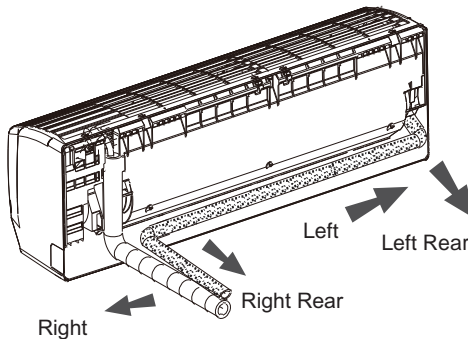

2. After selection position of outlet pipe (left or right), cut off the corresponding hole on bottom of case.

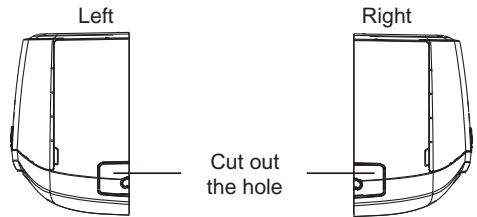

Step five: connect pipe to outdoor unit

1. Align the pipe joint at the corresponding valve.
2. Tighten the union nut by hand.
3. Adjust the torque force by referring to the following sheet. Place the open-end wrench on the pipe joint and place the torque wrench on the union nut. Tighten the union nut with torque wrench.

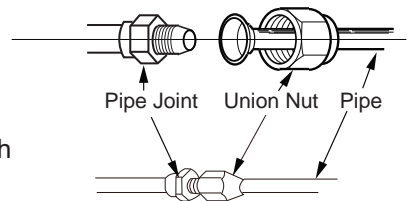

Indoor Unit Installation

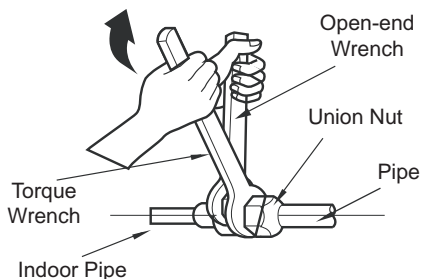

Hex Nut Diameter	Tightening Torque (N-m)
Ø6mm (1/4 in)	15~20
Ø9.52mm (3/8 in)	30~40
Ø 12mm (1/2 in)	45~55
Ø16mm (5/8 in)	60~65
Ø19mm (3/4 in)	70~75

4. Wrap the indoor pipe and joint of connection pipe with insulating pipe, and then wrap it with tape.

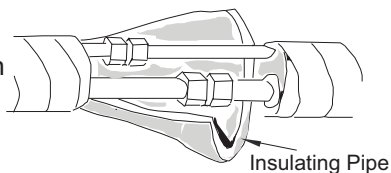

Step six: install drain hose

1. Connect the drain hose to the outlet pipe of indoor unit.
2. Secure the joint with tape.

Note:

- Add insulating pipe in the indoor drain hose in order to prevent condensation.
- The plastic expansion anchors are not provided.

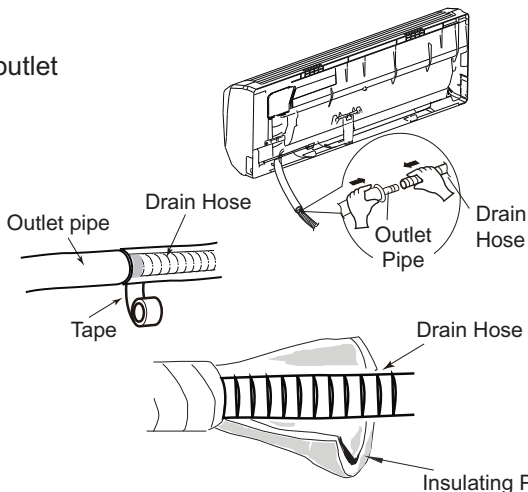

Step seven: connect wire of indoor unit

1. Open the panel, remove the screw on the wiring cover and then take down the cover.

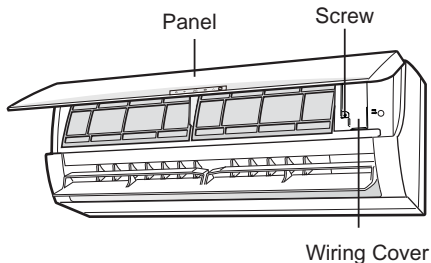

Indoor Unit Installation

2. Lead the power wire through the cable-cross hole at the back of indoor unit and then pull it out from the front side.
3. Remove the wire clip; connect the power connection wire to the wiring terminal according to the color. Tighten the screw and secure the power cable with the wire clip.

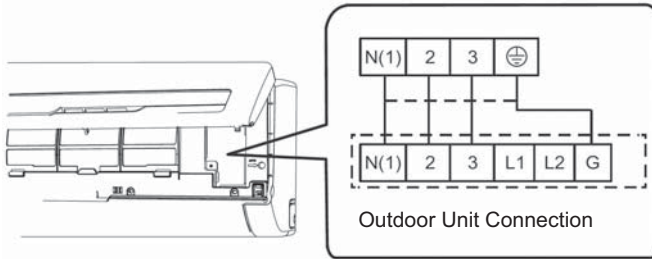
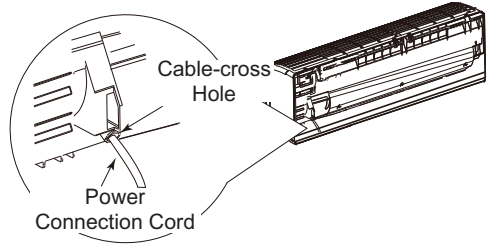

4. Replace wiring cover and tighten the screw.
5. Close the panel.

Note:

- All wires of indoor unit and outdoor unit should be connected by a professional.
- Only single unbroken electrical wires should be used. Spliced wires are not allowed.
- For heat pump models with electrical plug, the outlet must be reachable after finishing installation.
- For heat pump models without plug, a circuit breaker must be installed in the line. The circuit breaker should be all-pole parting and the contact parting distance should be more than 3mm (1/8 in).

Indoor Unit Installation

Step eight: bind up pipe

1. Bind the connection pipe, power cord and drain hose with tape.

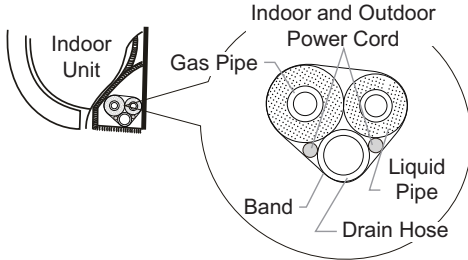

2. Reserve a certain length of drain hose and power cord for installation when binding them. When binding to a certain degree, separate the indoor power and then separate the drain hose.

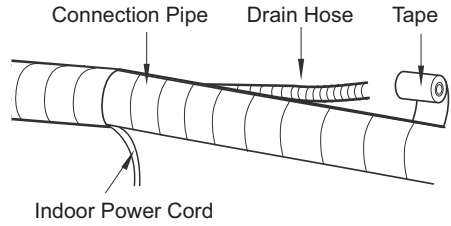

3. Bind them evenly.
4. The liquid pipe and gas pipe should be bound separately at the end.

Note:

- The power cord and control wire can't be crossed or winding.
- The drain hose should be bound at the bottom.

Step nine: hang the indoor unit

1. Put the bound pipes in the wall pipe and lead through the wall hole.
2. Hang the indoor unit on the wall-mounting frame.
3. Fill the gap between pipes and wall hole with sealer to prevent drafts.
4. Secure the wall pipe.
5. Check that the indoor unit is securely installed against the wall.

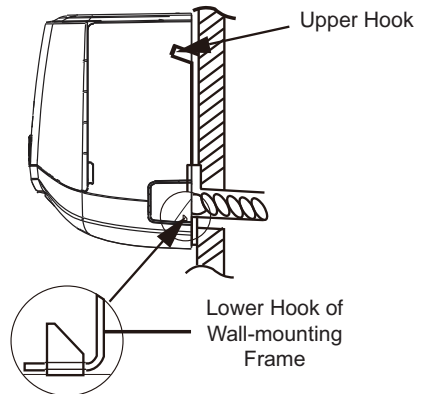
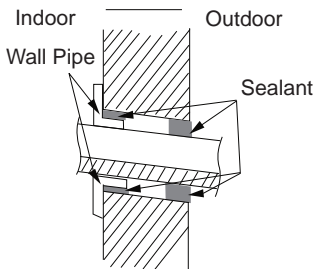

Note:

- Keep bends in drain line to a minimum number and degree to prevent blockage.

Outdoor Unit Installation

Step one: secure the support structure (select it based on installation needs)

1. Select installation location based on building construction and surroundings.
2. Secure the support of outdoor unit on the selected location with expansion screws.

Note:

- Take sufficient protective measures when installing the outdoor unit.
- Make sure the support can withstand at least four times of the unit weight.
- The outdoor unit should be installed at least 3cm (1-1/4 in) above the floor in order to install drain.
- For unit with cooling capacity of 2300W~5000W, 6 expansion screws are needed; for unit with cooling capacity of 6000W~8000W, 8 expansion screws are needed; for unit with cooling capacity of 10000W~16000W, 10 expansion screws are needed.

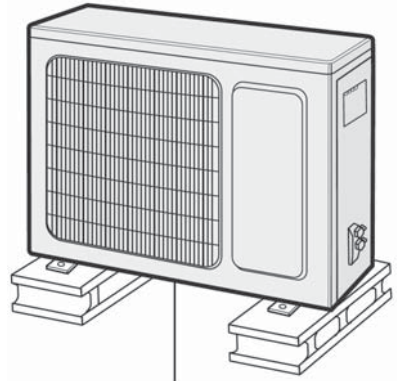

at least 3cm above the floor

Step two: install drain joint (Only for cooling and heating unit)

1. Connect the outdoor drain joint into the hole on the chassis, as shown in the picture below.
2. Connect the drain hose into the drain vent.

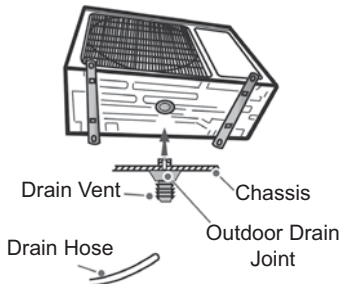

Step three: secure outdoor unit

1. Place the outdoor unit on the support.
2. Fasten the foot holes of outdoor unit with bolts.

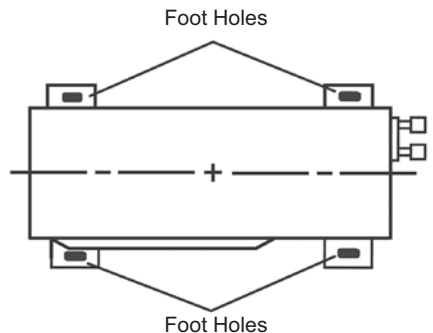

Outdoor Unit Installation

Step four: connect indoor and outdoor pipes

1. Remove the screw on the right handle of outdoor unit and then remove the handle.

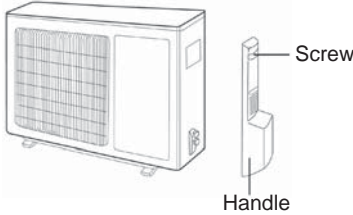

2. Remove the screw cap of valve and align the pipe joint at the bellmouth of pipe.

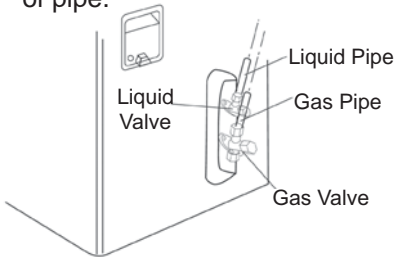

3. Tighten the union nut by hand.

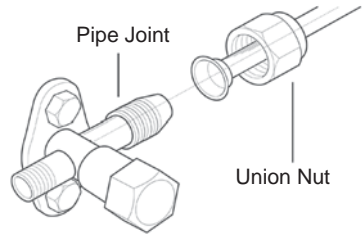

4. Tighten the union nut with torque wrench by referring to the sheet below.

Hex Nut Diameter	Tightening Torque (N-m)
Ø6mm (1/4 in)	15~20
Ø9.52mm (3/8 in)	30~40
Ø 12mm (1/2 in)	45~55
Ø16mm (5/8 in)	60~65
Ø19mm (3/4 in)	70~75

Step five: connect outdoor electric wire

1. Remove the wire clip; connect the power wire and signal control wire (only for cooling and heating unit) to the wiring terminal according to the color; attach them with screws.

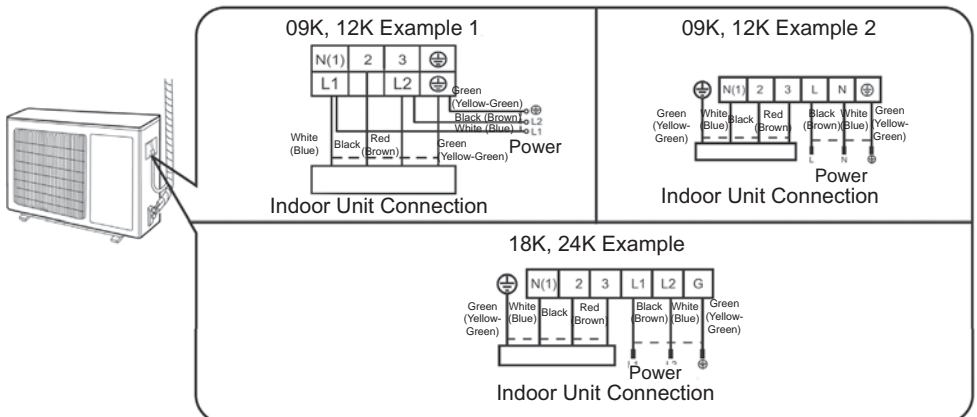

Note: The wiring board illustration is for reference only. Actual unit may vary slightly.

Outdoor Unit Installation

- Secure the power connection wire and signal control wire with the wire clip (for cooling and heating unit only).

Note:

- After tightening the screw, pull on the power cord lightly to check if it is secure.
- Power cord should be a single wire. Splices are not allowed.

Step six: Arrange the pipes

- The pipes should be placed neatly, or hidden, along the wall, with as few bends as possible. Min. radius of pipe bends should be 10 cm (4 in).
- If the outdoor unit is higher than the wall hole, you must make a U-shaped curve in the pipe before pipe goes into the room, to prevent rain from getting inside.

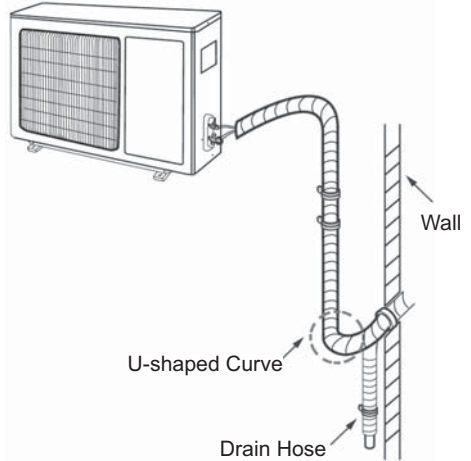

Note:

- The wall hole should be lower than the drain pipe connection on the indoor unit.
- Slope the drain hose slightly downwards with no trapping.

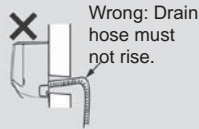

- The water hole must not be placed in water for proper draining.

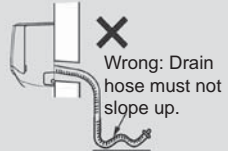
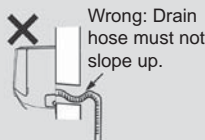
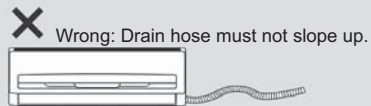
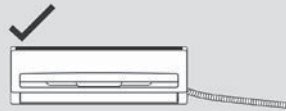
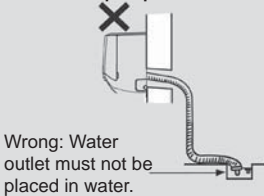

Vacuum Pumping

1. Remove the valve caps on the liquid valve and gas valve and the nut of refrigerant charging vent.
2. Connect the charging hose refrigerant charging of manifold gauge to the refrigerant charging vent of gas nut of refrigerant valve and then connect the other charging hose to the vacuum pump.
3. Open the manifold gauge completely and operate for 10-15 min to check if the pressure of manifold gauge remains at -0.1MPa .
4. Close the vacuum pump and maintain this status for 1-2 min to check if the pressure of manifold gauge remains at -0.1MPa . If the pressure decreases, there may be leakage.
5. Remove the manifold gauge, open the valve core of liquid valve and gas valve completely with hexagon wrench.
6. Tighten the screw caps of valves and refrigerant charging vent.

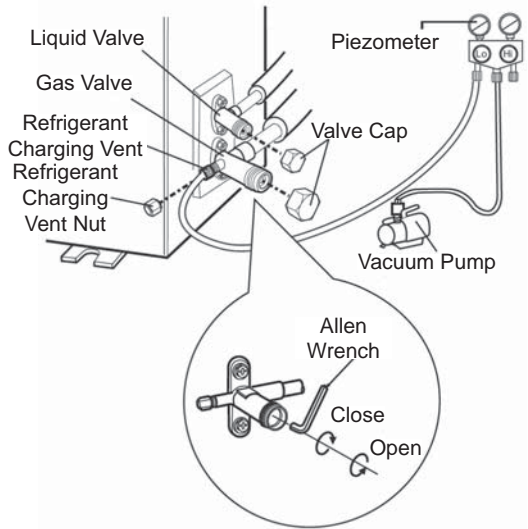

Leak Detection

1. With leakage detector:
Check if there is leakage with leakage detector.
2. With soapy water:
If leakage detector is not available, please use soapy water for leakage detection. Apply soapy water at the suspected leak location and keep it there for more than 3min. If you see air bubbles, there is a leak.

After Installation Checklist

- Check according to the following requirement after completing installation.

Items to check	Possible result
Has the unit been installed securely ?	The unit may fall, shake or emit noise.
Have you done the refrigerant leakage test?	It may cause insufficient cooling (heating) capacity.
Is heat insulation of pipeline sufficient?	It may cause condensation and water dripping.
Will water easily drain?	It may cause condensation and water dripping.
Does the voltage match voltage marked on the nameplate?	It may cause malfunction or damage.
Is electric wiring and pipeline installed correctly?	It may cause malfunction or damage.
Is the unit grounded securely?	It may cause short circuit.
Does the power cord match the specification?	It may cause malfunction or damage
Is there any obstruction in the air inlet and outlet?	It may cause insufficient cooling (heating) capacity.
Is the dust and debris from installation removed?	It may cause malfunction or damage
Are the gas valve and liquid valve of connection pipe open completely?	It may cause insufficient cooling (heating) capacity.
Is the inlet and outlet of piping hole covered?	It may cause insufficient cooling (heating) capacity or drafts.

Test Operation

1. Before testing operation
 - The client approves the installation.
 - Explain operation and other important notes to client.
2. Testing method
 - Turn on the power, press ON/OFF button on the remote controller to start operation.
 - Press MODE button to select AUTO, COOL, DRY, FAN and HEAT to check whether the operation is normal or not.
 - If the ambient temperature is lower than 16°C (61°F), the heat pump can't start cooling

Connection Pipe Configuration

1. Standard length of connection pipe
 - 5m (16 ft), 7.5m (25 ft), 8m (26 ft).
2. Min. length of connection pipe is 3m (10 ft).
3. Maximum length of connection pipe and maximum height difference.

Cooling Capacity	Max length of connection pipe	Max height difference
5000Btu/h (1465W)	15M (50 ft)	5M (16 ft)
7000Btu/h (2051W)	15M (50 ft)	5M (16 ft)
9000Btu/h (2637W)	15M (50 ft)	5M (16 ft)
12000Btu/h (3516W)	20M (65 ft)	10M (33 ft)
18000Btu/h (5274W)	20M (65 ft)	10M (33 ft)

Cooling Capacity	Max length of connection pipe	Max height difference
24000Btu/h (7032W)	25M (65 ft)	10M (33 ft)
28000Btu/h (8204W)	30M (100 ft)	10M (33 ft)
36000Btu/h (10548W)	30M (100 ft)	20M (65 ft)
42000Btu/h (12306W)	30M (100 ft)	20M (65 ft)
48000Btu/h (14064W)	30M (100 ft)	20M (65 ft)

Connection Pipe Configuration

4. The additional refrigerant oil and refrigerant charging required after extending connection pipe
- After the length of connection pipe is extended for 10m (33 ft) at the basis of standard length, you should add 5ml (3/16 oz) of refrigerant oil for each additional 5m (16 ft) of connection pipe.
 - The calculation method of additional refrigerant amount (on the basis of liquid pipe):

Additional refrigerant amount = additional length of liquid pipe × additional refrigerant charging amount per foot.
 - Basing on the length of standard pipe, add refrigerant according to the requirement as shown in the table. The additional refrigerant charging amount per foot is different according to the diameter of liquid pipe. See the following table.

Additional refrigerant charging amount for R410A.

Diameter of connection pipe mm (in)		Outdoor unit throttle g/m (oz/ft)	
Liquid Pipe	Gas Pipe	Cooling Only	Cooling & Heating
∅ 6 (1/4)	∅ 9.52 or 12 (3/8 or 1/2)	15 (1/6)	20 (1/5)
∅ 6 or 9.52 (3/8 or 1/2)	∅ 16 or 19 (5/8 or 3/4)	15 (1/6)	50 (1/2)
∅ 12 (1/2)	∅ 19 or 22.2 (3/4 or 7/8)	30 (1/3)	120 (1-1/3)
∅ 16 (5/8)	∅ 25.4 or 31.8 (1 or 1-1/4)	60(2/3)	120 (1-1/3)
∅ 19 (3/4)	-	250 (2-2/3)	250 (2-2/3)
∅ 22.2 (7/8)	-	350 (3-3/4)	350 (3-3/4)

Pipe Expansion Method

Note:

Improper pipe expanding is the main cause of refrigerant leakage. Please expand the pipe according to the following steps:

A. Cut the pipe

- Confirm the distance between the indoor and outdoor units.
- Cut the required length with pipe cutter.

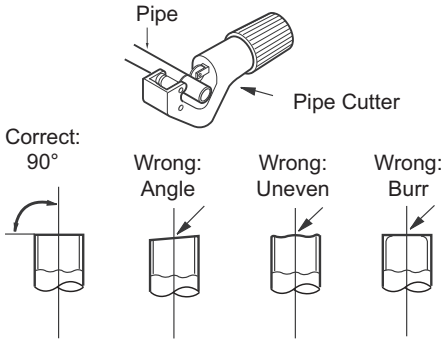

B. Remove the burrs

- Remove the burrs with deburring tool and prevent the burrs from getting into the pipe.

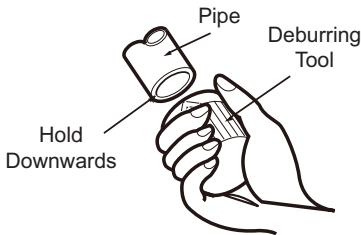

C. Put on suitable insulating pipe

D. Put on the union nut

- Remove the union nut on the indoor connection pipe and outdoor valve; install the union nut on the pipe.

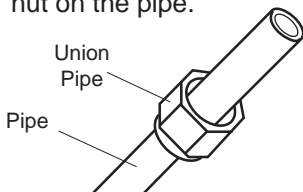

E. Expand the port

- Expand the port with expander.

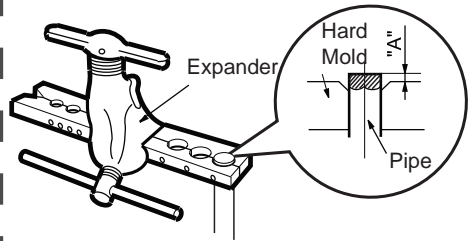

Note:

- "A" is different according to the diameter, please refer to the table below:

Outer diameter mm (in)	A mm (in)	
	Max	Min
Ø6~6.35 (1/4)	1.3 (1/16)	0.7 (1/32)
Ø9.52 (3/8)	1.6 (1/16)	1.0 (1/16)
Ø12~12.7 (1/2)	1.8 (1/16)	1.0 (1/16)
Ø15.8~16 (5/8)	2.4 (3/32)	2.2 (3/32)

F. Inspection

- Check the quality of expanding port. If there is any blemish, expand the port again according to the steps above.

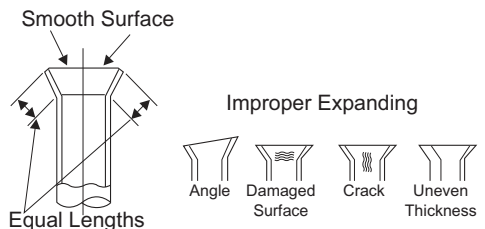

Optional Wired Controller

If the product you bought is equipped with wired controller, please refer to the following.

1. Display

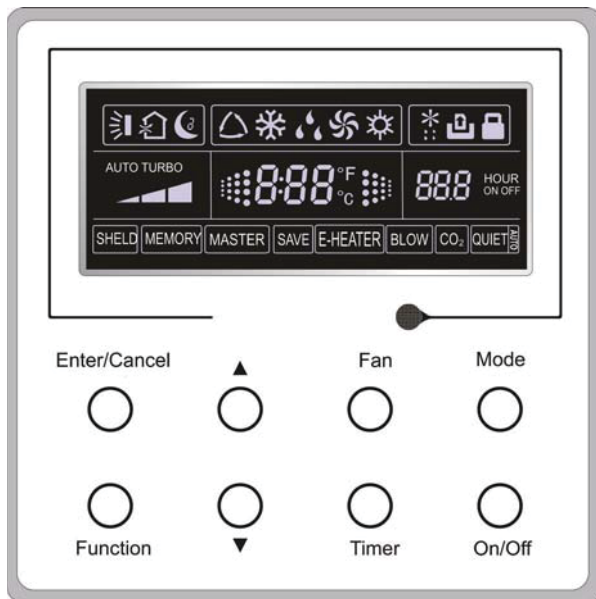

Fig. 1.1.1 Wired Controller

1.1. LCD Display of Wired Controller

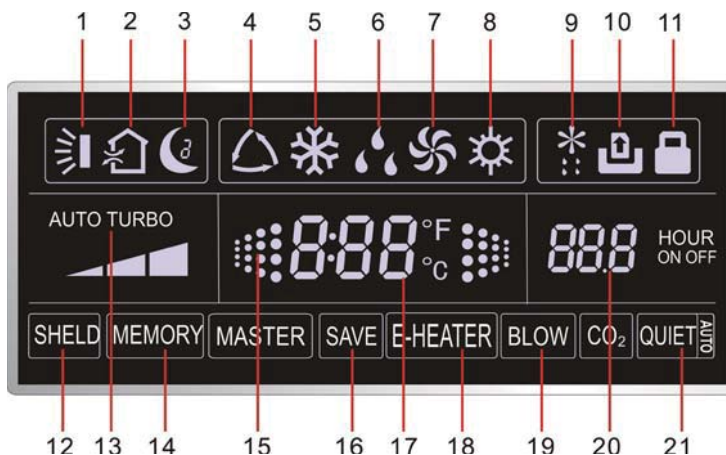















Fig. 1.1.2 LCD Display

Optional Wired Controller

1.1. Instructions to LCD Display (not all functions available on all models).

Number	Symbol	Description
1		Swing function
2		Air exchange function (this function is yet unavailable for this unit).
3		Sleep function (Only sleep 1).
4		Auto mode
5		Cooling mode
6		Dry mode
7		Fan mode
8		Heating mode
9		Defrosting function for the outdoor unit.
10		Gate-control function (this function is yet unavailable for this unit).
11		Lock function.
12	SHIELD	Shield functions (Button operation, temperature setting, On/Off operation, Mode setting are disabled by the remote monitoring system.)
13	TURBO	Turbo function
14	MEMORY	Memory function (The indoor unit resumes the original setting after power failure and recovery).
15		This symbol will blink while the unit is turned on and will disappear when unit is turned off.
16	SAVE	Energy-saving function (this function is yet unavailable for this unit).
17		Ambient/setting temperature value
18	E-HEATER	Electric auxiliary heating function.
19	BLOW	Blow function.
20		Timing value.
21	QUIET	Quiet function (two types: quiet and auto quiet) (this function is yet unavailable for this unit).



Optional Wired Controller

1. Buttons

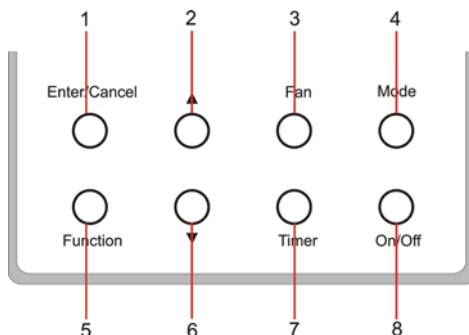
1.1. Button Layout



1.2. Button Function

Number	Name	Function
1	Enter/Cancel	Function selection and cancellation.
2	▲	1. Running temperature setting of the indoor unit, range:16~30°C (61~86°F)
6	▼	2. Timer setting, range:0.5-24 hr.
3	Fan	Fan speed setting: high/middle/low/auto.
4	Mode	Mode setting: Cooling/Heating/Fan/Dry/Auto.
5	Function	Switchover among the functions of Turbo/Save/E-heater/Blow etc.
7	Timer	Timer setting.
8	On/Off	Turn on/off the indoor unit
4 + 2	▲ + Mode	Press them for 5s while unit is off to enter/cancel the Memory function (If memory is set, after power failure and recovery the unit will resume the original setting state. If not, after power recovery, unit will default to off state. Memory off is default.
3 + 6	Fan + ▼	By pressing them at the same time under off state of the unit,  will be displayed on the wired controller for the cooling only unit, while  will be displayed on the wired controller for the cooling and heating unit.
2 + 6	▲ + ▼	While unit is turned off, press them at the same time for 5s to enter the lock state. Signals from any other button pressed will be ignored while in lock state. Repress them for 5s to exit this state.

Optional Wired Controller

1. Operation Instructions

1.1. On/Off

Press On/Off to turn on or off.

Note: Fig. 3.1.1 indicates Off status. Fig. 3.1.2 indicates On status.



Fig. 3.1.1 OFF Status

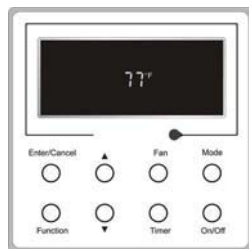
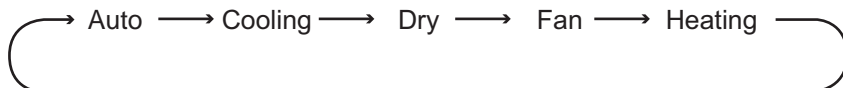

Fig. 3.1.2 ON Status

1.2. Mode Setting

Under On status, press the Model switch for the operation modes: Auto - Cooling - Dry - Fan - Heating.



1.3. Temperature Setting

Press ▲ or ▼ to increase/decrease the temperature setting. Press and hold either button and , the temperature will be increased or decreased by 1°C (°F) every 0.5s, as shown in Fig. 3.3.1.

In the Cooling, Dry, Fan or Heating mode, the temperature setting range is 16°C~30°C (61~86°F).

In the Auto mode, the setting temperature can not be adjusted.

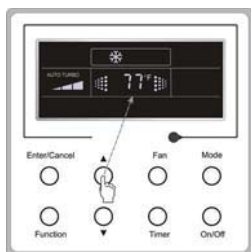

Fig. 3.3.1

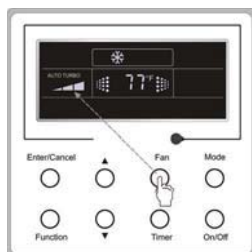

Fig. 3.4.1

Optional Wired Controller

1.4. Fan Setting

Under the “On” state of the unit, press Fan to change the fan speed of the indoor unit as shown in Fig. 3.4.1.



1.5. Timer Setting

Under on-state of the unit, press the Timer button to set timer off of setting. Under off-state of the unit, press Timer button to set timer on setting.

• Timer on setting:

Under Off status without timer setting, if Timer button is pressed, LCD will display xx Hour, with ON blinking. Press ▲ or ▼ button to adjust timer on and then press Timer to confirm.

• Timer off setting:

Under on-state of the unit without timer setting, if Timer button is pressed, LCD will display xx Hour, with OFF blinking. Press ▲ or ▼ button to adjust timer on and then press Timer to confirm.

• Cancel timer:

After setting timer, if Timer button is pressed, the timer setting is canceled and LCD will no longer display xx.

Timer off setting under the “On” state is shown in Fig. 3.5.1.

Timer On setting under Off status is shown in Fig. 3.5.2.

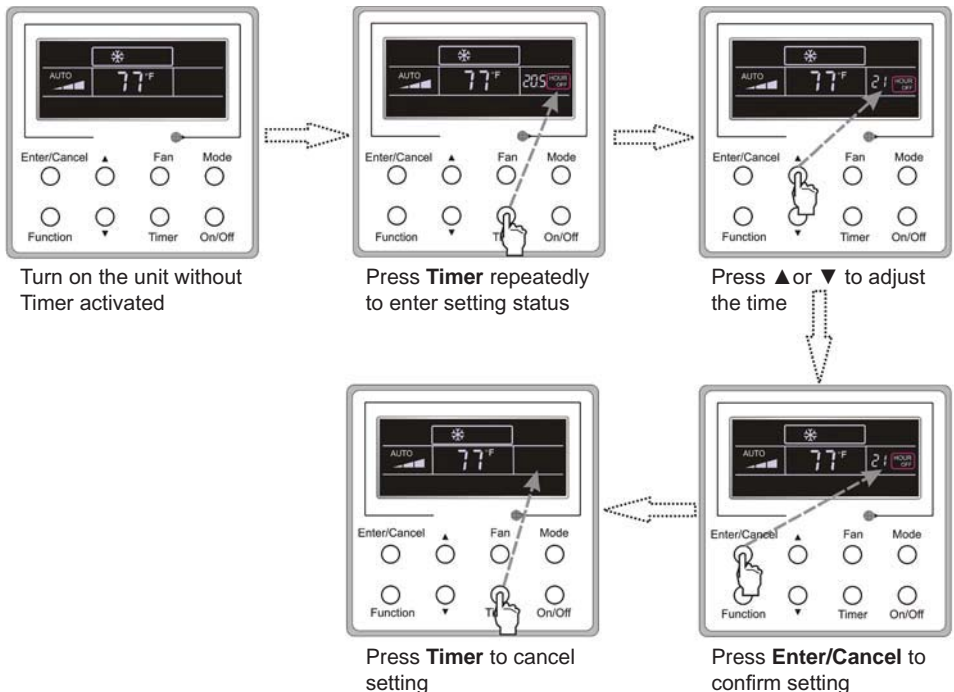

Fig. 3.5.1 Timer Setting Under ON Status

Optional Wired Controller

Timer range: 0.5-24hr. Every press of ▲ or ▼ will make the set time increased or

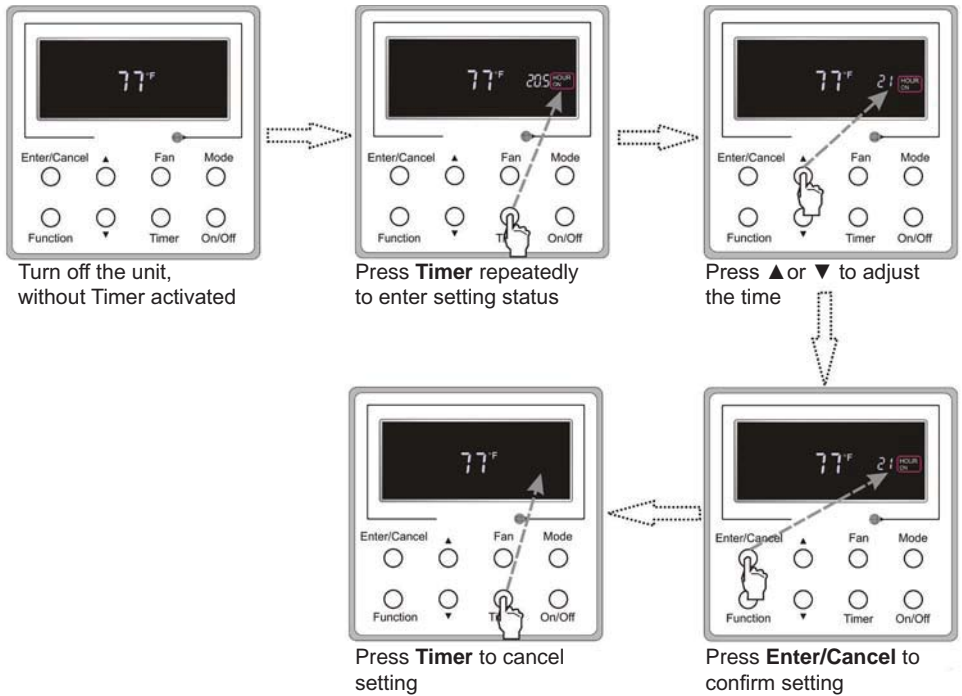



Fig. 3.5.2 Timer On Setting Under OFF Status

decreased by 0.5hr. Press and hold either button and, the set time will increase/decrease by 0.5hr every 0.5s.

Optional Wired Controller

1.1. Swing Setting

Swing On: While unit is in ON state, press the Function button. You will have to press it several times until the  symbol begins to blink. Press Enter/Cancel to engage Swing On.

Swing Off: While the Swing setting is on, press the Function button. You will have to press it several times until the  begins to blink. Press Enter/Cancel to cancel. Swing setting is shown as Fig. 3.6.1.

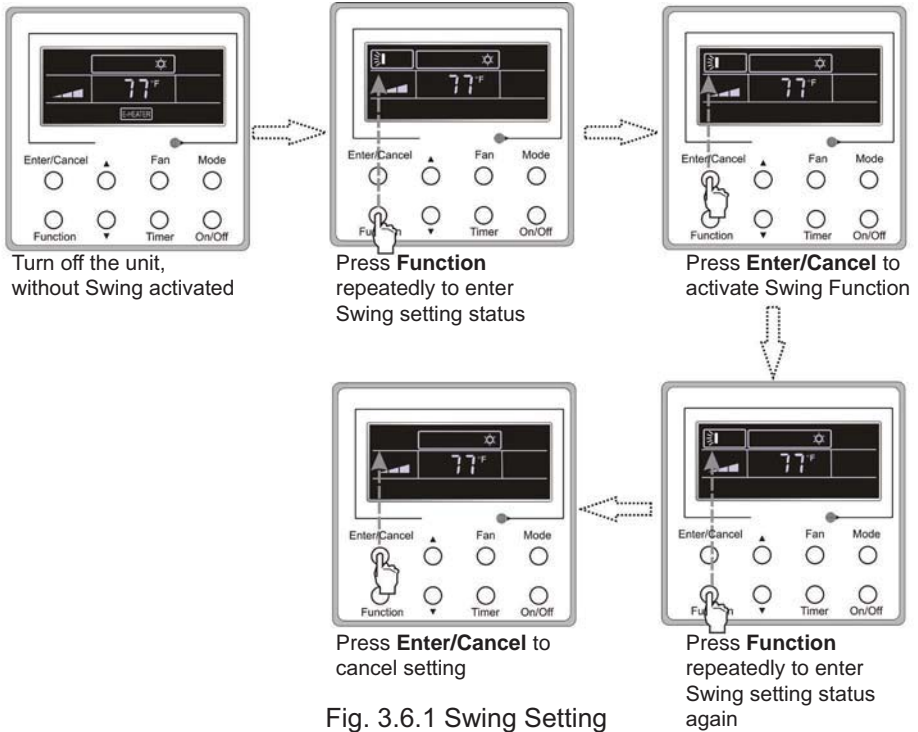

Fig. 3.6.1 Swing Setting

Notes:

1. Sleep, Turbo or Blow settings are turned on and off the same as the Swing setting.
2. Enter/Cancel must be selected within 5 seconds after making selection or setup will quit. Settings will not be saved and display will return to default screen.

Optional Wired Controller

1.1. Sleep Setting

Sleep on: While the unit is in ON state, press the Function button until the sleep symbol (crescent moon) blinks. Press Enter/Cancel to confirm. Sleep symbol will stop blinking.

Sleep off: When Sleep function is on, press Function button until sleep symbol blinks. Press Enter/Cancel to cancel. Sleep symbol will disappear.

In the Cooling or Dry mode, the set temperature will increase by 1°C/F after one hour and by another degree after a second hour. The unit will continued to run at this set temperature until Sleep function is turned off.

In the Heating mode, the set temperature will decrease by 1°C/F after one hour and another degree after a second hour. The unit will continue to run at this temperature until the Sleep function is turned off.

Sleep setting is shown as Fig. 3.7.1.

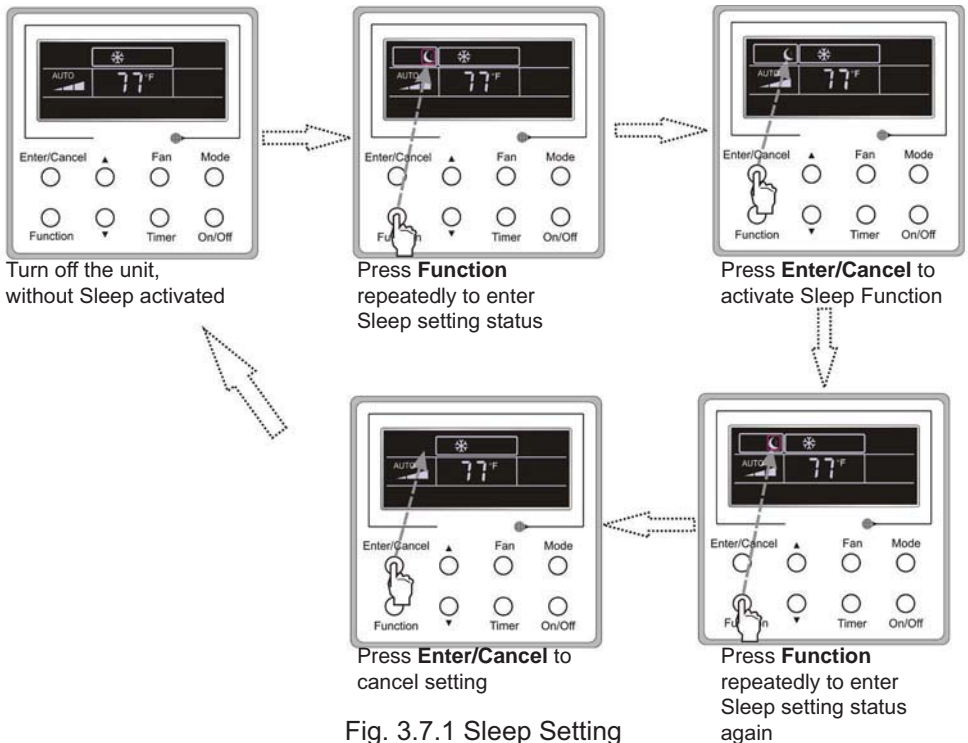

Fig. 3.7.1 Sleep Setting

Optional Wired Controller

1.2. Turbo Setting

Turbo function: A separate function from the fan setting, the Turbo function is a very high speed so the unit can attain the room set temperature more quickly.

In the Cooling or Heating mode, press Function till the unit enters the Turbo setting status and then press Enter/Cancel to confirm the setting.

When the Turbo function is activated, press Function to enter the Turbo setting status and then press Enter/Cancel to cancel this function.

Turbo function setting is as shown in Fig. 3.8.1.

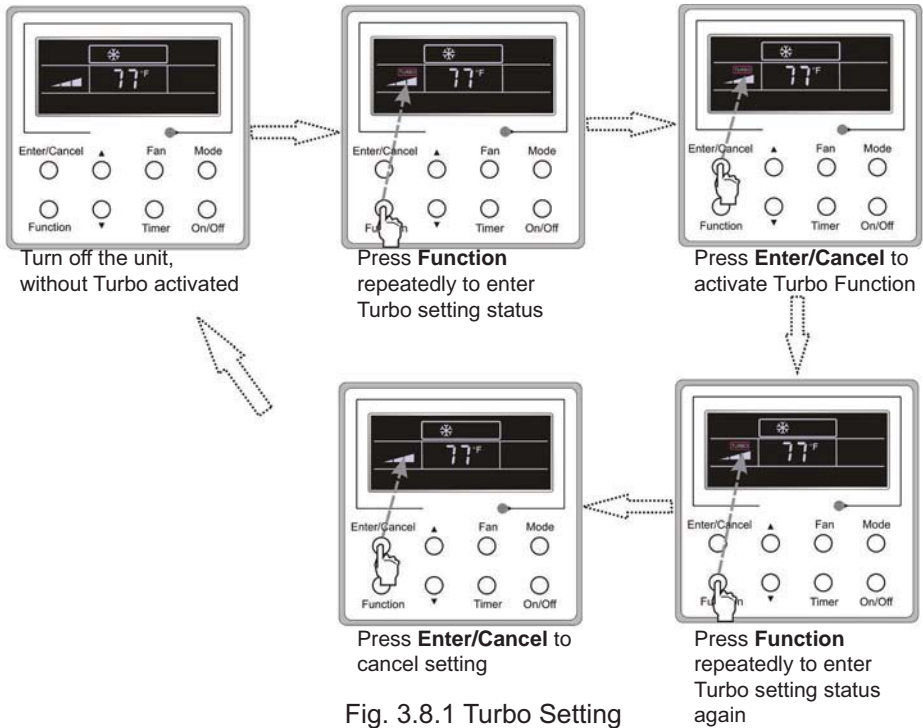

Optional Wired Controller

1.1. E-heater Setting

E-heater (auxiliary electric heating function): In the Heating mode, E-heater is allowed to be turned on for efficiency.

Once the wired controller or the remote controller enters the Heating mode, this function will be turned on automatically.

Press Function in the Heating mode til the unit enters E-heater setting interface and then press Enter/Cancel to cancel this function.

Press Function to enter the E-heater setting status, if the E-heater function is not activated, and then press Enter/Cancel to activate it.

The setting of this function is shown as Fig. 3.9.1 below.

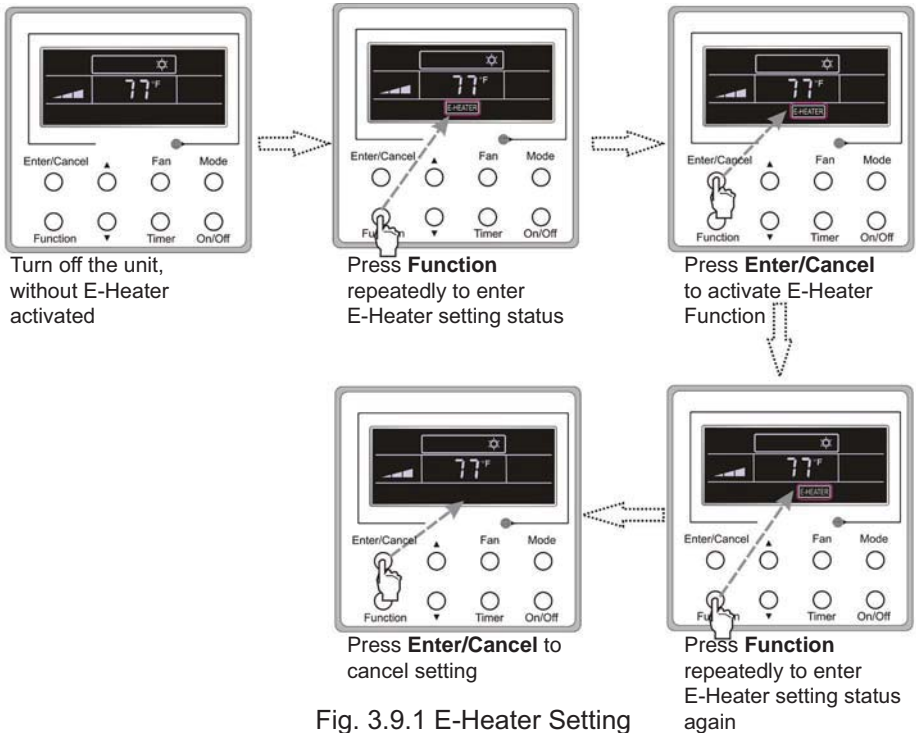

Optional Wired Controller

1.2. Blow Setting

Blow function: If unit is turned off while in cooling mode with Blow activated, the fan will continue run at low speed for 2 minutes to dry the inside of the unit. This will help prevent mildew.

In the Cooling or Dry mode, press Function till the unit enters the Blow setting status and then press Enter/Cancel to activate this function.

When the Blow function is activated, press Function to the Blow setting status and then press Enter/Cancel to cancel this function.

Blow function setting is as shown in Fig. 3.10.1.

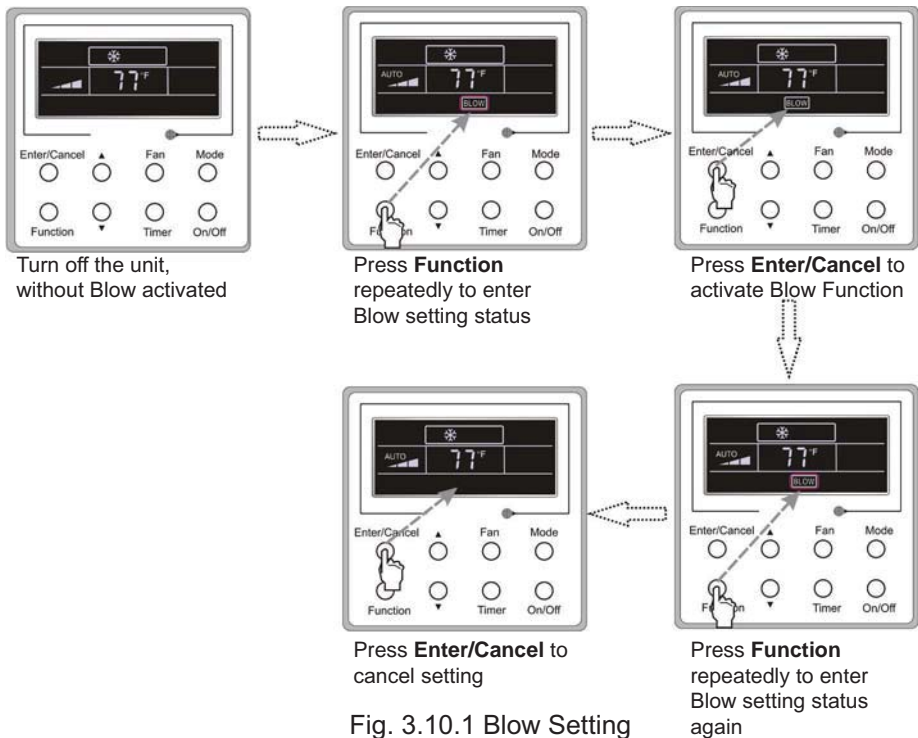

Fig. 3.10.1 Blow Setting

Notes:

1. Sleep, Turbo or Blow settings are turned on and off the same as the Swing setting.
2. Enter/Cancel must be selected within 5 seconds after making selection or setup will quit. Settings will not be saved and display will return to default screen.

Optional Wired Controller

1.1. Other Functions

a. Lock

With the unit in "Off" state of the unit, press ▲ and ▼ at the same time for 5s till the wired controller enters the Lock function. In this case, LCD displays .

Repress these two buttons at the same time for 5s to exit this function.

Under the Lock state, no other buttons will operate.

b. Memory

Memory switch over: Under the "Off" state of the unit, press Mode and ▲ at the same time for 5s to switch memory states between memory on and memory off. When this function is activated, Memory will be displayed.

When this function is set, the unit will remember settings and resume operation after a power failure. If this function is not set, after a power failure, unit will default to OFF state.

Memory contents: On/ Off, Mode, set temperature, set fan speed and Lock function.

1. Installation and Disassembly

1.1. Connecting the Wired Controller Signal Line

- Open the cover of the electric control box on the indoor unit.
- Lead the wired controller single wire through the rubber ring.
- Connect the wired controller signal line to the 4-pin socket of the indoor unit PCB.
- Secure the signal wire with ties.
- The communications distance between the main board and the wired control can be up to 20 meters (65 ft) (the standard distance is 8 meters (25 ft)).

1.2. Wired Controller Installation

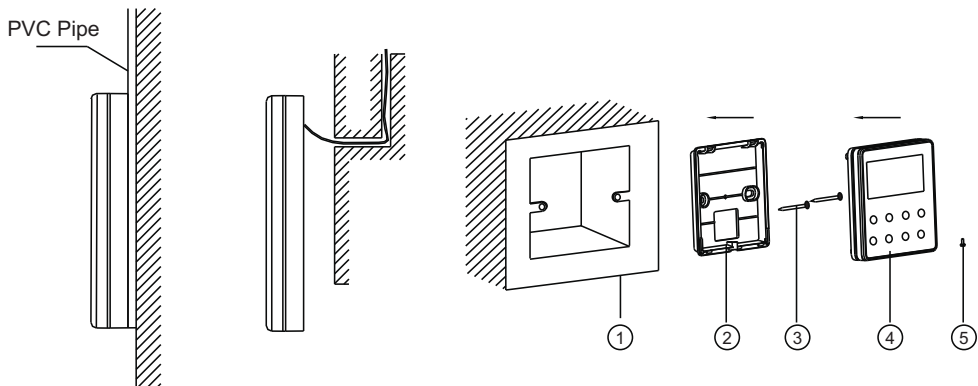

Fig. 4.1 Accessories for Wired Controller Installation

Table 4.1

No.	1	2	3	4	5
Name	Socket box embedded in the wall	Wired Controller Soleplate	Screw M4X25	Wired Controller Front Panel	Screw ST 2.9x6

Optional Wired Controller

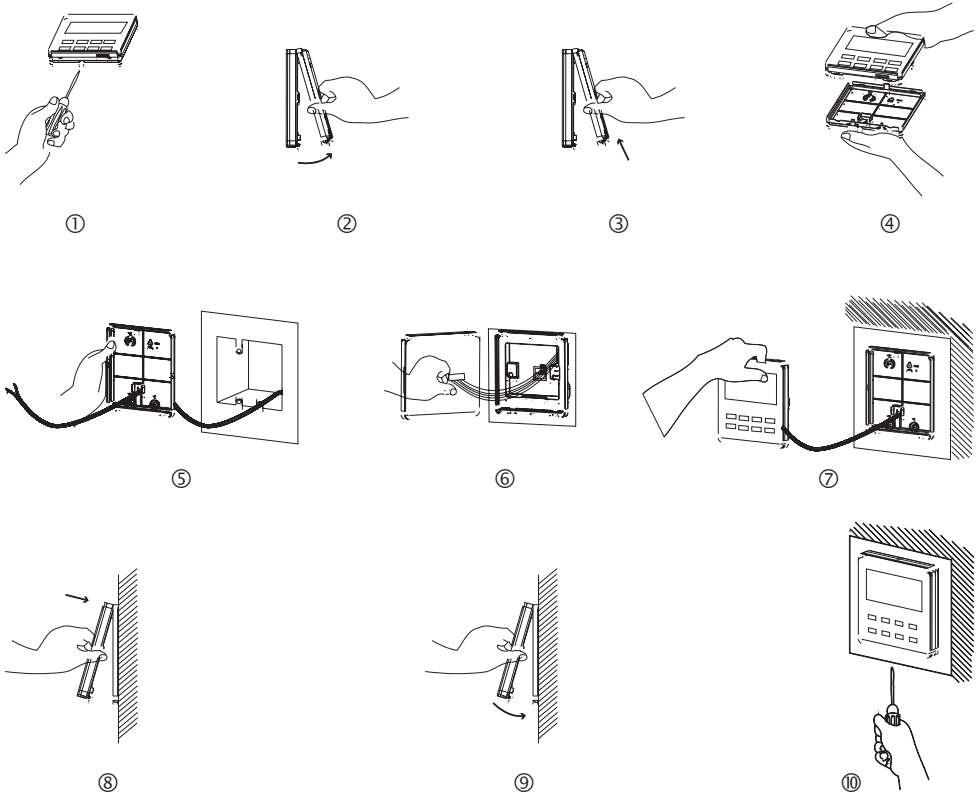

Fig. 4.2

Fig. 4.2 shows the installation steps of the wired controller, but there are some issues that need your attention.

- Before installing wired controller make sure power supply is turned off. Do not turn power back on until installation is complete.
- Pull out the four-core twisted pair line from the installation holes and then lead it through the rectangular hole behind the soleplate of the wired controller.
- Mount the wired controller soleplate to the wall over the installation hole and then secure it with screws M4X25.
- Insert the four-core twisted pair line into the slot of the wired controller and then buckle the front panel and the soleplate of the wired controller together.
- Attach the front panel and soleplate tightly with screws ST2.9x6

⚠CAUTION!

Please pay special attention to the followings during the connection to avoid malfunction due to electromagnetic interference.

- Separate the signal and communication lines of the wired controller from the power cord and connection lines between the indoor and outdoor unit, a minimum of 20cm (8 in), otherwise the communication of the unit will probably work abnormally.
- If the heat pump unit is installed near electromagnetic field, then the signal and the wired controller communications lines must be shielded twisted pair wires.

Optional Wired Controller

1.1. Wired Controller Disassembly

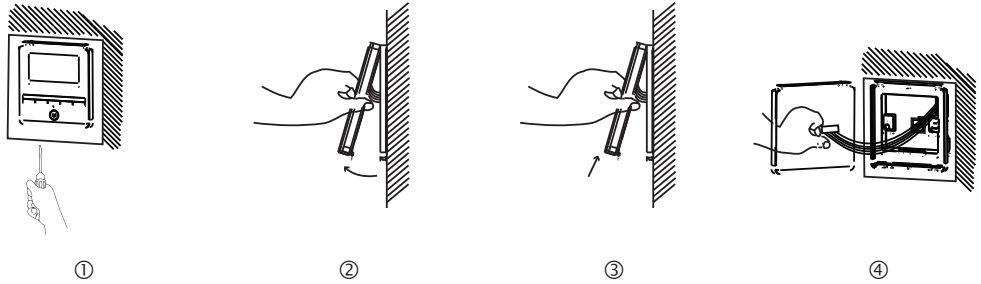

1. Error Display

If there is an error occurring during the operation of the system, the error code will be displayed on the LCD, as show in Fig. 5.1. If multi errors occur at the same time, their codes will be displayed consecutively.

Note: In event of any error, please turn off the unit and contact the professionally skilled personnel.

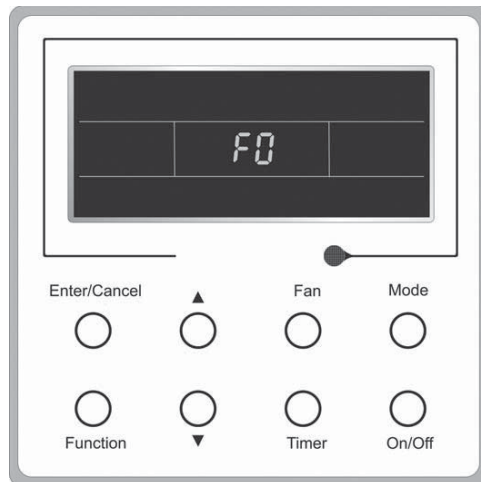

Fig. 5.1

Optional Wired Controller

Table 5.1 Error Code Description

Error Code	Description
b5	Indoor unit liquid valve temperature sensor open/short circuited
b7	Indoor gas valve temperature sensor open/ short circuited
C5	Jumper error
dn	Communication line disconnected or expansion valve error
E1	High pressure protection
E2	Anti-freezing protection
E3	Low pressure protection
E4	High discharge temperature protection
E5	Whole unit over-current protection
E6	Indoor and outdoor communication error
E7	Running Model conflict
E8	Overload protection
E9	Indoor unit full water error
En	Frequency restricted/reduced with IPM current protection
EU	Frequency restricted/reduced with IPM temperature protection
F0	System charge shortage or blockage protection
F1	Return air temperature sensor open/ short circuited
F2	Evaporator temperature sensor open/ short circuited
F3	Outdoor ambient temperature sensor open/ short circuited
F4	Outdoor unit condenser mid-tube temperature sensor open/short circuited
F5	Discharge temperature sensor open/ short circuited
F6	Frequency restricted/reduced with overload protection
F8	Frequency restricted/reduced with whole unit current protection
F9	Frequency restricted/reduced with high discharge temperature
FH	Frequency restricted/reduced with antifreezing protection

Error Code	Description
Fo	Pump-down
H1	Forced defrosting
H3	Compressor overheating protection
H5	IPM Current protection
H6	Motor stalling
H7	Compressor desynchronized
Hc	PFC protection
HE	Compressor demagnetization protection
L3	Outdoor fan 1 error protection
L9	Over-power protection
LA	Outdoor fan 2 error protection
Lc	Compressor startup failure
Ld	Compressor phase loss/reversal protection
LE	Compressor stalling
LF	Over-speeding
LP	Indoor and outdoor units unmatched
P5	Over phase current protection
P6	Drive board communication error
p7	IPM temperature sensor open/short circuited
P8	IPM Temperature Protection
P9	AC contactor protection
Pd	Sensor connection protection
PE	Temperature drift protection
PF	Drive board temperature sensor error
PH	DC bus over-voltage protection
PL	DC bus under-voltage protection
PP	AC input voltage abnormal
PU	Capacitor charging error
U1	"Compressor phase current sensing circuit error"
U3	DC bus voltage drop error
U5	Whole unit current sensing circuit error
U7	4-way valve reversing error
U8	PG motor zero-crossing protection

Specifications & illustrations subject to change without notice or incurring obligations.
O'Fallon, MO (02/21) © Nortek Global HVAC, LLC 2021. All Rights Reserved. 577E-0221



66129920530