

Installation & Operating Instructions For Air Conditioning Units

CLICK ANYWHERE on THIS PAGE to RETURN TO GOETTL AIR CONDITIONING, AGE & MANUALS at InspectApedia.com

Manufactured By
GOETTL AIR CONDITIONING, INC.
P.O. Box 52029, Phoenix, Arizona 85072-2029

TABLE OF CONTENTS

	PAGE
I. INTRODUCTION	1
II. DIMENSIONS	2
III. POWER SUPPLY & WIRING.....	3
IV. INSTALLATION	4
V. START UP/CHECK-OUT PROCEDURE	6
VI. ELECTRICAL OPERATION.....	6
VII. RESISTANCE HEATERS	7
VIII. OPERATION AND MAINTENANCE	7
IX. WIRING DIAGRAM.....	9

INSTALLATION AND OPERATING INSTRUCTION MANUAL

SC MODELS COOLING ONLY – 1 1/2 - 5 1/2 TONS

I. INTRODUCTION

Please take a few minutes to read our instructions before you install and use your air conditioner. This will help you obtain the full value from your air conditioner. It will also help you avoid any needless service costs that result from causes we cannot control and cannot cover in our guarantee.

RULES FOR INSTALLATION AND SAFE OPERATION

1. Read these rules and the instructions carefully. Failure to follow the rules and the instructions could cause a malfunction of the air conditioning unit resulting in injury, death and/or property damage.
2. Check your local codes and utility standards. The installation must comply with their rules.
3. Shut off the electric power before making connections on the unit or removing panels for servicing. (There may be more than one disconnect).
4. Refer to Section VIII for maintenance procedures.
5. Do not operate this unit at outdoor temperatures below 60°F on cooling.
6. The components of an air conditioner may have sharp edges or protrusions which can cut you. The tubing and compressor contain high pressure refrigerant. They must not be exposed to high temperature or be punctured. When installing or servicing the air conditioner, be extremely careful to avoid injury.

The importance of proper installation cannot be overemphasized. The best designed unit will appear to operate poorly if installed improperly. Unlike the small appliance where quality of operation can usually be determined as it leaves the factory, the performance of an air conditioner depends, to a large extent, on its installation.

Problems always occur if the installer does not take precautions in the following areas:

- Wire Size** - Inadequate wire sizes can cause an excessive voltage drop, causing the compressor and fan motors to operate at undesirably low voltage rates.
- Duct Size** - Inadequate duct size, elbows, distributors or registers can restrict air flow.
- Duct Openings** - Improperly sealed duct sections can cause considerable loss in cooling capacity due to air leakages.
- Duct Insulation** - Inadequate duct insulation in attic space will cause heat gain in the system.
- Refrigerant Charge** - Unit is precharged, but should a change be necessary, it should be verified against the operating system pressures, temperatures, and current draws as specified in the catalog.

These air conditioners have proven their reliability over several decades. Years of research, engineering and only the highest quality component parts and workmanship have gone into these units to make them the most reliable in the industry. Before a model is released for production, it undergoes a battery of tests in environmental test rooms with conditions of up to 120°F desert temperatures.

II. DIMENSIONS

It is very important that the ducts for a self-contained system be properly sized, installed, sealed, and insulated for the best performance of the system. It is recommended that both the supply and the return duct be insulated (2")

when installed in an unconditioned area. Where the supply duct is exposed to the outdoor temperatures, vapor barrier material should be used. All duct work should be installed in accordance with ASHRAE or NAHB.

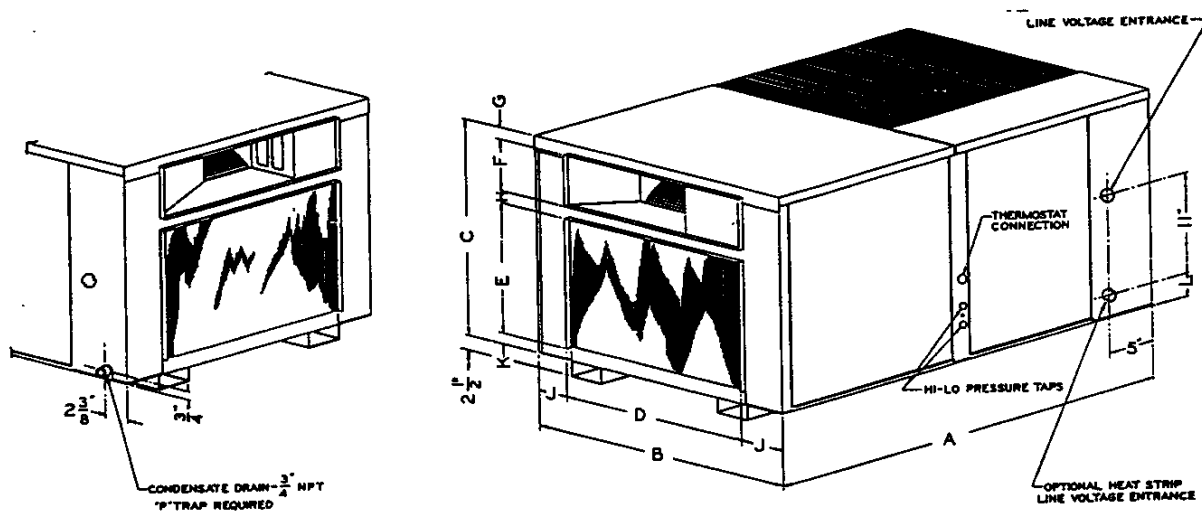

SC MODELS

Model	A	B	C	D	E	F	G	H	J	K	L
181F1	43 1/4	32 3/8	24	20	14 1/2	6	1	1	6 3/16	1 1/2	2 1/2
245F2	49 1/4	33 3/4	30	21	14 1/2	6	7	1	6 3/8	1 1/2	2 1/2
305F2	49 1/4	33 3/4	30	21	14 1/2	6	7	1	6 3/8	1 1/2	2 1/2
365F1	49 1/4	33 3/4	30	21	20 1/2	6	1	1	6 3/8	1 1/2	2 1/2
425F	49 1/4	33 3/4	30	21	17	9 3/8	1 1/8	1	6 3/8	1 1/2	2 1/2
485F	57 3/4	44 3/8	30 1/4	32	16 1/4	10	1 1/4	1	6 3/16	2	2 3/4
605F	57 3/4	44 3/8	30 1/4	32	16 1/4	10	1 1/4	1	6 3/16	2	2 3/4
662A	57 3/4	44 3/8	34 1/4	34	23 1/2	7	1	1	5 1/8	1 3/4	2 3/4

* See Fig. 2

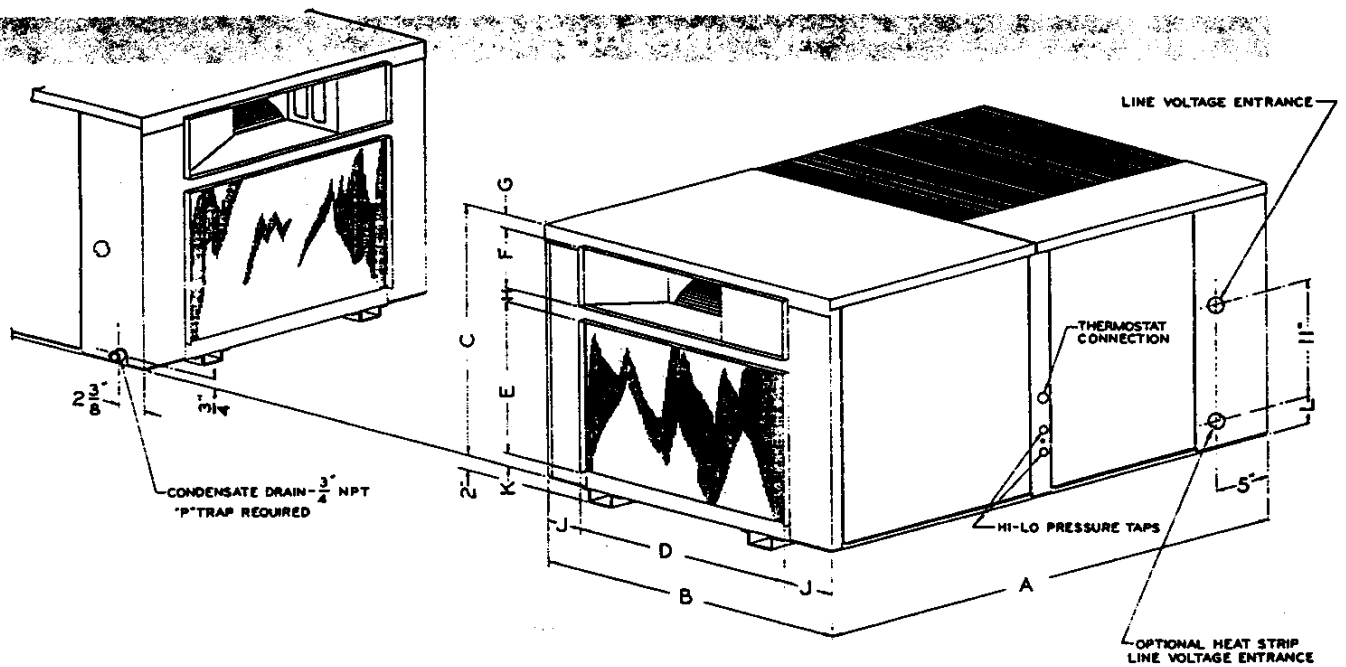

III. POWER SUPPLY & WIRING

Page 9 shows a typical wiring diagram for the various units. However, each unit will have its appropriate wiring diagram attached to the access panel of the wiring control section. **All wiring and fusing must comply with local and national electrical code requirements.**

The 24 volt control circuit connections are made at the right side of the panel (See figs. 1 and 2). The main power connections are made

at the "L" terminals of contractor, through knockout in side of unit. These connections must be tight and electrically secure. A fused disconnect must be installed at the unit location. When the unit is outdoors, the fused disconnect must be weather tight. The fuse(s) should be dual element type. Fuse and ampacity ratings are listed in the table below and also on the rating plate on the unit.

CAUTION: Unit must always be grounded with a suitable ground connection.

ELECTRICAL DATA AT 230V

Compressor	Locked Rotor Amps	1 Ph	48.0	60.0	72.5	88.0	104.0	129.0	169.0	147.0
		3 Ph*	-	-	-	77.0	88.0	99.0	123.0	150.0
	Rated Load Amps ¹	1 Ph	9.0	11.5	13.5	16.0	17.9	23.7	25.0	30.8
		3 Ph*	-	-	-	10.3	12.5	13.5	18.0	17.3
Outdoor Motor	Full Load Amps ¹	1 Ph	1.3	1.3	1.3	2.0	1.9	1.9	1.8	3.1
		3 Ph*	-	-	-	2.0	1.9	1.9	1.8	3.1
Indoor Motor	Full Load Amps ¹	1 Ph	1.2	1.3	1.4	2.4	3.1	3.3	4.0	5.1
		3 Ph*	-	-	-	2.4	3.1	3.3	4.0	5.1
Maximum Fuse Size, Amps		1 Ph	20.0	25.0	30.0	40.0	45.0	55.0	60.0	60.0
		3 Ph*	-	-	-	25.0	30.0	35.0	45.0	45.0
Minimum Circuit Ampacity		1 Ph	13.8	17.0	19.6	24.4	27.4	34.9	37.0	47.0
		3 Ph*	-	-	-	17.3	20.6	22.1	28.3	29.8

¹Based on UL Operating Conditions. *480V units available on special order.

IV. INSTALLATION

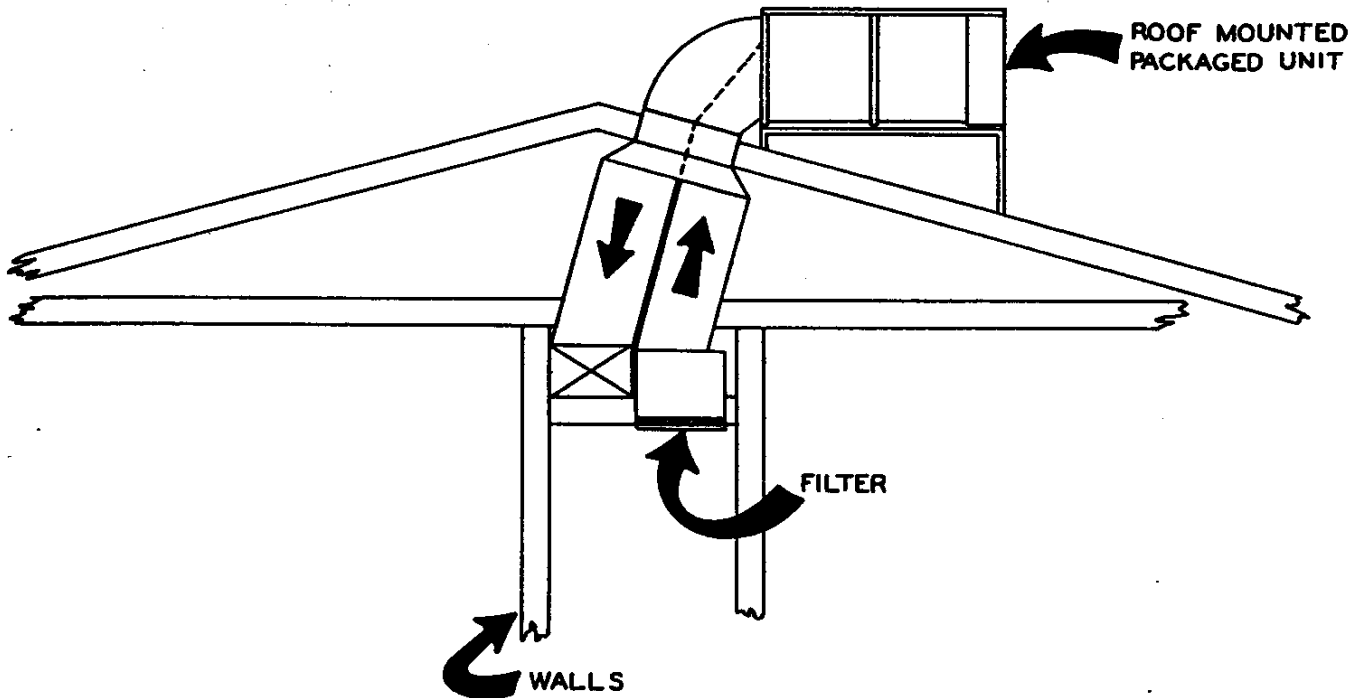

TYPICAL ROOF MOUNTED INSTALLATION

This system is a completely self-contained cooling unit with all components in one cabinet. It is shipped completely charged with the proper amount of refrigerant. The unit is ready for operation after connecting duct work, condensate drain and power supply. An adhesive backed soft-foam weather strip or caulking must be attached on the horizontal channel between the supply and return air openings as shown on page 5. A condensate "p" trap must be installed for every unit as shown also on page 5.

LOCATION

Normally, the unit is installed outdoors either on the roof or ground, where practical. In normal roof installation, the unit is placed on an angle iron frame and isolated from the frame

with rubber, cork or spring mounts. These mounts are to help eliminate vibration and noise. Ground installation is basically the same for both self-contained units and split-system outdoor units. Locate the unit on a concrete slab or blocks not connected to the buildings foundation. Allow adequate clearance for service and air intake and discharge. The unit must be level in order to assure proper condensate drainage, and the gravity flow condensate line should be a minimum of 3/4 inch I.D. diameter and be properly graded.

The actual amount of total refrigerant charge for each installation may have to be adjusted to insure that unit performance characteristics (compressor electrical current draw, suction and discharge pressures) are consistent with those given in the application tables for the applicable ambient conditions.

It is extremely important that a condensate "P" trap be installed in the drain line below the bottom of the unit, as shown in the sketch below.

Apart from ensuring proper drainage, the

condensate trap will prevent the hot and humid outside air from being drawn into the conditioned space through the drain line, thus reducing cooling and dehumidification of the unit.

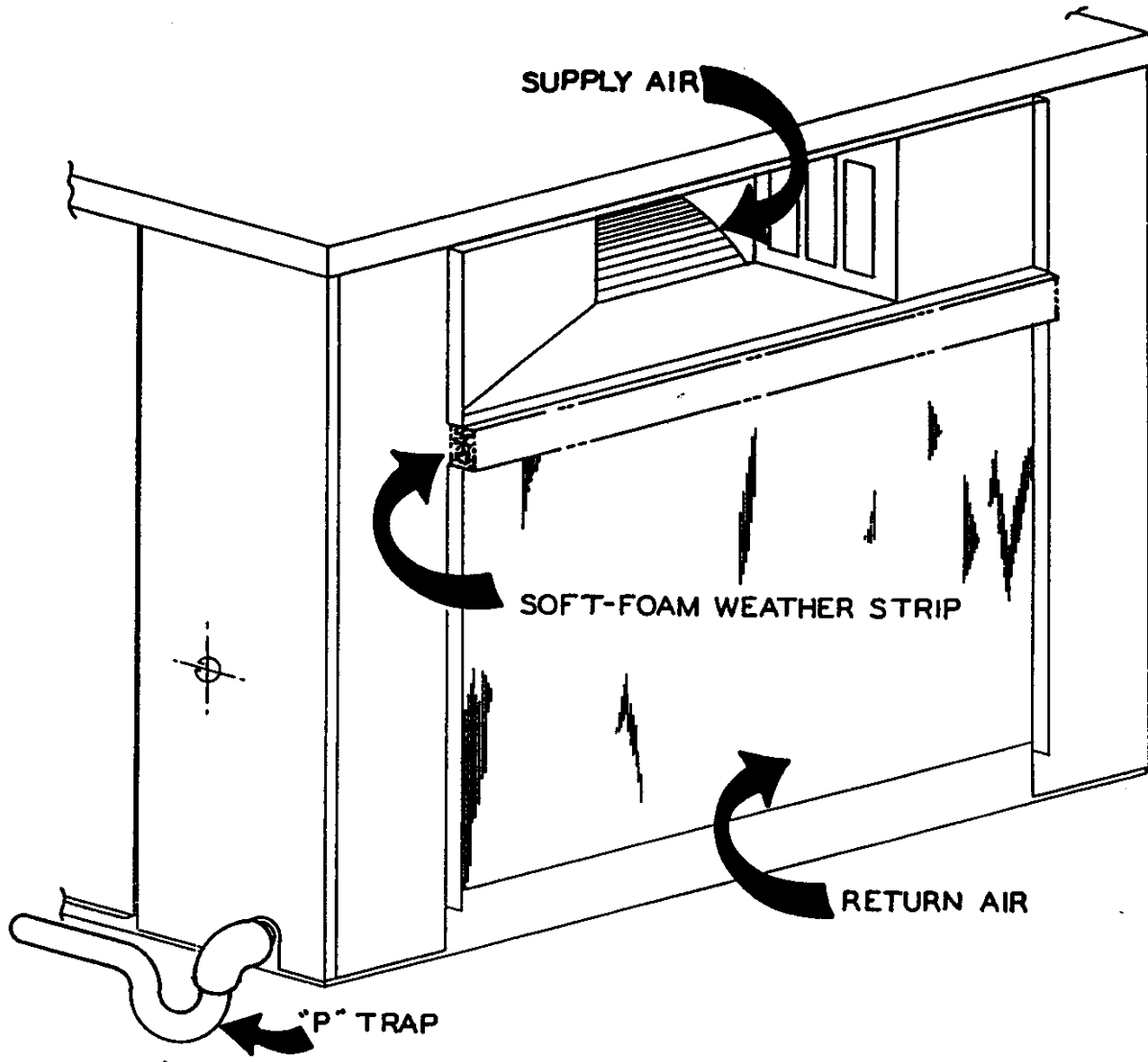

SYSTEM DRAIN TRAP

V. START-UP CHECK-OUT PROCEDURES

PRELIMINARY START-UP

1. If power to unit has been disconnected for any extended period of time, restore power twelve (12) hours prior to start-up procedure.

COOLING CYCLE CHECK-OUT PROCEDURE

1. With thermostat calling for cooling and set 10° below room temperature, engage disconnect switch(es) to start system.
2. Check the voltage at the compressor motor connections. If the voltage is 5% below or 10% above the rated voltage or there is a difference greater than 3% between phases, shut down the system and call the power company. A failure to do so may cause damage to the equipment.
3. After the unit is in operation, it will take about 30 minutes running time to stabilize the system.
4. In order to check for a properly working system, it is recommended that a thermometer be placed in the return air and one placed in the air supply. After all insulating of ductwork and adjustments of air registers are complete, a temperature difference of 15° to 20° is considered satisfactory.
5. When the above steps are completed, a check of voltage and amperage should be made of all motors. These readings should be within 10% of the performance ratings given for the specific ambients.
6. Suction and discharge pressures should also be checked to ensure that they agree reasonably well with the pressures shown in the catalog for the prevailing ambient conditions. Also, a suction superheat temperature of 20°F plus or minus 5°F is common for these units when the outdoor ambient is approximately 95°F. This should be used as a gauge in determining that the system is not overcharged or has lost some of its charge.
7. Finally, the thermostat should be checked out to assure proper operation. Literature packed with the thermostat and sub-base will provide information for this check out.

VI. ELECTRICAL OPERATION

With the disconnect on "ON" position, voltage is supplied to the primary of the control transformer and crankcase heater. The control transformer reduces the voltage from 230 or 208 to 24 volts for the low voltage and the thermostat circuit. With a single-stage cool/single-stage heat thermostat set in the cooling position, current is supplied from one side of the 24 volt secondary of the control transformer to the "R" terminal of the thermostat. The other side of this transformer connects to the main contractor coil through the high pressure con-

trol. When the thermostat calls for "COOLING", current from the "R" terminal is switched on to the "Y" terminal causing the compressor contactor to be energized. The main contactor closes the contacts in the high voltage circuit. The completion of this circuit will start both the outdoor fan motor and the compressor.

The indoor fan relay which is internally wired from "G" to "Y" in the thermostat sub-base is also energized and starts the indoor fan motor. The system will operate normally and begin to cool.

VII. RESISTANCE HEATERS

Resistance heaters are available as an optional field-installed accessory for air conditioners. Consult factory if resistance heaters

are needed, as a different thermostat or sub base may be required.

VIII. OPERATION AND MAINTENANCE

1. Be sure the filter is clean. Inspect every 30 days of operation; if obstructed, clean or replace filter at once. **DO NOT RUN WITHOUT A FILTER.**
2. Always let the thermostat control the operation of the system. Never try to "second guess" the thermostat, or tamper with it. Just set the thermostat at the comfort level desired **AND LEAVE IT ALONE.** If it gets too chilly, just turn the thermostat up a degree at a time until the desired level is achieved. Don't turn the thermostat back and forth.
3. Air conditioners cannot cool off a house as fast as a furnace heats it. It pulls the temperature down slowly. Therefore, do not turn on and expect immediate action. It may take a day or so to pull down a hot, moist house when the unit is first installed, especially after it has been "soaked" in 100-110° ambient for days.
4. Keep both the evaporator and condenser coil surfaces clean. Accumulation of dirt will restrict the air flow and reduce the performance of your unit.
5. Keep condensate drain lines clear and clean. All blower fan motors are factory lubricated and require no attention. The compressor is hermetically sealed, requiring no attention.
6. Your new air conditioner is mounted outdoors. It is good practice to treat it just as you would your automobile if it was exposed to the elements constantly; an occasional coat of wax will give added protection against the elements.
7. Your new air conditioner compressor is equipped with a Permanent Split Capacitor motor. Therefore, **ALWAYS WAIT AT LEAST THREE MINUTES AFTER SHUTTING UNIT OFF BEFORE TRYING TO RESTART.** If the unit is started before the refrigerant pressures have a chance to balance, the compressor motor may trip on its overload, or, in very rare cases, blow a fuse. Under any normal operation, this will not happen. It is most likely to happen if a thermostat is chattering, or if the unit is started too quickly. Do not be alarmed if this happens. Just let the pressures balance out and then start the unit.
8. It is a good practice when there is a power outage, especially during severe thunder storms, to switch off your unit at the thermostat until the electrical power has been permanently restored. This could prolong the life of your compressor.

IMPORTANT – READ CAREFULLY

9. Your new air conditioner contains a special compressor warming electrical circuit to keep the compressor warm during long off periods. Do not be alarmed if this creates a light "humming" sound while the unit is not running. The "hum" may or may not occur.

Whenever the power has been disconnected from the unit for longer than twelve hours, be sure to turn the power back on twelve hours before starting the unit. This will give the compressor warming circuit a chance to operate and protect the compressor from damage.

HOW TO GET THE MAXIMUM PLEASURE FROM YOUR AIR CONDITIONER

In order that you may fully enjoy the comfort your Air Conditioner can bring you, an understanding of the basic principles involved are outlined in the following paragraphs.

HEATING LOAD:

Any residential cooling system is the reverse of a heating system. Family living habits that help the heating system hurt the cooling system. The heat pump, furnace, or boiler delivers heat into the rooms and the heat that is created within the house from electric lights, cooking, the TV set, etc. helps to heat the rooms – therefore, that much less heat is required from the boiler, furnace, or heat pump.

Cooling is just the reverse. The cooling equipment removes heat and humidity. Any extra heat released into the rooms from these same sources will make the room air warmer and place an extra burden upon the equipment.

Let's take the heat caused by cooking. For example, four top burners of a gas range can produce more heat than a three horsepower air conditioner can remove. It is much more practical and economical to ventilate this concentrate heat and moisture load than it is to dispose of it through your air conditioner. Here is a general rule.

Whenever you plan to have your oven or range top burners on for more than few minutes during hot weather, close off the kitchen from the rest of the house, open a window or outside door, and turn on your kitchen ventilator.

You can also effectively reduce the load on your cooling system by keeping window shades, blinds, or drapes closed or by installing awnings or canopies.

There are days when the temperature is relatively high, yet it is comfortable because the air is dry. This is because the relative humidity is low. There are other days when the tempera-

ture is about the same but there is discomfort. This is because the humidity is high.

Indoors, the air should be both cool and relatively dry for comfort. Therefore, the cooling unit has been designed to remove both heat and moisture.

THERMOSTAT SETTING:

For cooling, a temperature of 75 to 78 degrees is preferred by most people. You may select a lower temperature setting if you wish and you will probably have that temperature a good portion of the time. But do not be disappointed and condemn the equipment if the temperature gets a few degrees warmer during hot weather. Set the thermostat at the temperature agreeable to the family and leave it there.

Do not be concerned if, in the evening, when the outside temperature drops below the inside temperature, your air conditioning system is still running. The entire structure of your house has been soaking up heat from the sun all day long. After the sun has set there is still a tremendous amount of heat in the walls, ceiling, roof, furnishings, etc., that must be disposed of before the air conditioner stops running. Outdoor temperatures can drop rapidly after sundown, while the house and its furnishings continue to give off heat for several hours.

INDOOR BLOWER OPERATION

To improve the efficiency of the unit, the blower is operated on a time delay. Depending on the outside ambient, the blower could delay starting up for 5 to 15 seconds even though the thermostat calls for cooling. When the thermostat is satisfied, the blower could keep on running for 1/2 to 1-1/2 minutes longer. Do not be alarmed if you do not hear the blower running immediately after the unit is switched on.

Your unit is an Air Conditioner. It is producing cooled air. The cooling which is accomplished by means of remote controls, is completely automatic, and requires no attention after setting to the comfort level you desire.

TYPICAL AIR CONDITIONING SYSTEM WITH RESISTANCE HEATERS

WARNING
DISCONNECT ALL POWER SOURCES
BEFORE SERVICING

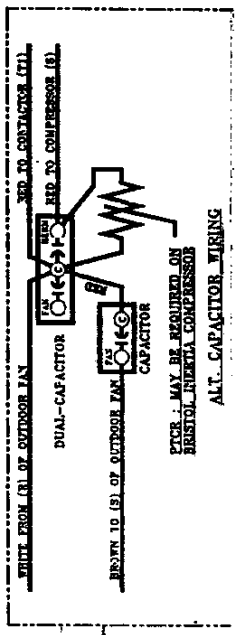
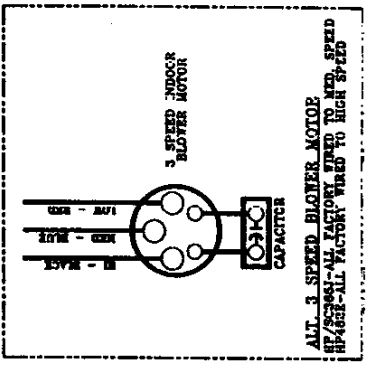
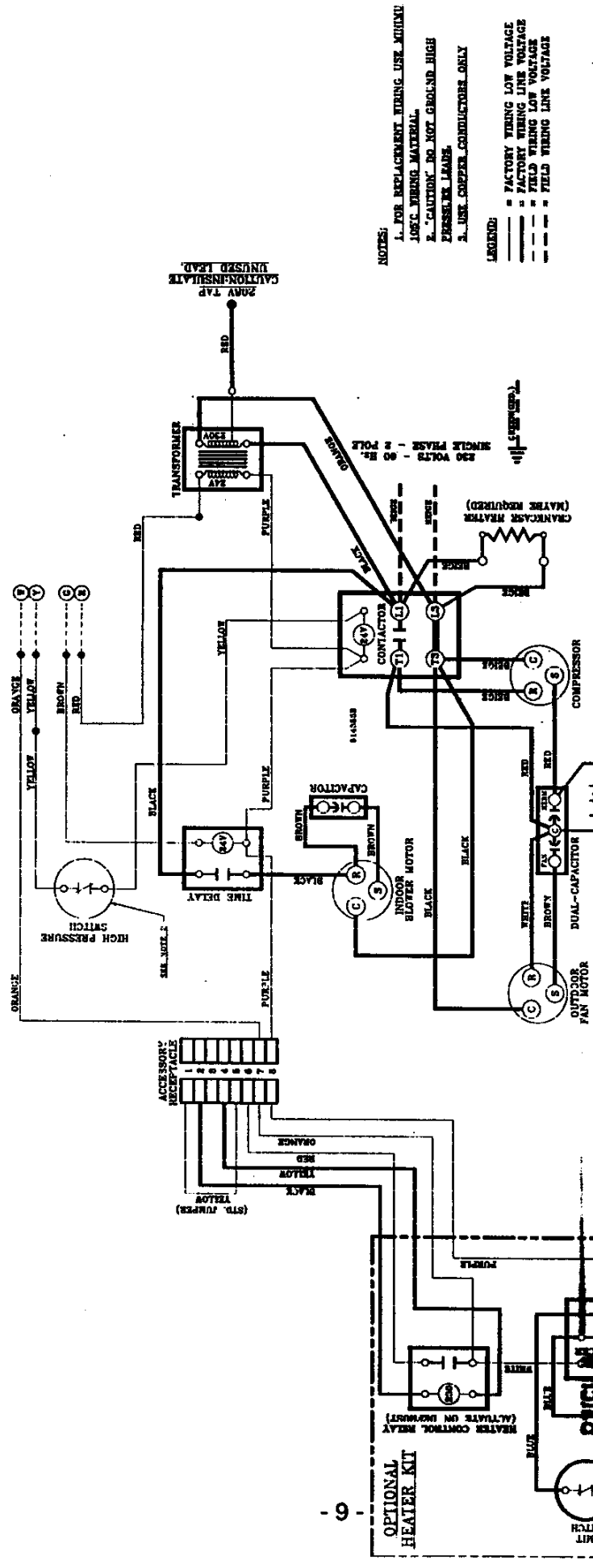

- NOTES:
1. FOR REPLACEMENT WIRING USE MINIMUM 100% WIRING MATERIAL.
 2. CAUTION DO NOT GROUND HIGH PRESSURE LEADS.
 3. USE COPPER CONDUCTORS ONLY.
- LEGEND:
- FACTORY WIRING LOW VOLTAGE
 - FACTORY WIRING LINE VOLTAGE
 - FIELD WIRING LOW VOLTAGE
 - FIELD WIRING LINE VOLTAGE

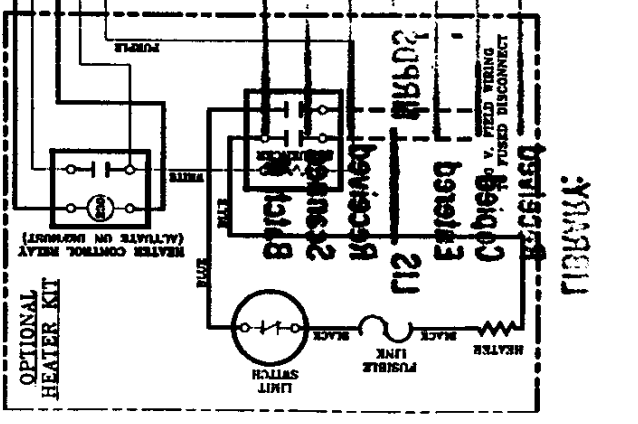

FIGURE 1

LIBRARY: 9/14/98 EDS.
 Received 9/14/98 EDS.
 Copied
 Entered
 LIS NRPS
 Received
 Scanned
 Batch #

GOETTL AIR CONDITIONING, INC.
 P.O. Box 52029 • Phoenix, Arizona 85072-2029

613360 Rev. 9/96 2.5M

