

## Installation, Start-Up and Service Instructions

### CONTENTS

	Page
<b>SAFETY CONSIDERATIONS</b> .....	1
<b>INSTALLATION</b> .....	1-6
<b>Step 1 — Complete Pre-Installation Checks</b> ..	1-4
• UNPACK UNIT	
• INSPECT SHIPMENT	
• CONSIDER SYSTEM REQUIREMENTS	
• CHECK ACCURATER® METERING DEVICE	
<b>Step 2 — Rig and Mount Unit</b> .....	4
• MOUNTING ON GROUND	
• MOUNTING ON ROOF	
• RIGGING	
<b>Step 3 — Complete Refrigerant Piping Connections</b> .....	4,5
• INSTALL FILTER DRIER AND MOISTURE INDICATOR	
• MAKE PIPING SWEAT CONNECTIONS	
• PROVIDE SAFETY RELIEF	
<b>Step 4 — Make Electrical Connections</b> .....	6
• POWER WIRING	
• CONTROL CIRCUIT WIRING	
<b>START-UP</b> .....	6,7
<b>Preliminary Checks</b> .....	6
<b>Leak Test</b> .....	6
<b>Evacuate and Dehydrate</b> .....	6
<b>Charge System</b> .....	6
<b>To Start Unit</b> .....	7
<b>SERVICE</b> .....	7-11
<b>MAINTENANCE</b> .....	11
<b>TROUBLESHOOTING</b> .....	12,13

### SAFETY CONSIDERATIONS

Installing and servicing air conditioning equipment can be hazardous due to system pressure and electrical components. Only trained and qualified service personnel should install or service air conditioning equipment.

Untrained personnel can perform basic maintenance, such as cleaning and replacing filters. All other operations should be performed by trained service personnel. When working on air conditioning equipment, observe safety precautions in literature, tags, and labels attached to unit.

Follow all safety codes. Wear safety glasses and work gloves. Use quenching cloth for brazing operations. Have fire extinguisher available. Read these instructions *thoroughly*. Consult local building codes and National Electrical Code (NEC) for special installation requirements.

### **⚠ WARNING**

Before installing or servicing system, always turn off main power to system. There may be more than one disconnect switch. Turn off accessory heater power if applicable. Electrical shock can cause personal injury.

### INSTALLATION

#### Step 1 — Complete Pre-Installation Checks

UNPACK UNIT (see Fig. 1.) — Move unit to final location. Remove carton from unit, being careful not to damage service valves and grilles.

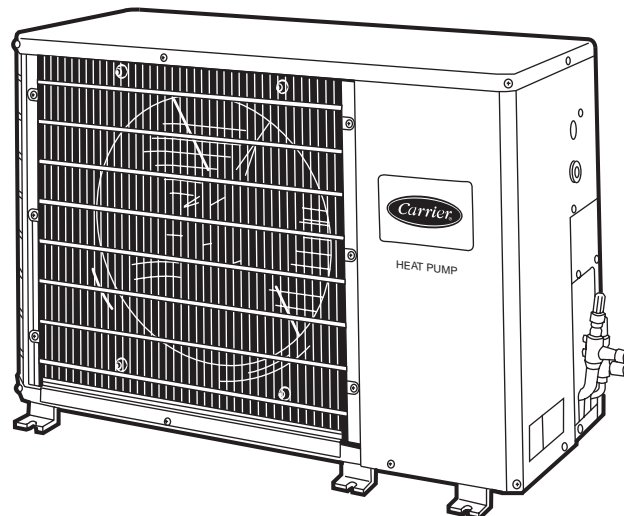

Fig. 1 — Model 38QR018C-060C

INSPECT SHIPMENT — File claim with shipping company if shipment is damaged or incomplete.

CONSIDER SYSTEM REQUIREMENTS — Consult local building codes and NEC for special installation requirements.

Allow sufficient space for airflow clearance, wiring, refrigerant piping, and servicing unit. See Fig. 2 and 3.

Locate unit so that airflow is unrestricted on both sides. Refer to Fig. 2 and 3.

Unit may be mounted on a level pad directly on base legs or mounted on raised pads at support points. See Fig. 2 and 3 for center of gravity.

CLICK ANYWHERE ON THIS PAGE TO RETURN TO CARRIER AIR CONDITIONERS BOILERS FURNACES AGE MANUALS at [InspectApedia.com](http://InspectApedia.com)

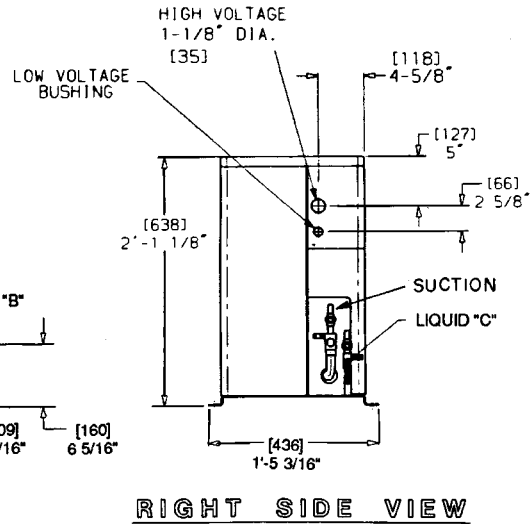
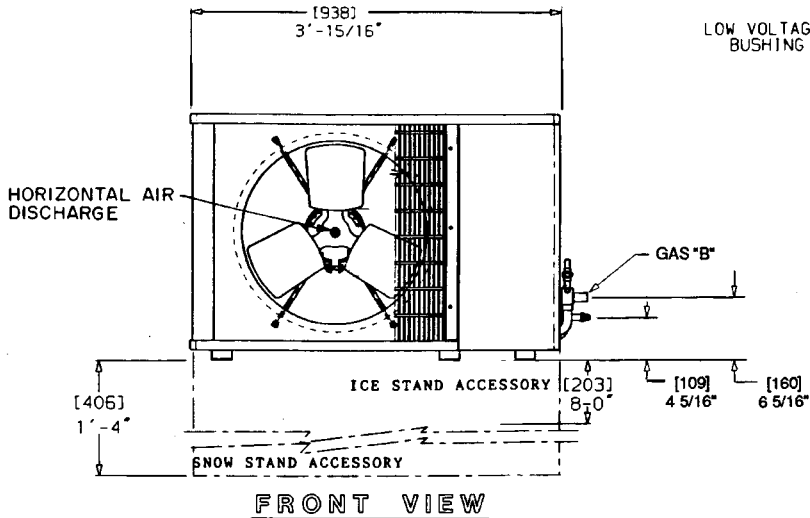
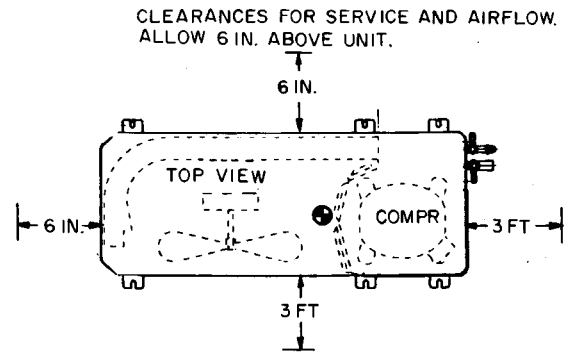
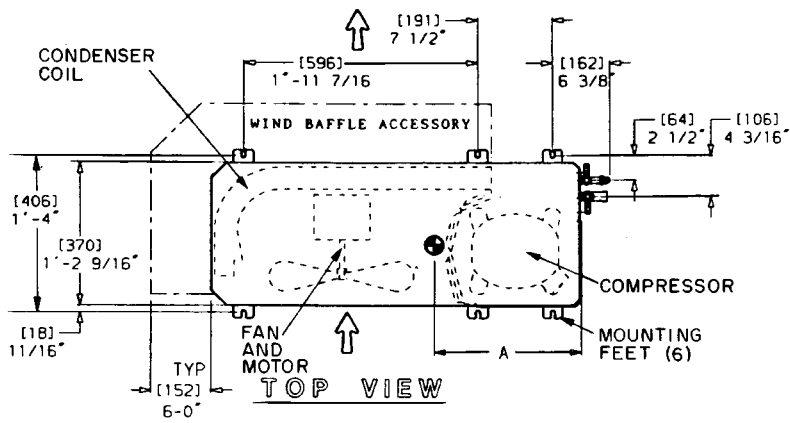

NOTES:

1. Dimensions in [ ] are in millimeters.

2. Airflow →

3. Center of gravity ●

4. Footprint 018C-036C: 3.7 sq ft (.34 m<sup>2</sup>).

5. Do not use screws longer than 1/2 in. (13 mm) near return-air opening.

UNIT	WEIGHT — LB (KG)	DIMENSIONS — in. (mm)		
		"A"	"B"	"C"
38QR018C	154 (70)	13 (329)	5/8 (15.88)	3/8 (9.53)
38QR024C	167 (76)			
38QR030C	180 (82)		3/4 (19.05)	
38QR036C	184 (83)			

Fig. 2 — 38QR Dimensional Drawing, 018C-036C (Single-Phase Units)

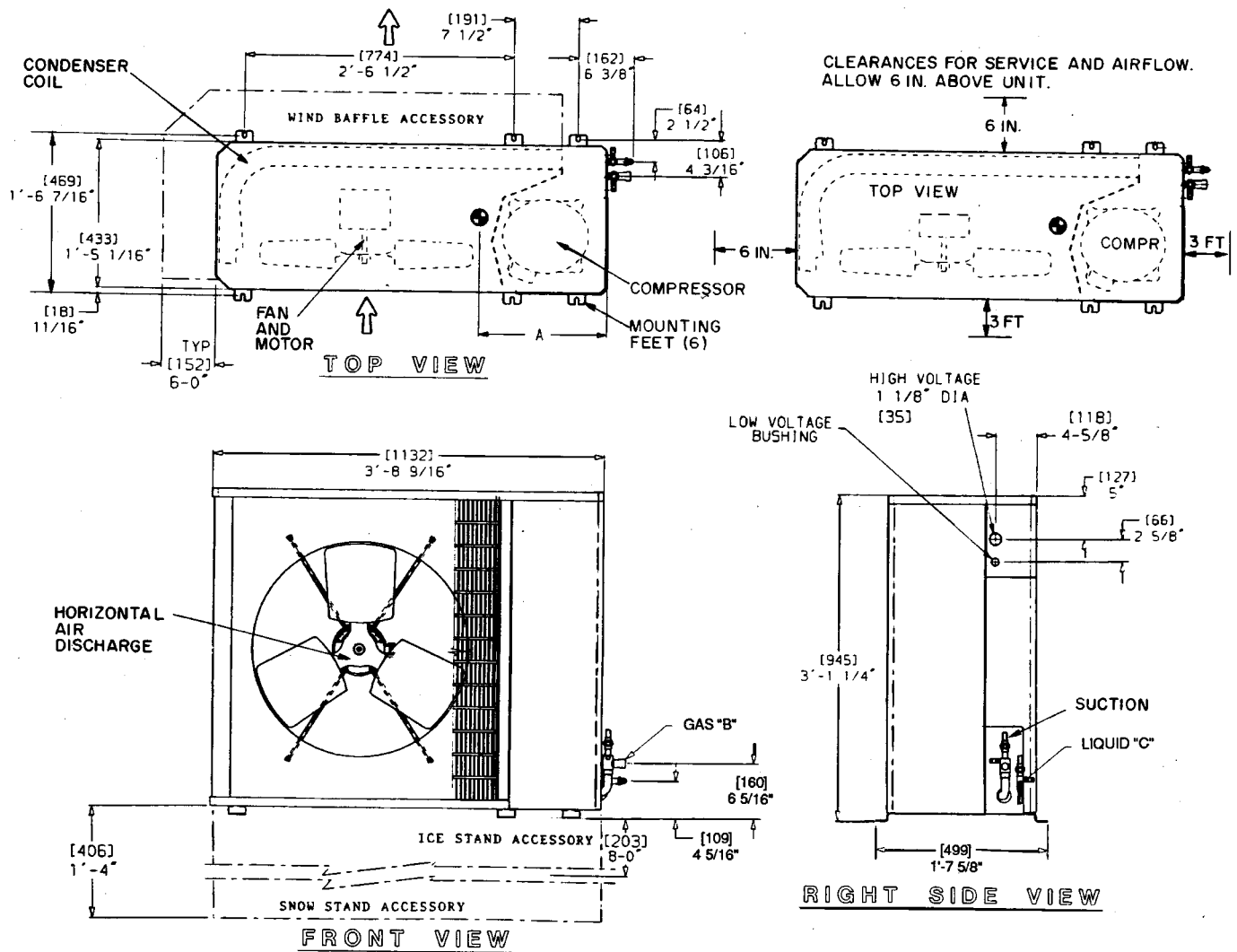

- NOTES:
1. Dimensions in [ ] are in millimeters.
  2. Airflow .
  3. Center of gravity .
  4. Footprint 048C,060C: 5.3 sq ft (.49 m<sup>2</sup>).
  5. Do not use screws longer than 1/2 in. (13 mm) near return-air opening.

UNIT	WEIGHT — LB (KG)	DIMENSIONS — in. (mm)		
		"A"	"B"	"C"
38QR036C	249 (113)	13 11/16 (28.97)	7/8 (22.22)	3/8 (9.53)
38QR048C	252 (114)	13 11/16 (28.97)	7/8 (22.22)	3/8 (9.53)
38QR060C	272 (123)	14 1/2 (30.69)	7/8 (22.22)	3/8 (9.53)

Fig. 3 — 38QR Dimensional Drawing, 036C (3-Phase Units) and 048C,060C (Single- and 3-Phase Units)

**CHECK ACCURATER® METERING DEVICE** — The correct AccuRater (bypass type) refrigerant control is required for system capacity optimization. An AccuRater device with field-replaceable piston (see Fig. 4) is supplied on indoor coil and at service valve of outdoor unit. Refer to the AccuRater metering device table in separate indoor unit installation instructions to determine the correct AccuRater piston size required for the heat pump/indoor unit system being installed.

Note that one of 2 types of AccuRater controls can be found on the indoor unit, and that Type B AccuRater devices are used on 38QR018C-060C heat pumps. *Do not* interchange components between the AccuRater device types. Matching of heat pump with indoor unit may require field replacement of piston. Replace pistons, *if required*, before connecting refrigerant lines. Piston replacement instructions are included in separate indoor unit installation instructions. After system installation is complete, see Refrigerant Charging section on page 10 to check and/or adjust refrigerant charge.

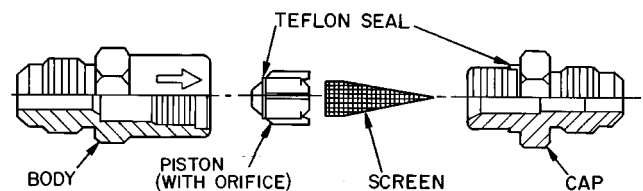
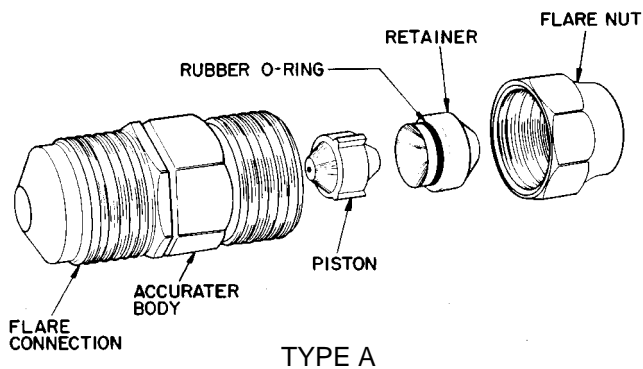

NOTE: Arrow on AccuRater body points in *free flow* direction, away from the indoor coil.

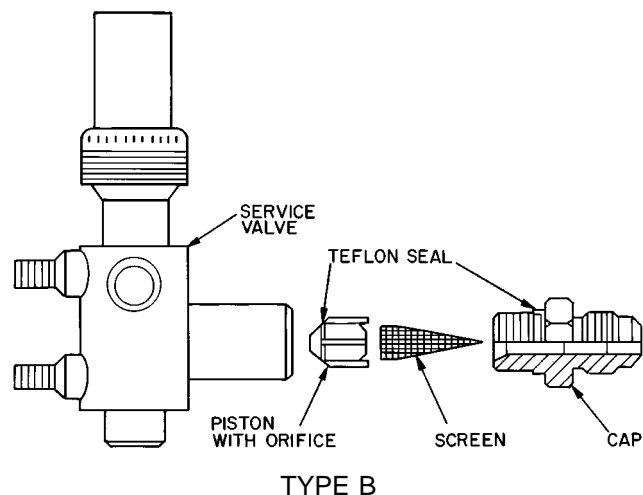

**Fig. 4 — AccuRater® (Bypass Type) Metering Device Components**

## Step 2 — Rig and Mount Unit

**MOUNTING ON GROUND** — Mount unit on a solid, level concrete pad. Position unit so water or ice from roof does not fall directly onto unit. Use accessory snow rack (part no. 38QR900001 or -011) or ice stand (part no. 38QR900021 or -031) (see Fig. 2, 3) where prolonged subfreezing temperatures or heavy snow occurs. Refer to separate installation instructions packaged with the accessories. If conditions or local codes require unit be fastened to pad, 6 field-supplied tiedown bolts should be used and fastened through slots provided in unit mounting feet.

**MOUNTING ON ROOF** — Mount unit on a level platform or frame at least 6 in. above roof surface. Isolate unit and tubing from structure.

### RIGGING

#### ⚠ CAUTION

Be sure unit panels are securely in place prior to rigging.

Keep unit upright. Lift unit using sling. Use cardboard or padding under sling, and spreader bars to prevent sling damage to unit. See Fig. 5. See Fig. 2 and 3 for center of gravity reference. Install unit so that coil does not face into prevailing winds. If this is not possible and constant winds above 25 mph are expected, use Accessory Wind Baffle (part no. 38QR900041 or -051). See installation instructions provided with accessory kit.

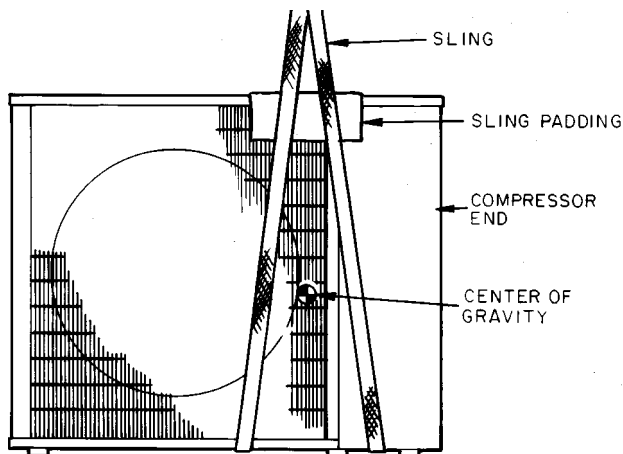

**Fig. 5 — Lifting Unit With Sling**

## Step 3 — Complete Refrigerant Piping Connections

Outdoor units may be connected to indoor units using field-supplied tubing of refrigerant grade and condition. See Table 1 for correct line sizes. Do not use less than 10 ft of interconnecting tubing.

#### ⚠ CAUTION

**DO NOT BURY MORE THAN 36 IN. OF REFRIGERANT PIPE IN THE GROUND.** If any section of pipe is buried, there must be a 6-in. vertical rise to the valve connections on the outdoor unit. If more than the recommended length is buried, refrigerant may migrate to cooler, buried section during extended periods of system shutdown. This causes refrigerant slugging and could possibly damage compressor at start-up.

When more than 50 ft of interconnecting tubing and more than 30 ft of vertical lift is used, refer to Part 3 of Carrier System Design Manual for design details, or contact your local distributor.

If either refrigerant tubing or indoor coil is exposed to atmospheric conditions for longer than 5 minutes, it must be evacuated to 1000 microns to eliminate contamination and moisture in the system.

Run refrigerant tubes as directly as possible, avoiding unnecessary turns and bends. Suspend refrigerant tubes so they do not damage insulation on vapor tube and do not transmit vibration to structure. Also, when passing refrigerant tubes through wall, seal opening so that vibration is not transmitted to structure. Leave some slack in refrigerant tubes between structure and outdoor unit to absorb vibration. Refer to separate indoor unit installation instructions for additional information.

**INSTALL FILTER DRIER AND MOISTURE INDICATOR** — The filter drier is factory supplied and field installed. Moisture indicator (sight glass) is a field-supplied option and should be installed just after liquid line shutoff valve. *Do not use a receiver* (a receiver is not provided with unit and one should not be used).

**MAKE PIPING SWEAT CONNECTIONS** — Remove plastic caps from liquid and suction service valves. Use refrigerant grade tubing. Service valves are closed from the factory and are ready for brazing. After wrapping the service valve with a wet cloth, the tubing set can be brazed to the service valve using either silver bearing or non-silver bearing brazing material. Consult local code requirements. Refrigerant tubing and indoor coil are now ready for leak testing.

**NOTE:** Unit is shipped with R-22 factory holding charge indicated on nameplate.

Pass nitrogen or other inert gas through piping while brazing to prevent formation of copper oxide.

**⚠ CAUTION**

To avoid damage while brazing, service valves should be wrapped with a heat-sinking material such as a wet cloth.

**⚠ CAUTION**

When brazing tubing sets to the service valves, a brazing shield **MUST** be used to prevent damage to the painted unit surface.

**PROVIDE SAFETY RELIEF** — A fusible plug is located in unit suction line; do not cap this plug. If local code requires additional safety devices, install as directed.

**Table 1 — Physical Data**

Unit 38QR	018C-3	024C-3	030C-3	036C-3	036C-5,6	048C-3,5,6	060C-3,5,6
Operating Weight (lb)	154	167	180	184	249	252	272
Refrigerant	R-22						
Compressor Type	Reciprocating		Scroll		Reciprocating		
Model	Tecumseh AW5519G	Tecumseh AW5524G	Copeland ZR28KI-PFV	Copeland ZR34KI-PFV	Copeland CRH3-0275	Tecumseh AV5549G	Copeland CRP5-0450
Oil (pt) — Initial/Recharge	32/30	32/30	28/24	34/30	55/51	54/50	70/66
Crankcase Heater Watts	19	19	—	—	40	27	40
Outdoor Fan Rpm	Propeller Type, Direct Drive, Horizontal						
Diameter (in)-no. of Blades	850	850	850	850	850	850	850
Fan Pitch (Deg)	18-3	18-3	18-3	18-3	24-3	24-3	24-3
Motor Hp	25	27	27	31	24	24	24
Nominal Airflow (cfm)	1/8	1/8	1/8	1/8	1/4	1/4	1/4
Outdoor Coil Face Area (Sq Ft)/Rows	1720	1720	1720	1720	3900	3900	3900
Fins./in.	Copper Tube, Aluminum Plate Fin						
Line Sizes† — (in. OD)	6.1/1.5*	6.1/2	6.1/3	6.1/3	12.3/2	12.3/2	12.3/3
Vapor	15	15	15	15	15	15	15
Liquid	5/8	5/8	3/4	3/4	3/4	1 1/8	1 1/8
Valve Connection — ODF (in.)	3/8	3/8	3/8	3/8	3/8	3/8	3/8
Vapor	5/8	5/8	3/4	3/4	7/8	7/8	7/8
Liquid	3/8	3/8	3/8	3/8	3/8	3/8	3/8
Controls — Pressurestat Settings							
High Cutout (psig)	426 ± 7						
High Cut-in (psig)	320 ± 20						
Low Cutout (psig)	7 ± 3						
Low Cut-in (psig)	22 ± 5						
Fusible Plug	210 F						

\*The second row of the coil is one half of the height of the first row.

†Line sizes are for runs up to 25 ft.

## Step 4 — Make Electrical Connections

### ⚠ WARNING

Unit cabinet must have an uninterrupted, unbroken electrical ground to minimize the possibility of personal injury if an electrical fault should occur. This ground may consist of electrical wire connected to unit ground lug in control compartment, or conduit approved for electrical ground when installed in accordance with NEC, ANSI/NFPA (American National Standards Institute/National Fire Protection Association) 70-1987 and local electrical codes. Failure to follow this warning could result in the installer being liable for personal injury of others.

### ⚠ CAUTION

Unit failure as a result of operation on improper line voltage or excessive phase imbalance constitutes abuse and may cause damage to electrical components. Such operation would invalidate any applicable Carrier warranty.

**POWER WIRING** — Unit is factory wired for voltage shown on nameplate. Provide adequate fused disconnect switch within sight from unit, readily accessible, but out of reach of children. Provision for locking switch open (off) is advisable to prevent power from being turned on while unit is being serviced. Disconnect switch, fuses, and field wiring must comply with NEC and local code requirements. Use copper wire only between disconnect switch and unit. Use minimum 60 C wire for field power connection.

Route power wires through opening in unit side panel and connect in unit control box as shown on unit label diagram and Fig. 6 and 7. Unit must be grounded.

**CONTROL CIRCUIT WIRING** — Control voltage is 24 v (40 va minimum). See Fig. 7 and unit label diagram for field-supplied wiring details. Route control wires through opening in unit side panel to connection in unit control box.

**NOTE:** For wire runs up to 50 ft, use no. 18 AWG (American Wire Gage) insulated wire (35 C minimum) For 50 to 75 ft, use no. 16 AWG insulated wire (35 C minimum). For over 75 ft, use 14 AWG insulated wire (35 C minimum).

**NOTE:** Operation of unit on improper line voltage constitutes abuse and could affect Carrier warranty. See Table 2. Do not install unit in system where voltage may fluctuate above or below permissible limits.

See Table 2 for recommended fuse sizes. When making electrical connections, provide clearance at unit for refrigerant piping connections.

Use indoor unit transformer as 24-v (40-v minimum) supply for system or use accessory transformer.

### ⚠ WARNING

Before performing service or maintenance, be sure indoor unit main power switch is turned OFF and indoor blower has stopped. Failure to do so may result in electrical shock, or injury from rotating fan blades.

## START-UP

### Preliminary Checks

1. Check that all internal wiring connections are tight and that all barriers, covers, and panels are in place.
2. Field electrical power source must agree with unit nameplate rating.

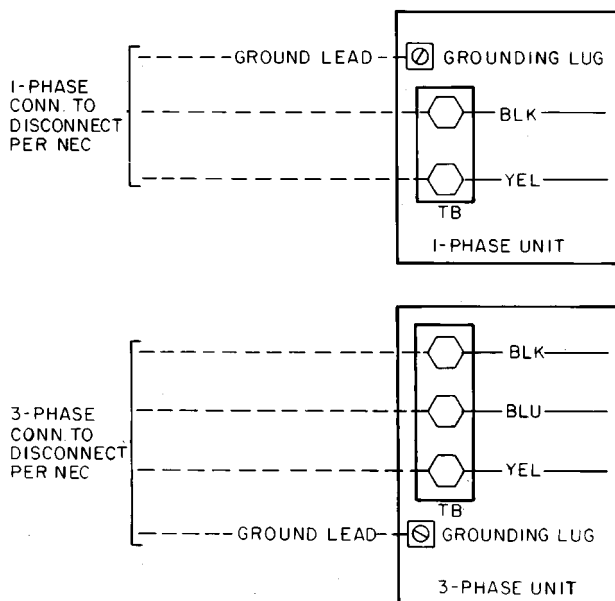

### LEGEND

- NEC — National Electrical Code  
 TB — Terminal Board  
 ○ — TB Connections  
 - - - - Field Wiring  
 \_\_\_\_\_ Factory Wiring

Fig. 6 — Line Power Connections

3. All service valves must be open.
4. Belly-band crankcase heater must be tight on compressor crankcase for those units with belly-band heaters.

**Leak Test** — Field piping and fan coil must be leak tested by pressure method described in Carrier Standard Service Techniques Manual, Chapter 1, Section 1-6. Use R-22 at approximately 25 psig backed up with an inert gas to a total pressure not to exceed 245 psig.

Before starting unit, crankcase heater must be on for 12 hours to be sure all refrigerant is out of the oil.

To energize crankcase heater, set space thermostat above ambient temperature so there will be no demand for cooling. Close field disconnect. The crankcase heater is now energized.

**Evacuate and Dehydrate** — Field piping and fan coil must be evacuated and dehydrated by either of the methods described in Carrier Standard Service Techniques Manual, Chapter 1, Section 1-7.

### ⚠ WARNING

Service valves must be fully backseated to close service port. There is no Schrader valve at the service port, and failure to backseat the valve could result in loss of system charge or personal injury.

**Charge System** — Release holding charge into system by opening (backseating) liquid and suction line service valves. Add charge amount as required for the total system. Refer to indoor unit installation instructions for the required total system charge, when connected by 25 ft of tubing.

**SYSTEMS WITHOUT OUTDOOR THERMOSTATS**

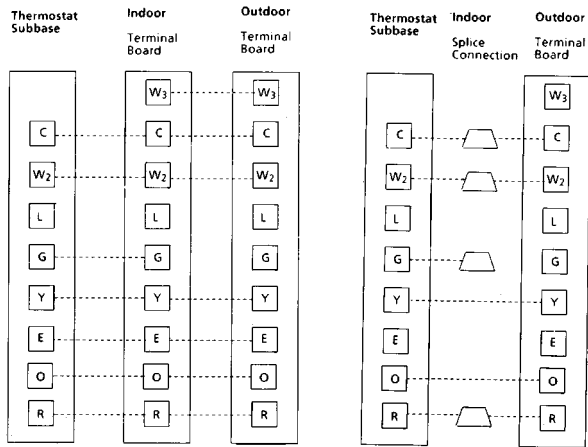

USED WITH UNITS 40AQ, 40QB/QH, FD3A, FB4A, FB5A, FK4A, 40DQ AND 40YA/YR/YZ

USED WITH UNITS FF1A AND 40RC

**SYSTEMS WITH ONE OUTDOOR THERMOSTAT**

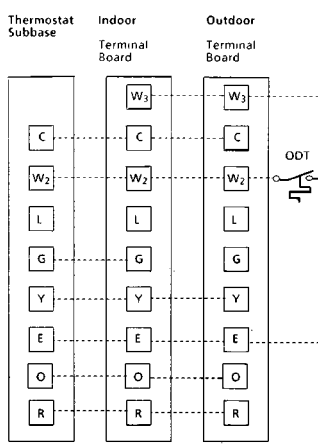

USED WITH UNITS FF1A AND 40RC

**SYSTEMS WITH TWO OUTDOOR THERMOSTATS**

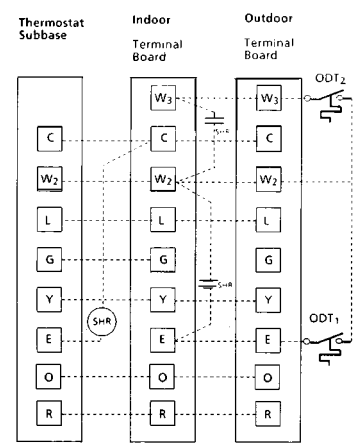

USED WITH UNITS 40AQ, 40QB/QH, FD3A, FB4A, FK4A, FB5A, 40DQ, AND 40YA/YR/YZ

NOTE: Remove factory-installed jumpers on indoor unit terminal board when installing outdoor thermostats.

- LEGEND**
- ODT — Outdoor Thermostat
  - SHR — Supplemental Heat Relay
  - Splice Connection
  - Factory Wiring
  - Field Wiring

**Fig. 7 — Typical Control Circuit Connections**

**To Start Unit** — Be sure that crankcase heater has been on for 12 hours and that field disconnect is closed. Set room thermostat below ambient temperature. Operate unit for 15 minutes, then check system refrigerant charge. See Refrigerant Charging section on page 10.

Unit compressor starts after a 5-minute delay if equipped with accessory Time Guard® II device (part no. 38HD900021). See separate accessory installation instructions to install this accessory. When ambient temperature will fall below 55 F, accessory low-ambient controller (part no. 38HD900001) is required.

**SERVICE**

**⚠ WARNING**

Before performing recommended maintenance, be sure unit main power switch is turned off. Failure to do so may result in electrical shock or injury from rotating fan blade.

**Outdoor Fan** — A reinforced wire mount holds the outdoor-fan motor assembly in position. See Fig. 8 for proper mounting positions.

**High-Pressure Relief Valve** — Valve is located in compressor. Relief valve opens at a pressure differential of approximately 450 ± 50 psig between suction (low side) and discharge (high side) to allow pressure equalization.

**Internal Current and Temperature Sensitive Overload** — Control resets automatically when internal compressor motor temperature drops to a safe level (overloads may require up to 45 minutes to reset). When an internal overload is suspected of being open, check by using an ohmmeter or continuity tester. If necessary, refer to Carrier Standard System Techniques Manual, Chapter 2, for complete information.

**Pumpdown Procedure** — The system may be pumped

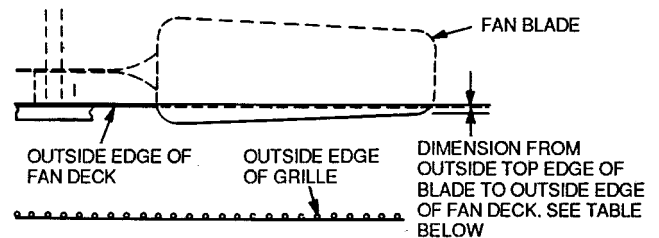

UNIT SIZE-in. (mm)		
38QR018C	38QR024C,030C,036C	38QR048C,060C
.433 (11)	.709 (18)	.16 (4)

**Fig. 8 — Outdoor Fan Mounting Positions**

down in order to make repairs on low side without losing complete refrigerant charge.

1. Attach pressure gage to suction service valve gage port.
2. Frontseat the liquid line valve.

**⚠ CAUTION**

The 38QR018C-060C unit coils hold only the factory-designated amount of refrigerant. Additional refrigerant may cause units to relieve pressure through compressor internal pressure relief valve (indicated by a sudden rise of suction pressure) before suction pressure reaches 5 psig. If this occurs, shut off unit immediately, frontseat suction valve, and remove and reclaim excess refrigerant following accepted practices.

3. Start unit and run until suction pressure reaches 5 psig or low-pressure switch opens.
4. Shut off unit and frontseat suction valve.
5. Depressurize low side of unit and reclaim refrigerant following accepted practices.

**Table 2 — Electrical Data**

OUTDOOR UNIT 38QR	V-PH-HZ	OPERATIONAL VOLTAGE*		COMPR		FAN FLA	MCA	MAX FUSE† OR HACR TYPE CKT BKR AMPS
		Max	Min	LRA	RLA			
018C	208/230-1-60	253	187	49.0	8.9	.70	11.8	20
024C				61.0	10.9	.70	14.3	25
030C				76.0	13.5	.70	17.6	30
036C				90.5	17.9	.70	23.1	40
048C				110.0	22.4	1.45	29.5	50
060C				135.0	27.6	1.50	36.0	60
036C	208/230-3-60	253	187	66.0	11.2	1.45	15.5	20
048C				92.0	14.7	1.45	19.8	40
060C				105.0	17.7	1.50	23.6	45
036C	460-3-60	506	414	35.0	5.8	.80	8.1	15
048C				46.0	6.7	.80	9.2	15
060C				55.0	10.4	.83	13.8	20

**LEGEND**

- FLA** — Full Load Amps
- HACR** — Heating, Air Conditioning, Refrigeration
- LRA** — Locked Rotor Amps
- MCA** — Minimum Circuit Amps per NEC Section 430-24
- NEC** — National Electrical Code
- RLA** — Rated Load Amps (Compressor)

\*Permissible limits of the voltage range at which unit will operate satisfactorily.

†Time-delay fuse.

**NOTES:**

1. Control circuit is 24 v on all units and requires an external power source.
2. All motors and compressors contain internal overload protection.
3. In compliance with NEC requirements for multimotor and combination load equipment (refer to NEC Articles 430 and 440), the overcurrent protective device for the unit shall be fuse or HACR breaker.
4. **Unbalanced 3-Phase Supply Voltage**  
Never operate a motor where a phase imbalance in supply voltage is greater than 2%. Use the following formula to determine the % voltage imbalance.

% Voltage Imbalance

$$= 100 \times \frac{\text{max voltage deviation from average voltage}}{\text{average voltage}}$$

Example: Supply voltage is 460-3-60.

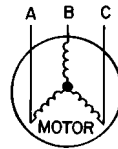

- AB = 452 v
- BC = 464 v
- AC = 455 v

$$\begin{aligned} \text{Average Voltage} &= \frac{452 + 464 + 455}{3} \\ &= \frac{1371}{3} = 457 \end{aligned}$$

Determine maximum deviation from average voltage.

- (AB) 457 - 452 = 5 v
- (BC) 464 - 457 = 7 v
- (AC) 457 - 455 = 2 v

Maximum deviation is 7 v.

Determine % voltage imbalance.

$$\% \text{ Voltage Imbalance} = 100 \times \frac{7}{457} = 1.53\%$$

This amount of phase imbalance is satisfactory as it is below the maximum allowable 2%.

**IMPORTANT:** If the supply voltage phase imbalance is more than 2%, contact your local electric utility company immediately.



**Filter Drier** — Whenever the moisture liquid indicator shows presence of moisture, replace the filter drier. Refer to Carrier Standard Service Techniques Manual, Chapter 1, Refrigerants, for details on servicing filter driers.

**High-Pressure Switch** — This switch, located on discharge line, protects against high discharge pressures caused by such events as overcharge, outdoor-fan motor failure, system restriction, etc. It opens on pressure rise at about 426 psi. If system pressures go above this setting during abnormal conditions, the switch opens.

**⚠ WARNING**

DO NOT attempt to simulate the system abnormalities — high pressures pose a serious safety hazard.

High-pressure switch is also checked with an ohmmeter similar to checking low-pressure switch. If system pressure is below 426 psi, switch shows continuity.

**Low-Pressure Switch** — This switch, mounted on the suction line, has fixed, non-adjustable settings. The switch is bypassed during defrost, and also for the first 2 minutes of heating operation after defrost, by means of a time-delay

relay. This prevents nuisance tripping of the low-pressure switch.

To check pressure switch, attach pressure gage to suction service valve gage port. Slowly close liquid shutoff valve and allow compressor to pump down. Do not allow compressor to pump down below 2 psig. Compressor should shut down when suction pressure drops to cutout pressure in Table 1, and should restart when pressure builds up to cut-in pressure shown after CLO (compressor lockout switch) has been reset and accessory Time Guard® device has completed its timing cycle.

**Crankcase Heater** — Heater prevents refrigerant migration and compressor oil dilution during shutdown when compressor is not operating. If crankcase heater is deenergized for more than 6 hours, both compressor service valves must be closed.

Crankcase heaters come in 2 basic types: wraparound (bellyband) type that is wrapped externally around compressor shell, and insertion type that is inserted into compressor oil well in shell of compressor.

Crankcase heater is powered by *high-voltage* power of unit. It is connected across the line side of the contactor and operates continually. Use extreme caution when troubleshooting this device with power on.



To troubleshoot:

1. Apply voltmeter across crankcase heater leads to see if heater voltage is on. *Do not touch heater.* Carefully feel area around crankcase heater; if warm, crankcase heater is probably functioning.
2. With power off and heater leads disconnected, check across leads with ohmmeter. Do not look for a specific resistance reading. Check for resistance or an open circuit, and change heater if an open circuit is detected.

**Service Valves** — The service valves in the outdoor unit come from the factory frontseated. This means the refrigerant charge is isolated from the line set connection ports. To prevent damage to the valve, use a wet cloth or other accepted heat sink material on the valve before brazing.

The service valves must be backseated (turned counter-clockwise until seated) before the service port caps can be removed and the hoses of gage manifold connected. In this position, refrigerant has access from and through outdoor and indoor unit. The service valve cannot be field repaired, therefore, only a complete valve or valve stem seal and service port caps are available for replacement.

**AccuRater® Control (Bypass Type)** — See Fig. 4 for bypass-type AccuRater device components. The piston has a refrigerant metering hole through it. The retainer forms a stop for the piston in the refrigerant bypass mode, and a sealing surface for liquid line flare connection. To check, clean or replace piston:

1. Shut off power to unit.
2. Pump down unit using Pumpdown Procedure section on page 7.
3. Remove liquid line flare connection from the AccuRater device.
4. Pull retainer out of body, being careful not to scratch flare sealing surface. If retainer does not pull out easily, carefully use locking pliers to remove retainer.
5. Slide piston out by inserting a small, soft wire, with small kinks, through metering hole. Ensure metering hole, sealing surface around piston cones, and fluted portion of piston are not damaged.
6. Clean piston refrigerant metering hole.
7. Replace retainer O-ring before reassembling AccuRater control (Carrier O-ring part no. 99CC501052).

**Defrost Control** — The control, which consists of defrost control board and defrost thermostat, interrupts the normal system heating operation to defrost the outdoor coil, *if the coil saturated suction temperature indicates freezing temperatures.*

Defrost control board can be field set to check need for defrost every 30, 50, or 90 minutes of operating time, by connecting the jumper (labeled W1, on the circuit board) to the spade terminal for the defrost time desired. The board is factory set for 90 minutes. The defrost period is field selectable, depending upon geographic areas and defrost demands. Control board has additional feature that allows unit to restart in defrost cycle if room thermostat is satisfied during defrost.

Defrost control simultaneously tops outdoor fan, energizes reversing valve solenoid to return system to cooling cycle (outdoor unit as condenser, indoor unit as evaporator), and activates accessory electric heater.

The defrost timer limits defrosting period to 10 minutes. Normally, the frost is removed and the defrost thermostat contacts open to terminate defrosting before 10 minutes have elapsed.

When defrosting is terminated, the outdoor-fan motor is energized, and reversing valve solenoid is deenergized, returning unit to heating cycle.

**Reversing Valve** — In heat pumps, changeover between heating and cooling modes is accomplished with a valve that reverses flow of refrigerant in system. The reversing valve solenoid can be checked with power off using an ohmmeter. Check for continuity and shorting to ground. With control circuit (24v) power on, check for correct voltage at solenoid coil, and for burned or overheated solenoid.

With unit operating, other items can be checked, such as frost or condensate on refrigerant lines.

Using a remote measuring device, check inlet and outlet line temperatures. *Do not touch lines.* If reversing valve is operating normally, inlet and outlet temperatures on appropriate lines should be similar. Any temperature difference would be due to heat loss or gain across valve body. Temperatures are best checked with a remote reading electronic-type thermometer with multiple probes.

Figures 9 and 10 show test points on reversing valve for recording temperatures. Insulate points for more accurate reading. If valve is defective:

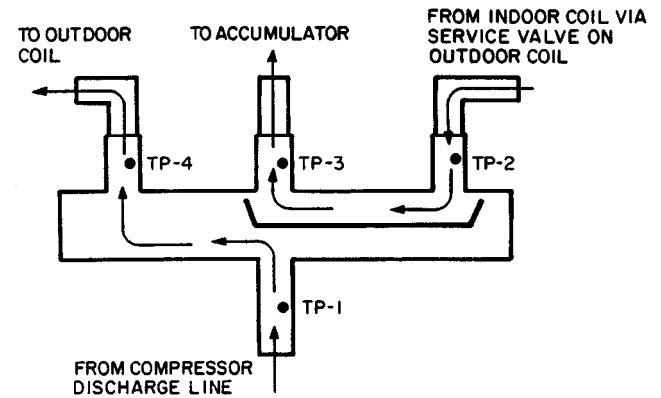

LEGEND  
TP — Test Point

**Fig. 9 — Reversing Valve (Cooling Mode or Defrost Mode, Solenoid Energized)**

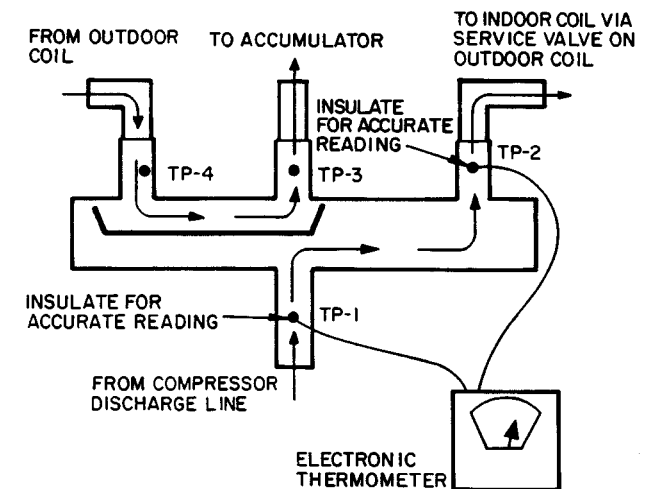

LEGEND  
TP — Test Point

**Fig. 10 — Reversing Valve (Heating Mode, Solenoid Deenergized)**

1. Shut off all power to unit.
2. Remove all charge from system.
3. Remove valve using a tubing cutter.
4. Install new valve (wrap valve with a wet rag to prevent overheating while brazing).
5. After valve is brazed in, check for leaks.
6. Evacuate and charge system. Operate system in both modes several times to be sure valve functions properly.

**Discharge Temperature Switch (DTS)** — Switch, used only on unit sizes 030 and 036 with scroll compressors, senses high discharge temperature levels reached under extreme operating conditions (low charge or low evaporator airflow). Approximate cut-in and cutout temperatures are 290 F and 140 F, respectively.

**Thermistors** — The outdoor coil temperature thermistor and outdoor air temperature thermistor are used only with duct-free split systems that use a microprocessor control. Refer to separate installation instructions for models 40QA and 40QY indoor units.

**Time-Delay Relay (TDR1)** — Relay, used only on unit sizes 030 and 036 with scroll compressors, ensures that compressor comes to complete stop before restarting.

**Time-Delay (TDR2)** — Relay prevents nuisance tripping of low-pressure switch during system switchover after defrost.

**Compressor Lockout Switch** — Units with compressor lockout protective device shut down on any safety trip. Determine reason for safety trip. To restart, turn the thermostat to OFF position and then to COOL position.

## Refrigerant Charging

### ⚠ WARNING

To prevent personal injury, wear safety glasses and gloves when handling refrigerant. Do not overcharge system — this can cause compressor flooding.

### ⚠ WARNING

Service valves must be fully backseated to close service port. There is no Schrader valve at the service port, and failure to backseat the valve could result in loss of system charge or personal injury.

NOTE: Do not vent or depressurize unit refrigerant to atmosphere. Remove and reclaim refrigerant following accepted practices.

To check and adjust charge during cooling season, use Tables 3 and 4 and the following procedure:

1. Operate unit a minimum of 15 minutes before checking charge.
2. Measure suction pressure by attaching a gage to suction valve service port.
3. Measure suction line temperature by attaching a service thermometer to unit suction line near suction valve. Insulate thermometer for accurate readings.
4. Measure outdoor coil inlet-air dry bulb temperature with a second thermometer.
5. Measure indoor coil inlet-air wet bulb temperature with a sling psychrometer.
6. Refer to Table 3. Find air temperature entering outdoor coil and wet-bulb temperature entering indoor coil. At this intersection, note the superheat temperature.

7. Refer to Table 4. Find superheat temperature and suction pressure, and note suction line temperature. If unit has higher suction line temperature than charted temperature, add refrigerant until charted temperature is reached.
8. If unit has lower suction line temperature than charted temperature, remove and reclaim refrigerant until charted temperature is reached.
9. If air temperature entering outdoor coil or pressure at suction valve changes, charge to new suction line temperature indicated on chart.
10. This procedure is independent of indoor air quality.

**Heating Mode** — To check system operation during heating cycle, use Table 5. This table indicates whether a correct relationship exists between system operating pressure and air temperatures entering indoor and outdoor units. In heating mode, check should be made approximately 15 minutes after defrost with unit running with a clean coil.

**Table 3 — Superheat Charging Table (Superheat Entering Suction Service Valve)**

OUTDOOR TEMP	INDOOR COIL ENTERING AIR (F) WB															
	50	52	54	56	58	60	62	64	66	68	70	72	74	76		
55	9	12	14	17	20	23	26	29	32	35	37	40	42	45		
60	7	10	12	15	18	21	24	27	30	33	35	38	40	43		
65	*	6	10	13	16	19	21	24	27	30	33	36	38	41		
70	*	*	7	10	13	16	19	21	24	27	30	33	36	39		
75	*	*	*	6	9	12	15	18	21	24	28	31	34	37		
80	*	*	*	*	5	8	12	15	18	21	25	28	31	35		
85	*	*	*	*	*	*	8	11	15	19	22	26	30	33		
90	*	*	*	*	*	*	5	9	13	16	20	24	27	31		
95	*	*	*	*	*	*	*	6	10	14	18	22	25	29		
100	*	*	*	*	*	*	*	*	8	12	15	20	23	27		
105	*	*	*	*	*	*	*	*	5	9	13	17	22	26		
110	*	*	*	*	*	*	*	*	*	6	11	15	20	25		
115	*	*	*	*	*	*	*	*	*	*	8	14	18	23		

LEGEND

WB — Wet Bulb

\*Do not attempt to charge system under these conditions or refrigerant slugging may occur.

**Table 4 — Required Suction-Tube Temperature (F) (Entering Suction Service Valve)**

SUPERHEAT TEMP (F)	SUCTION PRESSURE AT SERVICE PORT (psig)								
	61.5	64.2	67.1	70.0	73.0	76.0	79.2	82.4	85.7
0	35	37	39	41	43	45	47	49	51
2	37	39	41	43	45	47	49	51	53
4	39	41	43	45	47	49	51	53	55
6	41	43	45	47	49	51	53	55	57
8	43	45	47	49	51	53	55	57	59
10	45	47	49	51	53	55	57	59	61
12	47	49	51	53	55	57	59	61	63
14	49	51	53	55	57	59	61	63	65
16	51	53	55	57	59	61	63	65	67
18	53	55	57	59	61	63	65	67	69
20	55	57	59	61	63	65	67	69	71
22	57	59	61	63	65	67	69	71	73
24	59	61	63	65	67	69	71	73	75
26	61	63	65	67	69	71	73	75	77
28	63	65	67	69	71	73	75	77	79
30	65	67	69	71	73	75	77	79	81
32	67	69	71	73	75	77	79	81	83
34	69	71	73	75	77	79	81	83	85
36	71	73	75	77	79	81	83	85	87
38	73	75	77	79	81	83	85	87	89
40	75	77	79	81	83	85	87	89	91

If pressure and temperature do not match on chart, system refrigerant charge may not be correct or other system abnormalities may exist. Do not use table to adjust refrigerant charge.

When recharging is necessary during heating season, weigh in total charge as indicated in separate indoor unit installation instructions. Remove any refrigerant remaining in system before recharging. If the system has lost complete charge, evacuate and recharge by weight. Service port connections are provided on liquid and suction line service valves. For evacuation and recharging, Dial-a-Charge charging cylinder, or similar device, is an accurate device for recharging systems by weight.

## MAINTENANCE

### ⚠ WARNING

Before performing recommended maintenance, be sure unit main power switch is turned off. Failure to do so may result in electric shock or injury from rotating fan blade.

### Lubrication

**COMPRESSOR** — Compressor contains factory oil charge; replace oil when lost. See Table 1 for oil recharge and refer to Carrier Standard Service Techniques Manual, Chapter 1, page 1-21, for oil recharging procedure. Use Carrier PP33-1, Texaco WF-32 or Suniso 3GS oil.

**FAN-MOTOR BEARINGS** — Oiling holes are provided at each end of condenser fan motor. Remove fan motor and

lubricate motor with 32 drops (16 drops per hole) of SAE-10 nondetergent oil at intervals described below:

- Annually, when environment is very dirty, ambient temperature is higher than 105 F, and average unit operating time exceeds 15 hours a day, or
- Every 3 years when environment is reasonably clean, ambient temperature is less than 105 F, and unit operating time averages 8 to 15 hours a day, or
- Every 5 years when environment is clean, ambient temperature is less than 105 F, and unit operating time averages less than 8 hours a day.

### Cleaning

#### CLEANING COILS —

Coils should be washed out with water, or blown out with compressed air. Note that the blow-thru design causes dirt and debris to build up on the inside of the coils.

Clean coil annually or as required by location or outdoor air conditions. Inspect coil monthly, and clean as required. Fins are not continuous through coil sections. Dirt and debris may pass through first section, become trapped between the row of fins and restrict condenser airflow. Use a flashlight to determine if dirt or debris has collected between coil sections. Clean coil as follows:

1. Turn off unit power.
2. Using a garden hose, or other suitable equipment, flush coil from the outside to remove dirt. Be sure to flush all dirt and debris from drain holes in base of unit. Fan motors are waterproof.

**Table 5 — Heating Operation Pressure Table, Fixed Restrictor (High Pressure at Suction Valve, Low Pressure at Liquid Valve, Suction Pressure at Compressor)**

UNIT 38QR	INDOOR DRY BULB TEMP (F)	OUTDOOR TEMPERATURE (F) DRY BULB								UNIT 38QR	INDOOR DRY BULB TEMP (F)	OUTDOOR TEMPERATURE (F) DRY BULB							
			60	50	40	30	20	10	0				60	50	40	30	20	10	0
018C	60	HIGH	219.8	199.2	181.4	166.0	152.5	139.7	128.4	036C	60	HIGH	226.0	205.4	188.0	172.9	160.0	148.4	137.4
		LOW	83.8	71.0	59.3	48.5	38.8	30.2	22.8			LOW	76.1	64.7	54.3	44.7	36.1	28.2	21.2
		SUCTION	68.8	58.6	49.3	40.7	32.9	26.0	19.8			SUCTION	61.9	52.6	44.1	36.3	29.3	22.8	17.0
	70	HIGH	247.7	225.6	206.4	189.5	173.5	159.4	146.5		70	HIGH	254.7	233.0	214.4	198.2	183.9	169.7	158.3
		LOW	85.1	72.1	60.0	49.1	39.3	30.1	23.4			LOW	77.3	65.8	55.3	45.5	36.6	28.8	21.8
		SUCTION	70.4	60.0	50.5	41.8	33.9	26.9	20.6			SUCTION	63.3	54.0	45.3	37.4	30.1	23.5	17.7
	80	HIGH	278.3	254.3	233.5	214.0	196.2	180.3	165.5		80	HIGH	286.7	263.5	243.3	225.5	207.7	193.5	180.4
		LOW	86.5	73.0	60.7	49.7	40.0	31.5	24.0			LOW	78.9	67.1	56.2	46.2	37.3	29.5	22.5
		SUCTION	72.0	61.4	51.7	42.8	34.8	27.7	21.4			SUCTION	65.0	55.4	46.6	38.4	31.0	24.4	18.4
024C	60	HIGH	234.1	210.3	190.4	173.6	159.4	147.3	136.2	048C	60	HIGH	231.6	210.2	191.8	175.4	162.1	148.7	137.6
		LOW	77.9	66.2	55.4	45.5	36.5	28.5	21.2			LOW	80.4	68.2	56.9	46.5	37.2	29.0	21.7
		SUCTION	66.3	56.4	47.3	38.9	31.3	24.4	18.2			SUCTION	67.8	57.6	48.1	39.4	31.5	24.5	18.2
	70	HIGH	262.0	237.0	215.8	197.8	182.5	168.9	156.3		70	HIGH	261.2	238.3	218.5	201.2	184.3	170.2	157.8
		LOW	79.4	67.4	56.4	46.3	37.0	28.8	21.6			LOW	81.8	69.3	57.7	47.1	37.7	29.6	22.2
		SUCTION	68.0	57.9	48.6	40.0	32.2	25.2	18.9			SUCTION	69.4	58.8	49.1	40.3	32.3	25.2	18.8
	80	HIGH	292.6	265.9	243.3	224.2	207.4	191.3	178.0		80	HIGH	293.2	268.6	247.2	226.7	208.6	193.1	178.9
		LOW	80.9	68.6	57.3	47.0	37.6	29.4	22.2			LOW	83.2	70.3	58.5	47.8	37.8	30.2	22.8
		SUCTION	69.8	59.4	49.8	41.0	33.1	25.9	19.6			SUCTION	70.9	60.1	50.2	41.2	33.1	25.9	19.4
030C	60	HIGH	222.3	202.2	185.1	170.4	157.9	146.7	135.9	060C	60	HIGH	228.9	207.5	189.6	173.8	160.4	147.6	136.6
		LOW	83.8	71.4	60.0	49.3	39.7	30.9	23.3			LOW	85.9	72.7	60.9	50.0	40.1	31.3	23.5
		SUCTION	61.8	52.6	44.1	36.2	29.0	22.5	16.7			SUCTION	63.6	53.9	44.9	36.8	29.4	22.7	16.8
	70	HIGH	250.9	229.6	211.2	195.4	181.6	167.8	156.6		70	HIGH	258.3	235.7	215.9	199.0	183.4	168.8	156.4
		LOW	85.2	72.5	60.7	49.9	40.1	31.3	23.7			LOW	86.9	73.8	61.6	50.5	40.5	31.7	24.0
		SUCTION	63.5	54.0	45.3	37.2	29.9	23.2	17.3			SUCTION	65.1	55.2	46.0	37.7	30.2	23.5	17.5
	80	HIGH	282.2	259.3	239.5	222.6	205.6	191.3	178.5		80	HIGH	290.0	265.7	244.4	225.5	206.7	191.3	177.2
		LOW	86.6	73.5	61.5	50.4	40.6	31.9	24.3			LOW	88.4	74.7	62.3	50.9	41.1	32.3	24.5
		SUCTION	65.1	55.4	46.4	38.2	30.7	24.0	18.0			SUCTION	66.5	56.5	47.2	38.7	31.1	24.3	18.2

# TROUBLESHOOTING CHART — HEATING CYCLE

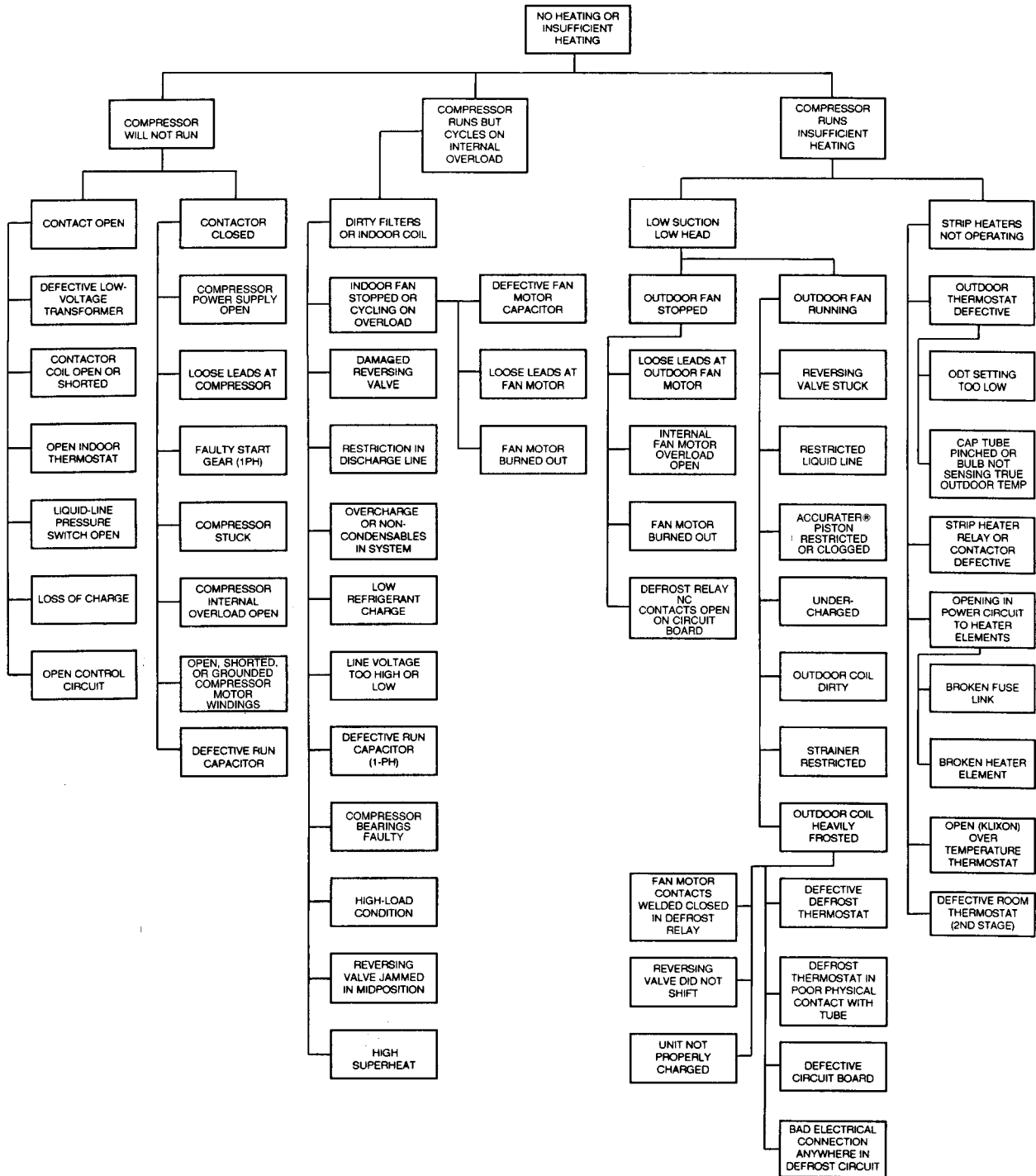

**LEGEND**

- NC** — Normally Closed
- ODT** — Outdoor Thermostat

NOTE: For systems with indoor units equipped with microprocessor control, see separate controls, service, and troubleshooting manual.

# TROUBLESHOOTING CHART — COOLING CYCLE

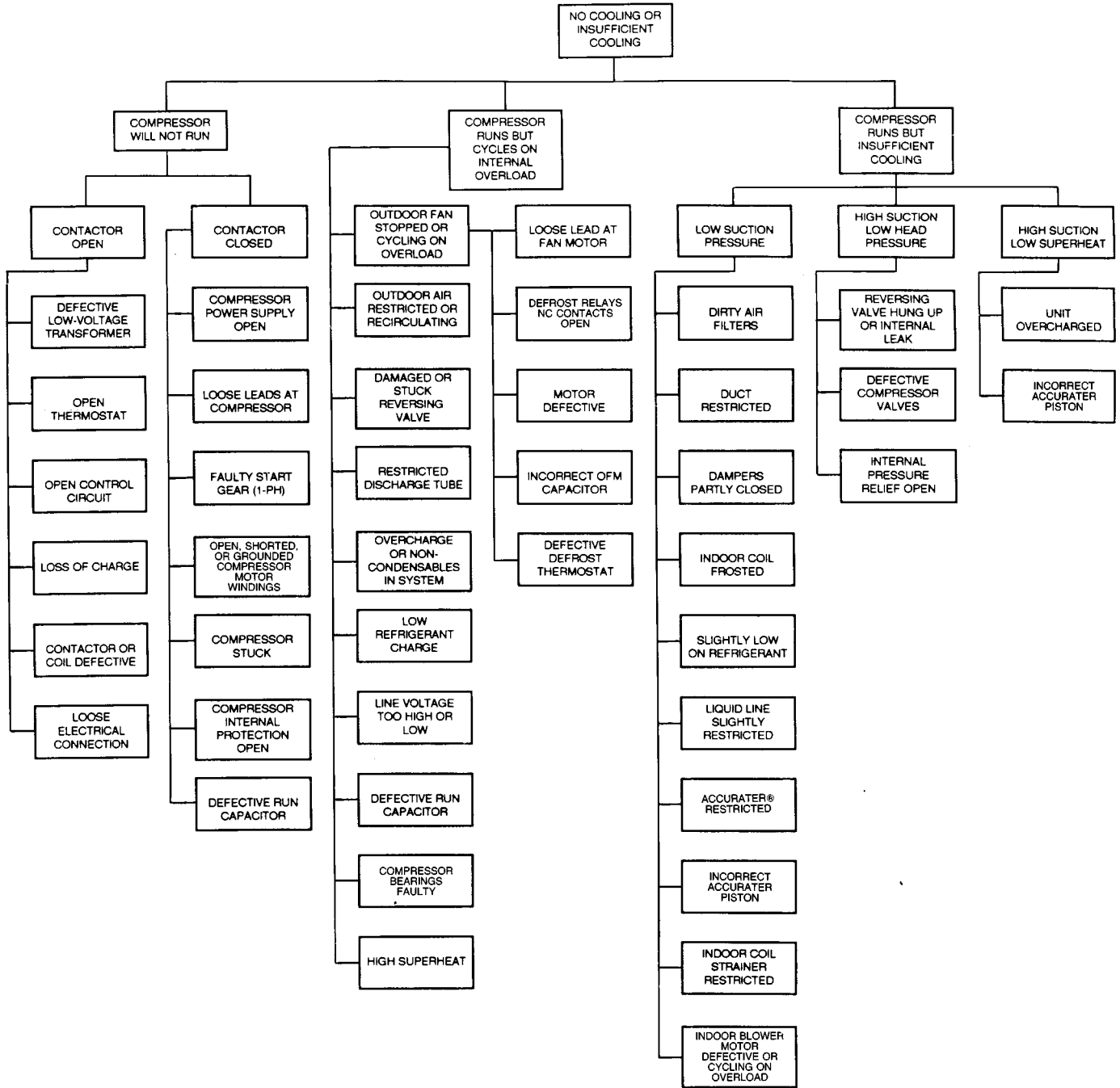

**LEGEND**

**NC** — Normally Closed

NOTE: For systems with indoor units equipped with microprocessor control, see separate controls, service, and troubleshooting manual.





