

Feb. 16, 1965

J. B. KRIPKE

3,169,838

AUTOMATIC HUMIDITY SENSING CONTROL FOR A CLOTHES DRYER

Original Filed Nov. 27, 1959

3 Sheets-Sheet 1

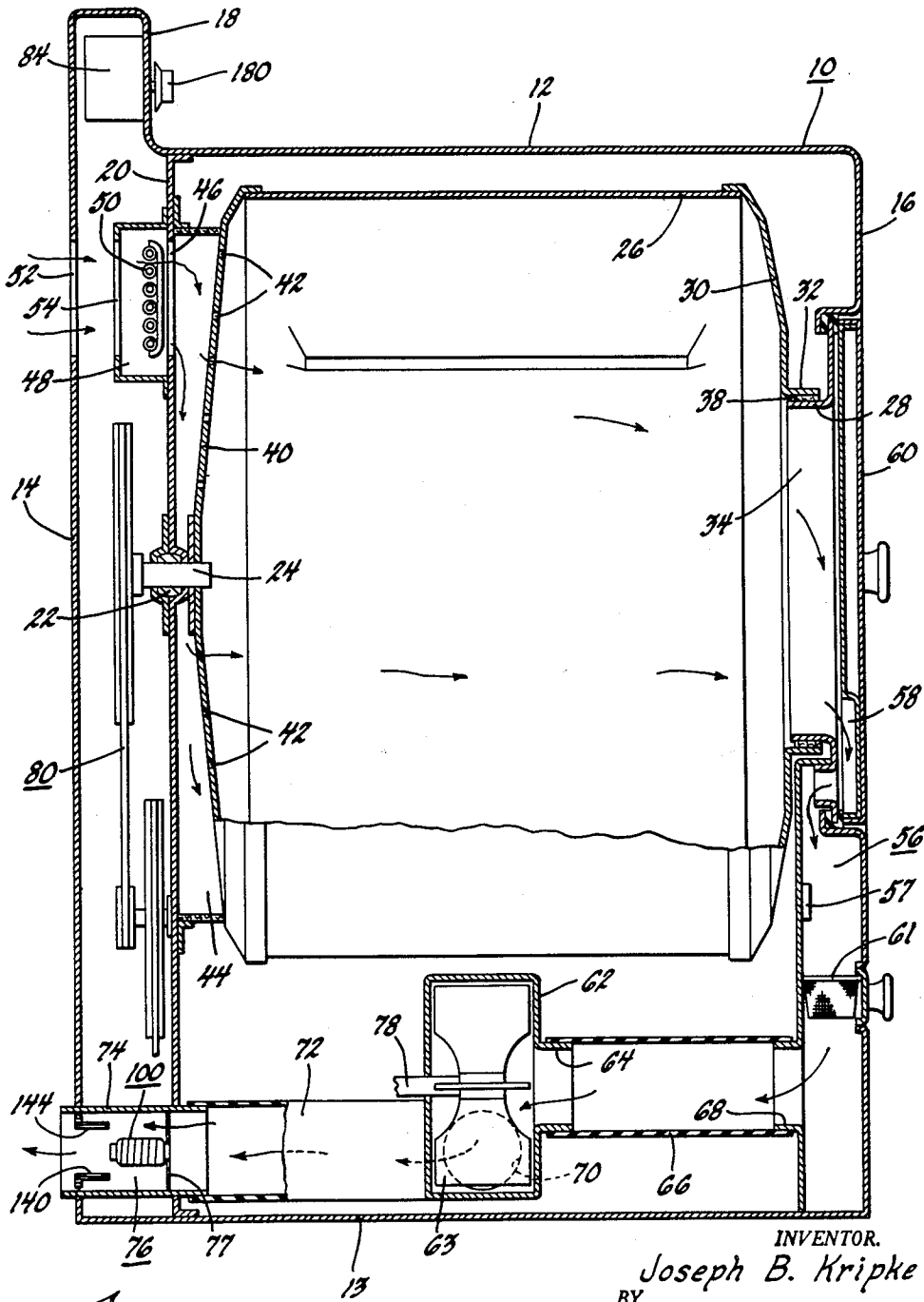

Fig. 1

INVENTOR.
Joseph B. Kripke
BY
Frederick M. Ritchie
HIS ATTORNEY

Feb. 16, 1965

J. B. KRIPKE

3,169,838

AUTOMATIC HUMIDITY SENSING CONTROL FOR A CLOTHES DRYER

Original Filed Nov. 27, 1959

3 Sheets-Sheet 2

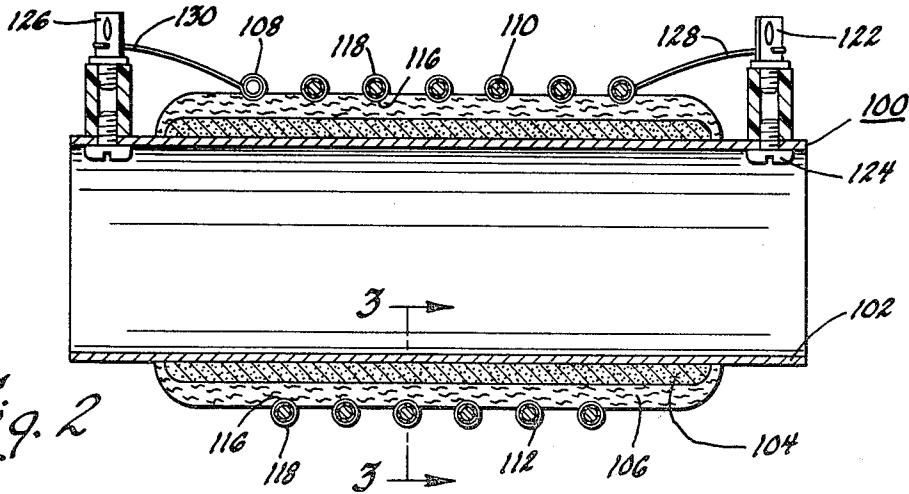

Fig. 2

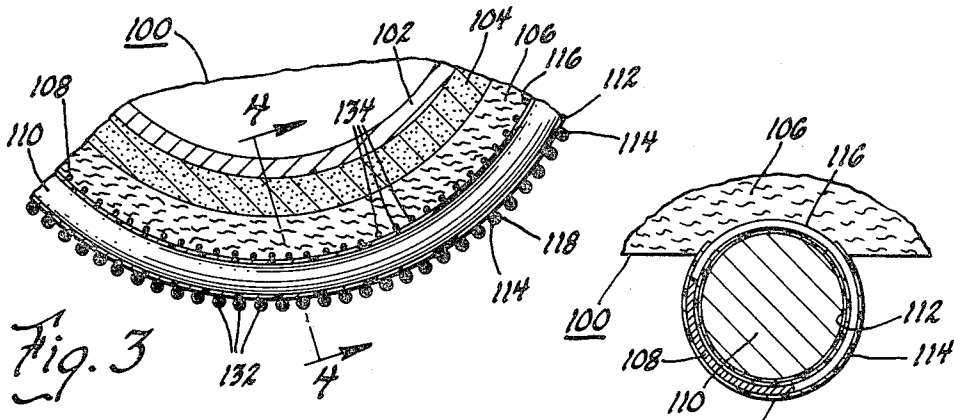

Fig. 3

Fig. 4

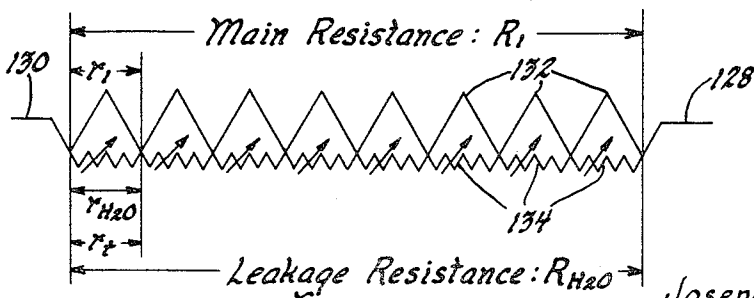

Fig. 5

INVENTOR.
Joseph B. Kripke
BY
Frederick M. Ritchie
HIS ATTORNEY

Feb. 16, 1965

J. B. KRIPKE

3,169,838

AUTOMATIC HUMIDITY SENSING CONTROL FOR A CLOTHES DRYER

Original Filed Nov. 27, 1959

3 Sheets-Sheet 3

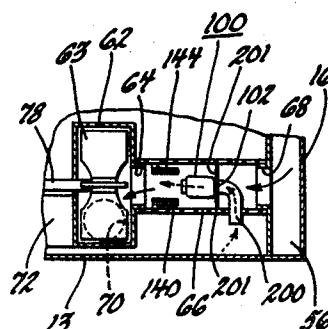
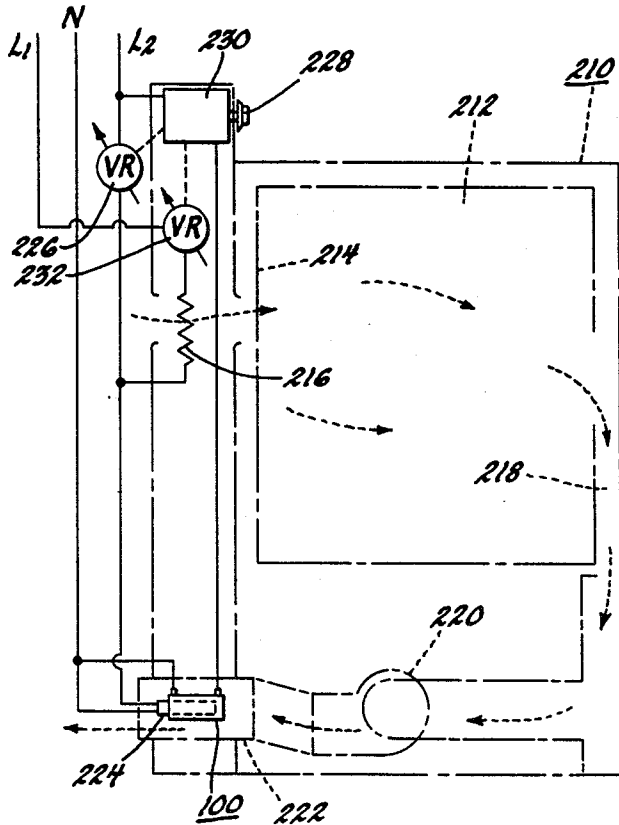

Fig. 8

Fig. 7

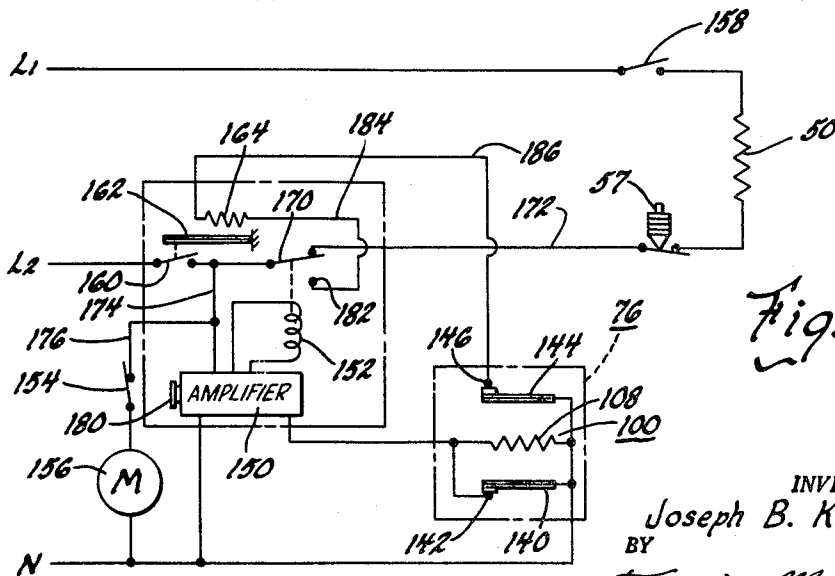

Fig. 6

INVENTOR.
Joseph B. Kripke
BY
Frederick M. Ritchie
HIS ATTORNEY

1

3,169,838

AUTOMATIC HUMIDITY SENSING CONTROL
FOR A CLOTHES DRYERJoseph B. Kripke, Milwaukee, Wis., assignor to General
Motors Corporation, Detroit, Mich., a corporation of
DelawareOriginal application Nov. 27, 1959, Ser. No. 855,812, now
Patent No. 3,110,005, dated Nov. 5, 1963. Divided
and this application Nov. 24, 1961, Ser. No. 154,713
5 Claims. (Cl. 34-45)

This invention relates to a domestic appliance and more particularly to an improved humidity sensing element; and is a division of my copending application S.N. 855,812, filed November 27, 1959, now U.S. Patent 3,110,005, granted November 5, 1963.

The clothes drying art has long sought a method whereby the drying cycle may be terminated at the correct end point automatically. Past efforts toward a dryness control have been directed primarily to sensing sudden changes in dry bulb temperature as an indication of clothes dryness. However, relatively few attempts have successfully tied the termination of a clothes drying operation to the moisture content of the fabric. One of the difficulties with this latter approach is in the development of a humidity sensor which is inexpensive to manufacture and which will be dependable over an extended life of operation. A dryness control to be completely effective, should be able to compensate for different types of fabric, the weight of the fabric and the weight of the water in the load being dried. Accordingly, it is to the solution of these and other problems that this invention is directed.

It is an object of this invention to provide a humidity sensor which senses the actual moisture content or absolute humidity of the surrounding air.

Another object of this invention is the provision of a humidity sensor for a variable temperature air stream, said sensor having a constant temperature reference for stabilizing sensor operation.

It is also an object of this invention to provide a humidity sensor for a clothes dryer which is cooled by a constant temperature reference to compensate for the advance in dryer ambient temperatures with consecutive drying cycles.

A further provision of this invention is the provision of a humidity sensor having a base reservoir portion and a moisture attracting portion, said base reservoir portion containing an hygroscopic salt which is given up gradually to said moisture attracting portion as a replenishment for salt leached from said attracting portion.

It is a further object of this invention to sense the amount of moisture present in an air stream and to provide to a balanced circuit amplifier a signal as a function of the percent of moisture sensed.

Another object of this invention is the provision of a humidity sensor which depends upon the amount of moisture present to create a parallel resistance path between the adjacent turns of a wire coil.

It is also an object of this invention to terminate a fabric drying cycle in accordance with fabric moisture content automatically.

It is also an object of this invention to terminate the drying cycle of a fabric load when the load is at a predetermined degree of dryness.

A further object of this invention is the provision of a dryness control which can compensate for type of fabric, weight of fabric and weight of water in the fabric load.

A still further object of this invention is the provision of a drying cycle which is terminated automatically with the clothes at a suitable temperature for comfortable handling.

2

Another object of this invention is the provision of a drying cycle with an automatic temperature responsive cool-off period at the end of a drying cycle.

A more specific object of this invention is the provision of a humidity sensing element which is comprised of a hollow support tube encased with a layer of porous material mixed with an hygroscopic salt, a sleeve of absorbent wicking and a helically wound coil of insulated high resistance wire, said coil having a non-insulated portion in electrical contact with said sleeve.

Further objects and advantages of the present invention will be apparent from the following description, reference being had to the accompanying drawings wherein preferred embodiments of the present invention are clearly shown.

In the drawings:

FIGURE 1 is a sectional view of a clothes dryer suitable for use with this invention;

FIGURE 2 is a sectional view of the humidity sensing device of this invention;

FIGURE 3 is a fragmentary sectional view taken along line 3-3 in FIGURE 2;

FIGURE 4 is a fragmentary sectional view taken along line 4-4 in FIGURE 3 to show the relationship of the insulated and non-insulated portions of a single resistance wire convolution to the moisture attracting wicking of the sensing element;

FIGURE 5 is a schematic circuit diagram illustrating the electrical theory of the humidity sensing arrangement of this invention;

FIGURE 6 is a schematic wiring diagram for controlling a clothes dryer with the humidity sensing device of this invention;

FIGURE 7 is a diagrammatic view of a clothes dryer controlled by a modified version of the humidity sensing arrangement of this invention; and

FIGURE 8 is a fragmentary sectional view partly in elevation of a modified mounting arrangement for the humidity controller of this invention.

In accordance with this invention and with reference to FIGURE 1, a clothes dryer 10 is shown comprised of a casing 12 having a rear wall 14, a front wall 16 and a control housing 18. Disposed between the top wall 12 and bottom wall 13 of the casing is a vertical drum support bulkhead 20 having a centrally located universal support bearing 22 in which a drum shaft 24 is rotatably mounted. The tumbling drum 26 is supported by and affixed to the shaft 24 at one end thereof and is supported at its other end on a port plate 28 carried by the front wall 16 of the dryer cabinet. More particularly, the front wall 30 of the tumbling drum includes an axially directed outwardly turned cylindrical flange 32 which overlies an intumed flange 34 on the port plate 28. Sealing material such as felt 38 may be interposed along with a pair of bearing support blocks between the flanges 32 and 34 for rotatably supporting the tumbling drum 26. The rear wall 40 of the tumbling drum is perforated as at 42 to place the interior of the tumbling drum in communication with an annular chamber 44 adjacent the rear wall of the tumbling drum. The chamber 44 communicates by way of an opening 46 in the bulkhead 20 with a heating chamber 48 in which a main heater 50 is disposed. Both the cabinet rear wall 14 and the heating chamber 48 have openings as at 52 and 54, respectively, to permit a series flow of air between the atmosphere and the interior of the tumbling drum. As the air leaves the front of the tumbling drum, it communicates with a front duct 56 by means of a passageway 58 interposed between the access door 60 and the port plate 28. A removable lint screen 61 may be interposed in the air

3

flow path within the front duct 56. Beneath the tumbling drum 26 and within the dryer cabinet, a conventional blower 62 is disposed which has an inlet 64 connected by means of a flexible conduit 66 to an outlet 68 from the front duct 56. The blower outlet 70 communicates by means of a second flexible conduit 72 with a cylindrical exhaust or humidity sensing element support housing 74 in which a humidity sensing assembly shown generally at 76 is disposed. The assembly includes a humidity sensing element which is suspended by struts 77 in the housing 74. The blower 62 and the tumbling drum 26 are both operated by a conventional motor (shown schematically in FIGURE 6)—the blower impeller 63 by means of a shaft 78 and the tumbling drum 26 through a belt and pulley system shown generally at 80.

The air flow system of the dryer 10 which is suitable for use with this invention is designed as follows. With the blower 62 operating, drying air will be drawn into the dryer cabinet through the opening 52 in the rear wall 14 thereof. This air will enter the heating chamber 48 by means of the heating chamber inlet 54 and will pass over the heaters 50 prior to entering the annular chamber 44 adjacent the rear wall 40 of the tumbling drum 26. The heated air is drawn equally through all of the perforations 42 in the drum wall 40 and will flow around and through the clothing being tumbled by the rotating drum 26. At this point the moisture in the damp clothes is vaporized and is entrained in the air flow passing through the tumbling drum. This moisture-laden air will then be drawn through the passageway 58 and into the front duct 56 where the temperature thereof will be sensed by a thermostat or temperature responsive device 57, which may be adjustable in accordance with the drying temperatures desired by the user. The thermostat 57, in turn, controls the primary heater 50. From the front duct 56 the air will be filtered through a conventional lint screen 61 prior to entering the duct or conduit 66 leading to the inlet 64 of the blower. On the outlet side of the blower the moisture-laden air will be forced by way of the conduit 72 to the humidity sensing support housing 74 in which the humidity sensor assembly 76 is disposed. At this point in the air flow system the absolute humidity or moisture content of the air will be sensed and a signal indicative of such moisture content will be sent from the sensing device 76 to a dryer control shown generally at 84. When the air indicates a dry condition for the clothes within the tumbling drum 26, the heater 50 will be permanently deenergized and the drying cycle terminated with a predetermined cool-off period during which the fabrics reach a temperature suitable for handling.

Prior attempts to terminate a drying cycle by sensing humidity have met with difficulties in developing a humidity sensing element which will operate over extended periods with consistent operating characteristics. Further, the prior devices have been unable to recognize or distinguish between different fabrics or different size drying loads. This shortcoming stems primarily from the fact that the prior devices are unable to sense slight variations in moisture content carried by a fastly moving air stream. The humidity sensing arrangement 76 of this invention overcomes these problems in a device which may be mass produced at extremely low cost and which has an unusually long and dependable life.

Reference may now be had to FIGURES 2, 3 and 4 for a complete understanding of the construction of this novel humidity sensing element or sensor 100. The purpose of this element is to sense the amount of moisture present in an air stream passing thereover by offering a changing resistance indicative of the moisture present to a balanced circuit amplifier. The functioning of the sensor depends upon the amount of moisture present to create a parallel resistance path between adjacent turns of a wire coil. More particularly, the humidity sensor

4

100 is comprised of a hollow tubular shaft or cylinder 102 of aluminum or other suitable heat conducting material. The tube or cylinder 102 is encased by a layer of plaster of Paris 104 or other porous plaster-like moldable material which has been mixed with a solution of an hygroscopic salt such as lithium chloride dissolved in water. Since the plaster of Paris layer 104 is porous, this portion of the element 100 serves as a reservoir or retainer for excess hygroscopic salt throughout the life of the element. Overlying the plaster of Paris layer 104 and concentric therewith is a sleeve 106 of asbestos wicking or other absorbent material. The wicking 106 lies in juxtaposition to the plaster of Paris layer 104 so that it may receive the lithium chloride or hygroscopic salt from its plaster of Paris reservoir. Although the plaster of Paris has been said to be mixed with lithium chloride, it should be recognized that any other hygroscopic salt may be entrapped in the pores of the porous layer 104—for example, lithium bromide. It is important only that an hygroscopic material be placed in a position of reserve adjacent the wicking material so that the wick may be replenished with this hygroscopic salt throughout the life of the humidity sensing element 100. In this way salt leached from the wicking is continually replaced from the porous reservoir.

The foregoing components of the sensing device, namely the wicking 106 and the hygroscopic salt reservoir 104, provide the means for attracting and holding the moisture from the air being passed thereover. In order for the sensor 100 to be effective in controlling an electrical appliance, it is necessary that means be provided for interpreting the humidity indicating signals from the sensor. The signals are in the form of a total resistance across the sensor 100 which varies in accordance with the moisture entrapped by the sensor. To provide an interpretable resistance path in conjunction with the wicking material 106, it is necessary that a coil 108 of very fine high resistance wire be wrapped around the asbestos wicking sleeve 106. This wire may be of Nichrome .002 inch in diameter and may have a resistance of one hundred sixty-nine ohms per foot. As this resistance wire 108 is extremely fine, it is necessary that a support mandrel 110 be utilized as the carrier for the resistance wire 108. Thus, the resistance wire is tightly, helically wound around the mandrel 110. After the resistance wire 108 is snugly wrapped about the mandrel 110, the mandrel 110 is then wound helically about the asbestos sleeve wicking 106. It is important to note that the mandrel 110 is nothing more than a carrier or mechanical support for the wire 108 and performs no electrical function. The wire 108 is electrically insulated from the mandrel 110 and the mandrel forms no portion of the electrical control circuitry of the sensing element 100. Both the mandrel 110 and the resistance wire 108 are insulated or coated by an enamel 112 on the mandrel and 114 on the resistance wire 108. Prior to winding the resistance wire wrapped mandrel about the asbestos sleeve 106, the insulation 114 is removed as at 116 to expose the bare wire of the resistance conductor 108. Thus, after the mandrel is wrapped about the asbestos sleeve, the un-insulated portion 116 of the resistance wire 108 is embedded in the asbestos wicking 106 while an insulated portion 118 extends above the asbestos wicking 106. In other words, the insulation is removed from the surface of the resistance wire coil where the wire comes in contact with the asbestos wicking. Completing the humidity sensor 100 is a first terminal or spade connector 122 connected as by a bolt 124 to the cylindrical tubing 102. At the other end of the tube 102 is a second terminal or spade connector 126 connected in similar fashion. The resistance wire coil is provided with a first terminal end 128 electrically connected to the spade or terminal 122 while the other terminal end 130 of the resistance coil is electrically fastened to the terminal spade or connector

5

126. When the humidity sensor 100 is placed in a control circuit, the sensor 100 may be connected by means of the spades or connectors 122 and 126 into the circuit to be humidity responsively controlled. The entire sensor 100 is light, compact and adapted for easy installation within any conventional appliance air conduit.

The electrical theory involved in connection with the humidity sensing element 100 is shown schematically in FIGURE 5. The schematic is depicted as though the resistance coil 108 were laid out flat on a continuous layer of asbestos or absorbent wicking. Note that between the terminal ends 128 and 130 there are a plurality of coil segments or convolutions 132. The convolutions of the coil 108 provide a fixed resistance path between the terminal ends 128 and 130. However, the bared or non-insulated portion of the convolutions 132, which extend into the asbestos wicking 106, provide variable resistance paths 134 between each convolution 132 of the resistance coil. As shown in the FIGURE 5 schematic, each convolution 132 of the resistance coil 108 provides an increment of resistance r_1 . The variable resistance path through the asbestos wicking 106 provides a variable resistance in accordance with the moisture content of the asbestos wicking as indicated by r_{H_2O} . Therefore, the total resistance (r_t) is equivalent to the resistance (r_1) of one convolution 132 of the wire coil 108 times the resistance (r_{H_2O}) of the variable resistance to current flow path through the moisture-laden asbestos wicking divided by the resistance (r_1) through one convolution 132 of the resistance wire 108 plus the resistance (r_{H_2O}) of the variable resistance path through the asbestos wicking, or in formula form

$$r_t = \frac{r_1 \times r_{H_2O}}{r_1 + r_{H_2O}}$$

This formula depicts both parallel paths, one of which is fixed through each convolution of the resistance coil 108 and the other path of which is variable through the variable moisture-laden asbestos wicking 106 between the exposed adjacent uninsulated portions 116 of the coil 108. The main resistance R_1 of the coil 108 alone is equal to N times r_1 ($R_1 = Nr_1$) wherein N equals the number of convolutions or turns of the resistance coil 108 wrapped about the mandrel 110 between the terminal ends 128, 130. On the other hand, the total leakage resistance (R_{H_2O}) is equivalent to the sum of all of the resistance paths between adjacent convolutions through the moisture-laden asbestos wicking. Thus the total resistance (R) including both main resistance and leakage resistance is equal to N times r_t ($R = Nr_t$). To increase sensitivity of the humidity sensing element 100 it is necessary only to increase the main resistance (R_1) of the coil 108. The leakage resistance (R_{H_2O}) varies only with the moisture present in the asbestos wicking sleeve 106. Thus, we have a resistance path disposed in an air stream which has parallel electrically conducting paths. One of such paths has a fixed resistance and the other of such paths has a variable resistance. When a current is passed through the coil 108 by connecting the sensor 100 into an electrical circuit, such as for a dryer, a signal is given out or indicated by the sensor 100 which varies in accordance with the amount of moisture absorbed by the asbestos wicking 106. Such absorbed moisture provides the variable flow paths between adjacent convolutions of the uninsulated portions 116 of the resistance wire. The function of the asbestos wicking 106 is to absorb the moisture from the surrounding air to provide a conductive path between the adjacent convolutions 132 of the resistance coil. As aforesaid, the resistance of the leakage path between exposed portions of the coil 116 varies with this amount of moisture in the asbestos wick. Since each of these moisture created variable resistance paths is in parallel with one convolution of the resistance coil

6

108, the result is a sensor whose overall resistance is determined by the two parallel paths, one of which, the moisture path, is variable.

With such a sensor design an element is provided which has a definite resistance value for any given absolute humidity. A control can be made to operate at a predetermined absolute humidity by turning the control circuit to that resistance which correlates the desired humidity with a desired clothes dryness condition. Since a fast moving air stream containing moisture is reluctant to deposit such moisture on the surface of the asbestos wick, a material is needed which will attract the moisture. Thus, the porous plaster of Paris reservoir 104 may be impregnated with an hygroscopic salt, such as lithium chloride, or other material capable of attracting moisture. The amount of lithium chloride used to impregnate the base 104 is selected so as not to over saturate the asbestos wick 106. Note that the asbestos wick 106 is not saturated with the lithium chloride or hygroscopic salt directly. The salt is placed in solution with the water which is used to mix the plaster of Paris which underlies the asbestos sleeve 106. The strength of solution used is determined by empirical study in order to secure the correct amount of salt transmission between the reservoir and the wicking.

Although the humidity sensor 100 may be used in many applications where it is desired to control in accordance with absolute humidity, its application has been found particularly effective in a clothes dryer. When so applied, a control circuit seen in FIGURE 6 is utilized to operate the dryer of FIGURE 1 in response to the signals originating with the sensor 100. The overall humidity sensing arrangement 76 includes the sensor 100, a starting bimetal or thermally responsive switch 140 operating on a fixed contact 142, and a cool-down bimetal or thermally responsive switch 144 operating on a fixed contact 146. The sensor 100 and more particularly the resistance coil 108 is adapted to be installed in a housing or duct 74 through which air exhausts from the dryer 10. Both the cool-down switch 144 and the start bimetal switch 140 are disposed in the same general area so that both the temperature and humidity condition of the exhaust air may be sensed. Since the sensing coil 108 produces or indicates signals in the neighborhood of fifty microamps, it is desirable to have in the dryer control 84 an amplifier 150 including a solenoid 152 which is selectively energized by the signals from the sensing coil 108. The circuitry of FIGURE 6 may include also a door switch 154 for interrupting dryer operation whenever the door 60 is opened. A motor 156 is connected to the belt and pulley system 80 for rotating the tumbling drum 26 and to the shaft 78 of the blower 62 for inducing an air flow through the tumbling drum. Disposed within the circuit for heater 50 is the thermostat 57 which selectively interrupts energization of the heater in accordance with a predetermined temperature selection amenable to the fabric being dried. A conventional motor speed switch 158 may be included to prevent operation of the heater should the motor fail to operate in driving the blower or rotating the tumbling drum. In accordance with this invention the circuitry includes a manually closed master switch 160 which is adapted to be opened by a bimetallic actuating member 162 which is flexed or actuated by a heater 164 to terminate automatically the drying cycle as will be described more fully hereinafter.

The function of the start bimetal switch 140 acts to short out the coil 108 of the sensor 100 to prevent the dryer from shutting down too quickly, i.e. to sense falsely an indication of dryness before the fabric within the tumbling drum has started giving up its moisture to the heated air. There is a period, generally below exhaust air temperatures of approximately 115° F. while the air is being heated at the beginning of the cycle, that substantially dry air would be sensed at the coil 108. This bimetal 140 serves to shunt out coil 108 during this pe-

riod so that the sensor is in effect made inoperative until moisture is entrained in the air exhausting from the dryer.

The cool-down bimetal switch 144 functions at the end of the drying cycle and is adapted to close upon the contact 146 at temperatures below approximately 120 degrees. This provides the cool-down operation which tends to terminate the drying cycle with a period of tumbling in relatively cool air for wrinkle-free results. Once the sensing coil 103 has indicated to the amplifier 150 that the clothes are dry, a cycle is established placing the cool-down switch 144 in the circuit as will be understood more fully hereinafter.

In operation a drying circuit provided with a sensor 100 of this invention is energized when the switch 160 is manually closed. Current will flow from L_2 through the switch 160, a switch blade 170 of relay 152, line 172, through the thermostat 57, the heater 50, the safety switch 153 (closed when the motor 156 is in operation) to L_1 . At the same time, power will flow from L_2 through the start switch 160, line 174, line 176, the door switch 154, the motor 156 to the neutral side of the line N. Thus, the heater 50 and the motor 156 are in operation and a drying cycle is initiated. With the energization of the blower 62 by means of the motor 156, air will start flowing past the sensor 100 and more particularly the resistance coil 103. This first relatively cool air will also be relatively dry and will falsely indicate a dry condition for the clothes. For this reason the bimetallic switch 140 is placed in parallel with the resistance coil 103 and adapted to be closed below approximately 115° F. Of course, with the heater 50 energized, the air flowing past the sensor 100 will soon heat up and will start to vaporize the moisture from the clothes load being tumbled in the drum 26. As the temperature rises above 115°, the switch 140 will lift from the contact 142 and the sensing element 103 will be placed solely in the circuit with the amplifier 150 as the means for amplifying and evaluating the humidity responsive signals produced. The amplifier 150 is provided with a control knob 180 which acts through a potentiometer to balance the circuit within the amplifier in accordance with the degree of dryness of the fabric desired. When the resistance balanced into the amplifier 150 matches the resistance total across the coil 103, the solenoid 152 will be energized to move the relay switch blade 170 to a contact 182, thereby conditioning the cool-down circuit for energization. At this time current will flow from L_2 , start switch 160, the relay switch 170, contact 182, line 184, the bimetallic disconnect switch heater 164 and line 186 to the cool-down bimetallic switch 144 and from there to the other side of the line N. So long as temperatures within the exhaust housing 74 are above approximately 120° F., the bimetallic switch 144 will be opened and the heater 164 thereby deenergized. As the temperatures reduce below the 120° F. setting, the bimetal 144 will close, the cool-down circuit will be energized and the heater 164 will start warming the bimetallic actuating element 162. In approximately twenty-five to forty seconds after the bimetallic 162 is heated, the master switch 160 will be opened and the drying cycle terminated. During this cool-down period, the warm temperature of the dried clothes will be reduced to a suitable temperature for handling and the relatively cool air passing over the tumbling clothes will aid in minimizing wrinkles. Any suitable amplifier 150 may be used in a circuit equipped with this invention. The amplifier could be transistorized or power transistors might be considered to eliminate the relay in the circuit.

Where the clothes dryer 10 is being used for one drying cycle after another without a cool off period between, it has been found desirable to alter the mounting arrangement for the sensor 100 shown in FIGURE 1. With repeat cycles the sensor tends to heat up and resists absorbing moisture from the air at the start of the later cycles. For this reason, a modified mounting arrangement is shown in FIGURE 8, wherein the hollow cylinder

102 of the sensor 100 is connected to a conduit 200 extending through a wall of the air flow system duct 66 leading to the inlet of the blower. The duct 66 may be replaced by the support housing 74 of FIGURE 1—the size, of course, being adjusted to the distance between the blower inlet 64 and the outlet 68 of the front duct 56. In any event struts 201 act to suspend the sensor centrally in the air stream. Thus, the blower 62 serves to draw air from the outside atmosphere (dashed arrows) through the center or inside of the sensor 100 by way of conduit 200 while the moisture-laden air from the tumbling drum is drawn about the outside of the sensor (solid arrows) and in contact with the moisture absorbing asbestos wicking 106. With this arrangement, the dryer 10 may be used throughout repeat cycles without the sensor 100 changing in operating characteristics. The relatively cool and stable temperature of the atmosphere provides a constant temperature reference for the sensor 100. Therefore, each drying cycle may be initiated with the sensor in a constant temperature state.

Another embodiment whereby the sensor 100 of this invention may be used to operate a modified clothes drying cycle is shown in FIGURE 7. In this arrangement a dryer 210 is provided with a tumbling drum 212 connecting through a perforated rear wall 214 with a heating element 216. At the opposite end of the tumbling drum 212 the air flow is connected by means of a front duct 213 with a blower 220, the outlet of which is connected to the support housing 222 which may be substantially the same as 74 described in connection with the foregoing or preferred arrangement. In the FIGURE 7 circuitry, a heater 224 is inserted within the hollow sensor 100 and adapted to vary the rate at which moisture will be absorbed by the wicking 106 of the sensor. The hotter the sensor 100, the greater will be the resistance to taking moisture out of the dryer exhaust air. The output of the heater 224 is controlled by a variable resistance controller 226 which is positioned in accordance with a predetermined clothes dryness programmed by an operator through the knob 228. This knob 228 adjusts a controller or amplifier 230 in accordance with the signal received from the sensor 100 and in turn positions a rheostat or variable resistance controller 232 in the circuit to the heater 216. In this way a constantly changing heat supply is provided for the tumbling drum 212. Since clothes can stand more heat when wet than when dry, high heat is provided at the start of each drying cycle and is diminished gradually as the clothes drying cycle progresses to the selected dryness end point.

In operation the humidity sensing circuit of FIGURE 7 includes the humidity sensor 100 (FIGURE 2) which is intended for use as the input furnishing element in a humidity control circuit. It consists of the cylinder 102 supporting the absorbent material such as the asbestos wicking 106. Within the hollow cylinder a heating element 224 is mounted and the entire assembly is then positioned within an exhaust duct or chamber 222. As moist air passes through the duct 222, the porous wicking material will be penetrated by moisture. This moisture picked up from the clothes being dried acts to vary the resistance of the element 100 in the control circuit, causing the primary heating element 216 to change its heat input to the air entering the tumbling drum 212. The amount of moisture in the passing air establishes the amount of moisture trapped in the porous cylinder of wicking 106. As this moisture is diminished or dries out, the resistance across the sensor 100 is increased and this signal passed on to the controller 230. By means of conventional relay devices in the controller 230 this signal is interpreted and the variable resistance 232 is altered to reduce the power supply to the primary heater 216. When the sleeve of wicking 106 is completely dry, the resistance of the sensor 100 is at a maximum and the primary drying action will be terminated with the deenergization of the heater 216.

In FIGURE 7 the output of the sensor heater 224 has been made adjustable through a variable resistance 226. Thus, the extent of the drying effect of the heater 224 on the moisture trapped in the porous wicking of the sensor can be controlled and set at specific levels depending on the nature of the material within the tumbling drum to be dried.

Another method whereby the heater 224 may produce an adjustable effect on the sensor is to make the penetration of the heater 224 within the cylinder 102 variable—the heat output of the heater 224 remaining fixed. In this way, the more that the heater 224 inserts within the tubular support element 102, the more reluctant will be the wicking to taking on the moisture from the tumbling drum air passing thereover. That is, the sensor 100 will be heated and dry out in direct proportion to the amount of heater insertion.

By tying a humidity sensor to a controller for an infinitely variable primary heating element for a dryer, it is possible to use the maximum temperatures within the tumbling drum 212 which the fabrics can withstand. Thus, as wet clothes are placed in the dryer, the maximum heat output of the heating element 216 may be used. As the clothes start to dry, this heat output is gradually reduced until the fabric is completely dry, at which point the output of the heating element 216 will be reduced to zero and the drying cycle terminated. By tying the heat output to the dryness of the clothes, the duration of a drying cycle may be reduced to the absolute minimum.

It should now be seen that an improved humidity sensing element has been devised for use as a controller in a domestic dryer or for use in any humidity control arrangement. The design of the sensor whereby a quantity of hygroscopic salt is entrapped in a porous base material for gradual release to a moisture absorbing wicking is believed to embody a humidity sensor design which will have exceptionally long life with constant operating characteristics. A helically wound coil which is insulated in an air stream but noninsulated in a wicking base, may be used to provide a variable resistance path which is indicative of the absolute humidity of any fluid medium passing thereover. A signal so indicated may then be transposed through auxiliary amplifying equipment to operate an appliance such as a domestic clothes dryer.

In addition a control cycle has also been devised whereby the humidity sensing element of this invention is used in conjunction with temperature responsive devices to effect proper dryer operation during the warm up portion of a drying cycle and during the cool-down portion of the cycle, the latter to prevent wrinkles in the fabric being dried. A further concept of this invention is embodied in a drying system wherein the output of the primary heater is diminished as the moisture is removed from the fabric. More particularly, as the moisture entrained by a humidity sensor decreases, a signal is produced indicative of such moisture decrease and the output of the primary heater reduced in accordance therewith. Such a system is particularly effective in saving on the consumption of electricity as well as in effecting a drying cycle, the total duration of which is kept to a minimum.

While the embodiments of the present invention as herein disclosed, constitute preferred forms, it is to be understood that other forms might be adopted.

What is claimed is as follows:

1. A control circuit for a clothes dryer having a casing defining a rotatable tumbling chamber and an air flow exhaust duct comprising, a power supply, a master switch for said power supply, means for opening said master switch after a predetermined delay, a heater for said tumbling chamber, a thermally responsive switch in series with said heater, means for alternately conditioning said heater or said master switch opening means for energization, means for adjusting said alternately conditioning means in accordance with a presettable degree of clothes dryness, a

humidity sensing arrangement in communication with said exhaust duct and having a hollow humidity sensing element, a start bimetal switch in parallel with said sensing element and a cool-down bimetal switch in series with said master switch opening means, said start bimetal switch opening at a predetermined increase in air flow temperature to place said sensing element in operative relationship with said alternately conditioning means, said cool-down bimetal switch closing at a predetermined decrease in air flow temperature to condition said master switch opening means for energization, and said sensing element in accordance with the humidity of said air flow related to said preset degree of clothes dryness being adapted to actuate said alternately conditioning means for energizing said heater when said humidity is above a predetermined value and said thermally responsive switch is closed and for energizing said master switch opening means when said humidity is below a predetermined value and said cool-down switch is closed.

2. The control circuit of claim 1 wherein said hollow humidity sensing element is disposed in said exhaust duct with its exterior exposed to said air flow from said tumbling chamber and with its interior exposed to atmospheric air, said exterior of said sensing element supporting a base portion of porous material, a wick portion of absorbent material in juxtaposition to said base portion, and an hygroscopic, material yieldingly retained in said base portion for release to said wick portion.

3. A drying cycle control circuit for a clothes dryer having a casing defining a drying chamber and means defining an air flow from said chamber, a power supply, a master control for said power supply, means for actuating said master control for disconnecting said power supply, means for heating said drying chamber, means for alternately conditioning said heating means or said master control actuating means for energization, a clothes dryness sensing arrangement in communication with said air flow and having a humidity sensing element, an air flow temperature responsive start means in shunt relationship with said sensing element and an air flow temperature responsive cool-down means in series with said master control actuating means, said start means adapted at a predetermined increase in air flow temperature to place said sensing element in operative relationship with said alternately conditioning means, said cool-down means adapted at a predetermined decrease in air flow temperature to condition said master control actuating means for energization, and said sensing element in accordance with the humidity in said air flow being adapted to actuate said alternately conditioning means for energizing said heating means when said humidity is above a predetermined value and for energizing said master control actuating means when said humidity is below a predetermined value.

4. The drying cycle control circuit of claim 3 wherein said humidity sensing element has an outside exposed to said air flow and an inside exposed to the atmosphere, said outside supporting a base portion of porous material, a wick portion of absorbent material in juxtaposition to said base portion, and an hygroscopic material yieldingly retained in said base portion for release to said wick portion.

5. A drying cycle control circuit for a dryer having a casing defining a drying chamber and means defining an air flow path from said chamber, a power supply, a master control means for said power supply, means for actuating said master control means for disconnecting said power supply, means for heating said chamber, means for alternately conditioning said heating means or said master control actuating means for energization, a dryness sensing arrangement in communication with said air flow and having a humidity sensing element, and an air flow condition responsive start means in shunt relationship with said sensing element, said start means adapted at a predetermined change in said air flow condition to

place said sensing element in operative relationship with said alternately conditioning means, and said sensing element in accordance with the humidity in said air flow being adapted to actuate said alternately conditioning means for energizing said heating means when said humidity is above a predetermined value and for energizing said master control actuating means when said humidity is below a predetermined value.

References Cited in the file of this patent

UNITED STATES PATENTS

2,741,856	Hall -----	Apr. 17, 1956
2,820,304	Horecky -----	Jan. 21, 1958
2,895,230	Reiley -----	July 21, 1959
3,050,865	Morey -----	Aug. 28, 1962
3,116,982	McIlvaine -----	Jan. 7, 1964