

# March 2016 Gas Meter Clearances and Service Installation Requirements

Call PSE's Customer Construction Services 1-888-321-7779 or visit [PSE.com/CustomerConstruction](http://PSE.com/CustomerConstruction) for more information.



## Builder/Owner/Developer Requirements

- ◆ The clearances in this handout also apply to features on buildings adjacent to the building where the gas meter is located.
- ◆ Final grade of the service line route must be in place before the service line can be installed.
- ◆ If you are unable to meet the meter location requirements in this handout, contact PSE for further assistance.
- ◆ Puget Sound Energy reserves the right to designate gas meter locations so that they comply with PSE standards.
- ◆ For gas meter installations in Cle Elum and west of Cle Elum within Upper Kittitas County, see the **Gas Meter Protection from Snow and Ice in Snow Country** handout (Form 3736).



## Gas Meter Locations

Locate gas meter on the **front wall**, or **within the front 1/3 of the side wall**, observing the corner clearance requirements detailed below.

The area 3 feet in front of and 2 feet to either side of the meter set assembly must be free of any landscaping (bushes, fences, etc.) and other structures that restrict access to the meter set assembly.

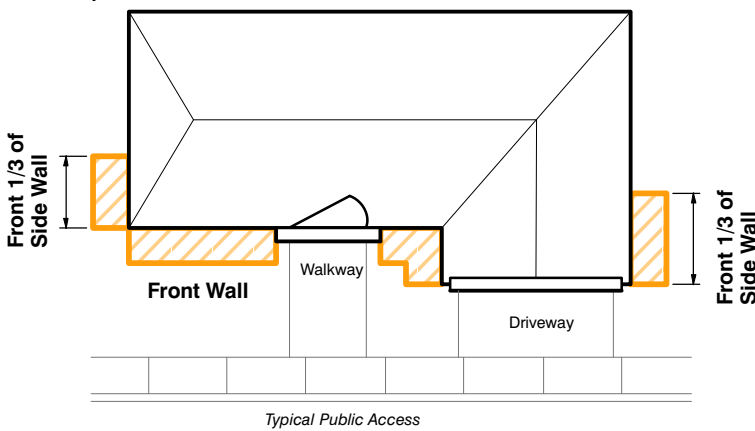

## Gas Meter Clearances to Finish Grade (250 Meter Shown)

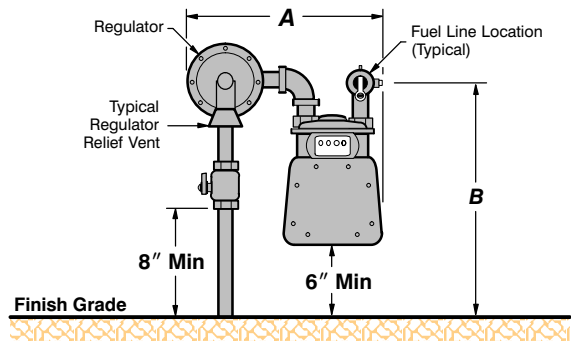

Meter Type	A Meter Width (Typical)	B Fuel Line Height (Typical)	Meter Outlet Diameter
250	16"	32" to 36"	1"
425	24"	42" to 46"	1-1/4"
630	30"	42" to 46"	1-1/4"
1000	32"	46"	1-1/4"



## Measuring Around a Building Corner

### Outside Corners

- ◆ The regulator relief vent (see diagram above) should be at least 12" from any outside corner.
    - If the regulator relief vent is at least 12" from any outside corner, then there are no minimum clearances to features around the corner.
    - If the regulator relief vent is less than 12" from any outside corner, then the minimum clearances specified in this handout must be maintained.
- Measure as if using a string.*

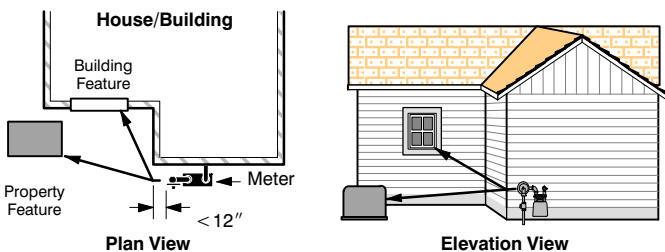

### Inside Corners

- ◆ Clearance distances from the regulator relief vent or meter set assembly to the feature must be maintained in accordance with this handout. *Measure as if using a string.*

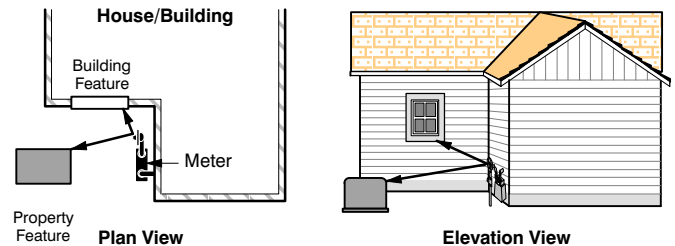



# Property Line Work Pit for Customer-Provided Trench and Backfill

## Work Pit Dimensions

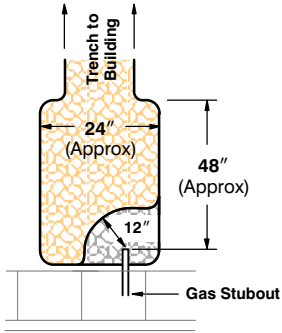

## Work Pit Cross-Section

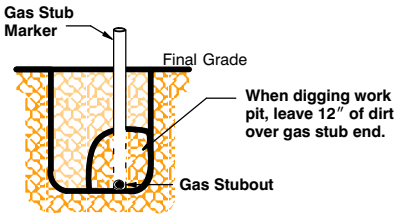

## 1/2 Yard Bedding and Shading Sand

Sand shall be provided on-site by the customer and placed within hand-shoveling distance to the work pit for bedding and shading of direct-buried facilities. A larger work pit may require more sand (see backfill requirements in this handout). Sand shall be washed, clean, and free of debris or rocks larger than 1/4 inch.

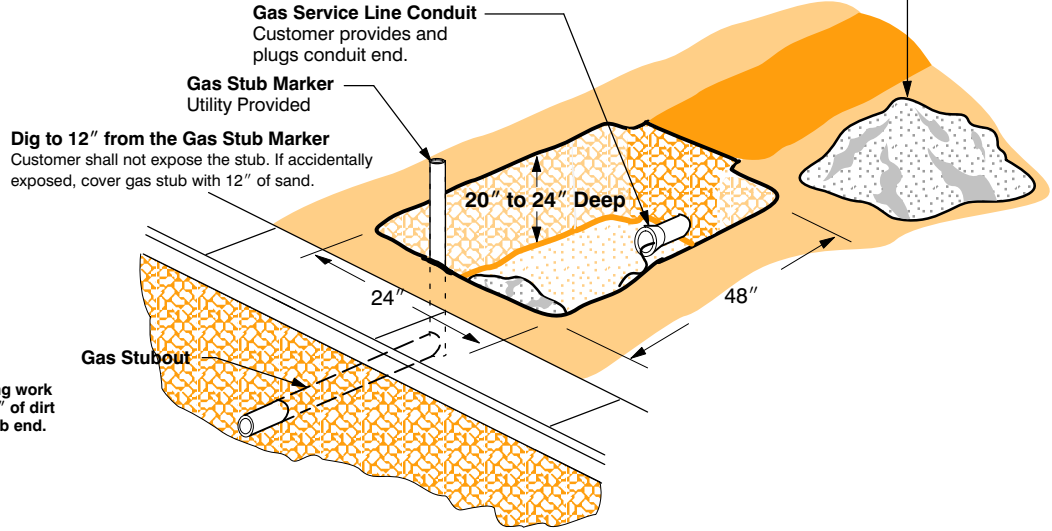

# Service Line in Conduit Installations

## Gas Service Line in Conduit Installation

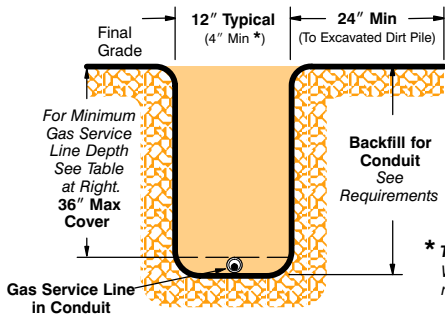

For separation requirements to other Utilities see Page 2 of the Gas and Electric Underground Service Installation Requirements handout (Form 3061)

**\* TRENCH WIDTH EXCEPTION:**  
When converting existing construction the minimum trench width acceptable is 4".

## Backfill Requirements for Conduit Installations

- ◆ **Backfill for Conduit:** Soil that is free from construction debris, glass, sharp rocks, frozen clods, and rocks larger than 10" in diameter.
- ◆ **Shading:** None required above conduit.
- ◆ **Bedding:** None required below conduit.

## Gas Service Line Depth Table for Conduit and Direct-Buried Installations

Gas Service Type	Gas Service Pipe Size	Minimum Depth of Cover over Gas
Residential	Any Size	18"
Commercial/Industrial	1-1/4" +	24"
Any Service in Snow Country (See Form 3736)	Any Size	24"



# Service Line Direct-Buried Installations

## Gas Service Line Direct-Buried Installation

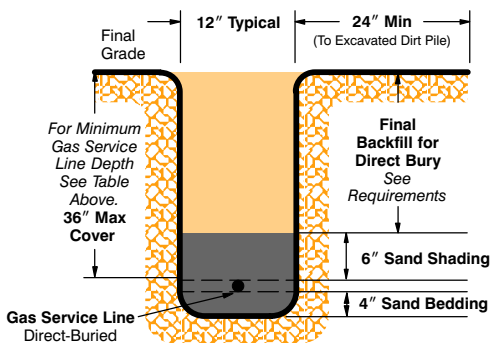

For separation requirements to other Utilities see Page 2 of the Gas and Electric Underground Service Installation Requirements handout (Form 3061)

## Backfill Requirements for Direct-Buried Installations

- ◆ **Final Backfill For Direct Bury:** The backfill layer above the sand shading shall be soil that is free from construction debris, glass, sharp rocks, frozen clods, and rocks larger than 8" in diameter.
  - If the final layer contains rocks larger than 8" in diameter, then 12" of shading shall be placed over the gas service.
  - Rocks larger than 10" in diameter are **not** permitted in the final backfill.
- ◆ **Sand Bedding:** The customer shall provide and install clean sand to a depth of 4 inches prior to gas service pipe installation. See diagram at left.
- ◆ **Sand Shading:** The customer shall provide additional clean sand in piles that are readily accessible near the trench. This shading sand is to be installed by the PSE crew after direct-buried gas line installation. Enough sand shall be provided so that the installation can be covered to a depth of 6 inches. See diagram at left.
- ◆ If customer-owned facilities will be included in the trench, please contact PSE or local power company directly for clearance requirements.



## Meter and Service Connections Work Pit

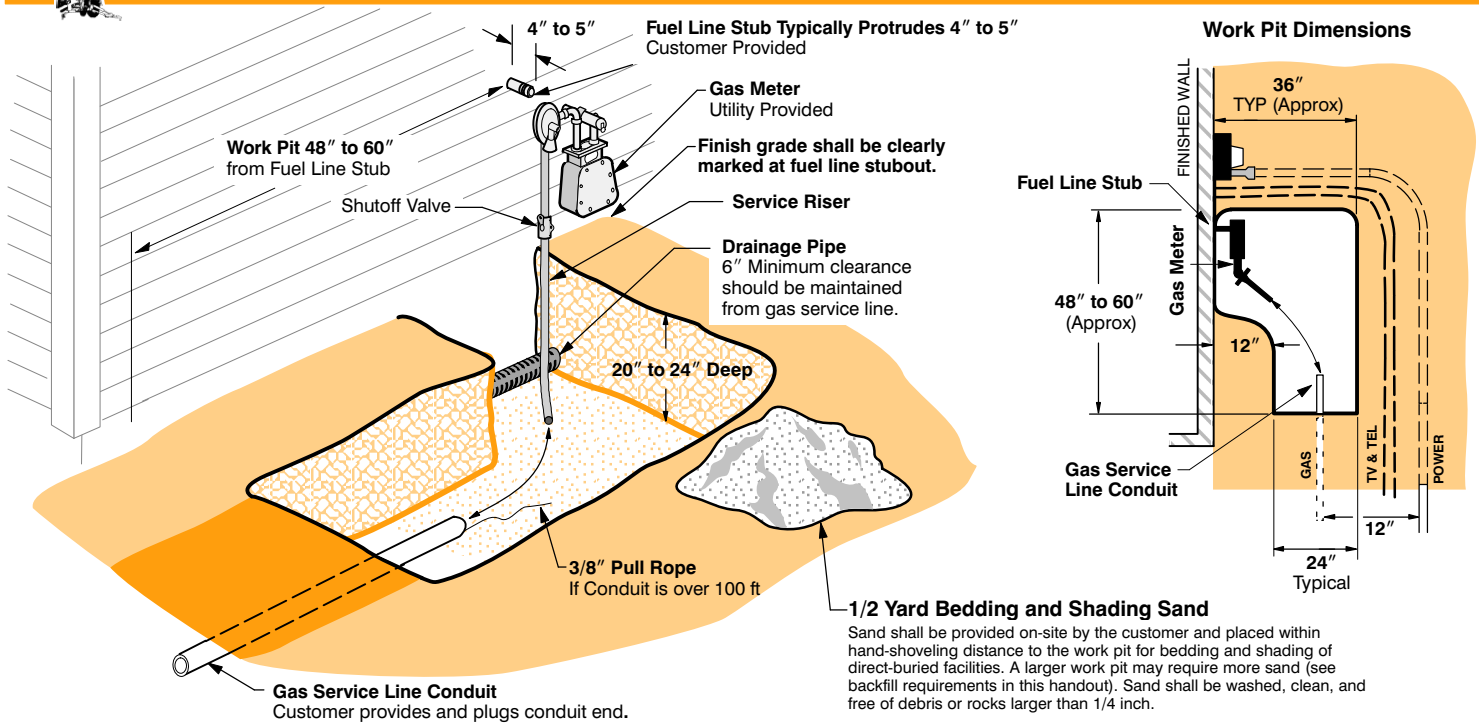

## Conduit Requirements for Gas Service

- ◆ PSE **recommends** the use of conduit for all gas service installations.
- ◆ **Conduit Installation Requirements**
  - ❑ Gas conduit runs over 100 feet long must have a 3/8-inch minimum diameter pull rope installed.
  - ❑ Conduit bends shall be one long radius, single-piece sweeps (see table below). Fittings and elbows shall not be used because the joints prohibit service insertion.
  - ❑ The sum total of the degrees of bends in the conduit run cannot exceed 180°.
  - ❑ Conduit shall not cross in the trench.
  - ❑ Yellow or white Schedule 40 PVC conduit used for gas service lines shall not be marked "water," or any other utility.

Service Line	Conduit Size, Type, & Color	Min. Bend Radius
Typical Residential $\leq 185'$	2" (minimum) Schedule 40 Yellow or White PVC	36"
Typical Residential Services $>185'$ and $\leq 1000'$	3" (minimum) Schedule 40 Yellow or White PVC	48"
Typical Residential $> 1000'$	4" (minimum) Schedule 40 Yellow or White PVC	60"
Typical Large Multi-Family & Commercial Services	4" (minimum) Schedule 40 Yellow or White PVC	60"

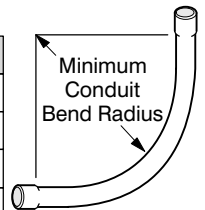

## Preferred Trench Location When the Trench Must Pass Near Trees

The preferred position for customer-provided trenching is as far as possible outside of the dripline of trees. If this is not possible, contact PSE's Customer Construction Services at 1-888-321-7779 for trench location and depth requirements.

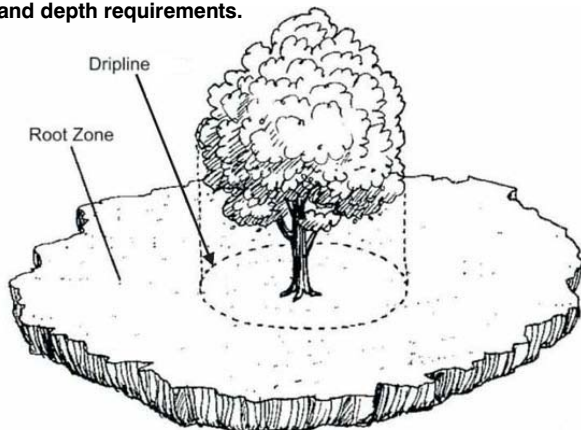

**Know what's below.  
Call before you dig.**



# Regulator Relief Vent Clearances from Building Features

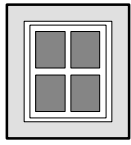

Window Opening



Attic Vent Opening



Crawl Space or Garage Vent Opening



Soffit Vent Opening

Clearance Zone

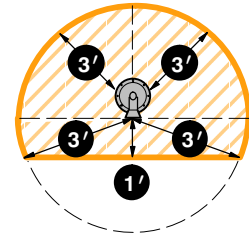

Clearance Zone from Windows, Building Vents, and Fireplace Cleanouts

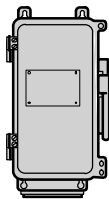

Power Disconnect

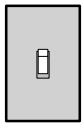

Wall Switch

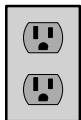

Electric Outlet

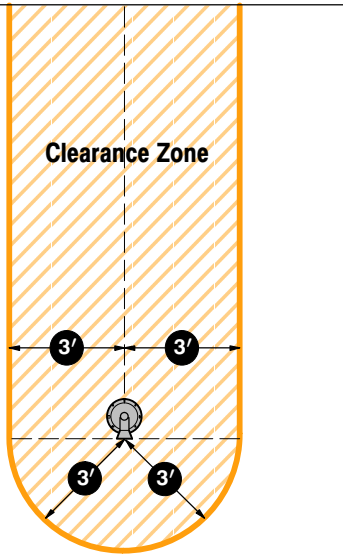

Clearance Zone from Electrical Components

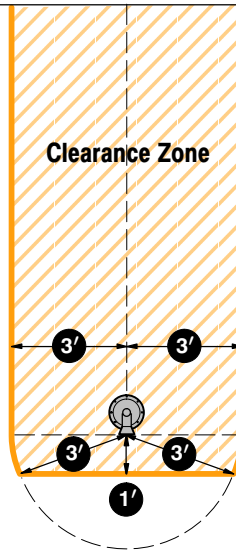

Clearance Zone from Doors and Garage Doors

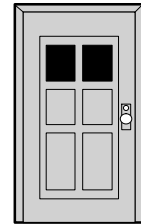

Doors

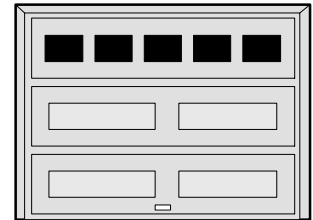

Garage Doors

## Mechanical Air Intake Features at Clearance Distance A (10 feet)

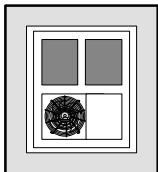

Window/Wall-Mounted Fan

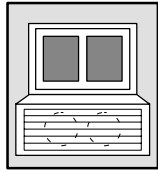

Window-Mounted Air Conditioner

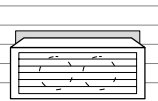

Wall-Mounted Air Conditioner

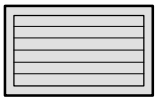

Mechanical Air Intake Opening

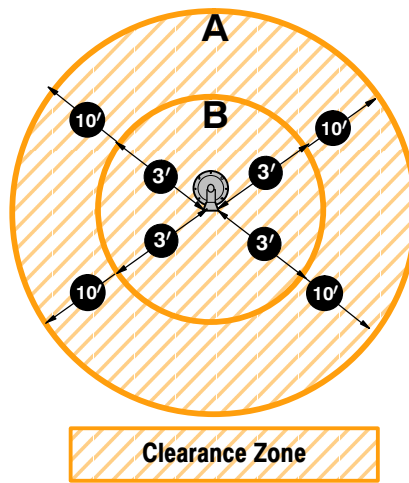

Clearance Zone

## Appliance Intake and Exhaust Features at Clearance Distance B (3 feet)



Bathroom Fan Vents



Fireplace Cleanout Opening



Dryer Intake/Exhaust

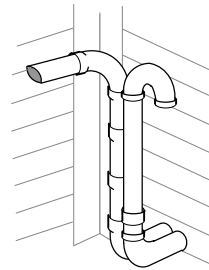

Furnace Air Intake/Exhaust

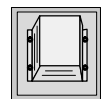

Fireplace Air Intake/Exhaust

Clearance Zones from Wall-Mounted Fans and Air Conditioners, and Appliance Vents and Intakes



## Gas Meter Clearances from Building Features

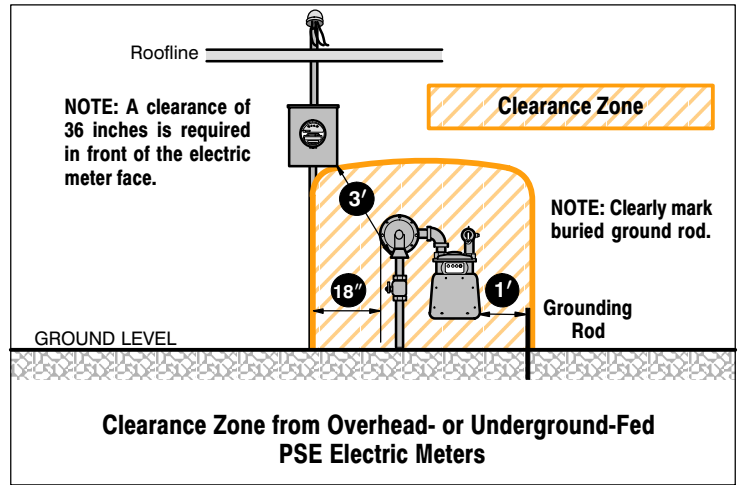
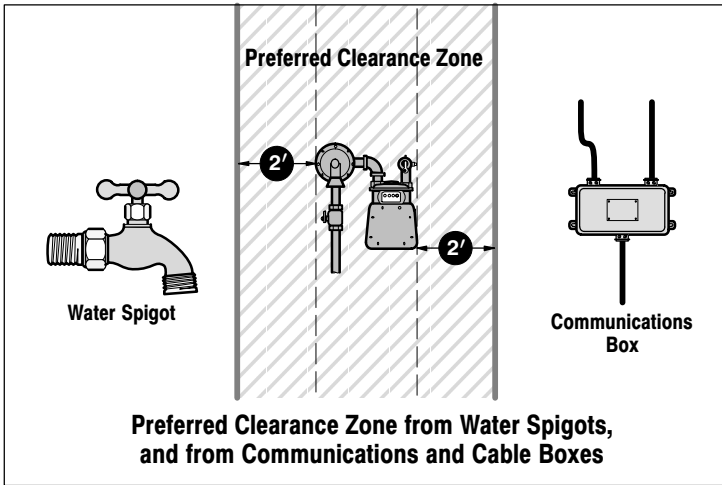
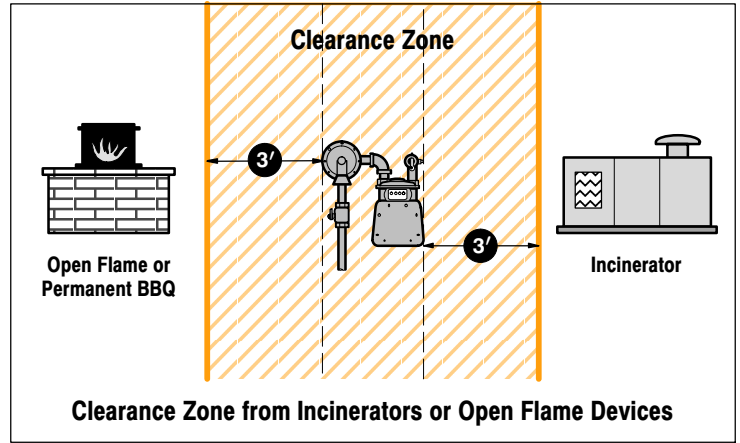
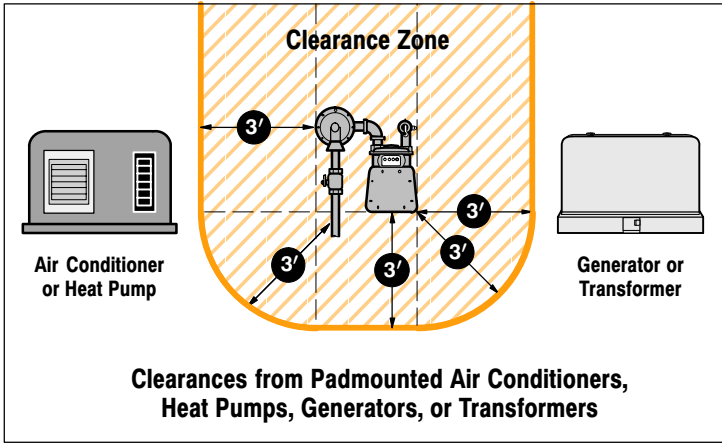

## Gas Meter Clearances Under Porches, Decks, and Balconies

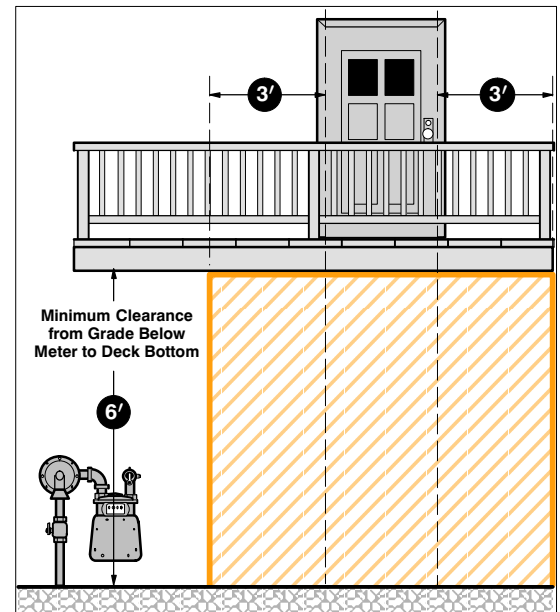
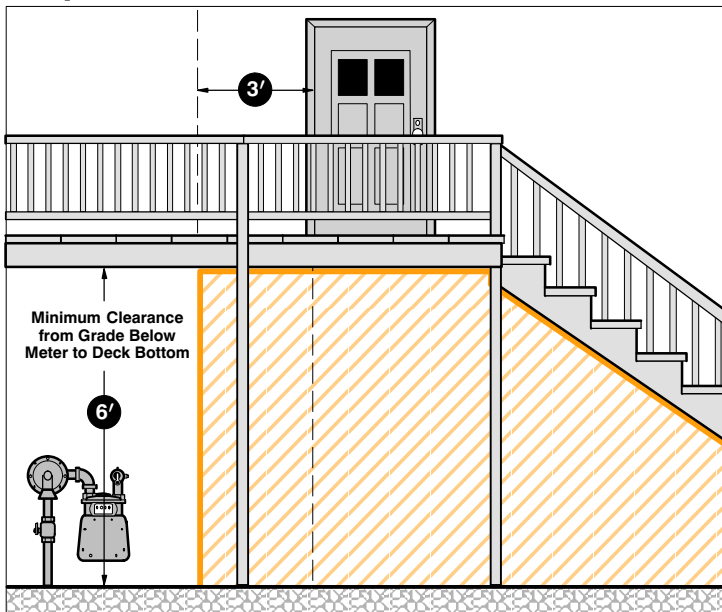



## Guard Post Installation (PSE's Responsibility)

- ◆ To protect meter set assembly from vehicle damage, PSE will install guard posts when required.
- ◆ To avoid the need for PSE to install guard posts, choose a meter location that is away from driveways or other areas where vehicles travel.
- ◆ Guard post requirements are based on the following factors:
  - ❑ Existing barriers (curbs, guard rails, steep increases in grade, ditches, rockeries, trees, shrubs, chimneys, recessed walls, etc.), which will provide adequate protection;
  - ❑ Proximity of the facility to the edge of the travel lanes;
  - ❑ The expected speeds in the travel lanes;
  - ❑ The width of the travel lane;
  - ❑ The volume of vehicle traffic;
  - ❑ Existing nearby building damage or other indicators of vehicle damage that may have already occurred; and,
  - ❑ The type of customer (i.e., single-family residential versus commercial/industrial or multifamily).
- ◆ In cases where a meter set assembly will be installed behind a curb, observe the following:
  - ❑ If the curb will be a rolled curb, and if there is less than 10 feet of space between the curb and the meter, guard posts will be installed; and,
  - ❑ If the curb will have a vertical face, and if there will be less than 5-1/2 feet between the curb and the meter, guard posts will be installed.
- ◆ Guard posts will be painted "caution" yellow, especially those located in commercial or industrial locations, street rights-of-way, and alleyways.

### Typical Single-Family Guard Post Installation

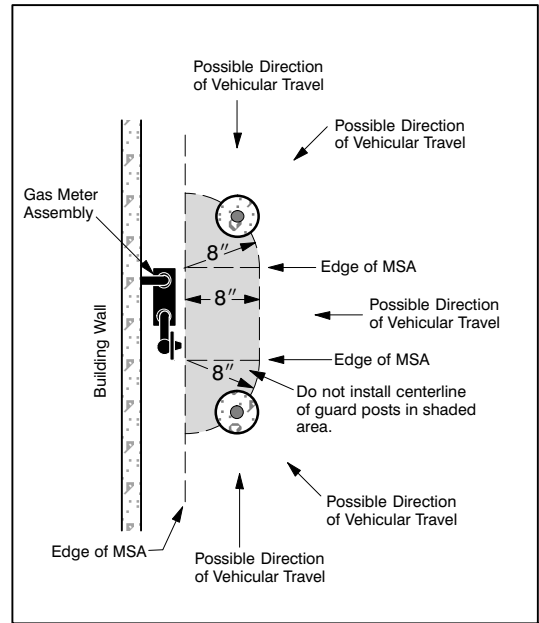
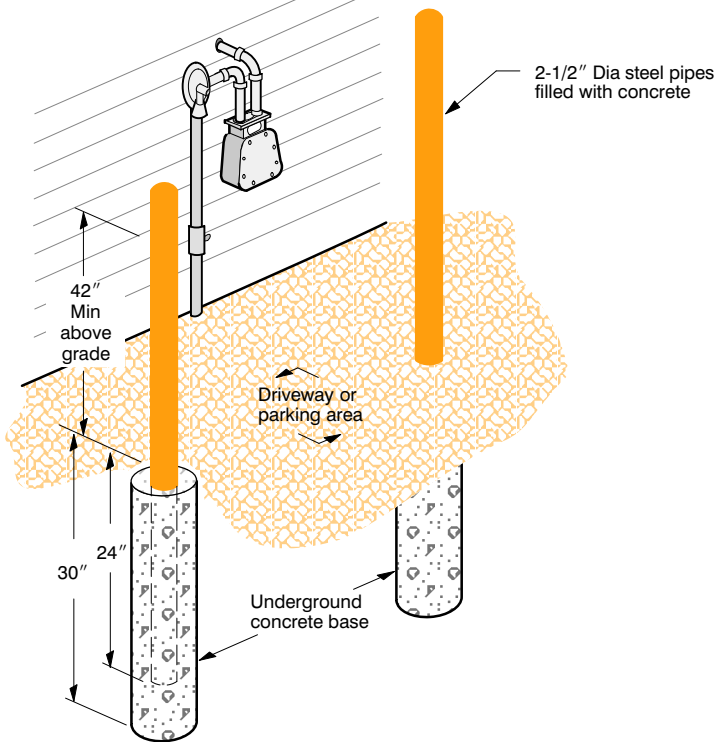

**TOP VIEW EXAMPLE OF GUARD POST LOCATIONS THAT PROVIDE PROTECTION FROM ALL POSSIBLE DIRECTIONS OF VEHICULAR TRAVEL**

	Single-Family Residence	Commercial/Industrial or Multi-Family	Legal Speed Limit Greater than 35 MPH
<b>Guard Post <sup>1</sup></b>	2-1/2" Dia.	4" Dia.	6" Dia. <sup>2</sup>
<b>Concrete Base <sup>3</sup></b>	8" Dia. x 30" High	15" Dia. x 30" High	30" Dia. x 42" High <sup>4</sup>
<b>Minimum Clearance between Meter Set Assembly &amp; Guard Post <sup>5</sup></b>	8"	12"	12"

1 Guard posts shall be made from steel pipe, 6 feet long, filled with wet concrete and domed on top.  
 2 In this installation, the guard post can be solid concrete 9 inches in diameter.  
 3 At least 24 inches of the guard post shall be embedded in the base, with at least 42 inches of the post above final grade.  
 4 In this installation, at least 26 inches of the guard post shall be embedded in the base, with at least 42 inches of the post above final grade.  
 5 Additional guard posts are required if the centerline spacing between guard posts exceeds 36 inches. The additional guard posts are typically evenly spaced between the outer two posts.