8 Spring water tapping

Andrew Tayong

8 Spring water tapping

8.1 Introduction

Springs are found mainly in mountainous or hilly terrain. A spring may be defined as a place where a natural outflow of groundwater occurs.

Spring water is usually fed from a sand or gravel water-bearing soil formation called an aquifer, or a water flow through fissured rock. Where solid or clay layers block the underground flow of water, it is forced upwards to the surface. The water may emerge either in the open as a spring, or invisibly as an outflow into a river, stream, lake or the sea (Fig. 8.1). Where the water emerges in the form of a spring, it can easily be tapped. The oldest community water supplies were, in fact, often based on springs and they remain a favoured source, because the water usually has a high natural quality and intake arrangements are relatively straightforward. That suits both the engineers helping to design the water supply system, and the community members who will have to look after it. Because of their popularity, most natural springs have been developed in one way or another as drinking water sources. However, a proper feasibility study, application of some basic design principles and vigilance in protecting the spring and its catchment area will usually lead to improvements in the quantity, quality and sustainability of many such supplies. As in the rest of the book, there is an overriding principle that community members should be fully informed and closely involved in decisions about the tapping, use and protection of spring water sources.

A key reference on spring catchment is the SKAT manual *Spring Catchment* of 2001.

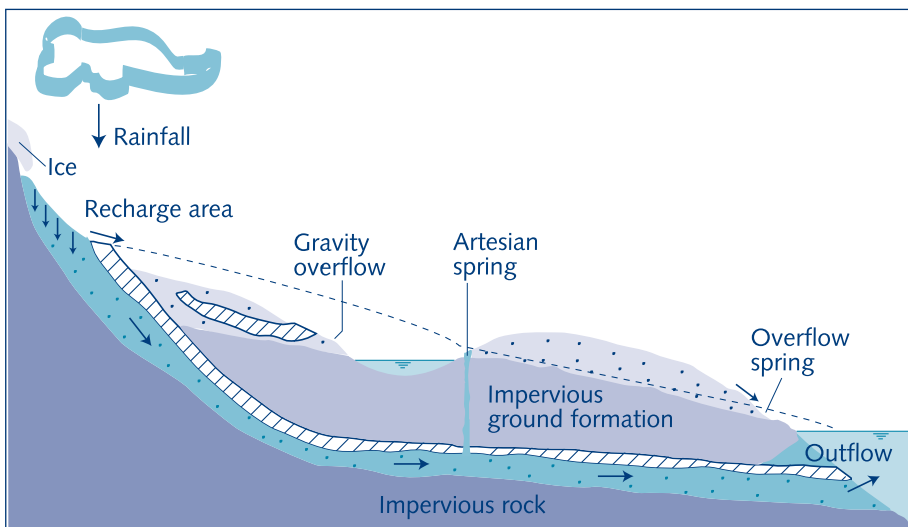

Fig. 8.1. Occurrence of springs

8.2 Identification of spring source

Local people, especially women (as drawers of water), but also farmers, hunters and grazers, have a good knowledge of the location of springs and their characteristics. These people are the primary sources of information in the identification process. In the dry season, green vegetation in a dry area may also be an indication of a spring source.

Some springs form small ponds where animals drink and people may well also scoop water from there. Others flow as small streams in valleys and can be traced back to the source. The source, though, is not necessarily the first upstream point at which the stream emerges from the ground. In some cases streams may be buried for quite a length and there can be added risks of contamination unless the investigation continues further upstream to locate the true spring.

8.3 Types of spring sources

Springs are classified according to the conditions under which water flows to them. Some surface under pressure, while others do so as a result of discontinuities in the strata that held the water underground. For instance, in a seepage or filtration spring the water percolates from many small openings in porous ground, while in fracture springs the water comes from joints or fractures in otherwise solid rock, and for tubular springs the outflow opening is more or less round. To understand the possibilities of water tapping from springs, the distinction between gravity springs and artesian springs is most important. A further sub-division can be made into depression springs and overflow springs.

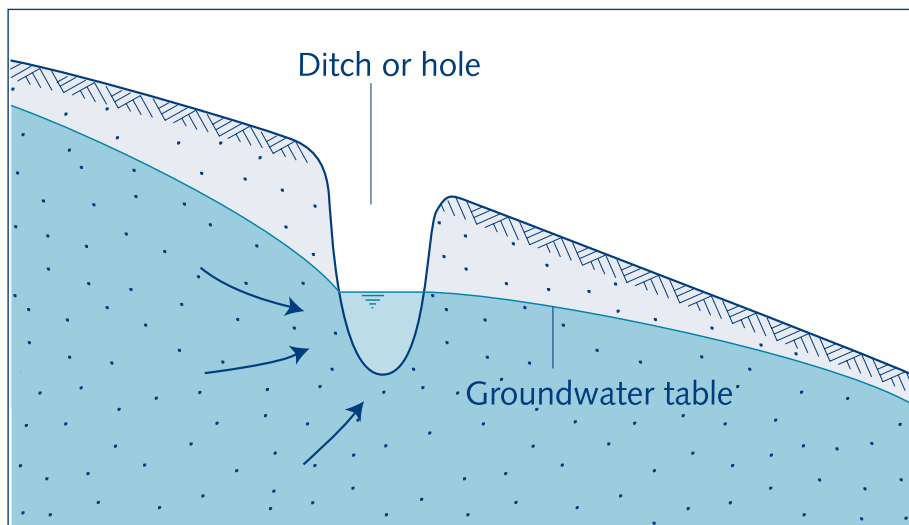

Fig. 8.2. Gravity depression spring

Gravity depression springs

Gravity springs occur in unconfined aquifers. Where the ground surface dips below the water table, any such depression will be filled with water (Fig. 8.2).

Gravity depression springs usually have a small yield and a further reduction occurs when dry season conditions or nearby groundwater withdrawals result in the lowering of the groundwater table.

Gravity overflow springs

A larger and less variable yield from gravity springs is obtained where an outcrop of impervious soil, such as a solid or clay fault zone, prevents the downward flow of the groundwater and forces it up to the surface (Fig. 8.3). At such an overflow spring, all the water from the recharge area is discharged. The flow will be much more regular than the recharge by rainfall. Even so, an appreciable fluctuation of the discharge may occur and in periods of drought some springs may cease to flow completely.

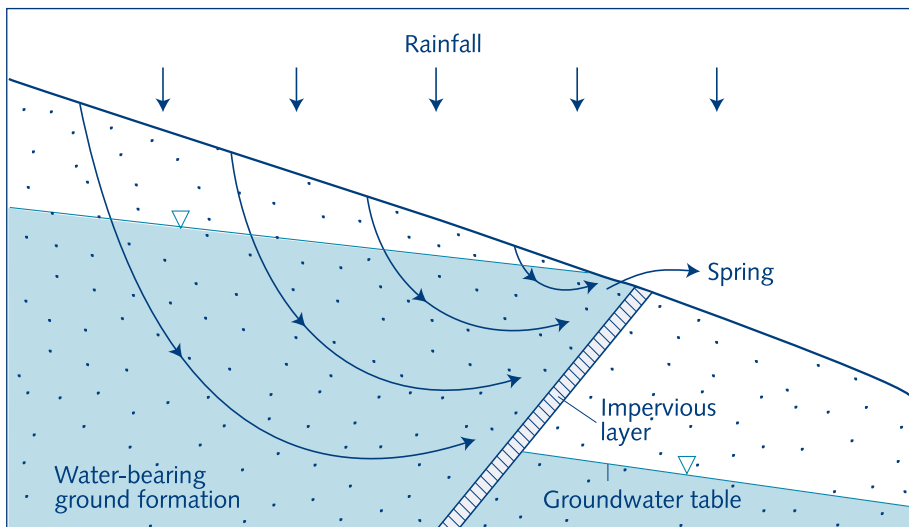

Fig. 8.3. Gravity overflow spring

Artesian depression spring

Artesian groundwater is prevented from rising to its free water table level by the presence of an overlying impervious layer. That is the reason why artesian groundwater is under pressure. Artesian springs are the sites where the groundwater comes to the surface.

Artesian depression springs are similar in appearance to gravity depression springs. However, the water is forced out under pressure so that the discharge is higher and there is less fluctuation. A drop of the artesian water table during dry periods has little influence on the artesian groundwater flow (Fig. 8.4).

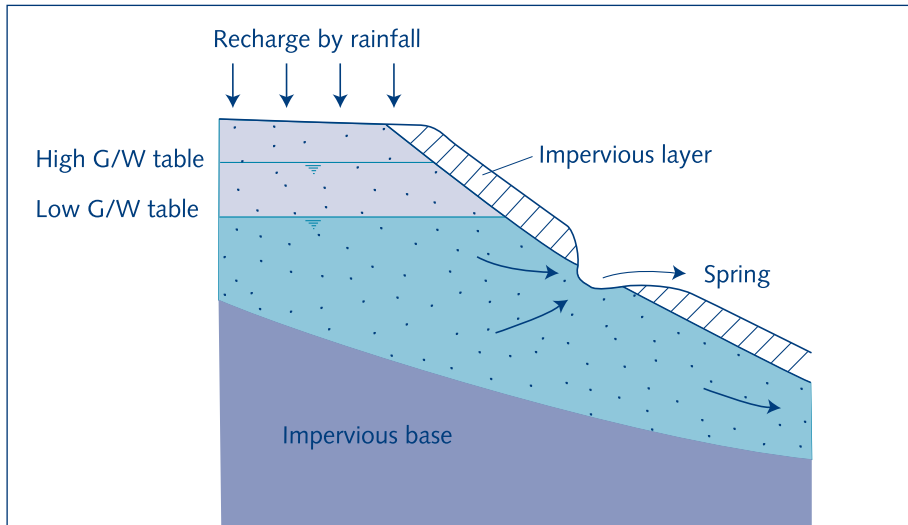

Fig. 8.4. Artesian depression spring

Artesian fissure spring

Artesian fissure springs (Fig. 8.5) form an important variant of this type of spring. Again the water emerges under pressure, this time through a fissure in the impervious overburden. Fissure springs exist in many countries and are widely used for community water supplies.

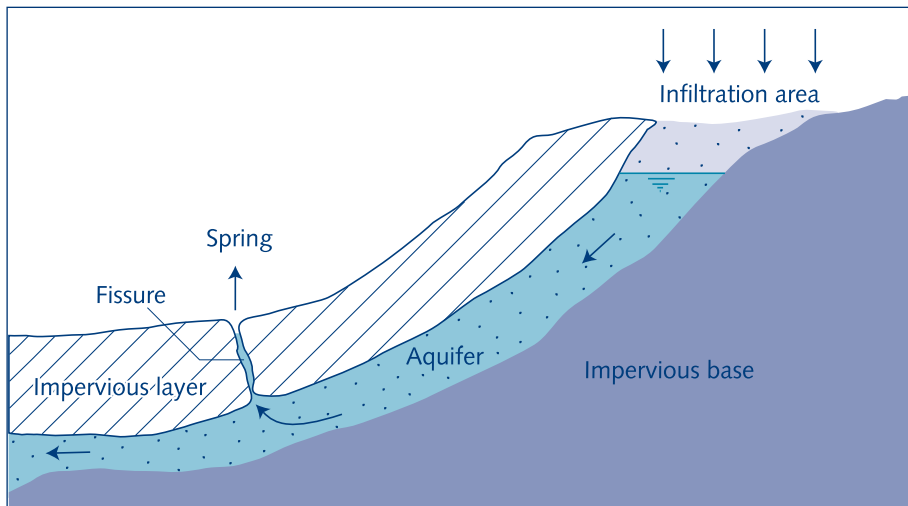

Fig. 8.5. Artesian fissure spring

Artesian overflow spring

Artesian overflow springs often have a large recharge area, sometimes a great distance away (Fig. 8.6). The water is forced out under pressure; the discharge is often considerable and shows little or no seasonal fluctuation. These springs are very well

suited for community water supply purposes. Artesian springs have the advantage that the impervious cover protects the water in the aquifer against contamination. The water from these springs is usually bacteriologically safe.

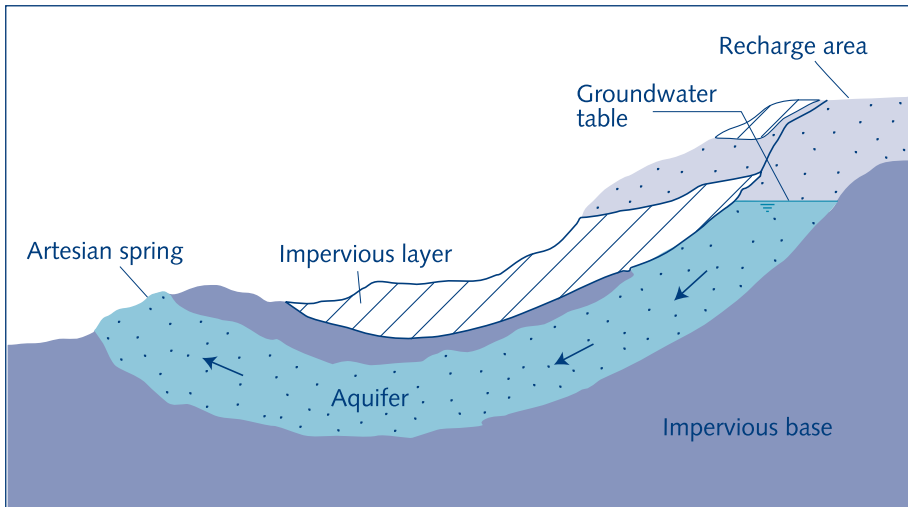

Fig. 8.6. Artesian overflow spring

8.4 Feasibility study

The feasibility study of a spring source aims to investigate the quality and the quantity of water from the source. It provides the information and data for design of a water supply system. The study also needs to take any possible environmental impact into consideration. Local people are important sources of information and should be involved in decisions about the feasibility of developing any particular spring. Aspects to be considered include the quantity and quality of the water, its reliability, current and future uses, and socio-cultural acceptability for a domestic water supply. A representative feasibility study is therefore best done together with a team of community members.

Rapid environmental assessment

A rapid assessment of potential environmental impact is a sensible first step. This involves identifying possible environmental consequences of developing a spring. These can include risks of landslides, erosion, or contamination of the source. The environmental assessment includes investigating the flow direction of surface run-off above the spring; human activities and water uses in the catchment area, i.e. habitation, farming, grazing, etc.; and the type of plants growing in the catchment or recharge area.

If there are people living in the catchment/recharge area, they are likely to contaminate the groundwater through their own waste and their activities such as cattle holding or

agriculture using artificial fertilizer or chemicals. But it may be very difficult to relocate them. If the groundwater contamination risks are too high, then such locations are not suitable. Some trees and plants are undesirable too. Eucalyptus trees, for instance, compete for water with the spring and can significantly reduce the yield. Raffia palms, though harmless, increase the iron content of the water, changing its taste and colour enough to deter consumers. If these kinds of plants are around, the best solution is to make the community members aware of the repercussions and hold discussions about moving or removing them.

Spring water quality

In general, spring water is of good quality. Pathogenic contamination is unlikely if the source meets certain criteria. These include the thickness of the soil layer, the type of soil and the velocity of infiltration of the surface water. The soil formation should be thick enough for natural filtration and biological action to remove pathogenic organisms before the water enters the aquifer feeding the spring. The type of soil determines the speed of the flow through the voids in the soil and so influences the purification mechanisms and the concentration of suspended solids. If the soil layer is not thick enough, any human activity should be restricted or even forbidden in the catchment area. Otherwise, local farmers may be allowed to conduct some agricultural activities in the catchment area (but outside the protection area around the spring) under some restrictions such as no use of artificial fertilizers or harmful chemicals. This may contribute to the protection of the catchment because they have a direct interest in protecting the area for their crop and their water supply.

One of the key signs of a good spring is that the water maintains a constant temperature throughout the day. This temperature is just below the average air temperature. The water should also be colourless. Variation of water temperature during the day and colouration of water shortly after rains are indications of a poor quality spring source. It may have its water-bearing soil layer not deep enough or rapid infiltration of surface water through the topsoil.

If users note these temperature and colour changes, but they still favour the spring over alternative water sources, then the community needs to be advised to include water treatment as part of the water supply system. This treatment may be incorporated in the intake chamber or outside the spring. For small communities, household-based water treatment may be the most feasible option.

Laboratory testing of the water quality is a necessary part of the feasibility study even if there are no changes in the water temperature and colour. Testing should extend over a reasonable period of time, especially if there are human activities in the recharge area of the source.

The spring water quantity

The quantity of water a spring produces is known as its yield. Information about the yield is crucial in the decision-making process for the tapping of a spring. Yield is studied in terms of flow rate and consistency. Variation in the yield of a spring during the dry season and the rainy season is an important criterion to determine whether the spring is a suitable source. If the ratio between the highest yield in the rainy season and the yield in the dry season is below 20, then the spring has an acceptable consistency and can be regarded as a reliable source in both wet and dry seasons. Take into account that the highest and the lowest yield do not occur at the beginning of the rainy season and at the end of the dry season but typically a couple of weeks (or even months) later, depending on the soil characteristics.

It follows that a proper feasibility study of a spring source should last for at least one year. A longer duration is preferred as there may be dry and wet years. The study will indicate the variation in yield of the spring throughout the year, and the maximum, minimum and estimated average flow. The average yield will reveal if more than one spring is needed to meet the daily water demand of the user population. If the overall yield is limited, users should be guided towards using the spring water primarily for drinking and cooking because of quality, and secondarily for other domestic purposes. A participatory study increases the people's sense of ownership and the appreciation for proper water management.

The yield is highly influenced by the water storage capacity of the aquifer. When the water velocity in the saturated stratum gets too high, the pores through which the water passes tend to become choked so that the flow becomes considerably reduced. Limestone and volcanic rock areas do not experience this effect.

In many cases, more than one spring is tapped for the same water supply system. Ideally, this should be done in a phased manner, with the community water committee judging in advance when augmentation is going to be necessary. As the population and/or its productive activities increase, daily water demand also increases, resulting in potential water shortages in the system. Shortages will occur first during dry seasons and a few weeks or months into the rainy season. They can be prevented by proper planning with the community water committee.

There may not always be time for a long study of spring yield. Water supplies are key development indicators used by politicians in rural areas for campaign purposes. This political influence sometimes does not allow the technician and the community to study the source for the required duration. Under such influences, critical study periods are used to give a rapid estimation of the yield. The best time to use is the transition period of dry and rainy seasons when the flow is minimal. The times of peak and minimum

spring yield do not necessarily correspond to the peak and minimum rainfall periods. In fact, the lowest spring yield usually occurs about a few weeks to several months into the rainy season. So, if the study terminates at the end of the dry season, the lowest yield level of the spring may not be noticed. The "critical" study should extend for about four months into the rainy season. The chances of recording peak yield still remain unlikely, but that is less critical than the minimum yield.

Estimating spring yield

A spring yield is measured in litres per second (l/s). The measurement process involves two selected trained villagers who measure the discharge from the spring over the study period. The process starts with the construction of an earth dam. Spring water retained by the dam is drained through a pipe. One villager collects the water with a container of a known volume while the other measures the time needed to fill the container (Fig. 8.7). The pipe diameter and container size are chosen such that the water outflow will not fill the measuring container in less than five seconds. Sometimes several pipes are used. Four readings are taken during the day and day averages are calculated, expressing the discharge in l/s. This is repeated once every week for the measuring period. In this way, the minimum and maximum yields are determined.

Studies of catchments with many springs channelled into a single supply point must be carried out carefully for reasons of back-pressure effects. Simply adding the yields from each individual spring together is not enough. An excessive flow could build up a back pressure and cause some springs to divert their courses. In some cases it may lead to permanent damage to the catchment. The designer needs to study the flow characteristics of any collection chambers or pipes and ensure that each spring outlet flows freely. The yield of springs may vary from a few litres per minute to several thousands per minute.



Fig. 8.7. Measuring spring yield. Photo by Andrew Tayong

8.5 Design and construction

The design and construction of a spring-fed water supply for a specific location must (i) be appropriate for the specific local conditions, (ii) prevent pathogenic contamination and pollution, (iii) be reliable in terms of quantity, and (iv) have no adverse environmental consequences.

Because of their small yield and the difficulty of providing adequate sanitary protection, gravity depression springs (Fig. 8.2) cannot be recommended for community water supplies. The presence of such a spring, however, indicates shallow groundwater that may be withdrawn using drains or dug wells. These can be covered and protected against contamination.

Design

The major components in the design of a spring-source water supply system include the actual spring water collection area – where water from the aquifer is actually being channelled to a single discharge point – the supply pipe, the collection chamber, and the outlet to a storage tank (Fig. 8.8).

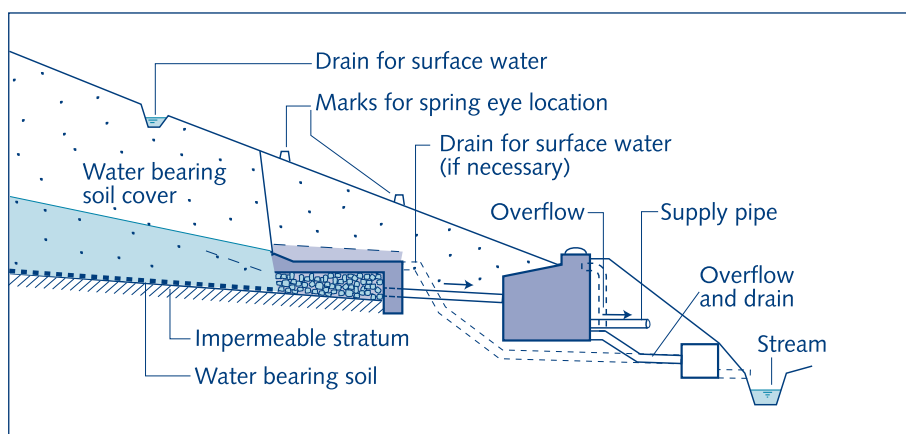

Fig. 8.8. Lay-out of a spring water collection area (Adapted from Helvetas Cameroon, 1985)

The collection area is a critical part and involves the tapping of water from the aquifer. Two methods are used to collect the groundwater. One is by dry stone masonry and the other is by perforated pipes (Fig. 8.9).

Experience has shown that roots may grow in the collection area. The roots can become so dense that they obstruct the flow, thereby reducing output from the source and also generating back pressure that could cause damage to the aquifer hydraulics. Easy access to the collection area enables the caretaker to remove the obstructing roots.

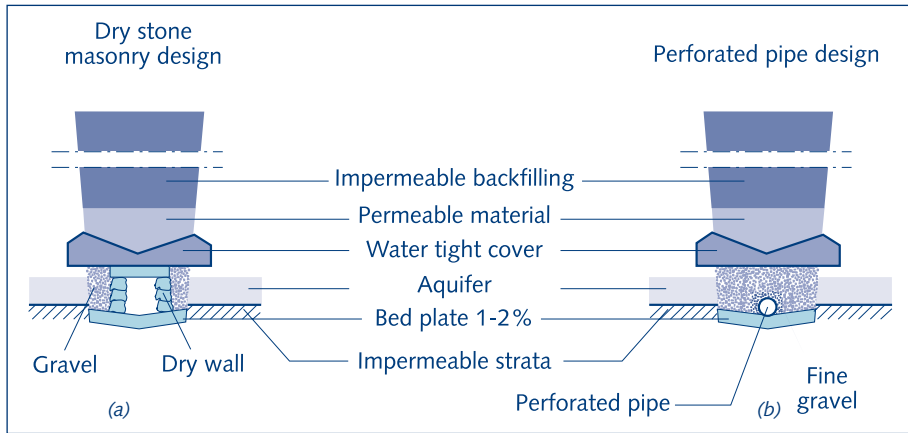

Fig. 8.9. Types of water tapping methods: (a) dry stone masonry, (b) perforated pipes
Source: Helvetas Cameroon, 1985

Other modifications in the design are made mainly to reduce costs and make the system more appropriate (fig 8.10).

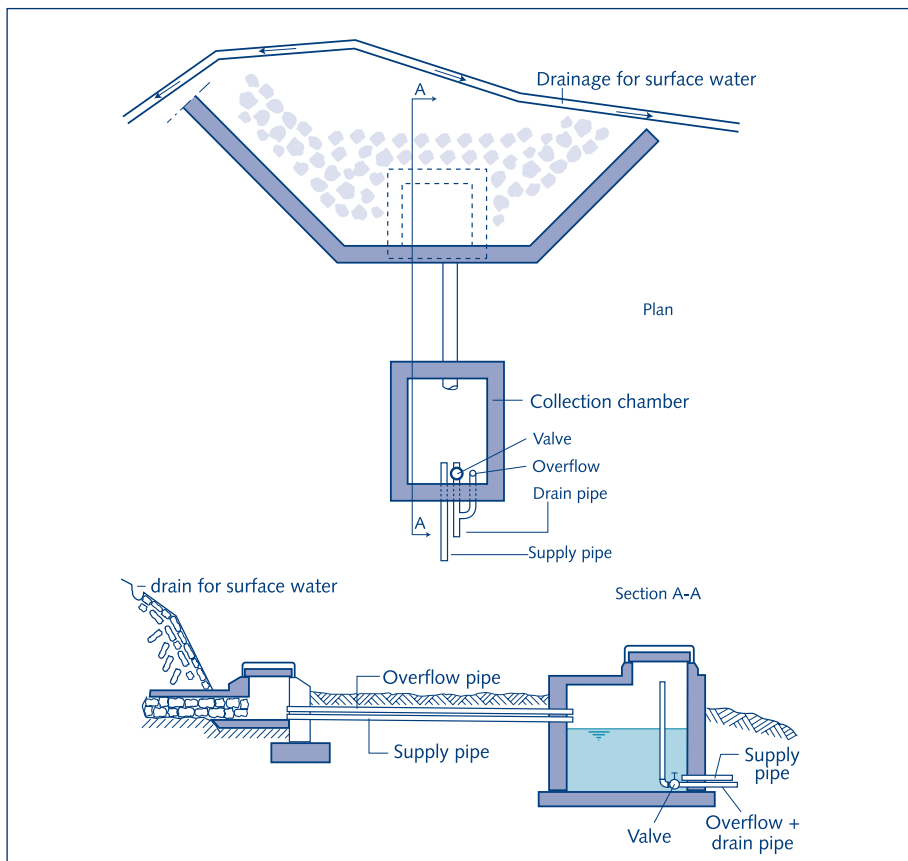

Fig. 8.10. Low cost option for collection area
Source: Helvetas Cameroon, 1985

Two supply pipes are used in the collection area to channel the drain water to the collection chamber. The first pipe channels all the discharge during times of low yield. The second ensures that there is no excess water backing up in the collection area during maximum yields, as this could obstruct the natural flow in the aquifer and create back pressure.

Tapping of gravity springs

The spring collection area is the heart of a water supply system that uses a spring source. Once constructed and backfilled, access to collection area, for instance to correct errors, is very cumbersome. Thus, care and experience is needed for proper spring construction. Figure 8.11 illustrates a detailed view of a spring collection area design.

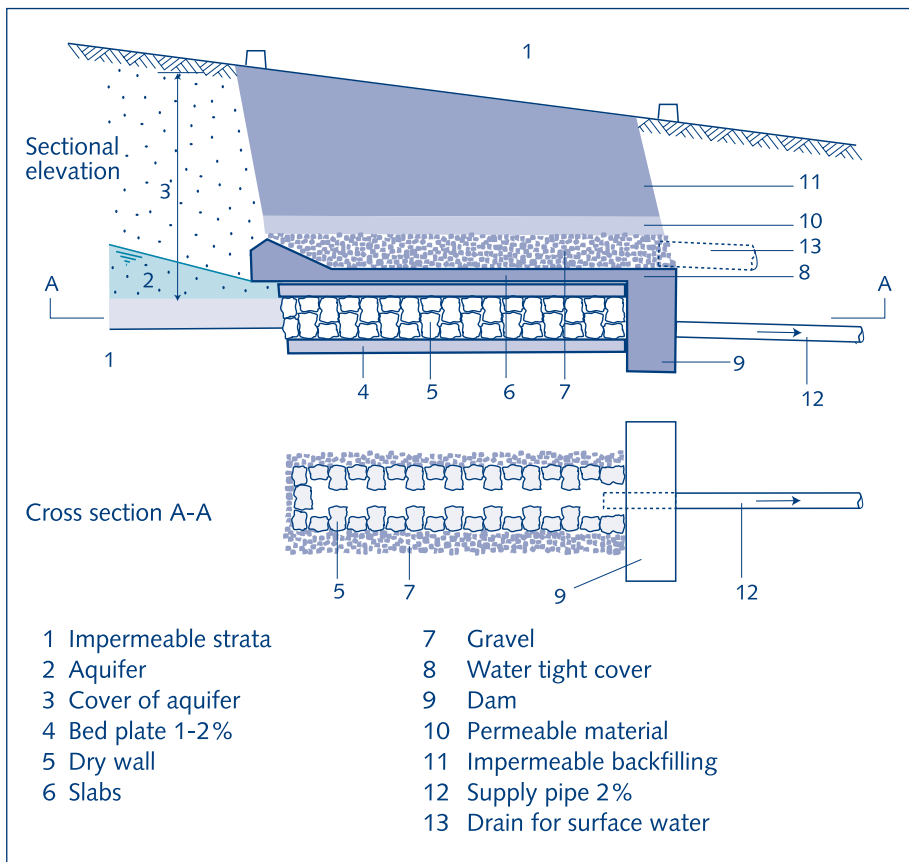

Fig. 8.11. Detailed design of a spring collection area
Source: Helvetas Cameroon, 1985

The major parts of the construction are the permeable construction and the barrage (dam). The permeable construction is a package of filter material made of rocks, stones and gravel that allows water to drain into the supply pipes. Perforated pipes surrounded by a gravel filter package are sometimes used instead of dry stone masonry but the

latter is preferable. The barrage can be a concrete dam or a stone masonry construction controlling the drain and directing water into the supply pipes. It also carries the load of the backfilling. The floor of the permeable construction and the perforated pipes slopes at about 2%.

Construction of the collection chamber should take into consideration that it acts as a sedimentation tank as well. Thus, access must be provided for regular cleaning.

Construction starts with excavation from where the spring emerges to the surface. This is done carefully to avoid disturbing the natural flow of water from the spring. There should be regular drainage during the digging. Decreasing flow during the digging is an indication of different springs from different directions. In such a case, digging should be extended to catch all the springs (Fig. 8.12).

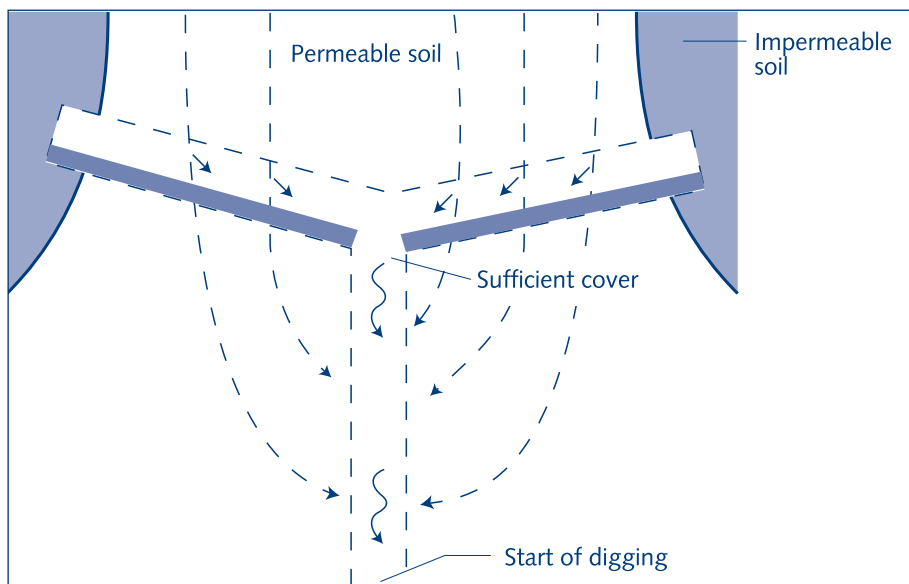

Fig. 8.12. Excavation of gravity spring source
Source: Helvetas Cameroon, 1985

Tapping artesian springs

In outward appearance, artesian depression springs are quite similar to gravity depression springs but their yield is greater and less fluctuating, as the water is forced out under pressure. Excavation and construction of artesian springs are as shown in figure 8.13.

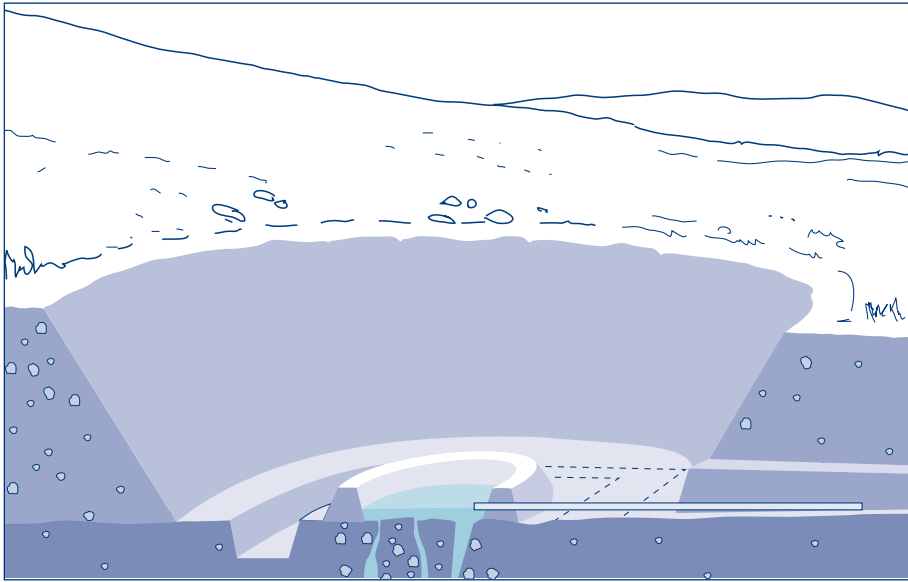

Fig. 8.13. Excavation and construction of artesian springs
Source: Meuli and Wehrle, 2001

To tap water from an artesian depression spring, a wall extending a little above the maximum level to which the water rises under static conditions should surround the seepage area. For sanitary protection the spring collection area or spring "eye" should be covered (Fig. 8.14).

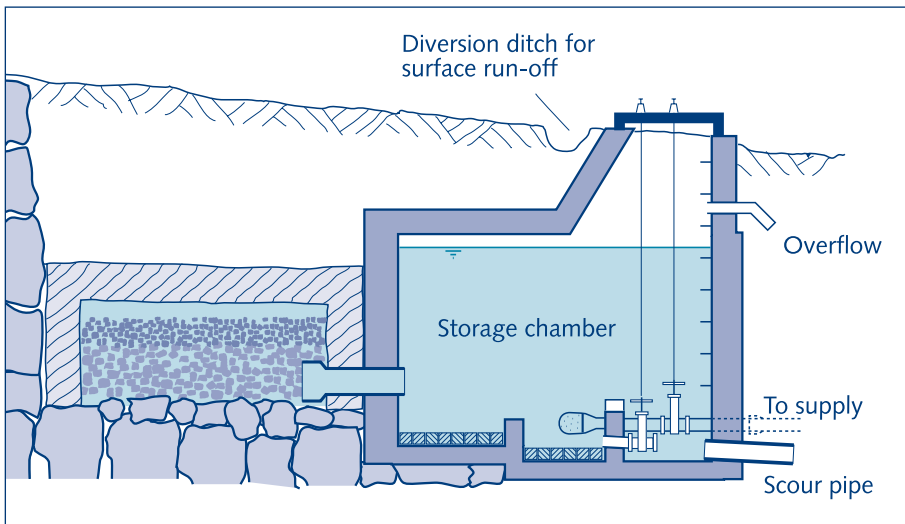

Fig. 8.14. Artesian depression spring

For artesian depression springs that cover a large area, a system of drains is commonly used to channel the collected water into a storage chamber. From there it flows into the water supply system. To protect the water quality, the recharge area should be cleared and kept clear of all debris. For granular top layers, it may be necessary to cover the recharge area with layers of graded gravel to trap fine suspended solids.

Fissure springs are similar to artesian depression springs, but the water rises from a single opening, so that the intake works can be small (Fig. 8.15). Some increase in capacity may be obtained by removing obstacles from the mouth of the spring or by enlarging the outflow opening (Fig. 8.16). The localised outflow of water from the spring makes sanitary protection easy to arrange.

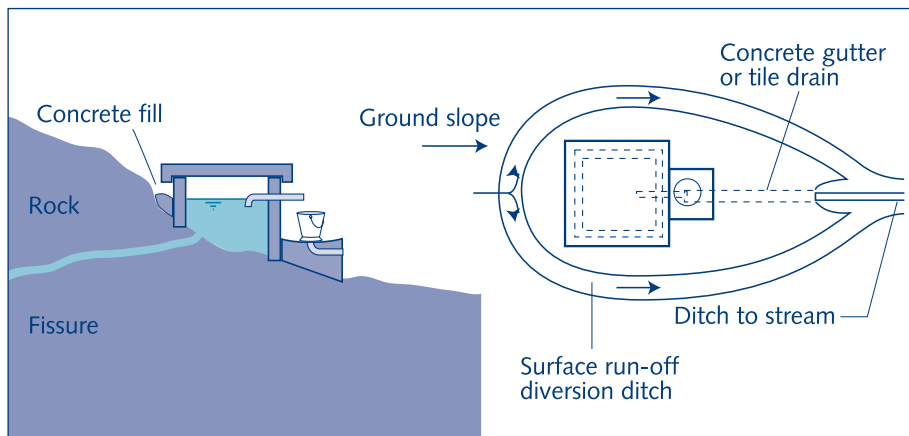

Fig. 8.15. Fissure spring of small capacity

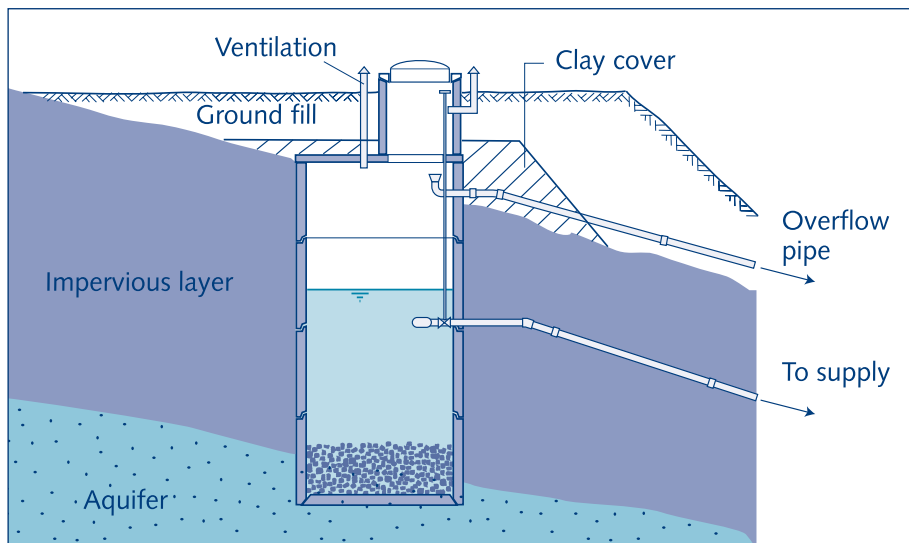

Fig. 8.16. Fissure spring of large capacity

Where the outflow of water occurs at only one point, the spring water can be tapped in a small intake construction. For a large lateral spring, a retaining wall should be constructed over its full width, with the borders extending into the over-lying impervious layers and the base of the wall reaching into the bedrock. In this way, leakage of water and any risks of erosion and collapse are avoided.

8.6 Protection of catchment and direct spring surroundings

Catchment protection

Protection of the catchment has two main objectives: (i) to improve the recharge of the aquifer, and (ii) to prevent contamination of the groundwater. Catchment protection therefore involves planning, implementation and motivation to refrain from or substantially reduce human and economic activities that could cause adverse effects on the quality and quantity of the water from the spring. Production of fodder grass and crops not requiring application of chemicals are permitted, but the feeding of animals on this fodder grass should be outside the catchment area. Protection rules and other decisions are preferably made by the local (user) communities after analysing the situation and the most suitable actions that can be taken locally.

Although trees/plants stabilise the soil and reduce erosion, they should be selected to avoid those that will compete for water (such as eucalyptus). Useful trees are, for example, pine or indigenous species (consult the Forestry Department and use local wisdom).

There are many problems associated with the protection of the catchment, including land ownership, change of habits and traditional beliefs. For individuals, reluctance to surrender their land for communal interest is a common problem. Some may consider the area to be very fertile and therefore not want to sacrifice it. Others link it to their ancestors' origins, and regard it as sacred. These problems bring conflicts in the community. Some local governments now have a legal status which allows them to regulate demarcation and intervention in an area chosen for catchment protection.

Protection of the spring surrounding

The immediate area around the spring (at least with a 50 m radius) must be fenced with barbed wire or an alternative barrier decided by the community. In this area definitely no human activities such as farming, grazing and hunting are allowed. Protection activities here include soil conservation, erosion control, drainage work and planting of trees, shrubs and grasses.

Bibliography

Bryan, K. (1919). 'Classification of springs'. In: *Journal of geology*, vol. 27, p. 522-561.

Cairncross, S. and Feachem, R. (1993). *Environmental health engineering in the tropics: an introductory text*. 2nd ed. Chichester, UK, John Wiley & Sons.

Helvetas Cameroon (1985). *Manual for rural water supply*. 5th ed. St. Gallen, Switzerland, SKAT and ATOL.

Johnson, C.R. (1976). *Village water systems*. Kathmandu, Nepal, UNICEF.

National Academy of Sciences (1974). *More water for arid lands*. Washington, DC, USA, National Academy Press. Reprint available at: <http://www.ciesin.org/docs/006-242/006-242.html>

Savary, I. (1973). 'Investigation of springs: the most effective method for estimating water resources in carbonate aquifers' In: *Resources Journal (Proceedings of the International Symposium on Development of Groundwater Resources)*, vol. 1, p. 53-62.

Zimmerman, T. (1996). *A manual on watershed resources management in the western highlands of Cameroon: basic information for technicians working on soil – forest and water conservation in water intake areas and watersheds of rural water supplies*. Bamenda, Cameroon, Helvetas Cameroon.

Meuli, C. and Wehrle, K. (2001). *Spring catchment*. (Manuals on drinking water and sanitation; no. 4). St. Gallen, Switzerland, SKAT.

Web sites

<http://www.skat.ch/>

Discussion groups

<http://www.lboro.ac.uk/departments/cv/wedc/garnet/>

