

SECOND EDITION

Residential Structural Design Guide

A State-of-the-Art Engineering
Resource for Light-Frame Homes,
Apartments, and Townhouses



Residential Structural Design Guide

***A State-of-the-Art Engineering Resource
for Light-Frame Homes,
Apartments, and Townhouses***

Second Edition

Prepared for

U.S. Department of Housing and Urban Development
Office of Policy Development and Research

Prepared by
Coulbourne Consulting

October 2017

Acknowledgments

This document was prepared by Coulbourn Consulting, a sole proprietor structural engineering consultant, and sponsored by the U.S. Department of Housing and Urban Development. The principal authors of the guide are William L. Coulbourn, P.E., William Bracken, P.E., Dr. John van de Lindt, and Dr. David Prevatt, P.E. Graphics were produced by Bracken Engineering, and document editing and formatting was performed by Casey Thayer of Outreach Process Partners, LLC. Special appreciation is extended to Jay Crandell, P.E., Eric Stafford, P.E. and Dr. Daniel Dolan for their review and guidance throughout the project. Appreciation is also extended to the following individuals, whose comments made this work more complete and accurate: James Baty (American Concrete Institute), Fred Bowen (National Council of Structural Engineers Associations), Charles Carter (American Institute of Steel Construction), Kelly Cobeen (Wiss, Janney, Elstner Associates, Inc.), Dennis Graber (National Concrete Masonry Association), Gary Ehrlich (National Association of Home Builders), John Ingargiola (Federal Emergency Management Agency), Vladimir Kochkin (National Association of Home Builders Research Center), Dan Lavrich (American Society of Civil Engineers, Structural Engineering Institute), Phil Line (American Wood Council), Hamid Naderi (International Code Council), Larry Novak (Portland Cement Association), Long Phan (National Institute of Standards and Technology), Tim Reinhold (Insurance Institute for Business & Home Safety), Robert Ross (Forest Products Laboratory), Tim Smail (Federal Alliance for Safe Homes), and B.J. Yey (APA—The Engineered Wood Association).

Disclaimer

Although the information in this document is believed to be accurate, neither the authors, the reviewers, the U.S. Department of Housing and Urban Development, Coulbourn Consulting, nor any of their employees or representatives makes any warranty, guarantee, or representation, expressed or implied, with respect to the accuracy, effectiveness, or usefulness of any information, method, or material in this document, nor assumes any liability for the use of any information, methods, or materials disclosed herein, or for damages arising from such use. This publication is intended for the use of professional personnel who are competent to evaluate the significance and limitations of the reported information and who will accept responsibility for the application of the material it contains. All responsibility as to the appropriate use of information in this document is the responsibility of the reader or user.

Preface

This document is a unique and comprehensive tool for design professionals, particularly structural engineers, seeking to provide value-added services to the producers and consumers of American housing. As such, the guide is organized around the following major objectives.

- To present a sound perspective on American housing relative to its history, construction characteristics, regulation, and performance experience.
- To provide the latest technical knowledge and engineering approaches for the design of homes to complement current code-prescribed design methods.
- To assemble relevant design data and methods in a single, comprehensive format that is instructional and simple to apply for the complete design of a home.
- To reveal areas in which gaps in existing research, design specifications, and analytic tools necessitate alternative methods of design and sound engineering judgment to produce efficient designs.

This guide consists of seven chapters. The layout and application of the various chapters are illustrated in the figure on page vi. Chapter 1 describes the basic substance of American housing, including conventional construction practices, alternative materials, building codes and standards, the role of design professionals, and actual experience with respect to performance problems and successes. Chapter 2 introduces basic engineering concepts regarding safety, load path, and the structural system response of residential buildings, subassemblies, and components to various types of loads. Chapter 3 addresses design loads applicable to residential construction. Chapters 4 and 5 provide step-by-step design procedures for the various components and assemblies comprising the structure of a home—from the foundation to the roof. Chapter 6 is devoted to the design of light-frame homes to resist lateral loads from wind and earthquakes. Chapter 7 addresses the design of various types of connections in a wood-framed home that are important to the overall function of the numerous component parts. As appropriate, the guide offers additional resources and references for the topics addressed.

Given that most homes in the United States are built with wood structural materials, the guide focuses on appropriate methods of design associated with wood for the above-grade portion of the structure. Concrete and masonry are generally assumed to be used for the below-grade portion of the structure, although preservative-treated wood may also be used. Other materials and systems using various innovative approaches are considered in abbreviated form, as appropriate. In some cases, innovative materials or systems can be used to address specific issues in the design and performance of homes. For example, cold-formed steel framing is becoming popular in many states because of

either the high cost of wood or concerns with decay and termite damage. Likewise, partially reinforced masonry construction is used extensively in Florida and the southeast because of its demonstrated ability to perform in high winds.

For typical wood-framed homes, the primary markets for engineering services lie in special load conditions, such as girder design for a custom house; corrective measures, such as repair of a damaged roof truss or floor joist; high-hazard conditions created by earthquakes on the West Coast, the intermountain west, the central United States, and South Carolina and by hurricanes along the Gulf and Atlantic coasts; and the increasing requirements for braced wall design in other locations. The design recommendations in this guide are based on the best information available to the authors for the safe and efficient design of homes. Much of the technical information and guidance is supplemental to building codes, standards, and design specifications that define current engineering practice. In fact, current building codes may not explicitly recognize some of the technical information or design methods described or recommended in the guide because the codes are minimums designed to protect lives, not to reduce property damage. A competent professional designer, therefore, should first compare and understand any differences between the content of this guide and local building code requirements. Any actual use of this guide by a competent professional may require appropriate substantiation as an “alternative method of analysis.” The guide and references provided herein should help furnish the necessary documentation.

Use of alternative means and methods of design should not be taken lightly or without first carefully considering the wide range of implications related to the applicable building code’s minimum requirements for structural design, the local process of accepting alternative designs, the acceptability of the proposed alternative design method or data, and exposure to liability when attempting something new or innovative, even when the process is carried out correctly. The intent of this guide is not to steer a designer unwittingly into noncompliance with current regulatory requirements for the practice of design as governed by local building codes. Instead, the intent is to provide technical insights into and approaches to home design that have not been compiled elsewhere but that deserve recognition and consideration. The guide is also intended to be instructional in a manner relevant to the current state of the art of home design.

Finally, it is hoped that this guide will foster a better understanding among engineers, architects, building code officials, and home builders by clarifying the perception of homes as structural systems. As such, the guide should help structural designers perform their services more effectively and assist in integrating their skills with other professionals who contribute to the production of safe and affordable homes in the United States.

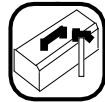

CHAPTER 1
BASICS OF RESIDENTIAL CONSTRUCTION

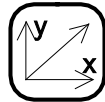

CHAPTER 2
STRUCTURAL DESIGN CONCEPTS

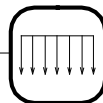

CHAPTER 3
DESIGN LOADS FOR
RESIDENTIAL BUILDINGS



CHAPTER 6
LATERAL RESISTANCE TO
WIND AND EARTHQUAKES

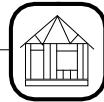

CHAPTER 5
DESIGN OF WOOD
FRAMING

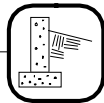

CHAPTER 4
DESIGN OF
FOUNDATIONS

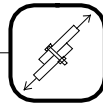

CHAPTER 7
CONNECTIONS

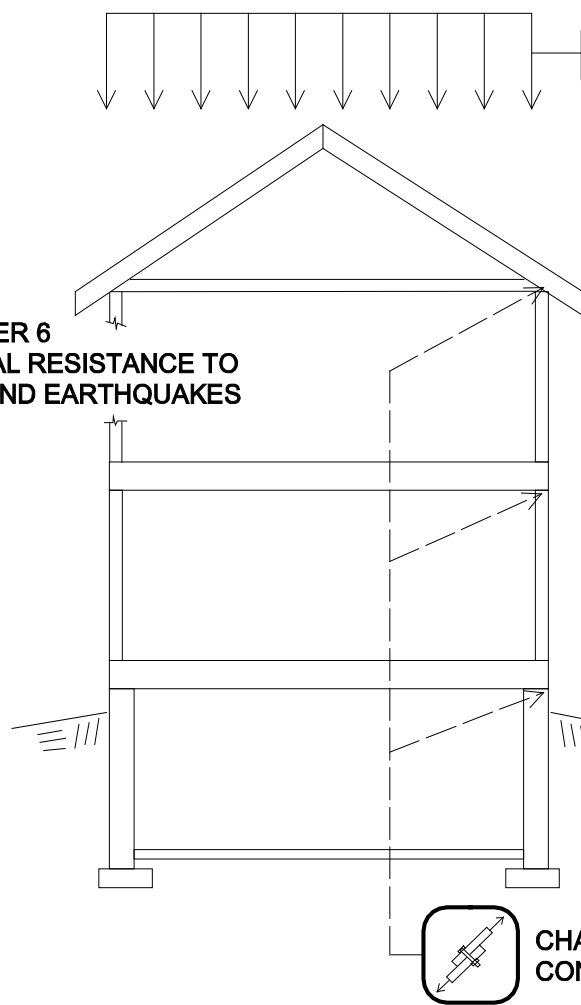

CHAPTER LAYOUT AND APPLICATION GUIDE

Contents

Page



Chapter 1—Basics of Residential Construction

1.1	Conventional Residential Construction	1-1
1.2	Factory-Built Housing	1-7
1.3	Alternative Materials and Methods.....	1-7
1.4	Building Codes and Standards.....	1-13
1.5	Role of the Design Professional.....	1-14
1.6	Housing Structural Performance.....	1-15
1.7	Summary	1-17
1.8	References.....	1-19



Chapter 2—Structural Design Concepts

2.1	General.....	2-1
2.2	What Is Structural Design?.....	2-1
2.3	Load Types and Whole Building Response.....	2-3
2.4	Load Path	2-7
2.5	Structural Reliability.....	2-15
2.6	References.....	2-24



Chapter 3—Design Loads for Residential Buildings

3.1	General.....	3-1
3.2	Load Combinations.....	3-2
3.3	Dead Loads	3-4
3.4	Live Loads	3-6
3.5	Soil Lateral Loads.....	3-8
3.6	Wind Loads.....	3-12
3.7	Snow Loads.....	3-22
3.8	Earthquake Loads.....	3-25
3.9	Flood Loads	3-32
3.10	Tornadoes.....	3-33
3.11	Other Load Conditions.....	3-34
3.12	Design Examples	3-36
3.13	References.....	3-42



Chapter 4—Design of Foundations

4.1	General.....	4-1
4.2	Material Properties.....	4-5
4.3	Soil-Bearing Capacity and Footing Size.....	4-9
4.4	Footings.....	4-12
4.5	Foundation Walls.....	4-23
4.6	Slabs on Grade.....	4-54
4.7	Pile Foundations.....	4-56
4.8	Frost Protection.....	4-58
4.9	Design Examples.....	4-64
4.10	References.....	4-88



Chapter 5—Design of Wood Framing

5.1	General.....	5-1
5.2	Material Properties.....	5-3
5.3	Structural Evaluation.....	5-14
5.4	Floor Framing.....	5-23
5.5	Wall Framing.....	5-33
5.6	Roofs.....	5-40
5.7	Design Examples.....	5-50
5.8	References.....	5-73



Chapter 6—Lateral Resistance to Wind and Earthquakes

6.1	General.....	6-1
6.2	Overview of Whole-Building Tests.....	6-3
6.3	LFRS Design Steps and Terminology.....	6-7
6.4	The Current LFRS Design Practice.....	6-13
6.5	Design Guidelines.....	6-21
6.6	Design Examples.....	6-42
6.7	References.....	6-68



Chapter 7—Connections

7.1	General.....	7-1
7.2	Types of Mechanical Fasteners.....	7-2
7.3	Wood Connection Design.....	7-11
7.4	Design of Concrete and Masonry Connections.....	7-23
7.5	Design Examples.....	7-30
7.6	References.....	7-45

Appendix A—Shear and Moment Diagrams and Beam Equations

Appendix B—Unit Conversions

List of Figures

Page



Chapter 1—Basics of Residential Construction

Figure 1.1a: Post-and-Beam Construction (Historical).....	1-2
Figure 1.1b: Balloon-Frame Construction (Historical)	1-3
Figure 1.1c: Platform-Frame Construction (Modern).....	1-4
Figure 1.2: Modern Platform-Framed House Under Construction	1-5
Figure 1.3: House Construction Using Engineered Wood Components.....	1-9
Figure 1.4: House Construction Using Cold-Formed Steel Framing.....	1-10
Figure 1.5: House Construction Using Insulating Concrete Forms	1-11
Figure 1.6: House Construction Using Concrete Masonry	1-12



Chapter 2—Structural Design Concepts

Figure 2.1: Vertical Load Path for Gravity Loads.....	2-8
Figure 2.2: Vertical Load Path for Wind Uplift	2-9
Figure 2.3: Lateral Load Path.....	2-13
Figure 2.4: Building Deformation Under Lateral Load.....	2-14
Figure 2.5: Basic Concept of Safety in LRFD and ASD Considering the Variability of Loads and Resistance	2-22



Chapter 3—Design Loads for Residential Buildings

Figure 3.1: Triangular Pressure Distribution on a Basement Foundation Wall	3-9
Figure 3.2a: Basic Design Wind Speed Map From ASCE 7-10	3-14
Figure 3.2b: Basic Design Wind Speed Map From ASCE 7-10	3-15
Figure 3.3a: Ground Snow Loads (ASCE 7-10)	3-23
Figure 3.3b: Ground Snow Loads (ASCE 7-10)	3-24
Figure 3.4a: Mapped Risk-Targeted Maximum Considered Earthquake (MCE _R) Spectral Response Acceleration.....	3-26
Figure 3.4b: Mapped Risk-Targeted Maximum Considered Earthquake (MCE _R) Spectral Response Acceleration.....	3-27



Chapter 4—Design of Foundations

Figure 4.1: Types of Foundations.....	4-4
Figure 4.2: Critical Failure Planes in Continuous or Square Concrete Spread Footings ..	4-16
Figure 4.3: Shear Calculations for Plain Concrete Walls: Variables Defined	4-26
Figure 4.4: Shear Calculations in Reinforced Concrete Walls: Variables Defined	4-29
Figure 4.5: Typical Interaction Diagrams for Plain and Reinforced Concrete Walls	4-33
Figure 4.6: Design Variables Defined for Lintel Bending and Shear	4-36

Figure 4.7: Shear Calculations in Reinforced Concrete Masonry Walls: Variables Defined.....	4-46
Figure 4.8: Concrete Masonry Wall Lintel Types.....	4-49
Figure 4.9: Preservative-Treated Wood Foundation Walls.....	4-51
Figure 4.10: Insulating Concrete Form Foundation Walls.....	4-54
Figure 4.11: Basic Coastal Foundation Construction.....	4-57
Figure 4.12: Air-Freezing Index Map (100-Year Return Period)	4-61
Figure 4.13: Frost-Protected Shallow Foundation Applications	4-63



Chapter 5—Design of Wood Framing

Figure 5.1: Components and Assemblies of a Conventional Wood-Framed Home	5-2
Figure 5.2: Structural Elements of the Floor System	5-25
Figure 5.3: Conventional and Alternative Floor Framing Members.....	5-27
Figure 5.4: Examples of Beams and Girders.....	5-30
Figure 5.5: Structural Elements of the Wall System	5-34
Figure 5.6: Wood Column Types	5-39
Figure 5.7: Structural Elements of a Conventional Roof System	5-41
Figure 5.8: Design Methods and Assumptions for a Sloped Roof Rafter	5-44
Figure 5.9: Typical Roof Overhang Constructions	5-48
Figure 5.10: Gable-End Wall Bracing.....	5-50



Chapter 6—Lateral Resistance to Wind and Earthquakes

Figure 6.1: Twin Garages on Shake Tables, SUNY Buffalo	6-5
Figure 6.2: Six-Story Building on Shake Table, Miki, Japan	6-6
Figure 6.3: Chords in Shear Walls and Horizontal Diaphragms Using the “Deep Beam” Analogy	6-9
Figure 6.4: Shear Wall Collector and Composite Failure Plane	6-10
Figure 6.5: Two Types of Hold-Down Restraint and Basic Analytic Concepts	6-12
Figure 6.6: Lateral Force Distribution by a “Flexible” Diaphragm (Tributary Area Approach)	6-14
Figure 6.7: Basic Perforated Shear Wall	6-19
Figure 6.8: Evaluation of Overturning Forces on a Restrained Shear Wall Segment.....	6-33
Figure 6.9: Moment Frame.....	6-38



Chapter 7—Connections

Figure 7.1: Elements of a Nail and Nail Types	7-3
Figure 7.2: Bolt and Connection Types.....	7-7
Figure 7.3: Specialty Connector Hardware	7-10
Figure 7.4: Types of Connections and Loading Conditions.....	7-13
Figure 7.5: Concrete or Masonry Wall-to-Footing Connections.....	7-25
Figure 7.6: Key in Concrete Footings	7-26
Figure 7.7: Dowel Placement in Concrete Footings.....	7-27

Appendix A—Shear and Moment Diagrams and Beam Equations

Figure A.1: Simple Beam (Foundation Wall)—Partial Triangular Load.....	A-1
Figure A.2: Simple Beam (Wall or Column)—Eccentric Point Load	A-2
Figure A.3: Simple Beam—Uniformly Distributed Load.....	A-2
Figure A.4: Simple Beam—Load Increasing Uniformly to One End.....	A-3
Figure A.5: Simple Beam—Concentrated Load at Any Point	A-3
Figure A.6: Simple Beam—Two Unequal Concentrated Loads Unsymmetrically Placed	A-4
Figure A.7: Cantilever Beam—Uniformly Distributed Load	A-4
Figure A.8: Cantilever Beam—Concentrated Load at Any Point.....	A-5
Figure A.9: Beam Fixed at One End, Supported at Other—Uniformly Distributed Load..	A-5
Figure A.10: Beam Fixed at One End, Supported at Other—Load at Any Point	A-6
Figure A.11: Beam Fixed at Both Ends—Uniformly Distributed Load	A-6
Figure A.12: Beam Fixed at Both Ends—Concentrated Load at Any Point.....	A-7
Figure A.13: Beam Overhanging One Support—Uniformly Distributed Load.....	A-7
Figure A.14: Beam Overhanging One Support—Concentrated Load at End of Overhang ..	A-8
Figure A.15: Continuous Beam—Two Equal Spans and Uniformly Distributed Load.....	A-8
Figure A.16: Continuous Beam—Two Equal Spans With Uniform Load on One Span.....	A-9
Figure A.17: Continuous Beam—Two Unequal Spans and Uniformly Distributed Load ...	A-9

List of Tables

Page



Chapter 2—Structural Design Concepts

Table 2.1:	Building Loads Categorized by Orientation	2-3
------------	---	-----



Chapter 3—Design Loads for Residential Buildings

Table 3.1:	Typical Load Combinations Used for the Design of Components and Systems	3-4
Table 3.2:	Dead Loads for Common Residential Construction	3-5
Table 3.3:	Densities for Common Residential Construction Materials	3-6
Table 3.4:	Live Loads for Residential Construction	3-7
Table 3.5:	Live Load Element Factor, K_{LL}	3-8
Table 3.6:	Values of K_a , Soil Unit Weight, and Equivalent Fluid Density by Soil Type	3-10
Table 3.7:	Lateral Soil Load	3-11
Table 3.8:	Basic Wind Velocity Pressures (psf) for Suburban Terrain (MWFRS)	3-16
Table 3.9:	Lateral Pressure Coefficients for Application to Vertical Projected Areas	3-17
Table 3.10:	Wind Pressure Coefficients for Systems and Components	3-19
Table 3.11:	Missile Types for Wind-Borne Debris Impact Tests	3-21
Table 3.12:	Site Soil Amplification Factor Relative to Acceleration (short period, Site Class D)	3-29
Table 3.13:	Seismic Design Factors for Residential Construction	3-30



Chapter 4—Design of Foundations

Table 4.1:	Rebar Size, Diameter, and Cross-Sectional Areas	4-7
Table 4.2:	Presumptive Soil-Bearing Values by Soil Description	4-10
Table 4.3:	Presumptive Soil-Bearing Values (psf) Based on Standard Penetrometer Blow Count	4-11
Table 4.4:	Minimum Compressive Strength f'_c at 28 days and Maximum Slump of Concrete	4-24
Table 4.5:	Simplified Moment Magnification Factors, δ_{ns}	4-32
Table 4.6:	Nominal Wall Thickness for 8-Foot High Masonry Foundation Walls	4-39
Table 4.7:	Allowable Flexural Tension Stresses (F_a) for Allowable Stress Design of Unreinforced Masonry	4-40
Table 4.8:	Preservative-Treated Wood Foundation Framing	4-52
Table 4.9:	Minimum Frost Depths for Residential Footings	4-59



Chapter 5—Design of Wood Framing

Table 5.1:	Adjustment Factor Applicability to Design Values for Wood	5-10
Table 5.2:	Recommended Load Duration Factors for ASD	5-12
Table 5.3:	Recommended Repetitive Member Factors for Dimension Lumber Used in Framing Systems	5-13
Table 5.4:	Recommended Allowable Deflection Limits	5-20
Table 5.5:	Fastening Floor Sheathing to Structural Members	5-32



Chapter 6—Lateral Resistance to Wind and Earthquakes

Table 6.1:	Nominal Shear Resistance (plf) for Wood Structural Panel Shear Walls with Framing of Douglas-Fir, Larch, or Southern Pine	6-24
Table 6.2:	Nominal Unit Shear Resistance (plf) for Walls with Cold-Formed Steel Framing and Wood Structural Panels	6-25
Table 6.3:	Nominal Unit Shear Values (plf) for 1/2-Inch Thick Gypsum Wall-board Sheathing	6-26
Table 6.4:	Horizontal Diaphragm Maximum Nominal Shear Values (plf) for Unblocked Roof and Floor Construction Using Douglas-Fir Framing	6-39



Chapter 7—Connections

Table 7.1:	Nail Types, Sizes, and Dimensions	7-5
Table 7.2:	Common Framing Lumber Species and Specific Gravity Values	7-12

CHAPTER 1

Basics of Residential Construction

1.1 Conventional Residential Construction

The conventional American house has been shaped over time by a variety of factors. Foremost, the abundance of wood as a readily available resource has dictated traditional American housing construction, beginning as log cabins, then as post-and-beam structures, and finally as light-frame buildings. The basic residential construction technique, which has remained much the same since the introduction of light wood-framed construction in the mid-1800s, is generally referred to as conventional construction. See figures 1.1a through 1.1c for illustrations of various historical and modern construction methods using wood. Today, a wood framed residential building can be typically constructed in one of two ways: (1) conventionally framed, constructed from wall panels built in a factory, and assembled on the jobsite, or (2) built in a factory and brought to a jobsite and placed on a site-built foundation.

In *post-and-beam framing*, structural columns support horizontal members. Post-and-beam framing is typified by the use of large timber members. Traditional *balloon framing* consists of closely spaced light vertical structural members that extend from the foundation sill to the roof plates. *Platform framing* is the modern adaptation of balloon framing, whereby vertical members extend from the floor to the ceiling of each story. Balloon and platform framings are not simple adaptations of post-and-beam framing but are actually unique forms of

wood construction. Platform framing is used today in most wood-framed buildings; however, variations of balloon framing may be used in certain parts of otherwise platform-framed buildings, such as great rooms, stairwells, and gable-end walls, where continuous wall framing provides greater structural integrity. Figure 1.2 depicts a modern home under construction.

FIGURE 1.1a *Post-and-Beam Construction (Historical)*

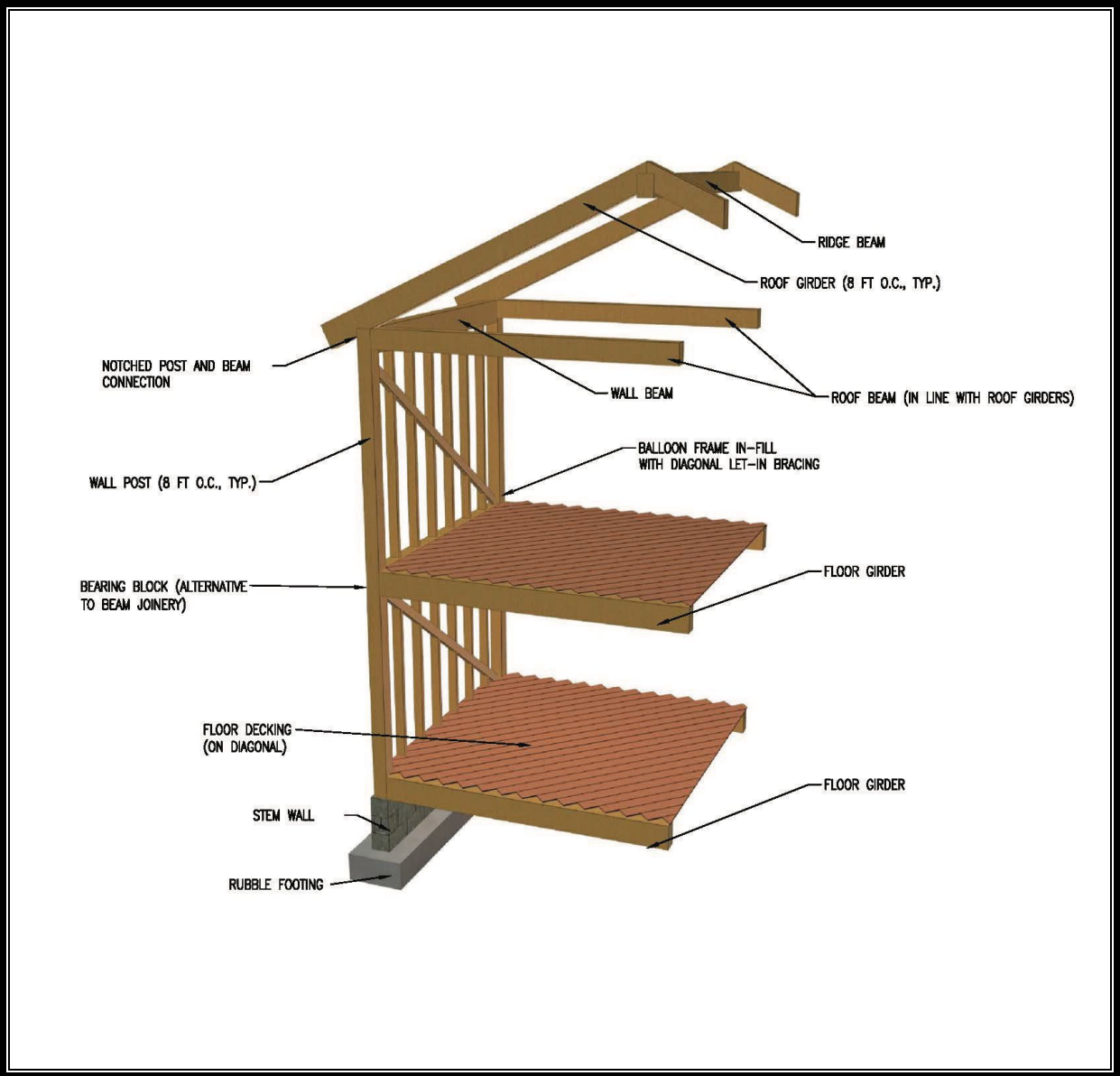

FIGURE 1.1b *Balloon-Frame Construction (Historical)*

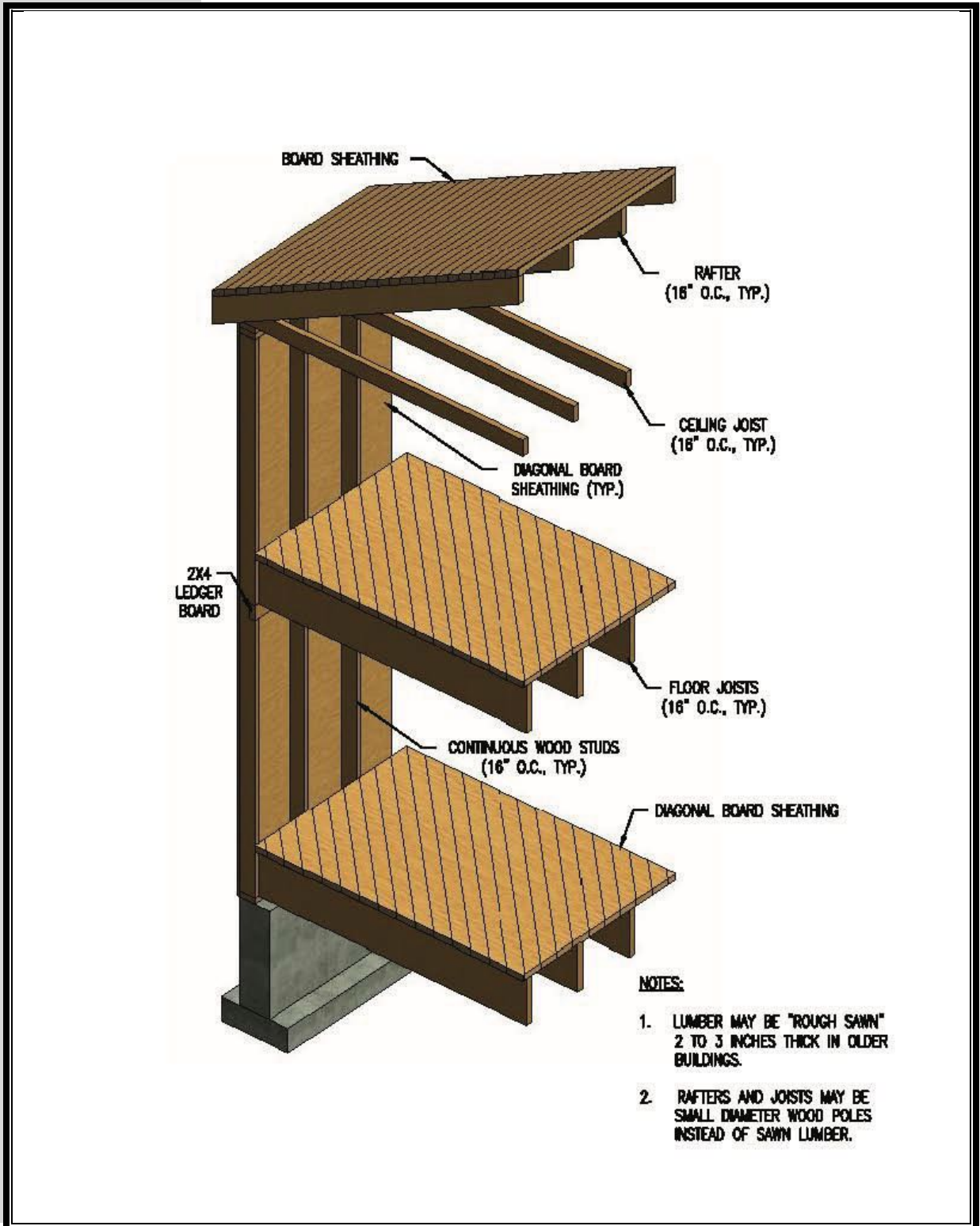

FIGURE 1.1c

Platform-Frame Construction (Modern)

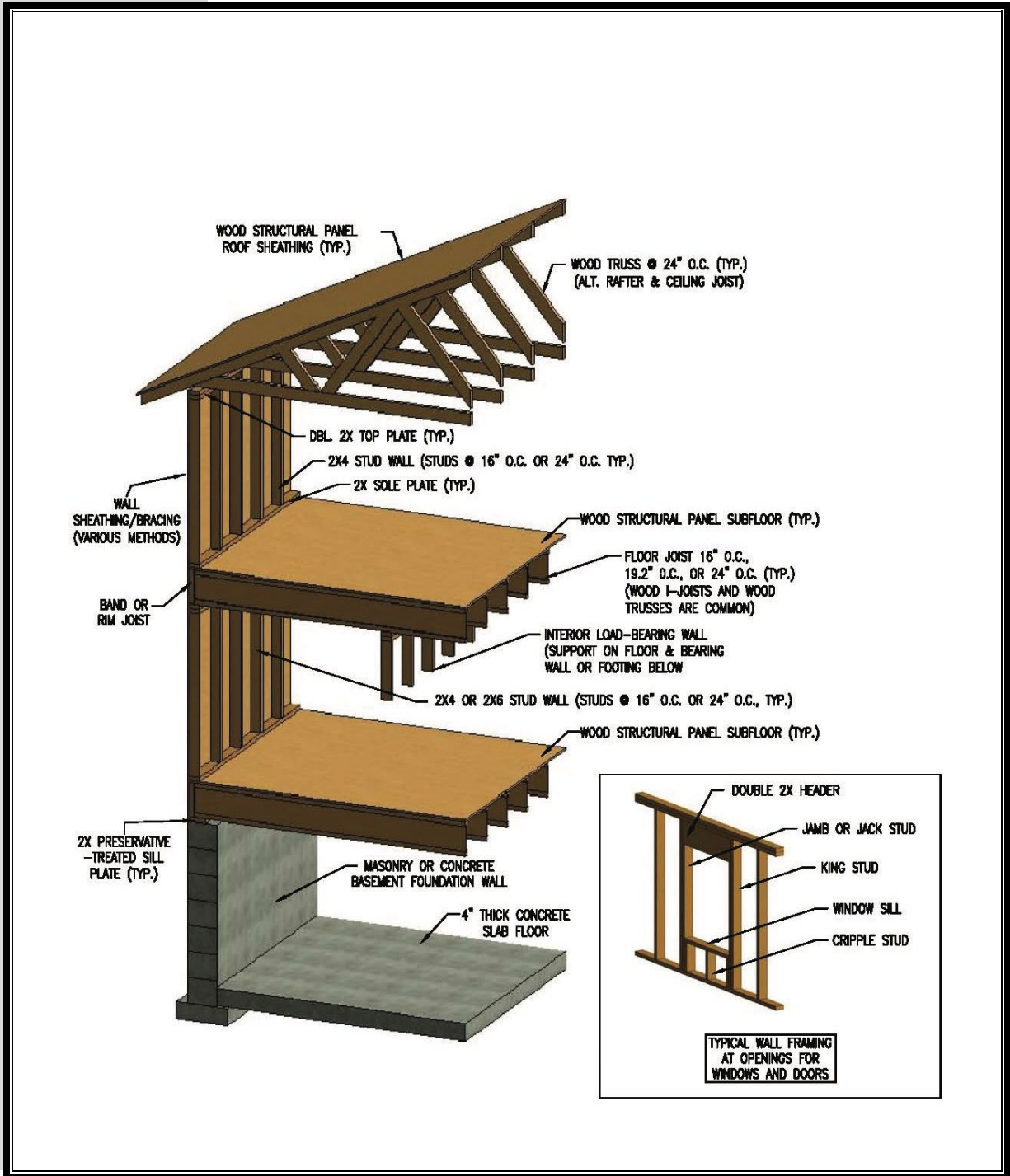

FIGURE 1.2

Modern Platform-Framed House Under Construction



Conventional or prescriptive construction practices are based as much on experience as on technical analysis and theory (HEW, 1931). The minimum building code requirements provided by the International Residential Code (IRC) have codified conventional construction practices but do have some basis in basic engineering principles. The prescriptive construction requirements provided in the IRC are intended to be easy for a builder to follow and for a code official to inspect without the services of a design professional. It is also common for design professionals, including architects and engineers, to apply conventional practices in typical design conditions but to undertake special designs for certain parts of a home that are beyond the scope of the IRC or a prescriptive residential design guide. It is very important for design professionals to understand the limitations of the prescriptive code when relying on it. The housing market historically has operated with minimal involvement of design professionals. As building codes advance, environmental loads become better understood, and performance demands on residential construction continue to increase, however, so too does the role of the design professional. Section 1.5 explores the current role of design professionals in residential construction.

Although dimensional lumber has remained the predominant material used in the last century of American housing construction, the size of the material has been reduced from the rough-sawn, 2-inch-thick members used in the late 1800s to today's nominal dressed sizes, with actual thicknesses of less than 1.5 inches for standard framing lumber. The result has been a significant improvement in economy and resource use accompanied by significant structural tradeoffs.

The mid-to-late 1900s also saw several significant innovations in pre-engineered wood products and wood-framed construction techniques. One example is the development of the metal plate-connected wood truss in the 1950s. Metal plate-connected wood trusses, most often referred to as pre-engineered wood trusses, are now used in many new homes because the pre-engineered method is generally more efficient than older framing methods that rely on roof rafters. In addition to being used in roof framing, pre-engineered wood trusses and beams are also used in floor framing. As floor framing, these trusses are able to increase floor rigidity and the spans of flooring systems, eliminating some interior load-bearing walls. Other examples of innovative products and techniques are plywood structural sheathing panels that entered the market in the 1950s and oriented strand board (OSB) that entered the market in the 1980s. Both products quickly replaced board sheathing on walls, floors, and roofs.

It is important to recognize that, while the previously mentioned changes in materials and methods were occurring, significant changes in house designs also occurred, in the way of larger homes with more complicated architectural features, long-span floors and roofs, and large open interior spaces. The collective effect of these changes on the structural qualities of most homes is certainly notable.

The following references are recommended for a more in depth understanding of conventional housing design, detailing, and construction. Section 1.8—References—provides detailed citations.

- *2012 International Residential Code* (ICC, 2012a).
- *2012 International Building Code* (ICC, 2012b).
- *Wood Frame Construction Manual* (AWC, 2012b).
- *Modern Carpentry—Building Construction Details in Easy-to-Understand Form*, 10th ed. (Wagner, 2003).

The following structural design references are also recommended for use with chapters 3 through 7 of this guide.

- NDS—*National Design Specification for Wood Construction and Supplement* (AWC, 2012a).
- ACI-318—*Building Code Requirements for Structural Concrete* (ACI, 2011a).
- ACI-530—*Building Code Requirements for Masonry Structures* (ACI, 2011).
- ASCE 7-10—*Minimum Design Loads for Buildings and Other Structures* (ASCE, 2010).

1.2 Factory-Built Housing

Most homes in the United States are still site built; that is, they follow a *stick-framing* approach. With this method, wood members are assembled on site from the foundation up. The primary advantage of onsite building is flexibility in meeting variations in housing styles, design details, and changes specified by the owner or builder. An increasing number of today's site-built homes, however, use components that are fabricated in an offsite plant. Prime examples include wall panels (both structural insulated panels [SIPs] and those built with dimensional lumber) and pre-engineered wood trusses. The blend of stick-framing and factory-built components is referred to as *component building*.

Modular housing is a step beyond component building. *Modular housing* is constructed in essentially the same manner as site-built housing except that houses are factory-built in finished modules (typically two or more modules) and shipped to the jobsite for placement on site-built foundations. Modular housing is built to comply with the same building codes that govern site-built housing.

Manufactured housing (formerly known as mobile homes) is also constructed using wood-framed methods and components; however, these methods and components are required to comply only with the federal preemptive standards specified in the Manufactured Housing Construction Safety Standards (U.S. Department of Housing and Urban Development code). This popular form of industrialized housing is completely factory assembled and then delivered to a site by using an integral chassis for over-the-road travel and foundation support.

1.3 Alternative Materials and Methods

Several innovations in structural materials have been introduced more recently to residential construction. Alternatives to conventional wood-framed construction are in fact gaining recognition in modern building codes. It is important for designers to become familiar with these alternatives because their effective integration into conventional home building may require the services of a design professional. In addition, a standard practice in one region of the country may be viewed as an alternative in another, which provides opportunities for innovation across regional norms.

Many options in the realm of materials are already available. The following pages describe several significant examples. In addition, the following contacts are useful for obtaining design and construction information on the alternative materials and methods for house construction.

General contacts

HUD User (<http://huduser.gov>).

ToolBase (<http://toolbase.org>).

Engineered wood products

American Wood Council (<http://awc.org>).

APA–The Engineered Wood Association (<http://apawood.org>).
Structural Building Components Association (<http://sbcindustry.com>).

Cold-formed steel

Steel Framing Alliance (<http://steelframingalliance.com>).
American Iron and Steel Institute (<http://steel.org>).
Cold-Formed Steel Engineers Institute (<http://cfsei.org>).

Insulating concrete forms

EPS Industry Alliance (<http://forms.org>).

Structural Insulated Panels

Structural Insulated Panel Association (<http://www.sips.org>).

Masonry

National Concrete Masonry Association (<http://ncma.org>).

Engineered wood products and components (see figure 1.3) have gained considerable popularity in the past 30 years. Engineered wood products and components include wood-based materials and assemblies of wood products with structural properties similar to or better than the sum of their component parts. Examples include metal plate-connected wood trusses, wood I-joists, laminated veneer lumber (LVL), plywood, oriented strand board (OSB), glue-laminated lumber, and parallel strand lumber (PSL). OSB structural panels are rapidly displacing plywood as a favored product for wall, floor, and roof sheathing. Wood I-joists are now used in 54 percent of the total framed floor area in all new homes each year (APA, 2013). Cross-laminated timber, (CLT) is now being manufactured in Canada, consists of laminated layers of solid sawn or structural composite lumber that are bonded with structural adhesives to form a rectangular-shaped timber. This product is expected to be more widely available in the United States in coming years.

The increased use of engineered wood products is the result of many years of research and product development and, more importantly, reflects the economics of the building materials market. Engineered wood products often offer improved dimensional stability, increased structural capability, ease of construction, and more efficient use of the nation’s lumber resources, and they do not require a significant change in construction technique.

The designer should, however, carefully consider the unique detailing and connection requirements associated with engineered wood products and ensure that the requirements are clearly understood in the design office and at the jobsite. Design guidance, such as span tables and construction details, is usually available from the manufacturers of these predominantly proprietary products. A note of caution: for these proprietary products to be supported by the manufacturer, they must be installed exactly in accordance with the manufacturer’s instructions.

FIGURE 1.3

House Construction Using Engineered Wood Components



Cold-formed steel framing (previously known as light-gauge steel framing) was originally produced by a fragmented industry with nonstandardized products serving primarily the commercial design and construction market. In cooperation with the industry, HUD sponsored research necessary to develop standard minimum dimensions and structural properties for basic cold-formed steel framing materials, which resulted in the development of IRC design provisions. Cold-formed steel framing is currently used in exterior and interior walls of new housing starts. The benefits of cold-formed steel include low cost, durability, light weight, and strength (HUD, 1994). Figure 1.4 illustrates the use of cold-formed steel framing in a home. Construction methods can be found in the *International Residential Code* (ICC, 2012a).

FIGURE 1.4

House Construction Using Cold-Formed Steel Framing



Insulating concrete form (ICF) construction, as illustrated in figure 1.5, combines the forming and insulating functions of concrete construction in a single step. In a cooperative effort between the housing industry and HUD, the product class was included in the I-Codes after the establishment of minimum dimensions and standards for ICF construction. The benefits of ICF construction include durability, strength, noise control, and energy efficiency (HUD, 1998a; HUD, 1998b). The method, detailed in *Prescriptive Method for Insulating Concrete Forms in Residential Construction*, has been adopted by the IRC and is also discussed in the *Prescriptive Design of Exterior Concrete Walls* (PCA, 2012).

FIGURE 1.5

House Construction Using Insulating Concrete Forms



Structural insulated panels (SIPs), are composite panels of polystyrene or polyurethane foam sandwiched on both sides with OSB sheets. The panel size is typically the same as the manufactured size of the OSB sheets, but SIPs can also be larger. Individual SIPs are connected together by a vertical spline (splice) consisting of a 3-inch-wide OSB strip that bridges an expansion gap between the SIPs and is nailed to the OSB sheets on each side. A sufficient amount of foam is removed to allow the top and bottom plates to fit snugly inside the OSB. For additional stiffness, a further section of foam can be removed to accommodate abutting 2x studs or a foam block at the spline. This construction method eliminates the need for other insulation on the walls and roofs.

Concrete masonry construction, illustrated in figure 1.6, has remained essentially unchanged in its basic construction method. Recently introduced products offer innovations that provide structural and architectural benefits, however. Masonry construction is well recognized for its fire-safety qualities, durability, noise control, termite resistance, and strength. The installed cost of masonry construction, like most alternatives to conventional wood-framed construction, may be a local issue that needs to be balanced against other factors. For example, in hurricane-prone regions along the Gulf Coast and southern Atlantic states, standard concrete masonry construction dominates the market

because its performance in major hurricanes has been favorable when nominally reinforced using conventional practices.

FIGURE 1.6 *House Construction Using Concrete Masonry*



Reinforced concrete construction is a frequently used material and method in nonresidential construction that is gaining popularity in home construction in some parts of the country. This gain is because of its performance in extremely hot climates, in those locations with termite or woodboring insect issues, in those locations subject to either hurricane- or tornado-force winds, and for those building owners who want an exterior less prone to deterioration and severe weathering. Construction techniques in forming and pouring concrete for homes are the same as used for nonresidential construction.

Alternative materials and methods provisions exist within the IRC and the International Building Code (IBC). These building code provisions provide the flexibility for a design professional or builder to use new materials in construction that may not be discussed or even contemplated in building codes. The IRC and IBC provide this flexibility within chapter 1, which describes a process whereby the designer or builder and the code official can review and approve such approaches.

1.4 Building Codes and Standards

Most of the U.S. population lives in areas that are covered by legally enforceable building codes that govern the design and construction of buildings, including residential dwellings. Although building codes are legally a governmental police power, most states allow local political jurisdictions to adopt or modify building codes to suit their special needs or, in a few cases, to write their own code. Almost all jurisdictions adopt a family of model codes by legislative action instead of attempting to write their own code.

The dominant family of model building codes in the United States is that developed by the International Code Council (ICC). The ICC was founded in 1994 by the three regional code organizations—Building Officials and Code Administrators International, Inc.; International Conference of Building Officials; and Southern Building Code Congress International, Inc. This initiative was the result of the conclusion by the founders that the nation needed a single set of model building codes. The ICC has developed codes for all types of buildings and occupancies—from a backyard storage shed to a highrise office building and sports complex. In addition, some jurisdictions have also adopted building codes developed by the National Fire Protection Association (NFPA). The two major building code organizations are—

- International Code Council
500 New Jersey Avenue, NW
Washington, DC 20001
<http://iccsafe.org>
- National Fire Protection Association
1 Batterymarch Park
Quincy, MA 02169
<http://nfpa.org>

In the past, although the dominant codes included some “deemed-to-comply” prescriptive requirements for conventional house construction, they focused primarily on performance (that is, engineering) requirements. By focusing more on performance requirements, these codes were better able to address more complex buildings across the whole range of occupancy and construction types. Therefore, in an effort to provide a comprehensive, easier to use code for residential construction, the IRC was developed. Presented in logical construction sequence, the IRC is devoted entirely to simple prescriptive requirements for one- and two-family dwellings, duplexes, and townhouses. Many state and local jurisdictions have adopted both the IRC and the IBC. Thus, designers and builders enjoy a choice as to which set of requirements best suits their purpose.

Model building codes do not provide detailed specifications for all building materials and products but rather refer to established industry standards,

such as those promulgated by ASTM International, formerly known as the American Society for Testing and Materials (ASTM). Several ASTM standards are devoted to the measurement, classification, and grading of wood properties for structural applications and of virtually all other building materials, including steel, concrete, and masonry. Design standards and guidelines for wood, steel, concrete, and other materials or applications are also maintained as reference standards in building codes. More than 600 materials and testing standards from a variety of organizations currently are referenced in the building codes used in the United States.

For products and processes not explicitly recognized in the codes or standards, the ICC Evaluation Service, Inc. (ICC-ES) provides evaluations of products relative to the model code requirements. The ICC-ES report recognizes a specific building product's ability to meet the performance and prescriptive provisions in the code. It is an independent finding of the product's capability. The report provides engineers the assurance of validity and technical accuracy in determining a product's correct application. Reports are valid for a specific period of time. A report can undergo revisions at any time. Other organizations—such as Intertek, the International Association of Plumbing and Mechanical Officials, and Miami-Dade County, Florida—provide testing of building products for performance certifications and building code compliance.

Seasoned designers spend countless hours in careful study and application of building codes and selected standards that relate to their area of practice. These designers develop a sound understanding of the technical rationale and intent behind various provisions in applicable building codes and design standards. This experience and knowledge, however, can become even richer when coupled with practical experiences from the field. One of the most valuable sources of practical experience is the study of the successes and failures of past designs and construction practices, as presented in section 1.6.

1.5 Role of the Design Professional

Because the primary user of this guide is assumed to be a design professional, it is important to understand the role that design professionals can play in the residential construction process, particularly regarding recent trends. Design professionals offer a wide range of services to builders or developers in the areas of land development, environmental impact assessments, geotechnical and foundation engineering, architectural design, structural engineering, and construction monitoring. This guide, however, focuses on two approaches to design, as follows.

- **Conventional design.** Sometimes referred to as “prescriptive” construction, conventional design relies on standard practice and empirical methods as governed by prescriptive building code requirements (see section 1.4). This prescriptive approach, however, does not preclude and may even require some parts of the structure to be specially designed by an engineer or architect.

- **Engineered design.** Engineered design generally involves the application of engineering practice as represented within the building codes and design standards.

Some of the conditions that typically cause concern in the planning and preconstruction phases of home building and thus sometimes create the need for professional design services are—

- *Structural configurations*, such as unusually long floor spans, unsupported wall heights, large openings, or long-span cathedral ceilings.
- *Loading conditions*, such as high winds, high seismic risk, flood risks, coastal construction, heavy snows, or abnormal equipment loads.
- *Engineering certifications*, such as those required in V-zone flood areas and California seismic areas.
- *Nonconventional building systems or materials*, such as composite materials, structural steel, or unusual connections and fasteners.
- *Geotechnical or site conditions*, such as expansive soil, variable soil or rock foundation bearing, flood-prone areas, high water tables, or steeply sloped sites.
- *Owner's requirements*, such as special materials, appliance or fixture loads, atriums, and other special features.

Although some larger production builders produce sufficient volume to justify employing a full-time design professional, most builders use consultants on an as-needed basis. As more and more homes are built in earthquake-prone areas and along the hurricane-prone coastlines, however, the involvement of structural design professionals is increasing. The added complexities of larger custom-built homes and special site conditions further serve to spur demand for design professionals. Moreover, if nonconventional materials and methods of construction are to be used effectively, the services of a design professional are often required. In some instances, builders in high-hazard areas are using design professionals for onsite compliance inspection in addition to building design.

1.6 Housing Structural Performance

1.6.1 General

Of the more than 130 million housing units in the United States, approximately two-thirds are single-family dwellings. With that many units in service, a substantial number can be expected to experience performance problems, most of which amount to minor defects that are easily detected and repaired. Other performance problems, such as foundation problems related to subsurface soil conditions, are unforeseen or undetected and may not be realized for several years.

On a national scale, tens of thousands of homes are subjected to extreme climatic or geologic events in any given year. Of that number, some will be damaged because of events that exceed the performance expectations of the building code (that is, a direct tornado strike or a large-magnitude hurricane, thunderstorm, flood, or earthquake). In addition, some will experience problems resulting from defective workmanship, premature product failure, design flaws, or durability problems (that is, rot, termites, or corrosion). Often, a combination of factors leads to the most dramatic forms of damage. Because the cause and effect of these problems do not usually fit simple generalizations, it is important to consider cause and effect objectively in terms of the overall housing inventory.

The role of building codes historically has been to ensure that an acceptable level of safety is maintained during the life of a house to limit life-threatening performance problems. Because the public may not benefit from an excessive degree of safety, code requirements must also maintain a reasonable balance between affordability and safety. As implied by any rational interpretation of a building code or design objective, safety must include an accepted level of risk. In this sense, economy, energy efficiency, sustainability, and affordability may be broadly considered as competing performance requirements. For a designer, the challenge is to consider optimum value and to use cost-effective design methods that result in acceptable building performance in keeping with the intent of the building code. In many cases, designers may be able to offer cost-effective options to builders and owners that improve performance well beyond the expected norm. Owners, however, must understand that they carry the burden of risk beyond what is implied in the building built “to code”.

Building codes today are focusing more on life-cycle performance—including durability, sustainability, energy usage, and efficiency—in addition to life safety. These building code requirements include improved performance in response to normal and common occurrences such as water leaks, sagging floors, surface resistance to weathering, and temperature extremes. Building code requirements also include improved performance in response to less frequent occurrences such as floods, hurricanes, and earthquakes. The designer needs to be familiar with techniques to improve performance in all these situations to better serve the client.

1.6.2 Common Building Performance Issues

Common building performance issues have been found to include water intrusion of building envelopes; water intrusion to basements and foundations; building movements because of soil conditions; and failures of roof coverings, exterior claddings, and interior finishes.

These issues do not result solely from building products, because builders are often averse to products that are “too new.” Products and systems that have been the subject of class-action lawsuits in the United States give builders some reason to think twice about specifying new products. Examples of such products and systems include—

- Exterior Insulation and Finish Systems (EIFS).
- Fire-retardant-treated, or FRT, plywood roof sheathing.
- Certain composite sidings and exterior finishes.
- Polybutylene water piping.

Recent issues with heavily used products that had been long accepted (formaldehyde in wood products and contaminated drywall) have served to reinforce builders' concerns about product performance.

Note that many of these problems have been resolved by subsequent product improvements. It is unfortunately beyond the scope of this guide to give a complete account of the full range of problems experienced in housing construction.

1.6.3 Housing Performance in Hurricanes, Earthquakes, Floods, and Tornadoes

Scientifically designed studies of housing performance during natural disasters have permitted objective assessments of actual performance relative to that intended by building codes. Anecdotal damage studies, conversely, are often subject to notable bias. Both objective and subjective damage studies provide useful feedback to builders, designers, code officials, and others with an interest in housing performance. The issue of housing performance in high-hazard areas will continue to increase in importance, because nearly 50 percent of the U.S. population lives along coastlines, raising concerns about housing safety, affordability, and durability. Therefore, it is essential that housing performance be understood objectively as a prerequisite to guiding rational design and construction decisions. Proper design that takes into account the wind and earthquake loads discussed in chapter 3 and the structural analysis procedures addressed in chapters 4, 5, 6, and 7 will likely result in efficient designs that address the performance issues discussed in those chapters. Regardless of the efforts made in design, however, the intended performance can be realized only with an adequate emphasis on installed quality. For this reason, some builders in high-hazard areas have retained the services of design professionals as much for on-site compliance inspections as for their design services. This practice offers additional quality assurance to the builder, designer, and owner in high-hazard areas of the country. It is within these extreme events that most performance problems are observed, manifested, or exacerbated.

1.7 Summary

Housing in the United States has evolved over time under the influence of a variety of factors. Although available resources and the economy continue to

play significant roles, building codes, consumer preferences, and alternative construction materials are becoming increasingly important factors. In particular, building codes in the United States require homes in many special high-hazard areas to be designed by design professionals rather than by following prescriptive construction practices. This apparent trend may be attributed in part to changing perceptions regarding housing performance in these high-risk areas. Therefore, greater emphasis must be placed on the efficient structural design of housing. Although efficient design should also strive to improve construction quality through simplified construction, it also places greater importance on the quality of installation required to achieve the intended performance without otherwise relying on overdesign to compensate partially for real or perceived problems in installation quality.

1.8 References

- American Concrete Institute (ACI). 2011a. *Building Code Requirements for Structural Concrete and Commentary*. ACI Standard 318. Farmington Hills, MI: American Concrete Institute.
- . 2011b. *Building Code Requirements and Specifications for Masonry Structures and Companion Commentaries*. ACI Standard 530. Farmington Hills, MI: American Concrete Institute.
- American Plywood Association (APA). 2013. *Market Outlook and Regional Production*. APA Economics Report E79, 2013–2017. Tacoma, WA: American Plywood Association.
- American Society of Civil Engineers (ASCE). 2010. *Minimum Design Loads for Buildings and Other Structures*. ASCE Standard 7-10. Reston, VA: American Society of Civil Engineers.
- American Wood Council (AWC). 2012a. *National Design Specification for Wood Construction and Supplement*. Leesburg, VA: American Wood Council.
- . 2012b. *Wood Frame Construction Manual*. Leesburg, VA: American Wood Council.
- International Code Council (ICC). 2012a. *International Residential Code*, 2012 ed. Washington, DC: International Code Council.
- . 2012b. *International Building Code*, 2012 ed. Washington, DC: International Code Council.
- Portland Cement Association (PCA). 2012. *Prescriptive Design of Exterior Concrete Walls*. Skokie, IL: Portland Cement Association.
- U.S. Department of Health, Education and Welfare (HEW). 1931. *Light Frame House Construction*, Vocational Divisional Bulletin No. 145, U.S. Department of Health, Education and Welfare, Washington, DC.
- U.S. Department of Housing and Urban Development (HUD). 1994. *Alternative Framing Materials in Residential Construction: Three Case Studies*. Prepared by the NAHB Research Center, Inc., for the U.S. Department of Housing and Urban Development. Washington, DC: U.S. Department of Housing and Urban Development, Office of Policy Development and Research.

- . 1998a. *Insulating Concrete Forms: Installed Cost and Acoustic Performance*. Prepared by the NAHB Research Center, Inc., for the Portland Cement Association, National Association of Home Builders, and U.S. Department of Housing and Urban Development. Washington, DC: U.S. Department of Housing and Urban Development, Office of Policy Development and Research.
 - . 1998b. *Prescriptive Method for Insulating Concrete Forms in Residential Construction*. Prepared by the NAHB Research Center, Inc., for the Portland Cement Association, National Association of Home Builders, and U.S. Department of Housing and Urban Development. Washington, DC: U.S. Department of Housing and Urban Development, Office of Policy Development and Research.
- Wagner, Willis H. 2003. *Modern Carpentry—Building Construction Details in Easy-to-Understand Form*, 10th ed. South Holland, IL: Goodheart-Willcox Company, Inc.



CHAPTER 2

Structural Design Concepts

2.1 General

This chapter reviews some fundamental concepts of structural design and presents them in a manner relevant to the design of light-frame residential structures. Those concepts form the basis for understanding the design procedures and the overall design approach addressed in the remaining chapters of the guide. With this conceptual background, it is hoped that the designer will gain a greater appreciation for creative and efficient design of homes, particularly the many assumptions that must be made.

2.2 What Is Structural Design?

The process of structural design is simple in concept but complex in detail. It involves the analysis of a proposed structure to show that its resistance or strength will meet or exceed a reasonable expectation. That expectation usually is expressed by a specified load or demand and an acceptable margin of safety that constitutes a performance goal for a structure.

The performance goals of structural design are multifaceted. Foremost, a structure must perform its intended function safely over its useful life. Safety is discussed later in this chapter. The concept of useful life implies considerations of durability and establishes the basis for considering the cumulative exposure to time-varying risks (that is, corrosive environments, occupant loads, snow loads, wind loads, and seismic loads). Given that performance and cost are inextricably linked,

however, owners, builders, and designers must consider economic limits to the primary goals of safety and durability.

Maintaining the appropriate balance between the two competing considerations of performance and cost is a discipline that guides the “art” of determining value in building design and construction. Value is judged by the “eye of the beholder,” however, and what is an acceptable value to one person may not be acceptable to another (for example, too costly versus not safe enough or not important versus important). For this reason, political processes factor into the development of minimum goals for building design and structural performance, with minimum value decisions embodied in building codes and engineering standards that are adopted as law. Design codes and standards applicable to engineered and prescriptive light-frame residential design are developed by an open consensus format. Changes are proposed, a public comment and discussion period is provided, and then a vote of eligible voters is taken.

In view of the preceding discussion, a structural designer seems to have little control over the fundamental goals of structural design, except to comply with or exceed the minimum limits established by law. Although this statement, in general, is true, a designer can still do much to optimize a design through alternative means and methods that call for more efficient analysis techniques, creative design detailing, and the use of innovative construction materials and methods. Structural designers have flexibility within a specific building code or design standard, depending on the exact wording. The National Design Specifications (NDS, 2010), for example, advise against designing a system in which a wood member is put into cross-grain bending, but NDS does not specifically prohibit that design if engineering and mechanics principles are applied. *The FPL Wood Handbook* (FPL, 2010) provides guidance about those types of situations. One such approach that has gained significant momentum, particularly for seismic design, is performance-based design (PBD). PBD allows designers to explicitly consider the performance of a building during design and usually focuses on extreme loadings, such as wind (van de Lindt and Dao, 2009) or earthquake events (FEMA, 2012; Filiatrault and Folz, 2002), but PBD has recently been proposed for other types of loading (van de Lindt et al., 2009).

Although the balance between cost and safety is, of course, paramount for many types of construction, including one- and two-family dwellings, structural designers can communicate to the owner (and other building stakeholders) that products and construction details are available that can improve building performance, and those options should be considered beyond the minimum design required by law (often referred to as “above code”). One such example would be to add hurricane clips (a metal connector sold by commercial suppliers) between the double top plate of the light-frame wall and the roof truss or joist, even though the clips may not be required by the building code. The added wind resistance would help ensure vertical load path continuity (discussed later in this guide) during strong, straightline winds and, potentially, small tornadoes (see, for example, Prevatt et al., 2012 for further discussion).

In addition to exploring alternate means and methods such as PBD in the design of a residential wood-framed building, an engineered design calculated for a specific building configuration can be more cost effective than conventional

construction design. Engineered design can be detailed to perform better and to address specific requirements, such as those for a building that will be constructed with heavy roofing materials or a site that has expansive soil conditions.

In summary, the goals of structural design are generally defined by law and reflect the collective interpretation of general public welfare by those parties involved in the development and local adoption of building codes. A designer's role is to meet the goals of structural design as efficiently as possible and to satisfy a client's objectives within the intent of the building code. The designer must bring to bear the fullest extent of his or her abilities, including creativity, knowledge, experience, judgment, ethics, and communication—aspects of design that are within the control of the individual designer and integral to a comprehensive approach to design. Structural design is much, much more than simply crunching numbers.

2.3 Load Types and Whole Building Response

The concepts presented in this section provide an overview of building loads and their effect on the structural response of typical wood-framed homes. As shown in table 2.1, building loads can be divided into two types, based on the orientation of the structural actions or forces that they induce: vertical loads and horizontal (that is, lateral) loads.

TABLE 2.1 *Building Loads Categorized by Orientation*

Vertical Loads	Horizontal (Lateral) Loads
<ul style="list-style-type: none">• Dead (gravity)• Live (gravity)• Snow (gravity)• Wind (uplift on roof)• Seismic and wind (overturning)• Seismic (vertical ground motion)	<ul style="list-style-type: none">• Wind• Seismic (horizontal ground motion)• Flood (static and dynamic hydraulic forces)• Soil (active lateral pressure)• Tsunami (dynamic hydraulic and forces)

2.3.1 Vertical Loads

Gravity loads act in the same direction as gravity (that is, downward or vertically) and include dead, live, and snow loads. In general, they are static in nature and are usually considered a uniformly distributed or concentrated load. *Tributary area* is a term often used in design; it is the area of the building construction that is supported by a structural element, including the dead load (that is, weight of the construction) and the live load (that is, any applied loads). For example, the tributary gravity load on a floor joist would include the uniform floor load (dead and live) applied to the area of floor supported by the individual joist. The structural designer

would select a standard beam or column model to analyze bearing connection forces (that is, reactions), internal stresses (that is, bending stresses, shear stresses, axial stresses, and deflection), and stability of the structural member or system (refer to appendix A for beam equations). The selection of an appropriate analytic model, however, is no trivial matter, especially if the structural system departs significantly from traditional engineering assumptions that are based on rigid body and elastic behavior. Such departures from traditional assumptions are particularly relevant to the structural systems that comprise many parts of a house, but to varying degrees.

Wind uplift forces are generated by negative (suction) pressures acting in an outward direction from the surface of the roof in response to the aerodynamics of wind flowing over and around the building. As with gravity loads, the influence of wind uplift pressures on a structure or assembly (that is, roof) is analyzed by using the concepts of tributary areas and uniformly distributed loads. The major differences between wind uplift and gravity loads are that wind pressures act perpendicular to the building surface (usually not in the direction of gravity) and that pressures can vary according to the size of the tributary area and its location on the building, particularly with proximity to changes in geometry (for example, eaves, corners, and ridges). Even though the wind loads are dynamic and highly variable, the design approach is based on a maximum static load (that is, pressure) equivalent.

Vertical forces also are created by overturning reactions that result from wind and seismic lateral loads acting on the overall building and its lateral force-resisting systems (LFRSs). Earthquakes also produce vertical ground motions or accelerations that increase the effect of gravity loads; however, vertical earthquake loads are usually implicitly addressed in the gravity load analysis of a light-frame building.

2.3.2 Lateral Loads

The primary loads that produce *lateral forces* on buildings are attributable to forces associated with wind, earthquake ground motion, floods, soil, and, although rare, hurricane storm surge and tsunamis. Wind and earthquake lateral loads apply to the entire building. Lateral forces from wind are generated by positive wind pressures on the windward face of the building and by negative pressures on the leeward face of the building, creating a combined push-and-pull effect. Seismic lateral forces are generated by a structure's dynamic inertial response to ground movement which reverses back and forth in an irregular cyclic motion. The magnitude of the seismic shear (that is, lateral) load depends on the intensity of the ground motion, the building's mass, and the dynamic response characteristics of the building structure (that is, damping, ductility, stiffness, and so on). For houses and other similar lowrise structures, a simplified seismic load analysis employs equivalent static forces based on fundamental Newtonian mechanics ($F = ma$, or force = mass x acceleration), with adjustments to account for inelastic, ductile response characteristics of various building systems. Elevating structures on properly designed foundations can minimize flood loads, and avoiding building in a flood plain can eliminate flood loads altogether. Lateral loads from moving water and static hydraulic pressure are substantial. Soil lateral loads apply specifically to foundation wall design, mainly as an "out-of-plane" bending load on the wall.

Lateral loads also produce an *overturning* moment that must be offset by the dead load and connections of the building. Designers must, therefore, take into consideration the overturning forces on connections designed to restrain components from rotating or the building from overturning. Because wind is capable of generating simultaneous roof uplift and lateral loads, the uplift component of the wind load exacerbates the overturning tension forces that occur because of the lateral component of the wind load. Conversely, the dead load may be sufficient to offset the overturning and uplift forces, as is often the case in lower design wind conditions and in many seismic design conditions.

2.3.3 Structural Systems

As far back as 1948, it was determined that “conventions in general use for wood, steel and concrete structures are not very helpful for designing houses because few are applicable” (NBS, 1948). More specifically, the National Bureau of Standards (NBS, now the National Institute of Standards and Technology) document encouraged the use of more advanced methods of structural analysis for homes. The *International Residential Code* (IRC; ICC, 2012) has made improvements over the past decade, providing some engineering-based prescriptive solutions for structural designers. These solutions, in turn, allow better consistency in reliability across different components and subassemblies. Most of the prescriptive provisions in the IRC, however, are based on conventional construction (this topic will be discussed in more detail later in this chapter). Difficulties still exist in translating the results of studies of narrowly focused structural systems into general design applications for residential construction.

If a structural member is part of a *system*, as is typically the case in light-frame residential construction, its response is altered by the strength and stiffness characteristics of the system as a whole. In general, system performance includes two basic concepts known as *load sharing* and *composite action*. Load sharing is found in repetitive member systems (that is, wood framing) and reflects the ability of the load on one member to be shared by another or, in the case of a uniform load, the ability of some of the load on a weaker member to be carried by adjacent members. Composite action is found in assemblies of components that, when connected to one another, form a “composite member” with greater capacity and stiffness than the sum of the component parts.

The amount of composite action in a system depends on the manner in which the various system elements are connected. The aim is to achieve a higher effective section modulus than is provided by the individual component members. For example, when floor sheathing is nailed and glued to floor joists, the floor system realizes a greater degree of composite action than a floor with sheathing that is merely nailed; the adhesive between components helps prevent shear slippage, particularly if a rigid adhesive is used. Exact quantification of this result is difficult and beyond the scope of typical residential structural design. Slippage because of shear stresses transferred between the component parts necessitates consideration of partial composite action, which depends on the stiffness of an assembly’s connections. Consideration of the floor as a system of fully composite T-beams, therefore, may

lead to an unconservative solution, whereas the typical approach of considering only the floor joist member without taking into account the composite system effect will lead to a conservative design. For this reason, it is customary to consider the partial composite action of a glued-floor system only for computing deformation. Partial composite action is not considered for failure limit states.

This guide addresses the strength-enhancing effect of load sharing and partial composite action when information is available for practical design guidance. Repetitive-member increase factors (also called system factors) for general design have been quantified for a limited number of systems, such as floor systems and wall systems subjected to wind load. These system factors for general design use are necessarily conservative to cover a broad range of conditions. Exact quantification of system effects is a complex issue that would require extensive research, which has yet to be performed.

System effects do not only affect the strength and stiffness of light-frame assemblies (including walls, floors, and roofs). They also alter the classical understanding of how loads are transferred among the various assemblies of a complex structural system, including a complete wood-framed home. For example, floor joists are sometimes doubled under non-load-bearing partition walls because of the added dead load and resulting stresses, determined in accordance with accepted engineering practice. Such practice is based on a conservative assumption regarding the load path and the structural response. That is, the partition wall creates an additional load but is relatively rigid and can also act as a deep beam, particularly when the top and bottom are attached to the ceiling and floor framing, respectively. As the floor is loaded and deflects, the interior wall helps resist the load. In engineered wood design, the reliability of the load path is reasonably known. Engineered wood design often makes simplifying assumptions to limit cost and effort for the designers. These simplifications are typically included because (1) without them, increased engineering cost could exceed construction savings, and (2) analysis tools are not readily available to model complicated three-dimensional structural configurations.

The preceding example of the composite action illustrates occasions where the interaction of separate structural systems or subassemblies results in improved structural response of the floor system such that it is able to carry more dead and live load than if the partition wall were absent. Whole-house assembly testing has demonstrated this effect (Hurst, 1965). Hence, a double joist should not be required under a typical non-load-bearing partition; in fact, a single joist may not even be required directly below the partition, assuming that the floor sheathing is adequately specified to support the partition between the joists. Although this condition cannot yet be duplicated in a standard analytic form conducive to simple engineering analysis, a designer should be aware of the concept when making design assumptions regarding light-frame residential construction.

Over the past 15 years, an increasing number of whole-house tests have been performed to better understand load transfer between components and subassemblies during system response. A comprehensive whole-structure test program was conducted in Australia by the Commonwealth Scientific and Industrial Research Organization (CSIRO) (Foliente et al., 2000a, 2000b; Paevere et al., 2000). Filiatrault et al. (2002) tested a two-story wood-framed house as part of the Consortium of

Universities for Research in Earthquake Engineering-California Institute of Technology (CUREE-Caltech) project and later tested a larger two-story wood-framed building (Christovasilis, Filiatrault, and Wanitkorkal, 2007; Filiatrault et al., 2010) as part of the NEESWood project. Section 6.2 of the guide provides additional information on an array of whole-house tests conducted around the world.

At this point, consider that the response of a structural system, not just its individual elements, determines the manner in which a structure distributes and resists horizontal and vertical loads. For wood-framed systems, the departure from calculations based on classical engineering mechanics (that is, single members with standard tributary areas and assumed elastic behavior) and simplistic assumptions regarding load path can be substantial.

2.4 Load Path

Loads produce stresses on various systems, members, and connections as load-induced forces are transferred down through the structure to the ground. The path through which loads are transferred is known as the load path. A continuous load path is capable of resisting and transferring the loads that are realized throughout the structure from the point of load origination down to the foundation.

As noted, the load path in a conventional home may be extremely complex because of the structural configuration and system effects that can result in substantial load sharing, partial composite action, and a redistribution of forces that depart from traditional engineering concepts. In fact, such complexity is an advantage that often goes overlooked in typical engineering analyses.

Further, because interior non-load-bearing partitions typically are neglected in a structural analysis, the actual load distribution will differ from that assumed in an elementary structural analysis. A strict accounting of structural effects would require numerical tools that are not widely available and are potentially too expensive, as mentioned previously. To the extent possible, a designer should consider system effects, recognizing that inherent uncertainties exist that may make the results imprecise.

2.4.1 Vertical Load Path

Figures 2.1 and 2.2 illustrate vertically oriented loads created, respectively, by gravity and wind uplift. The wind uplift load originates on the roof from suction forces that act perpendicular to the exterior surface of the roof, as well as from internal pressure acting perpendicular to the interior surface of the roof-ceiling assembly in an outward direction. In addition, overturning forces resulting from lateral wind or seismic forces create vertical uplift loads (not shown in figure 2.2). In fact, a separate analysis of the lateral load path usually addresses overturning forces, necessitating separate overturning connections for buildings located in high-hazard wind or seismic areas (see section 2.3). As addressed in chapter 6, combining these vertical forces and designing a simple load path to accommodate wind uplift and overturning forces simultaneously may be feasible.

FIGURE 2.1 *Vertical Load Path for Gravity Loads*

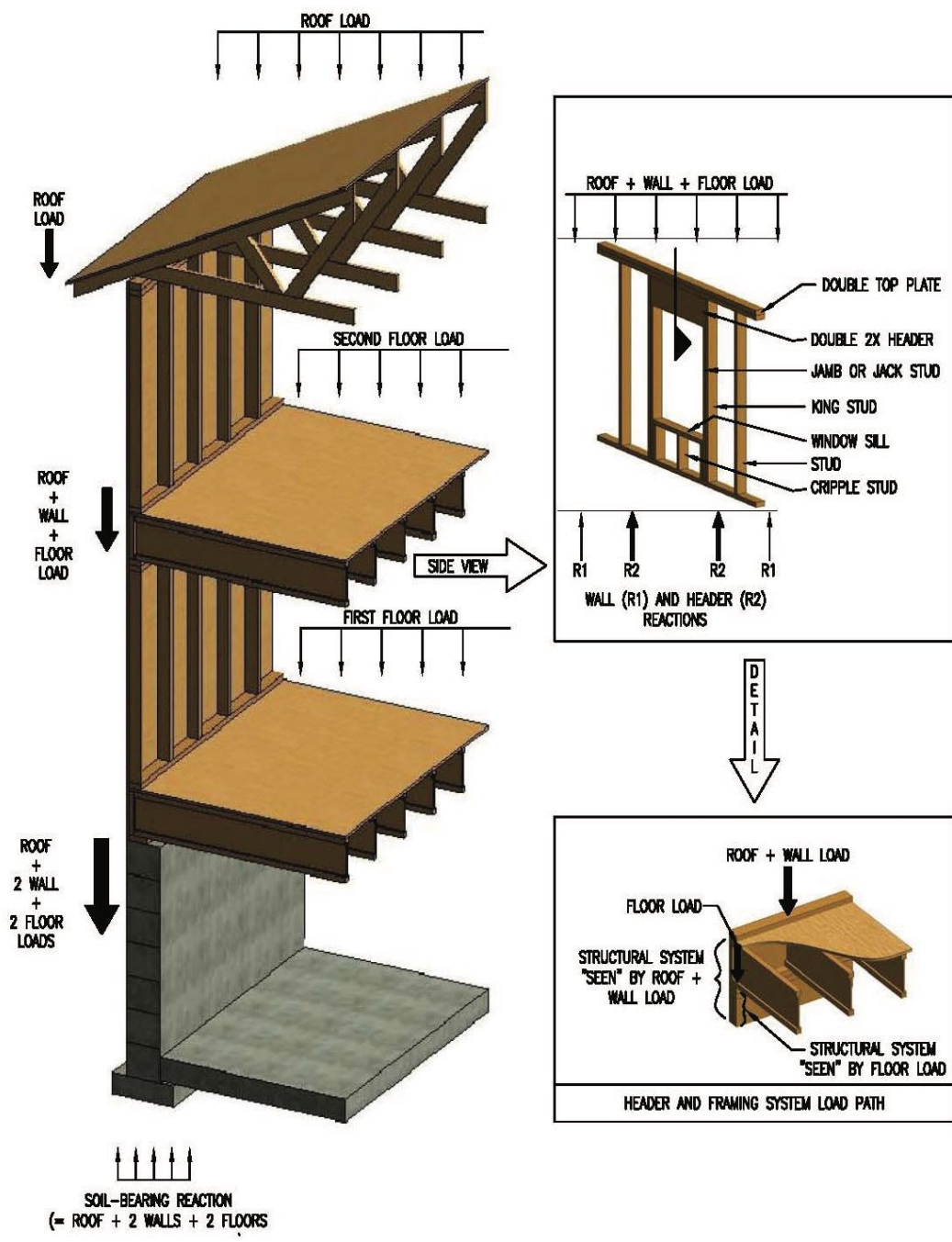
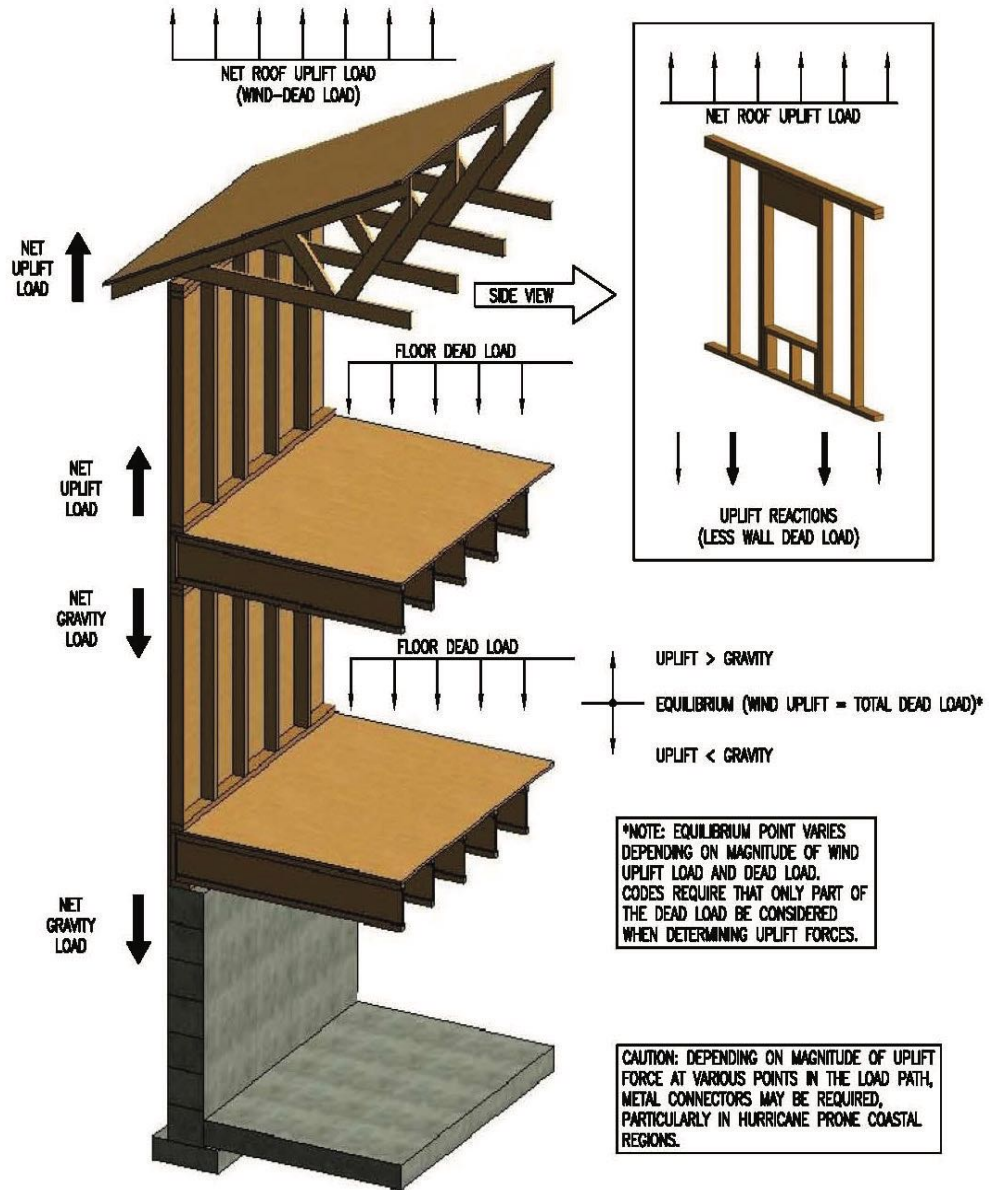

FIGURE 2.2

Vertical Load Path for Wind Uplift



In a typical two-story home, the load path for gravity loads and wind uplift involves the following structural elements—

- Roof sheathing.
- Roof sheathing attachment.
- Roof framing member (rafter or truss).
- Roof-to-wall connection.
- Second-story wall components (top plate, studs, sole plate, headers, wall sheathing, and their interconnections).
- Second-story-wall-to-second-floor connection.
- Second-story-to-first-story-wall connection.
- First-story wall components (same as second story).
- First-story-wall-to-first-story or foundation connection.
- First-story-to-foundation connection.
- Foundation construction.

The preceding list makes obvious that numerous members, assemblies, and connections must be considered when tracking the gravity and wind uplift load paths in a typical wood-framed home. The load path itself is complex, even for elements such as headers that are generally considered simple beams. Usually, the header is part of a structural system (see figure 2.1), not an individual element single-handedly resisting the entire load originating from above. A framing system around a wall opening, not just a header, constitutes a load path.

Figure 2.1 also demonstrates the need for appropriately considering the combination of loads as the load moves “down” the load path. Elements that experience loads from multiple sources (for example, the roof and one or more floors) can be significantly overdesigned if design loads are not proportioned or reduced to account for the improbability that all loads will occur at the same time. Of course, the dead load is always present, but the live loads are transient; even when one floor load is at its lifetime maximum, the others will likely be at only a fraction of their design load. Current design load standards generally allow for multiple transient load reductions; however, with multiple transient load-reduction factors intended for general use, those standards may not effectively address conditions relevant to a specific type of construction (that is, residential).

Consider the soil-bearing reaction at the bottom of the footing in figure 2.1. As implied by the illustration, the soil-bearing force is equivalent to the sum of all tributary loads, dead and live. However, it is important to understand the combined load in the context of design loads. Floor design live loads are based on a lifetime maximum estimate for a single floor in a single level of a building, but the occupancy conditions on the upper and lower stories in homes typically differ. When one load is at its maximum, the other is likely to be at a fraction of its maximum. Designers are able to consider the live loads of the two floors as separate transient loads; specific guidance is available in ASCE 7–10 (ASCE, 2010). In concept, the combined live load should be reduced by an appropriate factor, or one of the loads should be set at a point-in-time value that is a fraction of its design live load. For residential construction, the floor design live load is either 30 pounds per square foot (psf; for bedroom areas) or 40 psf (for other areas),

although some codes require a design floor live load of 40 psf for all areas. In contrast, average sustained live loads during typical use conditions are about 6 psf (with one standard deviation of 3 psf), which is about 15 to 20 percent of the design live load (Chalk and Corotis, 1980). If actual loading conditions are not rationally considered in a design, the result may be excessive footing widths, header sizes, and so forth.

When tracking the wind uplift load path (figure 2.2), the designer must consider the offsetting effect of the dead load as it increases down the load path. Building codes and design standards, however, do not permit the consideration of any part of the sustained live load in offsetting wind uplift, even though some minimum point-in-time value of floor live load is likely present if the building is in use—that is, furnished or occupied. In addition, other “nonengineered” load paths, such as those provided by interior walls and partitions, are not typically considered. Although these are prudent limits, they help explain why certain structures may not “calculate” but otherwise perform adequately.

Building codes commonly consider only 0.6 of the dead load when analyzing a structure’s net wind uplift forces. The 0.6 factor is a way of preventing the potential error of requiring insufficient connections where a zero uplift value is calculated in accordance with a nominal design wind load (as opposed to the ultimate wind event that is implied by the use of a safety margin for material strength in unison with a nominal design wind speed). Furthermore, building code developers have expressed a concern that engineers might overestimate actual dead loads, which would be conservative when designing members for gravity loads but unconservative when designing members for combined dead and wind loads.

For complicated house configurations, a load of any type may vary considerably at different points in the structure, necessitating a decision of whether to design for the worst case or to accommodate the variations. Often the worst case condition is applied to the entire structure even when only a limited part of the structure is affected. For example, a floor joist or header may be sized for the worst case span and used throughout the structure. The worst case decision is justified only when the benefit of a more intensive design effort is not offset by a significant cost reduction. Another important consideration is the more detailed analysis of various design conditions that usually results from greater construction complexity. Simplification and cost reduction are both important design objectives, but they may often be mutually exclusive. The consideration of system effects in design, as discussed previously, may result in both simplification and cost efficiencies that improve the quality and affordability of the finished product.

One helpful attribute of traditional platform-framed home construction is that the floor and roof gravity loads are typically transferred through bearing points, not connections. Thus, connections may contribute little to the structural performance of homes with respect to vertical loads associated with gravity (that is, dead, live, and snow loads).

By contrast, metal plate-connected roof and floor trusses rely on connections to resist gravity loads, but these engineered components are designed and produced in accordance with a proven standard and are generally highly reliable (TPI, 2007). Indeed, the metal plate-connected wood truss was first conceived in Florida in the 1950s to respond to the need for improved roof structural performance, particularly with respect to connections in roof construction (Callahan, 2002).

In high-wind climates, where the design wind uplift load approaches offsetting the actual dead load, the consideration of connection design in wood-framed assemblies becomes critical for roofs, walls, and floors (the dead load used to offset wind uplift is the actual dead load, not the design dead load). In fact, the importance of connections in conventionally built homes is evidenced by the common loss of weakly attached roof sheathing or roofs in extreme wind events, such as moderate- to large-magnitude hurricanes.

Newer prescriptive code provisions have addressed many of the historic structural wind damage problems by specifying more stringent general requirements (AWC, 2012; ICC, 2012). In many cases, the newer high-wind prescriptive construction requirements may be improved by more efficient site-specific design solutions that consider wind exposure and system effects and that include other analytic improvements. Site-specific design solutions may also improve prescriptive seismic provisions in the latest building codes for conventional residential construction (ICC, 2012).

2.4.2 Lateral Load Path

The overall system that provides lateral resistance and stability to a building is known as the LFRS. In light-frame construction, the LFRS includes shear walls and horizontal diaphragms. Shear walls are walls that are typically braced or clad with structural sheathing panels to resist racking forces. Horizontal diaphragms are floor and roof assemblies that are also usually clad with structural sheathing panels. Although more complicated and difficult to visualize, the lateral forces imposed on a building from wind or seismic action also follow a load path that distributes and transfers shear and overturning forces from lateral loads. The lateral loads of primary interest are those resulting from—

- The horizontal component of wind pressures on the building's exterior surface area.
- The inertial response of a building's mass and structural system to earthquake ground motions.

As seen in figure 2.3, the lateral load path in wood-framed construction involves entire structural assemblies (that is, walls, floors, and roofs) and their interconnections, not just individual elements or frames, as would be the case with typical steel or concrete buildings that use discrete braced framing systems. The distribution of loads in figure 2.3's three-dimensional load path depends on the relative stiffness of the various components, connections, and assemblies that constitute the LFRS. To complicate the problem further, stiffness is difficult to determine because of the nonlinearity of the load-displacement characteristics of wood-framed assemblies and their interconnections. Figure 2.4 illustrates a deformed light-frame building under lateral load (the deformations are exaggerated for conceptual purposes). Note, however, that American Society of Civil Engineers (ASCE) 7 (ASCE, 2010) does not require that torsion be included for wind load analyses for light-frame construction that is two stories or less; it is required only in seismic analyses.

FIGURE 2.3 *Lateral Load Path*

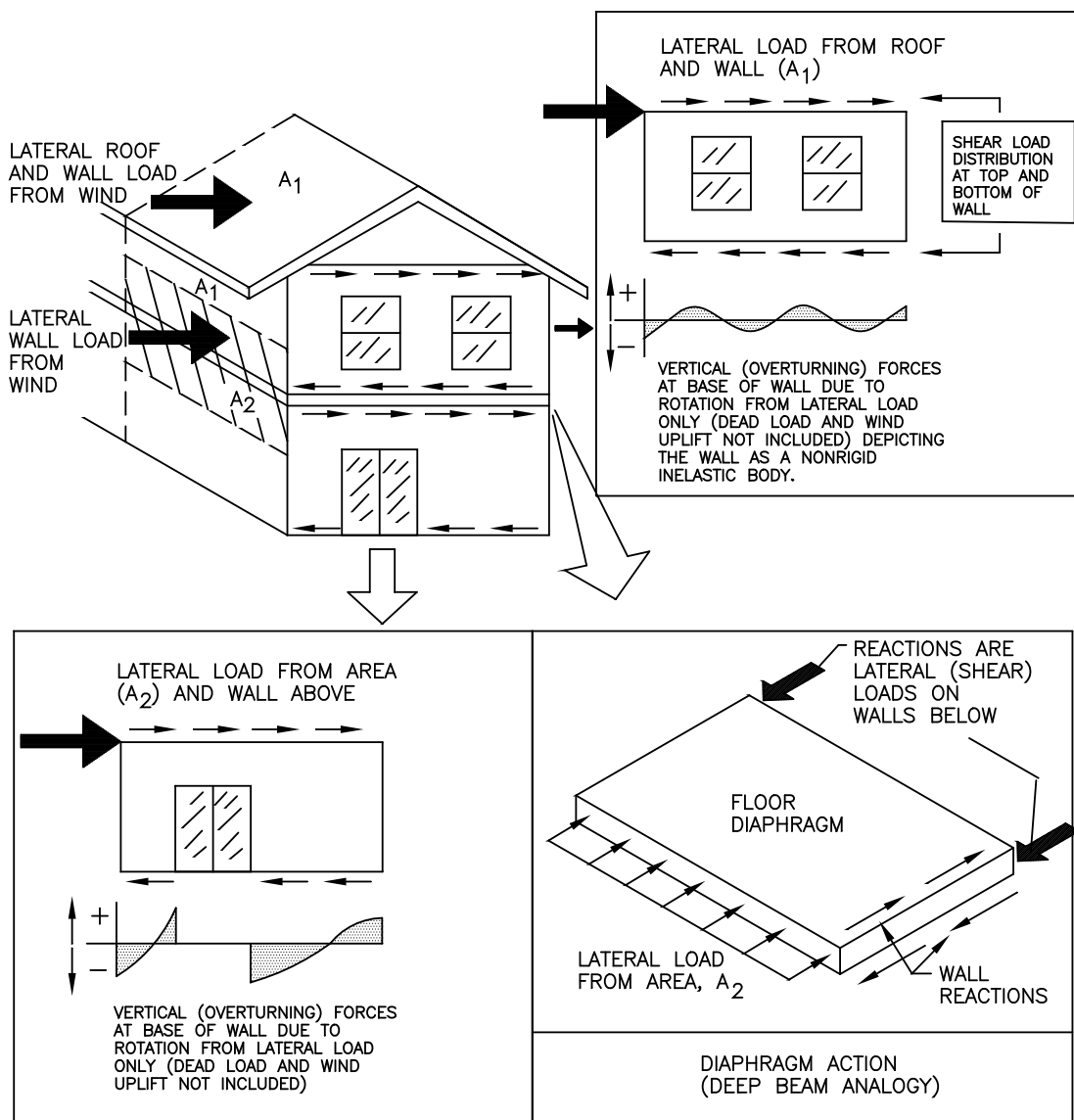

→ = LATERAL SHEAR (RACKING) LOAD FROM WIND PRESSURE ON WINDWARD AND LEEWARD (NOT SHOWN) TRIBUTARY AREAS. THE TRIBUTARY SURFACE PRESSURE LOADS ARE TRANSFERRED TO THE WALLS THROUGH THE FLOOR AND ROOF BY DIAPHRAGM ACTION.

NOTE: WHILE LATERAL LOADS ARE SIMILARLY TRANSFERRED TO WALLS BY DIAPHRAGM ACTION, SEISMIC FORCES ORIGINATE FROM THE TRIBUTARY MASS OF THE BUILDING (I.E., PLAN AREA), NOT THE EXTERIOR SURFACE AREA AS IS SHOWN FOR WIND.

FIGURE 2.4

Building Deformation Under Lateral Load

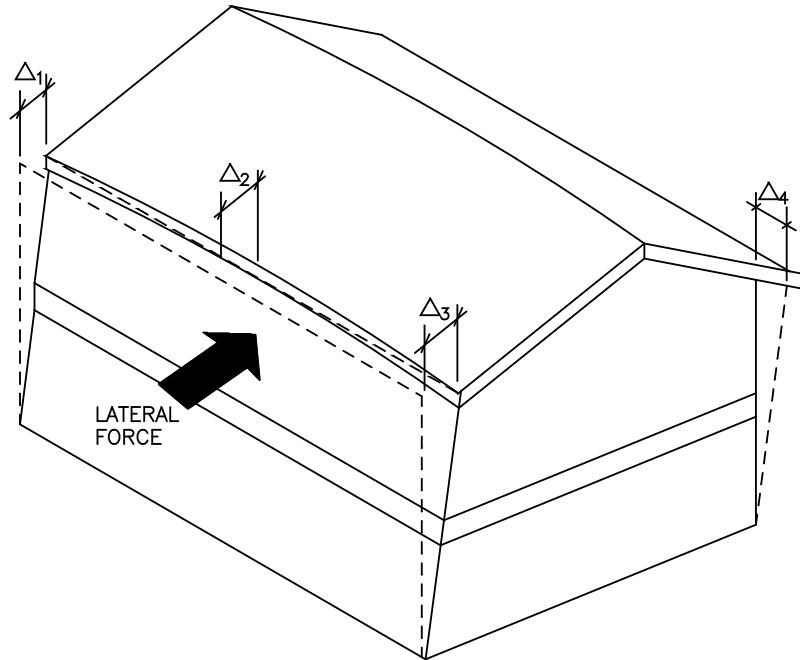

NOTE: IF STIFFNESS OR LOAD IS NONSYMMETRICAL, BUILDING ROTATION OCCURS ($\Delta_1 \neq \Delta_3$) AND LOADS ARE DISTRIBUTED BY TORSION ($\Delta_4 \neq 0$) AS WELL AS BY DIRECT SHEAR IN THE DIRECTION OF THE LATERAL FORCE. THIS CONDITION VARIES BUT IS A REALITY FOR MOST DESIGNS. Δ_2 IS THE BENDING DEFORMATION OF THE HORIZONTAL DIAPHRAGM (I.E., ROOF).

Lateral forces from wind and seismic loads also create overturning forces that cause a “tipping” or “rollover” effect. When these forces are resisted, a building is prevented from overturning in the direction of the lateral load. On a smaller scale, overturning forces are also realized at the shear walls of the LFRS such that the shear walls must be restrained from rotating or rocking on their base by proper connection. This is often done with anchor bolts or hold down hardware. On an even smaller scale, the forces are realized in the individual shear wall segments between openings in the walls.

The overturning force diagrams in Figure 2.3 are based on conventionally built homes constructed without hold-down devices positioned to restrain shear wall segments independently. It should be noted that the effect of dead loads that may offset the overturning force and of wind uplift loads that may increase the overturning force is not necessarily depicted in Figure 2.3’s conceptual plots of overturning forces at the base of the walls. If rigid steel hold-down devices are used in designing the LFRS, the wall begins to behave in a manner similar to a rigid body at the level of individual shear wall segments, particularly when the wall is broken into discrete segments as a result of the configuration of openings in a wall line.

Significant judgment and uncertainty attend the design process for determining building loads and resistance, including definition of the load path and the selection of suitable analytic methods. This guide is intended to serve as a resource for designers who are considering the use of alternative analytic methods when current approaches may not adequately address the design issue.

2.5 Structural Reliability

Before addressing the “nuts and bolts” of the structural design of single-family dwellings, one must understand the fundamental concept of structural reliability. Although safety is generally based on the rational principles of risk and probability theory known as structural reliability, it is also subject to some level of judgment, particularly the experience and understanding of those who participate in the development of building codes and design standards. Slight differences exist in the various code-approved sources for design loads, load combinations, load factors, and other features that can affect structural safety. National load and material design standards, however, have established a consistent basis for safety in structural design. It should be noted that residential occupancies are considered in the establishment of loads. Most importantly, the aim of any design approach is to ensure that the probability of failure (that is, load exceeding resistance) is acceptably small or, conversely, that the level of reliability is sufficiently high.

A common misconception is that design loads alone determine the amount of “safety” achieved in a design. For example, a typical conclusion reached in the aftermath of Hurricane Andrew was that the storm’s wind speed exceeded the design wind speed map value; therefore, the wind map (used as the source for the design load) was perceived to be insufficient. In other cases, such as the Northridge Earthquake, reaction to various anecdotal observations resulted in increased safety factors for certain materials (that is, wood design values were decreased by 25 percent by the City of Los Angeles). In reality, numerous factors affect the level of reliability

in a structural system, just as several factors determine the level of performance realized by buildings in a single extreme event, such as Hurricane Andrew or the Northridge Earthquake.

Structural reliability is a multifaceted performance goal that integrates all objective and subjective aspects of the design process, including the following major variables—

- Determination of characteristic material or assembly strength values based on tested material properties and their variabilities.
- Application of a nominal or design load based on a statistical representation of load data and the data's uncertainty or variability.
- Consideration of various uncertainties associated with the design practice (for example, competency of designers and accuracy of analytic approaches), the construction practice (for example, quality or workmanship), and durability.
- Selection of a level of reliability that considers the preceding factors and the consequences of exceeding a specified design limit state (that is, collapse, deformation, or the onset of “unacceptable” damage).

When the aforementioned variables are known or logically perceived, many ways are available to achieve a specified level of safety. As a practical necessity, however, the design process has been standardized to provide a reasonably consistent basis for applying the following key elements of the design process—

- Characterizing strength properties for various material types (for example, steel, wood, concrete, and masonry).
- Defining nominal design loads and load combinations for crucial inputs into the design process.
- Conveying an acceptable level of safety (that is, a safety margin) that can be easily and consistently applied by designers.

Institutionalized design procedures provide a basis for selecting from the vast array of structural material options available in the construction market. The generalizations necessary to address the multitude of design conditions, however, rely on a simplified and standardized format and thus often overlook special aspects of a particular design application.

The following sections discuss safety, but they are intentionally basic and focus on providing the reader with a conceptual understanding of safety and probability as a fundamental aspect of engineering. Probability concepts are fundamental to modern design formats, such as load and resistance factor design (LRFD), which is also known as reliability-based design or strength design. The same concepts are also crucial to understanding the implications of the simple safety factor in traditional allowable stress design (ASD). In 2002, the Committee on Reliability-Based Design of Wood Structures undertook a special project for the ASCE Structural Engineering Institute (SEI). The objective was to quantify the reliability inherent in AF&PA/ASCE 16 (1996) using state-of-the-art structural reliability

methods. The project resulted in a series of papers (Bulleit et al., 2004; Rosowsky et al., 2004; van de Lindt and Rosowsky, 2005). Several years later, the same committee completed another SEI special project that examined the feasibility of applying PBD principles to wood design (see chapter 1) (van de Lindt et al., 2009).

That study addressed both the benefits and the challenges. As discussed previously in this chapter, PBD concepts will be mentioned throughout this guide as an option for the structural designer to improve the performance of residential structures. Following are some additional references.

- *Probability Concepts in Engineering Planning and Design*. Vol. I, Basic Principles (Ang and Tang, 1975).
- *CRC Structural Engineering Handbook*. chap. 29, “Structural Reliability” (Chen, 1997).
- *Probabilistic Structural Mechanics Handbook: Theory and Industrial Applications* (Sundararajan, 1995).
- *Uncertainty Analysis, Loads, and Safety in Structural Engineering* (Hart, 1982).
- *Statistical Models in Engineering* (Hahn and Shapiro, 1967).
- *Reliability of Structures*, 2nd Ed. (Nowak and Collins, 2013).

2.5.1 Nominal Design Loads

Nominal design loads are generally specified on the basis of probability, with the interchangeable terms “return period” and “mean recurrence interval” often used to describe the probability of loads. Either term represents a condition that is predicted to be met or exceeded once, on average, during the reference time period. For design purposes, loads are generally evaluated in terms of annual extremes (that is, the variability of the largest load experienced in any given 1-year period) or maximum lifetime values.

The historical use of safety factors in ASD has generally been based on a 50-year return period design load. With the advent of LRFD, the calculation of nominal loads has shifted away from ASD for some load types. Now, earthquake and wind design use design values represented by hazard levels considered to be ultimate (or LRFD level) events. The Maximum Considered Earthquake is the intensity of ground motion that has the probability of exceedance of 2 percent in 50 years (for example, a 2,500-year return period). Earthquake design loads are based on a 2/3 factor of the ground motion that occurs during the 2,500-year event. They are computed from annual probabilities and design periods and is expressed as $P = 1 - (1 - P_a)^n$ where P_a is the annual probability (1/return period), P is the probability of exceedance during the time period of interest, and n is the time period of interest. This formula is described in the commentary of ASCE 7–10.

ASCE 7–10 (ASCE, 2010) provides risk-targeted seismic design maps for the conterminous United States (Luco et al., 2007). One key result of the move from uniform-hazard to risk-targeted mapped spectral accelerations is a reduction in the design spectral acceleration for the central and eastern United States to 70 to 90

percent of their 2005 values. This reduction occurred because previous mapping considered only the magnitude of the event, not the likely frequency.

The method of determining a design load also differs according to the type of load and the availability of data to evaluate the time-varying nature of loads. The derivation of various nominal loads may be assembled from information and references contained in the ASCE 7 standard (ASCE, 2010). Design wind loads are based on a probabilistic analysis of wind speed data collected from many weather stations across the United States. The data include wind loads in most of the country and hurricane simulation modeling for wind speeds along the hurricane-prone coastlines. The wind speed maps in ASCE 7–10 represent the speeds that have a 7-percent probability of exceedance in 50 years, or a 700-year return period for residential structures (see section 3.6 on wind design). Snow loads are based on snowfall or ground snow depth data and are correlated to roof snow loads through recent studies. Snow drift loads in ASCE 7–10 (ASCE, 2010) have improved from earlier versions of the standard by adding a new thermal factor and by not requiring unbalanced snow loads be applied to hip and gable roofs when the roof slope is steeper than 7 on 12 or is shallower than ½ on 12 (1/2:12).

Earthquake loads are defined from historical ground motion data and conceptualized risk models based on direct or indirect evidence of past earthquake activity. The maps that illustrate the seismic ground motion have been developed by the U.S. Geological Survey. Considerable uncertainty exists in the estimation of seismic hazards, particularly in areas that are believed to have low seismicity (that is, few events) but the potential for major seismic events. Details of the ASCE 7–10 map development can be found in Luco et al. (2007). Floor live loads are modeled by using live load surveys of “point-in-time” loading conditions and hypotheses or judgment concerning extreme or maximum lifetime loads. In some cases, expert panels decide on appropriate loads or related load characteristics when adequate data are not available.

In summary, the determination of load characteristics is based on historical data, risk modeling, and expert opinion. Those factors, in turn, guide the specification of nominal design loads for general design purposes in both the ASD and LRFD formats. It is important to remember that the return period of the design load is not the only factor determining safety; the selection of safety factors (ASD), load factors (LRFD), or performance objectives depends on the definition of a nominal design load (that is, its return period) and the material’s strength characterization to achieve a specified level of safety.

2.5.2 Basic Safety Concepts in Allowable Stress Design

The concept of ASD is demonstrated in a generic design equation or performance function (see equation 2.5-1) for a wood framing member. A common practice in traditional ASD is to divide the characteristic (for example, fifth percentile) material strength value by a safety factor of greater than 1 to determine an allowable design strength that is dependent on a selected limit state (that is, a proportional limit or rupture) and material type, among other factors that involve the

judgment of specification-writing groups. Most factors of safety fall in the range of 1.5 to 2.5 for residential design. The allowable design strength is then compared to the stresses created by a nominal design load combination, usually based on a 50-year mean recurrence interval. A lower safety factor is generally applied to design conditions that are less variable or that are associated with a “noncritical” consequence, while the higher safety factor is typically applied to elements associated with greater uncertainty, such as connections. In addition, a higher safety factor is usually selected for materials, systems, or stress conditions that result in an abrupt failure mode without warning. The safety factor is also intended to cover the variability in loads in ASD.

Equation 2.5-1

$$\frac{R}{S.F.} \geq L$$

where,

- R = the nominal resistance (or design stress), usually based on the fifth percentile strength property of interest (also known as the characteristic strength value).
- S.F. = the safety factor (R/S.F. is known as the allowable stress).
- L = the load effect caused by the nominal design load combination (in units of R).

The equation refers to characteristic material strength, which represents the material stress value used for design purposes (also known as nominal or design strength or stress). When characteristic material strength (normalized to standard conditions) is divided by a safety factor, the result is an allowable material strength or stress. Given that materials exhibit variability in their stress capacity (some more variable than others), it is necessary to select a statistical value from the available material test data. Generally, but not always, the test methods, data, and evaluations of characteristic material strength values follow standardized procedures that vary across material industries (for example, concrete, wood, and steel) in part because of the uniqueness of each material. In most cases, the characteristic strength value is based on a lower bound test statistic such as the fifth percentile, which is a value at which no more than 5 percent of the material specimens from a sample exhibit a lesser value. Because sampling is involved, the sampling methodology and sample size become critical to confidence in the characteristic strength value for general design applications.

In some cases, procedures for establishing characteristic material strength values are highly sophisticated and address many of the concerns mentioned previously; in other cases, the process is simple and involves reduced levels of exactness or confidence (for example, use of the lowest value in a small number of tests). Generally, the more variable a material, the more sophisticated the determination of characteristic material strength properties. A good example is the wood industry, whose many species and grades of lumber further complicate the

inherent nonhomogeneity of the product. The wood industry, therefore, uses fairly sophisticated procedures to sample and determine strength properties for a multitude of material conditions and properties (see chapter 5).

2.5.3 Basic Safety Concepts in Load and Resistance Factor Design

The LRFD format has been conservatively calibrated to the level of safety represented by past ASD design practice and thus retains a tangible connection with historically accepted norms of structural safety (Ellingwood et al., 1982; Galambos et al., 1982; and others);¹ thus, either method achieves a similar level of safety. The LRFD approach, however, uses two factors—one applied to the load and one applied to the resistance or strength property—that permits more consistent treatment of safety across a broader range of design conditions.

Equation 2.5-2 shows, conceptually, the LRFD design format (that is, performance function) and compares a factored characteristic resistance value with a factored nominal load. Thus, for a given hazard condition and given material—and similar to the outcome described in the previous section on ASD—increasing the load factor or decreasing the resistance factor has the effect of increasing the level of safety. Figure 2.5 depicts the variable nature of building loads and resistance and the safety margin relative to design loads and nominal resistance.

¹Historically accepted performance of wood-framed design, particularly housing, has not been specially considered in the development of modern LRFD design provisions for wood or other materials (such as concrete in foundations).

Equation 2.5-2

$$\phi R \geq \sum \gamma L$$

where,

ϕ = resistance factor (phi).

R = nominal resistance or design stress, usually based on the fifth percentile strength property of interest (also known as the characteristic strength value).

γ = load factor for each load in a given load combination (gamma).

L = the stress created by each load in a nominal design load combination (in units of R).

A resistance factor is applied to a characteristic material strength value to account for variability in material strength properties. The resistance factor generally ranges from 0.5 to 0.9, with the lower values applicable to those strength properties that have greater variability or that are associated with an abrupt failure (one with little warning). The resistance factor also depends on the selected characterization of the nominal or characteristic strength value for design purposes (that is, average, lower fifth percentile, lowest value of a limited number of tests, and so on).

A load factor is individually applied to each load in a nominal design load combination to account for the variability and nature of the hazard or combined hazards. It also depends on the selected characterization of the nominal load for design purposes (for example, 50-year return period, 475-year return period, or others). In addition, the load factors proportion the loads relative to each other in a combination of loads (that is, account for independence or correlation between loads and their likely “point-in-time” values when one load assumes a maximum value). Thus, the load factor for a primary load in a load combination is generally 1.0 in LRFD. For other transient loads in a combination, the factors are generally much less than 1. In this manner, the level of safety for a given material and nominal design load is determined by the net effect of factors—one on the resistance side of the design equation and the others on the load side. For ASD, the factors and their purpose are embodied in one simple element the safety factor.

FIGURE 2.5

Basic Concept of Safety in LRFD and ASD Considering the Variability of Loads and Resistance

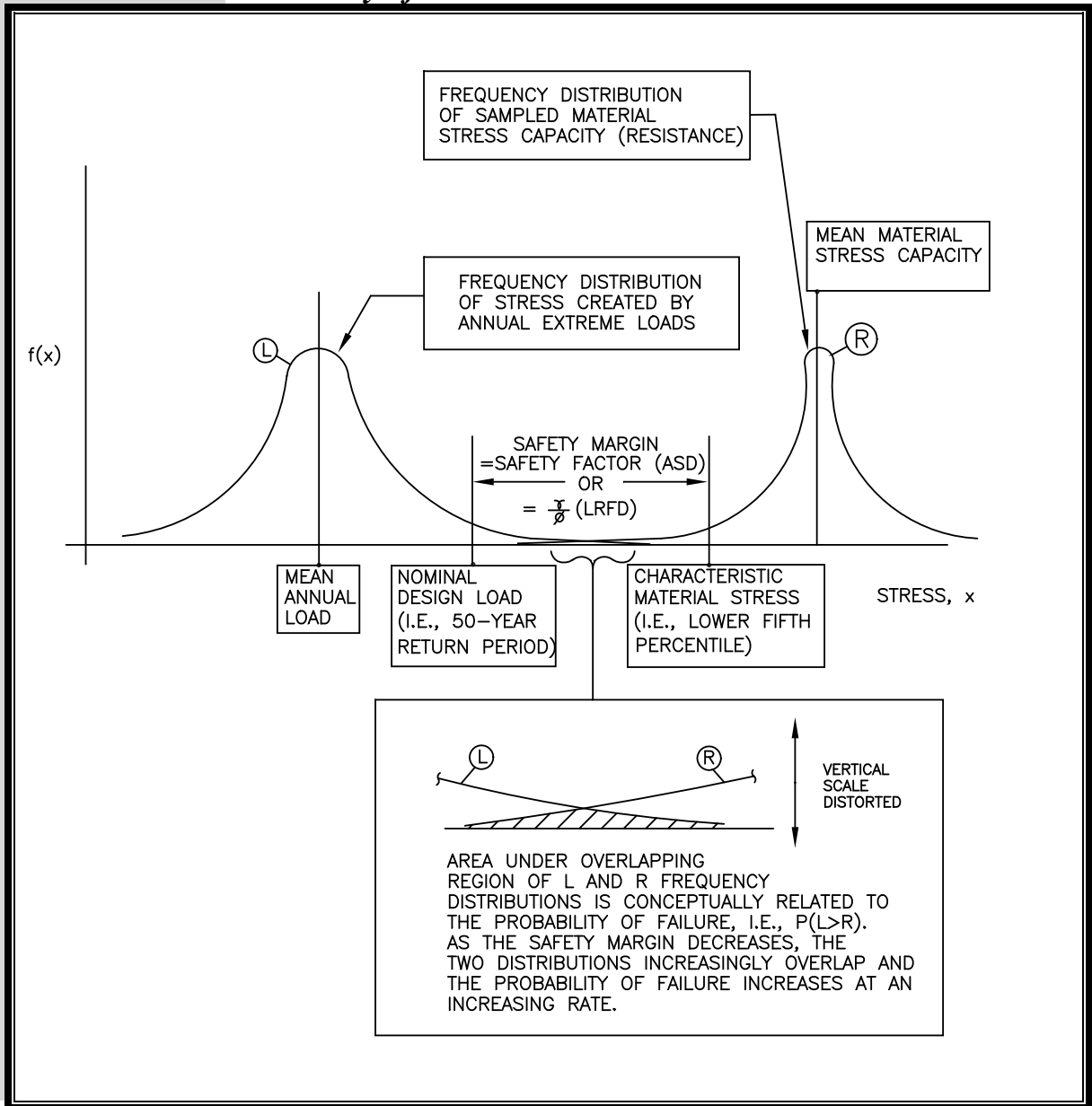

2.5.4 Basic Safety Concepts in Performance-Based Design

PBD is a design approach or methods that allow the designers (or team) to explicitly consider performance objectives during the design process. An ASCE special project, titled “The Next Step for AF&PA/ASCE 16: Performance-Based Design of Wood Structures,” was recently completed (van de Lindt et al., 2009). PBD has been documented for several decades and has its origin in fire engineering, for which the objective is product development that meets a particular prescribed

performance, for example, a 1-hour fire rating. Earthquake engineering followed suit with the Structural Engineers Association of California Vision 2000 (1996) document after the 1989 Loma Prieta and 1994 Northridge earthquakes. The primary seismic PBD methodology is described in FEMA P-58, *Seismic Performance Assessment of Buildings: Methodology and Implementation* (FEMA, 2012). The difference in this design approach is in the consideration of outcomes of the design when a defined hazard level determines the design of the building. Designs based on building codes follow defined criteria in the codes that are intended to provide some level of performance; however, that performance level is never stated and is seldom evaluated except when the building is affected by a design event (FEMA, 2012). Designs based on performance are based on desired outcomes and levels of building performance during and after an event occurs. The beginning points for PBD are the needs of the building owners or stakeholders, not the requirements of the building code.

Although not in widespread use as of this revision of the guide, PBD for wind engineering has been envisioned (van de Lindt and Dao, 2009). Work has begun in wind engineering using as a starting point the process developed for the seismic hazard. The building designs that follow will likely be different for the two hazards, given that seismic designs usually are driven by collapse prevention techniques for extreme events, and wind designs may be driven by preventing weather penetration into the building envelope.

2.5.5 Putting Safety and Performance into Perspective

Safety is a relative measure that must be interpreted in consideration of the many assumptions underlying the treatment of uncertainty in the design process. Any reliable measure of safety must look to past experience and attempt to evaluate historic data in a rational manner to predict the future. Economic consequences are becoming increasingly debated and influential in the development of codified guidelines for structural design, which, as discussed previously, has led to the development of PBD in the seismic arena. Of course, such a design philosophy explicitly considers the performance objectives for a structure.

Implicit consideration of building performance also has been routinely achieved through improved building codes and standards. For example, following Hurricane Charley (2004), the Institute for Business and Home Safety (IBHS) concluded that “enforcement of modern engineering design based building codes made a positive impact on the performance of residential homes during Hurricane Charley in 2004. The frequency of claims was reduced by 60 percent and the claim was 42 percent less severe when a loss did occur, for homes built after the adoption of the modern codes,” (IBHS, 2004: pg. 5). For more information on residential building codes and enforcement, see IBHS (2011). Thus, some engineering requirements in codes may address two very different objectives—life safety and property protection or damage reduction. Finally, the manner in which these two different forms of risk are presented can have a profound impact on the perspective of risk and the perceived need for action or inaction.

2.6 References

- American Wood Council (AWC). 2012. *Wood Frame Construction Manual*. Washington, DC: American Wood Council.
- . 2010. *National Design Specifications (NDS)*. Washington, DC: American Wood Council.
- Ang, Alfredo H. S., and Wilson H. Tang. 1975. *Probability Concepts in Engineering Planning and Design*. Vol. I, *Basic Principles*. New York: John Wiley & Sons.
- American Society of Civil Engineers (ASCE). 2010. *Minimum Building Loads for Buildings and Other Structures (ASCE 7–10)*. Reston, VA: American Society of Civil Engineers.
- Bulleit et al. 2005. “Modeling Wood Walls Subjected to Combined Transverse and Axial Loads.” *Journal of Structural Engineering* 131, No. 5: 781–793. Reston, VA: ASCE.
- Callahan, Edward E. 2002. *Metal Plate Connected Wood Truss Handbook*. 3rd ed. Madison, WI: Wood Truss Council of America.
- Chalk, P. and R. Corotis. 1980. “Probability Model for Design Live Loads.” *Journal of the Structural Division* 106, No. 10: 2017–2033. Reston, VA: ASCE.
- Chen, W.F. 1997. “Structural Reliability.” Chap. 29 in *Structural Engineering Handbook*. Boca Raton, FL: CRC Press.
- Christovasilis, I. P., A. Filiatrault, and A. Wanitkorkal. 2007. “Seismic Test of a Full-Scale Two-Story Light-Frame Wood Building: The NEESWood Benchmark Test.” NEESWood report NW-01, MCEER, Buffalo, NY.
- Ellingwood, B., J. G. MacGregor, T. V. Galambos, and C. A. Cornell. 1982. “Probability Based Load Criteria: Load Factors and Load Combinations.” *Journal of the Structural Division*, 108, No. 5: 978–997.
- Federal Emergency Management Agency (FEMA). 2012. *Seismic Performance Assessment of Buildings: Methodology and Implementation (FEMA P-58)*. Washington, DC: FEMA.
- Filiatrault, A., and Folz, B., 2002. “Performance-Based Seismic Design of Wood Framed Buildings”, *Journal of Structural Engineering*, 128, No.1, 39-47.

- Filiatrault, A., D. Fischer, B. Folz, and C-M. Uang. 2002. “Seismic Testing of a Two-Story Woodframe House: Influence of Wall Finish Materials.” *Journal of Structural Engineering* 128, No. 10: 1337–1345.
- Filiatrault, A., I. P. Christovasilis, A. Wanitkorkal, and J. W. van de Lindt. 2010. “Experimental Seismic Response of a Full-Scale Light-Frame Wood Building.” *Journal of Structural Engineering* 136, No. 3: 246–254.
- Foliente, G. C., B. Kasal, P.J. Paevere, and M. Collins. 2000a. “Whole Structure Testing and Analysis of a Light-Frame Wood Building: Phase II—Design Procedures against Lateral Loads. BCE Doc 00/177. CSIRO, Highett, Victoria, Australia.
- Foliente, G. C., B. Kasal, P. J. Paevere, L. Macindoe, R. Banks, M. Syme, C. Seath, and M. Collins. 2000b. “Whole Structure Testing and Analysis of a Light-Frame Wood Building: Phase I—Test House Details and Preliminary Results.” BCE Doc 00/033. CSIRO, Highett, Victoria, Australia.
- Forest Products Laboratory. 2010. “Wood handbook—Wood as an engineering material.” General Technical Report FPL-GTR-190. Madison, WI: U.S. Department of Agriculture, Forest Service, Forest Products Laboratory.
- Galambos, T. V., et al.. 1982. “Probability Based Load Criteria: Assessment of Current Design Practice.” *Journal of the Structural Division* 108, No. 5: 959–977.
- Hahn, G. J., and S. S. Shapiro. 1967. *Statistical Models in Engineering*. New York: John Wiley & Sons.
- Hart, Gary C. 1982. *Uncertainty Analysis, Loads, and Safety in Structural Engineering*. Englewood Cliffs, NJ: Prentice-Hall, Inc.
- Hurst, Homer T. 1965. *The Wood-Frame House as a Structural Unit*. Technical Report No. 5, National Forest Products Association, Washington, DC.
- Institute for Business and Home Safety (IBHS). 2004. “Hurricane Charley: Nature’s Force vs. Structural Strength—Executive Summary” Hurricane Charley Post-Hurricane Report, IBHS, Tampa, FL.
- . 2011. “Rating the States: An Assessment of Residential Building Code and Enforcement Systems for Life Safety and Property Protection in Hurricane-Prone Regions.” IBHS.
- International Code Council (ICC). 2012. *International Residential Code*. Washington, DC: ICC.

- Luco, N., B. R. Ellingwood, R. O. Hamburger, J. D. Hooper, and J. K. Kimball. 2007. Proceedings of the 2007 Convention of the Structural Engineers Association of California, Sacramento, CA.
- National Bureau of Standards (NBS). 1948. *Strength of Houses: Application of Engineering Principles to Structural Design*. Building Materials and Structures Report 109, U.S. Department of Commerce, National Bureau of Standards. Washington, DC: GPO.
- Nowak, A. S., and K. R. Collins. 2013. *Reliability of Structures*, 2nd ed. Boca Raton, FL: CRC Press.
- Paevere, P. J., G. C. Foliente, L. Macindoe, R. Banks, M. Syme, C. Seath, B. Kasal, and M. Collins. 2000. "Whole Structure Testing and Analysis of a Light-Frame Wood Building: Phase III—Destructive Testing." BCE Doc 00/425. CSIRO, Highhett, Victoria, Australia.
- Prevatt et al. 2012. Making the case for improved structural design: Tornado outbreaks of 2011. *Leadership and Management in Engineering* 12 (4), 254-270.
- Rosowsky, D. V., Y. Guangren, and W. M. Bulleit, 2005. "Reliability of Light-Frame Wall Systems Subject to Combined Axial and Transverse Loads." *Journal of Structural Engineering*, 131, No. 9: 1444-1455.
- Structural Engineers Association of California Vision 2000. 1995. SEAOC (1995). "Vision 2000—A Framework for Performance Based Earthquake Engineering." Vol. 1, January 1995.
- Sundararajan, C. 1995. *Probabilistic Structural Mechanics Handbook: Theory and Industrial Applications*. New York: Chapman & Hall.
- Truss Plate Institute (TPI). 2007. TPI 1: *National Design Standard for Metal Plate Connected Wood Truss Construction*. Truss Plate Institute, Madison, WI.
- van de Lindt, J. W., Y. Li, W.M. Bulleit, R. Gupta, and P. I. Morris. 2009. "The Next Step for ASCE 16: Performance-Based Design of Wood Structures." *Journal of Structural Engineering*, 135, No. 6: 611–618.
- van de Lindt, J.W., Y. Li, W.M. Bulleit, R. Gupta, and P. I. Morris. (2009). "The Next Step for ASCE 16: Performance-Based Design of Wood Structures." *Journal of Structural Engineering*, 135, No. 6: 611- 618.
- van de Lindt, J. W. and T. N. Dao. 2009. "Performance-Based Wind Engineering for Wood Frame Buildings." *Journal of Structural Engineering*, 135, No. 2: 169–177.

van de Lindt, J.W. and D. V. Rosowsky. 2005. “Strength-Based Reliability of Wood Shearwalls Subjected to Wind Load.” *Journal of Structural Engineering*, 131, No. 2: 359-363.

CHAPTER 3

Design Loads for Residential Buildings

3.1 General

Loads are a primary consideration in any building design because they define the nature and magnitude of hazards or external forces that a building must resist to provide reasonable performance (that is, safety and serviceability) throughout the structure's useful life. The anticipated loads are influenced by a building's intended use (occupancy and function), configuration (size and shape), and location (climate and site conditions). Ultimately, the type and magnitude of design loads affect critical decisions such as material selection, construction details, and architectural configuration. To optimize the value (that is, performance versus economy) of the finished product, therefore, design loads must be applied realistically.

Although the buildings considered in this guide are primarily single-family detached and attached dwellings, the principles and concepts related to building loads also apply to other similar types of construction, such as low-rise apartment buildings. In general, the design loads recommended in this guide are based on applicable provisions of the ASCE 7 standard—*Minimum Design Loads for Buildings and Other Structures* (ASCE, 2010). The ASCE 7 standard represents an acceptable practice for building loads in the United States and is recognized in U.S. building codes. For this reason, the reader is encouraged to become familiar with the provisions, commentary, and technical references contained in the ASCE 7 standard.

In general, the structural design of housing has not been treated as a unique engineering discipline or subjected to a special effort to develop better, more efficient design practices. For that reason, this part of the guide focuses on those aspects of ASCE 7 and other technical resources that are particularly relevant to the determination of design loads for residential structures. The guide provides supplemental design assistance to address aspects of residential construction for which current practice is either silent or in need of improvement. The guide's

methods for determining design loads are complete yet tailored to typical residential conditions. As with any design function, the designer must ultimately understand and approve the loads for a given project as well as the overall design methodology, including all its inherent strengths and weaknesses. Because building codes from different jurisdictions can vary in their treatment of design loads, the designer should, as a matter of due diligence, identify variances from both local accepted practice and the applicable building code relative to design loads as presented in this guide, even though the variances may be considered technically sound.

Complete design of a home typically requires the evaluation of several different types of materials, as discussed in chapters 4 through 7. Some material specifications use the allowable stress design (ASD) approach while others use load and resistance factor design (LRFD). Chapter 4 uses the LRFD method for concrete design and the ASD method for masonry design. For wood design, chapters 5, 6, and 7 use ASD. For a single project, therefore, the designer may have to determine loads in accordance with both design formats. This chapter provides load combinations intended for each method. The determination of individual nominal loads is essentially unaffected. Special loads, such as ice loads and rain loads, are not addressed herein. The reader is referred to the ASCE 7 standard and applicable building code provisions regarding special loads.

3.2 Load Combinations

The load combinations in table 3.1 are recommended for use with design specifications based on ASD and LRFD. Load combinations provide the basic set of building load conditions that should be considered by the designer. They establish the proportioning of multiple transient loads that may assume point-in-time values when the load of interest attains its extreme design value. Load combinations are intended as a guide to the designer, who should exercise judgment in any particular application. The load combinations in table 3.1 are appropriate for use with the design loads determined in accordance with this chapter.

The principle used to proportion loads is a recognition that when one load attains its maximum lifetime value, the other loads assume arbitrary point-in-time values associated with the structure's normal or sustained loading conditions. The advent of LRFD has drawn greater attention to this principle (Ellingwood et al., 1982; Galambos et al., 1982). The proportioning of loads in this chapter for ASD is consistent with design load specifications such as ASCE 7. ASD load combinations found in building codes typically have included some degree of proportioning (that is, $D + W + 1/2S$) and usually have made allowance for a special reduction for multiple transient loads. Some earlier codes also have permitted allowable material stress increases for load combinations involving wind and earthquake loads. None of these adjustments for ASD load combinations are recommended for use with table 3.1 because the load proportioning is considered sufficient. However, allowable material stress increases that are based upon the duration of the load (that is, wood members under wind loading) may be combined with load proportioning.

Note also that the wind load factor of 1.0 in table 3.1 used for LRFD is consistent with current wind design practice and now recognizes ultimate wind loads when the speeds illustrated in the ASCE 7-10 maps are used. The return period of the design wind speeds for residential buildings along the hurricane-prone coast is now

700 years, and this long return period provides a consistent risk basis for wind design across the country. Many elements of residential design continue to use ASD design level wind speeds, however, primarily because of how products have been tested, rated, and marketed to the industry. Some prescriptive design documents such as the Wood Frame Construction Manual (WFCM) continue to use ASD load combinations in the development of loads provided in the design tables of that document (AWC, 2012). The conversion of LRFD speeds to ASD speeds is $ASD \text{ speed} = LRFD \text{ speed} \times 0.6$. The conversion of LRFD pressures to ASD pressures is $ASD \text{ wind pressure} = LRFD \text{ pressure} \times 0.6$ (the ASD wind load factor). The load factor changes used in ASCE 7-10 are referenced in the 2012 editions of the building codes where ASCE 7-10 is referenced.

The load combinations in table 3.1 are simplified and tailored to specific application in residential construction and the design of typical components and systems in a home. These or similar load combinations often are used in practice as shortcuts to those load combinations that govern the design result. This guide makes effective use of the shortcuts and demonstrates them in the examples provided later in the chapter. The shortcuts are intended only for the design of residential light-frame construction.

TABLE 3.1

Typical Load Combinations Used for the Design of Components and Systems¹

Component or System	ASD Load Combinations	LRFD Load Combinations
Foundation wall (gravity and soil lateral loads)	D + H D + H + 0.75 (L _r or S) + 0.75L ²	1.2D + 1.6H 1.2D + 1.6H + 1.6L ² + 0.5(L _r + S) 1.2D + 1.6H + 1.6(L _r or S) + L ²
Headers, girders, joists, interior load-bearing walls and columns, footings (gravity loads)	D + 0.75 L ² + 0.75 (L _r or S) D + 0.75 (L _r or S) + 0.75 L ²	1.2D + 1.6L ² + 0.5 (L _r or S) 1.2D + 1.6(L _r or S) + L ²
Exterior load-bearing walls and columns (gravity and transverse lateral load) ³	Same as immediately above, plus 0.6D + 0.6W D + 0.7E + 0.75L ² + 0.75S ⁴	Same as immediately above, plus 1.2D + 1.0W 1.2D + 1.0E + L ² + 0.2S ⁴
Roof rafters, trusses, and beams; roof and wall sheathing (gravity and wind loads)	D + (L _r or S) 0.6D + 0.6W _u ⁵ 0.6D + 0.6W	1.2D + 1.6(L _r or S) 0.9D + 1.0W _u ⁵ 1.2D + 1.0W
Floor diaphragms and shear walls (in-plane lateral and overturning loads) ⁶	0.6D + (0.6W or 0.7E)	0.9D + (1.0W or 1.0E)

Notes:

¹The load combinations and factors are intended to apply to nominal design loads defined as follows: D = estimated mean dead weight of the construction; E = design earthquake load; H = design lateral pressure for soil condition/type; L = design floor live load; L_r = maximum roof live load anticipated from construction/maintenance;; S = design roof snow load; and W = design wind load. The design or nominal loads should be determined in accordance with this chapter.

²Attic loads may be included in the floor live load, but a 10-psf attic load typically is used only to size ceiling joists adequately for access purposes. If the attic is intended for storage, however, the attic live load (or some portion) should also be considered for the design of other elements in the load path.

³The transverse wind load for stud design is based on a localized component and cladding wind pressure; D + W provides an adequate and simple design check representative of worst-case combined axial and transverse loading. Axial forces from snow loads and roof live loads should usually not be considered simultaneously with an extreme wind load because they are mutually exclusive on residential sloped roofs. Further, in most areas of the United States, design winds are produced by either hurricanes or thunderstorms; therefore, these wind events and snow are mutually exclusive because they occur at different times of the year.

⁴For walls supporting heavy cladding loads (such as brick veneer), an analysis of earthquake lateral loads and combined axial loads should be considered; however, this load combination rarely governs the design of light-frame construction.

⁵W_u is wind uplift load from negative (that is, suction) pressures on the roof. Wind uplift loads must be resisted by continuous load path connections to the foundation or until offset by D.

⁶The 0.6 reduction factor on D is intended to apply to the calculation of net overturning stresses and forces. For wind, the analysis of overturning should also consider roof uplift forces unless a separate load path is designed to transfer those forces.

3.3 Dead Loads

Dead loads consist of the permanent construction material loads comprising the roof, floor, wall, and foundation systems, including claddings, finishes, and fixed equipment. The values for dead loads in table 3.2 are for commonly used materials and constructions in light-frame residential buildings. Dead loads are given as nominal or ASD-level loads. Table 3.3 provides values for common material densities and may be useful in calculating dead loads more accurately. The design examples in section 3.12 demonstrate the straightforward process of calculating dead loads.

TABLE 3.2

Dead Loads for Common Residential Construction¹

<p>Roof Construction Light-frame wood roof with wood structural panel sheathing and 1/2-inch gypsum board ceiling (2 psf) with asphalt shingle roofing (3 psf)</p> <ul style="list-style-type: none"> - with conventional clay/tile roofing - with lightweight tile - with metal roofing - with wood shakes - with tar and gravel 	<p>15 psf</p> <p>27 psf</p> <p>21 psf</p> <p>14 psf</p> <p>15 psf</p> <p>18 psf</p>																																				
<p>Floor Construction Light-frame 2x12 wood floor with 3/4-inch wood structural panel sheathing and 1/2-inch gypsum board ceiling (without 1/2-inch gypsum board, subtract 2 psf from all values) with carpet, vinyl, or similar floor covering</p> <ul style="list-style-type: none"> - with wood flooring - with ceramic tile - with slate 	<p>10 psf²</p> <p>12 psf</p> <p>15 psf</p> <p>19 psf</p>																																				
<p>Wall Construction Light-frame 2x4 wood wall with 1/2-inch wood structural panel sheathing and 1/2-inch gypsum board finish (for 2x6, add 1 psf to all values)</p> <ul style="list-style-type: none"> - with vinyl or aluminum siding - with lap wood siding - with 7/8-inch portland cement stucco siding - with thin-coat stucco on insulation board - with 3-1/2-inch brick veneer <p>Interior partition walls (2x4 with 1/2-inch gypsum board applied to both sides)</p>	<p>6 psf</p> <p>7 psf</p> <p>8 psf</p> <p>15 psf</p> <p>9 psf</p> <p>45 psf</p> <p>6 psf</p>																																				
<p>Foundation Construction</p> <p>6-inch-thick wall</p> <p>8-inch-thick wall</p> <p>10-inch-thick wall</p> <p>12-inch-thick wall</p> <p>6-inch x 12-inch concrete footing</p> <p>6-inch x 16-inch concrete footing</p> <p>8-inch x 24-inch concrete footing</p>	<table border="0"> <thead> <tr> <th></th> <th colspan="2">Masonry³</th> <th>Concrete</th> </tr> <tr> <th></th> <th>Hollow</th> <th>Solid or Full Grout</th> <th></th> </tr> </thead> <tbody> <tr> <td></td> <td>28 psf</td> <td>60 psf</td> <td>75 psf</td> </tr> <tr> <td></td> <td>36 psf</td> <td>80 psf</td> <td>100 psf</td> </tr> <tr> <td></td> <td>44 psf</td> <td>100 psf</td> <td>123 psf</td> </tr> <tr> <td></td> <td>50 psf</td> <td>125 psf</td> <td>145 psf</td> </tr> <tr> <td></td> <td></td> <td></td> <td>73 plf</td> </tr> <tr> <td></td> <td></td> <td></td> <td>97 plf</td> </tr> <tr> <td></td> <td></td> <td></td> <td>193 plf</td> </tr> </tbody> </table>		Masonry ³		Concrete		Hollow	Solid or Full Grout			28 psf	60 psf	75 psf		36 psf	80 psf	100 psf		44 psf	100 psf	123 psf		50 psf	125 psf	145 psf				73 plf				97 plf				193 plf
	Masonry ³		Concrete																																		
	Hollow	Solid or Full Grout																																			
	28 psf	60 psf	75 psf																																		
	36 psf	80 psf	100 psf																																		
	44 psf	100 psf	123 psf																																		
	50 psf	125 psf	145 psf																																		
			73 plf																																		
			97 plf																																		
			193 plf																																		

psf = pounds per square foot

Notes:

¹For unit conversions, see appendix B.

²Value also used for roof rafter construction (that is, cathedral ceiling).

³For partially grouted masonry, interpolate between hollow and solid grout in accordance with the fraction of masonry cores that are grouted.

TABLE 3.3**Densities for Common Residential Construction Materials¹**

Aluminum	170 pcf
Copper	556 pcf
Steel	492 pcf
Concrete (normal weight with light reinforcement)	145–150 pcf
Masonry, grout	140 pcf
Masonry, brick	100–130 pcf
Masonry, concrete	85–135 pcf
Glass	160 pcf
Wood (approximately 10 percent moisture content) ²	
- spruce-pine-fir (G = 0.42)	29 pcf
- spruce-pine-fir, south (G = 0.36)	25 pcf
- southern yellow pine (G = 0.55)	38 pcf
- Douglas fir-larch (G = 0.5)	34 pcf
- hem-fir (G = 0.43)	30 pcf
- mixed oak (G = 0.68)	47 pcf
Water	62.4 pcf
Structural wood panels	
- plywood	36 pcf
- oriented strand board	36 pcf
Gypsum board	50 pcf
Stone	
- Granite	96 pcf
- Sandstone	82 pcf
Sand, dry	90 pcf
Gravel, dry	104 pcf

pcf = pounds per cubic foot

Notes:

¹For unit conversions, see appendix B.

²The equilibrium moisture content of lumber is usually not more than 10 percent in protected building construction. The specific gravity, G, is the decimal fraction of dry wood density relative to that of water; therefore, at a 10 percent moisture content, the density of wood is 1.1(G)(62.4 lbs/ft³). The values given are representative of average densities and may easily vary by as much as 15 percent, depending on lumber grade and other factors.

3.4 Live Loads

Live loads are produced by the use and occupancy of a building. Loads include those from human occupants, furnishings, nonfixed equipment, storage, and construction and maintenance activities. Table 3.4 provides recommended design live loads for residential buildings. Live loads also are given as nominal or ASD-level loads. Example 3.1 in section 3.10 demonstrates use of those loads and the load combinations specified in table 3.1, along

with other factors discussed in this section. As required to adequately define the loading condition, loads are presented in terms of uniform area loads (in pounds per square foot: psf), concentrated loads (in pounds: lbs), and uniform line loads (in pounds per linear foot: plf). The uniform and concentrated live loads should not be applied simultaneously in a structural evaluation. Concentrated loads should be applied to a small area or surface consistent with the application and should be located or directed to give the maximum load effect possible in end-use conditions. For example, the stair concentrated load of 300 pounds should be applied to the center of the stair tread between supports. The concentrated wheel load of a vehicle on a garage slab or floor should be applied to all areas or members subject to a wheel or jack load, typically using a loaded area of about 20 square inches.

TABLE 3.4 **Live Loads for Residential Construction¹**

Application	Uniform Load	Concentrated Load
Roof ²		
Slope \geq 4:12	15 psf	250 lbs
Flat to 4:12 slope	20 psf	250 lbs
Attic ³		
Without storage	10 psf	250 lbs
With storage	20 psf	250 lbs
Floors		
Bedroom areas ^{3,4}	30 psf	300 lbs
Other areas	40 psf	300 lbs
Garages	50 psf	2,000 lbs (passenger cars, vans, light trucks)
Decks and balconies	40 psf ⁷	
Stairs	40 psf	300 lbs
Guards and handrails	50 plf ⁵	200 lbs
Guard in-fill components	50 psf ⁶	
Grab bars	N/A	250 lbs

lbs = pounds; plf = pounds per linear foot; psf = pounds per square foot

Notes:

- ¹Live load values should be verified relative to the locally applicable building code.
- ²Roof live loads are intended to provide a minimum load for roof design in consideration of maintenance and construction activities. They should not be considered in combination with other transient loads (for example, floor live load, wind load) when designing walls, floors, and foundations. A 15-psf roof live load is recommended for residential roof slopes greater than 4:12; refer to ASCE 7-10 for an alternate approach.
- ³Loft sleeping and attic storage loads should be considered only in areas with a clear height greater than about 3.5 feet. The concept of a “clear height” limitation on live loads is logical, but it may not be universally recognized.
- ⁴Some codes require 40 psf for all floor areas.
- ⁵ASCE 7-10 indicates that this load does not have to be considered for one- and two-family dwellings.
- ⁶The applied normal load on an area is not to exceed 12 in. by 12 in.
- ⁷ASCE 7 requirements may be more stringent.

The floor live load on any given floor area may be reduced in accordance with equation 3.4-1 (Harris, Corotis, and Bova, 1981). Live load reductions also are allowed for multiple floors in ASCE 7-10. The equation applies to floor and support members, such as beams or columns (see table 3-5), which experience floor loads from a total tributary floor area greater than 200 square feet. This equation also is in chapter 4 of ASCE 7-10, which covers live load design.

Equation 3.4-1

$$L = L_o \left[0.25 + \frac{15}{\sqrt{K_{LL} A_T}} \right]$$

where

- L = reduced design live load per ft² of area supported by the member
- K_{LL} = live load element factor
- L_o = unreduced design live load per ft² of area supported by the member
- A_T = the tributary area in ft²

L shall not be less than 0.50L_o for members supporting one floor and not less than 0.40L_o for members supporting two or more floors.

TABLE 3.5 *Live Load Element Factor, K_{LL}*

Element	K _{LL} *
Interior columns	4
Exterior columns without cantilever slabs	4
Edge columns with cantilever slabs	3
Corner columns with cantilever slabs	2
Edge beams without cantilever slabs	2
Interior beams	2
All other members not identified, including	1
Edge beams with cantilever slabs	
Cantilever beams	
One-way slabs	
Two-way slabs	
Members without provisions for continuous shear transfer normal to their span	
*In lieu of the preceding values, K _{LL} may be calculated.	

Note also that the nominal design floor live load in table 3.4 includes both a sustained and a transient load component. The sustained component is that load typically present at any given time and includes the load associated with normal human occupancy and furnishings. For residential buildings, the mean sustained live load is about 6 psf but typically varies from 4 to 8 psf (Chalk and Corotis, 1978). The mean transient live load for dwellings also is about 6 psf but may be as high as 13 psf. A total design live load of 30 to 40 psf is therefore fairly conservative.

3.5 Soil Lateral Loads

The lateral pressure exerted by earth backfill against a residential foundation wall (basement wall) can be calculated with reasonable accuracy on the basis of theory, but only for conditions that rarely occur in practice (Peck, Hanson, and Thornburn, 1974; University of Alberta, 1992). Theoretical analyses usually are based on homogeneous materials that demonstrate consistent compaction and behavioral properties. Such conditions rarely are experienced in typical residential construction projects.

The most common method of determining lateral soil loads on residential foundations follows Rankine's (1857) theory of earth pressure and uses what is known as the Equivalent Fluid Density (EFD) method. As shown in figure 3.1, pressure distribution is assumed to be triangular and to increase with depth.

In the EFD method, the soil unit weight w is multiplied by an empirical coefficient K_a to account for the soil is not actually fluid and the pressure distribution is not necessarily triangular. The coefficient K_a is known as the active Rankine pressure coefficient. The EFD is determined as shown in equation 3.5-1.

Equation 3.5-1
$$q = K_a w$$

FIGURE 3.1 *Triangular Pressure Distribution on a Basement Foundation Wall*

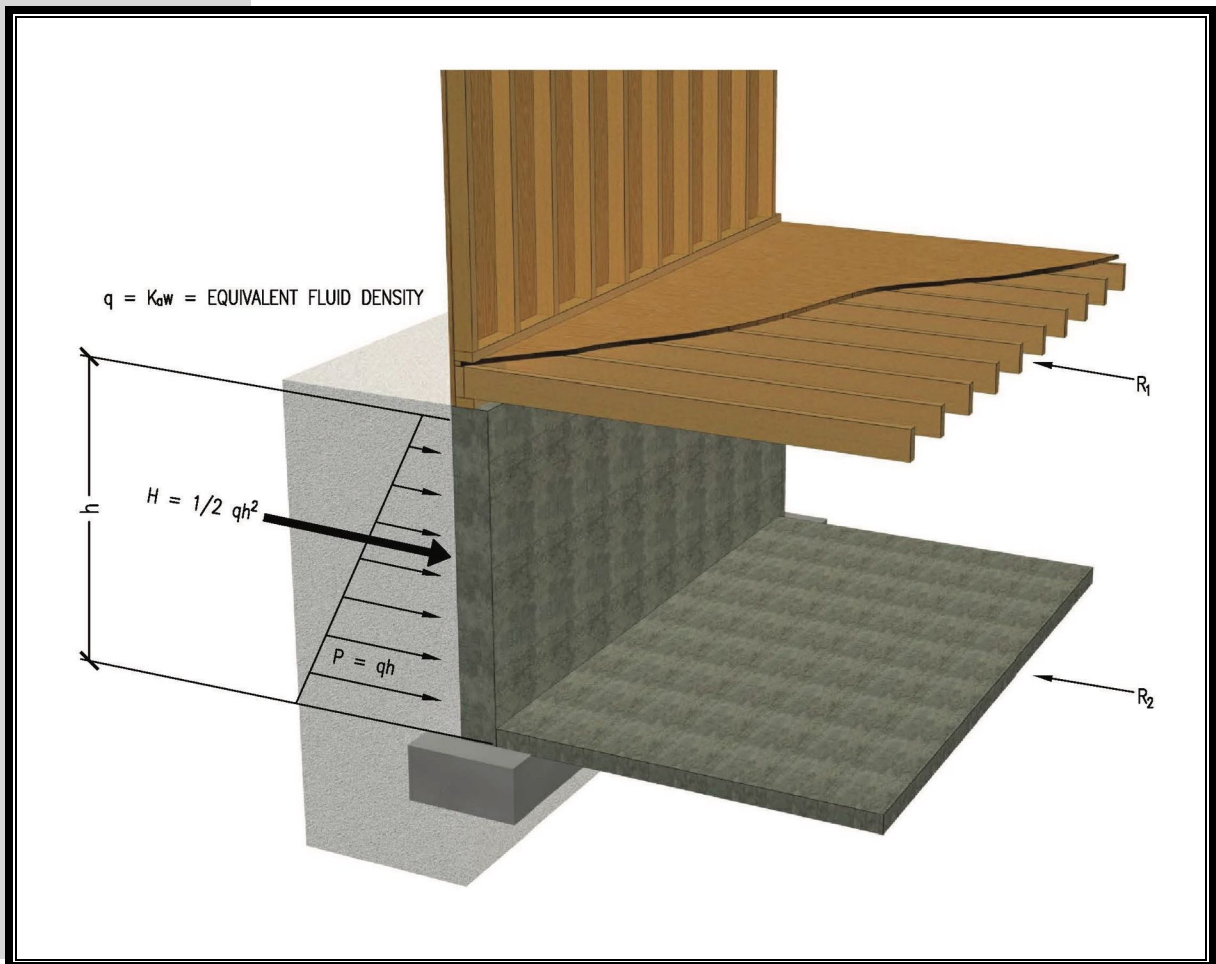

For the triangular pressure distribution shown in figure 3.1, the pressure, P in psf, at depth, h in feet, is determined by equation 3.5-2, and the resultant force, H in lbs, at depth, h in feet, is determined by equation 3.5-3. The factor q is the EFD as discussed above.

$$P = qh$$

Equation 3.5-2

The total active soil force (pounds per linear foot of wall length) is—

Equation 3.5-3

$$H = \frac{1}{2}(qh)(h) = \frac{1}{2}qh^2$$

where h = the depth of the unbalanced fill on a foundation wall
 H = the resultant force (plf) applied at a height of h/3 from the base of the unbalanced fill because the pressure distribution is assumed to be triangular

The EFD method is subject to judgment as to the appropriate value of the coefficient K_a . The values of K_a in table 3.6 are recommended for the determination of lateral pressures on residential foundations for various types of backfill materials placed with light compaction and good drainage. Given the long-time use of a 30 pounds per cubic foot (pcf) EFD in residential foundation wall prescriptive design tables (ICC, 2012), the values in table 3.6 may be considered somewhat conservative for typical conditions. A relatively conservative safety factor of 3 to 4 is typically applied to the design of unreinforced or nominally reinforced masonry or concrete foundation walls (ACI, 2011). Therefore, at imminent failure of a foundation wall, the 30 psf design EFD would correspond to an active soil lateral pressure determined by using an EFD of about 90 to 120 pcf or more. The design examples in chapter 4 demonstrate the calculation of soil loads.

TABLE 3.6 *Values of K_a , Soil Unit Weight, and Equivalent Fluid Density by Soil Type^{1,2,3}*

Type of Soil ⁴ (Unified Soil Classification)	Active Pressure Coefficient (K_a)	Soil Unit Weight (pcf)	Equivalent Fluid Density (pcf)
Sand or gravel (GW, GP, GM, SW, SP)	0.26	115	30
Silty sand, silt, and sandy silt (GC, SM)	0.35	100	35
Clay-silt, silty clay (SM-SC, SC, ML, ML-CL)	0.45	100	45
Clay ⁵ (CL, MH, CH)	0.60	100	60

Notes:

¹ Values are applicable to well-drained foundations with less than 10 feet of backfill placed with light compaction or natural settlement, as is common in residential construction. The values do not apply to foundation walls in flood-prone environments; in such cases, an equivalent fluid density value of 80 to 90 pcf would be more appropriate (HUD, 1977).

² Values are based on the *Standard Handbook for Civil Engineers*, 3rd ed. (Merritt, 1983), and on research on soil pressures reported in *Thin Wall Foundation Testing*, Department of Civil Engineering, University of Alberta, (March 1992). The designer should note that the values for soil equivalent fluid density differ from those recommended in ASCE 7-10 but are nonetheless compatible with current residential building codes, design practice, and the stated references.

³ These values do not consider the significantly higher loads that can result from expansive clays and the lateral expansion of moist, frozen soil. Such conditions should be avoided by eliminating expansive clays adjacent to the foundation wall and providing for adequate surface and foundation drainage.

⁴ Organic silts and clays and expansive clays are unsuitable for backfill material.

⁵ Backfill in the form of clay soils (non-expansive) should be used with caution on foundation walls with unbalanced fill heights greater than 3 to 4 feet and on cantilevered foundation walls with unbalanced fill heights greater than 2 to 3 feet.

Depending on the type and depth of backfill material and the manner of its placement (see table 3.7), common practice in residential construction is to allow the backfill soil to consolidate naturally by providing an additional 3 to 6 inches of fill material. The additional backfill ensures that surface water drainage away from the foundation remains adequate (that is, the grade slopes away from the building). It also helps avoid heavy compaction that could cause undesirable loads on the foundation wall during and after construction. If soils are heavily compacted at the ground surface or compacted in lifts to standard Proctor densities greater than approximately 85 percent of optimum (ASTM, 2012), the standard 30 pcf EFD assumption may be inadequate. In cases in which the backfill supports exterior slabs, patios, stairs, or other items, however, some amount of compaction is required unless the structures are supported on a separate foundation bearing on undisturbed ground.

Some remediation may be necessary in areas that contain marine clay or other expansive soils. In very moist conditions, these soils can place significant lateral loads against foundation walls. The soils may need to be replaced with soil of lower clay content or the moisture levels must be stabilized to reduce excessive lateral pressures.

TABLE 3.7 *Lateral Soil Load*

Description of Backfill Material ³	Unified Soil Classification	Design Lateral Soil Load ¹ (pound per square foot per foot of depth)	
		Active Pressure	At-Rest Pressure
Well-graded, clean gravels; gravel-sand mixes	GW	30	60
Poorly graded clean gravels; gravel-sand mixes	GP	30	60
Silty gravels; poorly graded gravel-sand mixes	GM	40	60
Clayey gravels; poorly graded gravel-clay mixes	GC	45	60
Well-graded, clean sands; gravelly sand mixes	SW	30	60
Poorly graded clean sands; sand-gravel mixes	SP	30	60
Silty sands; poorly graded sand-silt mixes	SM	45	60
Sand-silt clay mix with plastic fines	SM-SC	45	100
Clayey sands; poorly graded sand-clay mixes	SC	60	100
Inorganic silts; clayey silts	ML	45	100
Inorganic silt-clay mixes	ML-CL	60	100
Inorganic clays of low to medium plasticity	CL	60	100
Organic silts and silt clays of low plasticity	OL	2	2
Inorganic clayey silts; elastic silts	MH	2	2
Inorganic clays of high plasticity	CH	2	2

Notes:

¹ Design lateral soil loads are given for moist conditions for the specified soils at their optimum densities. Actual field conditions shall govern.

² Unsuitable as backfill material

³ The definition and classification of soil materials is in accordance with ASTM D2487.

3.6 Wind Loads

3.6.1 General

Wind produces dynamic loads on a structure at highly variable magnitudes. The variation in pressures at different locations on a building is complex to the point that pressures may become too analytically intensive for precise consideration in design. Wind load specifications attempt to simplify the design problem by considering basic static pressure zones on a building representative of peak loads that are likely to be experienced. The peak pressures in one zone for a given wind direction may not, however, occur simultaneously with peak pressures in other zones. For some pressure zones, the peak pressure depends on a narrow range of wind directions; therefore, the wind directionality effect must also be factored into determining risk-consistent wind loads on buildings. Characteristics of the building site and the surrounding area, such as exposure and topography, also play a large role in determining the peak pressures on the structure and should be carefully considered. In fact, most modern wind load specifications account for wind directionality and other effects in determining nominal design loads in some simplified form (ASCE, 2010). This section further simplifies wind load design specifications to provide an easy yet effective approach for designing typical residential buildings.

Because they vary substantially over the surface of a building, wind loads are considered at two different scales. On a large scale, the loads produced on the overall building are resisted by a system of structural elements working together to transfer the wind loads acting on the entire structure to the ground, a system known as the main wind force-resisting system (MWFRS). The MWFRS of a home includes the shear walls and diaphragms that create the lateral force-resisting system (LFRS) as well as the structural systems, such as trusses, that experience loads from external and internal pressures generated on the building. The wind loads applied to the MWFRS account for the area-averaging effects of time-varying wind pressures on the surface or surfaces of the building.

Wind pressures are greater on certain localized surface areas of the building, particularly near abrupt changes in building geometry (for example, eaves, ridges, and corners). Those higher wind pressures can occur on smaller areas, particularly affecting the loads carried by components and cladding (for example, sheathing, windows, doors, purlins, and studs). The components and cladding (C&C) transfer localized time-varying loads to the MWFRS, at which point the loads average out both spatially and temporally since, at a given time, some components may be at near peak loads while others are at substantially less than peak.

In light-framed wood structural systems, the distinction between MWFRS and C&C is not as clear-cut as in other buildings. In some cases, structural components may act as MWFRS and as C&C, depending on situations. The designer must consider which elements of the building must be treated as C&C, part of the MWFRS, or both. As indicated, parts of the MWFRS that collect and transfer lateral loads in shear walls and floors or roof diaphragms consist of wall studs, sheathing,

and trusses, and these elements as a system must be designed for MWFRS lateral loads; but the studs, sheathing, and truss chords must be designed for the direct loading from wind as C&C. Thus, the stud size and connection to top and bottom plates must be designed for C&C pressures, yet the entire wall system, especially the sheathing thickness and the nailing attachment of the sheathing to the studs, must be designed to resist the shear forces created by the lateral loads.

The next section presents a simplified method for determining both MWFRS and C&C wind loads. Because the loads in section 3.6.2 are determined for specific applications, the calculation of MWFRS and C&C wind loads is implicit in the values provided. Design example 3.2 in section 3.12 demonstrates the calculation of wind loads by applying the simplified method in the following section to several design conditions associated with wind loads and the load combinations presented in table 3.1.

3.6.2 Determination of Wind Loads on Residential Buildings

The following method for the design of residential buildings is based on a simplification of the ASCE 7-10 wind provisions (ASCE, 2010); therefore, the wind loads are not exact duplicates. Lateral loads and roof uplift loads are determined by using a projected area approach. Other wind loads are determined for specific components or assemblies that comprise the exterior building envelope. Determining design wind loads on a residential building and its components requires five steps.

Step 1: Determine site design wind speed and basic velocity pressure

From the wind map in figure 3.2 (refer to ASCE 7-10 for a more detailed map for risk category II buildings), select a design wind speed for the site (ASCE, 2010), or, alternatively, find a location-specific wind speed from the local building code office or by using www.atcouncil.org/windspeed. The wind speed map in ASCE 7-10 (figure 3.2) includes the most accurate data and analysis available regarding design wind speeds in the United States. The ASCE 7-10 wind speeds are higher than those used in older design wind maps. The difference results solely from using ultimate wind speeds developed for use with 700-year return periods for risk category II buildings that include residential uses. The speeds correspond to approximately a 7 percent probability of exceedance in 50 years. The design 3-second peak gust wind speeds are 110 to 115 miles per hour (mph) in most of the United States; however, along the hurricane-prone Gulf and Atlantic coasts, the design wind speeds range from 115 to 180 mph. The wind speeds are standardized for exposure C conditions at 33 feet (10 meters). Tornadoes have not been considered in the design wind speeds presented in figure 3.2. Design loads for tornadoes are still in the development stage, and discussion of the latest knowledge is provided in section 3.10.

Once the nominal design wind speed in terms of peak 3-second gust is determined, the designer can select the basic velocity pressure, in accordance with table 3.8. The basic velocity pressure is a reference wind pressure to which coefficients are applied to determine the surface pressures on a building. Velocity pressures in table 3.8 are based on typical conditions for residential construction,

namely, suburban terrain (exposure B) and relatively flat or rolling terrain without topographic wind speed-up effects.

FIGURE 3.2a *Basic Design Wind Speed Map from ASCE 7-10*

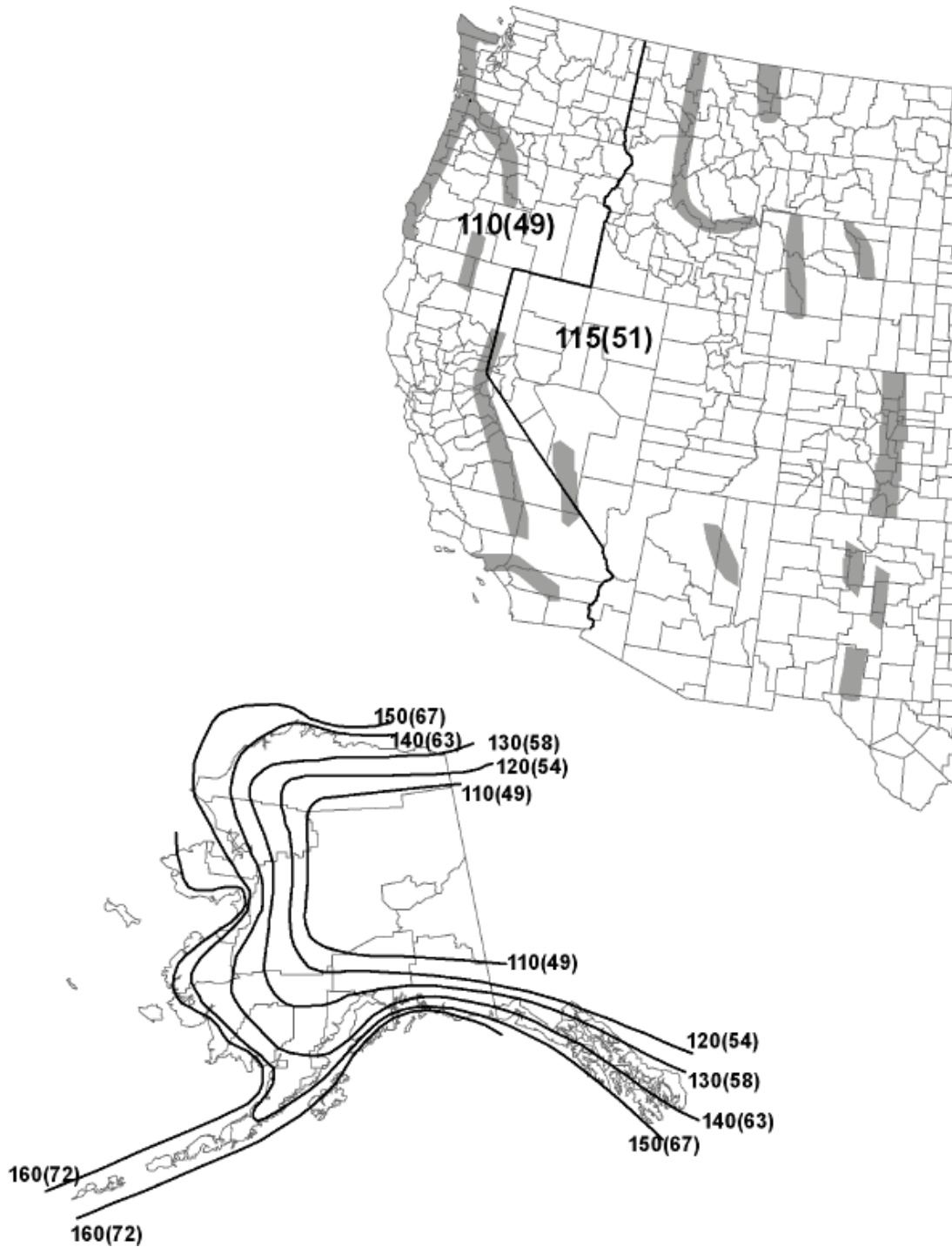

Source: Reprinted with permission from the American Society of Civil Engineers, 1801 Alexander Bell Road, Reston, VA. Copyright ASCE.

FIGURE 3.2b Basic Design Wind Speed Map from ASCE 7-10

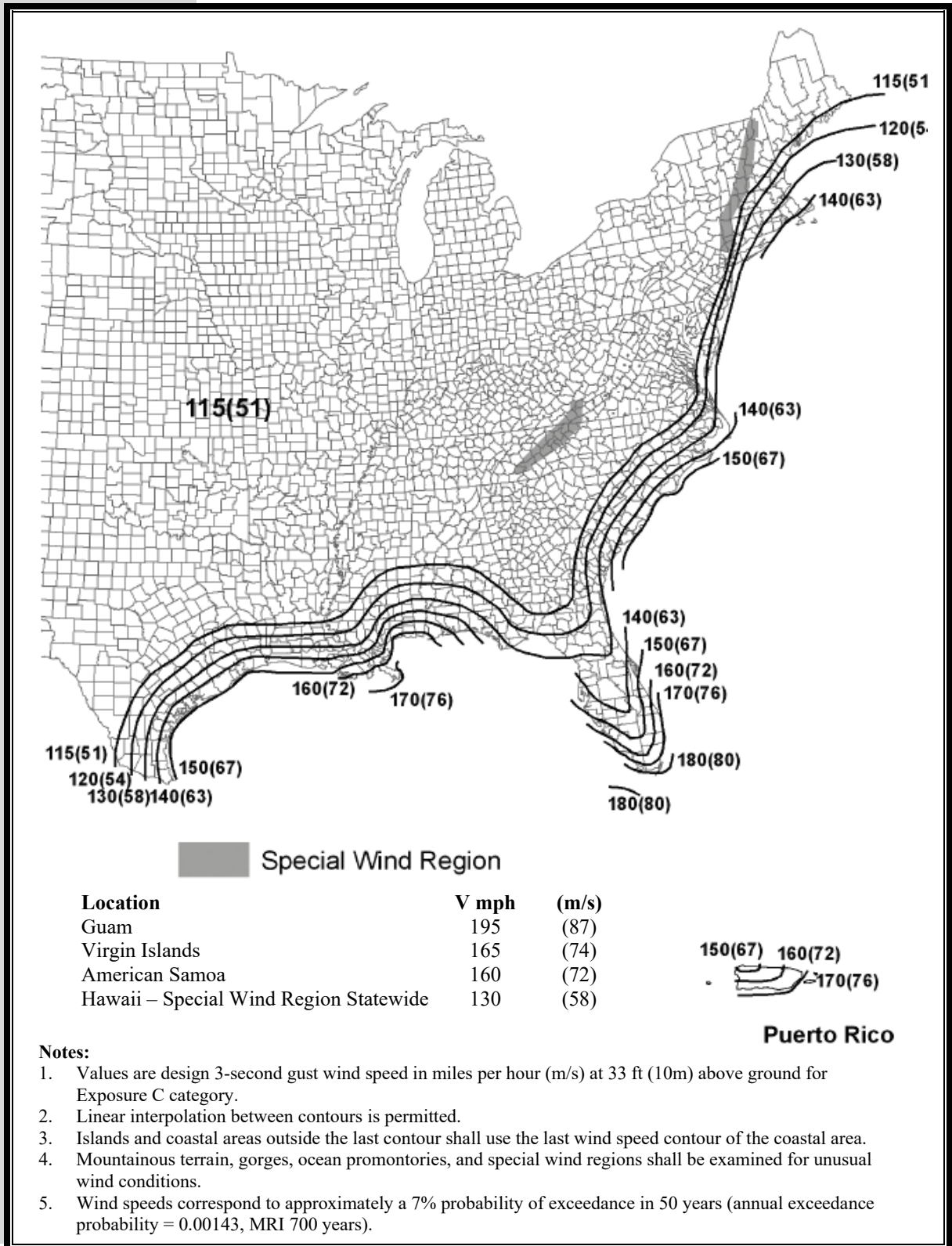

Source: Reprinted with permission from the American Society of Civil Engineers, 1801 Alexander Bell Road, Reston, VA. Copyright ASCE.

TABLE 3.8**Basic Wind Velocity Pressures (psf) for Suburban Terrain¹ (MWFRS)**

Design Wind Speed, V (mph, peak gust)	One-Story Building (15') ($K_z = 0.57$) ²	Two-Story Building (30') ($K_z = 0.7$) ²	Three-Story Building (45') ($K_z = 0.78$)
110	15	18	21
115	16	20	22
120	18	22	24
130	21	26	29
140	24	30	33
150	28	34	38
160	32	39	43
170	36	44	49
180	40	49	55

mph = miles per hour; MWFRS = main wind force-resisting system; psf = pounds per square foot.

Notes:

¹Velocity pressure (psf) equals $0.00256 K_D K_z V^2$, where K_z is the velocity pressure exposure coefficient associated with the vertical wind speed profile in suburban terrain (exposure B) at the mean roof height of the building. K_D is the wind directionality factor, with a default value of 0.85. All pressures have been rounded to nearest whole psf.

²To be compliant with ASCE 7-10, a minimum K_z of 0.7 should be applied to determine velocity pressure for one- and two-story buildings in exposure B (suburban terrain) for the design of components and cladding, in exposure B when the envelope procedure is used for the MWFRS, or when designing components and cladding.

Step 2: Adjustments to the basic velocity pressure

If appropriate, the basic velocity pressure from step 1 should be adjusted in accordance with the factors below. The adjustments are cumulative.

Open exposure. The wind pressure values in table 3.8 are based on typical residential exposures to wind (exposure B). If a site is located in generally open, flat terrain with few obstructions to the wind in most directions (exposure C), the designer should multiply the values in table 3.8 by a factor of 1.4. Exposure to a body of water (that is, an ocean or lake) increases wind pressures more because of reduced friction at the surface (exposure D). The values in table 3.8 should be multiplied by a factor of 1.7 to account for this increased pressure for exposure D conditions. The factor may be used to adjust wind loads according to the exposure related to the specific directions of wind approach to the building. The wind exposure conditions used in this guide are derived from ASCE 7-10, and more information about how to determine these exposures is provided in the ASCE 7-10 commentary.

Wind directionality. As noted, the direction of the wind in a given event does not create peak loads (which provide the basis for design pressure coefficients) simultaneously on all building surfaces. In some cases, the pressure zones with the highest design pressures are extremely sensitive to wind direction. In accordance with ASCE 7-10, the velocity pressures in table 3.8 are based on a directionality adjustment of 0.85.

Topographic effects. If topographic wind speed-up effects are likely because a structure is located near the crest of a protruding hill or cliff, the designer should consider using the topographic factor provided in ASCE 7-10. Wind loads can be increased for buildings sited in particularly vulnerable locations relative to topographic features that cause localized wind speed-up for specific wind directions.

The *International Residential Code* (IRC; ICC 2011) provides a “Simplified Topographic Wind Speed-up Method” for the K_{zt} factor where required. The simplified method in the IRC is based on the wind speed-up effect for cliff edges, the most vulnerable of the three types of features (hills, ridges or escarpments), and on certain terrain feature heights and dwelling locations. If a more accurate and potentially less conservative determination of an adjusted design wind speed is desired, the designer can apply the ASCE 7-10 provisions for adjusting the wind speed to account for the K_{zt} factor, where required.

Step 3: Determine lateral wind pressure coefficients

Lateral pressure coefficients in table 3.9 are composite pressure coefficients that combine the effect of positive pressures on the windward face of the building and negative (suction) pressures on the leeward faces of the building. The lateral pressure coefficients are the total effect of the shape factor (C_p) and the gust effect factor (G). When multiplied by the velocity pressure from steps 1 and 2, the selected pressure coefficient provides a single wind pressure that is applied to the vertical projected area of the roof and wall, as indicated in table 3.9. The resulting load is then used to design the home’s LFRS (see chapter 6). The lateral wind load must be determined for the two orthogonal directions on the building (that is, parallel to the ridge and perpendicular to the ridge), using the vertical projected area of the building for each direction. Lateral loads are then assigned to various systems (for example, shear walls, floor diaphragms, and roof diaphragms) by use of tributary areas or other methods described in chapter 6.

This method can be used for determining shear loads because the internal pressures in the building cancel out and do not affect the shear loads. Overturning moments and the design of wall studs and lateral out-of-plane wall loads at the roof-to-wall connection must consider the effects of internal pressure, however; thus, the projected area method is not useful for those calculations. See step 4 for additional information.

TABLE 3.9 *Lateral Pressure Coefficients for Application to Vertical Projected Areas*

Application	Lateral Pressure Coefficients
Roof Vertical Projected Area (by slope)	
Flat	0.0
3:12	0.43
6:12	0.77
≥9:12	0.85
Wall Projected Area	1.1

Step 4: Determine wind pressure coefficients for components and assemblies

The pressure coefficients in table 3.9 are derived from ASCE 7-10, based on the assumption that the building is enclosed and not subject to higher internal pressures that may result from a windward opening in the building. Using the values in table 3.9 greatly simplifies the more detailed methodology described in ASCE 7-10; as a result, some numbers are “rounded.” With the exception of the roof uplift coefficient, all pressures calculated with the coefficients are intended to be applied perpendicular to the building surface area that is tributary to the element of concern; thus, the wind load is applied perpendicular to the actual building surface, not to a projected area. The roof uplift pressure coefficient is used to determine a single wind pressure that may be applied to a horizontal projected area of the roof to determine roof tie-down connection forces.

For buildings in hurricane-prone regions subject to wind-borne debris, the GC_p values in table 3.10 are still valid, but the glazed openings in the building must be protected from the possibility of damage by wind-borne debris breaching a wall or roof opening, such as a window or skylight. Past versions of ASCE 7 had allowed design for a “partially enclosed” condition using higher internal pressure coefficients in wind-borne debris regions, but this technique allows a potentially significant amount of wind-driven rain into the building, which would still create a near total economic loss. ASCE 7 no longer allows this design method.

Step 5: Determine design wind pressures

Once the basic velocity pressure is determined in step 1 and adjusted in step 2 for exposure and other site-specific considerations, the designer can calculate the design wind pressures by multiplying the adjusted basic velocity pressure by the pressure coefficients selected in steps 3 and 4. The lateral pressures on the MWFRS are based on coefficients from step 3 and are applied to the tributary areas of the LFRS, such as shear walls and diaphragms. The pressures based on coefficients from step 4 are applied to tributary areas of members such as studs, rafters, trusses, and sheathing to determine stresses in members and forces in connections.

TABLE 3.10**Wind Pressure Coefficients for Systems and Components
(enclosed building)¹**

Application	Pressure Coefficients (GC _p) ²
Roof	
Trusses, roof beams, ridge and hip/valley rafters	-0.9, +0.4
Rafters and truss panel members	-1.2, +0.7
Roof sheathing	-2.8, +0.7
Skylights and glazing	-1.2, +1.0
Roof uplift ³	
- hip roof with slope between 3:12 and 6:12	-0.9
- hip roof with slope greater than 6:12	-0.8
- all other roof types and slopes	-1.2
Windward overhang ⁴	+ 0.7
Wall	
All framing members	-1.5, +1.1
Wall sheathing and cladding/siding	-1.6, +1.2
Windows, doors, and glazing	-1.3, +1.2
Garage doors	-1.1, +1.0
Air-permeable claddings ⁵	-0.9, 0.8

Notes:

¹All coefficients include internal pressure in accordance with the assumption of an enclosed building. With the exception of the categories labeled trusses, roof beams, ridge and hip/valley rafters, and roof uplift, which are based on MWFRS loads, all coefficients are based on component and cladding wind loads.

²Positive and negative signs represent pressures acting inwardly and outwardly, respectively, from the building surface. A negative pressure is a suction or vacuum. Both pressure conditions should be considered to determine the controlling design criteria.

³The roof uplift pressure coefficient is used to determine uplift pressures that are applied to the horizontal projected area of the roof for the purpose of determining uplift tie-down forces. Additional uplift force on roof tie-downs resulting from roof overhangs should also be included. The uplift force must be transferred to the foundation or to a point where it is adequately resisted by the dead load of the building and the capacity of conventional framing connections.

⁴The windward overhang pressure coefficient is applied to the underside of a windward roof overhang and acts upwardly on the bottom surface of the roof overhang. If the bottom surface of the roof overhang is the roof sheathing, or if the soffit is not covered with a structural material on its underside, then the overhang pressure shall be considered additive to the roof sheathing pressure.

⁵Air-permeable claddings allow for pressure relief such that the cladding experiences about two-thirds of the pressure differential experienced across the wall assembly (FPL, 1999). Products that experience reduced pressure include lap-type sidings such as wood, vinyl, aluminum, and other similar sidings. Since these components are usually considered “nonessential,” it may be practical to multiply the calculated wind load on any nonstructural cladding by 0.75 to adjust for a serviceability wind load (Galambos and Ellingwood, 1986). Such an adjustment would also be applicable to deflection checks, if required, for other components listed in the table. However, a serviceability load criterion is not included or clearly defined in existing design codes.

3.6.3 Special Considerations in Hurricane-Prone Environments

3.6.3.1 Wind-Borne Debris

The wind loads determined in the previous section assume an enclosed building. If glazing in windows and doors is not protected from wind-borne debris or otherwise designed to resist potential impacts during a major hurricane, a building is more susceptible to structural damage resulting from higher internal pressures that

may develop with a windward opening. The potential for water damage to building contents also increases. Openings created in the building envelope during a major hurricane or tornado often are related to unprotected glazing, improperly fastened sheathing, or weak garage doors and their attachment to the building. Section 3.10 discusses tornado design conditions.

In recent years, much attention has been focused on wind-borne debris, based on the results of many damage investigations. Little research has been done to quantify the magnitude or type of debris. The current wind-borne debris protection trigger is wind speed, and the requirement for wind-borne debris protection is all or nothing—meaning that, in accordance with ASCE 7-10, protection must be provided where design wind speeds are 130 mph and the building is within one mile of the coastal mean high-water line, or anywhere the design wind speed is 140 mph or greater. Conventional practice for wind-borne debris protection in residential construction usually is either impact-resistant shutters installed over glazed openings or impact-resistant glazing. The IRC still permits the use of wood structural panels (plywood or oriented strand board [OSB]) as opening protection for glazing in one- and two-story buildings to resist impacts from wind-borne debris. To use wood structural panels for opening protection, however, attachment hardware is required, with anchors permanently installed on the building. Impact-resistant glazing or protective devices must be tested using an approved test method, such as ASTM E1886 (ASTM, 2005) and ASTM E1996 (ASTM, 2009b).

Just what defines impact resistance and the level of impact risk during a hurricane continues to be the subject of much debate. Surveys of damage following major hurricanes have identified several factors that affect the level of debris impact risk, including

- wind climate (design wind speed);
- exposure (for example, suburban, wooded, height of surrounding buildings);
- development density (that is, distance between buildings);
- construction characteristics (for example, type of roofing, degree of wind resistance); and
- debris sources (for example, roofing, fencing, and gravel).

Current standards for selecting impact criteria for wind-borne debris protection do not explicitly consider all of those factors. Further, the primary debris source in typical residential developments is asphalt roof shingles, clay roof tiles, landscaping materials and driveway gravel, vinyl siding, and vegetation from trees and shrubs, some of which are not represented in existing impact test methods. Recent research has provided insight into performance expectations (Fernandez, Masters, and Gurley, 2010; Masters et al., 2010). These factors have a dramatic effect on the level of wind-borne debris risk. Table 3.11 presents an example of missile types used for current impact tests. Additional factors to consider include emergency egress or access in the event of fire when impact-resistant glazing or fixed shutter systems are specified, potential injury or misapplication during installation of temporary methods of window protection, and durability of protective devices and connection details (including installation quality) such that they themselves do not become a debris hazard over time.

TABLE 3.11 *Missile Types for Wind-Borne Debris Impact Tests*^{1,2}

Description	Velocity	Energy
2 gram steel balls	130 fps	10 ft-lb
4.5 lb 2x4	40 fps	100 ft-lb
9.0 lb 2x4	50 fps	350 ft-lb

fps = feet per second; ft-lb = foot-pounds; lb = pounds

¹Consult ASTM E1886 (ASTM, 2005) for guidance on testing apparatus and methodology.

²These missile types are not necessarily representative of the predominant types or sources of debris at any particular site. The steel balls are intended to represent small gravel that would be commonly used for roof ballast. The 2x4 missiles are intended to represent a direct, end-on blow from construction debris.

Homes that experience wind-borne debris damage may exhibit more catastrophic failures, such as a roof blowoff, but usually this occurs only when large elements of the building envelope fail, such as large windows or garage doors. Wind pressure can also cause failures in these large elements; therefore, in hurricane-prone regions, large windows and garage doors should be specified that meet both wind pressure and wind-borne debris impact requirements, and the attachment of those elements to structural framing should be carefully designed.

One additional element that requires consideration, and for which research is being conducted, is wind-driven rain. Most window manufacturers have products tested to some limitation on water infiltration, and under normal weather conditions those limitations usually are sufficient (usually up to 15 percent of the design wind pressure). Hurricane-force winds will drive rain horizontally and that water can penetrate between window units, under doors, and into soffits and other small places such that, even with attention to this issue, the water can cause significant damage. Both the designer and the builder must pay attention to the construction details at every building joint and every hole in the building envelope to ensure that water penetration during high winds is minimized (Salzano, Masters, and Katsaros, 2010).

3.6.3.2 Tips to Improve Performance

The following design and construction tips are simple considerations for reducing a building's vulnerability to hurricane wind damage:

- One-story buildings are less vulnerable than two- or three-story buildings to wind damage.
- On average, hip roofs have demonstrated better performance than gable-end roofs.
- Moderate roof slopes (that is, 5:12 to 6:12) tend to optimize the tradeoff between lateral loads and roof uplift loads (that is, they are aerodynamically efficient).
- Roof sheathing installation should be inspected for the proper type and spacing of fasteners, particularly at connections to gable-end framing.
- The installation of metal strapping or other tie-down hardware should be inspected as required to ensure the transfer of uplift loads.
- If composition roof shingles are used, the shingles should be tested in accordance with ASTM D7158 (ASTM, 2011). All roof coverings should be designed or tested and installed to resist the applicable wind loads.

- Glazed-opening protection should be considered in the most severe hurricane-prone areas and in those areas defined as requiring wind-borne debris protection.
- The roof deck may be sealed or a secondary water barrier may be installed on the roof to prevent water infiltration in the event the primary roof covering is blown off. A sealed roof deck can be created by installing minimum 4-inch-wide strips of self-adhering underlayment complying with ASTM D1970 over the roof sheathing joints (ASTM, 2009c). The IRC also contains enhanced underlayment specifications for high-wind regions that require the use of ASTM D226 Type II (30 pound) or equivalent underlayment with a rigorous fastening schedule (ASTM, 2009a).

The HUD document *Safer, Stronger Homes* (HUD, 2011) includes further details regarding methods for improving the wind hazard resilience of new and existing residential structures.

3.7 Snow Loads

For design purposes, snow typically is treated as a simple uniform gravity load on the horizontal projected area of a roof. The uniformly distributed design snow load on residential roofs can be easily determined by using the unadjusted ground snow load. This simple approach also represents standard practice in some regions of the United States; however, it does not account for a reduction in roof snow load that may be associated with steep roof slopes with slippery surfaces (refer to ASCE 7-10). Drift loads on sloped gable or hip roofs must consider roof slope, warm and cold roof slope factors, and ridge-to-eave distances. ASCE 7-10 has design parameters for each of these snow and roof conditions. Drifting snow has caused numerous roof failures in the past 5 to 10 years. The design guidance in ASCE 7 addresses some of the issues important to consider for drifting snow; for building design, drifting snow must be considered at any building intersection where a roof adjoins a wall or other vertical surface where snow can accumulate. For buildings, snow drifting can occur where a building extension such as a garage or first floor addition adjoins an existing two-story wall. The problem of loading is complicated because snow loads vary with moisture content as well as depth, and depths vary with roof slope, wind speed, and vertical height where drifting can occur.

Design ground snow loads may be obtained from the map in figure 3.3 (for a larger ground snow load map with greater detail, refer to ASCE 7-10); however, snow loads usually are defined by the local building department. Typical ground snow loads range from 0 psf in the southern United States to 50 psf in the northern United States. In mountainous areas, the ground snow load can surpass 100 psf, so local snow data must be carefully considered. The ASCE 7-10 map includes varying ground snow loads with ground elevation above sea level. In areas where the ground snow load is less than 15 psf, the minimum roof live load (refer to section 3.4) usually is the controlling gravity load in roof design.

FIGURE 3.3a *Ground Snow Loads (ASCE 7-10)*

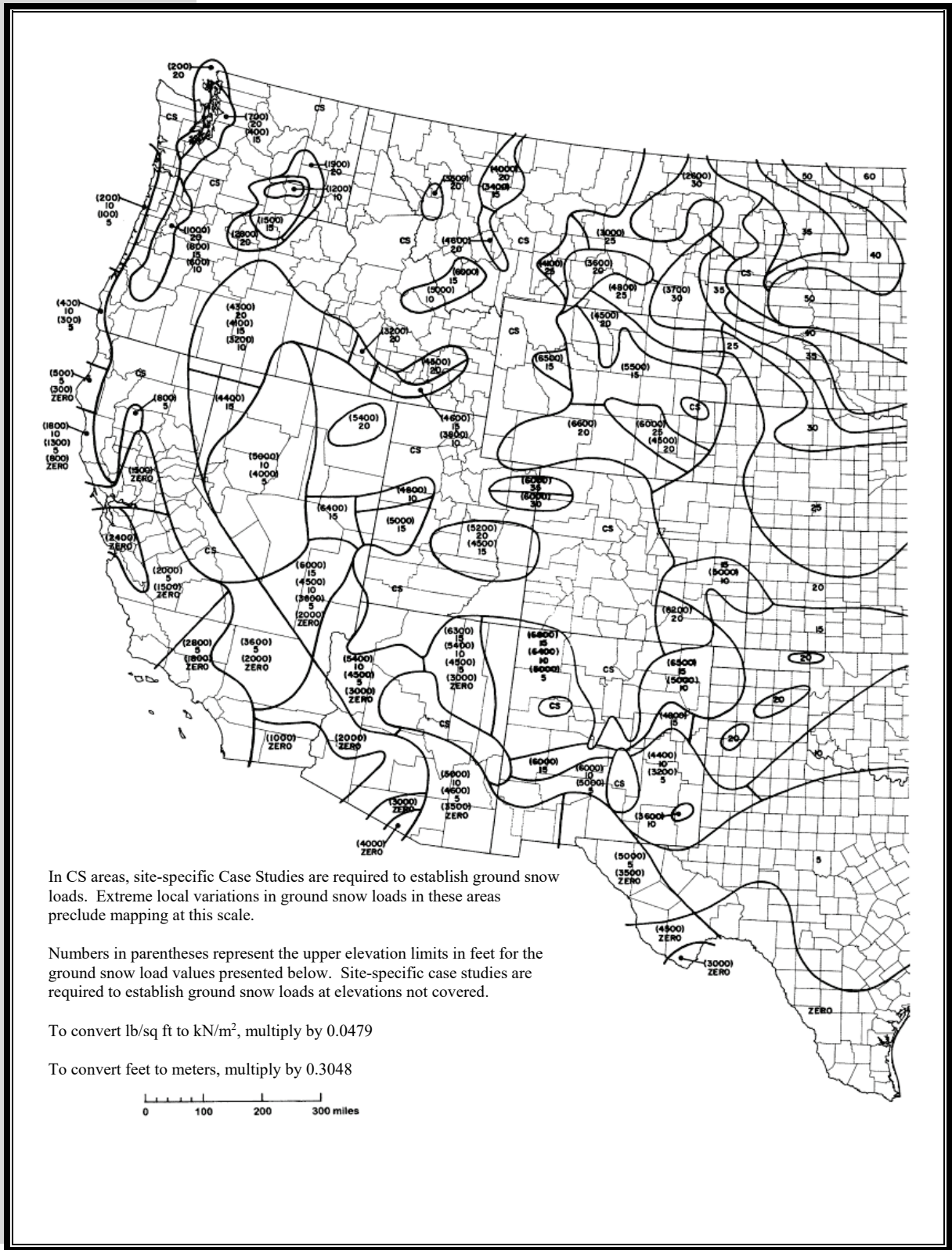

In CS areas, site-specific Case Studies are required to establish ground snow loads. Extreme local variations in ground snow loads in these areas preclude mapping at this scale.

Numbers in parentheses represent the upper elevation limits in feet for the ground snow load values presented below. Site-specific case studies are required to establish ground snow loads at elevations not covered.

To convert lb/sq ft to kN/m², multiply by 0.0479

To convert feet to meters, multiply by 0.3048

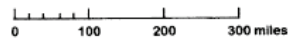

Source: Reprinted with permission from the American Society of Civil Engineers, 1801 Alexander Bell Road, Reston, VA. Copyright ASCE.

FIGURE 3.3b *Ground Snow Loads (ASCE 7-10)*

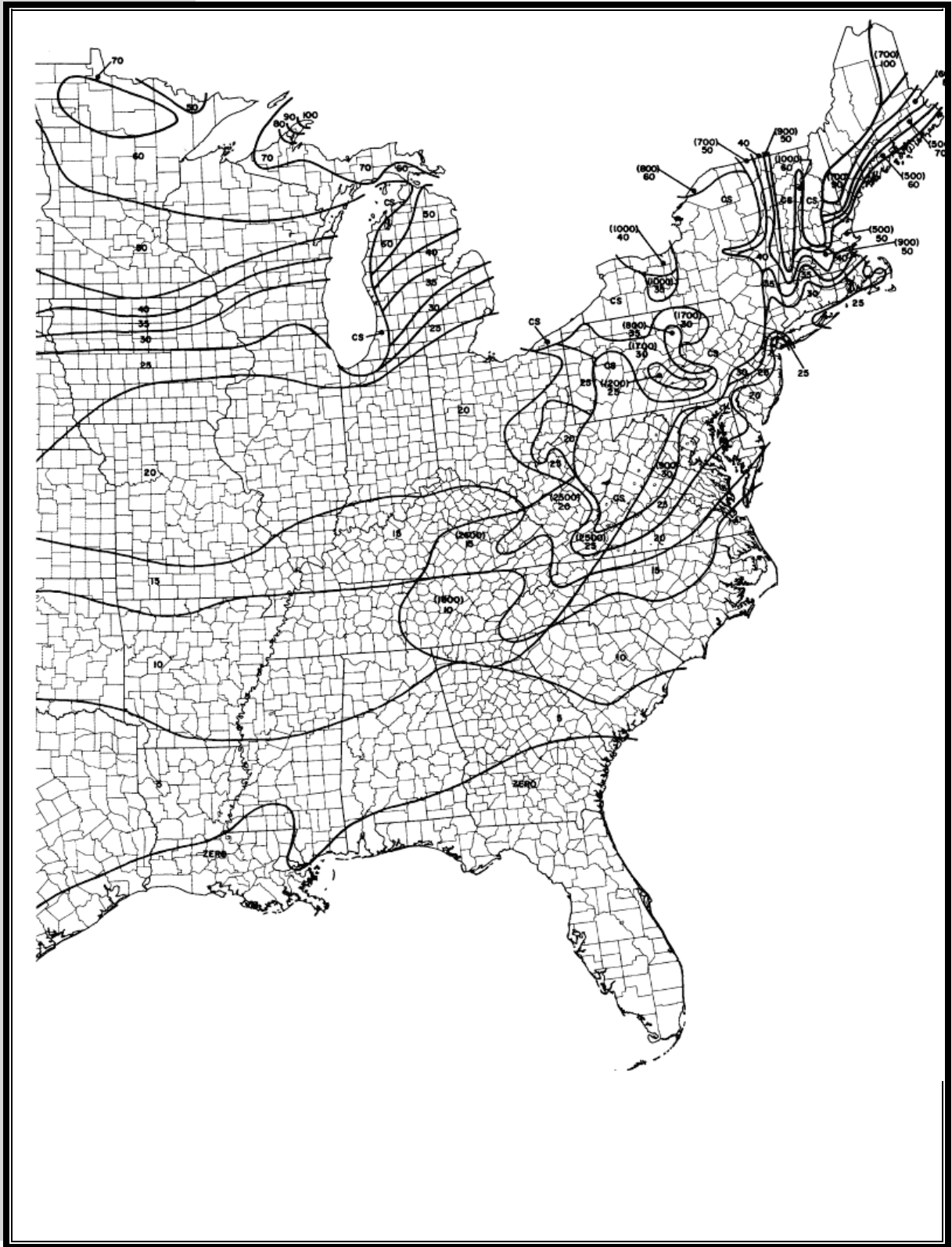

Source: Reprinted with permission from the American Society of Civil Engineers, 1801 Alexander Bell Road, Reston, VA. Copyright ASCE.

3.8 Earthquake Loads

3.8.1 General

This section provides a simplified earthquake load analysis procedure appropriate for use in residential light-frame construction of not more than three stories above grade. As described in chapter 2, the lateral forces associated with seismic ground motion are based on fundamental Newtonian mechanics ($F = ma$), expressed in terms of an equivalent static load. The method provided in this section is a simplification of the most current seismic design provisions *NEHRP (National Earthquake Hazards Reduction Program) Recommended Seismic Provisions for New Buildings and Other Structures* (FEMA, 2009a). The method herein also is similar to a simplified approach found in more recent building codes (ICC, 2012).

In general, wood-framed homes have performed well from a life safety standpoint in major seismic events, probably because of, among other factors, their lightweight and resilient construction, the strength provided by nonstructural systems such as interior walls, and their load distribution capabilities. Wood-framed homes have not performed as well from a damage-reduction standpoint, in part because of brittle finishes such as gypsum board and masonry exteriors, as well as insufficient anchorage of wall framing to foundations, lack of sheathing on cripple walls, and slope failures on hillside sites (HUD, 1994). Garages with wide doors or houses with many large windows on the ground floor can fail as a result of so-called “soft story” or “weak story” behavior because the garage or ground floor walls are much less stiff than the roof or stories above.

FIGURE 3.4a

Mapped Risk-Targeted Maximum Considered Earthquake (MCE_R) Spectral Response Acceleration

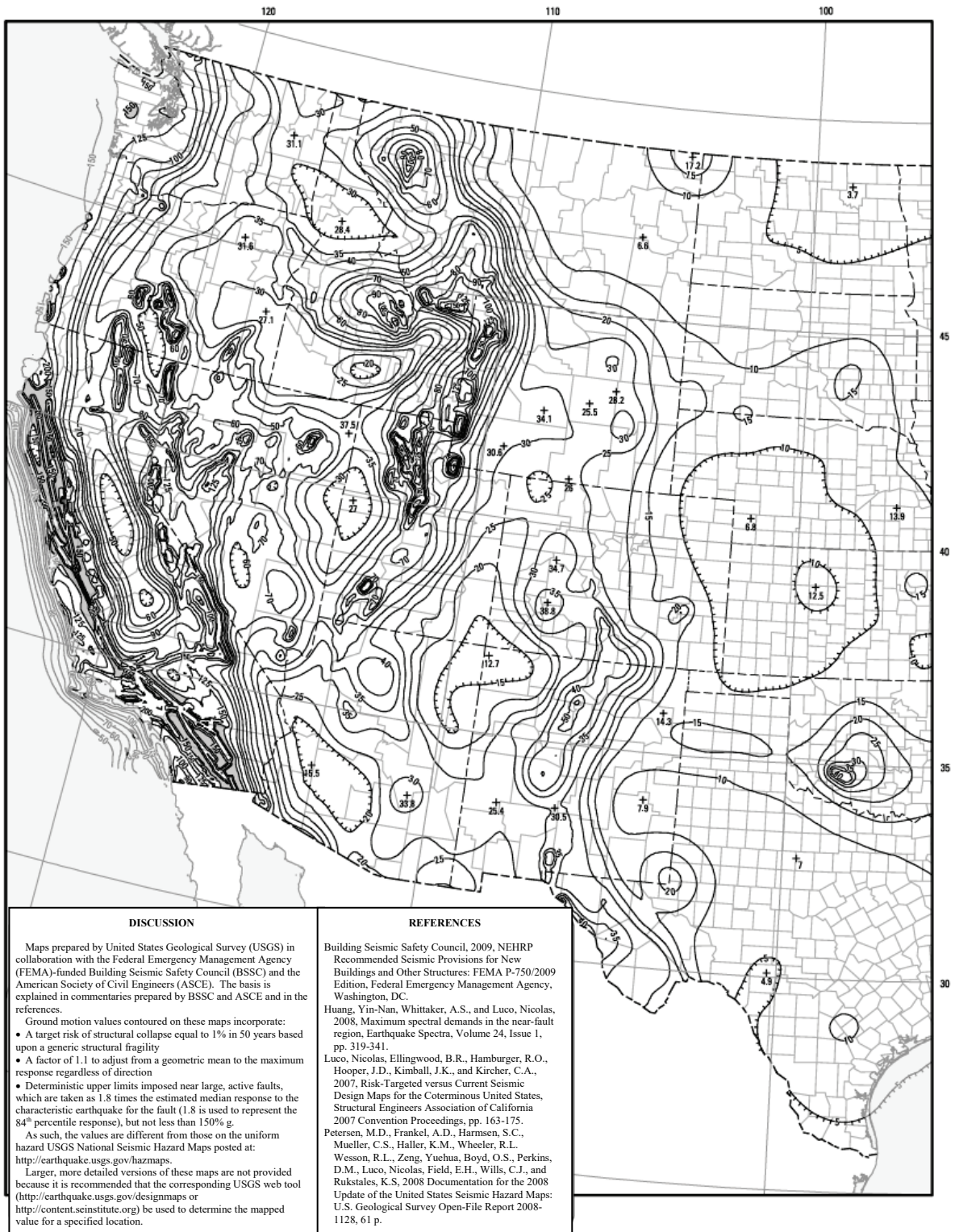

Source: Reprinted with permission from the American Society of Civil Engineers, 1801 Alexander Bell Road, Reston, VA. Copyright ASCE.

FIGURE 3.4b

Mapped Risk-Targeted Maximum Considered Earthquake (MCE_R) Spectral Response Acceleration

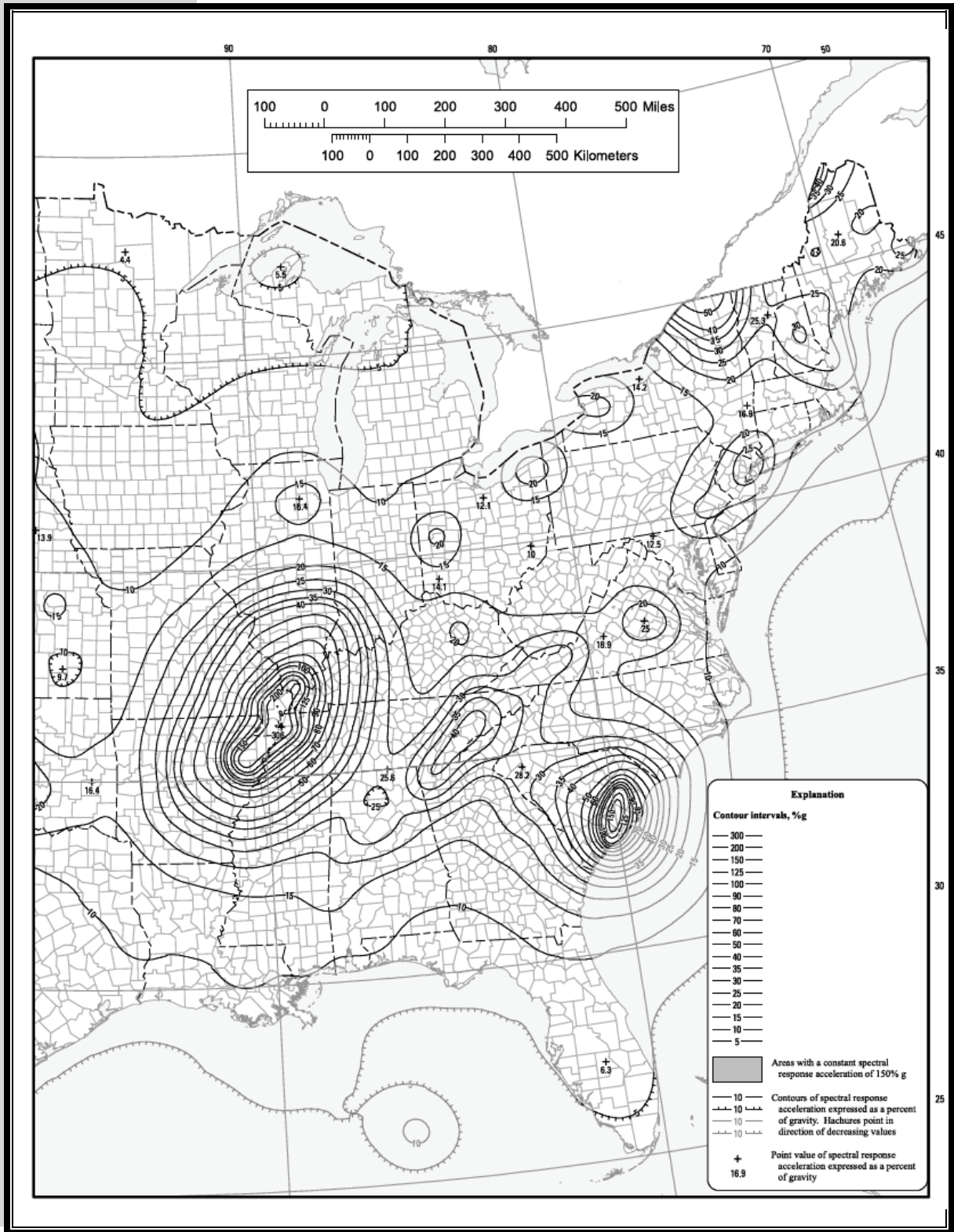

Source: Reprinted with permission from the American Society of Civil Engineers, 1801 Alexander Bell Road, Reston, VA. Copyright ASCE.

3.8.2 Determination of Earthquake Loads on Houses

The total lateral force at the base of a building is called seismic base shear. The lateral force experienced at a particular story level is called the story shear. The story shear is greatest in the ground story and least in the top story. Seismic base shear and story shear (V) are determined in accordance with the following equation:

Equation 3.8-1

$$V = \frac{S_{DS}}{\left(\frac{R}{I_e}\right)} W,$$

where

- S_{DS} = the design spectral response acceleration in the short-period range determined by equation 3.8-2 (g)
- R = THE RESPONSE MODIFICATION FACTOR (DIMENSIONLESS)
- W = the effective seismic weight of the building or supported by the story under consideration (lb); 20 percent of the roof snow load is also included where the ground snow load exceeds 30 psf
- I_e = importance factor, which is 1.0 for residential buildings.

When determining story shear for a given story, the designer attributes to that story one-half of the dead load of the walls on the story under consideration and the dead load supported by the story (dead loads used in determining seismic story shear or base shear are found in section 3.3). For housing, the interior partition wall dead load is reasonably accounted for by the use of a 6 psf load distributed uniformly over the floor area. When applicable, the snow load may be determined in accordance with section 3.7. The inclusion of any snow load, however, is based on the assumption that the snow is always frozen solid and adhered to the building such that it is part of the building mass during the entire seismic event.

The design spectral response acceleration for short-period ground motion S_{DS} typically is used because light-frame buildings such as houses are believed to have a short period of vibration in response to seismic ground motion (that is, high natural frequency). For example, the building tested as part of the NEESWood project in 2006 (Filiatrault et al., 2010) had an elastic period of 0.21 seconds, consistent with the 0.2-second period used to establish the short-period ground motions.

Values of S_{MS} are from figure 3.4. For a larger map with greater detail, refer to ASCE 7-10 or find the response accelerations using the U.S. Geological Survey (USGS) seismic design maps, based on either latitude and longitude or zip codes: <http://earthquake.usgs.gov/hazards/designmaps/usdesign.php>. The value of S_{DS} should be determined in consideration of the mapped short-period spectral response acceleration S_{MS} and the required soil site amplification factor F_a as follows:

Equation 3.8-2

$$S_{DS} = 2/3(S_{MS})(F_a)$$

The value of S_{MS} ranges from practically zero in low-risk areas to 3g in the highest risk regions of the United States. A typical value in high seismic areas is 1.5g. In general, wind loads control the design of the LFRS of light-frame houses when S_{MS} is low.

Table 3.12 provides the values of F_a associated with a standard “firm” soil condition used for the design of residential buildings. F_a decreases with increasing ground motion because the soil begins to dampen the ground motion as shaking intensifies. The soil can therefore have a moderating effect on the seismic shear loads experienced by buildings in high-seismic-risk regions. Dampening also occurs between a building foundation and the soil and thus has a moderating effect. The soil-structure interaction effects on residential buildings have been the topic of little study; therefore, precise design procedures have yet to be developed. If a site is located on fill soils or “soft” ground, a different value of F_a should be considered (see ASCE, 2010, for the full table). Nonetheless, as noted in the Anchorage Earthquake of 1964 and again 30 years later in the Northridge Earthquake, soft soils do not necessarily affect the performance of the aboveground house structure as much as they affect the site and foundations (for example, by settlement, fissuring, or liquefaction).

TABLE 3.12 *Site Soil Amplification Factor Relative to Acceleration (short period, Site Class D)*

Short-Period Spectral Response Acceleration, S_{MS}	≤ 0.25g	0.5g	0.75g	1.0g	≥ 1.25g
Site Soil Amplification Factor, F_a	1.6	1.4	1.2	1.1	1.0

The seismic response factor R has a long history in seismic design but with little in the way of scientific underpinnings until recently (FEMA, 2009b). In fact, the R factor can be traced back to expert opinion in the development of seismic design codes during the 1950s (ATC, 1995). In recognition that buildings can effectively dissipate energy from seismic ground motions through ductile damage, the R factor was conceived to adjust the shear forces from that which would be experienced if a building could exhibit perfectly elastic behavior without some form of ductile energy dissipation (Chopra, 2012).

Those structural building systems that are able to withstand greater ductile damage and deformation without substantial loss of strength are assigned a higher value for R . The R factor also incorporates differences in dampening that are believed to occur for various structural systems. Table 3.13 provides some values for R that are relevant to residential construction. The *Quantification of Building Seismic Performance Factors FEMA P-695* (FEMA, 2009b) methodology allows one to develop an R factor for a new LFRS based on the margin against collapse.

The overstrength factor Ω_0 addresses the idea that a shear resisting system's ultimate capacity usually is significantly higher than required by the design load as a result of intended safety margins. Designers incorporate overstrength factors in an attempt to address the principle of balanced design, striving to ensure that components such as connections have sufficient capacity to allow the LFRS to act in its intended ductile manner. These factors are applied at the load combination stage of force development.

The deflection amplification factor C_d is applied to adjust the deflection of story drift, which is determined by use of the seismic shear load as adjusted downward by the R factor. The use of this amplification factor will likely produce a conservative result of expected drift; drift calculations rarely are required in lowrise light-frame buildings because code-required drift limits have not been established for these structure types.

TABLE 3.13 ***Seismic Design Factors for Residential Construction***

Structural System	Response Modification Coefficient, R^1	Overstrength factor, Ω_0	Deflection Amplification Factor, C_d
Light-frame (wood) walls sheathed with wood structural panels rated for shear resistance or steel sheets	6.5	3	4
Light-frame shear walls with shear panels of all other materials	2.0	2.5	2
Special reinforced concrete shear walls ²	5.0	2.5	5
Special reinforced masonry shear walls ²	5.0	2.5	3.5
Ordinary plain concrete shear walls	1.5	2.5	1.5
Ordinary plain masonry shear walls	1.5	2.5	1.25

Notes:

¹The R factors may vary for a given structural system type depending on wall configuration, material selection, and connection detailing.

²The wall is reinforced in accordance with concrete design requirements in ACI-318 or ACI-530. Nominally reinforced concrete or masonry that has conventional amounts of vertical reinforcement, such as one #5 rebar at openings and at 4 feet on center, may use the value for reinforced walls, provided the construction is no more than two stories above grade.

Design example 3.3 in section 3.12 demonstrates the calculation of design seismic shear load based on the simplified procedures (the reader is referred to chapter 6 for additional information on seismic loads and analysis).

3.8.3 Seismic Shear Force Distribution

As described in the previous section, the *vertical distribution* of seismic forces to separate stories on a light-frame building is assumed to be in accordance with the mass supported by each story. The lateral seismic force, F_x , induced at any level, is determined as

Equation 3.8-3

$$F_x = C_{vx}V, \text{ and}$$

$$C_{vx} = \frac{w_x h_x}{\sum_{i=1}^n w_i h_i}$$

Where:

C_{vx}	=	vertical distribution factor
V	=	total base shear
w_i	=	portion of the total effective seismic weight of the structure at level i
w_x	=	portion of the total effective seismic weight of the structure at level x
h_i	=	height from the base to level i
h_x	=	height from the base to level x

The *horizontal distribution* of seismic forces to various shear walls on a given story also varies in current practice for light-frame buildings. In chapter 6, several existing approaches to the design of the LFRS of light-frame houses address the issue of horizontal force distribution, with varying degrees of sophistication. Until methods of vertical and horizontal seismic force distribution are better understood for application to light-frame buildings, the importance of designer judgment cannot be overemphasized.

3.8.4 Other Seismic Design Considerations

Perhaps the single most important principle in seismic design is ensuring that the structural components and systems are adequately tied together to perform as a structural unit. Underlying this principle are a host of analytic challenges and uncertainties in actually defining what “adequately tied together” means in a repeatable, accurate, and theoretically sound manner.

Irregularities in the building shape are a key design consideration. Irregularities can occur in plan and in elevation. Plan irregularities can create torsional imbalances, thus requiring designs for moment distribution. Vertical irregularities are often stiffness irregularities, such as “soft stories,” “weak stories,” or “heavy stories.” Sometimes the vertical discontinuities can create unusual distribution of shear between LFRS.

When diaphragms are not flexible, the design should include the inherent torsional moment, M_t , resulting from the location of the structural masses plus the accidental torsional moment, M_{ta} , caused by assumed displacement of the center of mass each way from its actual location by a distance equal to 5 percent of the dimension of the structure perpendicular to the direction of the applied forces. Overturning must be anticipated in the design, and the

structure must be designed to resist such forces. Story drift is computed as the largest difference of the deflections aligned vertically at the top and bottom of the story under consideration. The design story drift at level x is computed as

$$\delta_x = \left(\frac{C_d \delta_{xe}}{I_e} \right)$$

where C_d is the deflection amplification factor from table 3.12, δ_{xe} is the deflection at the location of interest determined by elastic analysis, and I_e is the importance factor, which is 1.0 for residential buildings.

For one- and two-story dwellings, the diaphragms are assumed to be flexible. Rigid diaphragms usually are those constructed of concrete or concrete-filled metal deck. ASCE 7-10 has a set of conditions that are used to determine whether a diaphragm is flexible or rigid.

A key issue related to building damage involves *deformation compatibility* of materials and detailing in a constructed system. This issue may be handled through specification of materials that have similar deformation capabilities or by system detailing that improves compatibility. For example, a relatively flexible hold-down device installed near a rigid sill anchor causes greater stress concentration on the more rigid element, as evidenced by the splitting of wood sill plates in the Northridge Earthquake. The solution can involve increasing the rigidity of the hold-down device (which can lessen the ductility of the system, increase stiffness, and effectively increase seismic load) or redesigning the sill plate connection to accommodate the hold-down deformation and improve load distribution. Researchers in a FEMA-funded CUREE-CalTech project developed a solution for the sill plate connection: a 3-inch-square washer for use on the sill plate anchor bolt. As a nonstructural example of deformation compatibility, gypsum board interior finishes crack in a major seismic event well before the structural capability of the wall's structural sheathing is exhausted. Conversely, wood exterior siding and similar resilient finishes tend to deform compatibly with the wall and limit unacceptable visual damage (HUD, 1994).

3.9 Flood Loads

A significant level of construction occurs in the nation's floodplains, so the design professional should be acquainted with the regulations and the design constraints required for building in these areas. The basic design premise for a flood condition is either to elevate the structure above the expected flood level or to build outside the regulatory floodplain. The full explanation of floodplain regulations is beyond the scope of this document; however, the following issues are important for all designers of buildings in floodplains:

- Floodplain regulations are local, so local zoning and/or building codes govern any construction in a floodplain.
- Local ordinances define the regulatory flood elevation, but it usually is the Base Flood Elevation (BFE), defined as the 1-percent annual exceedance probability flood. Frequently the community requires a certain number of feet of freeboard above the BFE to provide a margin of safety.

- The BFE usually is shown on a Flood Insurance Rate Map (FIRM), and this map is available either locally or digitally at FEMA’s Map Service Center.
- Minimum construction standards exist for buildings located in floodplains, and these standards govern elevation of the lowest living floor, the type of foundation that can be constructed, and the materials that can be used below the BFE.

Equations for flood loads are provided in ASCE 7, chapter 5, and for coastal flood conditions, flood formulas are available in FEMA’s *Coastal Construction Manual* (FEMA, 2011a) or in the United States Army Corps of Engineers *Coastal Engineering Manual* (USACE, 2009). Details specific to residential construction can be found in FEMA’s *Home Builder’s Guide to Coastal Construction* (FEMA, 2011b).

ASCE 24, the *Flood Resistant Design and Construction* standard, also contains significant flood design information. This standard does not include any information about flood loads but does suggest flood elevations for various building occupancies and provides design guidance for building issues from foundations to utilities.

3.10 Tornadoes

A tornado is a narrow, violently rotating column of air that extends from the base of a thunderstorm to the ground. They are the most violent of all atmospheric storms. Tornadoes occur in many parts of the world, but most of them by far occur in the United States, which experiences on average about 1,200 tornadoes per year (NCDC, 2013). Still, a direct tornado strike on a building is a relatively rare event, and the annual probability is lower than for other natural hazard events (that is $1.87E-4$ for a tornado strike of any intensity [Ramsdell et al., 2007] vs. $1.43E-3$ for hurricane design wind speeds [ASCE, 2010]). Despite their small size, tornadoes can travel great distances and thus cause destruction to several communities within their path.

Building codes do not provide design guides for tornado loads for two reasons: (1) the rarity of the event and (2) the extreme magnitude of the tornado loads. The media report numerous opinions about whether building codes should cover that type of low probability, high consequence event. Many people believe that it would be economically unfeasible to design houses to resist the expected 200 mph and higher wind speeds produced in tornadoes. Substantial evidence also exists, however, that much damage could be reduced even when communities are struck by extremely violent (EF-4 and EF-5) tornadoes. The Enhanced Fujita (EF) scale is used to classify tornadoes by wind speed, using damage as the indicator of that speed. Examination of damage suggests that such extensive devastation is the result of inadequate structural systems in homes that were not designed for—and are incapable of resisting—any significant wind load. The damage report for a 1970 Lubbock tornado concluded that although the maximum estimated wind speed was 200 mph, the majority of building damage was caused by winds that were only in the 75-to-125 mph range (Mehta et al., 1971).

The interest in developing tornado-resilient design of housing and other structures has gained interest recently following several years (for example, 2011 and

2013) in which violent tornadoes have hit large, densely populated areas. The economic losses attributed to tornadoes since 2000 amount to 15 percent of the economic losses from hurricanes over that same period (NWS, 2013). Despite the low probability of tornado occurrences, the consequences are fairly high when a community is impacted by one of these natural hazard events.

The unique wind loads produced by an extreme tornado (that is, an EF-5 on the Enhanced Fujita scale) will exceed typical design wind loads, particularly in interior portions of the country, where tornadoes are most common but where design wind speeds typically are 115 mph. Most tornadoes, though, are not the most devastating kind; more than 90 percent of all tornadoes are classified as an EF-2 or lower on the EF Scale. Further, detailed analysis of the damage paths of recent violent tornadoes have shown that nearly 90 percent of the damage paths experience wind speeds at or less than the intensity of an EF-2 tornado (Prevatt et al., 2012). Applying the concepts used for hurricane design to buildings located in tornado-prone areas can reduce damage from the lowest wind speed tornadoes.

Tornado loads differ from typical straightline wind events such as hurricanes in that the loads are a superposition of the aerodynamic effects of the wind passing over and around the building and the significant pressure drop within the vortex of the tornado. In combination, these two effects can produce loads on the building in a tornado that are nearly three times higher than those for a straightline wind event with equivalent wind speed (Haan et al, 2010). Many factors affect the magnitude of tornado loads, however, including the tornado size, translation speed, approach angle, and air leakage through the impacted structure. The contributions of each effect have only recently been quantified. As a result, little current information exists for designing structures to survive tornado events. The next version of the commentary on the ASCE 7 standard will likely have some information that will help designers incorporate some level of tornado resistance in their designs. For the most severe events, such as those created by EF-4 or EF-5 tornadoes, a safe room or shelter built to FEMA guidance or ICC standards affords the best life safety protection. ICC 500 (ICC, 2008) is a *Standard for the Design and Construction of Storm Shelters*; tornado safe room guidance is available in FEMA P-320 (FEMA, 2008b) and community shelter guidance is available in FEMA P-361 (FEMA, 2008a). These safe room and shelter guidance documents and standards have substantial design information about what wind speeds should be used for design and how to modify the wind pressure equation in ASCE 7 to accommodate the differences in the tornado wind structure compared to the hurricane or thunderstorm wind structure.

3.11 Other Load Conditions

In addition to the loads covered in sections 3.3 through 3.10 that are typically considered in the design of a home, other “forces of nature” may create loads on buildings. Some examples include

- frost heave;
- expansive soils; and
- temperature effects.

In certain cases, forces from these phenomena can drastically exceed reasonable design loads for homes. For example, frost heave forces can easily exceed 10,000 psf (Linell and Lobacz, 1980). Similarly, the force of expanding clay soil can be impressive. The self-straining stresses induced by temperature-related expansion or contraction of a member or system that is restrained against movement can be very large, although those stresses are not typically a concern in wood-framed housing.

Sound design detailing is common practice to reduce or eliminate the load increases mentioned. For example, frost heave can be avoided by placing footings below a “safe” frost depth, building on nonfrost-susceptible materials, or using other frost protection methods (see chapter 4). Expansive soil loads can be avoided by isolating building foundations from expansive soil, supporting foundations on a system of deep pilings, and designing foundations that provide for differential ground movements. Temperature effects can be eliminated by providing construction joints that allow for expansion and contraction. Although such temperature effects on wood materials are practically negligible, some finishes, such as ceramic tile, can experience cracking when inadvertently restrained against small movements resulting from variations in temperature.

As noted at the beginning of this chapter, this guide does not address loads from ice, rain, and other exceptional sources. The reader is referred to ASCE 7 and other resources for information regarding special load conditions (ASCE, 2010).

3.12 Design Examples

EXAMPLE 3.1

Design Gravity Load Calculations and Use of ASD Load Combinations

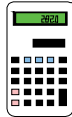

Given

Three-story conventional wood-framed home
28' x 44' plan, clear-span roof, floors supported at mid-span
Roof dead load = 15 psf (table 3.2)
Wall dead load = 8 psf (table 3.2)
Floor dead load = 10 psf (table 3.2)
Roof snow load = 16 psf (section 3.7)
Attic live load = 10 psf (table 3.4)
Second- and third-floor live load = 30 psf (table 3.4)
First-floor live load = 40 psf (table 3.4)

Find

Gravity load on first-story exterior bearing wall
Gravity load on a column supporting loads from two floors

Solution

1. Gravity load on first-story exterior bearing wall

- Determine loads on wall

$$\begin{aligned}\text{Dead load} &= \text{roof DL} + 2 \text{ wall DL} + 2 \text{ floor DL} \\ &= 1/2 (28 \text{ ft})(15 \text{ psf}) + 2(8 \text{ ft})(8 \text{ psf}) + 2(7 \text{ ft})(10 \text{ psf}) \\ &= 478 \text{ plf}\end{aligned}$$

Floor span assumes a center support wall, thus load on exterior wall is 28'/4

$$\begin{aligned}\text{Roof snow} &= 1/2(28 \text{ ft})(16 \text{ psf}) = 224 \text{ plf} \\ \text{Live load} &= (30 \text{ psf} + 30 \text{ psf})(7 \text{ ft}) = 420 \text{ plf} \\ &\text{(two floors)} \\ \text{Attic live load} &= (10 \text{ psf})(14 \text{ ft} - 5 \text{ ft}^*) = 90 \text{ plf} \\ &\text{*edges of roof span not accessible to roof storage} \\ &\text{because of low clearance}\end{aligned}$$

- Apply applicable ASD load combinations (table 3.1)

$$D + 0.75L + 0.75S$$

$$\begin{aligned}\text{Wall axial gravity load} &= 478 \text{ plf} + 0.75*420 \text{ plf} + 0.75*224 \text{ plf} \\ &= 961 \text{ plf}^*\end{aligned}$$

*equals 1,029 plf if full attic live load allowance is included with L

The same load applies to the design of headers as well as to the wall studs. Of course, combined lateral (bending) and axial loads on the wall studs also must be checked (that is, D+W); refer to table 3.1 and example 3.2. For non-load-bearing exterior walls (that is, gable-end curtain walls), contributions from floor and roof

live loads may be negligible (or significantly reduced), and the D+W load combination likely governs the design.

2. Gravity load on a column supporting a center floor girder carrying loads from two floors (first and second stories)

- Assume a column spacing of 16 ft
- Determine loads on column

$$\begin{aligned} \text{(a) Dead load} &= \text{Second floor} + \text{first floor} + \text{bearing wall supporting second floor} \\ &= (14 \text{ ft})(16 \text{ ft})(10 \text{ psf}) + (14 \text{ ft})(16 \text{ ft})(10 \text{ psf}) + (8 \text{ ft})(16 \text{ ft})(7 \text{ psf}) \\ &= 5,376 \text{ lbs} \end{aligned}$$

(b) Live load area reduction (equation 3.4-1)

$$\begin{aligned} \text{- supported floor area} &= 2(14 \text{ ft})(16 \text{ ft}) = 448 \text{ ft}^2 \text{ per floor} \\ \text{- reduction} &= \left[0.25 + \frac{15}{\sqrt{4 * 448}} \right] = 0.6 > 0.5 \end{aligned}$$

OK

$$\begin{aligned} \text{- first-floor live load} &= 0.6 (40 \text{ psf}) = 24 \text{ psf} \\ \text{- second-floor live load} &= 0.6 (30 \text{ psf}) = 18 \text{ psf} \end{aligned}$$

$$\begin{aligned} \text{(c) Live load} &= (14 \text{ ft})(16 \text{ ft})[24 \text{ psf} + 18 \text{ psf}] \\ &= 9,408 \text{ lbs} \end{aligned}$$

- Apply ASD load combinations (table 3.1)

The controlling load combination is D+L because the column supports no attic or roof loads. The total axial gravity design load on the column is 14,748 lbs (5,376 lbs + 9,408 lbs).

Note: If LRFD material design specifications are used, the various loads would be factored in accordance with table 3.1; all other considerations and calculations remain unchanged.

EXAMPLE 3.2

Design Wind Load Calculations and Use of ASD Load Combinations

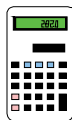

Given

Site wind speed: 120 mph, gust
 Site wind exposure: suburban
 Two-story home, 7:12 roof pitch, 28' x 44' plan (rectangular), gable roof, 12-inch overhang

Find

Lateral (shear) load on lower-story end wall
 Net roof uplift at connections to the side wall
 Roof sheathing pull-off (suction) pressure
 Wind load on a roof truss
 Wind load on a rafter

Lateral (out-of-plane) wind load on a wall stud

Solution

1. Lateral (shear) load on lower story end wall

- Step 1: LRFD velocity pressure = 22 psf (table 3. 8)
- Step 2: Adjusted velocity pressure (none required) = 22 psf
- Step 3: Lateral roof coefficient = 0.8 (interpolated from table 3.9)
Lateral wall coefficient = 1.1 (table 3.9)
- Step 4: Skip
- Step 5: Determine design wind pressures
Roof projected area pressure = (22 psf)(0.8) = 17.6 psf (LRFD)
Wall projected area pressure = (22 psf)(1.1) = 24.2 psf (LRFD)

Now determine vertical projected areas (VPA) for lower-story end-wall tributary loading (assuming no contribution from interior walls in resisting lateral loads).

$$\begin{aligned}\text{Roof VPA} &= [1/2 (\text{building width})(\text{roof pitch})] \times [1/2 (\text{building length})] \\ &= [1/2 (28 \text{ ft})(7/12)] \times [1/2 (44 \text{ ft})] \\ &= [8.2 \text{ ft}] \times [22 \text{ ft}] \\ &= 180 \text{ ft}^2\end{aligned}$$

$$\begin{aligned}\text{Wall VPA} &= [(\text{second-story wall height}) + (\text{thickness of floor}) + 1/2 (\text{first-story wall height})] \times [1/2 (\text{building length})] \\ &= [8 \text{ ft} + 1 \text{ ft} + 4 \text{ ft}] \times [1/2 (44 \text{ ft})] \\ &= [13 \text{ ft}] \times [22 \text{ ft}] \\ &= 286 \text{ ft}^2\end{aligned}$$

Now determine shear load on the first-story end wall.

$$\begin{aligned}\text{Shear} &= (\text{roof VPA})(\text{roof projected area pressure}) + (\text{wall VPA})(\text{wall projected area pressure}) \\ &= (180 \text{ ft}^2)(17.6 \text{ psf}) + (286 \text{ ft}^2)(24.2 \text{ psf}) \\ &= 10,089 \text{ lbs (LRFD) or } 10,089 \times 0.6 = 6,053 \text{ lbs (ASD)}\end{aligned}$$

The first-story end wall must be designed to transfer a shear load of 6,053 lbs. If side-wall loads were determined instead, the vertical projected area would include only the gable-end wall area and the triangular wall area formed by the roof. Use of a hip roof would reduce the shear load for the side and end walls.

2. Roof uplift at connection to the side wall (parallel-to-ridge)

- Step 1: Velocity pressure = 22 psf (as before) (LRFD)
- Step 2: Adjusted velocity pressure = 22 psf (as before)
- Step 3: Skip
- Step 4: Roof uplift pressure coefficient = -1.2 (table 3.10)
Roof overhang pressure coefficient = 0.7 (table 3.10)
- Step 5: Determine design wind pressure
Roof horizontal projected area (HPA) pressure = -1.2 (22 psf)
= -24.2 psf
Roof overhang pressure = 0.7 (22 psf) = 15.4 psf (upward)

Now determine gross uplift at roof-wall reaction.

$$\begin{aligned}
 \text{Gross uplift} &= 1/2 (\text{roof span})(\text{roof HPA pressure}) + (\text{overhang})(\text{overhang pressure coefficient}) \\
 &= 1/2 (30 \text{ ft})(-24.2 \text{ psf}) + (1 \text{ ft})(-15.4 \text{ psf}) \\
 &= -385 \text{ plf (upward)}
 \end{aligned}$$

$$\begin{aligned}
 \text{Roof dead load reaction} &= 1/2 (\text{roof span})(\text{uniform dead load}) \\
 &= 1/2 (30 \text{ ft})(15 \text{ psf}^*) \\
 &\quad \text{*table 3.2} \\
 &= 225 \text{ plf (downward)}
 \end{aligned}$$

Now determine net design uplift load at roof-wall connection.

$$\begin{aligned}
 \text{Net design uplift load} &= 0.6D + 0.6W_u \text{ (table 3.1)} \\
 &= 0.6 (225 \text{ plf}) + 0.6(-385 \text{ plf}) \\
 &= -96 \text{ plf (net uplift)}
 \end{aligned}$$

The roof-wall connection must be capable of resisting a design uplift load of 96 plf. Generally, a toenail connection will meet the design requirement, depending on the nail type, nail size, number of nails, and density of wall framing lumber (see chapter 7). At high design wind speeds or in more open wind exposure conditions, roof tie-down straps, brackets, or other connectors should be considered.

3. Roof sheathing pull-off (suction) pressure

$$\begin{aligned}
 \text{Step 1: Velocity pressure} &= 22 \text{ psf (as before)} \\
 \text{Step 2: Adjusted velocity pressure} &= 22 \text{ psf (as before)} \\
 \text{Step 3: Skip} & \\
 \text{Step 4: Roof sheathing pressure coefficient (suction)} &= -2.8 \text{ (table 3.10)} \\
 \text{Step 5: Roof sheathing pressure (suction)} &= (22 \text{ psf})(-2.8) \\
 &= -61.6 \text{ psf}
 \end{aligned}$$

The fastener load depends on the spacing of roof framing and spacing of the fastener. Fasteners in the interior of the roof sheathing panel usually have the largest tributary area and therefore are critical. Assuming 24-inch-on-center roof framing, the fastener withdrawal load for a 12-inch-on-center fastener spacing is as follows:

$$\begin{aligned}
 \text{Fastener withdrawal load} &= (\text{fastener spacing})(\text{framing spacing}) \\
 &\quad (\text{roof sheathing pressure}) \\
 &= (1 \text{ ft})(2 \text{ ft})(-61.6 \text{ psf}) \\
 &= -123.2 \text{ lbs (LRFD) or } 0.6 * 123.2 \\
 &= 73.9 \text{ lbs (ASD)}
 \end{aligned}$$

At high wind conditions, a closer fastener spacing or higher capacity fastener (that is, deformed shank nail) may be required; refer to chapter 7.

4. Load on a roof truss

$$\begin{aligned}
 \text{Step 1: Velocity pressure} &= 22 \text{ psf (as before)} \\
 \text{Step 2: Adjusted velocity pressure} &= 22 \text{ psf (as before)} \\
 \text{Step 3: Skip} & \\
 \text{Step 4: Roof truss pressure coefficient} &= -0.9, +0.4 \text{ (table 3.10)} \\
 \text{Step 5: Determine design wind pressures} &
 \end{aligned}$$

$$(a) \text{ Uplift} = -0.9 (22 \text{ psf}) = -19.8 \text{ psf}$$

$$(b) \text{ Inward} = 0.4 (22 \text{ psf}) = 8.8 \text{ psf}$$

Because the inward wind pressure is less than the minimum roof live load (that is, 15 psf, table 3.4), the following load combinations would govern the roof truss design, and the D+W load combination could be dismissed (refer to table 3.1):

$$D + (L_r \text{ or } S) \\ 0.6D + 0.6W_u^*$$

*The net uplift load for truss design is relatively small in this case (approximately 4.9 psf).

5. Load on a rafter

- Step 1: Velocity pressure = 22 psf (as before)
- Step 2: Adjusted velocity pressure = 22 psf (as before)
- Step 3: Skip
- Step 4: Rafter pressure coefficient = -1.2, +0.7 (table 3.10)
- Step 5: Determine design wind pressures

$$(a) \text{ Uplift} = (-1.2)(22 \text{ psf}) = -26.4 \text{ psf}$$

$$(b) \text{ Inward} = (0.7)(22 \text{ psf}) = 15.4 \text{ psf}$$

Rafters in cathedral ceilings are sloped, simply supported beams, whereas rafters that are framed with cross-ties (that is, ceiling joists) constitute a component (that is, top chord) of a site-built truss system. Assuming the former in this case, the rafter should be designed as a sloped beam by using the span measured along the slope. By inspection, the minimum roof live load ($D+L_r$) governs the design of the rafter in comparison to the wind load combinations (see table 3.1). The load combination $0.6 D+0.6 W_u$ can be dismissed in this case for rafter sizing but must be considered when investigating wind uplift for the rafter-to-wall and rafter-to-ridge beam connections.

6. Lateral (out-of-plane) wind load on a wall stud

- Step 1: Velocity pressure = 22 psf (as before)
- Step 2: Adjusted velocity pressure = 22 psf (as before)
- Step 3: Skip
- Step 4: Wall stud pressure coefficient = -1.2, +1.1 (table 3.10)
- Step 5: Determine design wind pressures

$$(a) \text{ Outward} = (-1.5)(22 \text{ psf}) = -33.0 \text{ psf}$$

$$(b) \text{ Inward} = (1.1)(22 \text{ psf}) = 24.2 \text{ psf}$$

Obviously, the outward pressure of 33.0 psf governs the out-of-plane bending load design of the wall stud. Because the load is a lateral pressure (not uplift), the applicable load combination is D+W (refer to table 3.1), resulting in a combined axial and bending load. The axial load would include the tributary building dead load from supported assemblies (that is, walls, floors, and roof). The bending load would then be determined by using the wind pressure of 33.0 psf applied to the stud as a uniform line load on a simply supported beam, calculated as follows:

$$\begin{aligned} \text{Uniform line load, } w &= (\text{wind pressure})(\text{stud spacing}) \\ &= (33.0 \text{ psf})(1.33 \text{ ft}^*) \\ &\quad \text{*assumes stud spacing of 16 inches on center} \\ &= 43.9 \text{ plf (LRFD)} \end{aligned}$$

Of course, the following gravity load combination would also need to be considered in the stud design (refer to table 3.1):

$$D + 0.75 L + 0.75 (L_r \text{ or } S)$$

The stud is actually part of a wall system (that is, sheathing and interior finish) and can add substantially to the calculated bending capacity; refer to chapter 5.

EXAMPLE 3.3

Design Earthquake Load Calculation

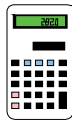

Given Site ground motion, $S_s = 1g$
 Site soil condition = firm (default)
 Roof snow load < 30 psf
 Two-story home, 28' x 44' plan, typical construction

Find Design seismic shear on first-story end wall, assuming no interior shear walls or contribution from partition walls

Solution

1. Determine tributary mass (weight) of building to first-story seismic shear.

Roof dead load = (28 ft)(44 ft)(15 psf) = 18,480 lb
 Second-story exterior wall dead load = (144 lf)(8 ft)(8 psf) = 9,216 lb
 Second-story partition wall dead load = (28 ft)(44 ft)(6 psf) = 7,392 lb
 Second-story floor dead load = (28 ft)(44 ft)(10 psf) = 12,320 lb
 First-story exterior walls (1/2 height) = (144 lf)(4 ft)(8 psf) = 4,608 lb
 Assume first-story interior partition walls are capable of supporting at least the seismic shear produced by their own weight

Total tributary weight = 52,016 lb

2. Determine total seismic story shear on first story.

$$\begin{aligned} S_{DS} &= \frac{2}{3} (S_s)(F_a) && \text{(equation 3.8-2)} \\ &= \frac{2}{3} (1.0g)(1.1) && (F_a = 1.1 \text{ from table 3.12}) \\ &= 0.74 g \end{aligned}$$

$$\begin{aligned} V &= W && \text{(equation 3.8-1)} \\ &= \frac{1.2(0.74g)}{5.5} (52,016 \text{ lb}) && (R = 5.5 \text{ from table 3.13}) \\ &= 8,399 \text{ lb} \end{aligned}$$

3. Determine design shear load on the 28-foot end walls.

Assume that the building mass is evenly distributed and that stiffness is also reasonably balanced between the two end walls; refer to chapter 6 for additional guidance.

With the above assumption, the load is simply distributed to the end walls

according to tributary weight (or plan area) of the building; therefore,

$$\text{End wall shear} = 1/2 (8,399 \text{ lb}) = 4,200 \text{ lb}$$

Note that the design shear load from wind (100 mph gust, exposure B) in example 3.2 is somewhat greater (5,912 lbs).

3.13 References

- American Concrete Institute (ACI). 2011. *Building Code Requirements for Structural Concrete and Commentary*, ACI Standard 318. Farmington Hills, MI: ACI.
- American Society of Civil Engineers (ASCE). 2010. *Minimum Design Loads for Buildings and Other Structures*, ASCE Standard 7-10. Reston, VA: ASCE.
- American Society of Testing and Materials (ASTM). 2005. *Standard Test Method for Performance of Exterior Windows, Curtain Walls, Doors, and Impact Protective Systems Impacted by Missile(s) and Exposed to Cyclic Pressure Differentials* (ASTM E1886-05). West Conshohocken, PA: ASTM.
- . 2009a. *Standard Specification for Asphalt-Saturated Organic Felt Used in Roofing and Waterproofing, Type II* (ASTM D226-09). West Conshohocken, PA: ASTM.
- . 2009B. *STANDARD SPECIFICATION FOR PERFORMANCE OF EXTERIOR WINDOWS, CURTAIN WALLS, DOORS, AND IMPACT PROTECTIVE SYSTEMS IMPACTED BY WINDBORNE DEBRIS IN HURRICANES* (ASTM E1996). WEST CONSHOHOCKEN, PA: ASTM.
- . 2009c. *Standard Specification for Self-Adhering Polymer Modified Bituminous Sheet Materials Used as Steep Roof Underlayment for Ice Dam Protection* (ASTM D1970-09) West Conshohocken, PA: ASTM.
- . 2011. *Standard Test Method for Wind Resistance of Asphalt Shingles* (ASTM D7158-11). West Conshohocken, PA: ASTM.
- . 2012. *Standard Test Method for Laboratory Compaction Characteristics of Soil Using Standard Effort* (D 698-12). West Conshohocken, PA: ASTM.
- Applied Technology Council (ATC). 1995. *A Critical Review of Current Approaches to Earthquake-Resistant Design* (ATC-34). Redwood City, CA: ATC.
- American Wood Council, 2012. *Wood Frame Construction Manual for One- and Two-Family Dwellings* (ANSI/AWC WFCM 2012) Leesburg, VA: AWC.

- Chalk, Philip L., and Ross B. Corotis. 1978. "Probability Models for Design Live Loads," *Journal of the Structural Division* 106 (ST10).
- Chopra, Anil K. 2012. *Dynamics of Structures, Theory and Applications to Earthquake Engineering*, 4th ed. Upper Saddle River, NJ: Prentice-Hall.
- Ellingwood, B., J.G. MacGregor, T.V. Galambos, and C.A. Cornell. 1982. "Probability Based Load Criteria: Load Factors and Load Combinations," *Journal of the Structural Division* 108 (ST5). Reston, VA: American Society of Civil Engineers.
- Federal Emergency Management Agency (FEMA). 2008a. *Design and Construction Guidance for Community Safe Rooms*, FEMA P-361. Washington, DC: FEMA.
- . 2008b. *Taking Shelter From the Storm: Building a Safe Room For Your Home or Small Business*, FEMA P-320. Washington, DC: FEMA.
- . 2009a. *National Earthquake Hazards Reduction Program (NEHRP) Recommended Seismic Provisions for New Buildings and Other Structures*. Washington, DC: FEMA.
- . 2009b. *Quantification of Building Seismic Performance Factors*, FEMA P-695. Washington, DC: FEMA.
- . 2011a. *Coastal Construction Manual FEMA P-55*. Washington, DC: FEMA.
- . 2011b. *Home Builder's Guide to Coastal Construction*, FEMA P-499. Washington, DC: FEMA.
- Fernandez, G., F.J. Masters, and K.R. Gurley. 2010. "Performance of Hurricane Shutters Under Impact by Roof Tiles," *Engineering Structures* 32: 3384–3393.
- Filiatrault et al. 2010. "Experimental Seismic Response of a Full-Scale Light-Frame Wood Building," *Journal of Structural Engineering* 136 (3): 246-254.
- Galambos, T.V. and B. Ellingwood. 1986. "Serviceability Limit States: Deflection," *Journal of Structural Engineering* 112 (1): 67–84.
- Galambos, T.V., B. Ellingwood, J.G. MacGregor, and C.A. Cornell. 1982. "Probability Based Load Criteria: Assessment of Current Design Practice," *Journal of the Structural Division* 108 (5): 959–977.

- Haan et al. 2010. “Tornado-Induced Wind Loads on a Low-Rise Building,” *Journal of Structural Engineering* 136 (1): 106–116.
- Harris, Michael E., Ross B. Corotis, and Carl J. Bova. 1981. “Area-Dependent Processes for Structural Live Loads,” *Journal of the Structural Division* 107 (5): 857–872.
- U.S. Department of Housing and Urban Development (HUD). 1977. *Manual for the Construction of Residential Basements in Non-Coastal Flood Environments*. Prepared for HUD by the NAHB Research Foundation, Rockville, MD.
- . 1994. *Assessment of Damage to Residential Buildings Caused by the Northridge Earthquake*. Prepared for HUD by the NAHB Research Center, Inc., Upper Marlboro, MD.
- . 2011. *Safer, Stronger Homes: Reducing Your Risk During a Natural Disaster*. Prepared for HUD by Newport Partners LLC, Davidsonville, MD, and ARES Consulting, West River, MD.
- International Code Council, Inc. (ICC). 2008. *ICC/NSSA Standard for the Design and Construction of Storm Shelters*, ICC 500. Washington, DC: ICC.
- . 2011. *2012 International Residential Code for One- and Two-Family Dwellings*. Country Club Hills, IL: ICC.
- . 2012. *2012 International Building Code*. Washington, DC: ICC.
- Linell, K.A., and E.F. Lobacz. 1980. *Design and Construction of Foundations in Areas of Deep Seasonal Frost and Permafrost*, Special Report 80-34. Hanover, NH: Cold Regions Research and Engineering Laboratory.
- Masters, F.J., K.R. Gurley, N. Shah*, and G. Fernandez*. 2010. “Vulnerability of Residential Window Glass to Lightweight Windborne Debris.” *Engineering Structures* 32 (4): 911–921.
- Mehta, K.C., J.R. McDonald, J.E. Minor, and A.J. Sanger. 1971. “Response of Structural Systems to the Lubbock Storm; Final Report,” storm research report, Texas Tech University, Lubbock.
- Merritt, Frederick S. 1983. *Standard Handbook for Civil Engineers*, 3rd ed. New York: McGraw-Hill.
- National Climatic Data Center (NCDC). 2013. *Average annual number of tornadoes*. Available at <https://www.ncdc.noaa.gov/climate-information/extreme-events/us-tornado-climatology>

- National Weather Service (NWS). 2013. *Natural Hazard Statistics (1995-2012)*, compiled by the National Climatic Data Center. Available at <http://www.nws.noaa.gov/os/hazstats.shtml> (accessed November 5).
- Peck, R.B., W.E. Hanson, and T.H. Thornburn. 1974. *Foundation Engineering*. New York: John Wiley & Sons.
- Prevatt et al. 2012. Making the case for improved structural design: Tornado outbreaks of 2011. *Leadership and Management in Engineering* 12 (4), 254-270.
- Ramsdell, J.V., J.P. Rishel, U.S. Nuclear Regulatory Commission, and Pacific Northwest Laboratory. 2007. "Tornado Climatology of the Contiguous United States." Washington, DC: U.S. Nuclear Regulatory Commission, Office of Nuclear Regulatory Research, Division of Risk Assessment and Special Projects.
- Rankine, W., 1857. On the Stability of Loose Earth. *Proceedings of the Royal Society of London*, 147:9-27.
- Salzano, C.T., F.J. Masters, and J.D. Katsaros, 2010. Water Penetration Resistance of Residential Window Installation Options for Hurricane-Prone Areas. *Building and Environment* 45 (6): 1373–1388.
- University of Alberta. 1992. *Thin Wall Foundation Testing*. Department of Civil Engineering, University of Alberta.
- United States Army Corps of Engineers (USACE). 2009. *Coastal Engineering Manual*. Vicksburg, MS: USACE.



CHAPTER 4

Design of Foundations

4.1 General

A foundation supports and anchors the superstructure of a building and transfers all loads (including those from flood, wind, or seismic events) imposed on it directly to the ground. Foundations distribute the loads to the earth over an adequate area so that loads do not exceed the bearing capacity of the soil and so that lateral movement or settlement is minimized. In cold climates, the bottom of the foundation must be below the frost line to prevent freeze-thaw damage and frost heave of the footing.

A foundation in residential construction may consist of a footing, wall, slab, pier, pile, or a combination of these elements. This chapter addresses the following foundation types—

- Crawl space.
- Basement.
- Slab-on-grade with stem wall.
- Monolithic slab.
- Piles.
- Piers.
- Alternative methods.

As discussed in chapter 1, the most common residential foundation materials are cast-in-place concrete and concrete masonry (that is, concrete block). Preservative-treated wood, precast concrete, and other materials may also be used. The concrete slab-on-grade is a prevalent foundation type in the South and Southwest; basements are the most common type in the East and Midwest. Crawl spaces are common in the Northwest and Southeast. Pile foundations designed to function after being exposed to scour and erosion are commonly used in coastal flood zones to elevate structures above flood levels. Piles also are used in weak or

expansive soils to reach a stable stratum and on steeply sloped sites. Figure 4.1 depicts different foundation types; a brief description follows.

A *crawl space* is a building foundation that uses a perimeter foundation wall to create an underfloor space that is not habitable; the interior crawl space elevation may or may not be below the exterior finish grade. In mapped flood plains, a crawl space that has the interior grade below the exterior grade on all sides is considered a basement. A *basement* typically is defined as a portion of a building that is partly or completely below the exterior grade and that may be used as habitable space, as storage space, or for parking. The primary difference between a basement and a crawl space is height (basements usually are taller). The floors of basements usually are finished, and the interiors frequently are finished. The wall height is sometimes determined by the depth of the footing required for frost protection.

A *slab-on-grade with an independent stem wall* is a concrete floor supported by the soil independently of the rest of the building. The stem wall supports the building loads and in turn is supported directly by the soil or a footing. A *monolithic* or *thickened-edge slab* is a ground-supported slab-on-grade with an integral footing (that is, a thickened edge); it is normally used in warmer regions that have little or no frost depth but is also used in colder climates when adequate frost protection is provided (see section 4.7).

When necessary, *piles* are used to transmit the load to a deeper soil stratum with a higher bearing capacity to prevent failure from undercutting of the foundation by scour from flood water flow at high velocities and to elevate the building above required flood elevations. Piles also are used to isolate the structure from expansive soil movements.

Pier and beam foundations can provide an economical alternative to crawl space perimeter wall construction. A common practice is to use a brick curtain wall between piers for appearance and bracing.

The design procedures and information in this chapter cover the following topics.

- Foundation materials and properties.
- Soil-bearing capacity and footing size.
- Concrete or gravel footings.
- Concrete and masonry foundation walls.
- Preservative-treated wood walls.
- Insulating concrete foundations.
- Concrete slabs on grade.
- Pile foundations.
- Frost protection.

Concrete design procedures generally follow the strength design method contained in the American Concrete Institute's ACI 318 (ACI, 2011) although certain aspects of the procedures may be considered conservative relative to conventional residential foundation applications. For this reason, this guide provides supplemental design guidance when practical and technically justified. ACI 332 (ACI, 2010), which contains design provisions and guidance specific to residential construction, is

referenced in the International Residential Code (IRC) as an alternative to the conventional foundation requirements of the code or the design procedures of ACI 318. Masonry design procedures follow the allowable stress design (ASD) method of The Masonry Society's TMS 402 (TMS, 2011). Wood design procedures are used to design the connections between the foundation system and the structure above and follow the ASD method for wood construction (see chapter 7 for connection design information). In addition, the designer is referred to the applicable design standards for symbol definitions and additional guidance because the intent of this chapter is to provide supplemental instruction in the efficient design of residential foundations.

To maintain consistency, this guide uses the load and resistance factor design (LRFD) load combinations that were used in chapter 3, which are also those specified in the American Society of Civil Engineers' ASCE 7. There may be some minor variations in those required in ACI 318 for strength design of concrete. The purpose of this guide is to provide designs that are at least consistent with current residential building code and construction practice. With respect to the design of concrete in residential foundations, the guide seeks to provide reasonable safety margins that meet or exceed the minimums required for other, more crucial requirements of a home—namely, the safety of lives. The designer is responsible for ensuring that the design meets the building code requirements and will be approved by the building official.

FIGURE 4.1

Types of Foundations

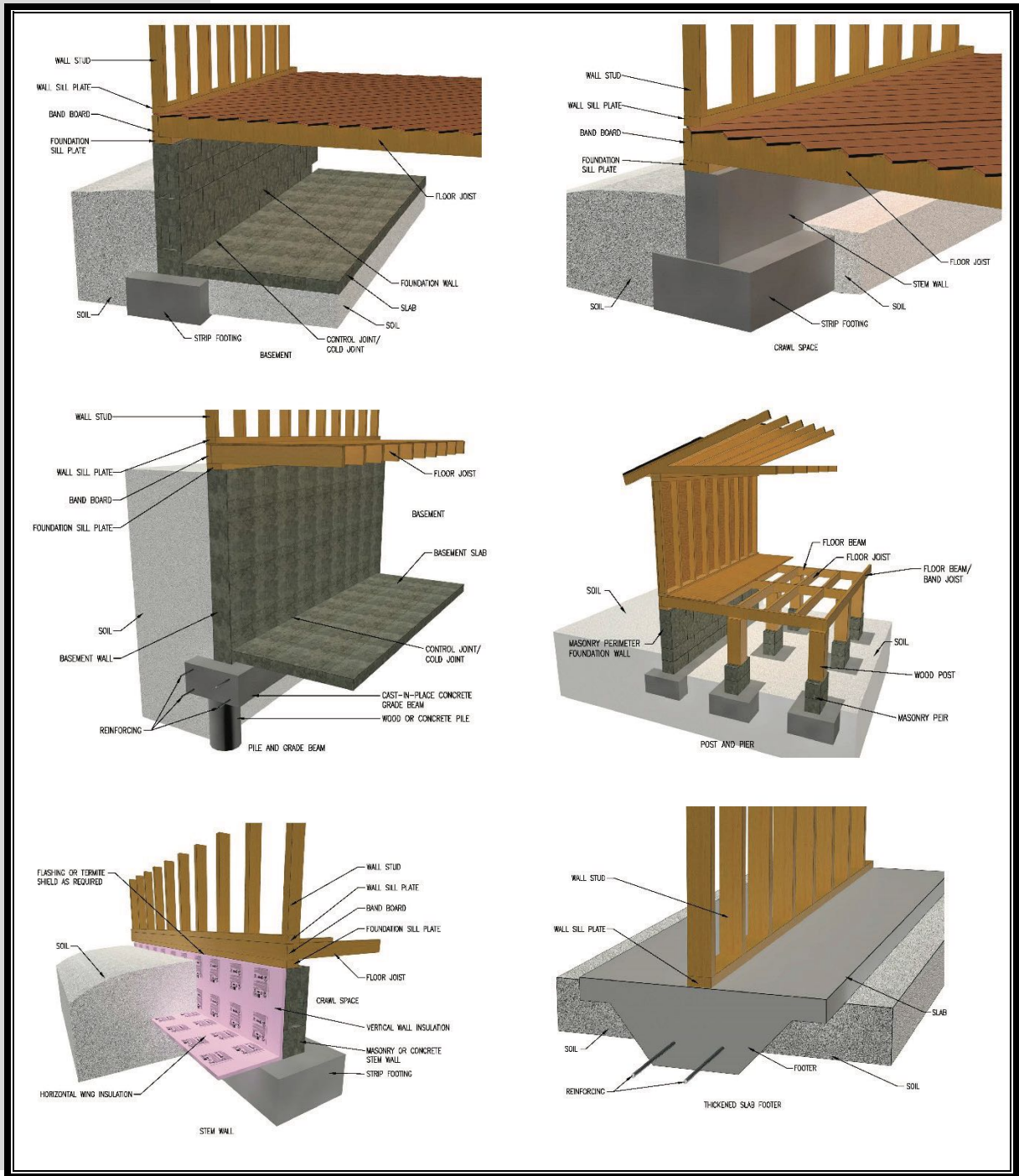

4.2 Material Properties

A residential designer using concrete and masonry materials must have a basic understanding of such materials, including variations in the materials' composition and structural properties. In addition, a designer must take into consideration soils, which are also considered a foundation material (Section 4.3 provides information on soil bearing). A brief discussion of the properties of concrete and masonry follows.

4.2.1 Concrete

The concrete compressive strength (f_c') used in residential construction is typically either 2,500 or 3,000 pounds per square inch (psi), although other values may be specified. For example, 4,000 psi concrete may be used for improved weathering resistance in particularly severe climates or unusual applications. The concrete compressive strength may be verified in accordance with the American Society for Testing and Materials' ASTM C39 (ASTM, 2012c). Given that the rate of increase in concrete strength diminishes with time, the specified compressive strength usually is associated with the strength attained after 28 days of curing time, when the concrete attains about 85 percent of its fully cured compressive strength.

Concrete is a mixture of cement, water, and sand, gravel, crushed rock, or other aggregates. Sometimes one or more admixtures are added to change certain characteristics of the concrete, such as workability, durability, and time of hardening. The proportions of the components determine the concrete mix's compressive strength and durability.

Type

Portland cement is classified into several types, in accordance with ASTM C150 (ASTM, 2012b). Residential foundation walls typically are constructed with *Type I* cement, which is a general-purpose Portland cement used for the vast majority of construction projects. Other types of cement are appropriate in accommodating conditions related to heat of hydration in massive pours and sulfate resistance. In some regions, sulfates in soils have caused durability problems with concrete. The designer should check into local conditions and practices.

Weight

The weight of concrete varies depending on the type of aggregates used in the concrete mix. Concrete typically is classified as lightweight or normal weight. The density of unreinforced normal weight concrete ranges between 144 and 156 pounds per cubic foot (pcf) and typically is assumed to be 150 pcf. Residential foundations usually are constructed with normal weight concrete.

Slump

Slump is the measure of concrete consistency; the higher the slump, the wetter the concrete and the easier it flows. Slump is measured in accordance with ASTM C143 (ASTM, 2012d) by inverting a standard 12-inch-high metal cone, filling it with concrete, and then removing the cone; the amount the concrete that settles in units of inches is the slump. Most foundations, slabs, and walls consolidated by hand methods have a slump between 4 and 6 inches. One problem associated with a high-slump concrete is segregation of the aggregate, which leads to cracking and scaling. Therefore, a slump of greater than 6 inches should be avoided. Adding water lowers the strength while improving workability, so the total amount of water in the concrete should be carefully monitored and controlled. Admixtures used during extremely cold or hot weather placement (or for other reasons) may change the slump.

Weather Resistance

Concrete is largely weather resistant. When concrete may be subjected to freezing and thawing during construction, however, or when concrete is located in regions prone to extended periods of freezing, additional measures must be taken. Those requirements can be found in the IRC (ICC, 2012), and include air entrainment and increased minimum compressive strength requirements.

Admixtures

Admixtures are materials added to the concrete mix to improve workability and durability and to retard or accelerate curing. Some of the most common admixtures are described below.

- *Water reducers* improve the workability of concrete without reducing its strength.
- *Retarders* are used in hot weather to allow more time for placing and finishing concrete. Retarders may also reduce the early strength of concrete.
- *Accelerators* reduce the setting time, allowing less time for placing and finishing concrete. Accelerators may also increase the early strength of concrete.
- *Air entrainers* are used for concrete that will be exposed to freeze-thaw conditions and deicing salts. Less water is needed and segregation of aggregate is reduced when air entrainers are added.

Reinforcement

Concrete has high compressive strength but low tensile strength; therefore, reinforcing steel often is embedded in the concrete to provide additional tensile strength and ductility. In the rare event that the capacity is exceeded, the reinforcing steel begins to yield, thereby preventing an abrupt failure that may otherwise occur with plain, unreinforced concrete. For this reason, a larger safety margin is used in the design of plain concrete construction than in reinforced concrete construction.

Steel reinforcement is available in grade 40 or grade 60; the grade number refers to the minimum tensile yield strength (f_y) of the steel (i.e., grade 40 is a minimum 40 thousand pounds per square inch [ksi] steel and grade 60 is a minimum 60 ksi steel). Either grade may be used for residential construction; however, most steel reinforcement in the U.S. market today is grade 60. The concrete mix, or slump, must be adjusted by adding the appropriate amount of water to allow the concrete to flow easily around the reinforcement bars, particularly when the bars are closely spaced or are crowded at points of overlap. Close rebar spacing rarely is required in residential construction, however, and should be avoided in design if at all possible.

The most common steel reinforcement or rebar sizes in residential construction are No. 3, No. 4, and No. 5, which correspond to diameters of 3/8 inch, 1/2 inch, and 5/8 inch, respectively. The bar designations indicate the bar size in 1/8-inch increments. These three sizes of rebar are easily manipulated at the jobsite by using manual bending and cutting devices. Table 4.1 shows useful relationships between the rebar number, diameter, and cross-sectional area for reinforced concrete and masonry design.

Fiber reinforcement is being used in some concrete slab installation. The fiber could be steel, natural, or synthetic. It helps (1) improve resistance to freeze-thaw, (2) increase resistance to some spalling of the surface, (3) control cracking, and (4) improve the concrete's shatter resistance. Fibers generally do not increase the structural strength of the concrete slab and do not replace normal reinforcing bars used for tensile strength.

TABLE 4.1 ***Rebar Size, Diameter, and Cross-Sectional Areas***

Size	Diameter (inches)	Area (square inches)
No. 3	3/8	0.11
No. 4	1/2	0.20
No. 5	5/8	0.31
No. 6	3/4	0.44
No. 7	7/8	0.60
No. 8	1	0.79

4.2.2 Concrete Masonry Units

Concrete masonry units (CMUs), commonly referred to as concrete blocks, are composed of Portland cement, aggregate, and water. In some situations, CMUs may also include admixtures. Low-slump concrete is molded and cured to produce strong blocks or units. Residential foundation walls typically are constructed with units 7 5/8 inches (nominal 8 inches) high by 15 5/8 inches (nominal 16 inches) long, providing a 3/8-inch allowance for the width of mortar joints. Nominal 8- and 12-inch-thick CMUs are readily available for use in residential construction.

Type

ASTM C90 (ASTM, 2013) requires that the minimum average design strength (f'_m) of standard CMUs be 1,900 psi, with no individual unit having a compressive strength of less than 1,700 psi. Higher strengths also may be specified if required by design. The ASTM classification includes two types. Type II is a non-moisture-controlled unit and is the type typically used for residential foundation walls.

Weight

CMUs are available with different densities by altering the type(s) of aggregate used in their manufacture. CMUs typically are referred to as lightweight, medium weight, or normal weight, with respective unit weights or densities of less than 105 pcf, between 105 and 125 pcf, and more than 125 pcf. Residential foundation walls typically are constructed with low- to medium-weight units because of the low compressive strength required. Lower density units are generally more porous, however, and must be properly protected to resist moisture intrusion. A common practice in residential basement foundation wall construction is to provide a cement-based parge coating and a brush- or spray-applied bituminous coating on the belowground portions of the wall. Section R406 in the IRC provides the prescriptive requirements for parging and damp-proofing or waterproofing foundation walls that retain earth and enclose interior spaces. The parge coating is not required for concrete foundation wall construction.

Hollow or Solid

CMUs are classified as hollow or solid in accordance with ASTM C90. The net concrete cross-sectional area of most CMUs ranges from 50 to 70 percent, depending on unit width, face-shell and web thicknesses, and core configuration. *Hollow* units are defined as those in which the net concrete cross-sectional area is less than 75 percent of the gross cross-sectional area. *Solid* units are not necessarily solid but are defined as those in which the net concrete cross-sectional area is 75 percent of the gross cross-sectional area or greater.

Mortar

Masonry mortar is used to join CMUs into a structural wall; it also retards air and moisture infiltration. The most common way to lay block is in a running bond pattern, in which the vertical head joints between blocks are offset by half the block length from one course to the next. Mortar is composed of water, cement, lime, and clean, well-graded sand, and water and is typically classified into *types M, S, N, O,* and *K*, in accordance with ASTM C270 (ASTM, 2012a). Residential foundation walls typically are constructed with *type M* or *type S* mortar, both of which are generally recommended for load-bearing interior and exterior walls, including above- and below-grade applications.

Grout

Grout is a slurry consisting of cementitious material, aggregate, and water. When needed, grout commonly is placed in the hollow cores of CMUs to provide a wall with added strength. In reinforced load-bearing masonry wall construction, grout is usually placed only in those hollow cores containing steel reinforcement. The grout bonds the masonry units and steel so that they act as a composite unit to resist imposed loads. Grout may also be used in unreinforced concrete masonry walls for added strength. The IRC requires grouted cells at foundation sill and sole plate anchor bolt locations, regardless of whether the masonry wall is otherwise reinforced.

4.3 Soil-Bearing Capacity and Footing Size

Soil-bearing investigations rarely are required for residential construction except when a history of local problems provides evidence of known risks (for example, organic deposits, landfills, expansive soils, and seismic risk). Soil-bearing tests on stronger-than-average soils can, however, justify using smaller footings or eliminating footings entirely if the foundation wall provides sufficient bearing surface. Table 4.2 provides a conservative relationship between soil type and load-bearing value. A similar table is published in the building codes (table R401.4.1 in the IRC). These presumptive soil-bearing values, however, should be used only when the building codes do not require geotechnical investigation reports (section R401.4, IRC).

TABLE 4.2 *Presumptive Soil-Bearing Values by Soil Description*

Presumptive Load-Bearing Value (psf)	Soil Description
1,500	Clay, sandy clay, silty clay, clayey silt, silt, and sandy silt
2,000	Sand, silty sand, clayey sand, silty gravel, and clayey gravel
3,000	Gravel and sandy gravel
4,000	Sedimentary and foliated rock
12,000	Crystalline bedrock

psf = pounds per square foot.

Source: ICC (2012).

When a soil-bearing investigation is desired to determine more accurate and economical footing requirements, the designer commonly turns to ASTM D1586, *Standard Penetration Test (SPT) and Split-Barrel Sampling of Soils* (ASTM, 2011). This test relies on a 2-inch-diameter device driven into the ground with a 140-pound hammer dropped from a distance of 30 inches. The number of hammer drops or blows needed to create a 1-foot penetration (blow count) yields values that can be roughly correlated to soil-bearing values, as shown in Table 4.3. The instrumentation and cost of conducting the SPT usually are not warranted for typical residential applications. Nonetheless, the SPT method provides information on deeper soil strata and thus can offer valuable guidance for foundation design and building location, particularly when subsurface conditions threaten to be problematic. The values in Table 4.3 are associated with the blow count from the SPT method. Many engineers can provide reasonable estimates of soil bearing by using smaller penetrometers at lower cost, although such devices and methods may require an independent calibration to determine presumptive soil-bearing values and may not be able to detect deep subsurface problems. Calibrations may be provided by the manufacturer or, alternatively, developed by the engineer.

In addition to ASTM D1586, the Dynamic Cone Penetrometer (DCP) test (Burnham and Johnson, 1993), has gained widespread use as a more economical alternative with equivalent accuracy. In this handheld test, a metal cone is driven into the ground by repeatedly striking it with a 17.6-pound (8-kilogram) weight, dropped from a distance of 2.26 feet (575 millimeters). Penetration of the cone is measured after each blow; the blow count per 1 3/4-inch penetration is approximately equivalent to the SPT blow count provided in table 4.3.

The designer should exercise judgment when selecting the final design value and be prepared to make adjustments (increases or decreases) in interpreting and applying the results to a specific design. The values in tables 4.2 and 4.3 generally are associated with a safety factor of 3 (Naval Facilities Engineering Command, 1986) and are considered appropriate for noncontinuous or independent spread footings supporting columns or piers (that is, point loads). Use of a safety factor could be

considered for smaller structures with continuous spread footings, such as houses, or structures for which ultimate (LRFD) values are used for design loads. The presumptive values in Table 4.3—or as modified as described previously—are intended to be used with the ASD load combinations in chapter 3. If LRFD (strength) design load combinations are used, then the presumptive values should be additionally adjusted (that is, divided by the maximum load factor in the load combination considered, usually a factor of 1.6 for live or snow loads).

Table 4.3 *Presumptive Soil-Bearing Values (psf) Based on Standard Penetrometer Blow Count*

In Situ Consistency, N ¹		Loose ² (5 to 10 blows per foot)	Firm (10 to 25 blows per foot)	Compact (25 to 50 blows per foot)
Noncohesive Soils	Gravel	4,000 (10)	8,000 (25)	11,000 (50)
	Sand	2,500 (6)	5,000 (20)	6,000 (35)
	Fine sand	1,000 (5)	3,000 (12)	5,000 (30)
	Silt	500 (5)	2,000 (15)	4,000 (35)
In Situ Consistency, N ¹ :		Soft ³ (3 to 5 blows per foot)	Medium (about 10 blows per foot)	Stiff (more than 20 blows per foot)
Cohesive Soils	Clay, sand, gravel mixtures	2,000 (3)	5,000 (10)	8,000 (20)
	Sandy or silty clay	1,000 (4)	3,000 (8)	6,000 (20)
	Clay	500 (5)	2,000 (10)	4,000 (25)

Source: Naval Facilities Engineering Command, 1986.

psf = pounds per square foot.

¹N denotes the standard penetrometer blow count in blows per foot, in accordance with ASTM D1586; shown in parentheses.

²Compaction should be considered in these conditions, particularly when the blow count is five blows per foot or less.

³Pile and grade beam foundations should be considered in these conditions, particularly when the blow count is five blows per foot or less.

The required width or area of a spread footing is determined by dividing the building load on the footing by the soil-bearing capacity from table 4.2 or table 4.3, as shown below. Building design loads, including dead and live loads, should be determined in accordance with chapter 3 by using ASD load combinations.

$$Area_{\text{independent spread footing}} = \frac{\text{Load in lbs}}{\text{Soil – bearing capacity in psf}}$$

$$Width_{\text{continuous footing}} = \frac{\text{Load, lb per linear foot (plf)}}{\text{Soil – bearing capacity in psf}}$$

4.4 Footings

The objectives of footing design are—

- To provide a level surface for construction of the foundation wall.
- To provide adequate transfer and distribution of building loads to the underlying soil.
- To provide adequate strength, in addition to the foundation wall, to prevent differential settlement of the building in weak or uncertain soil conditions by bridging those poor soil conditions.
- To place the building foundation at a sufficient depth to avoid frost heave or thaw weakening in frost-susceptible soils and to avoid organic surface soil layers.
- To provide adequate anchorage or mass (when needed in addition to the foundation wall) to resist potential uplift, sliding, and overturning forces resulting from high winds or severe seismic events.

This section presents design methods for concrete and gravel footings. The designer must first establish the required footing width in accordance with section 4.3. Further, if soil conditions are stable or the foundation wall can adequately resist potential differential settlement, the footing may be completely eliminated.

By far, the most common footing in residential construction is a continuous concrete spread footing; however, concrete and gravel footings are both recognized in prescriptive footing size tables in residential building codes for most typical conditions (ICC, 2012). In contrast, special conditions give rise to engineering concerns that must be addressed to ensure the adequacy of any foundation design. Special conditions include—

- Steeply sloped sites requiring a stepped footing.
- High wind conditions.
- Inland or coastal flooding conditions.
- High-hazard seismic conditions.
- Poor soil conditions.

4.4.1 Simple Gravel and Concrete Footing Design

Building codes for residential construction contain tables that prescribe minimum footing widths for plain concrete footings (ICC, 2012). Alternatively, footing widths may be determined in accordance with section 4.3, based on a site's particular loading condition and presumptive soil-bearing capacity. The following are general rules of thumb for determining the thickness of plain concrete footings for residential structures, once the required bearing width has been calculated.

- The minimum footing thickness should not be less than the distance the footing extends outward from the edge of the foundation wall or 6 inches, whichever is greater.
- The footing width should project a minimum of 2 inches from both faces of the wall (to allow for a minimum construction tolerance) but not greater than the footing thickness.

These rules of thumb generally result in a footing design that differs somewhat from the plain concrete design provisions of chapter 22 of ACI 318. Footing widths generally follow the width increments of standard excavation equipment (in other words, a backhoe bucket size of 12, 16, or 24 inches). Although longitudinal steel reinforcement is not always required for residential-scale structures in typical soil conditions, the designer should consider adding some (two No. 4 or No. 5 bars is common) to avoid possible footing cracking where soil consolidation or a loss of soil-bearing capacity can occur. For situations in which the rules of thumb or prescriptive code tables do not apply or in which a more economical solution is possible, a more detailed footing analysis may be considered (see section 4.4.2). Example 4.1 in section 4.9 illustrates a plain concrete footing design in accordance with the simple method described herein.

Much like a concrete footing, a gravel footing may be used to distribute foundation loads to a sufficient soil-bearing surface area. A gravel footing provides a continuous path for water or moisture and thus must be drained in accordance with the foundation drainage provisions of the IRC. Gravel footings are constructed of crushed stone or gravel that is consolidated by tamping or vibrating. Pea gravel, which is naturally consolidated, does not require compaction and can be screeded to a smooth, level surface, much like concrete. Although typically associated with pressure-treated wood foundations (refer to section 4.5.3), a gravel footing can support cast-in-place or precast concrete foundation walls.

The size of a gravel footing usually is based on a 30- to 45-degree angle of repose for distributing loads; therefore, as with plain concrete footings, the required depth and width of the gravel footing depends on the width of the foundation wall, the foundation load, and soil-bearing values. Following a rule of thumb similar to that for a concrete footing, the gravel footing thickness should be

no less than 1.5 times its extension beyond the edge of the foundation wall or, in the case of a pressure-treated wood foundation, the mud sill. Just as with a concrete footing, the thickness of a gravel footing may be considered in meeting the required frost depth. In soils that are not naturally well drained, provision should be made to adequately drain a gravel footing.

4.4.2 Concrete Footing Design

For many residential footing designs, prescriptive and conventional residential footing requirements found in residential building codes and construction guides are adequate, if not conservative. Concrete design for residential construction is covered in ACI 332 *Residential Code Requirements for Structural Concrete* (ACI, 2010). To improve performance and economy or to address peculiar conditions, however, a footing may need to be specially designed. Many floor plans in today's residential buildings are partially open and frequently create nonuniform loading conditions on load-bearing walls and footings. These nonuniform load conditions must be considered in the design of footings, and reliance on strictly prescriptive methods of design is not always a sound design decision.

A footing is designed to resist the upward-acting pressure created by the soil beneath the footing; that pressure tends to make the footing bend upward at its edges. According to ACI 318, the three modes of failure considered in reinforced concrete footing design are one-way shear, two-way shear, and flexure (see figure 4.2). Bearing (crushing) is also a possible failure mode but is rarely applicable to residential loading conditions. To simplify calculations for the three failure modes, the following discussion explains the relation of the failure modes to the design of plain and reinforced concrete footings (Refer to ACI 318 for additional commentary and guidance). The design equations used later in this section are based on ACI 318 and principles of engineering mechanics, as described herein. Moreover, the approach is based on the assumption of uniform soil-bearing pressure on the bottom of the footing; therefore, walls and columns should be supported as close as possible to the center of the footings.

One-Way (Beam) Shear

When a footing fails due to *one-way (beam) shear*, the failure occurs at an angle approximately 45 degrees to the wall, as shown in figure 4.2. For plain concrete footings, the soil-bearing pressure has a negligible effect on the diagonal shear tension for distance t from the wall edge toward the footing edge; for reinforced concrete footings, the distance used is d , which equals the depth to the footing rebar (see figure 4.2). As a result, one-way shear is checked by assuming that beam action occurs at a critical failure plane extending across the footing width, as shown in figure 4.2. One-way shear must be considered in similar fashion in both continuous wall and rectangular footings; however, for ease of calculation, continuous wall footing design typically is based on one lineal foot of wall or footing.

Two-Way (Punching) Shear

When a footing fails by *two-way (punching) shear*, the failure occurs at an angle approximately 30 degrees to the column or pier, as shown in figure 4.2. Punching shear rarely is a concern in the design of continuous wall footings; thus, punching shear is usually checked only in the case of rectangular or circular footings with a heavily loaded pier or column that creates a large concentrated load on a relatively small area of the footing. For plain concrete footings, the soil-bearing pressure has a negligible effect on the diagonal shear tension at distance $t/2$ from the face of a column toward the footing edges; for reinforced concrete footings, the distance from the face of the column is $d/2$ (see figure 4.2). The shear force, therefore, consists of the net upward-acting pressure on the area of the footing outside the punched-out area (hatched area in figure 4.2). For square, circular, or rectangular footings, shear is checked at the critical section that extends in a plane around a concrete, masonry, wood, or steel column or pier that forms the perimeter b_o of the area previously described.

FIGURE 4.2 *Critical Failure Planes in Continuous or Square Concrete Spread Footings*

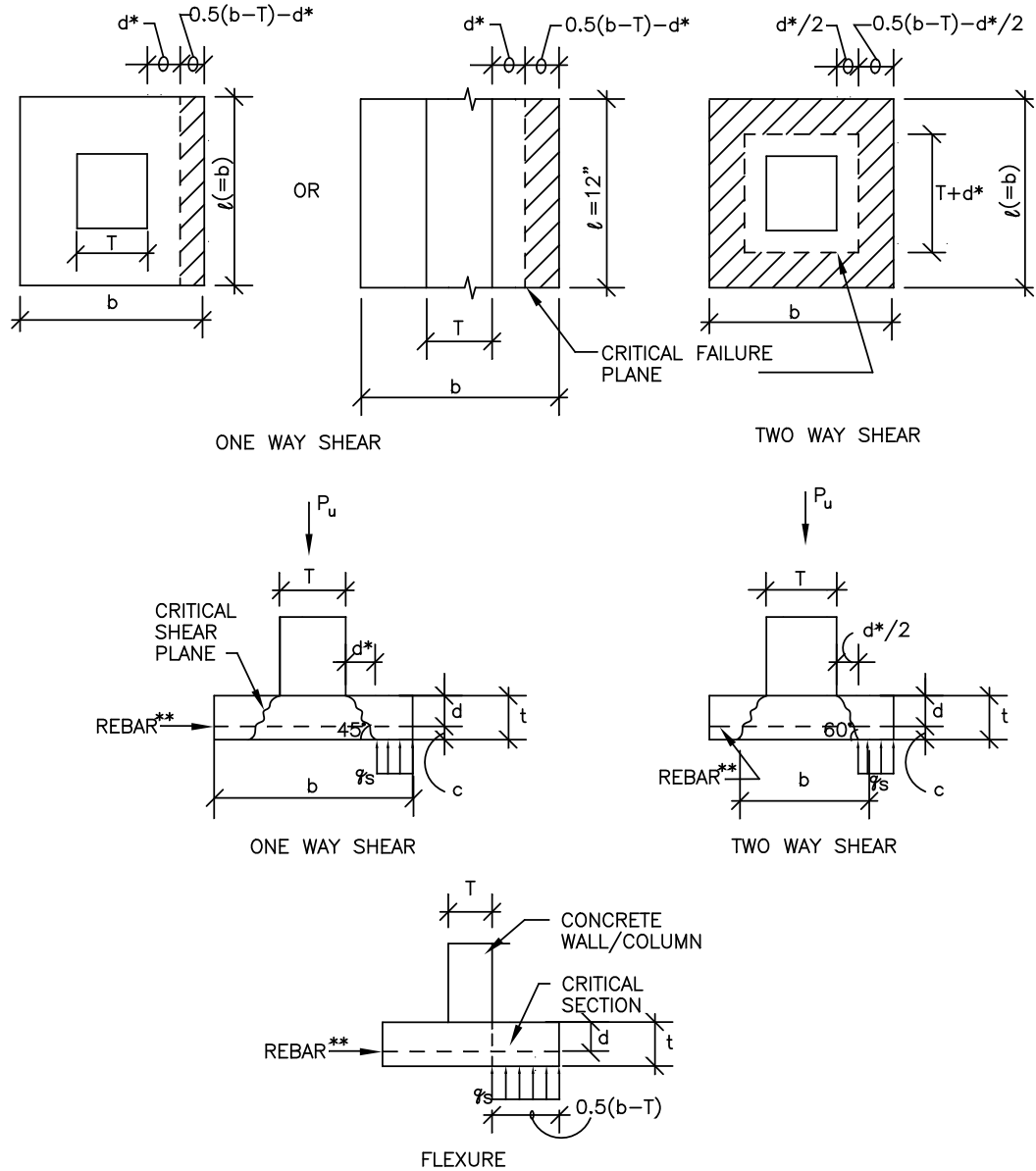

- NOTES:** * SUBSTITUTE t FOR d AS REQUIRED FOR PLAIN CONCRETE FOOTING DESIGN
 ** REBAR IS REQUIRED ONLY IN REINFORCED CONCRETE FOOTING DESIGN AND IS SHOWN HERE FOR THAT PURPOSE ONLY. IN REINFORCED SQUARE FOOTINGS, THE REBAR MUST BE PLACED IN TWO DIRECTIONS.

Flexure (Bending)

The maximum moment in a footing deformed by the upward-acting soil pressures would logically occur in the middle of the footing; however, the rigidity of the wall or column above resists some of the upward-acting forces and affects the location of maximum moment. As a result, the critical flexure plane for footings supporting a rigid wall or column is assumed to be located at the face of the wall or column. Flexure in a concrete footing is checked by computing the moment created by the soil-bearing forces acting over the cantilevered area of the footing that extends from the critical flexure plane to the edge of the footing (hatched area in figure 4.2). The approach for masonry walls in ACI 318 differs slightly in that the failure plane is assumed to be located one-fourth of the way under a masonry wall or column, creating a slightly longer cantilever. For the purpose of this guide, the difference is considered unnecessary.

Bearing Strength

Conditions in which concrete bearing or compressive strength is a concern are uncommon in typical residential construction; therefore, a design check usually can be dismissed as “OK by inspection.” In rare and peculiar instances in which bearing compressive forces on the concrete are extreme and approach or exceed the specified concrete compressive strength, the designer should consult ACI 318 for appropriate guidance.

4.4.2.1 Plain Concrete Footing Design

In this section, the design of plain concrete footings is presented by using the concepts related to shear and bending covered in the previous section (refer to example 4.1 in section 4.9 for a design example of a plain concrete footing).

Shear

In the equations that follow for one- and two-way shear, the dimensions are in accordance with figure 4.2; units of inches should be used. ACI 318 requires that the overall thickness (t) be taken as 2 inches less than the actual thickness to compensate for uneven trench conditions. The following equations are specifically tailored for footings supporting walls or square columns because such footings are common in residential construction. The equations may be generalized for use with other conditions (for example, rectangular footings and rectangular columns, round footings) by following the same principles. In addition, the terms $4/3 \sqrt{f'_c}$ and $4 \sqrt{f'_c}$ are in units of psi and represent lower bound estimates of the ultimate shear stress capacity of unreinforced concrete.

One-Way (Beam) Shear

$\phi V_c \geq V_u$	basic design check for shear
$V_u = (q_s)(0.5(b - T) - t)\ell$	factored shear load (lb)
$q_s = \frac{P_u}{b\ell}$	uniform soil bearing pressure (psi) due to factored foundation load P_u (lb)
$\phi V_c = \phi \frac{4}{3} \sqrt{f'_c} b_o t$	factored shear capacity (lb)
$\phi = 0.65$	resistance factor

Two-Way (Punching) Shear

$\phi V_c \geq V_u$	basic design check for shear
$V_u = (q_s)(b\ell - (T + t)^2)$	shear load (lb) due to factored load P_u (lb)
$q_s = \frac{P_u}{b\ell}$	uniform soil bearing pressure (psi) due to factored foundation load P_u (lb)
$\phi V_c = \phi 4 \sqrt{f'_c} b_o t$	factored shear capacity (lb)
$b_o = 4(T + t)$	perimeter of critical failure plane around a square column or pier
$\phi = 0.65$	resistance factor

Flexure

For a plain concrete footing, flexure (bending) is checked by using the equations that follow for footings that support walls or square columns (see figure 4.2). The dimensions in the equations are in accordance with figure 4.2 and use units of inches. The term $5\sqrt{f'_c}$ is in psi and represents a lower bound estimate of the ultimate tensile (rupture) stress of unreinforced concrete in bending.

$\phi M_n \geq M_u$	basic design check for bending
$M_u = \frac{1}{8} q_s \ell (b - T)^2$	factored moment (in-lb) due to soil pressure q_s (psi) acting on cantilevered portion of footing
$q_s = \frac{P_u}{b\ell}$	uniform soil bearing pressure (psi) due to factored load P_u (lb)
$\phi M_n = \phi 5 \sqrt{f'_c} S$	factored moment capacity (in-lb) for plain concrete
$S = \frac{1}{6} \ell t^2$	section modulus (in ³) for footing
$\phi = 0.65$	resistance factor for plain concrete in bending

4.4.2.2 Reinforced Concrete Footing Design

For situations in residential construction in which a plain concrete footing may not be practical or in which reducing the footing thickness is more economical, steel reinforcement should be considered. A reinforced concrete footing is designed similar to a plain concrete footing; however, the concrete depth d to the reinforcing bar is used to check shear instead of the entire footing thickness t . The depth of the rebar is equal to the thickness of the footing minus the diameter of the rebar d_b and the concrete cover c . In addition, the moment capacity is determined differently due to the presence of the reinforcement, which resists the tension stresses induced by the bending moment. Finally, a higher resistance factor reflects the more consistent bending strength of reinforced concrete compared to unreinforced concrete.

As specified by ACI 318, a minimum of 3 inches of concrete cover over steel reinforcement is required when concrete is in contact with soil. In addition, ACI 318 does not permit a depth d less than 6 inches for reinforced footings supported by soil. The designer may relax these limits, provided that the strength analysis demonstrates adequate capacity; however, a reinforced footing thickness of significantly less than 6 inches may be considered impractical, even though it may calculate acceptably. One exception may be found where a nominal 4-inch-thick slab is reinforced to serve as an integral footing for an interior load-bearing wall (which is not intended to transmit uplift forces from a shear wall overturning restraint anchorage in high-hazard wind or seismic regions). Further, the concrete cover should not be less than 2 inches for residential applications, although this recommendation may be somewhat conservative for interior footings that are generally less exposed to ground moisture and other corrosive agents. Example 4.2 of section 4.9 illustrates reinforced concrete footing design. The placement of steel to comply with concrete cover requirements may also significantly reduce the depth of steel, thus reducing flexural capacity of the concrete element; the designer must consider this reduced depth of steel.

Shear

In the following equations for one- and two-way shear, the dimensions are in accordance with figure 4.2; units of inches should be used. Shear reinforcement (that is, stirrups) is usually considered impractical for residential footing construction; therefore, the concrete is designed to withstand the shear stress, as expressed in the equations. The equations are specifically tailored for footings supporting walls or square columns because such footings are common in residential construction. The equations may be generalized for use with other conditions (rectangular footings and rectangular columns, round footings, and so on) by following the same principles. In addition, the terms $2\sqrt{f'_c}$ and $4\sqrt{f'_c}$ are in units of psi and represent lower bound estimates of the ultimate shear stress capacity of reinforced concrete.

ACI 318•11.12,15.5

One-Way (Beam) Shear

$$\phi V_c \geq V_u \quad \text{basic design check for shear}$$

$$V_u = (q_s)(0.5(b-T)-d)\ell \quad \text{shear load (lb) due to uniform soil-bearing pressure, } q_s \text{ (psi)}$$

$$q_s = \frac{P_u}{b\ell} \quad \text{uniform solid-bearing pressure (psi) due to factored foundation load } P_u \text{ (lb)}$$

$$\phi V_c = \phi 2\sqrt{f'_c} \ell d \quad \text{factored shear capacity (lb)}$$

$$d = t - c - 0.5d_b \quad \text{depth of reinforcement}$$

$$\phi = 0.85 \quad \text{resistance factor for reinforced concrete in shear}$$

Two-Way (Punching) Shear

$$\phi V_c \geq V_u \quad \text{basic design check for shear}$$

$$V_u = \left(\frac{P_u}{b\ell}\right)(b\ell - (T+d)^2) \quad \text{shear load (lb) due to factored load } P_u \text{ (lb)}$$

$$\phi V_c = \phi 4\sqrt{f'_c} b_o d \quad \text{factored shear capacity (lb)}$$

$$b_o = 4(T+d) \quad \text{perimeter of punching shear failure plane around a square column or pier}$$

$$\phi = 0.85 \quad \text{resistance factor for reinforced concrete in shear}$$

Flexure

The flexure equations that follow pertain specifically to reinforced concrete footings that support walls or square columns. The equations may be generalized for use with other conditions (rectangular footings and rectangular columns, round footings, and so on) by following the same principles. The alternative equation for nominal moment strength M_n is derived from force and moment equilibrium principles by using the provisions of ACI 318. Most designers are familiar with the alternative equation that uses the reinforcement ratio ρ and the nominal strength coefficient of resistance R_n . The coefficient is derived from the design check that ensures that the factored moment (due to factored loads) M_u is less than the factored nominal moment strength ϕM_n of the reinforced concrete. To aid the designer in short-cutting these calculations, design manuals provide design tables that correlate the nominal strength coefficient of resistance R_n to the reinforcement ratio ρ for a specific concrete compressive strength and steel yield strength.

ACI 318•15.4

$\phi M_n \geq M_u$	basic design check for bending
$M_u = \frac{1}{8} q_s \ell (b - T)^2$	factored moment (in-lb) due to soil pressure q (psi) acting on cantilevered portion of the footing _s
$\phi M_n = \phi A_s f_y \left(d - \frac{a}{2} \right)$	factored nominal moment capacity (in-lb)
$a = \frac{A_s f_y}{0.85 f'_c \ell}$	(l is substituted for the ACI 318 symbol b for the concrete beam width and is consistent with the footing dimensioning in figure 4.2)
$\phi = 0.9$	resistance factor for reinforced concrete in bending
Alternate method to determine M_n	
$\phi M_n = \phi \rho b d f_y \left(d - \frac{0.5 \rho d f_y}{0.85 f'_c} \right)$	
$\rho = \left(\frac{0.85 f'_c}{f_y} \right) \left(\ell - \sqrt{\frac{2 R_n}{0.85 f'_c}} \right)$	reinforcement ratio determined by use of R_n nominal strength “coefficient of resistance
$R_n = \frac{M_u}{\phi \ell d^2}$	l is substituted for the ACI 318 symbol b for the concrete beam width and is consistent with the footing dimensioning in figure 4.2) defines reinforcement ratio ρ
$A_s = \rho \ell d$	(l is substituted for the ACI 318 symbol b for the concrete beam width and is consistent with the footing dimensioning in figure 4.2)

Minimum Reinforcement

Because of concerns with shrinkage and temperature cracking, ACI 318 requires a minimum amount of steel reinforcement. For grade 60 reinforcing steel, the minimum area of steel used for shrinkage and temperature cracking is 0.0018 square inches. ACI 318 requirements on the minimum area of steel for flexural members are shown in the following equations:

ACI 318•7.12, 10.5

$$\rho_{\min} = 200 / f_y \quad \text{or } 0.0018 \text{ or } 0.0018$$

$$A_{s,\min} = \rho_{\min} l d \quad (l \text{ is substituted for the ACI 318 symbol } b \text{ for the concrete beam width and is consistent with the footing dimensioning in figure 4.2)}$$

Designers often specify one or two longitudinal No. 4 or No. 5 bars for wall footings as nominal reinforcement when building on questionable soils, when required to maintain continuity of stepped footings on sloped sites, or when conditions result in a changed footing depth. For most residential foundations, however, the primary resistance against differential settlement is provided by the deep beam action of the foundation wall, especially if the wall is reinforced masonry or concrete; footing reinforcement may provide limited benefit. In such cases, the footing simply acts as a platform for the wall construction and distributes loads to a larger soil-bearing area.

Lap Splices

Where reinforcement cannot be installed in one length to meet reinforcement requirements, as in continuous wall footings, reinforcement bars must be lapped to develop the bars' full tensile capacity across the splice. In accordance with ACI 318, a minimum lap length of 40 times the diameter of the reinforcement bar is required for splices in the reinforcement. In addition, the separation between spliced or lapped bars must not exceed eight times the diameter of the reinforcement bar or 6 inches, whichever is less. This is a design or construction issue that frequently causes failures during extreme loading conditions from high winds, storm surge, or seismic events. In accordance with TMS 402, the maximum distance between lapped or spliced bars is one-fifth the splice length or 8 inches, whichever is less.

For foundation systems consisting of a plain concrete footing and a plain concrete stem wall, a minimum of one bar should be provided at the top of the stem wall and at the bottom of the footing. Plain concrete footings supporting walls are permitted in Seismic Design categories A, B or C without longitudinal reinforcement. For buildings located in Seismic Categories D or E, the footings should have at least two continuous longitudinal reinforcing bars no smaller than No. 4 and must have a total area of not less than 0.002 times the gross cross-sectional area of the footing. Footings more than 8 inches (203 millimeters) thick

must have a minimum of one bar at the top and bottom of the footing. Corners and intersections must have continuity of reinforcement.

4.5 Foundation Walls

The objectives of foundation wall design are—

- To transfer the load of the building to the footing or directly to the earth.
- To provide adequate strength, in combination with the footing when required, to prevent differential settlement.
- To provide adequate resistance to shear and bending stresses resulting from lateral soil pressure.
- To provide anchorage for the above-grade structure to resist wind or seismic forces.
- To provide a moisture-resistant barrier to below-ground habitable space, in accordance with the building code.
- To isolate non-moisture-resistant building materials from the ground.

In some cases, masonry or concrete foundation walls incorporate a nominal amount of steel reinforcement to control cracking. Engineering specifications generally require reinforcement of concrete or masonry foundation walls because of somewhat arbitrary limits on minimum steel-to-concrete ratios, even for plain concrete walls. Residential foundation walls are generally constructed of unreinforced or nominally reinforced concrete or masonry or of preservative-treated wood, however. The nominal reinforcement approach has provided many serviceable structures. This section addresses the issue of reinforcement and presents rational design approaches for residential concrete and masonry foundation walls.

In most cases, a designer may select a design for concrete or concrete masonry walls from the prescriptive tables in the applicable residential building code or the IRC (ICC, 2012). Sometimes, however, a specific design applied with reasonable engineering judgment results in a more efficient and economical solution than that prescribed by the codes. The designer may elect to design the wall as either a reinforced or plain concrete wall. The following sections detail design methods for both wall types.

4.5.1 Concrete Foundation Walls

Regardless of the type of concrete foundation wall selected, the designer must determine the nominal and factored loads that, in turn, govern the type of wall (that is, reinforced or unreinforced) that may be appropriate for a given application. The following LRFD load combinations suggested for the design of residential concrete foundation walls are based on table 3.1 of chapter 3:

- 1.4 D + 1.6 H
- 1.2 D + 1.6 H + 1.6 L + 0.5 (L_r or S)
- 1.2 D + 1.6 H + 1.6 (L_r or S) + 0.5 L

In light-frame homes, the first load combination typically governs foundation wall design. Axial load increases moment capacity of concrete walls when they are not appreciably eccentric, as is the case in typical residential construction.

To simplify the calculations, the designer may conservatively assume that the foundation wall acts as a simple span beam with pinned ends, although such an assumption will tend to over predict the stresses in the wall. In any event, the simple span model requires that the wall be adequately supported at its top by the connection to the floor framing and at its base by the connection to the footing or bearing against a basement floor slab. Appendix A contains basic load diagrams and beam equations to assist the designer in analyzing typical loading conditions and element-based structural actions encountered in residential design. Once the loads are known, the designer can perform design checks for various stresses by following ACI 318 and the recommendations contained herein.

As a practical consideration, residential designers must keep in mind that concrete foundation walls typically are a nominal 6, 8, or 10 inches thick. The typical concrete compressive strength used in residential construction is 2,500 or 3,000 psi, although other strengths are available. Table 4.4 illustrates recommended minimum concrete compressive strengths based on use and weathering potential. Typical reinforcement tensile yield strength is 60,000 psi (grade 60) and is primarily a matter of market supply (Refer to section 4.2.1 for more information on concrete and steel reinforcement material properties).

Table 4.4

Minimum Compressive Strength f'_c at 28 Days and Maximum Slump of Concrete

Type or location of concrete construction	Weathering Probability			Maximum slump, in. (mm)
	Negligible f'_c , psi (MPa)	Moderate f'_c , psi (MPa)	Severe f'_c , psi (MPa)	
Type 1: Walls and foundations not exposed to weather; interior slabs-on-grade, not including garage floor slabs	2500 (17)	2500 (17)	2,500 (17)	6(150)
Type 2: Walls, foundations, and other concrete work exposed to weather, except as noted below	2500 (17)	3000 (21)	3000 (21)	6(150)
Type 3: Driveways, curbs, walkways, patios, porches, steps, and stairs exposed to weather; garage floors, slabs	2500 (17)	3500 (24)	4500 (31)	5(125)

f'_c = minimum compressive strength
mm = millimeters
MPa = megapascal
psi = pounds per square inch

4.5.1.1 Plain Concrete Wall Design

ACI 318 defines “plain concrete” as structural concrete with no reinforcement or with less reinforcement than the minimum amount specified for reinforced concrete, and ACI 318•22.0 permits its use in wall design. Structural plain concrete basement, foundation, or other walls below the base are permitted in detached one- and two-family, stud-bearing wall dwellings three stories or fewer in height. Plain concrete walls must be used only in regions of low to moderate seismic risk—Seismic Design Category A, B, or C; otherwise, reinforcing is required. ACI 318 recommends incorporating contraction and isolation joints to control cracking; however, this is not a typical practice for residential foundation walls. Temperature and shrinkage cracking is practically unavoidable but is considered to have negligible impact on the structural integrity of a residential wall. Cracking can be controlled (that is, minimizing potential crack widening) by reasonable use of horizontal reinforcement; chapter 4 of the IRC (ICC, 2012) provides some specific prescriptive requirements governing reinforcement size and spacing in plain concrete foundation walls.

ACI 318 limits plain concrete wall thickness to a minimum of 7.5 inches; however, the IRC (ICC, 2012) permits nominal 6-inch-thick foundation walls when the height of unbalanced fill is less than a prescribed maximum.

Adequate strength must be provided and should be demonstrated by analysis, in accordance with the ACI 318 design equations and the recommendations of this section. Depending on soil loads, analysis should confirm conventional residential foundation wall practice in typical conditions (Refer to example 4.3 of section 4.9 for an illustration of a plain concrete foundation wall design).

Shear Capacity

Shear stress is a result of the lateral loads on a structure associated with wind, earthquake, or backfill forces. Lateral loads are either normal to the wall surface (that is, perpendicular or out of plane) or parallel to the wall surface (that is, in plane). The designer must consider both perpendicular and parallel shear in the wall.

Perpendicular shear is rarely a controlling factor in the design of residential concrete foundation walls except for some foundation walls with substantial backfill loads. Parallel shear also is usually not a controlling factor in residential foundation walls except for walls that are shear walls resisting lateral loads from high winds or seismic events.

If greater shear capacity is required in a plain concrete wall, increasing the wall thickness or increasing the concrete compressive strength may accomplish that purpose. Alternatively, a wall can be reinforced in accordance with section 4.5.1.2.

The following equations apply to both perpendicular and parallel shear, in conjunction with figure 4.3, for plain concrete walls. For parallel shear, the equations do not address overturning and bending action that occurs in a direction

parallel to the wall, particularly for short segments of walls under significant parallel shear load. For concrete foundation walls, that is generally not a concern; for above-grade wood-frame walls, the concern is addressed in chapter 6 in detail.

ACI 318•22.5.4

$$V_u \leq \phi V_n$$

V_u = maximum factored shear load on the wall

$$\phi V_n = \phi \frac{4}{3} \sqrt{f'_c} bh$$

$$\phi = 0.65$$

FIGURE 4.3 *Shear Calculations for Plain Concrete Walls: Variables Defined*

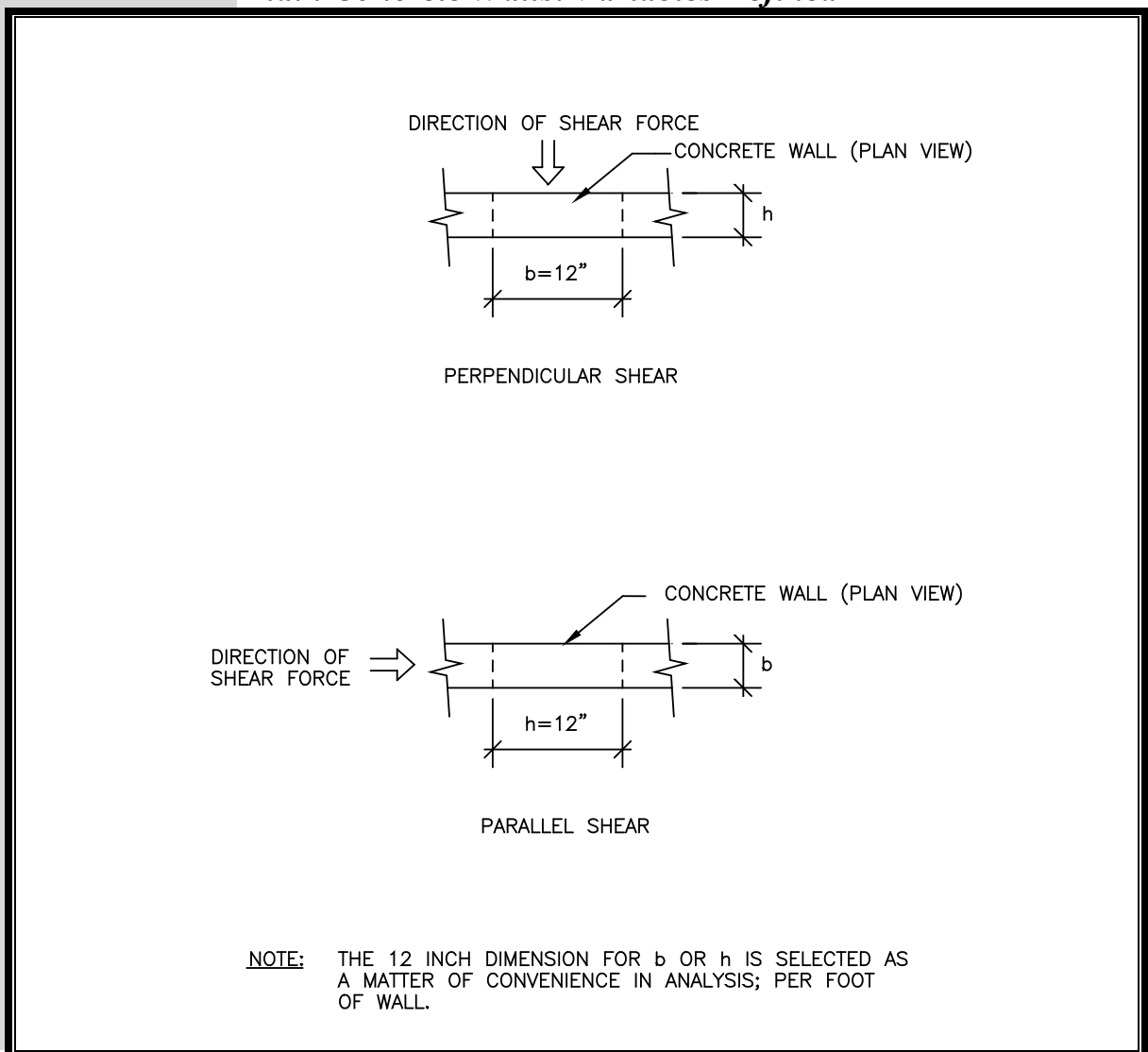

Combined Axial Load and Bending Capacity

The following ACI 318 equations account for the combined effects of axial load and bending moment on a plain concrete wall. The intent is to ensure that the concrete face in compression and the concrete face in tension resulting from factored nominal axial and bending loads do not exceed the factored nominal capacity for concrete. Example 4.4 of section 4.9 demonstrates a method of plotting the interaction equation that follows. (Refer to section 4.5.1.3 for information on interaction diagrams.)

ACI 318•22.5.3, 22.6.3

$$\frac{P_u}{\phi P_n} + \frac{M_u}{\phi M_n} \leq 1 \text{ on the compression face}$$

$$\frac{M_u}{S} - \frac{P_u}{A_g} \leq 5\phi\sqrt{f'_c} \text{ on the tension face}$$

$$M_u > M_{u,\min}$$

M_u = maximum factored nominal moment on wall

$$M_{u,\min} = 0.1hP_u$$

$$M_n = 0.85f'_c S$$

$$P_n = 0.6f'_c \left[1 - \left(\frac{l_c}{32h} \right)^2 \right] A_g$$

P_u = factored nominal axial load on the wall at point of maximum moment

$$\phi = 0.65$$

Even though a plain concrete wall often calculates as adequate, the designer may elect to add a nominal amount of reinforcement for crack control or other reasons. Walls determined inadequate to withstand combined axial load and bending moment may gain greater capacity through increased wall thickness or increased concrete compressive strength. Alternatively, the wall may be reinforced in accordance with section 4.5.1.2. Walls determined to have adequate strength to withstand shear and combined axial load and bending moment may also be checked for deflection, but this is usually not a limiting factor for typical residential foundation walls.

4.5.1.2 Reinforced Concrete Design

ACI 318 allows two approaches to the design of reinforced concrete, with some limits on wall thickness and the minimum amount of steel reinforcement; however, ACI 318 also permits these requirements to be waived in the event that structural analysis demonstrates adequate strength and stability in accordance with ACI 318•14.2.7 (refer to examples 4.4 in section 4.9 for the design of a reinforced concrete foundation wall).

Reinforced concrete walls should be designed in accordance with ACI 318•14.4 by using the strength design method. The following checks for shear

and combined flexure and axial load determine if a wall is adequate to resist the applied loads.

Shear Capacity

Shear stress is a result of the lateral loads on a structure associated with wind, earthquake, or lateral soil forces. The loads are either normal to the wall surface (that is, perpendicular or out of plane), however, or parallel to the wall surface (that is, in plane). The designer must check both perpendicular and parallel shear in the wall to determine if the wall can resist the lateral loads present.

If greater shear capacity is required, it may be obtained by (1) increasing the wall thickness, (2) increasing the concrete compressive strength, (3) adding horizontal shear reinforcement, or (4) installing vertical reinforcement to resist shear through shear friction. Shear friction is the transfer of shear through friction between two faces of a crack. Shear friction also relies on resistance from protruding portions of concrete on either side of the crack and by dowel action of the reinforcement that crosses the crack. The maximum limit on reinforcement spacing of 12 or 24 inches specified in ACI 318•11.5.4 is considered to be an arbitrary limit. When reinforcement is required, practical experience dictates 48 inches as an adequate maximum spacing for residential foundation wall design.

The following equations provide checks for both perpendicular and parallel shear in conjunction with figure 4.4. For parallel shear, the equations do not address overturning and bending action that occurs in a direction parallel to the wall, particularly for short segments of walls under significant parallel shear load. For concrete foundation walls, that generally is not a concern; for above-grade wood-framed walls, the topic is addressed in chapter 6 in detail.

ACI 318•11.5,11.7, 11.10

$$V_u \leq \phi V_n$$

V_u = maximum factored shear load on wall

$$V_n = V_c + V_s$$

$$V_c = 2\sqrt{f'_c} b_w d$$

$$V_s = \frac{A_v f_y d}{s} \leq 8\sqrt{f'_c} b_w d \text{ when } V_u > \phi V_c \text{ when}$$

$$\phi = 0.85$$

Shear-Friction Method

$$V_u \leq \phi V_n$$

$$V_n = A_{vf} f_y \mu \leq 0.2 f'_c A_c \text{ and } \leq 800 A_c \text{ and}$$

$$A_c = b_w h$$

$$\phi = 0.85$$

FIGURE 4.4

***Shear Calculations
in Reinforced Concrete Walls: Variables Defined***

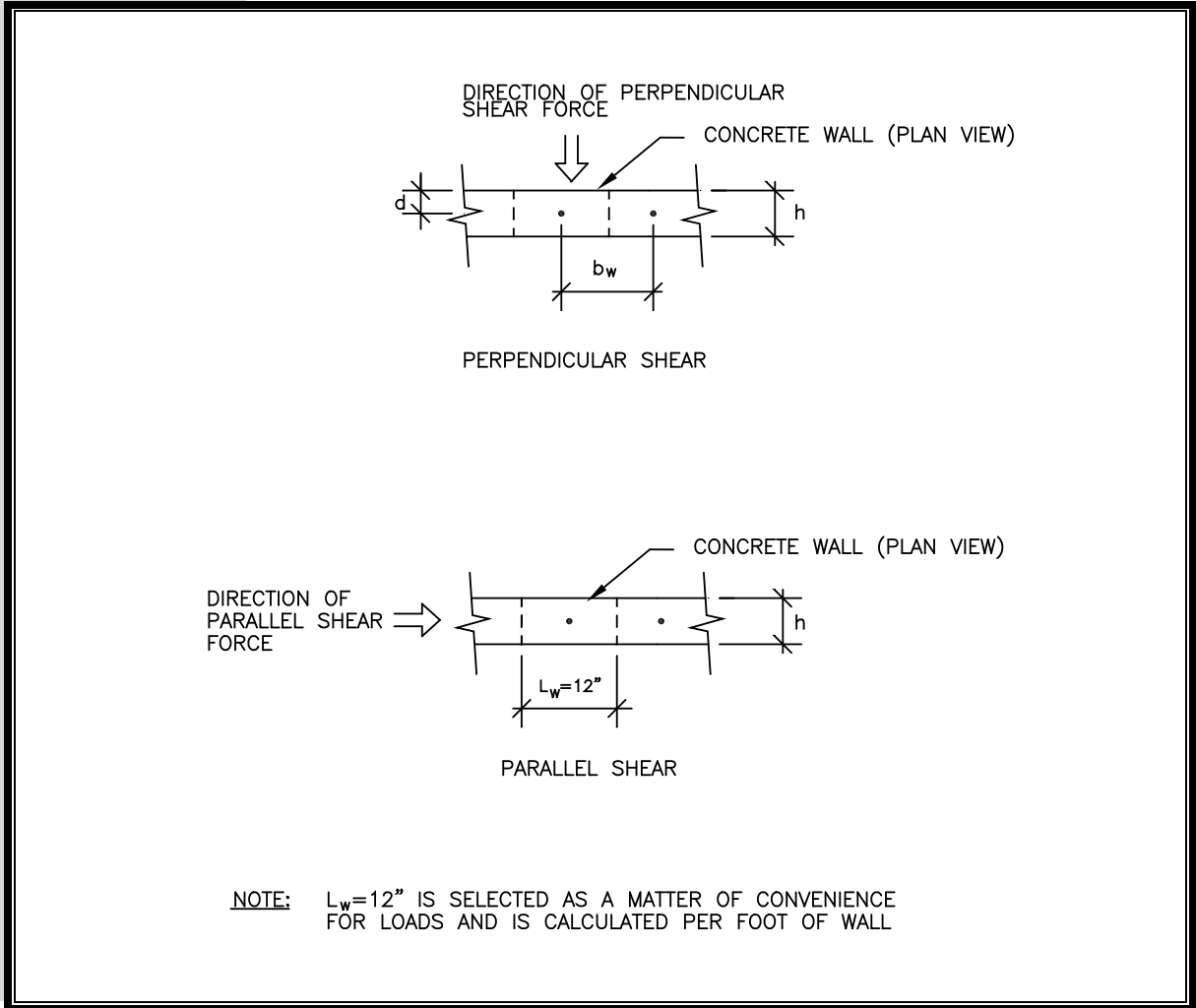

Combined Flexural and Axial Load Capacity

ACI 318 prescribes reinforcement requirements for concrete walls. Foundation walls commonly resist both an applied axial load from the structure above and an applied lateral soil load from backfill. To ensure that the wall's strength is sufficient, the designer must first determine slenderness effects (that is, Euler buckling) in the wall. ACI 318•10.10 provides an approximation method to account for slenderness effects in the wall; however, the slenderness ratio must not be greater than 100. The slenderness ratio is defined in the following section as the ratio between unsupported length and the radius of gyration. In residential construction, the approximation method, more commonly known as the moment magnifier method, is usually adequate because slenderness ratios typically are less than 100 in foundation walls.

The moment magnifier method uses the relationship of the axial load and lateral load in addition to wall thickness and unbraced height to determine a multiplier of 1 or greater, which accounts for slenderness in the wall. The multiplier is termed the *moment magnifier*. It magnifies the calculated moment in the wall resulting from the lateral soil load and any eccentricity in axial load. Together, the axial load and magnified moment are used to determine whether the foundation wall section is adequate to resist the applied loads. The following steps are required to determine the amount of reinforcement required in a typical residential concrete foundation wall to resist combined flexure and axial loads—

- Calculate axial and lateral loads.
- Verify that the nonsway condition applies.
- Calculate slenderness.
- Calculate the moment magnifier.
- Plot the axial load and magnified moment on an interaction diagram.

The following sections discuss the procedure in detail.

Slenderness

Conservatively, assuming that the wall is pinned at the top and bottom, slenderness in the wall can be calculated by using the equation that follows. The effective length factor k is conservatively assumed to equal 1 in this condition. A value of k less than 1 (for example, 0.7) may actually better represent the end conditions (that is, nonpinned state) of residential foundation walls.

ACI 318•10.10

$$\frac{kl_u}{r} < 34 \quad \text{slenderness ratio}$$

$$r = \sqrt{\frac{I}{A}} = \sqrt{\frac{bd^3/12}{bd}} = \sqrt{\frac{d^2}{12}} \quad \text{radius of gyration}$$

Moment Magnifier Method

The moment magnifier method is an approximation method allowed in ACI 318•10.10 for concrete walls with a slenderness ratio less than or equal to 100. If the slenderness ratio is less than 34, then the moment magnifier is equal to 1 and requires no additional analysis. The design procedure and equations that follow align with ACI 318•10.12. The equation for EI , as listed in ACI 318, is applicable to walls containing a double layer of steel reinforcement. Residential walls typically contain only one layer of steel reinforcement; therefore, the equation for EI , as listed herein, is based on section 10.12 (ACI, 2008).

ACI 318•10.12.3

$$M_{u, \text{mag}} = \delta M_u \leftarrow \text{Magnified Moment}$$

$$\delta = \frac{C_m}{1 - \left(\frac{P_u}{0.75P_c} \right)} \geq 1$$

$$P_c = \frac{\pi^2 EI}{(kl_u)^2}$$

$$C_m = 0.6$$

or

$C_m = 1$ for members with transverse loads between supports

$$M_{u, \text{min}} = P_u (0.6 + 0.03h)$$

$$EI = \frac{0.4E_c I_g}{\beta} \geq \frac{E_c I_g \left(0.5 - \frac{e}{h} \right)}{\beta} \geq \frac{0.1E_c I_g}{\beta}$$

$$e = \frac{M_2}{P_u}$$

$$\beta = 0.9 + 0.5\beta_d^2 - 12\rho \geq 1.0$$

$$\rho = \frac{A_s}{A_g}$$

$$\beta_d = \frac{P_{u, \text{dead}}}{P_u}$$

$$E_c = 57,000\sqrt{f'_c} \quad \text{or} \quad w_c^{1.5} 33\sqrt{f'_c}$$

Given that the total factored axial load in residential construction typically falls below 3,000 pounds per linear foot of wall and that concrete compressive strength typically is 3,000 psi, table 4.5 provides prescriptive moment magnifiers.

Interpolation is permitted between wall heights and between factored axial loads. Depending on the reinforcement ratio and the eccentricity present, some economy is lost in using the table 4.5 values instead of the preceding calculation method.

TABLE 4.5 *Simplified Moment Magnification Factors, δ_{ns}*

Minimum Wall Thickness (inches)	Maximum Wall Height (feet)	Factored Axial Load (plf)	
		2,000	4,000
5.5	8	1.07	1.15
	10	1.12	1.26
7.5	8	1.03	1.06
	10	1.04	1.09
9.5	8	1.00	1.03
	10	1.00	1.04

Example 4.7 in section 4.9 presents the complete design of a reinforced concrete foundation wall. The magnified moment and corresponding total factored axial load are plotted on an interaction diagram as shown in figure 4.5 (Refer to section 4.5.1.3 for a description of interaction diagrams and additional resources).

4.5.1.3 Interaction Diagrams

An interaction diagram is a graphic representation of the relationship between the axial load and bending capacity of a reinforced or plain concrete wall. The primary use of interaction diagrams is as a design aid for selecting predetermined concrete wall or column designs for varying loading conditions. Several publications provide interaction diagrams for use with concrete; however, these publications typically focus on column or wall design that is heavily reinforced, in accordance with design loads common in commercial construction. Residential concrete walls are either plain or slightly reinforced with one layer of reinforcement typically placed near the center of the wall. Plain and reinforced concrete interaction diagrams for residential applications and the methods for deriving them may be found in *Structural Design of Insulating Concrete Form Walls in Residential Construction* (PCA, 1998). StructurePoint, an affiliate of the Portland Cement Association (PCA) and the Cement Association of Canada, also offers a computer program that plots interaction diagrams based on user input; the program is titled *spColumn* ([PCACOL](#)).

An interaction diagram assists the designer in determining the wall's structural adequacy under various loading conditions (in other words, combinations of axial and bending loads). Figure 4.5 illustrates interaction diagrams for plain and reinforced concrete. Both the design points located within

the interaction curve for a given wall height and the reference axes represent a combination of axial load and bending moment that the wall can safely support. The most efficient design is close to the interaction diagram curve. For residential applications, the designer, realizing that the overall design process is not exact, may accept designs within plus or minus 5 percent of the interaction curve.

FIGURE 4.5 *Typical Interaction Diagrams for Plain and Reinforced Concrete Walls*

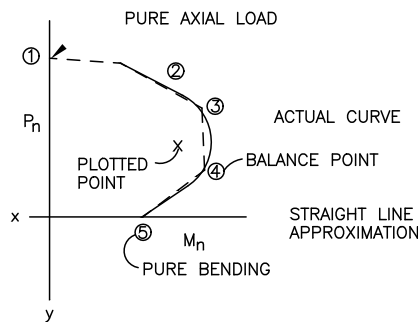
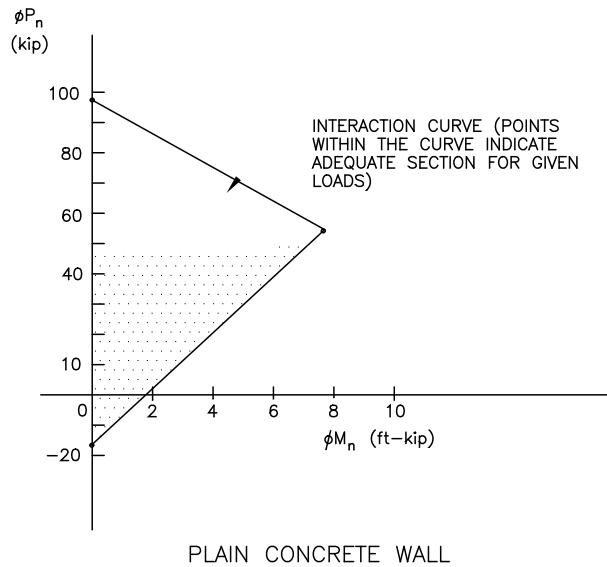

Notes:

- ϕP_n = factored nominal load
- ϕM_n = factored nominal moment
- P_n = nominal load
- M_n = nominal moment
- ft-kip = 1,000 ft-lb

4.5.1.4 Minimum Concrete Wall Reinforcement

Plain concrete foundation walls can provide serviceable structures when they are adequately designed (see section 4.5.1.1). When reinforcement is used to provide additional strength in thinner walls or to address more heavily loaded conditions, tests have shown that horizontal and vertical wall reinforcement spacing limited to a maximum of 48 inches on center results in performance that agrees reasonably well with design expectations (Roller, 1996). The designer should still ensure that the reinforcement area meets required minimum specified by the building code and that the reinforcement area is determined by acceptable methods.

ACI 318•22.6.6.5 requires two No. 5 bars around all wall openings. The rebar, at a minimum, should be the same size required by the design of the reinforced wall, or a minimum No. 4 for plain concrete walls. In addition, a lintel (that is, concrete beam) is required at the top of wall openings; refer to section 4.5.1.6 for more detail on lintels.

4.5.1.5 Concrete Wall Deflection

ACI 318 does not specifically limit wall deflection; therefore, deflection usually is not analyzed in residential foundation wall design. Regardless, a deflection limit of $L/240$ for unfactored soil loads is not unreasonable for below-grade walls that are reinforced concrete. For plain concrete walls, such large deflections are not tolerable, and designing such walls for strength alone is considered to provide adequate rigidity and serviceability (refer to section 4.4). When using the moment magnifier method, the designer should apply the calculated moment magnification factor to the unfactored load moments used in conducting the deflection calculations. The calculation of wall deflection should also use effective section properties based on $E_c I_g$ for plain concrete walls and $E_c I_e$ for reinforced concrete walls; refer to ACI 318•9.5.2.3 to calculate the effective moment of inertia, I_e .

If unfactored load deflections prove unacceptable, the designer may increase the wall thickness or the amount of vertical wall reinforcement. For some residential loading conditions, however, satisfying reasonable deflection requirements should not be a limiting condition.

4.5.1.6 Concrete Wall Lintels

The loads over openings in concrete walls are supported by concrete, steel, precast concrete, cast stone, or reinforced masonry wall lintels. Wood headers also are used when not supporting concrete construction above and when continuity at the top of the wall (that is, a bond beam) is not critical, as in high-hazard seismic or hurricane coastal zones, or is maintained sufficiently by a wood sill plate and other construction above.

This section focuses on the design of concrete lintels in accordance with chapters 10 and 11 of ACI 318. The concrete lintel often is assumed to act as a

simple span, with each end pinned; however, the assumption implies no top reinforcement to transfer the moment developed at the end of the lintel. Under that condition, the lintel is assumed to be cracked at the ends, such that the end moment is zero, and the shear must be transferred from the lintel to the wall through the bottom reinforcement.

If the lintel is assumed to act as a fixed-end beam, the top and bottom reinforcement should be sufficiently embedded beyond each side of the opening to fully develop a moment-resisting end in the lintel. Although more complicated to design and construct, a fixed-end beam reduces the maximum bending moment (that is, $wl^2/12$ instead of $wl^2/8$) on the lintel and allows increased spans. A concrete lintel cast in a concrete wall acts somewhere between a true simple span beam and a fixed-end beam. Thus, a designer may design the bottom bar for a simple span condition and the top bar reinforcement for a fixed-end condition (conservative). Often, a No. 4 bar is placed at the top of each wall story to help tie the walls together (serving as a bond beam), which also can serve as the top reinforcement for concrete lintels. Figure 4.6 depicts the cross section and dimensions for analysis of concrete lintels. Example 4.5 demonstrates the design of a concrete lintel; refer to section 4.9.

For additional information on concrete lintels and their design procedure, refer to the *Structural Design of Insulating Concrete Form Walls in Residential Construction* (PCA, 1998) and to *Testing and Design of Lintels Using Insulating Concrete Forms* (HUD, 2000). The latter demonstrates, through testing, that shear reinforcement (that is, stirrups) of concrete lintels is not necessary for short spans (in other words, 3 feet or less) with lintel depths of 8 inches or more. This research also indicates that the minimum reinforcement requirements in ACI 318 for beam design are conservative when a minimum No. 4 rebar is used as bottom reinforcement. Further, lintels with small span-to-depth ratios can be accurately designed as deep beams in accordance with ACI 318 when the minimum reinforcement ratios are met (Refer to ACI 318•11.4).

FIGURE 4.6

Design Variables Defined for Lintel Bending and Shear

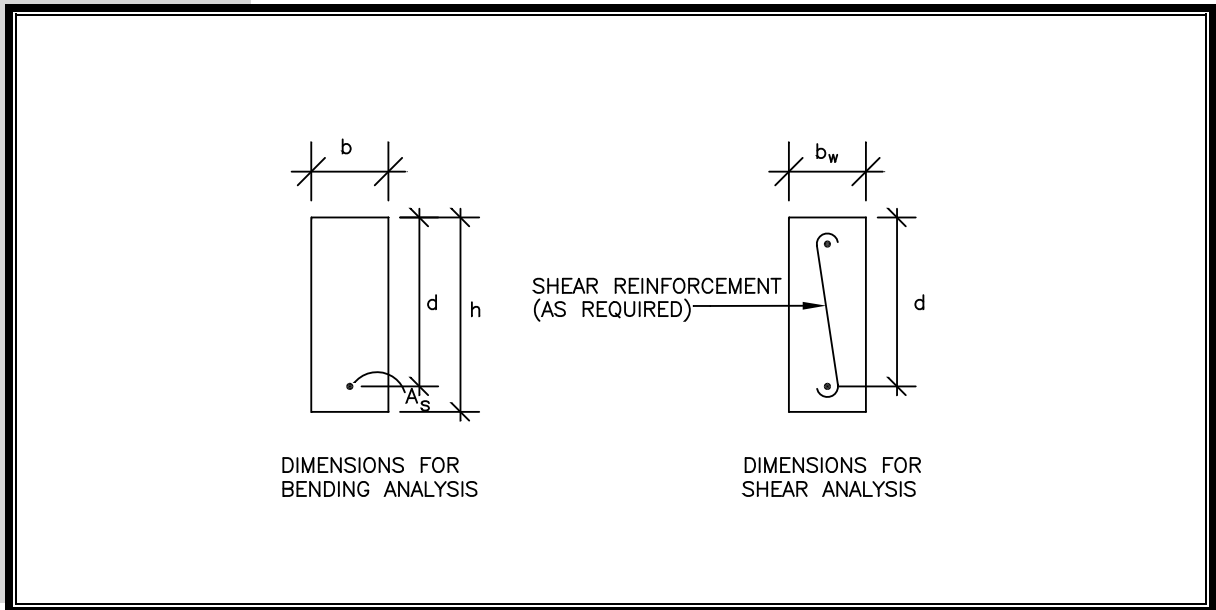

Flexural Capacity

The following equations are used to determine the flexural capacity of a reinforced concrete lintel, in conjunction with figure 4.6. An increase in the lintel depth or area of reinforcement is suggested if greater bending capacity is required. As a practical matter, though, lintel thickness is limited to the thickness of the wall in which a lintel is placed. In addition, lintel depth often is limited by the floor-to-floor height and the vertical placement of the opening in the wall. In many cases, therefore, increasing the amount or size of reinforcement is the most practical and economical solution.

ACI 318•10

$$M_u \leq \phi M_n$$

$$M_u = \frac{w\ell^2}{12} \text{ for fixed-end beam model}$$

$$M_u = \frac{w\ell^2}{8} \text{ for simple span beam model}$$

$$\phi M_n = \phi A_s f_y \left(d - \frac{a}{2} \right)$$

$$a = \frac{A_s f_y}{0.85 f'_c b}$$

$$\phi = 0.9$$

Shear Capacity

Concrete lintels are designed for shear resulting from wall, roof, and floor loads, in accordance with the equations below and figure 4.6.

ACI 318•11

$$V_u \leq \phi V_n$$

$$V_n = V_c + V_s$$

$$V_c = 2\sqrt{f'_c} b_w d$$

$$V_s = \frac{A_v f_y d}{s} \leq 8\sqrt{f'_c} b_w d \text{ when } V_u > \phi V_c$$

$$A_{v,\min} = \frac{50b_w s}{f_y} \text{ when } V_u > \frac{\phi V_c}{2}$$

$$s \leq \text{minimum of } \left\{ \frac{d}{2} \text{ or } 24 \text{ in} \right\}$$

$$s \leq \text{minimum of } \left\{ \frac{d}{4} \text{ or } 12 \text{ in} \right\} \text{ when } V_s > 4\sqrt{f'_c} b_w d$$

$$\phi = 0.85$$

Check Concrete Lintel Deflection

ACI 318 does not specifically limit lintel deflection; therefore, a reasonable deflection limit of $L/240$ for unfactored live loads is suggested. The selection of an appropriate deflection limit, however, is subject to designer discretion. In some applications, a lintel deflection limit of $L/180$ with live and dead loads is adequate. A primary consideration is whether the lintel is able to move independently of door and window frames. Calculation of lintel deflection should use unfactored loads and the effective section properties $E_c I_e$ of the assumed concrete section (Refer to ACI 318•9.5.2.3 to calculate the effective moment of inertia I_e of the section).

4.5.2 Masonry Foundation Walls

Masonry foundation wall construction is common in residential construction. It is used in a variety of foundation types, including basements, crawl spaces, and slabs-on-grade. For prescriptive design of masonry foundation walls in typical residential applications, a designer or builder may use the IRC (ICC, 2012) or the local residential building code.

ACI 530 develops methods for the design of masonry foundation walls by using allowable stress design; therefore, design loads may be determined according to load combinations presented in chapter 3 as follows:

- $D + H$
- $D + H + 0.75 (L_r \text{ or } S) + 0.75 L$

In light-frame homes, the first load combination typically governs masonry walls for the same reasons stated in section 4.5.1 for concrete foundation walls. To simplify the calculations, the designer may conservatively assume that the wall story acts as a simple span with pinned ends, although such an assumption may tend to overpredict the stresses in the wall (for a discussion on calculating the loads on a structure, refer to chapter 3). Appendix A contains basic load diagrams and equations to assist the designer in calculating typical loading conditions and element-based structural actions encountered in residential design. Further, walls that are determined to have adequate strength to withstand shear and combined axial load and bending moment generally satisfy unspecified deflection requirements; therefore, foundation wall deflection is not discussed in this section. If desired, however, deflection may be considered as discussed in section 4.5.1.5 for concrete foundation walls.

To follow the design procedure, the designer must know the strength properties of various types and grades of masonry, mortar, and grout currently available on the market; section 4.2.2 discusses the material properties. With the loads and material properties known, the designer can then perform design checks for various stresses by following American Concrete Institute's ACI 530 (ACI, 2013). Residential construction rarely involves detailed masonry specifications but rather makes use of standard materials and methods familiar to local suppliers and trades.

An engineer's inspection of a home is hardly ever required or requested under typical residential construction conditions. Inspection should be considered when masonry construction is specified in high-hazard seismic or hurricane-prone areas. ACI 530 makes no distinction between inspected and noninspected masonry walls and, therefore, does not require adjustments in allowable stresses based on level of inspection.

Residential designers should keep in mind that concrete masonry units (that is, block) are readily available in nominal 6-, 8-, 10-, and 12-inch thicknesses. It is generally more economical if the masonry unit compressive strength f_m ranges between 1,500 and 3,000 psi. The standard block used in residential and light commercial construction is usually rated at 1,900 psi.

4.5.2.1 Unreinforced Masonry Design

ACI 530 addresses the design of unreinforced masonry to ensure that unit stresses and flexural stresses in the wall do not exceed certain maximum allowable stresses. ACI 530 provides for two methods of design: an empirical design approach and an ASD approach.

Walls may be designed in accordance with ACI 530•TMS 402 by using the empirical design method under the following conditions:

- The building is not located in Seismic Design Category D or E, as defined in NEHRP 2009 (FEMA, 2009) or ASCE 7-10 (that is, Seismic Zones 3 or 4 in most current and local building codes). (Refer to chapter 3.)

- Foundation walls do not exceed 8 feet in unsupported height.
- The distance between perpendicular vertical or horizontal supports for loadbearing masonry walls is a maximum of 18 times the wall thickness. This limit typically does not apply to residential basements as required in the IRC (ICC, 2012).
- Compressive stresses do not exceed the allowable stresses listed in ACI 530; compressive stresses are determined by dividing the design load by the gross cross-sectional area of the unit, per ACI 530.
- Backfill heights do not exceed those listed in table 4.5.
- Backfill material is nonexpansive and is tamped no more than necessary to prevent excessive settlement.
- Masonry is laid in running bond with Type M or S mortar.
- Lateral support is provided at the top of the foundation wall before backfilling.

Drainage is important when using the empirical table because lack of good drainage may substantially increase the lateral load on the foundation wall if the soil becomes saturated. As required in standard practice, the finish grade around the structure should be adequately sloped (minimum 1 inch of fall per foot of distance from the structure) to drain surface water away from the foundation walls. The backfill material should also be drained to remove ground water from poorly drained soils.

Out-of-plane bracing of the masonry foundation walls can be achieved by providing lateral support from the wood floor framing that is supported by and connected to the wall. The most common method of connection is a wood sill plate anchored to the top of the masonry wall with anchor bolts, and nailing of the floor framing to the sill plate (see chapter 7). Bracing by the floor system should be in place prior to the wall being backfilled.

When the limits of the empirical design method are exceeded, the ASD procedure for unreinforced masonry, as detailed herein, provides a more flexible approach by which walls are designed as compression and bending members, in accordance with ACI 530•2.2.

TABLE 4.6 *Nominal Wall Thickness for 8-Foot-High Masonry Foundation Walls^{1, 2}*

Nominal Wall Thickness	Maximum Unbalanced Backfill Height		
	Hollow Unit Masonry	Solid Unit Masonry	Fully Grouted Unit Masonry
6 inches	3	5	5
8 inches	5	5	7
10 inches	6	7	8
12 inches	7	7	8

Source: Modified from the ACI 530•9.6 by using the IRC (ICC, 2012).

Notes:

¹Based on a backfill with an assumed equivalent fluid density of 30 pcf.

²Backfill height is measured from the top of the basement slab to the finished exterior grade; wall height is measured from the top of the basement slab to the top of the wall.

The fundamental assumptions, derivation of formulas, and design procedures for ASD are similar to those developed for strength-based design for concrete except that the material properties of masonry are substituted for those of concrete. Allowable masonry stresses used in ASD are expressed in terms of a fraction of the specified compressive strength of the masonry at the age of 28 days: f_m . A typical fraction of the specified compressive strength is 0.25 or 0.33, which equates to a conservative safety factor between 3 and 4 relative to the minimum specified masonry compressive strength. Table 4.7 provides design values for flexural tension stress. As in plain concrete, unreinforced masonry has very low tension capacity. The following design checks are used to determine if an unreinforced masonry wall is structurally adequate (refer to example 4.6 for the design of an unreinforced concrete masonry wall).

TABLE 4.7 *Allowable Flexural Tension Stresses (F_a) for Allowable Stress Design of Unreinforced Masonry*

Type of Masonry Unit Construction	Mortar Type M or S	
	Portland Cement/Lime (psi)	Masonry Cement and Air-Entrained Portland Cement/Lime (psi)
Normal to Bed Joints		
Solid	53	32
Hollow ¹		
UngROUTed	33	20
Fully grouted	86	81
Parallel to Bed Joints in Running Bond		
Solid	106	64
Hollow		
UngROUTed/partially grouted	66	40
Fully grouted	106	64

Source: Table 2.2.3.2 TMS 402

Note:

¹For partially grouted masonry, allowable stresses may be determined on the basis of linear interpolation between fully grouted and ungrouted hollow units, based on the amount of grouting.

Shear Capacity

Shear stress is a result of the lateral loads on the structure associated with wind, earthquakes, or backfill forces. Lateral loads are both normal to the wall surface (that is, perpendicular or out of plane) and parallel to the wall surface (that is, parallel or in plane). Both perpendicular and parallel shear should be checked, as either could be a controlling factor in residential foundation walls.

If greater perpendicular shear capacity is required, it may be obtained by (1) increasing the wall thickness, (2) increasing the masonry unit compressive strength, or (3) adding vertical reinforcement in grouted cells. If greater parallel

shear capacity is required, it may be obtained by (1) increasing the wall thickness, (2) reducing the size or numbers of wall openings, or (3) adding horizontal joint reinforcement. Horizontal truss-type joint reinforcement can substantially increase parallel shear capacity, provided that it is installed properly in the horizontal mortar bed joints. If not installed properly, it can create a place of weakness in the wall, particularly in out-of-plane bending of an unreinforced masonry wall.

The equations that follow are used to check perpendicular and parallel shear in masonry walls. The variable N_v is the axial design load acting on the wall at the point of maximum shear. The equations are based on A_n , which is the net cross-sectional area of the masonry. For parallel shear, the equations do not address overturning and bending action that occurs in a direction parallel to the wall, particularly for short segments of walls under significant parallel shear load.

ACI 530•2.2.5

$$f_v \leq F_v$$

$$f_v = \frac{3V}{2A_n}$$

$$F_v = \text{minimum of } \begin{cases} 1.5\sqrt{f'_m} & \text{for axial and shear members} \\ 120\text{psi} \\ 37\text{psi} + 0.45 \frac{N_v}{A_n} & \text{for running bond} \end{cases}$$

Axial Compression Capacity

The following equations from ACI 530•2.3 are used to design masonry walls and columns for compressive loads only. They are based on the net cross-sectional area of the masonry, including grouted and mortared areas.

ACI 530•2.3

Columns

$$P \leq P_a$$

$$P_a = (0.25f'_m A_n + 0.65A_{st}F_s) \left[1 - \left(\frac{h}{140r} \right)^2 \right] \quad \text{where } \frac{h}{r} \leq 99$$

$$P_a = (0.25f'_m A_n + 0.65A_{st}F_s) \left(\frac{70r}{h} \right)^2 \quad \text{where } \frac{h}{r} > 99$$

$$P_{a,\text{maximum}} = F_a A_n$$

$$r = \sqrt{\frac{I}{A_n}}$$

Walls

$$f_a \leq F_a$$

$$F_a = (0.25f'_m) \left[1 - \left(\frac{h}{140r} \right)^2 \right] \quad \text{where } \frac{h}{r} \leq 99$$

ACI 530•2.3

$$f_a = \frac{P}{A}$$

$$F_a = (0.25f'_m) \left(\frac{70r}{h} \right)^2 \quad \text{where } \frac{h}{r} > 99$$

$$r = \sqrt{\frac{I}{A_n}} \cong \frac{t}{\sqrt{12}}$$

$$P_e = \frac{\pi^2 E_m I}{h^2} \left(1 - 0.577 \frac{e}{r} \right)^3$$

$$P < 1/4 P_e$$

$$E_m = 900 F'_m$$

Combined Axial Compression and Flexural Capacity

The following equations from ACI 530 determine the relationship of the combined effects of axial load and bending moment on a masonry wall.

ACI 530•2.3

$$\frac{f_a}{F_a} + \frac{f_b}{F_b} \leq 1$$

$$f_a = \frac{P}{A_n}$$

$$P \leq 0.25P_e$$

$$F_a = (0.25f'_m) \left[1 - \left(\frac{h}{140r} \right)^2 \right] \quad \text{for } \frac{h}{r} \leq 99$$

$$F_a = (0.25f'_m) \left(\frac{70r}{h} \right)^2 \quad \text{for } \frac{h}{r} > 99$$

$$r = \sqrt{\frac{I}{A_n}}$$

$$f_b = \frac{M}{S}$$

$$F_b = 0.33f'_m$$

$$P_e = \frac{\pi^2 E_m I}{h^2} \left(1 - 0.577 \frac{e}{r} \right)^3$$

$$E_m = 900f'_m$$

$$f_t < F_t$$

$$F_t = \text{ACI 530 Table 2.2.3.2}$$

$$f_t = \frac{-P}{A_n} + \frac{M}{S}$$

Tension Capacity

ACI 530 provides allowable values for flexural tension transverse to the plane of a masonry wall. Standard principles of engineering mechanics determine the tension stress resulting from the bending moment caused by lateral (that is, soil) loads and offset by axial (that is, dead) loads.

ACI 530•2.3

$$f_t < F_t$$
$$F_t = \text{ACI 530 Table 2.2.3.2}$$
$$f_t = \frac{P}{A_n} + \frac{M}{S}$$

Even though an unreinforced masonry wall may calculate as adequate, the designer may consider adding a nominal amount of reinforcement to control cracking (Refer to section 4.5.2.3 for a discussion on nominal reinforcement).

Walls determined inadequate to withstand combined axial load and bending moment may gain greater capacity through (1) increased wall thickness, (2) increased masonry compressive strength, or (3) the addition of steel reinforcement. Usually the most effective and economical solution for providing greater wall capacity in residential construction is to increase wall thickness, although reinforcement also is common. Section 4.5.2.2 discusses the design procedure for a reinforced masonry wall.

4.5.2.2 Reinforced Masonry Design

When unreinforced concrete masonry wall construction does not satisfy all design criteria (load, wall thickness limits, and so on), reinforced walls may be designed by following the ASD procedure or the strength-based design procedure of ACI 530. The ASD procedure outlined herein describes an approach by which walls are designed in accordance with ACI 530•2.3. Although not discussed in detail herein, walls may also be designed by following the strength-based design method specified in ACI 530.

For walls designed in accordance with ACI 530•2.3 using the ASD method, the fundamental assumptions, derivation of formulas, and design procedures are similar to those for design using concrete except that the material properties of masonry are substituted for those of concrete. Allowable masonry stresses used in ASD are expressed in terms of a fraction of the specified compressive strength of the masonry at the age of 28 days, f'_m . A typical fraction of the specified compressive strength is 0.25, which equates to a conservative safety factor of 4. The following design checks determine whether a reinforced masonry wall is structurally adequate (refer to example 4.7 for the design of a reinforced concrete masonry wall).

Shear Capacity

Shear stress is a result of lateral loads on the structure associated with wind, earthquakes, or backfill forces. Lateral loads are both normal to the wall surface (that is, perpendicular or out of plane) and parallel to the wall surface (that is, parallel or in plane). Both perpendicular and parallel shear should be checked; perpendicular shear may be a controlling factor in the design of masonry walls, and parallel shear could be a controlling factor if the foundation is partially or fully above grade (such as a walkout basement) with a large number of openings.

The equations that follow check perpendicular and parallel shear in conjunction with figure 4.7. Some building codes include a “j” coefficient in these equations. The “j” coefficient defines the distance between the center of the compression area and the center of the tensile steel area; however, it often is dismissed or approximated as 0.9. If greater parallel shear capacity is required, it may be obtained in a manner similar to that recommended in the previous section for unreinforced masonry design. For parallel shear, the equations do not address overturning and bending action that occurs in a direction parallel to the wall, particularly for short segments of walls under significant parallel shear load.

ACI 530•7.5

$$f_v \leq F_v$$

$$f_v = \frac{V}{A_{nv}}$$

$$F_v = 1.0\sqrt{f'_m} \leq 50 \text{ psi for flexural members}$$

$$F_v = \frac{1}{3} \left(4 - \frac{M}{Vd} \right) \sqrt{f'_m} \leq \left(80 - 45 \frac{M}{Vd} \right) \text{ psi}$$

$$\text{for shear walls where } \frac{M}{Vd} < 1$$

$$F_v = 1.0\sqrt{f'_m} \leq 35 \text{ psi}$$

$$\text{for shear walls where } \frac{M}{Vd} \geq 1$$

If the shear stress exceeds the above allowables for masonry only, the designer must design shear reinforcing with the shear stress equation changes, in accordance with ACI 530•2.3.5. In residential construction, increasing the wall thickness or grouting additional cores is generally more economical than using shear reinforcement. If shear reinforcement is desired, refer to ACI 530. ACI 530 limits vertical reinforcement to a maximum spacing (s) of 48 inches. Flexural or axial stresses must be accounted for to ensure that a wall is structurally sound. Axial loads increase compressive stresses and reduce tension stresses and may be great enough to keep the masonry in an uncracked state under a simultaneous bending load.

Axial Compression Capacity

The following equations from ACI 530•2.3 are used to determine whether a masonry wall can withstand conditions when compressive loads act only on walls and columns (that is, interior load-bearing wall or floor beam support pier). As with concrete, compressive capacity usually is not an issue in supporting a typical light-frame home. An exception may occur with the bearing points of long-spanning beams. In such a case, the designer should check bearing capacity by using ACI 530•2.1.7.

FIGURE 4.7

Shear Calculations in Reinforced Concrete Masonry Walls: Variables Defined

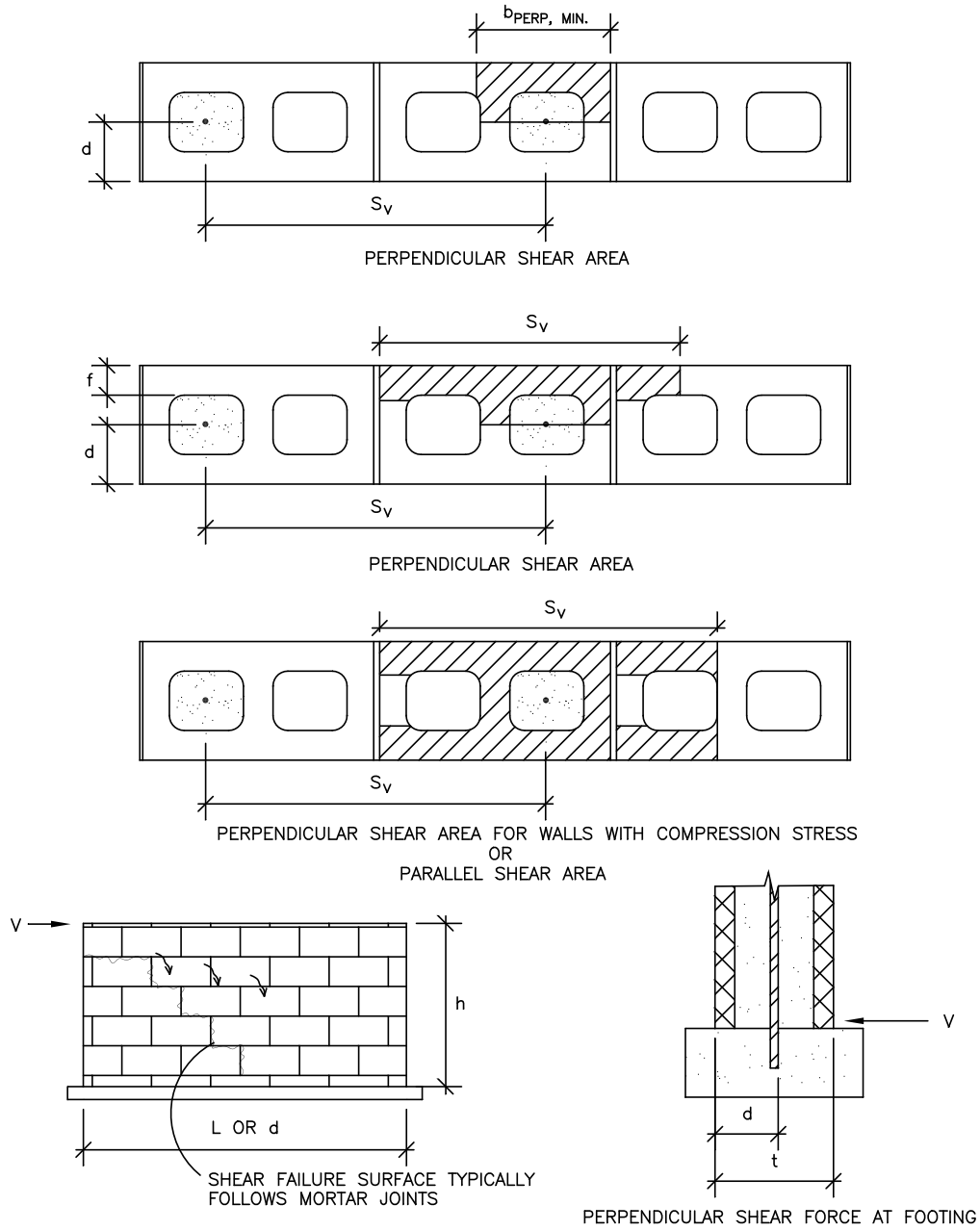

Notes:

d = distance to neutral axis

L = length

S_v = perpendicular shear area

t = thickness

v = perpendicular shear

ACI 530•2.3

Columns

$$P \leq P_a$$

$$P_a = (0.25f'_m A_n + 0.65A_{st}F_s) \left[1 - \left(\frac{h}{140r} \right)^2 \right] \quad \text{where } \frac{h}{r} \leq 99$$

$$P_a = (0.25f'_m A_n + 0.65A_{st}F_s) \left(\frac{70r}{h} \right)^2 \quad \text{where } \frac{h}{r} > 99$$

$$P_{a,\text{maximum}} = F_a A_n$$

$$r = \sqrt{\frac{I}{A_e}}$$

Walls

$$f_a \leq F_a$$

$$F_a = (0.25f'_m) \left[1 - \left(\frac{h}{140r} \right)^2 \right] \quad \text{where } \frac{h}{r} \leq 99$$

$$F_a = (0.25f'_m) \left(\frac{70r}{h} \right)^2 \quad \text{where } \frac{h}{r} > 99$$

$$r = \sqrt{\frac{I}{A_e}}$$

Calculation using the preceding equations is based on A_e , which is the effective cross-sectional area of the masonry, including grouted and mortared areas substituted for A_n .

Combined Axial Compression and Flexural Capacity

In accordance with ACI 530•2.3.2, the design tensile forces in the reinforcement due to flexure shall not exceed 20,000 psi for grade 40 or 50 steel, 24,000 psi for grade 60 steel, or 30,000 psi for wire joint reinforcement. As stated, most reinforcing steel in the U.S. market today is grade 60. The following equations pertain to walls that are subject to combined axial and flexure stresses.

ACI 530•7.3

$$F_b = 0.33f'_m$$

$$f_b = \frac{M}{S} \leq \left(1 - \frac{f_a}{F_a} \right) F_b$$

Columns

$$\frac{P}{P_a} + \frac{f_b}{F_b} \leq 1$$

ACI 530•7.3

$$P_a = (0.25f'_m A_n + 0.65A_{st}F_s) \left[1 - \left(\frac{h}{140r} \right)^2 \right] \quad \text{where } h/r \leq 99$$

$$P_a = (0.25f'_m A_n + 0.65A_{st}F_s) \left(\frac{70r}{h} \right)^2 \quad \text{where } h/r > 99$$

Walls

$$\frac{f_a}{F_a} + \frac{f_b}{F_b} \leq 1$$

$$f_a = \frac{P}{A_e} \leq 0.33f'_m \quad \text{due to flexure only or flexure in combination with axial load}$$

$$F_a = (0.25f'_m) \left[1 - \left(\frac{h}{140r} \right)^2 \right] \quad \text{for } h/r \leq 99$$

$$F_a = (0.25f'_m) \left(\frac{70r}{h} \right)^2 \quad \text{for } h/r > 99$$

Walls determined inadequate to withstand combined axial load and bending moment may gain greater capacity through (1) increased wall thickness, (2) increased masonry compressive strength, or (3) added steel reinforcement.

4.5.2.3 Minimum Masonry Wall Reinforcement

For reinforced concrete masonry shear walls, ACI 530 stipulates minimum reinforcement limits as shown herein. The designer should rely on experience in local practice and local building code provisions for prescriptive masonry foundation or above-grade wall design in residential applications.

ACI 530•2.3.5

$$A_{s,\text{required}} = \frac{M}{F_s d}$$

4.5.2.4 Masonry Wall Lintels

Openings in masonry walls are constructed by using steel, precast concrete, or reinforced masonry lintels. Wood headers also are used when they do not support masonry construction above and when continuity at the top of the wall (a bond beam) is not required or is adequately provided within the system of wood-framed construction above. Steel angles are the simplest shapes and are suitable for openings of moderate width typically found in residential foundation walls. The angle should have a horizontal leg of the same width as the thickness of the concrete masonry that it supports. Openings may require vertical reinforcing bars with a hooked end that is placed on each side of the opening to restrain the lintel against uplift forces in high-hazard wind or earthquake regions. Building codes typically require steel lintels exposed to the exterior to be a

minimum 1/4-inch thick. Figure 4.8 illustrates some lintels commonly used in residential masonry construction.

FIGURE 4.8 *Concrete Masonry Wall Lintel Types*

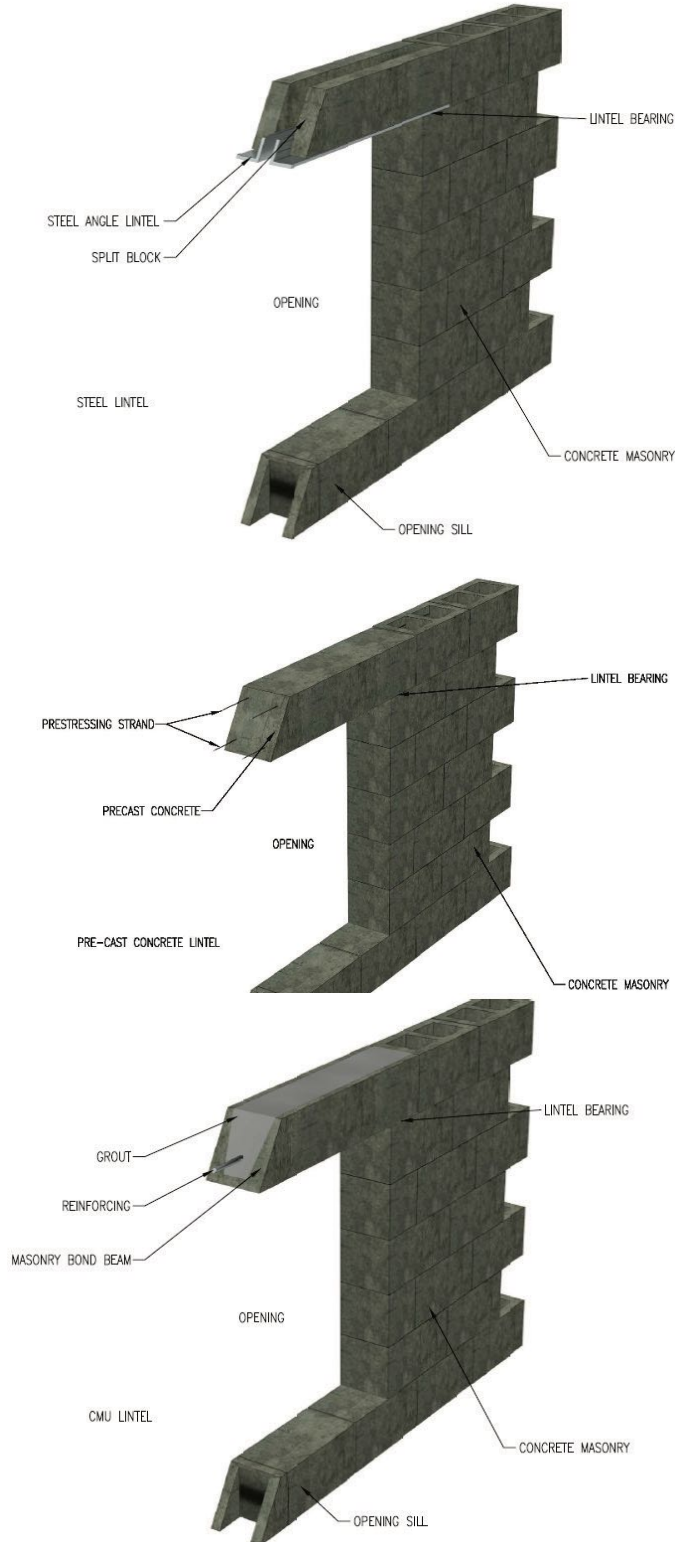

Many prescriptive design tables are available for lintel design. For more information on lintels, arches, and their design, refer to the National Concrete Masonry Association's (NCMA's) TEK Notes. Information on lintels and arches also can be found in *Masonry Design and Detailing* (Beall, 2012).

4.5.3 Preservative-Treated Wood Foundation Walls

Preservative-treated wood foundations, commonly known as permanent wood foundations (PWF), have been used in more than 300,000 homes and other structures throughout the United States. When properly installed, they provide foundation walls at an affordable cost. In some cases, the manufacturer may offer a 50-year material warranty, which exceeds the warranty offered for other common foundation materials.

A PWF is a load-bearing, preservative-treated, wood-framed foundation wall sheathed with preservative-treated plywood; it bears on a gravel spread footing. PWF lumber and plywood used in foundations are pressure treated with chromated copper arsenate (CCA) or other approved preservatives (AWPA, 2013). The walls are supported laterally at the top by the floor system and at the bottom by a cast-in-place concrete slab, a pressure-treated lumber floor system, or backfill on the inside of the wall. Proper connection details are essential, along with provisions for drainage and moisture protection. All fasteners and hardware used in a PWF should be stainless steel or hot-dipped galvanized steel. Figure 4.9 illustrates a PWF.

PWFs may be designed in accordance with the basic provisions in the IRC (ICC, 2012). Those provisions, in turn, are based on the American Forest and Paper Association's *Permanent Wood Foundation Design Specification* (AF&PA, 2007). The PWF guide offers design flexibility and thorough technical guidance. Table 4.7 summarizes some basic rules of thumb for design, and the steps for using the prescriptive tables follow.

FIGURE 4.9

Preservative-Treated Wood Foundation Walls

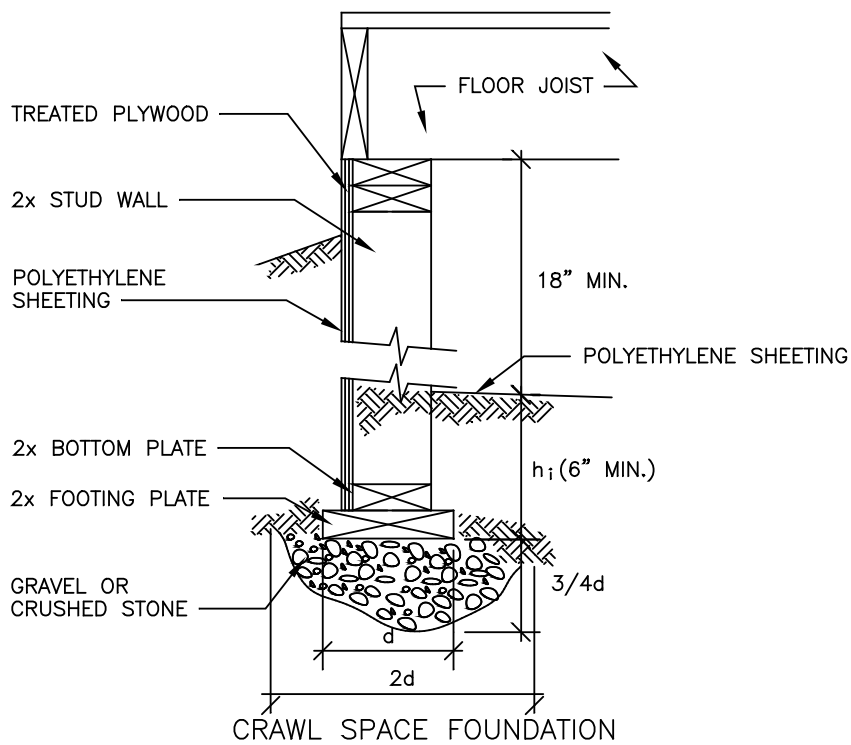
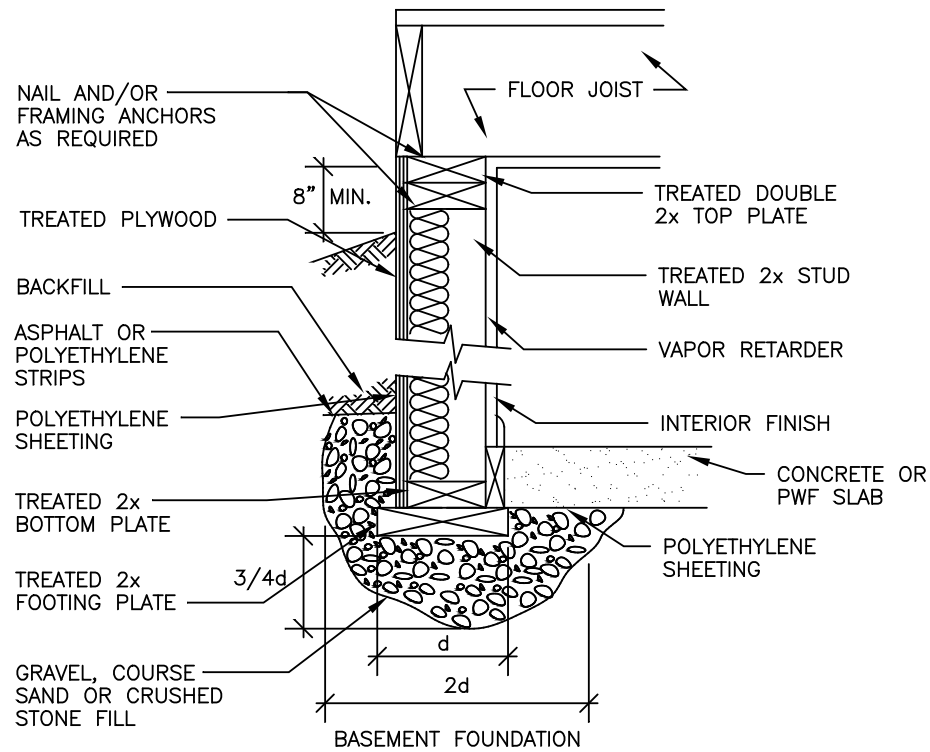

TABLE 4.8***Preservative-Treated Wood Foundation Framing¹***

Maximum Unbalanced Backfill Height (feet)	Nominal Stud Size	Stud Center-to-Center Spacing (inches)
5	2x6	16
6	2x6	12
8	2x8	12

- Connect each stud to top plate with framing anchors when the backfill height is 6 feet or greater.
- Provide full-depth blocking in the outer joist space along the foundation wall when floor joists are oriented parallel to the foundation wall.
- The bottom edge of the foundation studs should bear against a minimum of 2 inches of the perimeter screed board or the basement floor to resist shear forces from the backfill.

¹Connection of studs to plates and plates to floor framing is critical to the performance of permanent wood foundations. The building code and the *Permanent Wood Foundation Design Specification* (AF&PA, 2007) should be carefully consulted with respect to connections.

- Granular (that is, gravel or crushed rock) footings are sized in accordance with section 4.4.1. Permanent wood foundations may also be placed on poured concrete footings.
- Footing plate size is determined by the vertical load from the structure on the foundation wall and the size of the permanent wood foundation studs.
- The size and spacing of the wall framing is selected from tables for buildings up to 36 feet wide that support one or two stories above grade.
- APA-rated plywood is selected from tables based on unbalanced backfill height and stud spacing. The plywood must be treated with preservatives and rated for below-ground application.
- Drainage systems are selected in accordance with foundation type (for example, basement or crawl space) and soil type. Foundation wall moisture proofing (that is, polyethylene sheeting) also is required.

For more information on preservative-treated wood foundations and their specific design and construction, consult the *Permanent Wood Foundation Specification* (AF&PA, 2007).

4.5.4 Insulating Concrete Form Foundation Walls

Insulating concrete forms (ICFs) have been used in the United States since the 1970s. They provide durable and thermally efficient foundation and above-grade walls at reasonable cost. ICFs are constructed of rigid foam plastic, composites of cement and plastic foam insulation or wood chips, or other suitable insulating materials that have the ability to act as forms for cast-in-place concrete walls. The forms are easily placed by hand and remain in place after the concrete is cured to provide added insulation.

ICF systems typically are categorized with respect to the form of the ICF unit. There are three types of ICF forms: hollow blocks, planks, and panels. The shape of the concrete wall is best visualized with the form stripped away, exposing the concrete to view. Following are the ICF categories based on the resulting nature of the concrete wall.

- *Flat.* Solid concrete wall of uniform thickness.
- *Post-and-beam.* Concrete frame constructed of vertical and horizontal concrete members with voids between the members created by the form. The spacing of the vertical members may be as great as 8 feet.
- *Screen-grid.* Concrete wall composed of closely spaced vertical and horizontal concrete members with voids between the members created by the form. The wall resembles a thick screen made of concrete.
- *Waffle-grid.* Concrete wall composed of closely spaced vertical and horizontal concrete members with thin concrete webs filling the space between the members. The wall resembles a large waffle made of concrete.

Foundations may be designed in accordance with the values provided in the most recent national building codes' prescriptive tables (ICC, 2012). Manufacturers also usually provide design and construction information. ICF walls are designed by following a procedure similar to that in section 4.5.1; however, special consideration must be given to the dimensions and shape of an ICF wall that is not a flat concrete wall (refer to figure 4.10 for a typical ICF foundation wall detail).

FIGURE 4.10 *Insulating Concrete Form Foundation Walls*

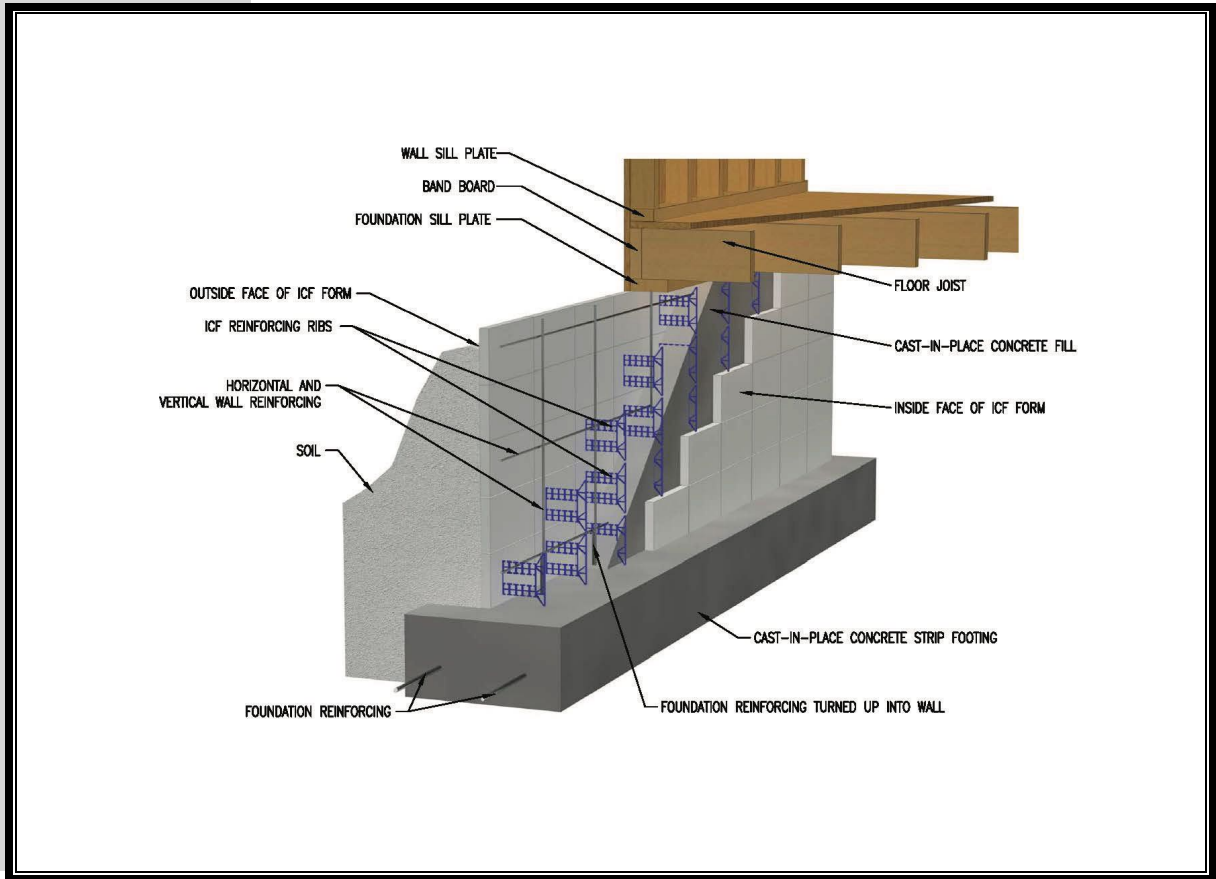

For more design information, consult the *Prescriptive Design of Exterior Concrete Walls for One- and Two-Family Dwellings* (PCA-100, 2007) or the *Prescriptive Method for Insulating Concrete Forms in Residential Construction* (HUD, 2002).

4.6 Slabs on Grade

The primary objectives of slab-on-grade design are—

- To provide a floor surface with adequate capacity to support all applied loads.
- To provide thickened footings for attachment of the above-grade structure and for transfer of the load to the earth where required.
- To provide a moisture barrier between the earth and the interior of the building.

Many concrete slabs for homes, driveways, garages, and sidewalks are built according to standard thickness recommendations and do not require a

specific design unless poor soil conditions, such as expansive clay soils, exist on the site.

For typical loading and soil conditions, floor slabs, driveways, garage floors, and residential sidewalks are built at a nominal 4 inches thick per ACI 302•2.1. Where interior columns and load-bearing walls bear on the slab, the slab typically is thickened and may be nominally reinforced (refer to section 4.4 for footing design procedures). Monolithic slabs may also have thickened edges that provide a footing for structural loads from exterior load-bearing walls. The thickened edges may or may not be reinforced in accordance with the loads and the soil-bearing capacity.

Slab-on-grade foundations often are placed on 2 to 3 inches of washed gravel or sand and a 6-mil (0.006 inch) polyethylene vapor barrier. This recommended practice prevents moisture in the soil from wicking through the slab. The sand or gravel layer acts primarily as a capillary break to soil moisture transport through the soil. If tied into the foundation drain system, the gravel layer also can help provide drainage.

A slab-on-grade greater than 10 feet in any dimension will likely experience cracking from temperature and shrinkage effects that create internal tensile stresses in the concrete. To prevent the cracks from becoming noticeable, the designer usually specifies reinforcement, such as welded wire fabric (WWF) or a fiber-reinforced concrete mix. The location of cracking may be controlled by placing construction joints in the slab at regular intervals or at strategic locations hidden under partitions or under certain floor finishes (that is, carpet).

In poor soils in which reinforcement is required to increase the slab's flexural capacity, the designer should follow conventional reinforced concrete design methods. The Portland Cement Association, Wire Reinforcement Institute (WRI), and U.S. Army Corps of Engineers (USACE) each espouse a different method for the design of plain or reinforced concrete slabs-on-grade.

Presented in chart or tabular format, the PCA method selects a slab thickness in accordance with the applied loads and is based on the concept of one equivalent wheel loading at the center of the slab. PCA design typically does not require structural reinforcement; however, a nominal amount of reinforcement is suggested for minimizing cracks, shrinkage, and temperature effects.

The WRI method selects a slab thickness in accordance with a discrete-element computer model for the slab. The approach graphically accounts for the relative stiffness between grade support and the concrete slab to determine moments in the slab and presents the information in the form of design nomographs.

Presented in charts and tabular format, the USACE method is based on Westergaard's (1926) formulae for edge stresses in a concrete slab. This method assumes that the unloaded portions of the slab help support the slab portions under direct loading.

For further information on the design procedures for each design method mentioned and for unique loading conditions, refer to ACI 360, *Guide to Design of Slabs on Ground* (ACI, 2010), or *Design and Construction of Post-Tensioned Slabs on Ground* (PTI, 2008) for expansive soil conditions.

4.7 Pile Foundations

Piles support buildings under a variety of special conditions that make conventional foundation practices impractical or inadvisable. Such conditions include—

- Weak soils or nonengineered fills that require the use of piles to transfer foundation loads by skin friction or point bearing.
- Inland floodplains and coastal flood hazard zones where buildings must be elevated.
- Steep or unstable slopes.
- Expansive soils on which buildings must be isolated from soil expansion in the “active” surface layer and anchored to stable soil below.

Piles are available in a variety of materials and different mechanisms of support. Preservative-treated timber piles typically are driven into place by a crane with a mechanical or drop hammer (most common in weak soils and coastal construction). Concrete piles or piers typically are cast in place in drilled holes, sometimes with “belled” bases (most common in expansive soils). Steel H-piles or large-diameter pipes are typically driven or vibrated into place with specialized heavy equipment (uncommon in residential construction). Helical piles have screw flights on the end that are “screwed” into the ground until they reach refusal. They most often terminate in a concrete grade beam to tie the tops of the piles together, thereby reducing lateral movement of the foundation system.

Timber piles most commonly are used in light-frame residential construction. The minimum pile capacity is based on the required foundation loading. Pile capacity is, however, difficult to predict; therefore, designers are able to make only rough estimates of required pile lengths and sizes before installation, particularly when the designer relies only on skin friction to develop capacity in deep, soft soils. For this reason, being familiar with local successful practice is a factor in any pile foundation design. A pile foundation sometimes can be specified by drawing on experience, with minimal design effort, in locations not subject to flooding or other extreme loadings from high winds or earthquakes. In other cases, some amount of subsurface exploration (that is, by using a standard penetrometer test) is advisable to assist in foundation design or, alternatively, to indicate when one or more test piles may be required.

Pile depth rarely has to be greater than 8 or 10 feet except in extremely soft soils, on steeply sloped sites with unstable soils, or in coastal hazard areas (that is, beachfront property) where significant scour is possible from storm surge velocity. Under these conditions, depths can easily exceed 15 feet and often reach 25 feet. In coastal high-hazard areas known as “V zones” on flood insurance rating maps (FIRMs), the building must be elevated above the 100-year flood elevation, which is known as the base flood elevation (BFE) and includes an

allowance for wave height. Figure 4.11 shows how treated timber piles typically are used to elevate a structure.

FIGURE 4.11 *Basic Coastal Foundation Construction*

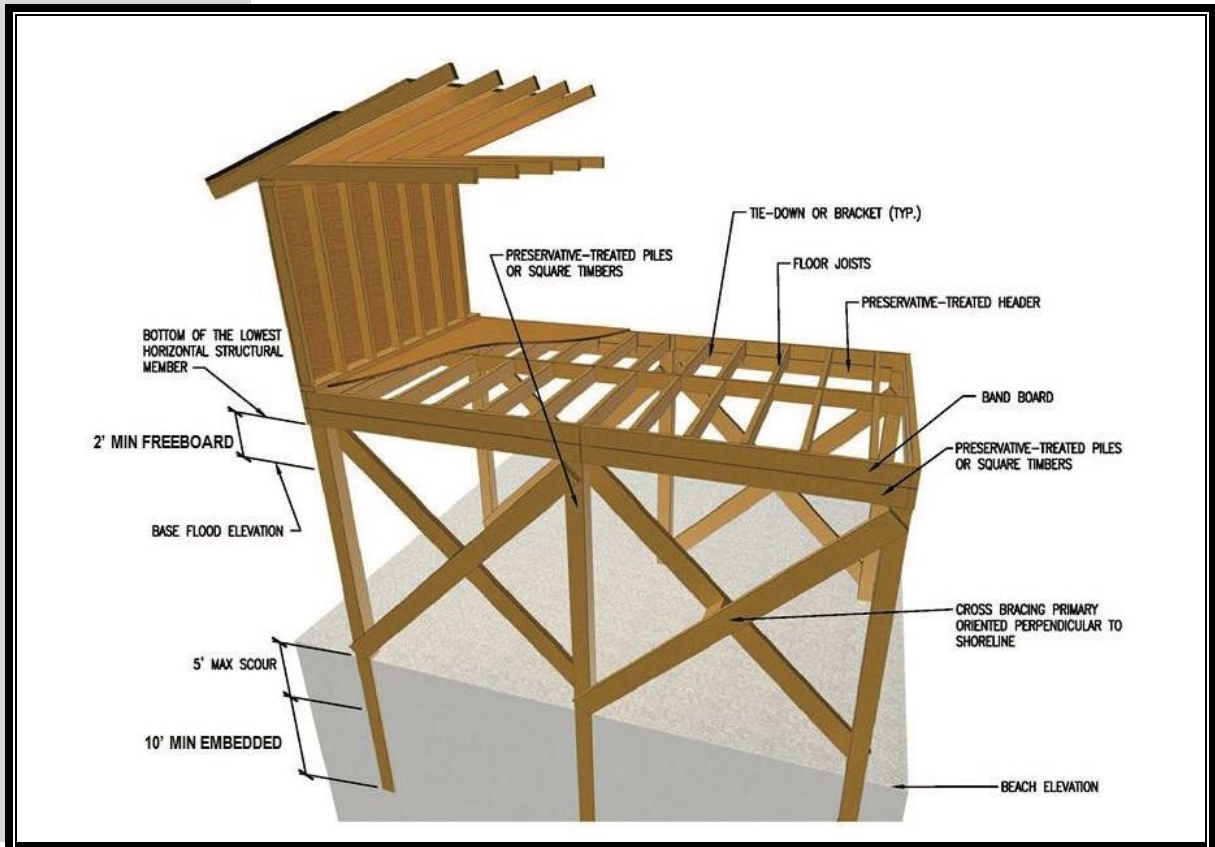

For additional guidance, the designer should refer to the *Coastal Construction Manual, FEMA P-55* (FEMA, 2011a) and *Home Builder's Guide to Coastal Construction, FEMA P-499* (FEMA, 2011b), both of which are updated frequently by the Federal Emergency Management Agency (FEMA). Another helpful resource is *Pile Driving by Pile Buck* (Pile Buck, 2011). Of course, designers should be prepared to make reasonable design modifications and judgments based on personal experience with and knowledge of pile construction and local conditions. The designer should also carefully consider National Flood Insurance Program (NFIP) requirements because they may affect the availability and cost of insurance. From a life-safety perspective, people often evacuate pile-supported buildings during a major hurricane, but flood damage can be substantial if the building is not properly elevated and detailed. In these conditions, the designer must consider several factors, including flood loads, wind loads, scour, breakaway wall and slab construction, corrosion, and other factors.

The habitable portion of buildings in coastal “A zones” (nonvelocity flow) and inland floodplains must be elevated above the BFE, particularly if owners

will be seeking flood insurance. Piles or other forms of an open foundation are the recommended method for constructing a foundation in coastal “A zones.”

The designer must specify a required minimum penetration length and the required axial capacity so the installer can equate driving resistance to sufficient bearing capacity. The designer should use pile capacity formulas such as those provided by the Navy guide titled *Foundations and Earth Structures, Design Manual 7.02* (NAVFAC, 1986). The pile size may be specified as a minimum tip diameter, a minimum butt diameter, or both. The minimum pile butt diameter should be no less than 8 inches; 10- to 12-inch diameters are common. The larger pile diameters may be necessary for unbraced conditions with long, unsupported heights.

In hard material or densely compacted sand or hard clay, a typical pile meets “refusal” when the blows per foot become excessive. In such a case, the builder may need to jet or predrill the pile to a specific depth to meet the minimum embedment and then finish with several hammer blows to ensure that the required capacity is met and the pile properly seated in firm soil. When using either jetting or drilling as an installation method, the designer must consider reducing the capacity of the pile.

Jetting is the process of using a water pump, hose, and long pipe to “jet” the tip of the pile into hard-driving ground, such as firm sand. Jetting may also be used to adjust the pile vertically to maintain a reasonable tolerance with the building layout dimension.

Connecting or anchoring the building properly to pile foundations is important when severe uplift or lateral load conditions are expected. For standard pile and concrete grade beam construction, the pile is usually extended into the concrete “cap” a few inches or more. The connection requirements of the *National Design Specification for Wood Construction* (NDS; AWC, 2012) should be carefully followed for these heavy-duty connections. Such connections are not specifically addressed in chapter 7, although much of the information in that chapter is applicable to the topic.

4.8 Frost Protection

The objective of frost protection in foundation design is to prevent damage to the structure from frost action (that is, heaving and thaw weakening) in frost-susceptible soils.

4.8.1 Conventional Methods

In northern U.S. climates, builders and designers mitigate the effects of frost heave by constructing homes with perimeter footings that extend below a locally prescribed frost depth. Other construction methods include—

- Piles or caissons extending below the seasonal frost line.

- Mat or reinforced structural slab foundations that resist differential heave.
- Non-frost-susceptible fills and drainage.
- Adjustable foundation supports.

The local building department typically sets required frost depths. Often, the depths set for residential foundations are highly conservative compared with frost depths relevant to other applications. The local design frost depth can vary significantly from that required by actual climate, soil, and application conditions. One exception occurs in Alaska, where it is common to specify different frost depths for “warm,” “cold,” and “interior” foundations. For homes in the Anchorage, Alaska, area, the perimeter foundation generally is classified as warm, with a required frost depth of 4 to 5 feet. Interior footings may be required to be 8 inches deep. On the other hand, frost depth requirements for cold foundations, including outside columns, may be as much as 10 feet. In the contiguous 48 states, depths for footings range from a minimum 12 inches in the South to as much as 6 feet or more in some northern localities.

Based on the air-freezing index, table 4.8 presents minimum “safe” frost depths for residential foundations. Figure 4.12 depicts the air-freezing index, a climate index closely associated with ground freezing depth. The most frost-susceptible soils are silty soils, or mixtures that contain a large fraction of silt-sized particles. Generally, soils or fill materials with less than 6 percent fines (as measured by a #200 sieve) are considered non-frost-susceptible. Proper surface water and foundation drainage also are important factors where frost heave is a concern. The designer should recognize that many soils may not be frost susceptible in their natural state (such as sand, gravel, or other well-drained soils that are typically low in moisture content). For those soils that are frost susceptible, however, the consequences can be significant and costly if not properly considered in the foundation design.

TABLE 4.9 *Minimum Frost Depths for Residential Footings^{1,2}*

Air-Freezing Index (°F-Days)	Footing Depth (inches)
250 or less	12
500	18
1,000	24
2,000	36
3,000	48
4,000	60

¹Interpolation is permissible.

²The values do not apply to mountainous terrain or to Alaska.

4.8.2 Frost-Protected Shallow Foundations

A frost-protected shallow foundation (FPSF) is a practical alternative to deeper foundations in cold regions characterized by seasonal ground freezing and the potential for frost heave. Figure 4.13 illustrates several FPSF applications. FPSFs are best suited to slab-on-grade homes on relatively flat sites. The FPSF method may be used effectively with walkout basements, however, by insulating the foundation on the downhill side of the house, thus eliminating the need for a stepped footing

An FPSF is constructed by using strategically placed vertical and horizontal insulation to insulate the footings around the building, thereby allowing foundation depths as shallow as 12 inches in very cold climates. FPSF technology recognizes earth as a heat source that repels frost. Heat input to the ground from buildings therefore contributes to the thermal environment around the foundation.

The thickness of the insulation and the horizontal distance that the insulation must extend away from the building depends primarily on the climate. In less severe cold climates, horizontal insulation is not necessary. Other factors such as soil thermal conductivity, soil moisture content, and the internal temperature of a building are also important determinants of insulation use. Current design and construction guidelines are based on reasonable worst-case conditions.

After more than 40 years of use in the Scandinavian countries, FPSFs are now recognized in the prescriptive requirements of the IRC (ICC, 2012); however, the code places limits on the use of foam plastic below grade in areas of noticeably high termite infestation probability. In those areas, termite barriers or other modifications must be incorporated into the design to block “hidden” pathways leading from the soil into the structure between the foam insulation and the foundation wall. The exception to the code limit occurs when termite-resistant materials (for example, concrete, steel, or preservative-treated wood) are specified for a home’s structural members.

FIGURE 4.12 *Air-Freezing Index Map (100-Year Return Period)*

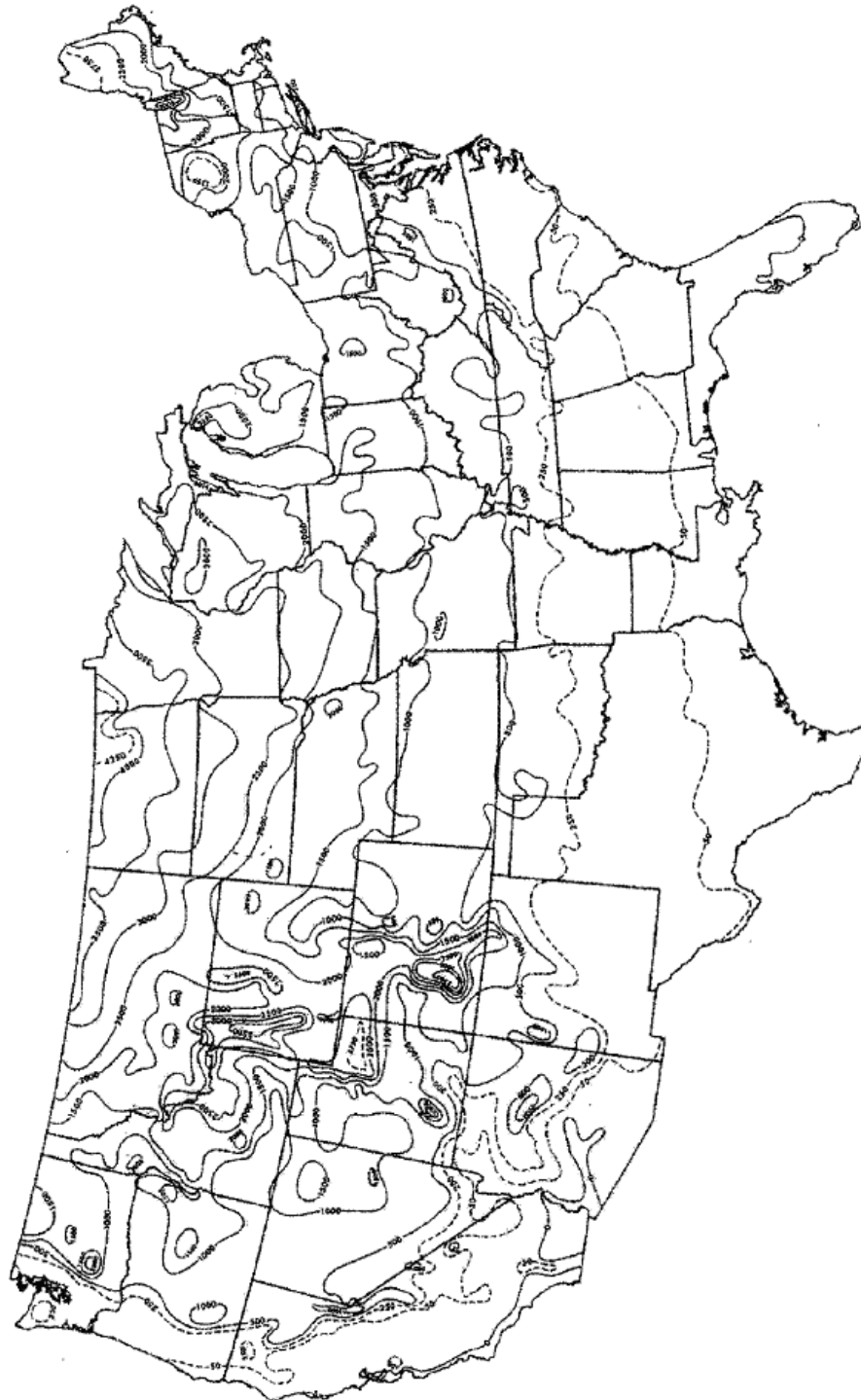

Source: Reprinted with permission from the International Code Council, Washington, D.C. Copyright ICC.

Note: The air-freezing index is defined as the number of cumulative degree days below 32°F and is a measure of the magnitude and duration of below freezing air temperatures.

The complete design procedure for FPSFs is detailed in *Frost Protected Shallow Foundations in Residential Construction, Second Edition* (NAHB, 1996). The first edition of this guide is available from the U.S. Department of Housing and Urban Development. Either version provides useful construction details and guidelines for determining the amount (thickness) of insulation required for a given climate or application. Acceptable insulation materials include expanded and extruded polystyrenes, although adjusted insulation values are provided for below-ground use.

The American Society of Civil Engineers also has a standard for FPSF design and construction based on the resources mentioned. This standard is titled *Design Guide for Frost-Protected Shallow Foundations, ASCE 32-01* (ASCE, 2001).

FIGURE 4.13

Frost-Protected Shallow Foundation Applications

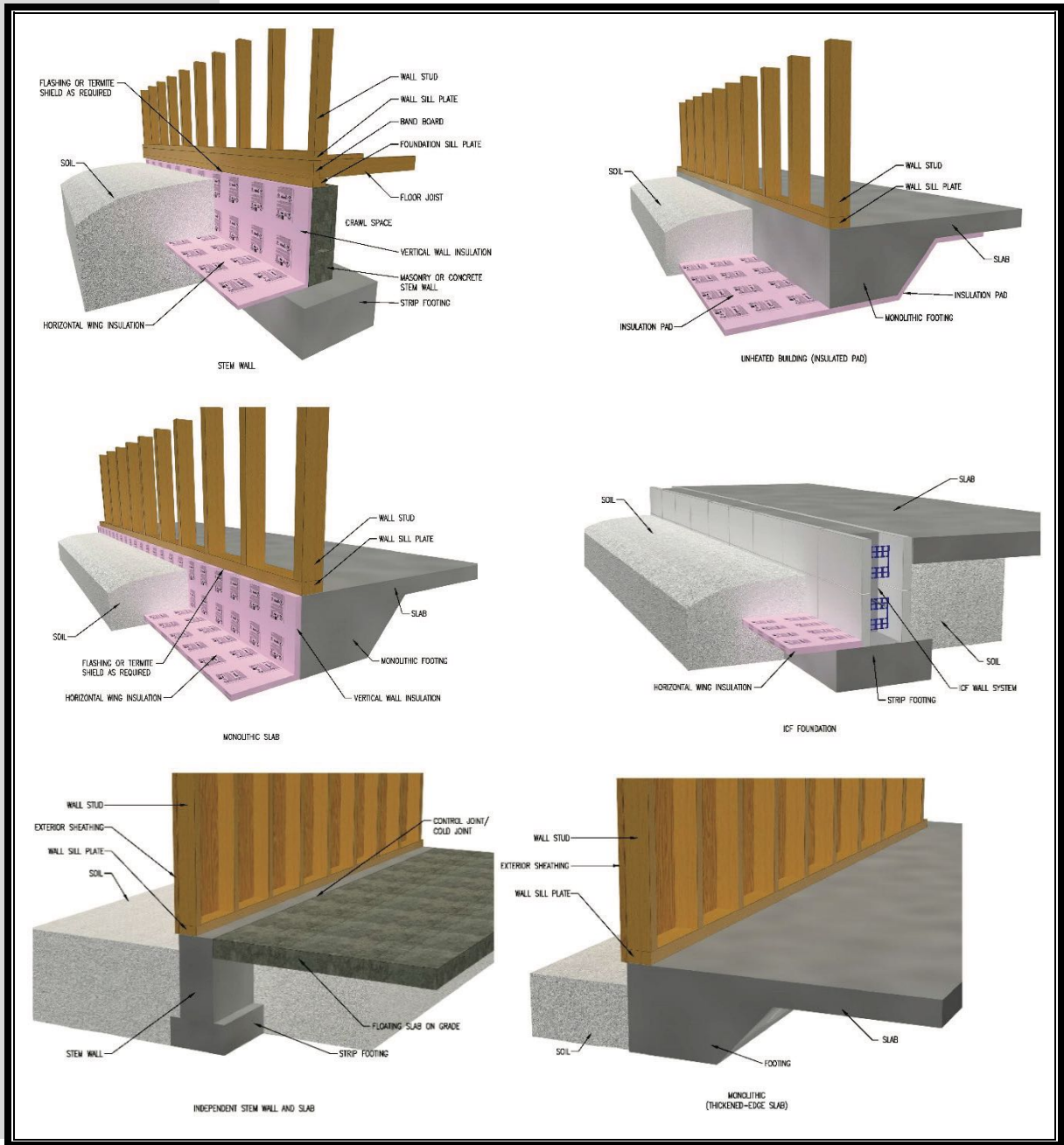

4.9 Design Examples

EXAMPLE 4.1

Plain Concrete Footing Design

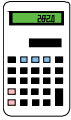

Given

Exterior continuous wall footing supporting an 8-inch-wide concrete foundation wall carrying a 12-foot floor tributary width; the wall supports two floor levels, each with the same tributary width.

Design Loads

$$\begin{aligned}\text{Live load} &= 0.75 [(12 \text{ ft})(40 \text{ psf}) + (12 \text{ ft})(30 \text{ psf})] = 630 \text{ plf} && \text{(Table 3.1)} \\ \text{Dead load} &= (12 \text{ ft})(10 \text{ psf})(2 \text{ floors}) = 240 \text{ plf} && \text{(Table 3.2)} \\ \text{Wall dead load} &= (8 \text{ ft})(0.66 \text{ ft})(150 \text{ pcf}) = 800 \text{ plf} && \text{(Table 3.3)} \\ \text{Footing dead load allowance} &= 200 \text{ plf}\end{aligned}$$

$$\begin{aligned}\text{Presumptive soil-bearing capacity} &= 1,500 \text{ psf (default)} \\ f'_c &= 2,000 \text{ psi}\end{aligned}$$

Find

The minimum size of the concrete footing required to support the loads

Solution

1. Determine the required soil-bearing area.

$$\text{Footing width} = \frac{\text{Design load}}{\text{Soil bearing}} = \frac{(630 + 240 + 800 + 200 \text{ plf})(1 \text{ ft})}{1,500 \text{ psf}} = 1.25 \text{ ft}$$

The required footing width is equal to

$$b = 1.25 \text{ ft} = 15 \text{ in} \cong 16 \text{ in (standard width of excavation equipment)}$$

2. Preliminary design (rule-of-thumb method)

$$\text{Footing projection} = 1/2 (16 \text{ in} - 8 \text{ in}) = 4 \text{ in}$$

Required plain concrete footing thickness $\cong 4$ in (no less than the projection)
 \therefore Use minimum 6-inch-thick footing.

$$\text{Footing weight} = (1.33 \text{ ft})(0.5 \text{ ft})(150 \text{ pcf}) = 100 \text{ lb} < 200 \text{ lb allowance OK}$$

Consider design options.

3.
 - Use 6-inch x 16-inch plain wall concrete footing.
 - Design plain concrete footing to check rule of thumb for illustrative purposes only.

Design a plain concrete footing.

(a) Determine soil pressure based on factored loads.

$$q_s = \frac{P_u}{A_{\text{footing}}} = \frac{(1.2)(240 \text{ plf} + 800 \text{ plf} + 200 \text{ plf}) + (1.6)(630 \text{ plf})}{(1.33 \text{ ft})(1 \text{ ft})} = 1,877 \text{ psf}$$

(b) Determine thickness of footing based on moment at the face of the wall.

$$M_u = \frac{q_s \ell}{8} (b - T)^2$$

$$= \frac{(1,877 \text{ psf})(1 \text{ ft})}{8} (1.33 \text{ ft} - 0.66 \text{ ft})^2 = 105 \text{ ft} \cdot \text{lb} / \text{lf}$$

$$\phi M_n = 5\sqrt{f'_c} S = 5\sqrt{2,000 \text{ psi}} \frac{b t^2}{6}$$

$$\phi M_n \geq M_u$$

$$(105 \text{ ft} \cdot \text{lb} / \text{lf})(12 \text{ in} / \text{ft}) \geq (0.65)(5)\left(\sqrt{2,000 \text{ psi}}\right)\left(\frac{(12 \text{ in}) t^2}{6}\right)$$

$$t = 2.1 \text{ in}$$

(c) Determine footing thickness based on one-way (beam) shear.

$$\phi V_c = \phi \frac{4}{3} \sqrt{f'_c} \ell t$$

$$= 0.65 \left(\frac{4}{3}\right) \sqrt{2,000 \text{ psi}} (12 \text{ in})(t)$$

$$V_u = (q_s \ell)(0.5(b - T) - t)$$

$$= (1,849 \text{ psf})(1 \text{ ft})(0.5(1.33 \text{ ft} - 0.66 \text{ ft}) - t)$$

$$\phi V_c \geq V_u$$

$$0.65 \left(\frac{4}{3}\right) \sqrt{2,000 \text{ psi}} (12 \text{ in})(t) = (1,877 \text{ psf})(1 \text{ ft})(0.5(1.33 \text{ ft} - 0.66 \text{ ft}) - t)$$

$$t = 0.27 \text{ ft} = 3.2 \text{ in}$$

Therefore, shear in the footing governs the footing thickness.

Conclusion The calculations yield a footing thickness of 3.2 inches. In accordance with ACI 318•22.4.8, two additional inches must be added, resulting in a footing thickness of 5.2 inches. In accordance with ACI 318•22.7.4, however, plain concrete footings may not have a thickness less than 8 inches. In this case, a more economical and code-compliant footing design (6 inches thick) can be achieved by following the IRC prescriptive provisions for footings rather than following ACI provisions.

In high-hazard seismic areas, a nominal footing reinforcement should be considered (for example, one No. 4 bar longitudinally); however, longitudinal reinforcement at the top and bottom of the foundation wall provides greater strength against differential soil movement in a severe seismic event, particularly on sites with soft soils.

EXAMPLE 4.2
Reinforced Footing Design

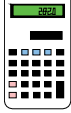
	Given	<p>Interior footing supporting a steel pipe column (3.5 in x 3.5 in bearing) carrying a 12-ft x 12-ft floor tributary area</p> <p>Service Loads</p> <p>Live load (12 ft)(12 ft)(40 psf) = 5,760 lb Dead load (12 ft)(12 ft)(10 psf) = 1,440 lb Footing and column dead load = 300 lb (allowance)</p> <p>Presumptive soil bearing capacity = 1,500 psf (default) $f'_c = 2,500$ psi, $f_y = 60,000$ psi</p>
	Find	The minimum size of the concrete footing required to support the loads
	Solution	
	1.	<p>Determine the required soil-bearing area.</p> $\text{Area required} = \frac{\text{Service load}}{\text{Presumptive soil bearing}} = \frac{(5,760 \text{ lb} + 1,440 \text{ lb} + 300 \text{ lb})}{1,500 \text{ psf}} = 5 \text{ ft}^2$ <p>Assume a square footing</p> $b = \sqrt{5 \text{ ft}^2} = 2.2 \text{ ft} = 26 \text{ in}$
	2.	<p>Preliminary design (rule-of-thumb method)</p> <p>Footing projection = $1/2 (26 \text{ in} - 3.5 \text{ in}) = 11.25 \text{ in}$</p> <p>$\therefore$ Required plain concrete footing thickness $\cong 12 \text{ in}$</p> <p>Footing weight = $(5 \text{ ft}^2)(1 \text{ ft})(150 \text{ pcf}) = 750 \text{ lb} > 300 \text{ lb}$ allowance</p> <p>\therefore Recalculation yields a 28-in x 28-in footing.</p>
	3.	<p>Consider design options.</p> <ul style="list-style-type: none"> • Use 12-in x 28-in x 28-in plain concrete footing (5 ft³ of concrete per footing, less expensive). • Reduce floor column spacing (more but smaller footings, perhaps smaller floor beams, more labor). • Test soil bearing to see if higher bearing value is feasible (uncertain benefits, but potentially large, perhaps one-half reduction in plain concrete footing size). • Design a plain concrete footing to determine if a thinner footing is feasible • Design thinner, reinforced concrete footing (tradeoff with material and labor).
	4.	<p>Design a reinforced concrete footing.</p> <p>Given Square footing, 28 in x 28 in $f'_c = 2,500$ psi concrete; 60,000 psi steel</p> <p>Find Footing thickness and reinforcement</p>

		<p>(a) Select trial footing thickness, rebar size, and placement.</p> $\begin{aligned} t &= 6 \text{ in} \\ c &= 3 \text{ in} \\ d_b &= 0.5 \text{ in (No. 4 rebar)} \end{aligned}$ <p>(b) Calculate the distance from extreme compression fiber to centroid of reinforcement d.</p> $\begin{aligned} d &= t - c - 0.5d_b \\ &= 6 \text{ in} - 3 \text{ in} - 0.5(0.5 \text{ in}) \\ &= 2.75 \text{ in} \end{aligned}$ <p>(c) Determine soil pressure based on factored load.</p> $q_s = \frac{P_u}{A_{\text{footing}}} = \frac{(1.2)(1,440 \text{ lb} + 300 \text{ lb}) + (1.6)(5,760 \text{ lb})}{5 \text{ ft}^2} = 2,261 \text{ psf}$ <p>(d) Check one-way (beam) shear in footing for trial footing thickness.</p> $\phi V_c \gg V_u$ $V_u = \left(\frac{P_u}{b} \right) (0.5(b - T) - d) =$ $V_u = \left(\frac{11,304 \text{ lbs}}{28 \text{ in}} \right) (0.5(28 \text{ in} - 3.5 \text{ in}) - 2.75 \text{ in}) = 3,835 \text{ lbs}$ $\phi V_c \gg V_u \text{ OK}$ <p>(e) Check two-way (punching) shear in trial footing.</p> $\phi V_c > V_u$ $= (0.85)(4)\sqrt{2500} \text{ psi} (4(3.5 \text{ in} + 2.75 \text{ in}))(2.75 \text{ in}) = 11,688 \text{ lbs}$ $V_u = \left(\frac{P_u}{b^2} \right) (b^2 - (T + d)^2)$ $= \frac{11,304 \text{ lbs}}{(28 \text{ in})^2} ((28 \text{ in})^2 - (3.5 \text{ in} + 2.75 \text{ in})^2) = 10,741 \text{ lbs}$ <p>OK</p> <p>(f) Determine reinforcement required for footing, based on critical moment at edge of column.</p> <p>OK</p> <p>Use four No. 4 bars where $A_s = 4(0.2 \text{ in}^2) = 0.8 \text{ in}^2 \geq 0.77 \text{ in}^2$ OK</p>
	Conclusion	Use minimum 28-in x 28-in x 6-in footing with four No. 4 bars or three No. 5 bars each way in footing.

			$f_c = 2,500$ psi minimum (concrete) $f_y = 60,000$ psi minimum (steel reinforcing bar)
--	--	--	--

EXAMPLE 4.3
Plain Concrete Foundation Wall Design

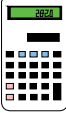
		Given	<p>Design loads</p> <p>Snow load (S) = 280 plf Live load (L) = 650 plf Dead load (D) = 450 plf Moment at top = 0 Concrete weight = 150 pcf Backfill material = 45 pcf f_c = 3,000 psi</p> <p>Wall thickness = 8 in Wall height = 8 ft Unbalanced backfill height = 7 ft</p> <p>Assume axial load is in middle one-third of wall.</p>
		Find	<p>Verify that an 8-inch-thick plain concrete wall is adequate for the following load combinations from chapter 3 (table 3.1).</p> <ul style="list-style-type: none"> • $1.2D + 1.6H$ • $1.2D + 1.6H + 1.6L + 0.5(L_r + S)$ • $1.2D + 1.6H = 1.6(L_r + S) + 0.5L$ <p>Only the first load combination will be evaluated because it can be shown to govern the wall design.</p>
		Solution	
		1.	<p>Determine loads.</p> <p>Equivalent fluid density of backfill soil</p> <p>Silty clay: $w = 100$ pcf, $K_a = 0.45$ (see section 3.5)</p> <p>$q = K_a w = (0.45)(100 \text{ pcf}) = 45$ pcf</p> <p>Total lateral earth load</p> $H = \frac{1}{2} q l^2 = \frac{1}{2} (45 \text{ pcf})(7 \text{ ft})^2 = 1,103 \text{ plf}$ $H = \frac{1}{2} q l^2 = \frac{1}{2} (45 \text{ pcf})(7 \text{ ft})^2 = 1,103 \text{ plf}$ $X_1 = \frac{1}{3} l = \frac{1}{3} (7 \text{ ft}) = 2.33 \text{ ft}$ <p>Maximum shear occurs at bottom of wall (see figure A.1 of appendix A)</p> $V_{\text{bottom}} = V_1 = \frac{1}{2} q h^2 \left(1 - \frac{h}{3L} \right) = \frac{1}{2} (45 \text{ pcf})(7 \text{ ft})^2 \left(1 - \frac{7 \text{ ft}}{3(8 \text{ ft})} \right) = 781 \text{ plf}$

		<p>Maximum moment and its location</p> $x = h - \sqrt{h^2 - \frac{2V_1}{q}}$ $= 7 \text{ ft} - \sqrt{(7 \text{ ft})^2 - \frac{2(781 \text{ plf})}{45 \text{ pcf}}}$ $= 3.2 \text{ ft from base of wall or 4.8 ft from top of wall}$ $M_{\max} (\text{at } x = 3.2 \text{ ft}) = V_1x - qhx^2 + qx^3$ $= (781 \text{ plf})(3.2 \text{ ft}) - (45 \text{ pcf})(7 \text{ ft})(3.2 \text{ ft})^2 + (45 \text{ pcf})(3.2 \text{ ft})^3$ $= 1,132 \text{ ft-lb/lf}$
	2.	<p>Check shear capacity.</p> <p>(a) Factored shear load</p> $V_u = 1.6 V_{\text{bottom}}$ $= 1.6 (781 \text{ plf}) = 1,250 \text{ plf}$ <p>(b) Factored shear resistance</p> $\phi V_n = \phi \frac{4}{3} \sqrt{f'_c} b h$ $= (0.65) \left(\frac{4}{3}\right) \sqrt{3,000 \text{ psi}} (8 \text{ in})(12 \text{ in}) = 4,557 \text{ plf}$ <p>(c) Check $\phi V_n \geq V_u$</p> $4,557 \text{ plf} \gg 1,250 \text{ plf} \text{ OK}$
	3.	<p>Check combined bending and axial load capacity.</p> <p>(a) Factored loads</p> $M_u = 1.6 M_{\max} = 1.6 (1,132 \text{ ft-lb/lf}) = 1,811 \text{ ft-lb/lf}$ $P_u = 1.2 D$ $D_{\text{structure}} = 450 \text{ plf (given)}$ $D_{\text{concrete@x}} = (150 \text{ plf}) \left(\frac{8 \text{ in}}{12 \text{ in/ft}}\right) (8 \text{ ft} - 3.23 \text{ ft}) = 480 \text{ plf}$ $D = 450 \text{ plf} + 480 \text{ plf} = 930 \text{ plf}$ $P_u = 1.2 (930 \text{ plf}) = 1,116 \text{ plf}$ <p>(b) Determine M_n, M_{\min}, P_u</p> $M_n = 0.85 f'_c S$ $S = \frac{1}{6} b d^2 = \left(\frac{1}{6}\right) (12 \text{ in})(8 \text{ in})^2 = 128 \text{ in}^3 / \text{lf}$ $M_n = 0.85 (3,000 \text{ psi})(128 \text{ in}^3/\text{lf}) = 326,400 \text{ in-lb/lf} = 27,200 \text{ ft-lb/lf}$ $M_{\min} = 0.1 h P_u = 0.1 \left(\frac{8 \text{ in}}{12 \text{ in/lf}}\right) (1,112 \text{ plf}) = 74 \text{ ft-lb/lf}$ $M_u > M_{\min} \text{ OK}$

			$P_n = 0.6f'_c \left[1 - \left(\frac{L}{32h} \right)^2 \right] A_g$ $= 0.6(3,000 \text{ psi}) \left[1 - \left(\frac{(8 \text{ ft})(12 \text{ in})}{32(8 \text{ in})} \right)^2 \right] (8 \text{ in})(12 \text{ in}) = 148,500 \text{ plf}$
		(c) Check combined bending and axial stress equations	<p>Compression</p> $\frac{P_u}{\phi P_n} + \frac{M_u}{\phi M_n} \leq 1$ $\frac{1,116 \text{ plf}}{(0.65)(148,500 \text{ plf})} + \frac{1,811 \text{ ft-lb/lf}}{(0.65)(27,200 \text{ ft-lb/lf})} \leq 1$ $0.11 \leq 1 \text{ OK}$ <p>Tension</p> $\frac{M_u}{S} - \frac{P_u}{A_g} \leq \phi 5\sqrt{f'_c} \frac{P_u}{\phi P_n} + \frac{M_u}{\phi M_n} \leq 1 \quad \frac{P_u}{\phi P_n} + \frac{M_u}{\phi M_n} \leq 1$ $\frac{M_u}{S} - \frac{P_u}{A_g} \leq \phi 5\sqrt{f'_c}$ $\frac{1,811 \text{ ft-lb/lf}(12 \text{ in/ft})}{128 \text{ in}^3/\text{lf}} - \frac{1,116 \text{ plf}}{(8 \text{ in})(12 \text{ in})} \leq (0.65)(5)\sqrt{3,000 \text{ psi}}$ $158 \leq 178 \text{ OK}$ <p>\therefore No reinforcement required</p>
	4.	Check deflection at mid-span (see figure A.1 in appendix A).	$= \frac{qL^3}{E_c I_g} \left[\frac{hL}{128} - \frac{L^2}{960} - \frac{h^2}{48} + \frac{h^3}{144L} \right]$ $\frac{(45 \text{ pcf})(8 \text{ ft})^3}{(3,122,019 \text{ psi}) \left(\frac{12 \text{ in}(8 \text{ in})^3}{12} \right)} \left[\frac{(7 \text{ ft})(8 \text{ ft})}{128} - \frac{(8 \text{ ft})^2}{960} - \frac{(7 \text{ ft})^2}{48} + \frac{(7 \text{ ft})^3}{144(8 \text{ ft})} \right] \left(\frac{1,728 \text{ in}^3}{\text{ft}^3} \right)$ $= 0.009 \text{ in/lf}$ $\Delta_{\text{all}} = \frac{L}{240} = \frac{(8 \text{ ft})(12 \text{ in/ft})}{240} = 0.4 \text{ in/lf}$ $\Delta_{\text{max}} \ll \Delta_{\text{all}} \text{ OK}$
	Conclusion	An 8-inch-thick plain concrete wall is adequate under the given conditions.	<p>The preceding analysis was performed for a given wall thickness. The same equations can be used to solve for the minimum wall thickness that satisfies the requirements for shear, combined bending and axial stress, and deflection. With this approach to the problem, the minimum thickness would be 7.6 inches (controlled by tensile stress under combined bending and axial load).</p>

		<p>In the strength-based design approach, the safety margin is related to the use of load and resistance factors. In this problem, the load factor was 1.6 (for a soil load, H) and the resistance factor 0.65 (for tensile bending stress). In terms of a traditional safety factor, an equivalent safety margin is found by $1.6/0.65 = 2.5$. It is a fairly conservative safety margin for residential structures and would allow for an equivalent soil fluid density of as much as 113 pcf ($45 \text{ pcf} \times 2.5$) at the point the concrete tensile capacity based on the minimum concrete compressive strength (as estimated by $5\sqrt{f'_c}$) is realized. This capacity would exceed loads that might be expected should the soil become saturated, which would occur under severe flooding on a site that is not well drained.</p> <p>The use of reinforcement varies widely as an optional enhancement in residential construction to control cracking and provide some nominal strength benefits. If reinforcement is used as a matter of good practice, one No. 4 bar may be placed as much as 8 feet on center. One horizontal bar may also be placed horizontally at the top of the wall and at mid-height.</p>
--	--	--

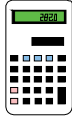
**Given**

Service loads

Live load (L)	= 1000 plf
Dead load (D)	= 750 plf
Moment at top	= 0
Concrete weight	= 150 pcf
Backfill material	= 60 pcf (equivalent fluid density)
Wall thickness	= 8 in
Wall height	= 10 ft
Unbalanced backfill height	= 8 ft
f'_c	= 3,000 psi
f_y	= 60,000 psi

Assume axial load is in middle one-third of wall.

Find

If one No. 5 bar at 24 inches on center vertically is adequate for the load combination, $U = 1.2D + 1.6H + 1.6L$ (chapter 3, table 3.1) when rebar is placed 3 inches from outer face of wall ($d=5$ in).

Solution

- Determine loads.

Total lateral earth load

$$H = \frac{1}{2}ql^2 = \frac{1}{2}(60 \text{ pcf})(8 \text{ ft})^2 = 1,920 \text{ plf}$$

$$X = \frac{1}{3}l = \frac{1}{3}(8 \text{ ft}) = 2.67 \text{ ft}$$

Maximum shear occurs at bottom of wall.

$$\begin{aligned} \sum M_{\text{top}} &= 0 \\ V_{\text{bottom}} &= \frac{H(L-x)}{L} = \frac{(1,920 \text{ plf})(10 \text{ ft} - 2.67 \text{ ft})}{10 \text{ ft}} = 1,408 \text{ plf} \end{aligned}$$

Maximum moment and its location

$$\begin{aligned} X_{\text{max}} &= \frac{ql - \sqrt{q^2l^2 - 2qV_{\text{bottom}}}}{q} \\ &= \frac{(60 \text{ pcf})(8 \text{ ft}) - \sqrt{(60 \text{ pcf})^2(8 \text{ ft})^2 - 2(60 \text{ pcf})(1,408 \text{ plf})}}{60 \text{ pcf}} \\ &= \\ X_{\text{max}} &= 3.87 \text{ ft from base of wall or 6.13 ft from top of wall} \end{aligned}$$

$$\begin{aligned}
 M_{\max} &= \frac{-q l x_{\max}^2}{2} + \frac{q x_{\max}^3}{6} + V_{\text{bottom}} (x_{\max}) \\
 &= \frac{-(60 \text{ pcf})(8 \text{ ft})(3.87 \text{ ft})^2}{2} + \frac{(60 \text{ pcf})(3.87 \text{ ft})^3}{6} + (1,408 \text{ plf})(3.87 \text{ ft}) \\
 &= 2,434 \text{ ft-lb/lf}
 \end{aligned}$$

2. Check shear capacity, assuming no shear reinforcement is required ($V_s=0$).

(a) Factored shear load

$$\begin{aligned}
 V_u &= 1.6 V_{\text{bottom}} \\
 &= 1.6 (1,408 \text{ plf}) = 2,253 \text{ plf}
 \end{aligned}$$

(b) Factored shear resistance

$$\begin{aligned}
 \phi V_n &= \phi (V_c + V_s) \\
 &= \phi (2) \sqrt{f'_c} b_w d \\
 &= (0.85) (2) \sqrt{3,000 \text{ psi}} (12 \text{ in}) (5 \text{ in}) = 5,587 \text{ plf}
 \end{aligned}$$

(c) Check $\phi V_n \geq V_u$

$$5,587 \text{ plf} \gg 2,253 \text{ plf OK}$$

3. Determine slenderness.

All four foundation walls are concrete with few openings; therefore, the system is a nonsway frame. This is a standard assumption for residential concrete foundation walls.

$$\begin{aligned}
 \text{Slenderness} \quad r &= \sqrt{\frac{I_g}{A_g}} = \sqrt{\frac{\left(\frac{1}{12}\right) (12 \text{ in}) (8 \text{ in})^3}{(8 \text{ in})(12 \text{ in})}} = 2.31 \\
 \frac{kl_u}{r} &< 34
 \end{aligned}$$

$$\frac{(1)(8 \text{ in})(12 \text{ in})}{2.31} = 41.6 \geq 34 \therefore \text{Use}$$

moment magnifier method

4. Determine the magnified moment using the moment magnifier method.

$$P_u = 1.2D + 1.6L = 1.2 (750 \text{ plf}) + 1.6 (1,000 \text{ plf}) = 2,500 \text{ plf}$$

Using the approximated moment magnifiers in table 4.4, the moment magnifier from the table for a 7.5-inch-thick wall, 10 feet high, is between 1.04 and 1.09. For a 9.5-inch-thick wall, the values are between 1 and 1.04.

Through interpolation, $\delta = 1.04$ for a 2,500 plf axial load.

5. Check pure bending.

$$a = \frac{A_s f_y}{0.85 f'_c b} = \frac{(0.155 \text{ in}^2)(60,000 \text{ psi})}{0.85 (3,000 \text{ psi})(12 \text{ in})} = 0.304$$

$$a =$$

$$\phi M_n = \phi A_s f_y \left(d - \frac{a}{2} \right)$$

$$= 0.9 (0.155 \text{ in}^2)(60,000 \text{ psi}) \left(5 \text{ in} - \frac{0.304 \text{ in}}{2} \right)$$

$$= 40,577 \text{ in-lb/lf} = 3,381 \text{ ft-lb/lf}$$

$$\phi P_n = 0$$

$$M_u = 2,434 \text{ ft-lb/lf from step (1)}$$

$$\delta M_u = 1.04 (2,434 \text{ ft-lb/lf}) = 2,531 \text{ ft-lb/lf}$$

By inspection of the interaction diagram, one No. 5 at 24 inches on center is OK because $\delta M_u P_u$ is contained within the interaction curve.

6. Check deflection.

$$\Delta_{\max} = \left[-\frac{q(x-L+1)^5}{120} + \frac{ql^3 x^3}{36L} + \frac{ql^5 x}{120L} - \frac{ql^3 Lx}{36} \right] / E_c I_g$$

$$= \frac{(1728 \text{ in}^3)}{\text{ft}^3} \left[\begin{array}{l} -\frac{(60 \text{ pcf})(6.13 \text{ ft} - 10 \text{ ft} + 8 \text{ ft})^5}{120} + \frac{(60 \text{ pcf})(8 \text{ ft})^3 (6.13 \text{ ft})^3}{36(10 \text{ ft})} \\ + \frac{(60 \text{ pcf})(8 \text{ ft})^5 (6.13 \text{ ft})}{120(10 \text{ ft})} - \frac{(60 \text{ pcf})(8 \text{ ft})^3 (10 \text{ ft})(6.13 \text{ ft})}{36} \end{array} \right] / (3,122,019 \text{ psi}) \left(\frac{(12 \text{ in})(8 \text{ in})^3}{12} \right)$$

$$= 0.025 \text{ in/lf}$$

$$\Delta_{\text{all}} = \frac{L}{240} = \frac{(10 \text{ ft})(12 \text{ in / ft})}{240} = 0.5 \text{ in / lf}$$

$$\Delta_{\max} \ll \Delta_{\text{all}} \text{ OK}$$

Conclusion An 8-inch-thick reinforced concrete wall with one vertical No. 5 bar at 24 inches on center is adequate for the given loading conditions.

This analysis was performed for a given wall thickness and reinforcement spacing. The same equations can be used to solve for the minimum reinforcement that satisfies the requirements for shear, combined bending and axial stress, and deflection. This approach would be suitable for a computer spreadsheet design aid. A packaged computer software program can also be purchased to perform this function; however, certain limitations may prohibit the designer from using design recommendations given in this guide.

The use of horizontal reinforcement varies widely as an optional enhancement. If horizontal reinforcement is used as a matter of preferred practice to control potential cracking, one No. 4 bar placed at the top of the wall and at mid-height typically is sufficient.

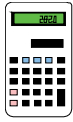

Given

$f_c = 3,000$ psi
 $f_y = 60,000$ psi
 Dead load = 250 plf
 Live load = 735 plf
 Span = 6.5 ft
 Lintel width = 8 in
 Lintel depth = 12 in

Find Minimum reinforcement required

Solution

- Determine reinforcement required for flexure.

$$\phi M_n \geq M_u$$

$$M_u = \frac{wl^2}{12} = \frac{1.2(250 \text{ plf}) + 1.6(735 \text{ plf})}{12} (6.5 \text{ ft})^2 = M_u$$

$$M_u = 5,197 \text{ ft-lb} = 62,361 \text{ in-lb}$$

$$\phi M_n = \phi A_s f_y (d - 0.5a)$$

$$d = 12\text{-in depth} - 1.5\text{-in cover} - 0.375\text{-in stirrup} = 10.125 \text{ in}$$

$$a = \frac{A_s f_y}{0.85 f'_c b}$$

$$\text{set } M_u = \phi M_n \text{ to solve for } A_s$$

$$M_u = \phi A_s f_y \left(d - \frac{1}{2} \left(\frac{A_s f_y}{0.85 f'_c b} \right) \right)$$

$$62,364 \text{ in-lb} = (0.9) A_s (60,000 \text{ psi}) \left(10.125 \text{ in} - 0.5 \left(\frac{A_s (60,000 \text{ psi})}{0.85 (3,000 \text{ psi})(12 \text{ in})} \right) \right)$$

$$0 = 546,750 A_s - 52,941 A_s^2 - 62,364$$

$$A_{s,\text{required}} = 0.115 \text{ in}^2$$

\therefore Use one No. 4 bar ($A_s = 0.20 \text{ in}^2$)

Check reinforcement ratio.

$$\rho = \frac{A_s}{bd} = \frac{0.2 \text{ in}^2}{(10.125 \text{ in})(8 \text{ in})} = 0.0025$$

$$\rho_b = \frac{0.85 f'_c \beta_1}{f_y} \left(\frac{87,000}{f_y + 87,000} \right) = \frac{0.85 (3,000 \text{ psi})(0.85)}{60,000 \text{ psi}} \left(\frac{87,000}{60,000 \text{ psi} + 87,000} \right) = 0.021$$

$$\rho_{\max} = 0.75\rho_b = 0.75(0.021) = 0.016$$

$$\rho_{\min} = 0.0012$$

Because OK

2. Determine shear reinforcement.

$$\phi V_n \geq V_u$$

$$V_u = \frac{wl}{2} = \frac{1.2(250 \text{ plf}) + 1.6(735 \text{ plf})}{2} = (6.5 \text{ ft}) = 4,797 \text{ lb}$$

$$= \text{Span-to-depth ratio, } = = 6.5 > 5 \therefore \text{Regular beam}$$

$$\phi V_n = \phi V_c + 0 = \phi 2\sqrt{f'_c} b_w d = (0.85)(2)\sqrt{3,000 \text{ psi}}(8 \text{ in})(10.125 \text{ in}) = 7,542 \text{ lb}$$

$$V_u \leq \frac{\phi V_c}{2} = \frac{7,542 \text{ lb}}{2} = 3,771 \text{ lb} < 4,797 \text{ lb}$$

\therefore Stirrups are required

Because $\phi V_c > V_u > \frac{\phi V_c}{2}$ only the minimum shear reinforcement must be provided.

$$A_{v,\min} = \frac{50 b_w s}{f_y} = \frac{(50)(8 \text{ in}) \left(\frac{10.125 \text{ in}}{2}\right)}{60,000 \text{ psi}} = 0.034 \text{ in}^2$$

\therefore Use No. 3 bars

Shear reinforcement is not needed when $\frac{\phi V_c}{2} > V_u$

$$3,771 \text{ lb} = 4,797 \text{ lb} - [1.2(250 \text{ plf}) + 1.6(735 \text{ plf})]x$$

$$x = 0.70 \text{ ft}$$

Supply No. 3 shear reinforcement spaced 5 in on center for a distance 0.7 ft from the supports.

3. Check deflection.

Find x for transformed area

$$h x \left(\frac{x}{2}\right) = nA_s (d - x)$$

$$0.5(8 \text{ in})(x)^2 = \left(\frac{29,000,000 \text{ psi}}{3,122,019 \text{ psi}}\right)(0.2 \text{ in}^2)(10.125 \text{ in} - x)$$

$$0 = 4x^2 + 1.86x - 18.8$$

$$x = 1.95 \text{ in}$$

Calculate moment of inertia for cracked section and gross section.

$$\begin{aligned}
 I_{CR} &= \frac{1}{3}hx^3 + nA_s(d-x)^2 \\
 &= \frac{1}{3}(8 \text{ in})(1.95 \text{ in})^3 + (9.29)(0.2 \text{ in}^2)(10.125 \text{ in} - 1.95 \text{ in})^2 = 144 \text{ in}^4 \\
 I_g &= \frac{1}{12}bh^3 = \frac{1}{12}(8 \text{ in})(12 \text{ in})^3 = 1,152 \text{ in}^4
 \end{aligned}$$

Calculate modulus of rupture

$$f_r = 7.5\sqrt{f'_c} = 7.5\sqrt{3,000 \text{ psi}} = 411 \text{ psi}$$

Calculate cracking moment

$$\begin{aligned}
 M_{cr} &= \frac{f_r I_g}{Y_t} = \frac{(411 \text{ psi})(1,152 \text{ in}^4)}{(0.5)(12 \text{ in})} = 78,912 \text{ in-lb/lf} = 6.6 \text{ kip-ft/lf} \\
 &= 10.9 \text{ kNm/m}
 \end{aligned}$$

Calculate effective moment of inertia.

Because the cracking moment M_{cr} is larger than the actual moment M_u , the section is not cracked; thus, $I_e = I_g$.

Calculate deflection

$$\Delta_{\text{allow}} = \frac{l}{240} = \frac{(6.5 \text{ ft})(12 \text{ in/ft})}{240} = 0.33 \text{ in}$$

$$\Delta_{\text{actual}} = \frac{5wl^4}{384E_cI_e}$$

$$\Delta_{i(\text{LL})} = \frac{5(735 \text{ plf})(6.5 \text{ ft})^4}{384(3,122,019 \text{ psi})(1,152 \text{ in}^4)(\text{ft}^3/1,728 \text{ in}^3)} = 0.008 \text{ in}$$

$$\Delta_{i(\text{DL}+20\%\text{LL})} = \frac{5(250 \text{ plf} + (0.20)735 \text{ plf} + (150 \text{ pcf})(0.66 \text{ ft})(1 \text{ ft}))(6.5 \text{ ft})^4}{384(3,122,019 \text{ psi})(1,152 \text{ in}^4)(\text{ft}^3/1,728 \text{ in}^3)} = 0.006 \text{ in}$$

$$\Delta_{LT} = \Delta_{i(\text{LL})} + \lambda\Delta_{i(\text{DL}+20\%\text{LL})}$$

$$= 0.008 \text{ in} + 2(0.0055 \text{ in}) = 0.02 \text{ in}$$

$$\Delta_{LT} \ll \Delta_{\text{allow}} \text{ OK}$$

Conclusion The minimum reinforcement bar required for an 8-inch x 12-inch concrete lintel spanning 6.5 feet is one No. 4 bar.

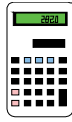

- Given**
- Live load = 1,300 plf
 - Dead load = 900 plf
 - Weight of wall = 52.5 psf
 - Moment at top = 0
 - Masonry weight = 120 pcf
 - Backfill material = 30 pcf
 - $f_m = 1,900$ psi
 - Face shell mortar bedding

Assume axial load is in middle one-third of wall.

- Find** Verify if a 10-in-thick unreinforced masonry wall is adequate for the ACI 530 load combination and 4 ft of unbalanced fill

$$U = D+H$$

Solution

1. Determine loads.

Equivalent fluid density of backfill soil (chapter 3)

$$q_s = K_a w = (0.30)(100 \text{ pcf}) = 30 \text{ pcf}$$

Total lateral earth load

$$R = \frac{1}{2} q_s l^2 = \frac{1}{2} (30 \text{ pcf})(4 \text{ ft})^2 = 240 \text{ plf}$$

$$x = \frac{1}{3} \ell = \frac{1}{3} (4 \text{ ft}) = 1.33 \text{ ft}$$

Maximum shear occurs at bottom of wall

$$\begin{aligned} \Sigma M_{\text{top}} &= 0 \\ V_{\text{bottom}} &= \frac{q l^2}{2} - \frac{q l^3}{6L} = \frac{30 \text{ pcf} (4 \text{ ft})^2}{2} - \frac{30 \text{ pcf} (4 \text{ ft})^3}{6 (8 \text{ ft})} = 200 \text{ plf} \end{aligned}$$

Maximum moment and its location

$$x_m = \frac{ql - \sqrt{q^2 l^2 - 2qV_{\text{bottom}}}}{q}$$

$$x_m = \frac{30 \text{ pcf} (4 \text{ ft}) - \sqrt{(30 \text{ pcf})^2 (4 \text{ ft})^2 - 2(30 \text{ pcf})(200 \text{ plf})}}{(30 \text{ pcf})}$$

$$= 2.37 \text{ ft from base of wall}$$

$$M_{\text{max}} = \frac{qx_m}{2} + \frac{qx_m^3}{6} + V_{\text{bottom}} (x_m)$$

$$= -\frac{30 \text{ pcf} (4 \text{ ft})(2.37 \text{ ft})^2}{2} + \frac{(30 \text{ pcf})(2.37 \text{ ft})^3}{6} + 200 \text{ plf} (2.37 \text{ ft})$$

$$= 204 \text{ ft-lb/lf}$$

2. Check perpendicular shear.

$$\frac{M}{Vd} = \frac{204 \text{ ft-lb/lf} (12 \text{ in/ft})}{200 \text{ plf} (9.625 \text{ in})} = 1.27 > 1$$

$$F_v = \begin{cases} 1.5\sqrt{f'_m} = 1.5\sqrt{1,900 \text{ psi}} = 65.4 \text{ psi} \\ 120 \text{ psi} \\ 37 \text{ psi} + 0.45 \frac{N_v}{A_n} = 37 \text{ psi} + 0.45 \frac{(900 \text{ plf} + 52.5 \text{ psf}(8 \text{ ft} - 2.37 \text{ ft}))}{33 \text{ in}^2} = 53.3 \text{ psi} \end{cases}$$

$$F_v = 53.3 \text{ psi}$$

$$f_v = \frac{3}{2} \left(\frac{V}{A_n} \right) = 1.5 \left(\frac{200 \text{ plf}}{(2 \text{ face shells})(1.375 \text{ in})(12 \text{ in})} \right) = 9.1 \text{ psi}$$

The shear is assumed to be resisted by two face shells because the wall is unreinforced and uncracked.

$$f_v < F_v \text{ OK}$$

3. Check axial compression.

$$A_n = \ell(2b) = (12 \text{ in})(2)(1.25 \text{ in}) = 30 \text{ in}^2$$

$$I = \frac{1}{12} bh^3 + Ad^2$$

$$= 2 \left[\frac{1}{12} (12 \text{ in})(1.25 \text{ in})^3 + (12 \text{ in})(1.25 \text{ in}) \left(\frac{9.625 \text{ in}}{2} - \frac{1.25 \text{ in}}{2} \right)^2 \right]$$

$$= 529 \text{ in}^4$$

$$r = \sqrt{\frac{I}{A_n}} = 4.00 \text{ in}$$

$$S = \frac{I}{c} = 529 \text{ in}^4 / \frac{1}{2}(9.625 \text{ in}) = 110 \text{ in}^3$$

$$\frac{h}{r} = \frac{8 \text{ ft} (12 \frac{\text{in}}{\text{ft}})}{4.00 \text{ in}} = 24 < 99$$

$$F_a = (0.25 f_m) = (0.25)(1,900 \text{ psi}) = 461 \text{ psi} = 1 - \frac{8 \text{ ft} (12 \text{ in} / \text{ft})^2}{140 (4.00 \text{ in})}$$

$$P_{\max} = F_a A_n = (461 \text{ psi})(33 \text{ in}^2) = 15,214 \text{ plf}$$

$$P = 900 \text{ plf (given for } U=D+H)$$

$$900 \text{ plf} < 15,214 \text{ plf OK}$$

Check Euler buckling load.

$$E_m = 900 f_m = 900 (1,900 \text{ psi}) = 1.71 \times 10^6 \text{ psi}$$

$$e_k = \frac{S}{A_n} = \frac{118 \text{ in}^3}{33 \text{ in}^2} = 3.57 \text{ in (kern eccentricity)}$$

$$P_e = \frac{\pi^2 E_m I}{h^2} \left(1 - 0.577 \frac{e}{r}\right)^3$$

$$= \frac{\pi^2 (1.71 \times 10^6 \text{ psi})(567 \text{ in}^4)}{(8 \text{ ft})^2 (12 \text{ in} / \text{ft})^2} \left(1 - 0.577 \left(\frac{3.57 \text{ in}}{4.14 \text{ in}}\right)\right)^3$$

$$= 131,703 \text{ plf}$$

$$P \leq P_e = 0.25 P_e \text{ OK}$$

Euler buckling loads are calculated by using actual eccentricities from gravity loads without including effects of lateral loads.

4. Check combined axial compression and flexural capacity.

$$M = 204 \text{ ft-lb/lf}$$

$$P = 900 \text{ plf}$$

$$\text{virtual eccentricity } e = \frac{204 \text{ ft-lb/lf} (12 \text{ in} / \text{ft})}{900 \text{ plf}} = 2.72 \text{ in}$$

$$\text{kern eccentricity } e_k = \frac{S}{A_n} = \frac{118 \text{ in}^3}{33 \text{ in}^2} = 3.57 \text{ in} \leftarrow \text{GOVERNS}$$

$e < e_k \therefore$ Assume section is uncracked

$$P_e = \frac{\pi^2 E_m I}{h^2} \left(1 - 0.577 \frac{e}{r}\right)^3 = \frac{\pi^2 E_m I}{h^2} \left(1 - 0.577 \frac{e}{r}\right)^3$$

$$= \frac{\pi^2 (900 \text{ plf})(1,900 \text{ psi})(567 \text{ in}^4)}{(8 \text{ ft}(12 \text{ in / ft}))^2} \left(1 - 0.577 \left(\frac{3.57}{4.14}\right)\right)^3$$

$$P_e = 131,703 \text{ plf}$$

$$P < 0.25 (131,703 \text{ plf}) = 32,926 \text{ plf OK}$$

$$f_a = \frac{P}{A_n} = \frac{900 \text{ plf}}{33 \text{ in}^2} = 27 \text{ psi}$$

$$f_b = \frac{M}{S} = \frac{(900 \text{ plf})(3.57 \text{ in})\left(\frac{2.37 \text{ ft}}{8 \text{ ft}}\right) + (204 \text{ ft-lb / lf})(12 \text{ in / ft})}{118 \text{ in}^3}$$

$$= 29 \text{ psi}$$

$$F_a = 462 \text{ psi for } h/r \leq 99$$

$$F_b = 0.33 f_m = 0.33 (1,900 \text{ psi}) = 627 \text{ psi}$$

$$\frac{27 \text{ psi}}{462 \text{ psi}} + \frac{29 \text{ psi}}{627 \text{ psi}} = 0.10 \leq 1 \text{ OK}$$

5. Check tension capacity from table 2.2.3.2 for normal to bed joints, hollow, ungrouted (type M or S mortar).

$$F_t \leq 25 \text{ psi}$$

$$f_t = -\frac{P}{A_n} + \frac{M}{S} = -\frac{900 \text{ plf}}{33 \text{ in}^2} + \frac{3,400 \text{ ft-lb / lf}}{118 \text{ in}^3} = 1.54 \text{ psi}$$

$$f_t < F_t \text{ OK}$$

6. Minimum reinforcement.

Horizontal reinforcement at 24 inches on center vertically

Conclusion An unreinforced masonry wall is adequate for the ACI 530 load combination evaluated; however, horizontal reinforcement at 16 inches on center may be provided optionally to control potential shrinkage cracking, particularly in long walls (i.e., greater than 20 to 30 feet long).

If openings are present, use lintels and reinforcement as suggested in sections 4.5.2.3 and 4.5.2.4.

Note that the calculations have already been completed and that the maximum backfill height calculated for an 8-inch-thick unreinforced masonry wall using hollow concrete masonry is about 5 feet, with a safety factor of 4.

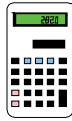

Given

Live load = 1,300 plf
 Dead load = 900 plf
 Moment at top = 0
 Masonry weight = 120 pcf
 Wall weight = 52.5 psf
 Backfill material = 45 pcf
 $f'_m = 2,000$ psi
 Face shell mortar bedding
 Type M or S mortar
 Wall is partially grouted, one core is grouted at 24 inches on center
 Assume axial load is in middle one-third of wall

Find Verify if one vertical No. 5 bar at 24 inches on center is adequate for a reinforced concrete masonry foundation wall that is 8 feet high with 7 feet of unbalanced backfill for the ACI 530 load combination.

$$U = D + H$$

Solution

1. Determine loads.

Equivalent fluid density of backfill soil (refer to chapter 3)

$$q = K_a W = (0.45)(100) = 45 \text{ pcf}$$

Total lateral earth load

$$R = \frac{1}{2} q l^2 = \frac{1}{2} (45 \text{ pcf})(7 \text{ ft})^2 = 1,103 \text{ lb}$$

$$X = \frac{1}{3} \ell = \frac{1}{3} (7 \text{ ft}) = 2.33 \text{ ft}$$

Maximum shear occurs at bottom of wall.

$$\begin{aligned} \sum M_{\text{top}} &= 0 \\ V_{\text{bottom}} &= \frac{q l^2}{2} - \frac{q l^3}{6L} = \frac{45 \text{ pcf} (7 \text{ ft})^2}{2} - \frac{(45 \text{ pcf}) (7 \text{ ft})^3}{6 (8 \text{ ft})} \\ &= 781 \text{ plf} \end{aligned}$$

Maximum moment and its location

$$\begin{aligned} x_m &= \frac{q l - \sqrt{q^2 l^2 - 2q V_{\text{bottom}}}}{q} \\ &= \frac{(45 \text{ pcf})(7 \text{ ft}) - \sqrt{(45 \text{ pcf})^2 (7 \text{ ft})^2 - 2(45 \text{ pcf})(781 \text{ plf})}}{45 \text{ pcf}} \\ &= 3.2 \text{ ft from base of wall} \end{aligned}$$

$$\begin{aligned}
M_{\max} &= \frac{q_1 x_m^2}{2} + \frac{q_2 x_m^3}{6} + V_{\text{bottom}}(x_m) \\
&= \frac{-45 \text{ pcf}(7 \text{ ft})(3.2 \text{ ft})^2}{2} + \frac{(45 \text{ pcf})(3.2 \text{ ft})^3}{6} + (781 \text{ plf})(3.2 \text{ ft}) \\
&= 1,132 \text{ ft-lb/lf}
\end{aligned}$$

2. Check perpendicular shear.

$$\frac{M}{Vd} = \frac{1,132 \text{ ft-lb/lf}(12 \text{ in/ft})}{(781 \text{ plf})(9.625 \text{ in})} = 1.8 > 1$$

$$\begin{aligned}
F_v &= 1\sqrt{f'_m} \leq 50 \text{ psi} \\
&= 1\sqrt{2,000 \text{ psi}} = 44.7 \text{ psi} < 50 \text{ psi}
\end{aligned}$$

$$F_v = (44.7 \text{ psi})(2\text{-ft grouted core spacing}) = 89 \text{ psi}$$

$$\begin{aligned}
A_e &= A_{\text{CMU faceshells}} + A_{\text{core}} \\
&= (24 \text{ in} - 8.375 \text{ in})(2)(1.375 \text{ in}) + (1.125 \text{ in} + 1.375 \text{ in} + 5.875 \text{ in})(9.625 \text{ in}) \\
&= 124 \text{ in}^2
\end{aligned}$$

$$f_v = \frac{V}{bd} = \frac{V}{A_e} = \frac{(781 \text{ plf})(2 \text{ ft rebar spacing})}{(124 \text{ in}^2)} = 13 \text{ psi}$$

$$f_v < F_v \text{ OK}$$

This assumes that both mortared face shells are in compression.

3. Check parallel shear.

Foundation walls are constrained against lateral loads by the passive pressure of the soil and soil-wall friction. Parallel shear on the foundation wall can be neglected by design inspection.

4. Check axial compression.

$$\begin{aligned}
A_e &= 124 \text{ in}^2 \\
I &= \frac{1}{12}bh^3 + Ad^2 \\
&= \frac{1}{12} = (8.375 \text{ in})(9.625 \text{ in} - 2(1.375 \text{ in})) \\
&\quad + 2 \left[\left(\frac{1}{12} \right) (24 \text{ in})(1.375 \text{ in})^3 + (24 \text{ in})(1.375 \text{ in}) \left(\frac{9.625 \text{ in}}{2} - \frac{1.375 \text{ in}}{2} \right)^2 \right] \\
&= 1,138 \text{ in}^4 \\
r &= \sqrt{\frac{I}{A_e}} = 3.03 \text{ in}
\end{aligned}$$

$$\frac{h}{r} = \frac{8 \text{ ft} (12 \text{ in} / \text{ft})}{3.03 \text{ in}} = 32 < 99$$

$$\begin{aligned} \therefore F_a &= (0.25 f_m) \left(1 - \left(\frac{h}{140r} \right)^2 \right) \\ &= 0.25 (2,000 \text{ psi}) \left(1 - \left(\frac{(8 \text{ ft})(12 \text{ in} / \text{ft})}{140(3.03 \text{ in})} \right)^2 \right) = 474 \text{ psi} \end{aligned}$$

$$P_{\max} = F_a A_e = (474 \text{ psi})(124 \text{ in}^2) = 58,776 \text{ lb}$$

$$P = 900 \text{ lb}$$

$$P < P_{\max} \quad \text{OK}$$

5. Check combined axial compression and flexural capacity.

$$M = 1,132 \text{ ft-lb/lf}$$

$$P = 900 \text{ plf}$$

$$\text{virtual eccentricity} = e = \frac{M/P}{P/P}$$

$$= \frac{1,132 \text{ ft-lb/lf}(12 \text{ in} / \text{ft})}{900 \text{ plf}} = 15 \text{ in} \quad \leftarrow \text{Governs}$$

$$\text{kern eccentricity} = e_k = \frac{S}{A_e} \frac{S}{A_e}$$

$$= \frac{1,138 \text{ in}^4 / 0.5(9.625 \text{ in})}{124 \text{ in}^2} = 1.9 \text{ in}$$

$e > e_k \quad \therefore$ Tension on section, assume cracked

$$f_a = \frac{P}{A_e} = \frac{900 \text{ plf}(2 \text{ ft})}{124 \text{ in}^2} = 14.5 \text{ psi}$$

$$f_b = \frac{M}{S} = \frac{1,132 \text{ ft-lb/lf}(12 \text{ in} / \text{ft})}{236.5 \text{ in}^3} = 57 \text{ psi}$$

$$f_b > f_a$$

\therefore Assume section is cracked

$$F_a = 0.25 f_m \left[1 - \left(\frac{h}{140r} \right)^2 \right] \left[1 - \left(\frac{h}{140r} \right)^2 \right]$$

$$= 0.25 (2,000 \text{ psi}) \left[1 - \left(\frac{8 \text{ ft}(12 \text{ in / ft})}{140(3.03 \text{ in})} \right)^2 \right]$$

$$= 474 \text{ psi}$$

$$F_b = 0.33 f_m = 0.33 (2,000 \text{ psi}) = 660 \text{ psi}$$

$$\frac{f_a}{F_a} + \frac{f_b}{F_b} \leq 1$$

$$\frac{14.5 \text{ psi}}{474 \text{ psi}} + 0.12 \leq 1 \text{ OK}$$

6. Check tension.

$$\begin{aligned} M_t &= A_s d F_s \\ &= (0.155 \text{ in}^2)(0.5)(9.625 \text{ in})(24,000 \text{ psi}) \\ &= 17,903 \text{ in-lb/lf} \\ M &= (1,132 \text{ ft-lb/lf})(12 \text{ in/ft}) \\ &= 13,584 \text{ in-lb/lf} \end{aligned}$$

$$M < M_t \text{ OK}$$

Conclusion One vertical No. 5 bar at 24 inches on center is adequate for the given loading combination. In addition, horizontal truss-type reinforcement is recommended at 24 inches (that is, every third course of block).

Load combination D+H controls design; therefore, a check of D+L+H is not shown.

Table 4.5 would allow a 10-inch-thick solid unit masonry wall without rebar in soil with 30 pcf equivalent fluid density. This practice has succeeded in residential construction except as reported in places with “heavy” clay soils; therefore, a design as shown in this example may be replaced by a design in accordance with the applicable residential codes’ prescriptive requirements. The reasons for the apparent inconsistency may be attributed to a conservative soil pressure assumption or a conservative safety factor in ACI 530 relative to typical residential conditions.

4.10 References

- American Concrete Institute (ACI). 2010. *Guide to Design of Slabs on Ground*. ACI Standard 360-10. Farmington Hills, MI: ACI.
- . 2011. *Building Code Requirements for Masonry Structures*. ACI Standard 530. Farmington Hills, MI: ACI.
- . 2011. *Building Code Requirements for Structural Concrete and Commentary*. ACI Standard 318-11. Farmington Hills, MI: ACI.
- . 2010. *Residential Code Requirements for Structural Concrete*. ACI Standard 332-10. Farmington Hills, MI: ACI.
- American Forest and Paper Association (AF&PA). 2007. *Permanent Wood Foundation Design Specification*. Washington, DC: AF&PA and American Wood Council.
- American Society of Civil Engineers (ASCE). 2001. *Design Guide for Frost-Protected Shallow Foundations, ASCE 32-01*. Reston, VA: ASCE.
- American Society for Testing & Materials (ASTM). 2011. *Standard Penetration Test and Split-Barrel Sampling of Soils* ASTM Standard D1586-11. West Conshohocken, PA: ASTM.
- . 2012a. *Standard Specification for Mortar for Unit Masonry*. ASTM Standard C270-12. West Conshohocken, PA: ASTM.
- . 2012b. *Standard Specification for Portland Cement*. ASTM Standard C150-12. West Conshohocken, PA: ASTM.
- . 2012c. *Standard Test Method for Compressive Strength of Cylindrical Concrete Specimens*. ASTM Standard C39-12. West Conshohocken, PA: ASTM.
- . 2012d. *Standard Test Method for Slump of Hydraulic Cement Concrete*. ASTM Standard C143-12. West Conshohocken, PA: ASTM.
- . 2013. *Standard Specification for Loadbearing Concrete Masonry Units*. ASTM Standard C90-13. West Conshohocken, PA: ASTM.
- American Wood Council (AWC). 2012. *National Design Specification for Wood Construction*. Leesburg, VA: AWC.
- American Wood Protection Association. 2013. *AWPA Book of Standards*. Birmingham, AL: AWP.

- Beall, Christine. 2012. *Masonry Design and Detailing for Architects, Engineers, and Contractors*, 6th ed. New York: McGraw-Hill.
- Burnham, T. R. and Johnson, D. 1993. *In Situ Foundation Characterization Using the Dynamic Cone Penetrometer*. Maplewood, MN: Minnesota Department of Transportation.
- Federal Emergency Management Agency (FEMA). 2009. *NEHRP Recommended Seismic Provisions for New Buildings and Other Structures, FEMA P-1050*. Washington, DC: FEMA.
- . 2011a. *Coastal Construction Manual*, FEMA 55, 3rd ed. Washington, DC: FEMA.
- . 2011b. *Home Builder's Guide to Coastal Construction, FEMA P-499*. Washington, DC: FEMA.
- International Code Council (ICC). 2012. *International Residential Code*. Washington, DC: ICC.
- National Association of Home Builders (NAHB) Research Center. 1996. *Frost Protected Shallow Foundations in Residential Construction*, 2nd ed. Upper Marlboro, MD: NAHB.
- National Concrete Masonry Association (NCMA). TEK Notes. Herndon, VA: NCMA.
- Naval Facilities Engineering Command (NAVFAC). 1986. *Foundations and Earth Structures, Design Manual 7.02*. Washington, DC: U.S. Government Printing Office
- Portland Cement Association (PCA). 1998. *Structural Design of Insulating Concrete Form Walls in Residential Construction*. Skokie, IL: Portland Cement Association.
- . 2007. *Prescriptive Design of Exterior Concrete Walls for One- and Two-Family Dwellings*, PCA-100. Skokie, IL: Portland Cement Association.
- Pile Buck, Inc. 1990. *Coastal Construction*. Jupiter, FL: Pile Buck, Inc.
- . 2011. *Pile Driving by Pile Buck*. Jupiter, FL: Pile Buck, Inc.
- Post-Tensioning Institute (PTI). 2008. *Design and Construction of Post-Tensioned Slabs on Ground, DC 10.1-08*. Phoenix, AZ: PTI.

- Roller, John. 1996. *Design Criteria for Insulating Concrete Form Wall Systems*. RP, Vol. 116. Prepared by the Construction Technology Lab for the Portland Cement Association. Skokie, IL: Portland Cement Association.
- The Masonry Society (TMS). 2011. *Building Code Requirements for Masonry Structures*. TMS Standard 402. Longmont, CO: TMS.
- U.S. Department of Housing and Urban Development (HUD). 2002. *Prescriptive Method for Insulating Concrete Forms in Residential Construction*, 2d Ed Prepared for the U.S. Department of Housing and Urban Development and Portland Cement Association by the NAHB Research Center, Inc. Washington, DC: HUD.
- . 1998. *Testing & Design of Lintels Using Insulating Concrete Forms*. Prepared for the U.S. Department of Housing and Urban Development and the Portland Cement Association by the NAHB Research Center, Inc., Upper Marlboro, MD. Skokie, IL: Portland Cement Association.
- Westergaard, Harold M. 1926. *Analysis of Stresses in Concrete Pavements Due to Variations of Temperature*. *Proceedings, Highway Research Board*. Washington, D.C: DOT.



CHAPTER 5

Design of Wood Framing

5.1 General

This chapter addresses elements of above-grade structural systems in residential construction. As discussed in chapter 1, the residential construction material most commonly used above grade in the United States is light-frame wood; therefore, this chapter focuses on structural design that specifies standard dimension lumber and structural wood panels (that is, plywood and oriented strand board [OSB] sheathing). Design of the lateral force resisting system (shear walls and diaphragms) must be approached from a system design perspective and is addressed in chapter 6. Chapter 7 addresses connections; their importance relative to the overall performance of wood-framed construction cannot be overemphasized. Figure 5.1 shows the basic components and assemblies of a conventional wood-frame home; chapter 1 contains more detailed references to house framing and related construction topics.

Many elements of a home work together as a system to resist lateral and axial forces imposed on the above-grade structure and transfer them to the foundation. The above-grade structure also helps resist lateral soil loads on foundation walls through connection of floor systems to foundations. The issue of system performance, therefore, is most critical in the above-grade assemblies of light-frame homes. This chapter addresses system-based design principles within the context of simple engineering approaches that are familiar to designers.

The design of the above-grade structure involves (1) floors, (2) walls, and (3) roofs.

FIGURE 5.1

Components and Assemblies of a Conventional Wood-Framed Home

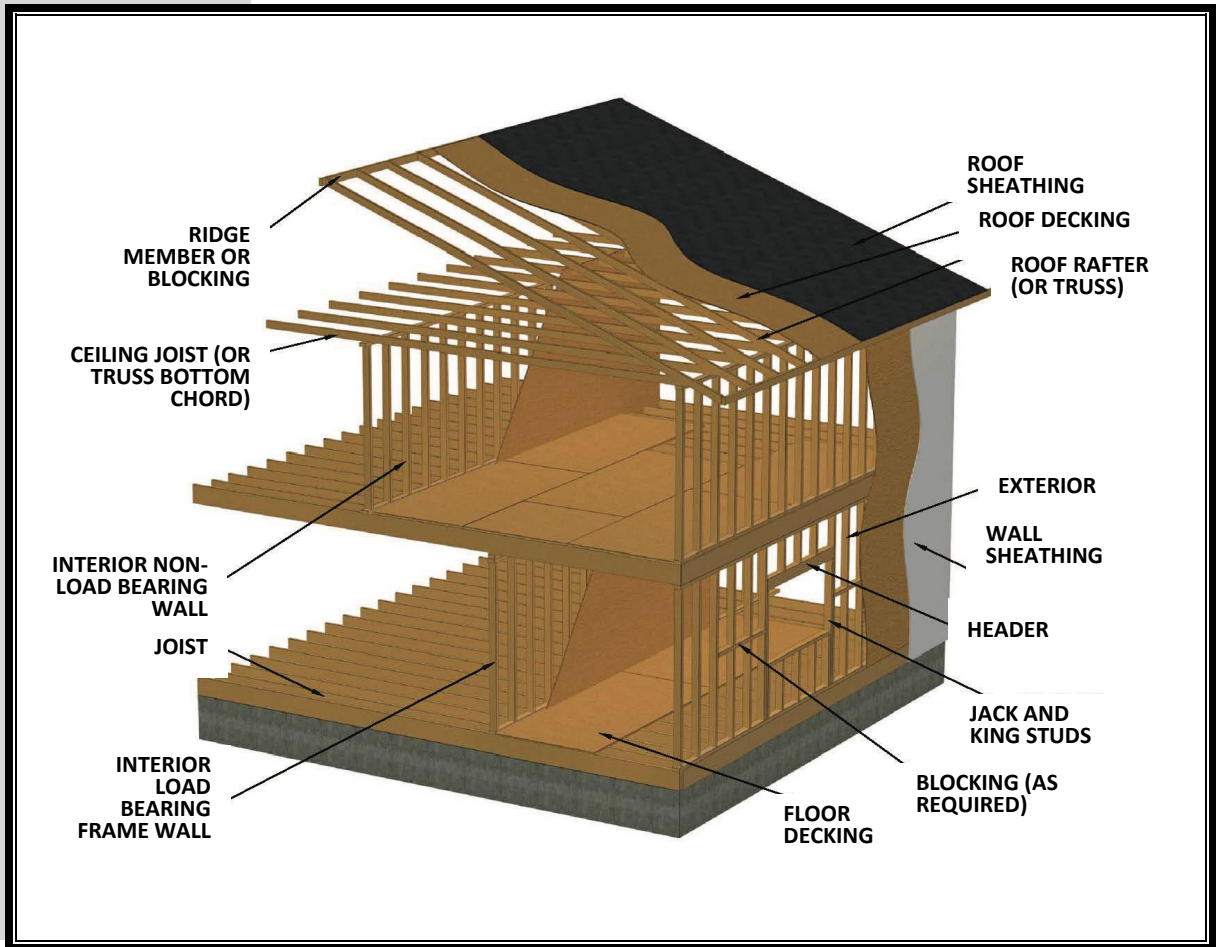

Each system can be complex to design as a whole; therefore, simple analysis usually focuses on the individual elements (subassemblies) that constitute the system. In some cases, “system effects” may be considered in simplified form and applied to the design of certain elements that constitute specifically defined systems. Structural elements that make up a residential structural system include—

- Bending members.
- Columns.
- Combined bending and axial loaded members.
- Sheathing (that is, diaphragm).
- Connections.

The principal method of design for wood-framed construction has historically been allowable stress design (ASD). This chapter uses the most current version of the ASD method (AWC, 2012b), although the load and resistance factor design (LRFD) method is now available as an alternative (AWC, 2012b). The ASD method is detailed in the *National Design Specification for Wood Construction* (NDS) and its supplement (NDS-S). The designer is encouraged to obtain the NDS commentary to develop a better understanding of the rationale and substantiation for the NDS (AWC, 2012a).

This chapter looks at the NDS equations in general and includes design examples that detail the appropriate use of the equations for specific structural elements or systems in light, wood-framed construction. The discussion focuses primarily on framing with traditional dimension lumber but gives some consideration to common engineered wood products. Other wood framing methods, such as post-and-beam construction, are not explicitly addressed in this chapter, although much of the information is relevant. System considerations and system factors presented in this chapter are relevant only to light, wood-framed construction using dimension lumber, however.

Regardless of the type of structural element to analyze, the designer must first determine nominal design loads. The loads acting on a framing member or system usually are calculated in accordance with the applicable provisions of the locally approved building code and engineering standards. The nominal design loads and load combinations used in this chapter follow the recommendations in chapter 3 for residential design.

Although prescriptive design tables (that is, span tables) and similar design aids commonly used in residential applications are not included herein, the designer may save considerable effort by consulting such resources. Most local, state, or national model building codes, such as the *International Residential Code* (IRC; ICC, 2012), contain prescriptive design and construction provisions for conventional residential construction. Similar prescriptive design aids and efficient framing practices can be found in *Cost-Effective Home Building: A Design and Construction Handbook* (NAHBRC, 1994). For high-wind conditions, prescriptive guidelines for design and construction can be found in the *Wood Frame Construction Manual* (AWC, 2012c) and ICC 600, *Standard for Residential Construction in High Wind Regions* (ICC, 2008). The designer is also encouraged to obtain design data on a variety of proprietary engineered wood products that are suitable for many special design needs in residential construction. These materials generally should not be viewed as simple “one-to-one” substitutes for conventional wood framing, however, and any special design and construction requirements should be carefully considered in accordance with the manufacturer’s recommendation or applicable code evaluation reports.

5.2 Material Properties

A designer specifying wood materials for residential construction must understand the natural characteristics of wood and their effect on the engineering

properties of lumber. A brief discussion of the properties of lumber and structural wood panels follows.

5.2.1 Lumber

General

As with all materials, the designer must consider wood's strengths and weaknesses. A comprehensive source of technical information on wood characteristics is the *Wood Handbook: Wood as an Engineering Material, Centennial Edition* (Forest Products Laboratory, 2013). For the most part, the knowledge embodied in the handbook is reflected in the provisions of the NDS and NDS-S design data; however, many aspects of wood design require good judgment.

Wood is a natural material that, as a structural material, demonstrates unique and complex characteristics. Wood's structural properties can be traced back to the material's natural composition. Foremost, wood is a nonhomogeneous, non-isotropic material and thus exhibits different structural properties depending on the orientation of stresses relative to the grain of the wood. The grain is produced by a tree's annual growth rings, which determine the properties of wood along three orientations: tangential, radial, and longitudinal.

Given that lumber is cut from logs in the longitudinal direction, the grain is parallel to the length of a lumber member. Depending on where the lumber is cut relative to the center of a log (that is, tangential versus radial), properties vary across the width and thickness of an individual member.

Wood Species

Structural lumber can be manufactured from a variety of wood species; however, the various species used in a given locality are a function of the economy, regional availability, and required strength properties. A wood species is classified as either hardwood or softwood. *Hardwoods* are broad-leaved deciduous trees, whereas *softwoods* (that is, conifers) are trees with needle-like leaves and are generally evergreen.

Most structural lumber is manufactured from softwoods because of the trees' faster growth rate, availability, and workability (ease of cutting, nailing, and so forth). A wood species is further classified into groups or combinations, as defined in the NDS. Species within a group have similar properties and are subject to the same grading rules. Douglas-Fir-Larch, Southern Yellow Pine, Hem-Fir, and Spruce-Pine-Fir are species groups that are widely used in residential applications in the United States.

Lumber Sizes

Wood members are referred to by nominal sizes (for example, 2x4); however, true dimensions are somewhat smaller. The difference occurs during the dressing stage of the lumber process, when each surface of the member is planed to its final dressed dimension after shrinkage has occurred as a result of the drying, or “seasoning,” process. Generally, there is a 1/4- to 3/4-inch difference between the nominal and dressed sizes of “dry” sawn lumber. For example, a 2x4 is about 1.5 inches by 3.5 inches, a 2x10 is 1.5 inches by 9.25 inches, and a 1x4 is 0.75 inch by 3.5 inches. This guide uses nominal member size, but the designer must use the true dimensions of the lumber when analyzing structural performance or detailing construction dimensions.

Based on the expected application, the tabulated values in the NDS are classified by the species of wood as well as by the nominal size of a member. Typical NDS classifications follow.

- *Boards* are less than 2 inches thick.
- *Dimension lumber* is 2 to 4 inches thick and a minimum of 2 inches wide.
- *Beams and stringers* are a minimum of 5 inches thick, with the width at least 2 inches greater than the thickness.
- *Posts and timbers* are a minimum of 5 inches thick, and the width does not exceed the thickness by more than 2 inches.
- *Decking* is 2 to 4 inches thick and loaded in the weak axis of bending for a roof, floor, or wall surface.

Most wood used in light-frame residential construction takes the form of dimension lumber.

Lumber Grades

Lumber is graded in accordance with standardized grading rules that consider the effect of natural growth characteristics and “defects,” such as knots and angle of grain, on the member’s structural properties. Growth characteristics reduce the overall strength of the member relative to a “perfect,” clear-grained member without any natural defects. Most lumber is visually graded, although it may also be machine stress-rated or machine evaluated.

Visually graded lumber is graded by an individual who examines the wood member at the mill in accordance with an approved agency’s grading rules. The grader separates wood members into the appropriate grade classes. Typical visual grading classes in order of decreasing strength properties are Select Structural, No. 1, No. 2, and Stud. NDS-S contains more information about grades of different species of lumber. The designer should consult a lumber supplier or contractor regarding locally available lumber species and grades.

Machine stress-rated (MSR) lumber and *machine-evaluated lumber* (MEL) is subjected to nondestructive testing of each piece. The wood member is

then marked with the appropriate grade stamp, which includes the allowable bending stress (F_b) and the modulus of elasticity (E). This grading method yields lumber with more consistent structural properties than results from visual grading only.

While grading rules vary among grading agencies, the U.S. Department of Commerce has set forth minimums for voluntary adoption by the recognized lumber grading agencies. For more information regarding grading rules, refer to *American Softwood Lumber Voluntary Product Standard* (USDOC PS-20), which is maintained by the National Institute for Standards and Technology (NIST, 2010a). The NDS-S lists approved grading agencies and roles.

Moisture Content

Wood properties and dimensions change with moisture content (MC). Living wood contains a considerable amount of free and bound water. Free water is contained between the wood cells and is the first water to be driven off in the drying process. Its loss affects neither volume nor structural properties. Bound water is contained within the wood cells and accounts for most of the moisture under 30 percent; its loss results in changes in both volume (that is, shrinkage) and structural properties. The strength of wood peaks at about 10 to 15 percent MC.

Given that wood generally has an MC of more than 30 percent when cut and may dry to an equilibrium moisture content (EMC) of 8 to 10 percent in a protected environment, it should be sufficiently dried or seasoned before installation. Proper drying and storage of lumber minimizes problems associated with lumber shrinkage and warping. A minimum recommendation calls for using “surface dry” lumber with a maximum 19 percent MC. In uses for which shrinkage is critical, specifications may call for “KD-15,” which is kiln-dried lumber with a maximum MC of 15 percent. The tabulated design values in the NDS are based on an MC of 19 percent for dimension lumber.

The designer should plan for the vertical movement that may occur in a structure as a result of shrinkage. For more complicated structural details that call for various types of materials and systems, the designer may have to account for differential shrinkage by isolating members that will shrink from those that will maintain dimensional stability. The designer should also detail the structure such that shrinkage is as uniform as possible, thereby minimizing shrinkage effects on finish surfaces. When practical, details that minimize the amount of wood transferring loads perpendicular to grain are preferable.

Shrink and swell can be estimated in accordance with section 5.3.2 for the width and thickness of wood members (that is, tangentially and radially with respect to annual rings). Shrinkage in the longitudinal direction of a wood member (that is, parallel to grain) is negligible, unless juvenile wood is involved.

Durability

Moisture is a primary factor affecting the durability of lumber. Fungi, which feed on wood cells, require moisture, air, and favorable temperatures to survive. When wood is subject to moisture levels above 20 percent and other favorable conditions, decay begins to set in; therefore, it is important to protect wood materials from moisture by doing the following—

- Limiting end use (for example, by specifying interior applications or isolating lumber from ground contact).
- Using a weather barrier (siding, roofing, building wrap, flashing, and so on).
- Applying a protective coating (such as paint or water repellent).
- Installing roof overhangs and gutters.
- Specifying preservative-treated or naturally decay-resistant wood.

For homes, an exterior weather barrier (for example, roofing and siding) protects most structural wood; however, improper detailing can lead to moisture intrusion and decay. Problems are commonly associated with improper or missing flashing and undue reliance on caulking to prevent moisture intrusion. For additional information and guidance on improving the durability of wood in buildings, the designer may refer to *Durability by Design* (HUD, 2015) and *Moisture Resistant Homes* (HUD, 2006).

Wood members that are in ground contact should be preservative treated. Preservative treatment is accomplished with a variety of chemicals and chemical processes; the process usually is either submersion or pressure injection, and the chemicals likely contain a form of copper or borate. Some of the chemicals harm metals, so metal connectors used to attach wood to buildings or to connect wood members together must be carefully selected. The most common lumber treatment historically had been CCA (copper-chromium-arsenate), but this product is generally unavailable for use in the residential market. Alternative treatments for wood include alkaline copper quaternary (ACQ), borates and copper azole, in addition to other chemical and non-chemical treatments. Designers should understand the performance of the wood preservative approach selected.

Termites and other wood-destroying insects (for example, carpenter ants and boring beetles) attack wood materials. Some practical solutions include chemical treatment of soil, installation of physical barriers (such as termite shields), and the use of treated lumber.

Termites are a special problem in warmer climates, although they also plague many other areas of the United States. The most common termites are “subterranean” termites that nest in the ground and enter wood that is near or in contact with damp soil. They gain access to above-grade wood through cracks in the foundation or through shelter tubes (that is, mud tunnels) on the surface of foundation walls. Because the presence of termites can be visually detected, wood-framed homes require periodic inspection for signs of termites.

Certain wood species are naturally decay resistant, including cedar, redwood, cypress, mahogany, and a few others. Some of these products are easy to obtain (cedar and redwood), some are expensive (mahogany), and some are in short supply (cypress). Even some of those woods are not very decay resistant, however, if the wood member is cut from the softest part of the tree. Many examples of cedar used outside and placed in contact with the ground reveal that decay has occurred in 10 years or less. A designer must exercise care when selecting wood to be used outside or in a wet environment.

5.2.2 Wood Structural Panels

Boards historically were used for roof, floor, and wall sheathing; in the past 50 years, however, structural wood panel products have come to dominate the sheathing market. Structural wood panel products are more economical and efficient and typically are stronger than traditional board sheathing. Structural wood panel products include plywood and oriented strand board (OSB).

Plywood is manufactured from wood veneers glued together under high temperature and pressure. Each veneer or ply is placed with its grain perpendicular to the grain of the previous layer. The outer layers are placed with their grain parallel to the longer dimension of the panel. Thus, plywood is stronger in bending along the long direction and should be placed with the long dimension spanning floor and roof framing members. The number of plies typically ranges from 3 to 5. OSB is manufactured from thin wood strands glued together under high temperature and pressure. The strands are layered and oriented to produce properties that are consistent in all directions.

The designer should specify the grade and span rating of structural wood panels to meet the required application and loading condition (that is, roof, wall, or floor). The most common panel size is 4 feet wide by 8 feet long, with thicknesses typically ranging from 1/4 inch to more than 1 inch. Panels can be ordered in longer lengths for special applications, especially for tall walls and for overlapping sheathing onto floor framing to improve vertical uplift load path continuity.

Plywood is performance rated according to the provisions of USDOC PS 1-09 for industrial and construction plywood (NIST, 2009). OSB products are performance rated according to the provisions of USDOC PS 2-10 (NIST, 2010b). Those standards are voluntary, however, and not all wood-based panel products are rated accordingly. APA—The Engineered Wood Association’s (formerly American Plywood Association’s) rating system for structural wood panel sheathing products and those used by other structural panel trademarking organizations are based on the U.S. Department of Commerce voluntary product standards.

The veneer grade of plywood is associated with the veneers used on the exposed faces of a panel as follows.

Grade A: The highest quality veneer grade, which is intended for cabinet or furniture use.

- Grade B: A high-quality veneer grade, which is intended for cabinet or furniture use with all defects repaired.
- Grade C: The minimum veneer grade, which is intended for exterior use.
- Grade D: The lowest quality veneer grade, which is intended for interior use or where protected from exposure to weather.

The wood strands or veneer layers used in wood structural panels are bonded with adhesives, and they vary in moisture resistance; therefore, wood structural panels are also classified with respect to end-use exposure, as follows.

- *Exterior* panels are designed for applications with permanent exposure to the weather or moisture.
- *Exposure 1* panels are designed for applications in which temporary exposure to the weather due to construction sequence may be expected.

Typical span ratings for structural wood panels specify either the maximum allowable center-to-center spacing of supports (for example, 24 inches on center for roof, floor, or wall) or two numbers separated by a slash to designate the allowable center-to-center spacing of roof and floor supports, respectively (for example, 48/24). Even though the second rating method does not specifically indicate wall stud spacing, the panels may also be used for wall sheathing. The *Engineered Wood Construction Guide* provides a correlation between roof/floor ratings and allowable wall support spacing (APA, 2011a). The *Load-Span Tables for APA Structural-Use Panels* (APA, 2011b) provide span ratings for various standard and nonstandard loading conditions and deflection limits.

5.2.3 Lumber Design Values

The NDS-S provides tabulated design stress values for bending, tension parallel to grain, shear parallel to grain, compression parallel and perpendicular to grain, and modulus of elasticity. The 2012 edition of the NDS (AWC, 2012b) includes the design values based on test results conducted prior to 2012. In 2012, however, the allowable stress values for southern pine lumber were revised again based on very recent testing. Those new values are not reflected in the 2012 NDS, although addenda are available with this information and should be used for design.

Characteristic structural properties for use in ASD (ASTM D1990) and LRFD (ASTM D5457) are used to establish design values (ASTM, 2007; ASTM, 2012). Test data collected in accordance with the applicable standards determine a characteristic strength value for each grade and species of lumber. The value usually is the mean (average) or fifth percentile test value. The fifth percentile represents the value that 95 percent of the sampled members exceeded. Reduction factors are applied to the allowable values published in the NDS-S for standardized conditions. The reduction factor normalizes the lumber properties to a standard set of conditions related to load duration, MC, and other factors. It also

includes a safety adjustment if applicable to the particular limit state (that is, ultimate capacity). For specific design conditions that differ from the standard basis, therefore, design property values should be adjusted as described in section 5.2.4.

5.2.4 Adjustment Factors

The allowable values published in the NDS-S are determined for a standard set of conditions, yet, many variations in the characteristics of wood affect the material's structural properties. For efficient design, designers must make appropriate adjustments for conditions that vary from those used to derive the standard design values. Table 5.1 presents adjustment factors that apply to different structural properties of wood. The following sections briefly discuss the adjustment factors most commonly used in residential applications. For information on other adjustment factors, refer to the NDS, NDS-S, and NDS commentary.

TABLE 5.1 *Adjustment Factor Applicability to Design Values for Wood*

Design Properties ¹	Adjustment Factor ²														
	C_D	C_r	C_H	C_F	C_P	C_L	C_M	C_{fu}	C_b	C_T	C_V	C_t	C_i	C_c	C_f
F_b	X	X		X		X	X	X			X	X	X	X	X
F_t	X			X			X					X	X		
F_v	X		X				X					X	X		
$F_{c\perp}$							X		X			X	X		
F_c	X			X	X		X					X	X		
E							X			X		X	X		

¹Basic or unadjusted values for design properties of wood are found in NDS-S.

²Shaded cells represent factors most commonly used in residential applications; other factors may apply to special conditions.

Source: Based on NDS•2.3 (AWC, 2012b)

Key to Adjustment Factors:

- **C_D , Load Duration Factor.** Applies when loads are other than “normal” 10-year duration (see section 5.2.4.1 and NDS•2.3.2).
- **C_r , Repetitive Member Factor.** Applies to bending members in assemblies with multiple members spaced at maximum 24 inches on center (see section 5.2.4.2 and NDS•4.3.4).
- **C_H , Horizontal Shear Factor.** Applies to individual or multiple members with regard to horizontal, parallel-to-grain splitting (see section 5.2.4.3 and NDS-S).
- **C_F , Size Factor.** Applies to member sizes or grades other than “standard” test specimens, but does not apply to Southern Yellow Pine (see section 5.2.4.4 and NDS-S).
- **C_P , Column Stability Factor.** Applies to lateral support condition of compression members (see section 5.2.4.5 and NDS•3.7.1).

- **C_L , Beam Stability Factor.** Applies to bending members not subject to continuous lateral support on the compression edge (see section 5.2.4.6 and NDS•3.3.3).
- **C_M , Wet Service Factor.** Applies where the MC is expected to exceed 19 percent for extended periods (see NDS-S).
- **C_{fu} , Flat Use Factor.** Applies where dimension lumber 2 to 4 inches thick is subject to a bending load in its weak axis direction (see NDS-S).
- **C_b , Bearing Area Factor.** Applies to members with bearing between 3 and 6 inches from the members' ends (see NDS•2.3.10).
- **C_T , Buckling Stiffness Factor.** Applies only to maximum 2x4 dimension lumber in the top chord of wood trusses that are subjected to combined flexure and axial compression (see NDS•4.4.3).
- **C_V , Volume Factor.** Applies to glulam bending members loaded perpendicular to the wide face of the laminations in strong axis bending (see NDS•5.3.2).
- **C_t , Temperature Factor.** Applies where temperatures exceed 100°F for long periods; not normally required when wood members are subjected to intermittent higher temperatures, such as in roof structures (see NDS•2.4.3 and NDS•appendix C).
- **C_i , Incising Factor.** Applies where structural sawn lumber is incised to increase penetration of preservatives, with small incisions cut parallel to the grain (see NDS•2.3.11).
- **C_c , Curvature Factor.** Applies only to curved portions of glued laminated bending members (see NDS•5.3.4).
- **C_f , Form Factor.** Applies where bending members are either round or square with diagonal loading (see NDS•2.3.8).

5.2.4.1 Load Duration Factor (C_D)

Lumber strength is affected by the cumulative duration of maximum variable loads experienced during the life of the structure. In other words, strength is affected by both the load intensity and its duration (that is, the load history). Because of its natural composition, wood is better able to resist higher short-term loads (transient live loads or impact loads) than long-term loads (dead loads and sustained live loads). Under impact loading, wood can resist about twice as much stress as the standard 10-year load duration (that is, “normal duration”) to which wood bending stress properties are normalized in the NDS.

When other loads with different duration characteristics are considered, certain tabulated stresses must be modified by a load duration factor (C_D), as shown in table 5.2. Values of C_D for various load types are based on the total accumulated time effects of a given type of load during the useful life of a structure. C_D increases with decreasing load duration.

Where more than one load type is specified in a design analysis, the load duration factor associated with the shortest duration load is applied to the entire combination of loads. For the load combination *Dead Load + Snow Load + Wind Load*, for example, C_D is equal to 1.6.

TABLE 5.2**Recommended Load Duration Factors for ASD**

Load Type	Load Duration	Recommended C_D Value
Permanent (dead load)	Lifetime	0.9
Normal	10 years	1.0
Occupancy (live load)	10 years to 7 days	1.0
Snow	1 month to 7 days	1.15
Temporary construction	7 days	1.25
Wind and seismic ¹	10 minutes to 1 minute	1.6
Impact	1 second	2.0

ASD = allowable stress design.

¹The NDS uses a wind and seismic load duration of 10 minutes ($C_D = 1.6$). The factor may be as high as 1.8 for earthquake loads, which generally have a duration of less than one minute with a much shorter duration for ground motions in the design-level range.

Source: Based on NDS•2.3.2 and NDS•appendix B (AWC, 2012b)

5.2.4.2 Repetitive Member Factor (C_r)

When three or more parallel dimension lumber members are spaced a maximum of 24 inches on center and connected with structural sheathing, they constitute a structural “system” with more bending capacity than the sum of the single members acting individually. Most elements in a house structure benefit from an adjustment for the system strength effects inherent in repetitive members.

The tabulated design values given in the NDS are based on single members; thus, an increase in allowable stress is permitted in order to account for repetitive members. Although the NDS recommends a repetitive member factor of 1.15, or a 15-percent increase in bending strength, system assembly tests have demonstrated that the NDS repetitive member factor is conservative for certain conditions. In fact, test results from several studies support the range of repetitive member factors shown in table 5.3 for certain design applications. As shown in table 5.1, the adjustment factor applies only to extreme fiber in bending, F_b . Later sections of chapter 5 cover other system adjustments related to concentrated loads, header framing assemblies, and deflection (stiffness) considerations.

TABLE 5.3 *Recommended Repetitive Member Factors for Dimension Lumber Used in Framing Systems^{1,2}*

Application	Recommended C_r Value	References
Two adjacent members sharing load ³	1.1 to 1.2	AWC, 2012b HUD, 1999
Three adjacent members sharing load ³	1.2 to 1.3	ASAE, 1997
Four or more adjacent members sharing load ³	1.3 to 1.4	ASAE, 1997
Three or more members spaced not more than 24 inches on center, with suitable surfacing to distribute loads to adjacent members (for example, decking, panels, boards,) ⁴	1.15	AWC, 2012a
Wall framing (studs) of three or more members spaced not more than 24 inches on center, with minimum 3/8-inch thick wood structural panel sheathing on one side and 1/2-inch thick gypsum board on the other side ⁵	1.5—2x4 or smaller 1.35—2x6 1.25—2x8 1.2—2x10	AWC, 2012a Polensek, 1975

¹The *National Design Specification for Wood Construction* (NDS) recommends a C_r value of 1.15 only as shown in the table. The other values in the table were obtained from various codes, standards, and research reports, as indicated.

²Dimension lumber bending members are to be parallel to each other, continuous (not spliced), and of the same species, grade, and size. The applicable sizes of dimension lumber range from 2x4 to 2x12.

³ C_r values are given as a range and are applicable to built-up columns and beams formed of continuous members with the strong axis of all members oriented identically. In general, a larger value of C_r should be used for dimension lumber materials that have a greater variability in strength (that is, the more variability in strength of individual members, the greater the benefit realized in forming a built-up member relative to the individual member strength). A two-ply built-up member of No. 2 grade (visually graded) dimension lumber may qualify for use of a C_r value of 1.2, for example, whereas a two-ply member of No. 1 dense or mechanically graded lumber may qualify for a C_r value of 1.1. The individual members should be adequately attached to one another or the load introduced to the built-up member so that the individual members act as a unit (that is, all members deflect equally) in resisting the bending load. For built-up bending members with noncontinuous plies (that is, splices), refer to ASAE EP 559 (ASAE, 1997). For built-up columns subject to weak axis bending load or buckling, refer to ASAE EP 559 and NDS•15.3.

⁴Refer to NDS•4.3.4 and the *NDS Commentary* for additional guidance on using the 1.15 repetitive member factor.

⁵The C_r values are based on wood structural panel attachment to wall framing using 8d common nails spaced at 12 inches on center. For fasteners of a smaller diameter, multiply the C_r values by the ratio of the nail diameter to that of an 8d common nail (0.131 inch diameter). The reduction factor applied to C_r need not be less than 0.75, and the resulting value of C_r should not be adjusted to less than 1.15. Doubling the nailing (that is, decreasing the fastener spacing by one-half) can increase the C_r value by 16 percent (Polensek, 1975).

With the exception of the 1.15 repetitive member factor, the NDS does not recognize the values in table 5.3; therefore, the values in table 5.3 are provided as information to the designer for an alternative method based on various sources of technical information, including certain standards, code-recognized guidelines, and research studies. The designer may pursue the alternative method approach using section 104.11 of the IRC (ICC, 2012). For more information on system effects, the following references may be helpful.

- “Structural Performance of Light-Frame Truss-Roof Assemblies” (Wolfe, 1991).
- “Performance of Light-Frame Redundant Assemblies” (Wolfe, 1990).
- “Reliability of Wood Systems Subjected to Stochastic Live Loads” (Rosowsky and Ellingwood, 1992).
- “System Effects in Wood Assemblies” (Douglas and Line, 1996).

- *Design Requirements and Bending Properties for Mechanically Laminated Columns (EP 559)* (ASAE, 1997).
- *System Performance of Wood Header Assemblies* (HUD, 1999).
- *Wall & Floor Systems: Design and Performance of Light-Frame Structures* (FPRS, 1983).

5.2.4.3 Other Stress Adjustment Factors

Other stress adjustment factors may be applied for a variety of stress conditions and design situations. Those adjustment factors consider shear, lumber sizes, column stability, beam stability, and others listed in section 5.2.4. The designer should refer to the latest version of the NDS (AWC, 2012b) because the adjustment factors and design conditions for which they apply are reevaluated frequently. The NDS Commentary could be helpful in understanding the derivation of the adjustment factors and how they are applied to the structural design.

5.3 Structural Evaluation

As with any structural design, the designer should perform several checks with respect to various design factors. This section provides an overview of checks specified in the NDS and specifies several design concerns that are not addressed by the NDS. In general, the two categories of structural design concerns are as follows:

Structural Safety (Strength)

- Bending and lateral stability
- Horizontal shear
- Bearing
- Combined bending and axial loading
- Compression and column stability
- Tension
- Connections

Structural Serviceability

- Deflection from bending
- Lateral drift from seismic or wind effects
- Floor vibration
- Shrinkage
- Deterioration

The serviceability issues could be described as possible performance issues or conditions that must be considered in the design. The body of work related to serviceability is not large, thus the designer will need to do some research on these issues and apply judgment based on the research to determine how to approach designs for serviceability. Clients are increasingly becoming

more insistent that their home perform under a variety of load conditions over an extended period of time. Issues related to serviceability will be increasingly important to the designer.

The remainder of this chapter applies those design checks to examples of different structural systems and elements in a home. In addition, given that the intent of this guide is to provide supplemental instruction for the use of the NDS in the efficient design of wood-framed homes, the reader is referred to the NDS for symbol definitions, as well as other guidance.

5.3.1 Structural Safety Checks

Bending (Flexural) Capacity

The following equations from the NDS determine if a wood member has sufficient bending strength. Notches in bending members should be avoided, but small notches are permissible; refer to NDS•3.2.3. Similarly, the diameter of holes in bending members should not exceed one-third the member's depth and should be located along the center line of the member. Increasing member depth, decreasing the clear span or spacing of the member, or selecting a grade and species of lumber with a higher allowable bending stress may yield greater flexural capacity. Engineered wood products or alternative materials may also be considered.

NDS•3.3

$$f_b \leq F'_b \quad \text{basic design check for bending stress}$$

$$F'_b = F_b \times \quad \text{(applicable adjustment factors, per section 5.2.4)}$$

$$f_b = \frac{Mc}{I} = \frac{M}{S} \quad \text{extreme fiber bending stress caused by bending moment from transverse load}$$

$$S = \frac{I}{c} = \frac{bd^2}{6} \quad \text{section modulus of rectangular member}$$

$$I = \frac{bd^3}{12} \quad \text{moment of inertia of rectangular member}$$

$$c = \frac{1}{2}d \quad \text{distance from extreme fiber to neutral axis}$$

Horizontal Shear

Because shear parallel to grain (that is, horizontal shear) is induced by bending action, it is also known as bending shear and is greatest at the neutral axis. Bending shear is not transverse shear; lumber will always fail in other modes before failing in transverse or cross-grain shear because of the longitudinal orientation of the wood fibers in structural members.

The horizontal shear force is calculated for solid sawn lumber by including the component of all loads (uniform and concentrated) that act perpendicular to the bearing surface of the solid member, in accordance with

NDS•3.4.3. Loads within a distance, d , from the bearing point are not included in the horizontal shear calculation; d is the depth of the member for solid rectangular members. Transverse shear is not a required design check, although it is used to determine the magnitude of horizontal shear by using basic concepts of engineering mechanics, as discussed herein.

The following equations from NDS•3.4 for horizontal shear analysis are limited to solid flexural members, such as solid sawn lumber, glulam, or mechanically laminated beams. Notches in beams can reduce shear capacity and should be considered in accordance with NDS•3.4.4. Also, bolted connections influence the shear capacity of a beam; refer to NDS•3.4.5. If required, greater horizontal shear capacity may be obtained by increasing member depth or width, decreasing the clear span or spacing of the member, or selecting another species with a higher allowable shear capacity. The general equation for horizontal shear stress is discussed in the NDS and in mechanics of materials textbooks. Because dimension lumber is solid and rectangular, the simple equation for f_v is most commonly used.

NDS•3.4

$$f_v \leq F'_v \quad \text{basic design check for horizontal shear}$$

$$F'_v = F_v \times \quad \text{(applicable adjustment factors per section 5.2.4)}$$

$$f_v = \frac{VQ}{Ib} \quad \text{horizontal shear stress (general equation)}$$

$$f_v = \frac{3V}{2A} \quad \text{for maximum horizontal shear stress at the neutral axis of solid rectangular members}$$

Compression Perpendicular to Grain (Bearing)

For bending members bearing on wood or metal, a minimum bearing of 1.5 inches typically is recommended. For bending members bearing on masonry, a minimum bearing of 3 inches typically is advised. The resulting bearing areas may not be adequate in the case of heavily loaded members, however. On the other hand, they may be too conservative in the case of lightly loaded members. The minimum bearing lengths represent good practice.

The following equations from the NDS are based on net bearing area. Note that the provisions of the NDS acknowledge that the inner bearing edge experiences added pressure as the member bends. As a practical matter, the added pressure does not pose a problem because the compressive capacity, $F'_{c\perp}$, of wood increases as the material is compressed. Further, the design value is based on a deformation limit, not on failure by crushing. The NDS thus recommends the added pressure at bearing edges not be considered. The designer is also alerted to the use of the bearing area factor, C_b , which accounts for the ability of wood to distribute large stresses originating from a small bearing area not located near the end of a member. Examples include interior bearing supports and compressive loads on washers in bolted connections.

NDS•3.10

$$f_{c\perp} \leq F'_{c\perp} \quad \text{basic design check for compression perpendicular to grain}$$

$$F'_{c\perp} = F_{c\perp} \times \text{(applicable adjustment factors per section 5.2.4)}$$

$$f_{c\perp} = \frac{P}{A_b} \quad \text{stress perpendicular to grain caused by load, P, on net bearing area, } A_b.$$

The above equations pertain to bearing that is perpendicular to grain; for bearing at an angle to grain, refer to NDS•3.10. The latter condition would apply to sloped bending members (such as rafters) notched at an angle for bearing.

Combined Bending and Axial Loading

Depending on the application and the combination of loads considered, some members, such as wall studs and roof truss members, experience bending stress in addition to axial loading. The designer should evaluate combined bending and axial stresses as appropriate. If additional capacity is required, the selection of a higher grade of lumber is not always an efficient solution for overstressed compression members under combined axial and bending loads because the design may be limited by stability rather than by a stress failure mode. Efficiency issues will become evident when the designer calculates the components of the combined stress interaction equations that follow and that are found in the NDS.

NDS•3.9

Combined bending and axial tension design check

$$\frac{f_t}{F'_t} + \frac{f_b}{F_b^*} \leq 1$$

$$\frac{f_b - f_t}{F_b^{**}} \leq 1$$

Combined bending and axial compression design check

$$\left(\frac{f_c}{F'_c}\right)^2 + \frac{f_{b1}}{F'_{b1}\left(1 - \frac{f_c}{F_{cE1}}\right)} + \frac{f_{b2}}{F'_{b2}\left(1 - \left(\frac{f_c}{F_{cE2}}\right) - \left(\frac{f_{b1}}{F_{bE}}\right)^2\right)} \leq 1$$

Compression and Column Stability

For framing members that support axial loads only (that is, columns), the designer must consider whether the framing member can withstand the axial compressive forces on it without buckling or compressive failure. If additional compression strength is required, the designer should increase member size, decrease framing member spacing, provide additional lateral support, or select a different grade and species of lumber with higher allowable stresses. Improving lateral support is usually the most efficient solution when stability controls the design (disregarding any architectural limitations). The need for improved lateral

support will become evident when the designer performs the calculations necessary to determine the stability factor, C_p , in accordance with NDS•3.7. When a column has continuous lateral support in two directions, buckling is not an issue, and $C_p = 1.0$. If, however, the column is free to buckle in one or more directions, C_p must be evaluated for each direction of possible buckling. The evaluation must also consider the spacing of intermediate bracing, if any, in each direction.

NDS•3.7

$$f_c \leq F'_c \quad \text{basic design check for compression parallel to grain}$$

$$F'_c = F_c \times \text{(applicable adjustment factors from section 5.2.4, including } C_p)$$

$$f_c = \frac{P}{A} \quad \text{compressive stress parallel to grain caused by axial load, P, acting on the member's cross-sectional area, A.}$$

$$C_p = \frac{1 + \left(\frac{F_{cE}}{F_c^*} \right)}{2c} - \sqrt{\left[\frac{1 + \left(\frac{F_{cE}}{F_c^*} \right)}{2c} \right]^2 - \frac{F_{cE}}{F_c^*}} \quad \text{column stability factor}$$

$$F_{cE} = \frac{K_{cE} E'}{\left(\ell_c / d \right)^2}$$

$$F_c^* = F_c \times \text{(same adjustment factors for } F'_c \text{ except } C_p \text{ is not used)}$$

K_{cE} of approximately 0.6 may be justified for use with columns that are not individual columns but are instead part of a repetitive system of columns (for example, studs). Although the NDS is silent on this matter, this approach to column design is consistent with the use of C_r for repetitive member stud design. In effect, the modulus of elasticity of a system of columns in a repetitive member system should not be based on a lower bound modulus of elasticity of a single member.

Tension

Relatively few members in light-frame construction resist tension forces only. One notable exception occurs in roof framing, in which cross-ties or bottom chords in trusses primarily resist tension forces. Other examples include chord and collector members in shear walls and horizontal diaphragms, as discussed in chapter 6. Another possibility is a member subject to excessive uplift loads, such as those produced by extreme wind. In any event, connection design usually is the limiting factor in designing the transfer of tension forces in light-frame construction (refer to chapter 7). Tension stresses in wood members can be checked by using the following equations, in accordance with NDS•3.8.

NDS•3.8

$$f_t \leq F'_t \quad \text{basic design check for tension parallel to grain}$$

$$F'_t = F_t \times \text{(applicable adjustment factors per section 5.2.4)}$$

$$f_t = \frac{P}{A} \quad \text{stress in tension parallel to grain caused by axial tension load, } P, \text{ acting on the member's cross-sectional area, } A$$

The NDS does not provide explicit methods for evaluating cross-grain tension forces and generally recommends the avoidance of cross-grain tension in lumber, even though the material is capable of resisting limited cross-grain stresses. Design values for cross-grain tension may be approximated using one-third of the unadjusted horizontal shear stress value, F_v .

One application of cross-grain tension in design is in the transfer of moderate uplift loads from wind through the band or rim joist of a floor to the construction below. If additional cross-grain tension strength is required, the designer should increase member size or consider alternative construction details that reduce cross-grain tension forces. When excessive tension stress perpendicular to grain cannot be avoided, the use of mechanical reinforcement or design detailing to reduce the cross-grain tension forces is considered good practice (particularly in high-hazard seismic regions) to ensure that brittle failures do not occur.

5.3.2 Structural Serviceability

Deflection Caused by Bending

The NDS does not specifically limit deflection but rather defers to designer judgment or building code specifications. Nonetheless, with many interior and exterior finishes susceptible to damage by large deflections, this guide recommends reasonable deflection limits based on design loads for the design of specific elements.

The calculation of member deflection is based on the section properties of the beam from NDS-S and the member's modulus of elasticity, with applicable adjustments. Generally, a deflection check using the following equations is based on the estimated maximum deflection under a specified loading condition. Given that wood exhibits time- and load-magnitude-dependent permanent deflection (creep), the total long-term deflection can be estimated using terms of two components of the load that relate to short- and long-term deflection, based on recommendations provided in NDS•3.5.

$$\Delta_{\text{estimate}} \leq \Delta_{\text{allow}} = \frac{\ell}{(120 \text{ to } 600)} \quad (\text{see table 5.4 for value of denominator})$$

$$\Delta_{\text{estimate}} \cong f\left(\frac{\text{load and span}}{EI}\right) \quad (\text{see beam equations in appendix A})$$

If a deflection check proves unacceptable, the designer may increase member depth, decrease the clear span or spacing of the member, or select a grade and species of wood with a higher modulus of elasticity. Typical denominator values used in the deflection equation range from 120 to 600, depending on application and designer judgment. Table 5.4 provides recommended deflection limits. Certainly, if a modest adjustment to a deflection limit results in a more efficient design, the designer should exercise discretion with respect to a possible negative consequence, such as vibration or long-term creep. For lateral bending loads on walls, a serviceability load for a deflection check may be determined from serviceability wind design maps in ASCE 7-10 (ASCE, 2010) and wind design pressures calculated using ASCE 7 formulas. Alternatively, ASCE 7-10 basic wind speeds may be used to determine a 700-year (ultimate) wind load, then reduced by a factor of 0.42 to a service-load level.

TABLE 5.4 *Recommended Allowable Deflection Limits¹*

Element or Condition	Deflection Limit ²	Load Condition
Rafters without attached ceiling finish	$\ell/180$	L _r or S
Rafters with attached ceiling finishes and trusses	$\ell/240$	L _r or S
Ceiling joists with attached finishes	$\ell/240$	L _{attic}
Roof girders and beams	$\ell/240$	L _r or S
Exterior walls and interior partitions		
With plaster or stucco finish	$\ell/360$	W ⁵ or E
With other brittle finishes	$\ell/240$	W ⁵ or E
With interior gypsum board	$\ell/180$	W ⁵ or E
Headers	$\ell/240$	(L _r or S) or L
Floors ³	$\ell/360$	L
Floor girders and beams ⁴	$\ell/360$	L

¹Values may be adjusted according to designer discretion with respect to potential increases or decreases in serviceability. In some cases, a modification may require local approval of a code variance. Some deflection checks may be different or not required, depending on the local code requirements. The load condition includes the live or transient load only, not the dead load.

² ℓ is the clear span in units of inches for deflection calculations.

³Floor vibration may be controlled by using $\ell/360$ for spans up to 15 feet and a 1/2-inch limit for spans greater than 15 feet. Wood I-joist manufacturers typically recommend $\ell/480$ as a deflection limit to provide enhanced floor performance and to control nuisance vibrations.

⁴Floor vibration may be controlled for combined girder and joist spans of greater than 20 feet by use of a $\ell/480$ to $\ell/600$ deflection limit for the girder.

⁵The wind load is 0.42 times the component and cladding loads determined from ASCE 7-10.

System effects can influence the stiffness of assemblies in a manner similar to that of bending capacity (see section 5.3.1). The estimated deflection based on an analysis of an element (for example, stud or joist) is multiplied by

system deflection factors to account for system effect. Typical deflection checks on floors under uniform loading can be easily overestimated by 20 percent or more. When concentrated loads are considered on typical light-frame floors with wood structural panel subflooring, deflections can be overestimated by a factor of 2.5 to 3 because of the neglect of the load distribution to adjacent framing members and partial composite action (Tucker and Fridley, 1999). When adhesives attach wood structural panels to wood framing, even greater reductions in deflection are realized because of increased composite action (Gillespie, Countryman, and Blomquist, 1978; Pellicane and Anthony, 1996). Reductions in expected deflections based on system effects do not comply with IRC Table R301.7, and the designer should research any deflection reductions to ensure that the condition of interest accurately represents the design condition.

Floor Vibration

The NDS does not specifically address floor vibration because it is seen as a serviceability rather than a safety issue. In addition, what is considered an “acceptable” amount of floor vibration is highly subjective. Accordingly, reliable design information on controlling floor vibration to meet a specific level of “acceptance” is not readily available. The following rules of thumb are provided for the designer who wants to limit vibration beyond that implied by the traditional use of a $\ell/360$ deflection limit (ATC, 1999; Woeste and Dolan, 1998).

- For floor joist spans less than 15 feet, a deflection limit of $\ell/360$ considering design live loads only may be used, where ℓ is the clear span of the joist in inches.
- For floor joist clear spans greater than 15 feet, the maximum deflection should be limited to 0.5 inches.
- For wood I-joists, the manufacturer’s tables that limit deflection to $\ell/480$ should be used for spans greater than 15 feet, where ℓ is the clear span of the member in inches.
- When calculating deflection based on the preceding rules of thumb, the designer should use a 40 pounds-per-square-foot (psf) live load for all rooms—whether or not they are considered sleeping rooms.
- As an additional recommendation, the floor sheathing may be glued and mechanically fastened to the floor joists to enhance the floor system’s strength and stiffness.

Floor deflections typically are limited to $\ell/360$ in the span tables published in current building codes using a standard deflection check without consideration of system effects. For clear spans greater than 15 feet, this deflection limit has caused nuisance vibrations that are unacceptable to some building occupants or owners. Floor vibration also is aggravated when the floor is supported on a bending member (for example a girder) rather than on a rigid bearing wall. It may be desirable to design such girders with a smaller deflection limit to control floor

vibration, particularly when girder and floor spans have more than a 20-foot total combined span (that is, span of girder plus span of supported floor joist).

A frequently occurring nuisance vibration in residential structures is that caused by the operation of mechanical equipment, such as washing machines, electrical generators, and water circulating pumps. This equipment usually can be installed on vibration isolators to help reduce or even eliminate vibration.

For metal-plate-connected wood trusses, strongbacks are effective in reducing floor vibration when they are installed through the trusses near the center of the span. A strongback is a continuous bracing member, typically a 2x6, fastened edgewise to the base of the vertical web of each truss with two 16d nails. For longer spans, strongbacks may be spaced at approximately 8-foot intervals across the span. Details for strongbacks may be found in the *Metal Plate Connected Wood Truss Handbook* (Callahan, 2004). Alternatively, more stringent deflection criteria may be used for the floor truss design.

Shrinkage

The amount of wood shrinkage in a structure depends on the MC of the lumber at the time of installation relative to the EMC that the wood will ultimately attain in use. Shrinkage is also dependent on the detailing of the structure, such as the amount of lumber supporting loads in a perpendicular-to-grain orientation (for example, sills, soles, top plates, and joists). MC at installation is a function of the specified drying method, jobsite storage practices, and climate conditions during construction. Relatively dry lumber (15 percent or less MC) minimizes shrinkage problems affecting finish materials and prevents loosening or stressing of connections. A less favorable but acceptable alternative is to detail the structure in such a way that shrinkage is uniform, dispersed, or otherwise designed to minimize problems. This alternative is the de facto choice in simple residential buildings.

Shrink and swell across the width or thickness of lumber can be estimated by the equation below from ASTM D1990 for typical softwood structural lumber (ASTM, 2007). Shrinkage in the longitudinal direction of the member is negligible (FPL, 2010).

ASTM D1990•App. X.1

$$d_2 = d_1 \left(\frac{1 - \frac{a - 0.2M_2}{100}}{1 - \frac{a - 0.2M_1}{100}} \right)$$

d_1 = member width or thickness at moisture content M_1
 d_2 = member width or thickness at moisture content M_2

Lateral Drift

Drift can be both a perception of motion problem and a collapse prevention issue from the P-delta effect. Drift can occur from either high winds or a seismic event. The problem of motion perception is certainly a serviceability issue but is not likely in high winds unless the structure has a height-to-plan ratio that would increase the building's susceptibility to motion. The literature provides little guidance on how to determine lateral drift caused by wind. The International Building Code (IBC) has lateral drift equations for earthquakes, but, again unless the height-to-plan ratio is extremely high, drift usually is not a problem for residential structures. Defining the expected performance of the building with respect to motion could assist the designer in determining what design issues must be considered. For wind, a building with a large height-to-plan ratio and large glass areas near the top of the building would suggest the need to limit lateral deflection to prevent the glass from cracking and to reduce the perception of excessive lateral movement by the building occupants. For earthquake-induced motion, drifts also have been shown to correlate well with structural and nonstructural (for example, gypsum wall board) damage. Decreasing lateral drift, particularly that caused by shear (rather than overturning), is helpful in reducing damage following even moderate earthquakes.

Deterioration

Deterioration that affects serviceability is most likely to occur in places that would (1) allow water penetration into the building; (2) allow an increase in deflection or drift; (3) allow crushing of wood sill plates or wall bottom plates, which could create interior cracks in the finishes; or (4) push the exterior wall surface out, causing another potential place to trap water or, at a minimum, cause an unsightly bulge. Deterioration also can create structural stability problems if left unattended.

The designer can help prevent issues with deterioration by using wood that will not decay in the presence of moisture and by designing good detailing that will help ensure that water management techniques are employed to keep water outside the building envelope and away from the interior of the building. Many references are available that offer best-practices for minimizing deterioration in wood-framed buildings. One such reference that has comprehensive coverage of this issue is *Moisture Resistant Homes* (HUD, 2006).

5.4 Floor Framing

The objectives of good floor system design are—

- To support occupancy live loads and building dead loads adequately.
- To resist lateral forces resulting from wind and seismic loads and to transmit the forces to supporting shear walls through the diaphragm action provided by the floors.

- To provide a suitable subsurface for floor finishes.
- To resist vibration and excessive deflection or “bounce.”
- To serve as a thermal barrier over unconditioned areas (for example, crawl spaces).
- To serve as a noise barrier from people living below.
- To provide a one- to two-hour fire rating between dwelling units in multifamily buildings (refer to local building codes).

5.4.1 General

A wood floor is a horizontal structural system composed primarily of (1) joists, (2) beams or girders, and (3) sheathing.

Wood floor systems traditionally have been built of solid sawn lumber for floor joists and girders, but parallel chord wood trusses and wood I-joists are experiencing substantial market share, offering advantages for dimensional consistency and spans. Floor joists are horizontal, repetitive framing members that support the floor sheathing and transfer the live and dead floor loads to the walls, beams or girders, or columns below. Beams and girders are horizontal members that support floor joists not otherwise supported by interior or exterior load-bearing walls. Floor sheathing is a horizontal structural element—usually plywood or OSB panels—that directly supports floor loads and distributes them to the framing system below. Floor sheathing also provides lateral support to the floor joists. As a structural system, the floor provides resistance to lateral building loads resulting from wind and seismic forces and thus constitutes a “horizontal diaphragm” (refer to chapter 6). See figure 5.2 for an illustration of floor system structural elements.

FIGURE 5.2

Structural Elements of the Floor System

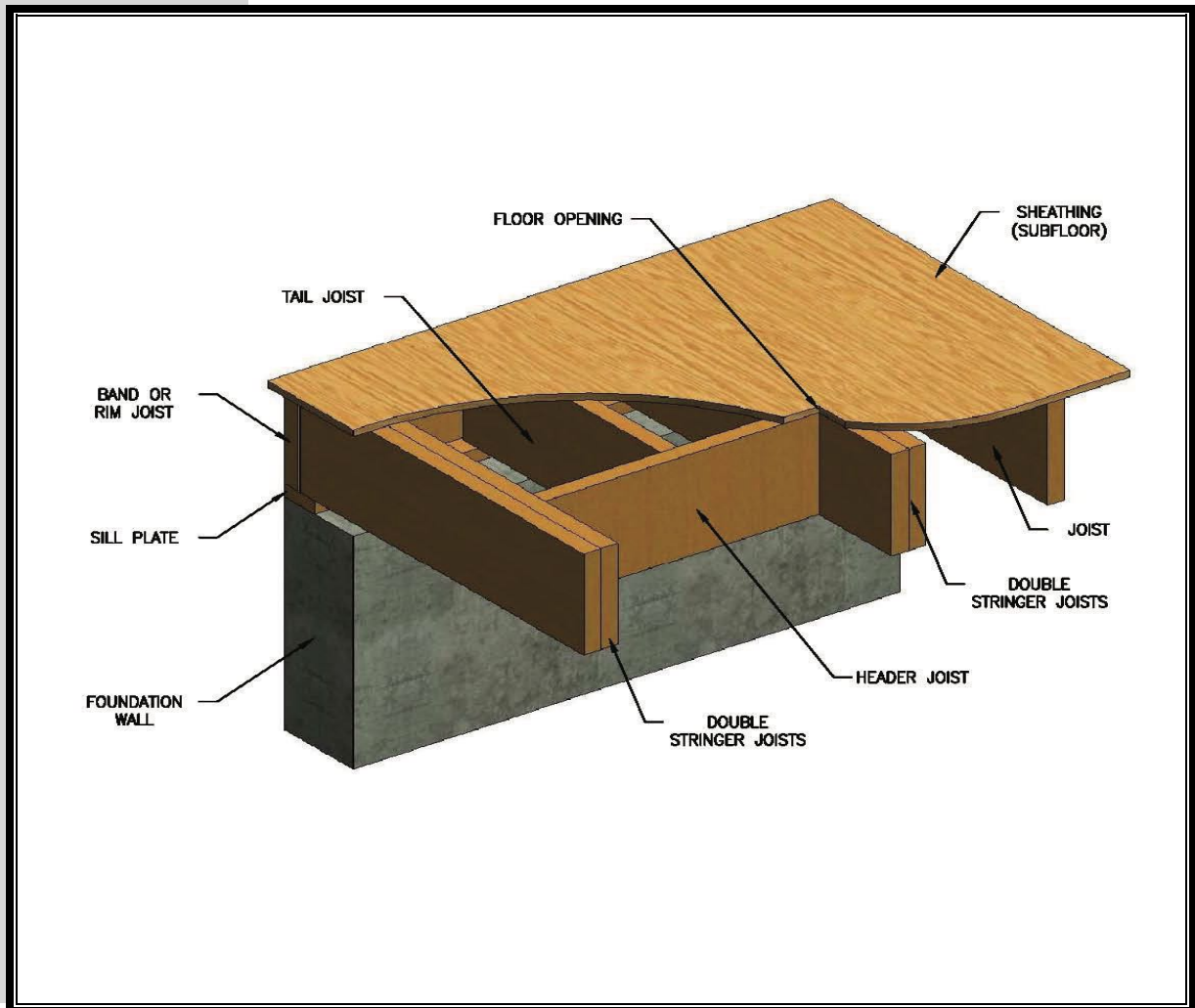

The design approach discussed herein addresses solid sawn lumber floor systems in accordance with the procedures specified in the NDS, with appropriate modifications as noted. For more information regarding wood I-joists, trusses, and other materials, consult the manufacturer's specifications and applicable code evaluation reports.

Section 5.3 discusses the general design equations and design checks for the NDS. This section provides detailed design examples that apply the equations in section 5.3, tailoring them to the design of elements in a floor system. The next sections refer to the span of a member. The NDS defines span as the clear span of the member plus one-half the required bearing at each end of the member. This guide simply defines span as the distance between the bearing points along the center line. This is somewhat easier to determine and is a more conservative definition than that of the NDS.

When designing any structural element, the designer must first determine the loads acting on the element. Load combinations used in the analysis of floor

members in this guide are taken from table 3.1 of chapter 3. Given that only the dead loads (D) of the floor system and live loads (L) of occupancy are present in a typical floor system, the controlling design load combination for a simply supported floor joist is D+L. Although the standard live loads for living and sleeping areas have been developed and are in both the building code and ASCE 7, the designer should explore with the building's owners how the space is to be used and consider any unusual loading as part of the design. Those unusual conditions might include large whirlpool bathtubs, hot tubs, floors used for exercise or weightlifting, or floors used for business. For joists with more complicated loading, such as cantilevered joists supporting roof framing, the following load combinations may be considered in accordance with chapter 3 and table 3.4:

$$D + L$$
$$D + 0.75L + 0.75 (L_r \text{ or } S)$$

5.4.2 Floor Joist Design

Readily available tables in residential building codes provide maximum allowable spans for different species, grades, sizes, and spacing of floor joists; therefore, designing conventional floor joists for residential construction is usually unnecessary. To obtain greater economy or performance, however, designers may wish to create their own span tables or spreadsheets for future use, in accordance with the methods shown in this section. Many of the established span limits are set by the deflection limits of the building code and not strictly by the loads imposed. Joist spans are set using only uniform dead and live loads; no concentrated loads are included.

Designers should keep in mind that the grade and species of lumber are often a regional choice governed by economics and availability. Some of the most common species of lumber for floor joists are Hem-Fir, Spruce-Pine-Fir, Douglas-Fir, and Southern Yellow Pine. The most common sizes for floor joists are 2x8, 2x10, and 2x12. Examples 5.1 and 5.2 in section 5.7 illustrate the design of typical floor joists, in accordance with the principles discussed earlier.

For different joist applications, such as a continuous multiple span, the designer should use the appropriate beam equations (refer to appendix A) to estimate the stresses induced by the loads and reactions. Other materials such as wood I-joists and parallel chord floor trusses also are commonly used in light-frame residential and commercial construction; refer to the manufacturer's data for span tables for wood I-joists and other engineered wood products. Wood floor trusses can be ordered to specification, and they are provided with an engineering certification (that is, stamped shop drawings); cold-formed steel floor joists or trusses may also be considered. Figure 5.3 illustrates some conventional and alternative floor framing members.

FIGURE 5.3

Conventional and Alternative Floor Framing Members

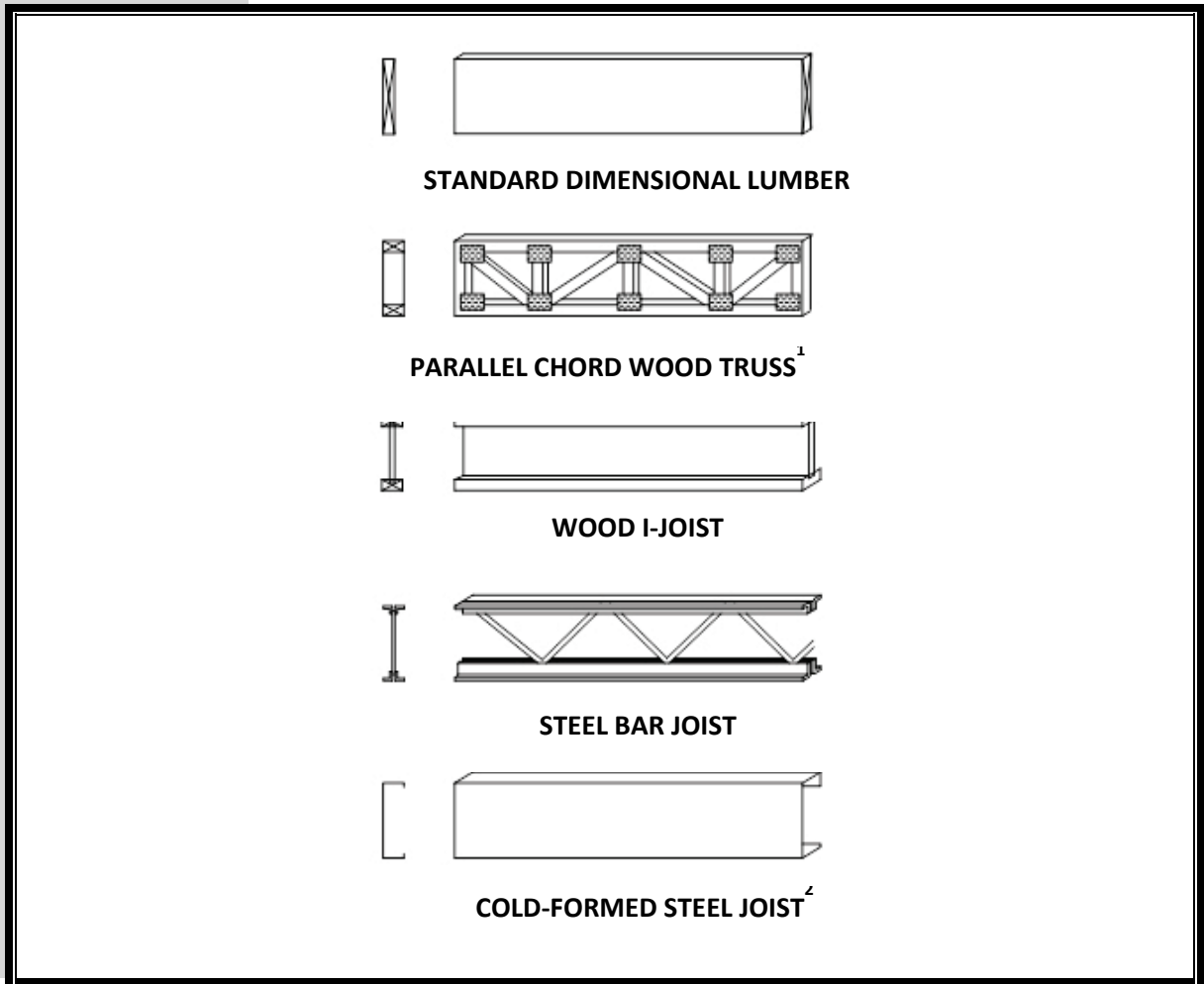

Notes:

¹Trusses are available with trimmable ends.

²Cold-formed steel also is used to make floor trusses.

For typical floor systems supporting a concentrated load at or near center span, load distribution to adjacent joists can substantially reduce the bending stresses or moment experienced by the loaded joist. A currently available design methodology may be beneficial for certain applications such as wood-framed garage floors that support heavy concentrated wheel loads (Tucker and Fridley, 1999). Under such conditions, the maximum bending moment experienced by any single joist is reduced by more than 60 percent. A similar reduction in the shear loading (and end reaction) of the loaded joist also results, with exception for “moving” concentrated loads that may be located near the end of the joist, thus creating a large transverse shear load with a small bending moment. The previously mentioned design methodology for a single, concentrated load applied

near mid-span of a repetitive member floor system is essentially equivalent to using a C_r factor of 1.5 or more (see section 5.2.4.2).

Bridging or cross-braces were formerly thought to provide both necessary lateral-torsional bracing of dimension lumber floor joists and stiffer floor systems. Full-scale testing of 10 different floor systems, however, as well as additional testing in completed homes, has conclusively demonstrated that bridging or cross-bracing provides negligible benefit to either the load-carrying capacity or stiffness of typical residential floors with dimension lumber framing (sizes of 2x6 through 2x12) and wood structural panel subflooring (NAHB, 1961). Those findings have not been proven to apply to other types of floor joists (for example, I-joists and steel joists) or for dimension lumber joists greater than 12 inches in depth. According to the study, bridging may be considered necessary for 2x10 and 2x12 dimension lumber joists with clear spans exceeding about 16 feet and 18 feet, respectively (based on a 50 psf total design load and $l/360$ deflection limit). The bottom of long span joists has a tendency to buckle slightly or move out of plane. Bridging helps to prevent the tendency to buckle, and it helps provide the joist with a straight bottom on which to nail drywall or other ceiling materials from the space below the floor. The beam stability provisions of NDS•4.4.1 require bridging to be spaced at intervals not exceeding 8 feet along the span of 2x10 and 2x12 joists.

5.4.3 Beam and Girder Design

The decision to use one girder (throughout this guide, the terms *beam* and *girder* are used interchangeably) over another is a function of cost, availability, span and loading conditions, deflection limits, clearance or headroom requirements, and ease of construction. Refer to figure 5.4 for illustrations of girder types. Girders in residential construction usually are one of the following types.

- Built-up dimension lumber.
- Steel I-beam.
- Engineered wood beam (such as laminated veneer lumber, glulam, or parallel strand lumber).
- Site-fabricated beam (such as plywood I-beam, plywood box beam and flitch plate beam).
- Wood I-joist.
- Metal plate-connected wood truss (such as parallel chord truss).

Built-up beams are constructed by nailing together two or more plies of dimension lumber. Because load sharing occurs between the plies (or lumber members), the built-up girder is able to resist higher loads than a single member of the same overall dimensions. The built-up member can resist higher loads only if butt joints are located at or near supports and are staggered in alternate plies. Each ply may be face nailed to the previous ply with 10d nails staggered at 12 inches on center, top to bottom. The design method and equations are the same as

those in section 5.4.2 for floor joists; however, the adjustment factors applying to design values and loading conditions are somewhat different. The designer needs to keep in mind the following.

- Although floor girders are not typically thought of as “repetitive” members, a repetitive-member factor is applicable if the floor girder is built up from two or more members (three or more, according to the NDS).
- The beam stability factor, C_L , is determined in accordance with NDS•3.3.3; however, for girders supporting floor framing, lateral support is considered to be continuous, and $C_L = 1$.

Figure 5.4 illustrates the design of a built-up floor girder.

FIGURE 5.4

Examples of Beams and Girders

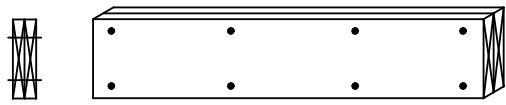

BUILT-UP MEMBER (DIMENSION LUMBER)

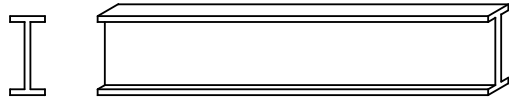

HOT-ROLLED STEEL BEAM
(W-SHAPE)

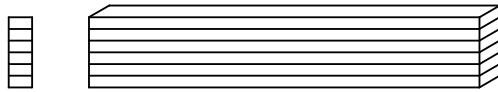

GLUED LAMINATED LUMBER (GLULAM)

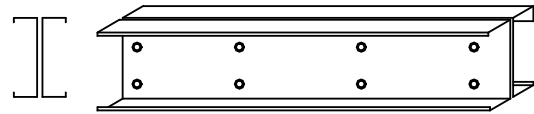

BUILT-UP COLD-FORMED STEEL



LAMINATED VENEER LUMBER (LVL)

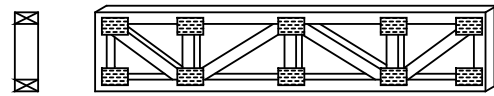

PARALLEL CHORD WOOD TRUSS

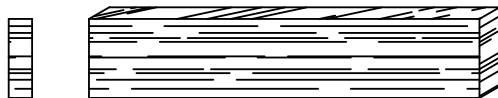

PARALLEL STRAND LUMBER

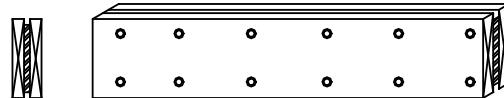

FLITCH PLATE

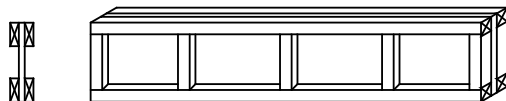

PLYWOOD WEB I-BEAMS
(OR WOOD I-JOIST PER FIGURE 5.3)

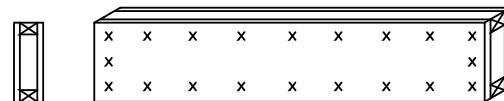

PLYWOOD BOX BEAM

Steel I-beams often are used in residential construction because of their greater spanning capability. Compared with wood members, they span longer distances with a shallower depth, primarily because the allowable bending stress in a steel beam is greater than that of wood by more than a factor of 10. A 2x4 or 2x6 usually is attached to the top surface with bolts to provide a fastening surface for floor joists and other wood structural members. Although steel beam shapes commonly are referred to as I-beams, a typical 8-inch deep, wide flanged W-shaped beam commonly is considered a house beam. Alternatively, built-up cold-formed steel beams (that is, back-to-back C-shapes) may be used to construct I-shaped girders. Refer to the *Steel Construction Manual* (AISC, 2011) and the American Iron and Steel Institute's publication RG-936 for the design of and span tables for residential applications of hot-rolled steel sections (AISI, 1993). Span tables for structural steel floor beams can also be found in the *Beam Series* (NAHBRC, 1981). The *Prescriptive Method for Residential Cold-Formed Steel Framing* (NAHBRC, 1998) and the *North American Standard for Cold-Formed Steel—Prescriptive Method for One and Two Family Dwellings* (AISI, 2012) should be consulted for the design of built-up cold-formed steel sections to be used as headers and girders.).

Engineered wood beams include I-joists, wood trusses (that is, girder trusses), glue-laminated lumber (glulam), laminated veneer lumber, parallel strand lumber, and so forth. This guide does not address the design of engineered wood girders because product manufacturers typically provide span tables or engineered designs that are considered proprietary. Consult the manufacturer for design guidelines or completed span tables. The NDS provides a methodology for the design of glue-laminated beams (NDS•5), however.

Site-fabricated beams include plywood box beams, plywood I-beams or wood I-joist, and flitch plate beams. *Plywood box beams* are fabricated from continuous dimension lumber flanges (typically 2x4 or 2x6) sandwiched between two plywood webs; stiffeners are placed at concentrated loads, end bearing points, plywood joints, and maximum 24-inch intervals. *Plywood I-beams* are similar to box beams except that the plywood web is sandwiched between dimension lumber wood flanges (typically 2x4 or 2x6), and stiffeners are placed at maximum 24-inch intervals.

Flitch plate beams are fabricated from a steel plate sandwiched between two pieces of dimension lumber to form a composite section; thus, a thinner member can be used comparison with a built-up wood girder of similar strength. The steel plate typically is 1/4- to 1/2-inch thick and about 1/4 inch less in depth than the dimension lumber. The sandwich construction usually is assembled with through-bolts staggered at about 12 inches on center. Flitch plate beams derive their strength and stiffness from the composite action of steel plate and dimension lumber joined together. The lumber also provides a medium for fastening other materials using nails or screws.

Span tables for plywood I-beams, plywood box beams, steel-wood I-beams, and flitch plate beams are provided in NAHB's *Beam Series* publications (NAHBRC, 1981). Refer to the APA's *Product Design Specification* (PDS) (APA, 1998a) and *Supplement* (APA, 1998b) for the design method used for

plywood box beams. Section R602.7.2 of the IRC (ICC, 2012), provides a simple prescriptive table for plywood box beam headers.

5.4.4 Subfloor Design

Typical subfloor sheathing is nominal 5/8- or 3/4-inch thick 4x8 panels of plywood or OSB, with tongue-and-groove edges at unsupported joints perpendicular to the floor framing. Sheathing products generally are categorized as wood structural panels and are specified in accordance with the prescriptive span rating tables published in a building code or are made available by the manufacturer. The prescriptive tables provide maximum spans (joist spacing) based on sheathing thickness and span rating, with the standard beam calculation as the basis. If loads exceed the limits shown in the prescriptive tables, the designer may have to perform calculations; however, such calculations are rarely necessary.

The APA also recommends a fastener schedule for connecting sheathing to floor joists. Generally, nails are placed a minimum of 6 inches on center at edges and 12 inches on center along intermediate supports. Table 5.5 lists recommended nail sizes based on sheathing thickness. Nail sizes vary with nail type (for example, sinkers, box nails, and common nails), and various nail types have different characteristics that affect structural properties (refer to chapter 7). For information on other types of fasteners, consult the fastener manufacturer. In some cases, shear loads in the floor diaphragm resulting from lateral loads (that is, wind and earthquake) may require a more stringent fastening schedule; chapter 6 includes a discussion on fastening schedules for lateral load design. Regardless of fastener type, gluing the floor sheathing to the joists increases floor stiffness and strength. Gluing also reduces or eliminates floor squeaks, which result when the unsecured floor sheathing rubs across the top of the floor joist when someone steps on the sheathing.

TABLE 5.5 *Fastening Floor Sheathing to Structural Members¹*

Thickness	Size and Type of Fastener
Plywood and wood structural panels, subfloor sheathing to framing	
1/2 inch and less	6d common nail
19/32 to 1 inch	8d common nail
1-1/8 to 1-1/4 inch	10d common nail or 8d deformed shank nail
Plywood and wood structural panels, combination subfloor/underlayment to framing	
3/4 inch and less	8d common nail or 6d deformed shank nail
7/8 to 1-inch	8d common nail
1-1/8 to 1-1/4 inch	10d common nail or 8d deformed shank nail

Notes:

¹Codes generally require common or box nails; if pneumatic nails are used, as is common, refer to ESR-1539 (ICC-ES, 2013) or the nail manufacturer's data. Screws also are commonly substituted for nails. For more detail on fasteners and connections, refer to chapter 7.

5.5 Wall Framing

The objectives of wall system design are—

- To resist snow, live and dead loads, and wind and seismic forces.
- To provide an adequate subsurface for wall finishes and to provide openings for doors and windows.
- To serve as a thermal and weather barrier.
- To provide space for and access to electrical and mechanical equipment, where required.
- To provide a 1- to 2-hour fire barrier if the wall separates individual dwelling units in attached or multifamily buildings.

5.5.1 General

A wall is a vertical structural system that supports gravity loads from the roof and floors above and transfers the loads to the foundation below. It also resists lateral loads resulting from wind and earthquakes. A typical wood-framed wall is composed of the following elements, as shown in figure 5.5.

- Studs, including wall, cripple, jack, and king studs.
- Top and bottom (sole) plates.
- Headers across openings.
- Sheathing.
- Diagonal let-in braces, if used.

Residential wall systems traditionally have been constructed of dimension lumber, usually 2x4 or 2x6, although engineered wood studs and cold-formed steel studs are seeing increased use. Wall studs are vertical, repetitive framing members spaced at regular intervals to support the wall sheathing. They span the full height of each story and support the building loads above. King and jack studs (also known as jamb studs) frame openings and support loads from a header. Cripple studs are placed above or below a wall opening and are not full height. Built-up wall studs that are assembled on the jobsite may be used within the wall to support concentrated loads. Top and bottom plates are horizontal members to which studs are fastened. The top and bottom plates are then fastened to the floor or roof above and either to the floor below or directly to the foundation. Headers are beams that transfer the loads above an opening to jack studs at each side of the opening. Diagonal let-in bracing can be an alternative to wall sheathing to provide shear resistance for the wall.

FIGURE 5.5

Structural Elements of the Wall System

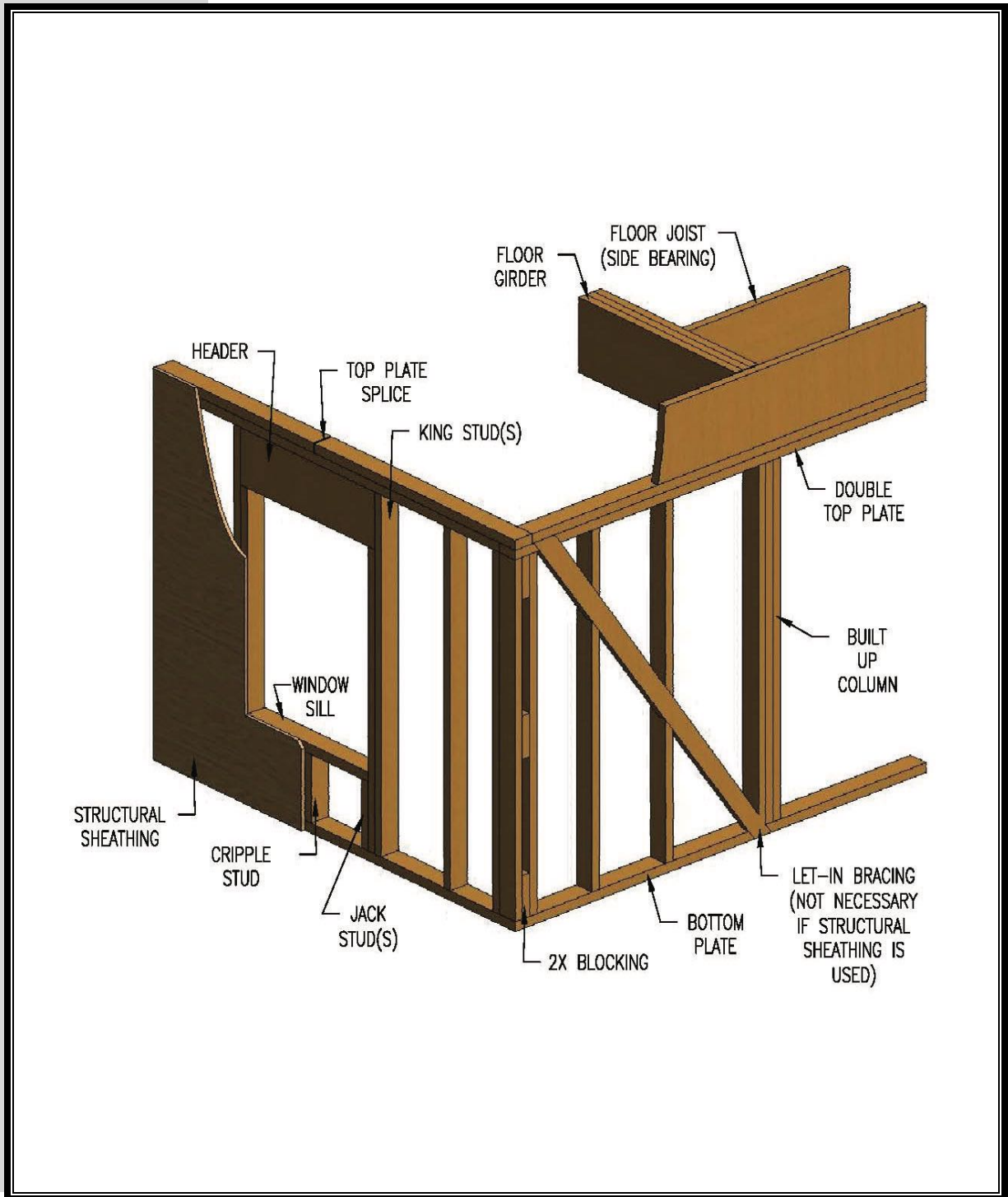

Structural wall sheathing, such as plywood or OSB, distributes lateral loads to the wall framing and provides lateral support to both the wall studs (that is, buckling resistance) and the entire building (that is, racking resistance). Interior

wall finishes also provide significant support to the wall studs and the structure. In low-wind and low-hazard seismic areas, metal T braces or wood let-in braces may be used in place of wall sheathing to provide resistance to lateral (racking) loads. About 80 percent of new homes constructed each year now use wood structural panel bracing, and many of those homes are fully sheathed with wood structural panels. Chapter 6 addresses the design of wall bracing in greater detail.

The design procedure discussed herein addresses dimension lumber wall systems according to the NDS. Where appropriate, modifications to the NDS have been incorporated and are noted. Standard design equations and design checks for the NDS procedure were presented earlier in this chapter. The detailed design examples in this section illustrate the application of the equations by tailoring them to the design of the elements that make up residential wall systems.

Wall systems are designed to withstand dead and live gravity loads acting parallel to the wall stud length, as well as lateral loads—primarily wind and earthquake loads—acting perpendicular to and parallel to the face of the wall. Wind also induces uplift loads on the roof; when the wind load is sufficient to offset dead loads, walls and internal connections must be designed to resist tension or uplift forces. The outcome of the design of wall elements depends on the degree to which the designer uses the “system strength” inherent in the construction. To the extent possible, guidance on system design in this section uses the NDS and the recommendations in sections 5.2 and 5.3.

When designing wall elements, the designer needs to consider the load combinations discussed in chapter 3, particularly the following ASD combinations of dead, live, snow, seismic, and wind loads—

- $D + 0.75L + 0.75(L_r \text{ or } S)$.
- $D + (L_r \text{ or } S)$.
- $D + 0.75L + 0.45W + 0.75(L_r \text{ or } S \text{ or } R)$.
- $D + 0.52E + 0.75L + 0.75S$.

A wall system may support a roof only or a roof and one or more stories above. The roof may or may not include an attic storage live load. A 10 psf attic live load used for the design of ceiling joists is intended primarily to provide safe access to the attic, not support for attic storage. The controlling load combination for a wall that supports only a roof is the second load combination listed above. The controlling load combination for a wall that supports a floor, wall, and a roof should be either the first or second load combination depending on the relative magnitude of floor and roof snow loads.

The third load combination provides a check for the out-of-plane bending condition due to lateral wind loads on the wall. For tall, wood-framed walls that support heavy claddings such as brick veneer, the designer should also consider out-of-plane bending loads resulting from an earthquake load combination, although the other load combinations shown usually control the design. The third and fourth load combinations are essentially combined bending and axial loads that may govern stud design, as opposed to axial load only, considered in the first two load combinations. Chapter 6 addresses the design of walls for in-plane shear

or racking forces resulting from lateral building loads caused by wind or earthquakes.

In many cases, certain design load combinations or load components can be dismissed or eliminated through practical consideration and inspection. They are a matter of designer judgment, experience, and knowledge of the critical design conditions.

5.5.2 Load-Bearing Walls

Exterior load-bearing walls support both axial and lateral loads. For interior load-bearing walls, only gravity loads are considered. A serviceability check using a lateral load of 5 psf is sometimes applied independently to interior walls but should not normally control the design of load-bearing framing. This section focuses on the axial and lateral load-bearing capacity of exterior and interior walls.

Exterior walls are not necessarily always load-bearing walls. Load-bearing walls support gravity loads from the roof, ceiling, or floor joists or the beams above. A gable-end wall typically is considered a non-load-bearing wall because roof and floor framing generally runs parallel to the gable end; however, a gable-end wall must support lateral wind and seismic loads and even small dead and live loads. Exterior load-bearing walls must be designed for axial loads as well as for lateral loads from wind or seismic forces. They must also act as shear walls to resist racking loads from lateral wind or seismic forces on the overall building (refer to chapter 6). Example 5.4 demonstrates the design of an exterior load-bearing wall.

When calculating the column stability factor for a stud wall, column capacity is determined by using the slenderness ratio about the strong axis of the stud $(\ell_e/d)_x$ in accordance with NDS•3.7.1. The strong axis slenderness ratio is used because the wall sheathing and finish materials in the stud's weak-axis bending or buckling direction provide lateral support to the stud. When determining the column stability factor, C_p , for a wall system rather than for a single column, in accordance with NDS•3.7.1, the designer must exercise judgment with respect to the calculation of the effective length, ℓ_e , and the depth or thickness of the wall system, d . A buckling coefficient, K_e , of about 0.8 is reasonable (see appendix G of NDS) and is supported in the research literature on this topic for sheathed wall assemblies and studs with square-cut ends (that is, not a pinned joint).

In cases in which continuous support is not present (such as during construction), the designer may want to consider stability for both axes. Unsupported studs generally fail because of weak-axis buckling under a significantly lighter load than would otherwise be possible with continuous lateral support in the weak-axis buckling direction, which is provided by sheathing.

Interior walls may be either load bearing or non-load bearing. Non-load-bearing interior walls often are called partitions. In either case, interior walls should be solidly fastened to the floor and ceiling framing and to the exterior wall framing where they adjoin. Installing extra studs, blocking, or nailers in the

outside walls may be necessary to provide for attachment of interior walls. The framing also must be arranged to provide a nailing surface for wall-covering materials at inside corners. Interior load-bearing walls typically support the floor or ceiling joists above when the clear span from exterior wall to exterior wall is greater than the spanning capability of the floor or ceiling joists. Interior walls, unlike exterior walls, seldom experience large transverse (that is, out of plane) lateral loads; however, some building codes require interior walls to be designed for a minimum lateral load, such as 5 psf, for serviceability. Some interior load-bearing walls may be shear walls to assist in transferring lateral loads to lower floors and to the foundation. If the interior wall is required only to resist axial loads, the designer may follow the design procedure demonstrated in example 5.4 for the axial-load-only case. Generally, axial load design provides more than adequate resistance to a nominal lateral load.

If local code requirements require wall studs to be designed to withstand a minimum lateral load, the designer should specify load-bearing walls in accordance with the previous section on exterior load-bearing walls. (Note that the load duration factor, C_D , of 1.6 is used for allowable stress increases for exterior load-bearing walls when wind or earthquake loads are considered, whereas a load duration factor of 1.0 to 1.25 may be used for interior load-bearing walls and exterior walls analyzed for live and snow loads; refer to section 5.2.4.1.)

5.5.3 Headers

Load-bearing headers are horizontal members that carry loads from a wall, ceiling, or floor or roof above and transfer the combined load to jack and king studs on each side of a window or door opening. The span of the header may be taken as the width of the rough opening measured between the jack studs supporting the ends of the header. Headers usually are built up from two nominal 2-inch thick members or are engineered wood beams.

Load-bearing header design and fabrication is similar to that for girders (see section 5.4.3). The minimum allowable deflection limit of $\ell/240$ will permit substantial deflection in large openings, which could create a binding on windows and doors. For a 10-foot wide opening, for example, the permissible deflection is 1/2 inch. Large openings or especially heavy loads may require stronger members, such as engineered wood beams, hot-rolled steel, or flitch plate beams.

Headers generally are designed to support all loads from above; however, typical residential construction calls for a double top plate above the header. When an upper story is supported, a floor band joist and sole plate of the wall above also are spanning the wall opening below. These elements are all part of the load-resisting system. Recent header testing was done to determine whether an adjustment factor (that is, a system factor or repetitive-member factor) is justified in designing a header (HUD, 1999). The results showed that a repetitive-member factor is valid for headers constructed of only two members, as shown in table 5.3, and that additional system effects produce large increases in capacity when the header is overlaid by a double top plate, band joist, and sole plate, as shown in

example 5.5. Consequently, an overall system factor of 1.8 was found to be a simple, conservative design solution. That system factor is applicable to the adjusted bending stress value, F_b' , of the header member only. Although this example covers only a very specific condition, it exemplifies the magnitude of potential system effect in similar conditions. In this case, the system effect is associated with load sharing and partial composite action.

Headers are not required in non-load-bearing walls. Openings can be framed with single studs and a horizontal header block of the same size. It is common practice to use a double 2x4 or triple 2x4 header for larger openings in non-load-bearing walls. In the interest of added rigidity and fastening surface, however, some builders use additional jamb studs for openings in non-load-bearing walls, but such studs are not required.

5.5.4 Columns

Columns are vertical members placed where an axial force is applied parallel to the longitudinal axis. Columns may fail by either crushing or buckling. Longer columns have a higher tendency than shorter columns to fail as a result of buckling. The load at which the column buckles (Euler buckling load) is directly related to the ratio of the column's unsupported length to its depth (slenderness factor). The equations provided in section 5.3 are based on the NDS•3.7.1 provisions regarding the compression and stability of an axial compression member (that is, column) and thus account for the slenderness factor. Example 5.6 demonstrates column design.

Figure 5.6 illustrates three ways to construct columns using lumber. *Simple columns* are columns fabricated from a single piece of sawn lumber; *spaced columns* are fabricated from two or more individual members with their longitudinal axes parallel and separated with blocking at their ends and midpoint(s); *built-up columns* are solid columns fabricated from several individual members fastened together. Spaced columns as described in the NDS are not normally used in residential buildings and are not addressed here (refer to NDS•15.2 for the design of spaced columns).

Steel jack posts also are commonly used in residential construction; however, jack post manufacturers typically provide a rated capacity so that no design is required except the specification of the design load requirements and the selection of a suitable jack post that meets or exceeds the required loading. Typical 8-foot tall steel jack posts are made of pipe and have adjustable bases for floor leveling. The rated (design) capacity generally ranges from 10,000 to 20,000 pounds, depending on the steel pipe diameter and wall thickness.

Simple columns are fabricated from one piece of sawn lumber. In residential construction, simple columns such as a 4x4 are common. The equations in section 5.3 are used to design simple columns, as demonstrated in example 5.6.

Built-up columns are fabricated from several wood members fastened together with nails or bolts. They are commonly used in residential construction

because smaller members can be easily fastened together at the jobsite to form a larger column with adequate capacity.

The nails or bolts used to connect the separate members of a built-up column do not rigidly transfer shear loads; therefore, the bending load capacity of a built-up column is less than a single column of the same species, grade, and cross-sectional area when bending direction is perpendicular to the laminations (that is, all members bending in their individual weak-axis direction). The coefficient, K_f , accounts for the capacity reduction in bending load for nailed or bolted built-up columns. K_f applies, however, only to the weak-axis buckling or bending direction of the individual members and therefore should not be used to determine C_p for column buckling in the strong-axis direction of the individual members. (Refer to NDS•15.3 for nailing and bolting requirements for built-up columns.)

The preceding consideration is not an issue when the built-up column is sufficiently braced in the weak-axis direction (that is, embedded in a sheathed wall assembly). In this typical condition, the built-up column actually is stronger than a solid sawn member of equivalent size and grade because of the repetitive-member effect on bending capacity (see table 5.3). When the members in the built-up column are staggered or spliced, however, the column bending strength is reduced. Although the NDS•15.3 provisions apply only to built-up columns with all members extending the full height of the column, design methods for spliced columns are available (ASAE, 1997).

FIGURE 5.6 *Wood Column Types*

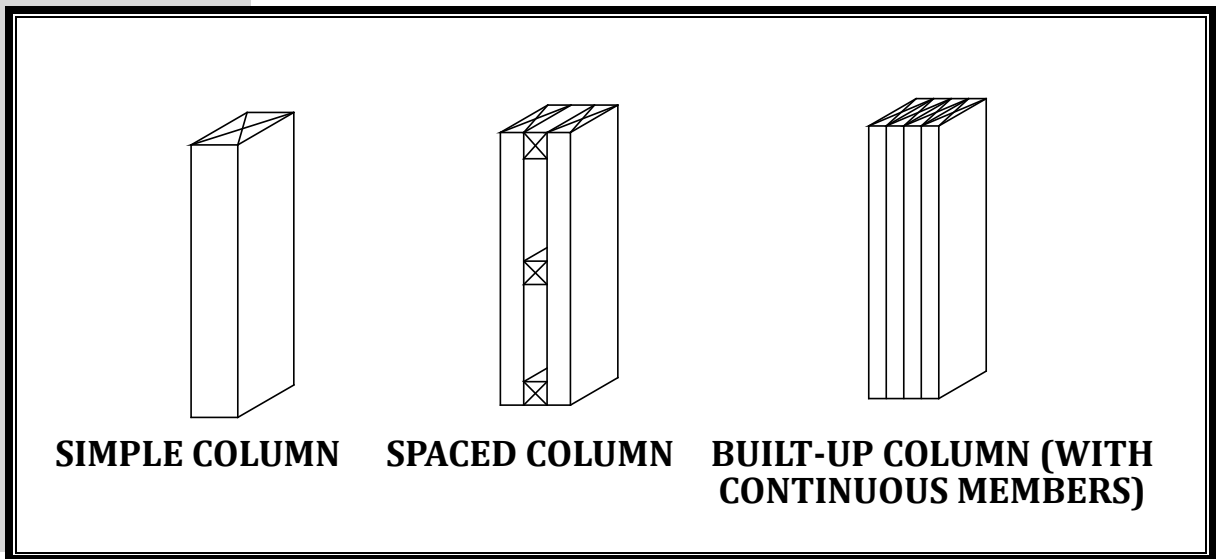

5.6 Roofs

The objectives of roof framing design are—

- To support building dead and snow loads and to resist wind and seismic forces.
- To resist roof construction and maintenance loads.
- To provide a thermal and weather barrier.
- To provide support for interior finishes.
- To provide attic space and access for electrical and mechanical equipment or storage.

5.6.1 General

A roof in residential construction typically is a sloped structural system that supports gravity and lateral loads and transfers the loads to the walls below. Generally, the four options for wood roof construction are—

- Roof trusses.
- Rafters and ceiling joists (with or without rafter or collar ties).
- Rafters with ridge beams (that is, cathedral ceilings).
- Timber framing.

By far the most common types of residential roof construction use light-frame trusses, rafters, or a mix of those materials, depending on roof layout. Figure 5.7 depicts conventional roof construction and roof framing elements. Rafters are repetitive framing members that support the roof sheathing and typically span from the exterior walls to a nonstructural ridge board. Rafter pairs may also be joined at the ridge with a gusset, thereby eliminating the need for a ridge board. Rafters may also be braced at or near mid-span using intermittent 2x vertical braces and a 2x runner crossing the bottom edges of the rafters. Ceiling joists are repetitive framing members that support ceiling and attic loads and transfer the loads to the walls and beams below. They are not typically designed to span between exterior walls and therefore require an intermediate bearing wall. Overhangs are framed extensions of the roof that protrude beyond the exterior wall of the home, typically by 1 to 2 feet. Overhangs protect walls and windows from direct sun and rain and therefore offer durability and energy efficiency benefits.

Ceiling joists typically are connected to rafter pairs to resist outward thrust generated by loading on the roof. Where ceiling joists or collar ties are eliminated to create a cathedral ceiling, a structural ridge beam must be used to support the roof at the ridge and to prevent outward thrust of the bearing walls. Ceiling joists and roof rafters are bending members that are designed similarly; therefore, this chapter groups them under one section.

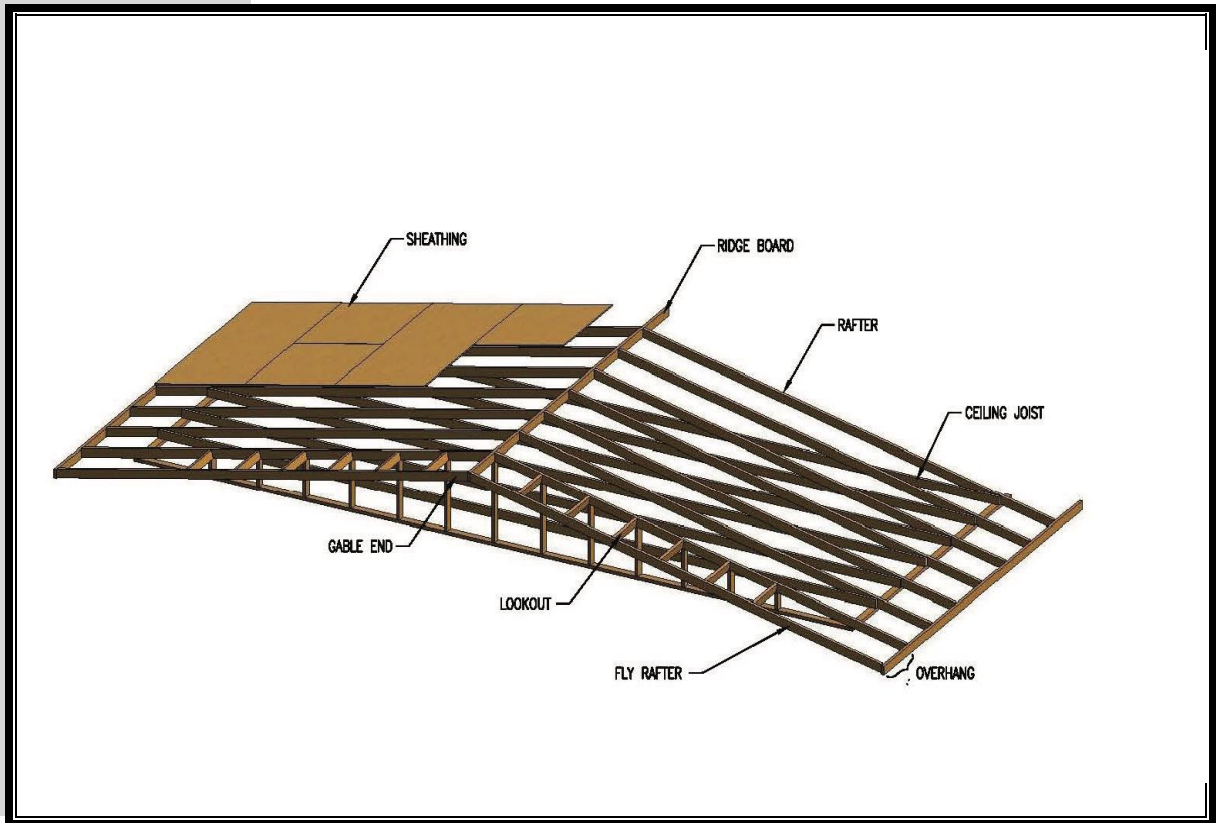
FIGURE 5.7***Structural Elements of a Conventional Roof System***

Roof trusses are pre-engineered components. They are fabricated from 2-inch thick dimension lumber connected with metal truss plates. They are generally more efficient than stick framing and usually are designed to span from exterior wall to exterior wall with no intermediate support. Complex portions of roof systems, however, often use rafter-framing techniques.

Roof sheathing is a thin structural element, usually plywood or OSB, which supports roof loads and distributes lateral and axial loads to the roof framing system. Roof sheathing also provides lateral support to the roof framing members and serves as a membrane or diaphragm to resist and distribute lateral building loads from wind or earthquakes (refer to chapter 6).

Roof systems are designed to withstand dead, live, snow, and wind uplift loads; in addition, they are designed to withstand lateral loads, such as wind and earthquake loads, transverse to the roof system. The design procedure discussed herein addresses dimension lumber roof systems designed according to the NDS. Where appropriate, the procedure incorporates modifications of the NDS. Section 5.3 summarizes the general design equations and design checks based on the NDS. Chapter 6 addresses the design of roofs with respect to lateral loads on the overall structure, and chapter 7 provides guidance on the design of connections.

When designing roof elements or components, the designer needs to consider the following load combinations from chapter 3 (table 3.1).

- $D + (L_r \text{ or } S \text{ or } R)$.
- $0.6 D + 0.6 W_u$.
- $D + 0.6 W$.

The following sections refer to the span of the member. As mentioned previously, the NDS defines span as the clear span of the member plus one-half the required bearing at each end of the member. For simplicity, the clear span between bearing points is used herein.

Finally, roofs exhibit system behavior that is in many respects similar to floor framing (see section 5.4); however, sloped roofs also exhibit unique system behavior. For example, the sheathing membrane or diaphragm on a sloped roof acts as a folded plate that helps resist gravity loads. The effect of the folded plate becomes more pronounced as roof pitch becomes steeper. Such a system effect usually is not considered in design but explains why light wood-framed roof systems may resist loads several times greater than their design capacity. Recent research on trussed roof assemblies with wood structural panel sheathing points to a system capacity increase factor of 1.1 to 1.5 relative to the design of an individual truss (Mtenga, 1998; Wolfe, 1996; Wolfe and LaBissoniere, 1991). Again, this system capacity increase factor is not recognized by either the NDS or the IRC (ICC, 2012), but it could potentially be used as an alternate method.

5.6.2 Conventional Roof Framing

This section addresses the design of conventional roof rafters, ceiling joists (collar ties), ridge beams, and hip and valley rafters. The design procedure for a rafter and ceiling joist system is similar to that for a truss except that the components and connections are site built. Standard pin-joint analysis is common practice to determine axial forces in the members and shear forces at their connections. The ceiling joists and rafters are then usually sized according to their individual applied bending loads, taking into account axial load effects on the members as appropriate. Frequently, intermediate rafter braces (rafter ties) that are similar to truss web members are also used when ceiling joists are not connected to or are not parallel with the rafters. Standard construction details and span tables for rafters and ceiling joists can be found in the IRC (ICC, 2012). These tables generally provide allowable horizontal rafter spans, disregarding any difference that roof slope may have on axial and bending loads experienced in the rafters. This approach generally is considered standard practice. Example 5.7 demonstrates two design approaches for a simply supported, sloped rafter, as illustrated in figure 5.8.

Structural ridge beams are designed to support roof rafters at the ridge when no ceiling joists or collar ties are used to resist the outward thrust of rafters. A repetitive-member factor, C_r , is applicable if the ridge beam is composed of two or more members (see table 5.4). Any additional roof system benefit, such as the folded plate action of the roof-sheathing diaphragm, goes ignored in its structural

contribution to the ridge beam, particularly for steep-sloped roofs. Example 5.8 demonstrates the design approach for ridge beams.

Roofs with hips and valleys are constructed with rafters framed into a hip or valley rafter as appropriate and, in practice, typically are one to two sizes larger than the rafters they support (for example, 2x8 or 2x10 hip for 2x6 rafters). While hip and valley rafters experience a unique tributary load pattern or area, they generally are designed much like ridge beams. The folded plate effect of the roof-sheathing diaphragm provides support to a hip or valley rafter in a manner similar to that discussed for ridge beams. Beneficial system effect goes ignored because of the lack of definitive technical guidance.

Many residential buildings are designed with cathedral ceilings. The framing method used for those high ceilings does not consider the ceiling as a brace at the top of the exterior walls because it is not in a plane that is perpendicular to the walls. A hinge forms in the framing at the cathedral ceiling–exterior wall connection on the gable end if the wall studs do not extend all the way to the roofline.

5.6.3 Roof Trusses

Roof trusses incorporate rafters (top chords) and ceiling joists (bottom chords) into a structural frame fabricated from 2-inch thick dimension lumber, usually 2x4 or 2x6. A combination of web members are positioned between the top and bottom chords, usually in triangular arrangements that form a rigid framework. Many different truss configurations are possible, including open trusses for attic rooms and cathedral or scissor trusses with sloped top and bottom chords. The wood truss members are connected by metal truss plates punched with barbs (that is, teeth) that are pressed into the truss members. Roof trusses are able to span the entire width of a home without interior support walls, allowing complete freedom in partitioning interior living space. The *Metal Plate Connected Wood Truss Handbook* contains span tables for typical truss designs (Callahan, 2004).

FIGURE 5.8

Design Methods and Assumptions for a Sloped Rafter

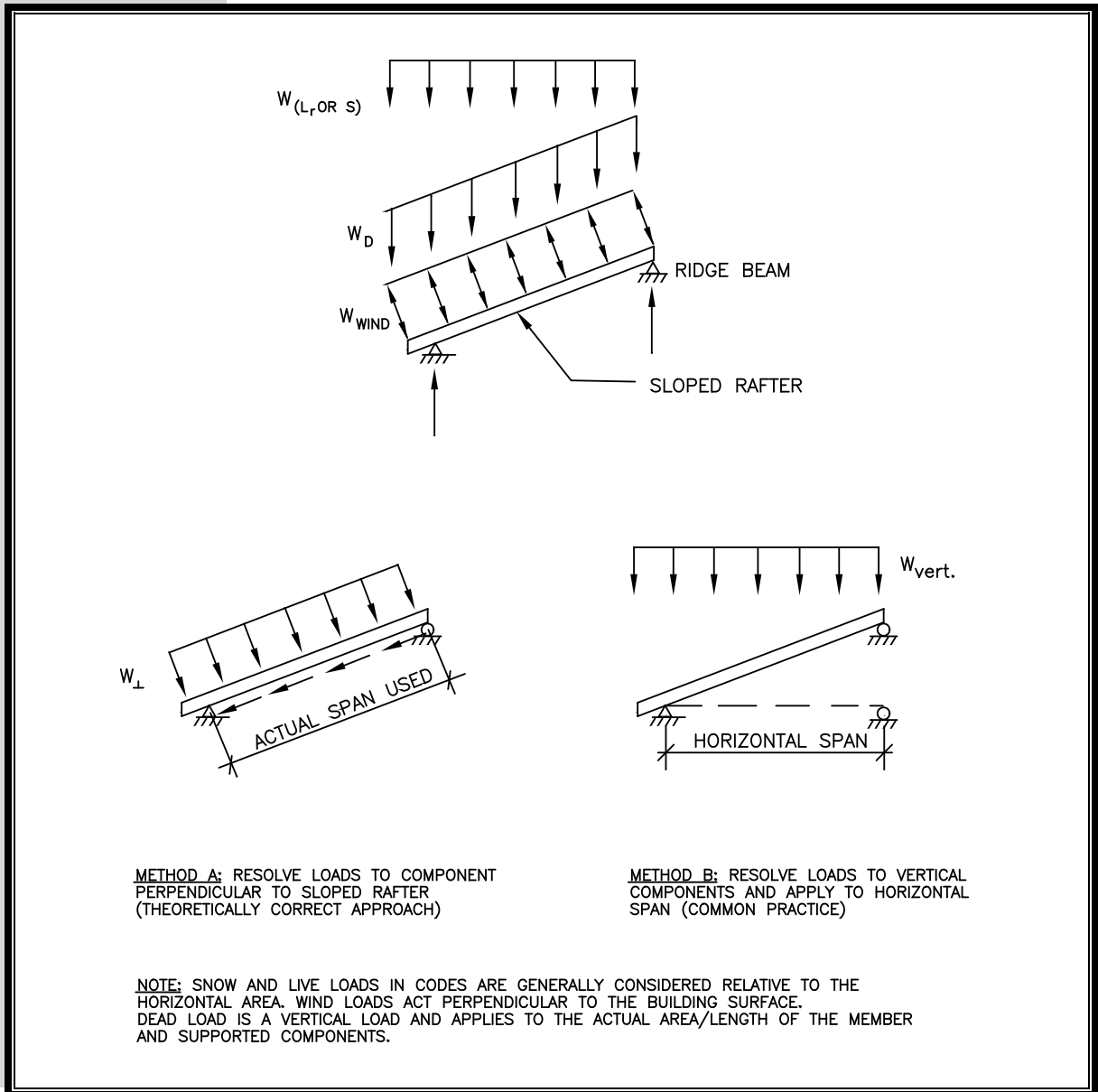

Roof truss manufacturers normally provide the required engineering design based on the loading conditions specified by the building designer or structural engineer of record (SER). The building designer is responsible for providing the following items to the truss manufacturer for design.

- Design loads.
- Truss profile.
- Support locations.
- Any special requirements.

The building designer must provide for permanent bracing of the truss system at locations designated by the truss designer to avoid invalidating any warranty on performance or design assumptions made by the truss designer. In general, such bracing may involve vertical cross-bracing, runners on the bottom chord, and the bracing of certain web members. In typical light-frame residential roof construction, properly attached roof sheathing provides adequate overall bracing of the roof truss system, and ceiling finishes typically provide lateral support to the bottom chord of the truss. The only exception is long web members that may experience buckling from excessive compressive loads. Section 5.6.6 addresses gable-end wall bracing separately as it pertains to the role of the roof system in supporting the walls against lateral loads, particularly those produced by wind. For more information and details on permanent bracing of trusses, refer to *Commentary for Permanent Bracing of Metal Plate Connected Wood Trusses* (WTCA, 1999). Temporary bracing during construction usually is the responsibility of the builder and is important for worker safety. Additional guidance on temporary bracing can be found in the *Metal Plate Connected Wood Truss Handbook*, pages 14-1 through 15-12 and appendix L (Callahan, 2004). *Standard Practice for Metal Plate Connected Wood Truss Design Responsibilities* (WTCA, 2008) contains additional guidance on roles and responsibilities.

The National Design Standard for Metal Plate Connected Wood Truss Construction (ANSI/TPI 1-07) and commentary governs the design of trusses. Available from the Truss Plate Institute (TPI, 2007a and TPI, 2007b), ANSI/TPI 1-07 includes the structural design procedure, requirements for truss installation and bracing, and standards for the manufacture of metal plate connectors. Truss plate manufacturers and truss fabricators generally have proprietary computerized design software based on ANSI/TPI 1-07, with modifications tailored to their particular truss-plate characteristics.

Cracking and separating of ceiling finishes may occur at joints between the walls and ceiling of roofs. In the unfavorable condition of high attic humidity, the top chord of a truss may expand while the lower roof members, typically buried under attic insulation, may not be similarly affected; thus, a truss may bow upward slightly. Other factors that commonly cause interior finish cracking but are not in any way associated with the roof truss include shrinkage of floor-framing members, foundation settlement, or heavy loading of a long-span floor, resulting in excessive deflection that may “pull” a partition wall downward from its attachment at the ceiling. To reduce the potential for cracking of ceiling finishes at partition wall intersections, 2x wood blocking should be installed at the top of partition wall plates as a backer for the ceiling finish material (that is, gypsum board). Ceiling drywall should not be fastened to the blocking or to the truss bottom chord within 16 to 24 inches of the partition. Proprietary clips are available for use in place of wood blocking, and resilient metal “hat” channels may also be used to attach the ceiling finish to the roof framing.

Trusses also are frequently used for floor construction to obtain long spans and to allow for the placement of mechanical systems (for example, ductwork and sanitary drains) in the floor cavity.

One efficient use of a roof truss is as a structural truss for the gable end above a garage opening to effectively eliminate the need for a garage door header. A truss often is used as a girder to support a large section of roof framing members including other roof trusses.

5.6.4 Roof Sheathing

Roof sheathing thickness typically is governed by the spacing of roof-framing members and live or snow loads. Sheathing is typically installed in accordance with prescriptive sheathing span rating tables published in a building code or made available by manufacturers. If the limit of the prescriptive tables is exceeded, the designer may need to perform calculations; however, such calculations are rarely necessary in residential construction. The process of selecting rated roof sheathing is similar to that for floor sheathing.

Nails are the primary fasteners used to attach sheathing to roof rafters. The most popular nail types are sinker, box, and common, of which all have different characteristics that affect structural properties (refer to chapter 7). The IRC requires common nails but also permits the use of staples. Proprietary power-driven fasteners (such as pneumatic nails and staples) are also used extensively. The building codes and APA tables recommend a fastener schedule for connecting sheathing to roof rafters. Generally, nails are placed at a minimum 6 inches on center at edges and 12 inches on center at intermediate supports. A 6-inch fastener spacing should also be used at the gable-end framing to help brace the gable end. Nail size is typically 8d, particularly because thinner power-driven nails are most commonly used. Roof sheathing is commonly 7/16- to 5/8-inch thick on residential roofs. In some cases, shear loads in the roof diaphragm resulting from lateral loads (that is, wind and earthquake) may require a more stringent fastening schedule (refer to chapter 6 for a discussion of fastening schedules for lateral load design). More importantly, large suction pressures on roof sheathing in high wind areas (see chapter 3) require a larger fastener, closer spacing, or fasteners with greater withdrawal capacity, such as ring shank nails. In hurricane-prone regions, codes commonly require an 8d ring shank nail with 6-inch, on-center spacing at all framing connections. At the gable-end truss or rafter, 4-inch fastener spacing is common.

While ring shank nails have greater withdrawal capacity, some types may also have reduced shear capacity and thus may require closer spacing to resist shear in the diaphragm. This subject is covered further in the International Code Council's *Standard on Residential Construction in High Wind Regions*, ICC 600 (ICC, 2008).

5.6.5 Roof Overhangs

Overhangs are projections of the roof system beyond the exterior wall line at either the eave or the rake (the sloped gable end). Overhangs protect walls from rain and shade windows from direct sun. When a roof is framed with wood trusses, an eave overhang typically is constructed by extending the top chord

beyond the exterior wall. When a roof is framed with rafters, the eave overhang is constructed by using rafters that extend beyond the exterior wall. The sloped rafters are cut with a “bird-mouth” to conform to the bearing support. Gable-end overhangs usually are framed by using a ladder panel that cantilevers over the gable end for either stick-framed or truss roofs (refer to figure 5.9 for illustrations of various overhang constructions).

A study completed in 1978 by the Southern Forest Experiment Station for the U.S. Department of Housing and Urban Development found that the protection afforded by overhangs extends the life of the wall below, particularly if the wall is constructed of wood materials (HUD, 1980). Entitled the *Prevention and Control of Decay in Homes*, the report correlates the climate index of a geographic area with a suggested overhang width and recommends highly conservative widths. *Moisture Resistant Homes* (HUD, 2006) also is a good source of information on the issue of moisture and decay in residential structures. As a reasonable guideline (given that in many cases no overhang is provided), protective overhang widths should be 12 to 24 inches in humid climates—more, if practicable. A rule of thumb is to provide a minimum of 12 inches of overhang width for each story of protected wall below; however, overhang width can significantly increase wind uplift loads on a roof, particularly in high-wind regions. The detailing of overhang framing connections (particularly at the rake overhang on a gable end) is a critical consideration in hurricane-prone regions. Often, standard metal clips or straps provide adequate connection. The need for special rake overhang design detailing depends on the length of the overhang, the design wind load condition, and the framing technique that supports the overhang (that is, 2x outriggers versus cantilevered roof sheathing supporting ladder overhang framing).

FIGURE 5.9

Typical Roof Overhang Construction

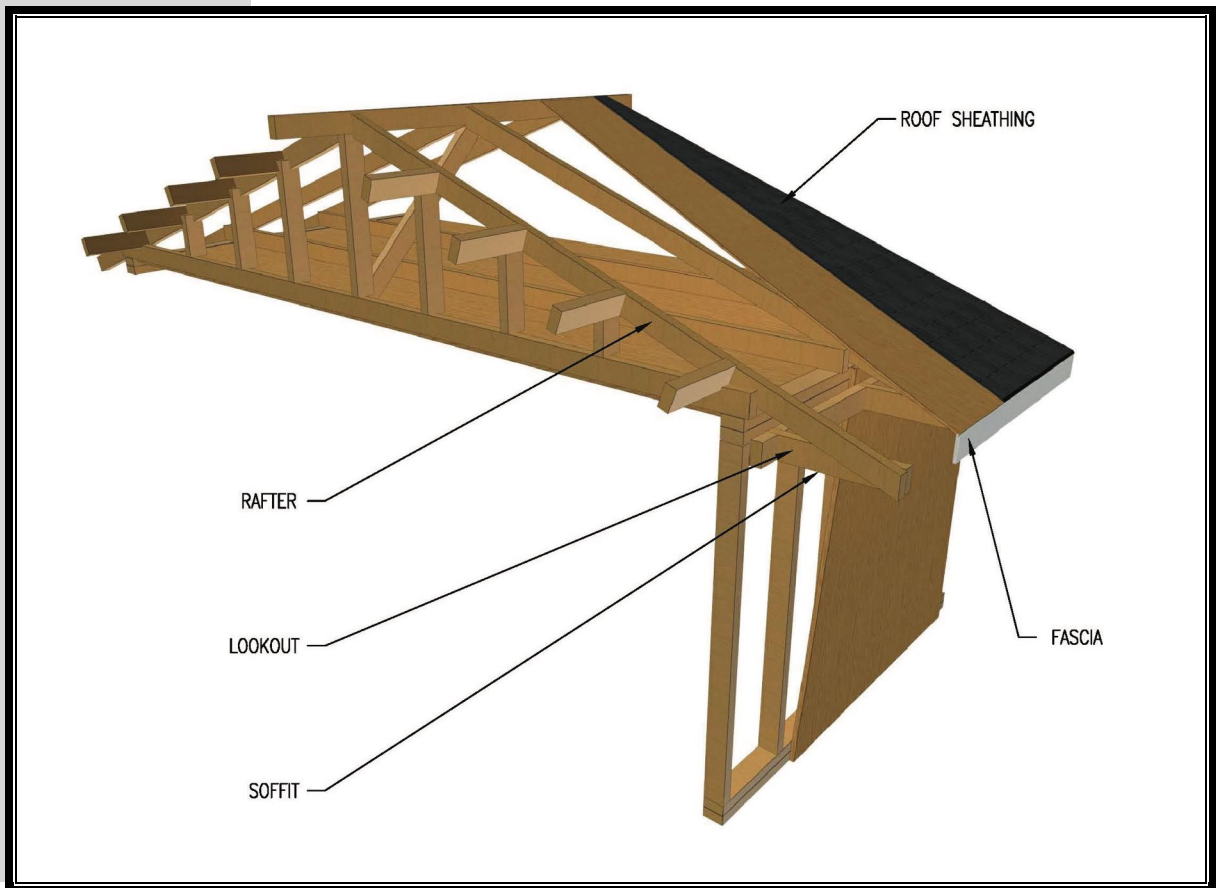

In high-wind areas, soffits should be solidly nailed to framing to prevent wind uplift of the soffit covering or to prevent the soffit covering from being pulled away from the framing. This will likely require solid blocking along the exterior wall and between roof rafters, or trusses that frame the overhang to provide nailing ledgers for the soffit covering. The 2012 IRC and ICC-600 also contain prescriptive details for constructing a blocking panel consisting of wall sheathing and 2x4 framing that can be substituted for solid blocking. Truss manufacturers also can provide a truss component in lieu of solid blocking or a prescriptive blocking panel.

5.6.6 Gable-End Wall Bracing

Roof framing provides lateral support to the top of the walls where trusses and rafters are attached to the wall top plate. Likewise, floor framing provides lateral support to the top and bottom of walls, including the top of foundation walls. At a gable end, when platform framing is used (see section 1.1), however, the top of the wall is not directly connected to roof-framing members; instead, it

is attached to the bottom of a gable-end truss, and lateral support at the top of the wall is provided by the ceiling diaphragm. In higher wind regions, the joint may become a “hinge” if it is not braced. Accordingly, common practice is to brace the top of the end wall (or bottom of the gable-end roof framing) with 2x4 or 2x6 framing members that slope upward to the roof diaphragm to attach to a blocking or a ridge “beam,” as shown in figure 5.10. Alternatively, braces may be laid flat on ceiling joists or truss bottom chords to transfer the load to a ceiling diaphragm. Given that braces must transfer inward and outward forces resulting from positive wind pressure or suction on the gable-end wall, the braces commonly are attached to the top of the gable-end wall with straps to transfer tension forces that may develop in hurricanes and other extreme wind conditions. The need for special detailing of gable-end wall braces depends on the height and area of the gable end (that is, tributary area) and the design wind load. The gable-end wall also can be braced using a wood structural panel attached to the gable-end framing and the ceiling framing members. Specific details for bracing gable-end walls in high-wind regions can be found in the *Wood Frame Construction Manual* (AWC, 2012c) or the ICC 600 Standard for Residential Construction in High Wind Regions (ICC, 2008).

As an alternative to the preceding strategy, the gable-end wall may be framed with continuous studs that extend to the roof sheathing at the gable end (that is, balloon framed). If the gable-end wall encloses a two-story room—such as a room with a cathedral ceiling, the studs must extend to the roof sheathing; otherwise, a hinge is created in the wall that could cause cracking of wall finishes (even in a moderate wind) and could easily precipitate failure of the wall in an extreme wind. Depending on wall height, stud size, stud spacing, and the design wind load condition, taller, full-height studs may have to be enlarged to meet deflection or bending capacity requirements. The designer must exercise judgment in this framing application with respect to deflection criteria.

Finally, as an alternative that avoids the gable-end wall-bracing problem, a hip roof may be used. The hip shape is inherently more resistant to wind damage in hurricane-prone wind environments and braces the end walls against lateral wind loads by directly attaching to rafters.

FIGURE 5.10 *Gable-End Wall Bracing*

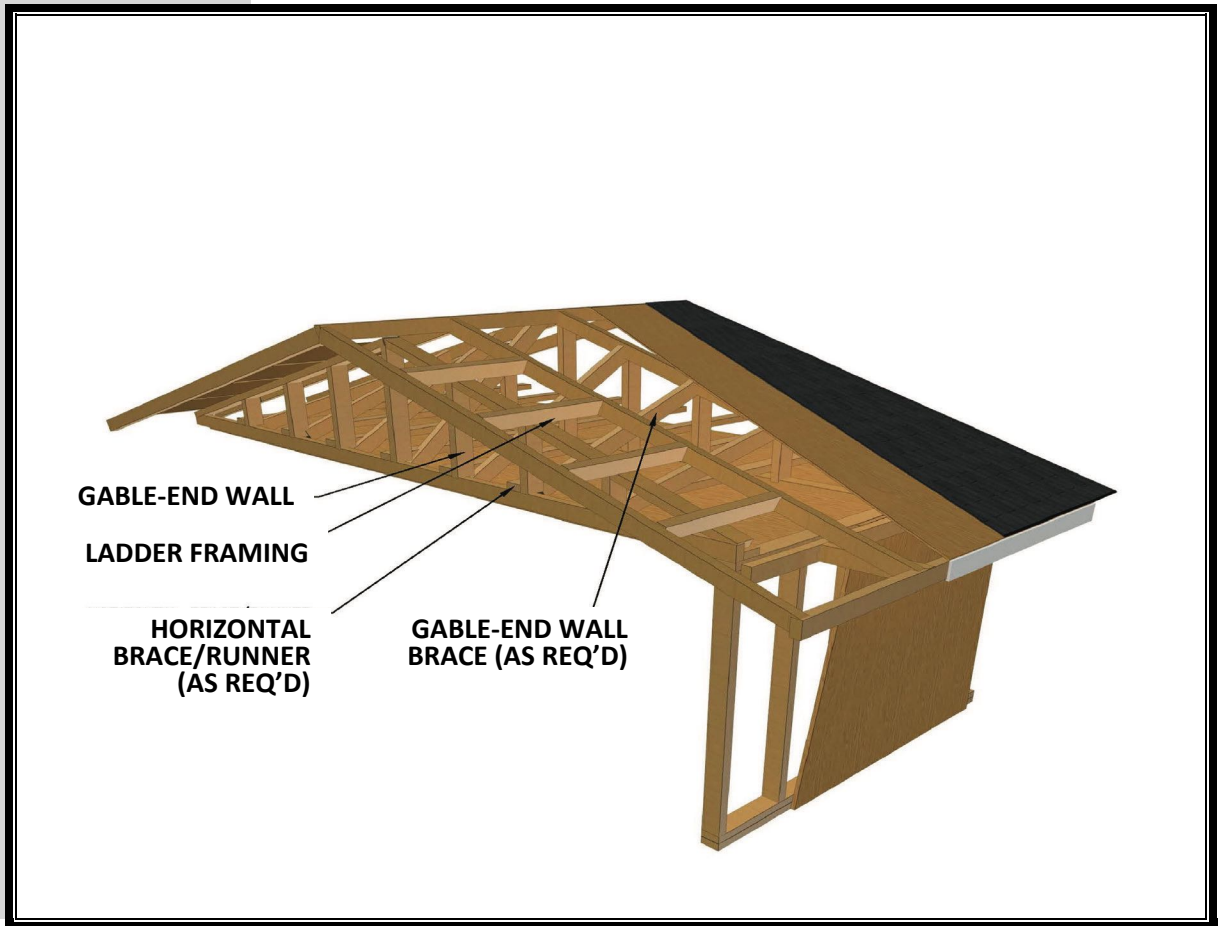

5.7 Design Examples

In this section, a number of design examples illustrate the design of various elements discussed in this chapter. The examples are intended to also provide practical advice; therefore, they are embellished with numerous notes and recommendations to improve the practicality and function of various possible design solutions. The examples also are intended to promote the designer's creativity in arriving at the best possible solution for a particular application.

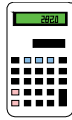

Given

Live load (L)	=	30 psf (bedroom area)
Dead load (D)	=	10 psf
Trial joist spacing	=	16 on center
Trial joist size	=	2x8
Trial joist species and grade	=	Hem-Fir, No. 1 (S-dry, 19% MC)

Find Maximum span for specified joist member.

Solution

- Determine tabulated design values by using NDS-S (tables 4A and 1B).

$F_b = 975$ psi	$I_{xx} = 47.63$ in ⁴
$F_v = 75$ psi	$S_{xx} = 13.14$ in ³
$F_{c\perp} = 405$ psi	$b = 1.5$ in
$E = 1,500,000$ psi	$d = 7.25$ in

- Lumber property adjustments and adjusted design values (section 5.2.4 and NDS•2.3)

$C_D = 1.0$	(section 5.2.4.1)
$C_r = 1.15$	(table 5.4)
$C_F = 1.2$	(NDS-S table 4A adjustment factors)
$C_H = 2.0$	(section 5.2.4.3)
$C_L = 1.0$	(NDS•3.3.3, continuous lateral support)
$C_b = 1.0$	(NDS•2.3.10)
$F_b' = F_b C_r C_F C_D C_L$	$= 975 (1.15)(1.2)(1.0)(1.0) = 1,345$ psi
$F_v' = F_v C_H C_D$	$= 75 (2)(1.0) = 150$ psi
$F_{c\perp}' = F_{c\perp} C_b$	$= 405 (1.0) = 405$ psi
$E' = E$	$= 1,500,000$ psi

- Calculate the applied load.

$$W = (\text{joist spacing})(D+L) = (16 \text{ in})(1 \text{ ft}/12 \text{ in})(40 \text{ psf}) = 53.3 \text{ plf}$$

- Determine maximum clear span based on bending capacity

$$M_{\max} = \frac{w\ell^2}{8} = \frac{(53.3 \text{ plf})(\ell^2)}{8} = 6.66 \ell^2$$

$$f_b = \frac{M}{S} = \frac{(6.66\ell^2)(12 \text{ in}/\text{ft})}{13.14 \text{ in}^3} = 6.08 \ell^2$$

$$f_b \leq F_b'$$

$$6.08 \ell^2 \leq 1,345 \text{ psi}$$

$$\ell^2 = 221$$

$$\ell = 14.9 \text{ ft} = 14 \text{ ft}-11 \text{ in (maximum clear span resulting from bending stress)}$$

5. Determine maximum clear span based on horizontal shear capacity

$$V_{\max} = \frac{w\ell}{2} = \frac{(53.3 \text{ plf})(\ell)}{2} = 26.7 \ell$$

$$f_v = \frac{3V}{2A} = \frac{3}{2} \left(\frac{26.7 \ell}{(1.5 \text{ in})(7.25 \text{ in})} \right) = 3.7 \ell$$

$$f_v \leq F_v'$$

$$3.7 \ell \leq 150 \text{ psi}$$

$$\ell = 40.5 \text{ ft} = 40 \text{ ft-6 in (maximum clear span resulting from horizontal shear stress)}$$

6. Determine maximum clear span based on bearing capacity

Bearing length = (3.5-in top plate width) - (1.5-in rim joist width) = 2 in

$$f_{c\perp} = \frac{\frac{1}{2}w\ell}{A_b} = \frac{\frac{1}{2}(53.3 \text{ plf})(\ell)}{(2 \text{ in})(1.5 \text{ in})} = 8.9 \ell$$

$$f_{c\perp} < F_{c\perp}'$$

$$8.9 \ell \leq 405 \text{ psi}$$

$$\ell = 45.5 \text{ ft} = 45 \text{ ft-6 in (maximum clear span resulting from bearing stress)}$$

7. Consider maximum clear span based on deflection criteria (section 5.3.2)

$$\Delta_{\max} = \frac{5w\ell^4}{384EI} = \frac{5(40 \text{ plf})^* (\ell)^4 (1,728 \text{ in}^3 / \text{ft}^3)}{384(1,500,000 \text{ psi})(47.63 \text{ in}^4)} = 1.26 \times 10^{-5} \ell^4$$

*applied live load of 30 psf only

$$\Delta_{\text{all}} = \frac{\ell}{360} (12 \text{ in/ft}) = 0.033 \ell$$

$$\Delta_{\max} \leq \Delta_{\text{all}}$$

$$1.26 \times 10^{-5} \ell^4 \leq 0.033 \ell$$

$$\ell^3 = 2,619$$

$$\ell = 13.8 \text{ ft} = 13 \text{ ft-10 in (recommended clear span limit resulting from deflection criteria)}$$

8. Consider floor vibration (section 5.3.2).

The serviceability deflection check was based on the design floor live load for bedroom areas of 30 psf. The vibration control recommended in section 5.3.2 is to use a 40 psf design floor live load with the $\ell/360$ deflection limit. Given that the span will not be greater than 15 feet, using the absolute deflection limit of 0.5 inch is not necessary.

$$w = (16 \text{ in})(1 \text{ ft}/12 \text{ in})(40 \text{ psf}) = 53.3 \text{ plf}$$

$$\Delta_{\text{all}} = \left(\frac{\ell}{360} \right) (12 \text{ in/ft}) = 0.033 \ell$$

$$\Delta_{\max} = \frac{5 w \ell^4}{384 EI} = \frac{5(53.3 \text{ plf})^* (\ell^4) (1,728 \text{ in}^3 / \text{ft}^3)}{384(1.5 \times 10^6 \text{ psi})(47.63 \text{ in}^4)} = 1.7 \times 10^{-5} \ell^4$$

*applied live load of 40 psf only

$$\Delta_{\max} \leq \Delta_{\text{all}}$$

$$1.7 \times 10^{-5} \ell^4 \leq 0.033 \ell$$

$$\ell^3 = 1,941$$

$$\ell = 12.5 \text{ ft} = 12 \text{ ft}-6 \text{ in (recommended clear span limit resulting from vibration)}$$

Conclusion The serviceability limit states used for deflection and floor vibration limit the maximum span. The deflection-limited span is 13 ft-10 in, and the vibration-limited span is 12 ft-6 in. Span selection based on deflection or vibration is an issue of designer judgment. The maximum span limited by the structural safety checks was 14 ft-11 in resulting from bending; therefore, the serviceability limit will provide a notable safety margin above that required. No. 2 grade lumber should be considered for economy because it will have only a small effect on the serviceability limits. Conversely, if floor stiffness is not an expected issue with the owner or occupant, the span may be increased beyond the serviceability limits if needed to “make it work.” Many serviceable homes have been built with 2x8 floor joists spanning as much as 15 feet; however, if occupants have a low tolerance for floor vibration, a lesser span should be considered.

For instructional reasons, shrinkage across the depth of the floor joist or floor system may be estimated as follows, based on the equations in section 5.3.2:

$$\begin{aligned} d_1 &= 7.25 \text{ in} & M_1 &= 19\% \text{ maximum (S-dry lumber)} \\ d_2 &= ? & M_2 &= 10\% \text{ (estimated equilibrium MC)} \end{aligned}$$

$$d_2 = d_1 \left(\frac{1 - \frac{a - 0.2M_2}{100}}{1 - \frac{a - 0.2M_1}{100}} \right) = 7.25 \text{ in} \left(\frac{1 - \frac{6.031 - 0.2(10)}{100}}{1 - \frac{6.031 - 0.2(19)}{100}} \right) = 7.1 \text{ in}$$

$$\text{Shrinkage} \cong 7.25 \text{ ft}-7.08 \text{ in} = 0.15 \text{ in (almost } 3/16 \text{ in)}$$

In a typical wood-framed house, shrinkage should not be a problem, provided that the shrinkage is uniform throughout the floor system. In multistory platform frame construction, the same amount of shrinkage across each floor can add up to become a problem, and mechanical systems and structural details should allow for such movement. Kiln-dried lumber may be specified to limit shrinkage and building movement after construction.

EXAMPLE 5.2
Simple Span Floor Joist Design (Optimum Lumber)

Given

Live load (L) = 40 psf
 Dead load (D) = 10 psf
 Clear span = 14 ft-2 in
 Joist size = 2x10

Find Optimum lumber species and grade

		Solution
	1.	Calculate the applied load. $W = (\text{joist spacing})(D+L) = (2 \text{ ft})(40 \text{ psf} + 10 \text{ psf}) = 100 \text{ plf}$
	2.	Determine bending stress $M_{\max} = \frac{w\ell^2}{8} = \frac{(100 \text{ plf})(14.17 \text{ ft}^2)}{8} = 2,510 \text{ ft-lb}$ $F_b = \frac{M}{S} = \frac{(2,510 \text{ ft-lb})(12 \text{ in / ft})}{21.39 \text{ in}^3} = 1,408 \text{ psi}$
	3.	Determine horizontal shear stress. $V_{\max} = \frac{w\ell}{2} = \frac{(100 \text{ plf})(14.17 \text{ ft})}{2} = 709 \text{ lb}$ $f_v = \frac{3V}{2A} = \frac{3(709 \text{ lb})}{2(1.5 \text{ in})(9.25 \text{ in})} = 77 \text{ psi}$
	4.	Determine bearing stress. $R_1 = R_2 = V_{\max} = 709 \text{ lb}$ $f_{c\perp} = \frac{R}{A_b} = \frac{709 \text{ lb}}{(2 \text{ in})(1.5 \text{ in})} = 236 \text{ psi}$ <p style="text-align: center;">=</p> Wall and roof loads, if any, are carried through rim/band joist.
	5.	Determine minimum modulus of elasticity resulting from selected deflection criteria. $\Delta_{\max} = \frac{5w\ell^4}{384EI} = \frac{5(80 \text{ plf}) * (14.17 \text{ ft})^4 (1,728 \text{ in}^3 / \text{ft}^3)}{384E (98.93 \text{ in}^4)}$ $= 733,540/E$ <p style="text-align: center;">*includes live load of 40 psf only</p> $\Delta_{\text{all}} \leq \frac{\ell}{360}$ $\Delta_{\max} \leq \Delta_{\text{all}}$ $\frac{733,540}{E} = \frac{(14.17 \text{ ft})(12 \text{ in / ft})}{360}$ $E_{\min} = 1.55 \times 10^6 \text{ psi}$

6. Determine minimum modulus of elasticity resulting from vibration.

The span required is not greater than 15 feet, and the $\ell/360$ deflection check uses a 40 psf floor live load; therefore, the deflection check is assumed to provide adequate vibration control.

7. Determine minimum required unadjusted properties by using NDS tabulated lumber data.

$$\begin{aligned} \text{Bending} \quad f_b &\leq F_b' \\ F_b' &= F_b C_t C_F C_D \\ F_{b\min} &= \frac{1,408 \text{ psi}}{(1.15)(1.1)(1.0)} = 1,113 \text{ psi} \end{aligned}$$

$$\begin{aligned} \text{Horizontal shear} \quad f_v &\leq F_v' \\ F_v' &= F_v C_H C_D \\ F_{v\min} &= \frac{f_v}{C_H C_D} = \frac{77 \text{ psi}}{(2)(1.0)} = 39 \text{ psi} \end{aligned}$$

$$\begin{aligned} \text{Bearing} \quad f_{c\perp} &\leq F_{c\perp}' \quad (\text{assume minimum 2-in bearing}) \\ F_{c\perp}' &= F_{c\perp} C_b \\ F_{c\perp\min} &= \frac{f_{c\perp}}{(1.0)} = 236 \text{ psi} \end{aligned}$$

Minimum unadjusted tabulated properties required

$$\begin{aligned} F_b &= 1,113 \text{ psi} & F_{c\perp} &= 236 \text{ psi} \\ F_v &= 39 \text{ psi} & E &= 1.55 \times 10^6 \text{ psi} \end{aligned}$$

8. Select optimum lumber grade considering local availability and price by using NDS-S table 4A or 4B data.

Minimum No. 2 grade lumber is recommended for floor joists because of factors related to lumber quality, such as potential warping and straightness, that may affect constructability and create call-backs.

Considering 2x10 Douglas-Fir-Larch, the grade below (No. 1 and better) was selected to meet the required properties.

$$\begin{aligned} F_b &= 1,200 \text{ psi} > 1,113 \text{ psi} && \text{OK} \\ F_v &= 95 \text{ psi} > 39 \text{ psi} && \text{OK} \\ F_{c\perp} &= 625 \text{ psi} > 236 \text{ psi} && \text{OK} \\ E &= 1.8 \times 10^6 \text{ psi} > 1.55 \times 10^6 \text{ psi} && \text{OK} \end{aligned}$$

Conclusion Many other species and grades should be considered, depending on local availability and cost. Also, the No. 1 and higher grades are generally considered “premium” lumber. A lower grade 2x12 should be considered or, perhaps, engineered wood I-joists.

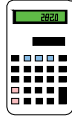

Given

Loads

Floor live load (L)	=	40 psf
Floor dead load (D)	=	10 psf
Required girder span (support column spacing)	=	14 ft
Joist span (both sides of girder)	=	12 ft
Species	=	Southern Pine, No. 1
Maximum girder depth	=	12

Find

Minimum number of 2x10 or 2x12 required for the built-up girder.

Solution

1. Calculate the design load.

$$W = (\text{Trib. floor joist span})(D + L) = (12 \text{ ft})(40 \text{ psf} + 10 \text{ psf}) = 600 \text{ plf}$$

2. Determine tabulated design values (Revised values effective 6/1/13)

$$\begin{array}{ll} F_b = 1000 \text{ psi} & F_{c\perp} = 565 \text{ psi} \\ F_v = 175 \text{ psi} & E = 1.6 \times 10^6 \text{ psi} \end{array}$$

3. Lumber property adjustments (section 5.2.4):

$$\begin{array}{ll} C_r = 1.2 \text{ (table 5.4)} & C_D = 1.0 \\ C_F = 1.0 & C_b = 1.0 \\ C_H = 2.0 & C_L = 1.0 \end{array}$$

(Compression flange laterally braced by connection of floor joists to top or side of girder)

$$\begin{array}{llll} F_b' & = & F_b C_D C_r C_F C_L & = 1,000 \text{ psi} (1.0)(1.2)(1)(1) = 1,200 \text{ psi} \\ F_v' & = & F_v C_D C_H & = 175 \text{ psi} (1.25)(2.0) = 438 \text{ psi} \\ F_{c\perp}' & = & F_{c\perp} C_b & = 565 \text{ psi} (1) = 565 \text{ psi} \\ E' & = & E & = 1.6 \times 10^6 \text{ psi} \end{array}$$

4. Determine number of members required resulting from bending.

$$M_{\max} = \frac{w\ell^2}{8} = \frac{(600 \text{ plf})(14 \text{ ft})^2}{8} = 14,700 \text{ ft-lb}$$

$$f_b = \frac{M}{S} = \frac{(14,700 \text{ ft-lb})(12 \text{ in/ft})}{S} = \frac{176,400}{S}$$

$$\begin{array}{ll} f_b & \leq F_b' \\ \frac{176,400}{S} & \leq 1,200 \text{ psi} \end{array}$$

$$S_x = 147 \text{ in}^3$$

Using table 1B in NDS-S

five 2x12 $S = 5 (31.64) = 158 > 147$ OK, but five pieces is too many

5. Determine number of members required resulting from horizontal shear

$$V_{\max} = \frac{w\ell}{2} = \frac{600 \text{ plf} (14 \text{ ft})}{2} = 4,200 \text{ lb}$$

$$f_v = \frac{3V}{2A} = \frac{3}{2} \left(\frac{4200}{A} \right) = \frac{6,300 \text{ lb}}{A}$$

$$f_v \leq F_v'$$

$$\frac{6,300 \text{ lb}}{A} \leq 438 \text{ psi}$$

$$A = 14 \text{ in}^2 \begin{array}{l} 1 \text{ 2x12} \\ 1 \text{ 2x10} \end{array} \quad \begin{array}{l} A = 16.9 > 14 \text{ OK} \\ A = 13.9 \approx 14 \text{ OK} \end{array}$$

6. Determine required bearing length using 4 2x12.

$$R_1 = R_2 = V_{\max} = 4,200 \text{ lb}$$

$$f_{c\perp} = \frac{R}{A_b} = \frac{4,200 \text{ lb}}{(6 \text{ in})(\ell_b)} = \frac{700}{\ell_b}$$

$$f_{c\perp} \leq F_{c\perp}'$$

$$\frac{700}{\ell_b} \leq 565 \text{ psi}$$

$$\ell_b = 1.24 \text{ in OK}$$

7. Determine member size resulting from deflection.

$$\Delta_{\max} = \frac{5w\ell^4}{384EI} = \frac{5(480 \text{ plf}) * (14 \text{ ft})^4 (1,728 \text{ in}^3 / \text{ft}^3)}{384 EI} = \frac{4.15 \times 10^8}{EI}$$

*includes 40 psf live load only

$$\Delta_{\text{all}} \leq \frac{\ell}{360} = \frac{14 \text{ ft} (12 \text{ in} / \text{ft})}{360} = 0.47 \text{ in}$$

$$\Delta_{\max} \leq \Delta_{\text{all}}$$

$$\frac{4.15 \times 10^8}{EI} = 0.47 \text{ in}$$

$$EI = 8.8 \times 10^8 = (1.6 \times 10^6)(I)$$

$$I = 550 \text{ in}^4 \text{ select four 2x12 (} I = 178 \text{ in}^4)$$

$$I = 712 \text{ in}^4 > 550 \text{ OK}$$

8. Check girder for floor system vibration control (see section 5.3.2).

$$\text{Girder span, } \ell_1 = 14 \text{ ft}$$

$$\text{Joist span, } \ell_2 = 12 \text{ ft}$$

$$\ell_{\text{TOTAL}} = 26 \text{ ft} > 20 \text{ ft}$$

Therefore, check girder using $\ell/480$ or $\ell/600$ $\ell/600$ to stiffen floor system.

Try $\ell/480$

$$\Delta_{\max} = \frac{4.15 \times 10^8}{EI} \text{ (as before)}$$

$$\Delta_{\text{all}} = \frac{\ell}{480} = \frac{14 \text{ ft} (12 \text{ in / ft})}{480} = 0.35 \text{ in}$$

$$\Delta_{\max} \leq \Delta_{\text{all}}$$

$$\frac{4.15 \times 10^8}{EI} = 0.35 \text{ in}$$

$$EI = 1.2 \times 10^9$$

$$I = \frac{1.2 \times 10^9}{1.6 \times 10^6} = 750 \text{ in}^4$$

Using table 1B in NDS, use

five 2x12 $I = 5 (178 \text{ in}^4) = 890 \text{ in}^4 > 750 \text{ in}^4$ OK

Conclusion The bending stress limits the floor girder design to five 2x12 (No. 1, Southern Yellow Pine). The use of five 2x12 also provides a “stiff” girder with respect to floor vibration (i.e., deflection limit of $\ell/480$). As a practical alternative, a steel “floor beam” (for example, W-shape) or an engineered wood beam may also be used, particularly if “clearance” is a concern.

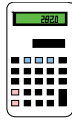
EXAMPLE 5.4**Exterior Bearing Wall Design**

Given	Stud size and spacing	=	2x4 at 24 in on center
	Wall height	=	8 ft
	Species and grade	=	Spruce-Pine-Fir, Stud Grade
	Exterior surface	=	7/16-in-thick OSB
	Interior surface	=	1/2-in-thick, gypsum wall board
	Wind load (100 mph, gust)	=	16 psf (see chapter 3, example 3.2)

Find Vertical load capacity of stud wall system for bending (wind) and axial compression (dead load) and for axial compression only (that is, dead, live, and snow loads); refer to chapter 3, table 3.1, for applicable load combinations.

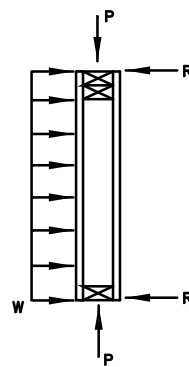

Wall Loading Diagram

Solution

- Determine tabulated design values for the stud by using the NDS-S (table A4).

$$\begin{array}{ll}
 F_b = 675 \text{ psi} & F_{c-L} = 425 \text{ psi} \\
 F_t = 350 \text{ psi} & F_c = 725 \text{ psi} \\
 F_v = 70 \text{ psi} & E = 1.2 \times 10^6 \text{ psi}
 \end{array}$$

- Determine lumber property adjustments (see section 5.2.4).

$$\begin{array}{l}
 C_D = 1.6 \text{ (wind load combination)} \\
 \quad = 1.25 \text{ (gravity/snow load combination)} \\
 C_r = 1.5 \text{ (sheathed wall assembly, table 5.4)} \\
 C_L = 1.0 \text{ (continuous lateral bracing)} \\
 C_F = 1.05 \text{ for } F_c \\
 \quad = 1.1 \text{ for } F_t \\
 \quad = 1.1 \text{ for } F_b
 \end{array}$$

- Calculate adjusted tensile capacity.

Not applicable to this design. Tension capacity is OK by inspection.

- Calculate adjusted bending capacity.

$$F_b' = F_b C_D C_L C_F C_r = (675)(1.6)(1.0)(1.1)(1.5) = 1,782 \text{ psi}$$

5. Calculate adjusted compressive capacity (NDS•3.7).

$$F_c^* = F_c C_D C_F = (725 \text{ psi})(1.6)(1.05) = 1,218 \text{ psi}$$

$$E' = E = 1.2 \times 10^6 \text{ psi}$$

$$K_{cE} = 0.3 \text{ visually graded lumber}$$

$$c = 0.8 \text{ sawn lumber}$$

$$F_{cE} = \frac{K_{cE} E'}{\left(\frac{l_e}{d}\right)^2} = \frac{0.3(1.2 \times 10^6 \text{ psi})}{\left[\frac{8 \text{ ft}(12 \text{ in/ft})}{3.5 \text{ in}}\right]^2} = 479 \text{ psi}$$

$$C_p = \frac{1 + \left(\frac{F_{cE}}{F_c^*}\right)}{2c} - \sqrt{\left[\frac{1 + \left(\frac{F_{cE}}{F_c^*}\right)}{2c}\right]^2 - \frac{F_{cE}/F_c^*}{c}} \quad (\text{column stability factor})$$

$$= \frac{1 + \left(\frac{479}{1,218}\right)}{2(0.8)} - \sqrt{\left[\frac{1 + \left(\frac{479}{1,218}\right)}{2(0.8)}\right]^2 - \frac{479/1,218}{0.8}} = 0.35$$

$$F_c' = F_c C_D C_F C_p = (725 \text{ psi})(1.6)(1.05)(0.35) = 426 \text{ psi}$$

Axial load only case

Calculations are same as above except use $C_D = 1.25$

$$F_c^* = 952 \text{ psi}$$

$$C_p = 0.44$$

$$F_c' = F_c C_D C_F C_p = 725 \text{ psi} (1.25)(1.05)(0.44) = 419 \text{ psi}$$

6. Calculate combined bending and axial compression capacity for wind and gravity load (dead load only) by using the combined stress interaction (CSI) equation (NDS•3.9.2).

$$f_b = \frac{M}{S} = \frac{\frac{1}{8} w l^2}{S}$$

$$= \frac{\frac{1}{8} (24 \text{ in})(16 \text{ psf}) \left[\frac{8 \text{ ft}(12 \text{ in/ft})}{12 \text{ in}}\right]^2 (1 \text{ ft/12 in})}{3.06 \text{ in}^3}$$

$$= 1,004 \text{ psi}$$

$$\left(\frac{f_c}{F_c'}\right)^2 + \frac{f_b}{F_b' \left[1 - \frac{f_c}{F_{cEI}}\right]} \leq 1.0 \quad (\text{CSI equation for bending in strong axis of stud}$$

only)

$$\left(\frac{f_c}{426}\right)^2 + \frac{1,004}{1,782\left(1 - \frac{f_c}{479}\right)} = 1.0 \quad (\text{solve CSI equation for } f_c)$$

$$f_{c, \max} = 163 \text{ psi/stud}$$

$$P = f_c A = (163 \text{ psi/stud})(1.5 \text{ in})(3.5 \text{ in}) = 856 \text{ lb/stud}$$

$$w = (856 \text{ lb/stud})\left(\frac{1 \text{ stud}}{2 \text{ ft}}\right) = 428 \text{ plf} \quad (\text{uniform dead load at top of wall})$$

Therefore, the maximum axial (dead) load capacity is 428 plf with the wind load case (that is, D+W).

7. Determine maximum axial gravity load without bending load.

This analysis applies to the D + L + 0.3(S or L_r) and D + (S or L_r) + 0.3L load combinations (see table 3.1, chapter 3).

Using F_c' determined in step 5 (axial load only case), determine the stud capacity acting as a column with continuous lateral support in the weak-axis buckling direction.

$$F_c \leq F_c'$$

$$\frac{P}{A} \leq 419 \text{ psi}$$

$$P_{\max} = (419 \text{ psi})(1.5 \text{ in})(3.5 \text{ in}) = 2,200 \text{ lbs/stud}$$

Maximum axial load capacity (without simultaneous bending load) is 2,200 lbs/stud or 1,100 lbs/lf of wall.

8. Check bearing capacity of wall plate.

Not a capacity limit state (F_{c⊥} is based on deformation limit state, not actual bearing capacity). OK by inspection.

Conclusion The axial and bending load capacity of the example wall is ample for most residential design conditions; thus, in most cases, using the prescriptive stud tables found in residential building codes may save time. Only in very tall walls (that is, greater than 10 feet) or more heavily loaded walls than typical will a special analysis as shown here be necessary, even in higher wind conditions. The controlling factor will likely be a serviceability limit state (that is, wall deflection) rather than strength, as shown in several of the floor design examples. In such cases, the wall system deflection adjustment factors of table 5.6 should be considered.

Note:

The axial compression capacity determined in this example is conservative because the actual EI (the product of the modulus of elasticity and the moment of inertia) of the wall system is not considered in the determination of C_p for stability. No method is currently available to include system effects in the analysis of C_p; however, a K_e factor of 0.8 may be used as a reasonable assumption to determine the effective buckling length, ℓ_e, which is then used to determine C_p (see NDS•3.7.1).

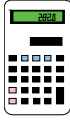

Given

Two-story house

Required header span = 6.3 ft (rough opening)

Species and grade = Spruce-Pine-Fir (south), No. 2 Grade

Loads on first-story header

$$w_{\text{floor}} = 600 \text{ plf (includes floor dead and live loads)}$$

$$w_{\text{wall}} = 360 \text{ plf (includes dead, live, and snow loads supported by wall above header)*}$$

$$w_{\text{total}} = 960 \text{ plf (includes dead, live, and snow loads)*}$$

*Combined loads are determined in accordance with table 3.1 of chapter 3.

Find

Determine header size (2x8 or 2x10) by considering system effect of all horizontal members spanning the opening.

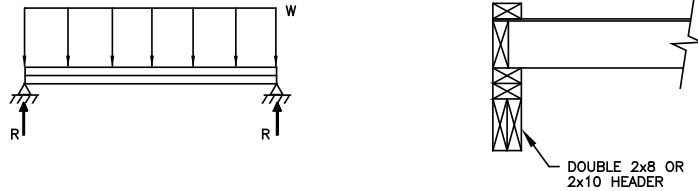

Header System

Solution

- Determine tabulated design values by using the NDS-S (table 4A).

$$\begin{aligned} F_b &= 775 \text{ psi} \\ F_v &= 70 \text{ psi} \\ F_{c\perp} &= 335 \text{ psi} \\ E &= 1.1 \times 10^6 \text{ psi} \end{aligned}$$

- Determine lumber property adjustments (section 5.2.4).

$$\begin{aligned} C_r &= 1.3 \text{ (2x10 double header per table 5.8)} \\ &= 1.2 \text{ (2x8 double header per table 5.4)} \\ C_D &= 1.25 \text{ (snow load)} \\ C_F &= 1.1 \text{ (2x10)} \\ &= 1.2 \text{ (2x8)} \\ C_H &= 2.0 \\ C_b &= 1.0 \\ C_L &= 1.0 \text{ laterally supported} \\ F_b' &= F_b C_D C_r C_F C_L = (775 \text{ psi})(1.25)(1.3)(1.1)(1.0) = 1,385 \text{ psi [2x10]} \\ &= (775 \text{ psi})(1.25)(1.2)(1.1)(1.0) = 1,279 \text{ psi [2x8]} \\ F_v' &= F_v C_D C_H = (70 \text{ psi})(1.25)(2) = 175 \text{ psi} \\ F_{c\perp}' &= F_{c\perp} C_b = (335 \text{ psi})(1) = 335 \text{ psi} \\ E' &= E = 1.1 \times 10^6 \text{ psi} \end{aligned}$$

With double top plate, F_b can be increased by 5 percent (table 5.8)

$$F_b' = F_b (1.05) = 1,385 \text{ psi} (1.05) = 1,454 \text{ psi} [2 \times 10]$$

$$F_b' = F_b (1.05) = 1,279 \text{ psi} (1.05) = 1,343 \text{ psi} [2 \times 8]$$

3. Determine header size resulting from bending for floor load only.

$$M_{\max} = \frac{w\ell^2}{8} = \frac{(600 \text{ plf})(6.5 \text{ ft})^2}{8} = 3,169 \text{ ft-lb}$$

$$f_b = \frac{M_{\max}}{S} \leq F_b'$$

$$1,454 \text{ psi} = \frac{3,169 \text{ ft-lb} (12 \text{ in / ft})}{S}$$

$$S = 26.2 \text{ in}^3$$

$$S \text{ for two } 2 \times 10 = 2(21.39 \text{ in}^3) = 42.78 \text{ in}^3 > 26.2 \text{ in}^3 \text{ OK}$$

Try two 2x8

$$1,343 \text{ psi} = \frac{3,169 \text{ ft-lb} (12 \text{ in / ft})}{S}$$

$$S = 28.3 \text{ in}^3$$

$$S \text{ for two } 2 \times 8 = 2(13.14) = 26.3 \text{ in}^3 < 28.3 \text{ in}^3$$

(close, but no good)

4. Determine member size resulting from bending for combined floor and supported wall loads by using the 1.8 system factor from table 5.8 but not explicitly calculating the load sharing with the band joist above.

$$F_b' = F_b (C_D)(C_r)(C_F)(C_L) = 775 \text{ psi}$$

$$(1.25)(1.8)(1.1)(1.0) = 1,918 \text{ psi}$$

$$M_{\max} = \frac{w\ell^2}{8} = \frac{(360 \text{ plf} + 600 \text{ plf})(6.5 \text{ ft})^2}{8} = 5,070 \text{ ft-lb}$$

$$f_b = \frac{M}{S} \leq F_b'$$

$$1,918 \text{ psi} = \frac{5,070 \text{ ft-lb} (12 \text{ in / ft})}{S}$$

$$S = 31.7 \text{ in}^3$$

$$S \text{ for two } 2 \times 10 = 42.78 \text{ in}^3 > 31.7 \text{ in}^3 \text{ OK}$$

5. Check horizontal shear.

$$V_{\max} = \frac{w\ell}{2} = \frac{(600 \text{ plf})(6.5)}{2} = 1,950 \text{ lb}$$

$$f_v = \frac{3V}{2A} = \frac{3(1,950 \text{ lb})}{2(2)(1.5 \text{ in})(9.25 \text{ in})} = 106 \text{ psi}$$

$$f_v \leq F_v'$$

$$106 \text{ psi} < 175 \text{ psi} \text{ OK}$$

6. Check for adequate bearing.

$$\begin{aligned}
R_1 = R_2 = V_{\max} &= 1,950 \text{ lb} \\
f_{c\perp} = \frac{R}{A_b} &= \frac{1,950 \text{ lb}}{(2)(1.5 \text{ in})(\ell_b)} = \frac{650}{\ell_b} \\
f_{c\perp} \leq F_{c\perp}' \\
\frac{650}{\ell_b} &= 335 \\
\ell_b &= 1.9 \text{ in} \\
&\text{OK for bearing, use two 2x4 jack studs } (\ell_b = 3 \text{ in})
\end{aligned}$$

7. Check deflection.

$$\begin{aligned}
\Delta_{\max} &= \frac{5w\ell^4}{384EI} = \frac{5(600 \text{ plf})(6.5 \text{ ft})^4 (1,728 \text{ in}^3 / \text{ft}^3)}{384(1.1 \times 10^6 \text{ psi})[(98.9 \text{ in}^4)(2)]} = 0.11 \text{ in} \\
\Delta_{\text{all}} &= L/240 = \frac{(6.5 \text{ ft})(12 \text{ in} / \text{ft})}{240} = 0.325 \text{ in} \\
\Delta_{\max} &< \Delta_{\text{all}}
\end{aligned}$$

Conclusion Using a system-based header design approach, a two-2x10 header of No. 2 Spruce-Pine-Fir is adequate for the 6 ft-3 in span opening. The loading condition is common to the first story of a typical two-story residential building. Using a stronger species or grade of lumber would allow the use of a two-2x8 header. Depending on the application and potential savings, using the header tables found in a typical residential building code may be more cost effective. For cost-effective ideas and concepts that allow for reduced header loads and sizes, refer to *Cost Effective Home Building: A Design and Construction Handbook* (NAHBRC, 1994). The document also contains convenient header span tables. For headers that are not part of a floor-band joist system, the design approach of this example is still relevant and similar to that used for floor girders. The 1.8 system factor used here would not apply, however, and the double top plate factor would apply only as appropriate.

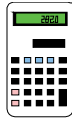

Given Basement column supporting a floor girder
 Spruce-Pine-Fir, No. 2 Grade
 Axial design load is 4,800 lbs (D + L)
 Column height is 7.3 ft (unsupported)

Find Adequacy of a 4x4 solid column

Solution

1. Determine tabulated design values by using the NDS-S (table 4A).

$$F_c = 1,150 \text{ psi}$$

$$E = 1.4 \times 10^6 \text{ psi}$$

2. Lumber property adjustments (section 5.2.4):

$$C_D = 1.0$$

$$C_F = 1.15 \text{ for } F_c$$

3. Calculate adjusted compressive capacity (NDS•3.7).

Trial 4x4

$$F_c^* = F_c C_D C_F = 1,150 \text{ psi} (1.0)(1.15) = 1,323 \text{ psi}$$

$$E' = E = 1.4 \times 10^6 \text{ psi}$$

$$K_{cE} = 0.3 \text{ for visually graded}$$

$$c = 0.8 \text{ for sawn lumber}$$

$$F_{cE} = \frac{K_{cE} E'}{\left(\frac{l_e}{d}\right)^2} = \frac{0.3 (1.4 \times 10^6 \text{ psi})}{\left(\frac{7.3 \text{ ft} (12 \text{ in / ft})}{3.5 \text{ in}}\right)^2} = 670 \text{ psi}$$

$$C_p = \frac{1 + \left(\frac{F_{cE}}{F_c^*}\right)}{2c} - \sqrt{\left[\frac{1 + \left(\frac{F_{cE}}{F_c^*}\right)}{2c}\right]^2 - \frac{F_{cE}}{F_c^*}}$$

$$= \frac{1 + \left(\frac{670}{1,323}\right)}{2(0.8)} - \sqrt{\left[\frac{1 + \left(\frac{670}{1,323}\right)}{2(0.8)}\right]^2 - \frac{670}{1,323}} = 0.44$$

$$F_c' = F_c C_D C_F C_p = (1,150 \text{ psi})(1.0)(1.15)(0.44) = 582 \text{ psi}$$

$$P_{all} = F_c' A = (582 \text{ psi})(3.5 \text{ in})(3.5 \text{ in}) = 7,129 \text{ lb} > 4,800 \text{ lb}$$

OK

Conclusion A 4x4 column is adequate for the 4,800-pound axial design load and the stated height and support conditions; in fact, greater column spacing could be used. Note that the analysis was performed with a solid sawn column of rectangular dimension. If a nonrectangular column is used, buckling must be analyzed in the weak-axis direction in consideration of the distance between lateral supports, if

any, in that direction. If a built-up column is used, it is NOT treated the same way as a solid column. Even if the dimensions are nearly the same, the built-up column is more susceptible to buckling resulting from slippage between adjacent members as flexure occurs in response to buckling (only if unbraced in the weak-axis direction of the built-up members). Slippage depends on how well the built-up members are fastened together, which is accounted for by the use of an additional adjustment (reduction) factor applied to the C_p equation (see section 5.5.5 and NDS•15.3).

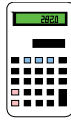
**Given**

Two-story home
 Rafter spacing 16 in on center
 Rafter horizontal span is 12 ft (actual sloped span is 14.4 ft)
 8:12 roof slope
 Design loads (see chapter 3):
 Dead load = 10 psf
 Roof snow load = 20 psf (20 psf ground snow)
 Wind load (90 mph, gust) = 12.7 psf (outward, uplift)
 = 7.4 psf (inward)
 Roof live load = 10 psf

Find

Minimum rafter size using No. 2 Douglas-Fir-Larch (refer to figure 5.7 for load diagram).

Solution

1. Evaluate load combinations applicable to rafter design (see chapter 3, table 3.1).

The load combinations to consider and initial assessment based on the magnitude of the given design loads follows—

$D + (L_r \text{ or } S)$ Controls rafter design in inward-bending direction (compression side of rafter laterally supported); L_r can be ignored because the snow load magnitude is greater.

$0.6D + W_u$ May control rafter design in outward-bending direction because the compression side now has no lateral bracing unless specified; also important to rafter connections at the bearing wall and ridge beam.

$D + W$ Not controlling by inspection; gravity load $D + S$ controls in the inward-bending direction.

2. Determine relevant lumber property values (NDS-S, table 4A).

$$\begin{aligned} F_b &= 900 \text{ psi} \\ F_v &= 95 \text{ psi} \\ E &= 1.6 \times 10^6 \text{ psi} \end{aligned}$$

3. Determine relevant adjustments to property values, assuming a 2x8 will be used (section 5.2.4).

$$\begin{aligned} C_D &= 1.6 \text{ (wind load combinations)} \\ &= 1.25 \text{ (snow load combination)} \\ C_r &= 1.15 \text{ (2x8, 24 inches on center)} \\ C_H &= 2.0 \\ C_F &= 1.2 \text{ (2x8)} \\ C_L &= 1.0 \text{ (inward bending, } D + S, \text{ laterally braced on compression edge)} \\ &= 0.32 \text{ (outward bending, } 0.6 D + W, \text{ laterally unbraced on compression edge)}^* \end{aligned}$$

*Determined in accordance with NDS•3.3.3

$$\begin{aligned}
\ell_e &= 1.63 \ell_u + 3d \\
&= 1.63 (14.4 \text{ ft}) + 3 (7.25 \text{ in})(1 \text{ in}/12\text{ft}) \\
&= 25.3 \text{ ft} \\
R_B &= \sqrt{\frac{\ell_e d}{b^2}} = \sqrt{\frac{(25.3 \text{ ft})(12 \text{ in} / \text{ft})(7.25 \text{ in})}{(1.5 \text{ in})^2}} \\
&= 31 < 50 \text{ (OK)} \\
K_{bE} &= 0.439 \text{ (visually graded lumber)} \\
F_{bE} &= \frac{K_{bE} E'}{R_B^2} = \frac{0.439 (1.6 \times 10^6 \text{ psi})}{(31)^2} = 730 \text{ psi} \\
F_b^* &= F_b C_D C_r C_F \\
&= 900 \text{ psi} (1.6)(1.15)(1.2) = 1,987 \text{ psi} \\
C_L &= \frac{1 + (F_{bE} / F_b^*)}{1.9} - \sqrt{\left[\frac{1 + (F_{bE} / F_b^*)}{1.9} \right]^2 - \frac{F_{bE} / F_b^*}{0.95}} \\
C_L &= 0.36 \quad (2 \times 8)
\end{aligned}$$

4. Determine rafter transverse bending load, shear, and moment for the wind uplift load case (using method A of figure 5.8).

The wind load acts transverse (that is, perpendicular) to the rafter; however, the snow load acts in the direction of gravity and must be resolved to its transverse component. Generally, the axial component of the gravity load along the rafter (which varies, depending on end connectivity) is ignored and has negligible impact considering the roof system effects that also are ignored. The limited overhang length will have a negligible impact on the design of the rafter; thus, the rafter can be reasonably analyzed as a sloped, simply supported bending member. In analyzing wind uplift connection forces at the outside bearing of the rafter, the designer should consider the additional uplift created by the small overhang, although for the stated condition it would amount only to about 20 pounds additional uplift load.

The net uniform uplift load perpendicular to the rafter is determined as follows:

$$\begin{aligned}
W_{D, \text{ transverse}} &= w_D (\cos \theta) \\
&= (10 \text{ psf})(1.33 \text{ ft})(\cos 33.7^\circ) \\
&= 11 \text{ plf} \\
W_{w, \text{ transverse}} &= (12.7 \text{ psf})(1.33 \text{ ft}) = 17 \text{ plf (uplift)} \\
W_{\text{total, transverse}} &= 17 \text{ plf} - 11 \text{ plf} = 6 \text{ plf (net uplift)} \\
\text{Shear, } V_{\text{max}} &= \frac{w\ell}{2} = \frac{(6 \text{ plf})(14.4 \text{ ft})}{2} = 44 \text{ lbs} \\
\text{Moment, } M_{\text{max}} &= 1/8 w\ell^2 \\
&= 1/8 (6 \text{ plf})(14.4 \text{ ft})^2 = 156 \text{ ft-lb}
\end{aligned}$$

5. Determine bending load, shear, and moment for the gravity load case (D + S) using method B of figure 5.8 (horizontal span).

$$\begin{aligned}
w_D &= (10 \text{ psf})(14.4 \text{ ft})(1.33 \text{ ft})/12 \text{ ft-horizontal} = 16 \text{ plf} \\
w_S &= (20 \text{ psf})(12 \text{ ft})(1.33 \text{ ft})/12 \text{ ft-horizontal} = 27 \text{ plf} \\
w_{\text{total}} &= 43 \text{ plf} \\
w_{\text{total}} &= (43 \text{ plf})(\cos 33.7^\circ) = 36 \text{ plf}
\end{aligned}$$

$$\text{Shear, } V_{\max} = \frac{(36 \text{ plf})(12 \text{ ft})}{2} = 216 \text{ lb}$$

$$\text{Moment, } M_{\max} = \frac{(36 \text{ plf})(12 \text{ ft})^2}{8} = 648 \text{ ft-lb}$$

6. Check bending stress for both loading cases and bending conditions.

Outward Bending ($0.6D + W_u$)

$$f_b = \frac{M}{S}$$

$$= \frac{156 \text{ ft-lb}}{13.14 \text{ in}^3} (12 \text{ in/ft}) = 142 \text{ psi}$$

$$F_b' = F_b C_D C_r C_F C_L$$

$$= 900 \text{ psi} (1.6)(1.15)(1.2)(0.36) = 715 \text{ psi}$$

$$f_b \ll F_b' \quad \text{OK, 2x8 works, and lateral bracing of bottom compression edge is not required.}$$

Inward Bending ($D + S$)

$$f_b = \frac{M}{S}$$

$$= \frac{648 \text{ ft-lb}}{13.14 \text{ in}^3} (12 \text{ in/ft}) = 591 \text{ psi}$$

$$F_b' = F_b C_D C_r C_F C_L$$

$$= 900 \text{ psi} (1.25)(1.15)(1.2)(1.0) = 1,553 \text{ psi}$$

$$f_b \ll F_b' \quad \text{OK}$$

7. Check horizontal shear.

$$V_{\max} = 216 \text{ lb} \quad (\text{see step 5})$$

$$f_v = \frac{3V}{2A} = \frac{3(216 \text{ lb})}{2(1.5 \text{ in})(7.25 \text{ in})} = 30 \text{ psi}$$

$$F_v' = F_v C_D C_H = 95 \text{ psi} (1.25)(2.0) = 238 \text{ psi}$$

$$f_v \ll F_v' \quad \text{OK}$$

8. Check bearing.

OK by inspection.

9. Check deflection criteria for gravity load condition (section 5.2.2).

$$\Delta_{\text{all}} = \frac{\ell}{180} = \frac{(14.4 \text{ ft})(12 \text{ in/ft})}{180} = 1.0 \text{ in}$$

$$\Delta_{\text{max}} = \frac{5w\ell^4}{384EI} = \frac{5(36 \text{ plf})(14.4 \text{ ft})^4}{384(1.6 \times 10^6 \text{ psi})(47.6 \text{ in}^4)} \quad (1,728 \text{ in}^3/\text{ft}^3)$$

$$= 0.4 \text{ in}$$

$$\Delta_{\text{max}} \ll \Delta_{\text{all}} \quad \text{OK, usually not a mandatory roof check}$$

Conclusion A 2x8, No. 2 Douglas-Fir-Larch rafter spaced at 16 inches on center was shown to have ample capacity and stiffness for the given design conditions. In fact, using

19.2-inch on center spacing (that is, five joists every 8 feet) would also work and be a more efficient use of lumber. A 2x6 could also possibly result in a reasonable rafter design for this application. For other concepts in value-added framing design, consult *Cost Effective Home Building: A Design and Construction Handbook* (NAHBRC, 1994). The document also contains prescriptive span tables for roof framing design.

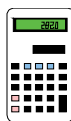

Given

One-story building
 Ridge beam span = 13 ft
 Roof slope = 6:12
 Rafter horizontal span = 12 ft

Loading (chapter 3)
 Dead = 15 psf
 Snow = 20 psf
 Wind (110 mph, gust) = 6.3 psf (inward)
 = 14.2 psf (outward, uplift)
 Live = 10 psf

Find Optimum size and grade of lumber to use for a solid (single-member) ridge beam.

Solution

1. Evaluate load combinations applicable to the ridge beam design (see chapter 3, table 3.1).

$D + (L_r \text{ or } S)$ Controls ridge beam design in the inward-bending direction (compression side of beam laterally supported by top bearing rafters); L_r can be ignored because the roof snow load is greater.

$0.6 D + 0.6 W_u$ May control ridge beam design in outward-bending direction because the bottom (compression side) is laterally unsupported (that is, exposed ridge beam for cathedral ceiling); also important to ridge beam connection to supporting columns. A ridge beam supporting rafters that are tied down to resist wind uplift, however, cannot experience significant uplift without significant upward movement of the rafters at the wall connection and deformation of the entire sloped roof diaphragm (depending on roof slope).

$D + W$ Not controlling because snow load is greater in the inward direction; also, positive pressure is possible only on the sloped windward roof surface, whereas the leeward roof surface is always under negative (suction) pressure for wind perpendicular to the ridge; wind parallel to the ridge results in uplift across both sides of the roof, which is addressed in the $0.6 D + 0.6 W_u$ load combination and the roof uplift coefficients in chapter 3 and based on this worst case wind direction.

2. Determine the ridge beam bending load, shear, and moment for the wind uplift load case.

In accordance with a procedure similar to step 4 of example 5.7, the following ridge beam loads are determined:

$$\text{Rafter sloped span} = \text{horizontal span} / \cos \theta$$

$$\begin{aligned}
 &= 12 \text{ ft} / \cos 26.6^\circ \\
 &= 13.4 \text{ ft} \\
 \text{Load on ridge beam} \\
 W_{\text{dead}} &= (\text{rafter sloped span})(15 \text{ psf}) \\
 &= [1/2 \text{ rafter span on each side}] \\
 &= (13.4 \text{ ft})(15 \text{ psf}) \\
 &= 201 \text{ plf} \\
 0.6 W_{\text{dead}} &= 121 \text{ plf} \\
 W_{\text{wind}} &= (13.4 \text{ ft})(14.2 \text{ psf}) \cos 26.6^\circ \\
 &= 170 \text{ plf} \\
 0.6 W_{\text{wind}} &= 102 \text{ plf} \\
 W_{\text{total}} &= 102 \text{ plf} - 121 \text{ plf} = -19 \text{ plf (inward or downward)} \\
 \text{Shear, } V_{\text{max}} &= 1/2 w \ell = 1/2 (19 \text{ plf})(13 \text{ ft}) \\
 &= 124 \text{ lb} \\
 \text{Moment, } M_{\text{max}} &= 1/8 w \ell^2 = 1/8 (19 \text{ plf})(13 \text{ ft})^2 \\
 &= 401 \text{ ft-lb}
 \end{aligned}$$

Note: If the rafters are adequately tied down to resist uplift from wind, the ridge beam cannot deform upward without deforming the entire sloped roof diaphragm and the rafter-to-wall connections; therefore, the preceding loads should be considered with reasonable judgment. Ensuring that the structure is appropriately tied together to act as a unit is more important.

3. Determine the ridge beam loading, shear, and moment for the D + S gravity load case.

$$\begin{aligned}
 D + S &= 15 \text{ psf} + 20 \text{ psf} = 35 \text{ psf} \\
 &(\text{pressures are additive because both are gravity loads}) \\
 \text{load on ridge beam} \\
 W_{D+S} &= (13.4 \text{ ft})(35 \text{ psf}) = 469 \text{ plf} \\
 \text{Shear, } V_{\text{max}} &= 1/2 (469 \text{ plf})(13 \text{ ft}) = 3,049 \text{ lb} \\
 \text{Moment, } M_{\text{max}} &= 1/8 (469 \text{ plf})(13 \text{ ft})^2 = 9,908 \text{ ft-lb}
 \end{aligned}$$

4. Determine the optimum ridge beam size and grade based on the preceding bending loads and lateral support conditions.

Note: The remainder of the problem is essentially identical to example 5.7 with respect to determining the strength of the wood member. A trial member size and grade are needed to determine the lumber stresses as well as the lumber property adjustment values, however, and the process of optimizing a lumber species, size, and grade selection from the multitude of choices is iterative and time consuming by hand calculation. Several computerized wood design products on the market can perform the task, but those procedures may not allow for flexibility in design approach or assumptions if the designer is attempting to use recommendations similar to those given in this guide. For this reason, many designers prefer to create their own analysis spreadsheets as a customized personal design aid. The remainder of this problem is left to the reader for experimentation.

5.8 References

- American Institute of Steel Construction (AISC). 2011. *Manual of Steel Construction: Allowable Stress Design*, 9th Edition. Chicago: American Institute of Steel Construction.
- American Iron and Steel Institute (AISI). 1993. *Residential Steel Beam and Column Load/Span Tables*, Publication RG-936. Washington, DC: American Iron and Steel Institute.
- . 2012. *North American Standard for Cold-Formed Steel Framing—Prescriptive Method for One and Two Family Dwellings*, 2007 Edition with Supplement 3 (Reaffirmed 2012). AISI S230-07 w/S3-12. Washington, DC: American Iron and Steel Institute.
- American Society of Agricultural Engineers (ASAE). 1997. *Design Requirements and Bending Properties for Mechanically Laminated Columns* (EP 559). St. Joseph, MI: ASAE.
- American Society of Civil Engineers (ASCE). 2010. *Minimum Design Loads for Buildings and Other Structures*. ASCE 7-10. Reston, VA: ASCE.
- American Society of Testing and Materials (ASTM). 2007. *Standard Practice for Establishing Allowable Properties for Visually-Graded Dimension Lumber from In-Grade Tests of Full-Size Specimens* (D1990-97). West Conshohocken, PA: ASTM.
- . 2012. *Standard Specification for Computing the Reference Resistance of Wood-Based Materials and Structural Connections for Load and Resistance Factor Design* (D5457-93). West Conshohocken, PA: ASTM.
- American Wood Council (AWC). 2012a. *Commentary on the National Design Specification for Wood Construction*. Washington, DC: AWC.
- . 2012b. *National Design Specification for Wood Construction and Supplement*. Washington, DC: AWC.
- . 2012c. *Wood Frame Construction Manual*. Washington, DC: AWC.
- APA—The Engineered Wood Association (APA). 1998a. *Product Design Specification (PDS)*. Tacoma, WA: APA.

- . 1998b. *Product Design Specification (PDS) Supplement*. Tacoma, WA: APA.
- . 2011a. *Engineered Wood Construction Guide*. Tacoma, WA: APA.
- . 2011b. *Load-Span Tables for APA Structural-Use Panels*. Tacoma, WA: APA.
- Applied Technology Council (ATC). 1999. *Minimizing Floor Vibration*. ATC Design Guide 1. Redwood City, CA: ATC.
- Callahan, E. 2004. *Metal Plate Connected Wood Truss Handbook*. Madison, WI: Wood Truss Council of America.
- Douglas, B. K., and P. Line. 1996. “System Effects in Wood Assemblies.” In *Proceedings of the International Wood Engineering Conference*, New Orleans.
- Forest Products Laboratory. 2010. *Wood Engineering Handbook*, 2nd edition. Englewood Cliffs, NJ: Prentice Hall.
- . 2013. *Wood Engineering Handbook*, centennial edition. Englewood Cliffs, NJ: Prentice Hall.
- Forest Products Research Society (FPRS). 1983. “Wall & Floor Systems: Design and Performance of Light Frame Structures.” 7317. Madison, WI: FPRS.
- Gillespie, R. H., D. Countryman, and R. F. Blomquist. 1978. “Structural Design Considerations.” Chapter 3 in *Adhesives in Building Construction*, Agriculture Handbook No. 516. Washington, DC: U.S. Department of Agriculture.
- U.S. Department of Housing and Urban Development (HUD). 1980. *Prevention and Control of Decay in Homes*. Washington, DC: HUD.
- . 1999. *System Performance of Wood Header Assemblies*. Prepared for HUD by the NAHB Research Center. Washington, DC: HUD.
- . 2015. *Durability by Design*. Washington, DC: HUD.
- . 2006. *Moisture Resistant Homes*. Washington, DC: HUD.
- International Code Council (ICC). 2008. *Standard for Residential Construction in High Wind Regions*. ICC-600. Washington, DC: ICC.
- . 2012. *International Residential Code*. Washington, DC: ICC.

- International Code Council Evaluation Services (ICC-ES). 2013. *Power-Driven Staples and Nails*. ESR-1539. Whittier, CA, ICC-ES.
- Mtenga, P. V. 1998. "Impact of Using a System Factor in the Design of Light-Frame Roof Assemblies," *Forest Products Journal* 48 (5): 27–34.
- National Association of Home Builders (NAHB). 1961. *Bridging in Residential Floor Construction, LR-6*. Washington, DC: NAHB.
- National Association of Home Builders Research Center (NAHBRC). 1981. *NAHB Beam Series*. Washington, DC: NAHB.
- . 1994. *Cost Effective Home Building: A Design and Construction Handbook*. Upper Marlboro, MD: NAHB
- . 1998. *Prescriptive Method for Residential Cold-Formed Steel Framing*, 3rd Edition. Upper Marlboro, MD: NAHB.
- National Institute of Standards and Technology (NIST). 2009. *Voluntary Product Standard for Construction and Industrial Plywood (USDOC PS 1)*. Gaithersburg, MD: NIST.
- . 2010a. *American Softwood Lumber Voluntary Product Standard (USDOC PS 20)*. Gaithersburg, MD: NIST.
- . 2010b. *Voluntary Performance Standard for Wood-Based Structural-Use Panels (USDOC PS 2)*. Gaithersburg, MD: NIST.
- Pellicane, P. J., and R. W. Anthony. 1996. "Effect of Adhesives on the Deflection Behavior of Light-Frame Wood Floors." In *Proceedings of the International Wood Engineering Conference*, Vol. 3. Madison, WI: Omnipress.
- Polensek. 1975. *Rational Design Procedures for Wood Stud Walls under Bending and Compression Loads*. Forest Research Laboratory, Oregon State University, Corvallis, OR: OSU.
- Rosowsky, D., and B. Ellingwood, 1992. "Reliability of Wood Systems Subjected to Stochastic Live Loads," *Wood and Fiber Science* 24 (1): 47–59.
- Truss Plate Institute (TPI). 2007a. *National Design Standard for Metal Plate Connected Wood Truss Construction (TPI-1-07)*. Madison, WI: TPI.

- . 2007b. *Commentary and Appendices to the National Design Standard for Metal Plate Connected Wood Truss Construction* (TPI-1-07). Madison, WI: TPI.
- Tucker, B. J., and K. J. Fridley. 1999. “Concentrated Load Design Procedures for Wood-Joist Floor Systems,” *Journal of Structural Engineering* 125 (7): 706–712.
- Woeste, L. F., and J. D. Dolan. 1998. “Beyond Code: Preventing Floor Vibration,” *Journal of Light Construction* November: 69–71.
- Wolfe, R. W. 1990. “Performance of Light-Frame Redundant Assemblies.” In *Proceedings of 1990 International Timber Engineering Conference*, vol. 1: 124–131. Madison, WI: Omnipress.
- Wolfe, R. W. 1991. “Structural Performance of Light-Frame Truss-Roof Assemblies.” *Proceedings of the International Wood Engineering Conference*, vol. 3. Madison, WI: Omnipress.
- Wolfe, R.W. 1996. “Structural Performance of Light-Frame Truss-Roof Assemblies.” *Proceedings of the International Wood Engineering Conference*, vol. 3. Madison, WI: Omnipress.
- Wolfe, R. W., and T. LaBissoniere. 1991. *Structural Performance of Light-Frame Roof Assemblies, II. Conventional Truss Assemblies*, FPL-RP-499. Madison, WI: USDA Forest Products Laboratory.
- Wood Truss Council of America (WTCA). 1999. *Commentary for Permanent Bracing of Metal Plate Connected Wood Trusses*. Madison, WI: WTCA.
- . 2008. *Standard Practice for Metal Plate Connected Wood Truss Design Responsibilities* (WTCA 1-95). Madison, WI: WTCA.



CHAPTER 6

Lateral Resistance to Wind and Earthquakes

6.1 General

The objectives in designing a building's lateral resistance to wind and earthquake forces are to protect the health, safety, and welfare of the general public by minimizing risk to life that can potentially result from both structural and nonstructural damage (FEMA, 2003).

In light-frame construction, the lateral-force-resisting system (LFRS) comprises shear walls, diaphragms, and their interconnections to form a whole-building system that may behave differently from the sum of its individual parts. In fact, shear walls and diaphragms are themselves subassemblies of many parts and connections; thus, designing an efficient LFRS system is perhaps the greatest challenge in the structural design of light-frame buildings. One key component of a viable lateral design is ensuring that the load path is provided from the roof down through the walls and floor diaphragms into the foundation and eventually the soil. This can be more difficult when shear walls are not stacked directly on top of one another, necessitating hardware and specific details to drag shear to parts of the building that are designed to resist lateral forces. In part, the challenge results from the lack of any single design methodology or theory that provides reasonable predictions of complex, large-scale system behavior in conventionally built or engineered light-frame buildings. At times, current design methods depart significantly from observations of system testing or field experience. The desire for open floor plans, two-story foyers, great rooms, and large windows common in modern homes creates a challenge in locating and designing the elements of the LFRS.

The lateral design of light-frame buildings is not a simple endeavor that provides “exact” solutions. By the very nature of the LFRS, the real behavior of light-frame buildings is highly dependent on the performance of building systems, including the interactions of structural and nonstructural components. For example, the nonstructural components in conventional housing (that is, sidings, interior finishes, interior partition walls, and even windows and trim) can account for more than 50 percent of a building’s lateral resistance. The contribution of these components is not considered part of the “designed” LFRS, however, for lack of appropriate design tools and because building code provisions may prohibit such considerations. In addition, the need for simplified design methods inevitably leads to a tradeoff: analytical simplicity for design efficiency.

Designer judgment is a crucial factor that comes into play when the designer selects how the building is to be analyzed and to what extent the analysis is a correct representation of the true design problem. Designer judgment is essential in the early stages of design because the analytic methods and assumptions used to evaluate the lateral resistance of light-frame buildings are not in themselves completely correct representations of the problem.

This chapter focuses on methods for evaluating the lateral resistance of individual subassemblies of the LFRS (that is, shear walls and diaphragms) and the response of the whole building to lateral loads (that is, load distribution). The information and design examples presented in this chapter are intended to provide a useful guide and resource to supplement existing building code provisions.

In seismic design, factors that translate into better performance may not always be obvious. The designer should become accustomed to thinking in terms of the relative stiffness of components that make up the whole building because a system-level response often is expected in earthquakes. Important, too, is an understanding of the inelastic behavior of wood-framed systems that affects the optimization of strength, stiffness, damping, and ductility. Many factors relate to a structural system’s deformation capability and the system’s ability to absorb and safely dissipate energy from abusive cyclic motion in a seismic event.

Although seismic and wind design of wood-framed residential buildings presents some challenges to the designer, significant progress has been made in understanding load paths and therefore meeting code objectives with existing building codes (Filiatrault et al., 2010) and achieving improved performance objectives with alternative methods (van de Lindt et al., 2010). The designer should have reasonable knowledge of the underpinnings of current LFRS design approaches, including their uncertainties and limitations. Design provisions generally are based on an “element-based” approach to engineering and usually provide little guidance about how the various elements perform when assembled in a real building. The next section presents a brief overview of several whole-house lateral load tests, whose conclusions are currently being considered by relevant code committees.

6.2 Overview of Whole-Building Tests

A significant number of full-scale tests of houses and even larger wood-framed buildings have been conducted to gain insight into actual system strength, structural behavior, and system performance. Research prior to the mid-1990s has been summarized and is available in reports by Thurston (1994) and NIST (1998).

One whole-house test program investigated the lateral stiffness and natural frequency of a production-built home (Yokel, Hsi, and Somes, 1973). The study applied a design load simulating a uniform wind pressure of 25 pounds per square foot (psf) to a conventionally built home: a two-story, split-foyer dwelling with a fairly typical floor plan. The maximum deflection of the building was only 0.04 inches and the residual deflection about 0.003 inches. The natural frequency and dampening of the building were 9 hz (0.11 second natural period) and 6 percent, respectively. The testing was nondestructive, such that the investigation yielded no information on “post yielding” behavior; however, the performance was good for the nominal lateral design loads under consideration.

Another whole-house test applied transverse loads without uplift to a wood-framed house. Failure did not occur until the lateral load reached the “equivalent” of a 220 mile-per-hour (mph) wind event without inclusion of uplift loads (Tuomi and McCutcheon, 1974). The house was fully sheathed with 3/8-inch plywood panels, and the number of openings was somewhat fewer than would be expected for a typical home (at least on the street-facing side). The failure took the form of slippage at the floor connection to the foundation sill plate (that is, only one 16d toenail at the end of each joist, and the band joist was not connected to the sill). The connection was somewhat less than what is now required in the United States for conventional residential construction (ICC, 2012b). The racking stiffness of the walls nearly doubled from that experienced before the addition of the roof framing. Also, the simple 2x4 wood trusses were able to carry a gravity load of 135 psf—more than three times the design load of 40 psf. Notably, combined uplift and lateral load, which would be expected in high-wind conditions, was not tested. Further, the test house was relatively small and “boxy” in comparison to modern homes.

Many whole-house tests have been conducted in Australia. In one series of whole-house tests, destructive testing showed that conventional residential construction (only slightly different from that in the United States) was able to withstand 2.4 times its intended design wind load (corresponding to a 115 mph wind speed) without failure of the structure (Reardon and Henderson, 1996). The test house had typical openings for a garage, doors, and windows and had no special wind-resistant detailing. The tests applied a simultaneous roof uplift load of 1.2 times the total lateral load. The drift in the two-story section was 3 millimeters (mm; approximately 1/8 inch) at the maximum applied load, whereas the drift in the open one-story section (that is, an area with no interior walls) was 3 mm at the design load and 20 mm (approximately 3/4 inch) at the maximum applied load.

Again in Australia, a house with fiber cement exterior cladding and plasterboard interior finishes was tested to 4.75 times its “design” lateral load

capacity (Boughton and Reardon, 1984). The walls were restrained with tie rods to resist wind uplift loads, which are required in Australia’s typhoon-prone regions. The roof and ceiling diaphragm was found to be stiff; in fact, the diaphragm rigidly distributed the lateral loads to the walls. The tests suggested that the house had sufficient capacity to resist a wind speed of 65 meters per second (145 mph).

Yet another Australian test of a whole house found that the addition of interior ceiling finishes reduced the deflection (that is, drift) of one wall line by 75 percent (Reardon, 1988, 1989). When cornice trim was added to cover or dress the wall-ceiling joint, the deflection of the same wall was reduced by another 60 percent (roughly 16 percent of the original deflection). The tests were conducted at relatively low load levels to determine the impact of various nonstructural components on load distribution and stiffness.

In the 1990s, several whole-building assembly tests in the United States were conducted to develop and validate sophisticated finite-element computer models (Kasal, Leichti, and Itani, 1994).

In England, researchers have taken a somewhat different approach by moving directly from empirical system data to a simplified design methodology, at least for shear walls (Griffiths and Wickens, 1996). This approach applies various “system factors” to basic shear wall design values to obtain a value for a specific application. System factors account for material effects in various wall assemblies, wall configuration effects (that is, number of openings in the wall), and interaction effects with the whole building. One factor even accounts for the fact that shear loads on wood-framed shear walls in a full brick-veneered building are reduced by as much as 45 percent for wind loads—assuming, of course, that the brick veneer is properly installed and detailed to resist wind pressures.

A number of whole-building tests have been conducted in Japan and the United States by using large-scale shake tables to study the seismic response of whole, light-frame buildings. For many of the whole-building tests conducted in Japan in the 1990s, the associated reports are available only in Japanese (Thurston, 1994). United States-based projects for full-scale testing of light-frame wood buildings have increased since 2000. A 2009 report prepared by the National Association of Home Builders Research Center (NAHB, 2009) provides a good summary of those projects. Filiatrault et al. (2002) tested a rectangular two-story house with an integrated one-car garage. The building was full scale, but overall size was limited to the shake table dimensions; regardless, the test provided state-of-the-art results. The building was designed in accordance with the 1988 Uniform Building Code (ICBO, 1988) and performed well at code level and near-fault records from the 1994 Northridge earthquake. Gypsum wall board (GWB) and stucco were shown to provide a very significant increase in strength and stiffness (Filiatrault et al., 2002). As part of the NEESWood Project (van de Lindt and Gupta, 2006), Filiatrault et al. (2010) conducted full-scale, triaxial tests on a two-story, three-bedroom, 1,800-square-foot townhouse with an integrated two-car garage on the twin shake tables of the State University of New York at Buffalo (figure 6.1). This building also was designed to the 1988 Uniform Building Code (ICBO, 1988). The results showed that for light-frame wood

buildings typical of 1990s California, only moderate damage resulted during a design-level earthquake, whereas significant and costly damage occurred during the maximum credible earthquake (MCE). The test results yielded one key conclusion: that little or no risk to life safety was present at the MCE level. The NEESWood townhouse test confirmed the earlier conclusion that the GWB and stucco added strength and stiffness. Full building results are available in the project report by Christovasilis et al. (2007).

FIGURE 6.1 *Twin Garages on Shake Tables, SUNY Buffalo*



During the California Universities for Research on Earthquake Effects (CUREE)-Caltech project, Mosalam and Mahin (2007) tested a three-story apartment building with a tuck-under garage. Their conclusions confirmed that these types of buildings are prone to torsional response and soft-story collapse.

As part of the NEESWood project, van de Lindt et al. (2010) conducted the world's largest shake table test. Figure 6.2 shows a photograph of the 14,000-square-foot, six-story apartment building ready for testing at Japan's E-defense facility in Miki, Japan. The building was 40-by-60-foot in plan and 56 ft tall. The objectives were to (1) provide a general understanding of how midrise light-frame wood buildings perform in a major earthquake, and (2) provide validation for the performance-based seismic design philosophy developed within the project.

Overall performance was excellent at MCE level, but the test structure was designed at a level expected to provide seismic performance superior to current code (van de Lindt et al., 2013), a method called performance-based design (PBD); PBD is mentioned throughout this guide as an alternative method of design. Full details about the test are available in the project task report (Pei et al., 2010).

FIGURE 6.2 *Six-Story Building on Shake Table, Miki, Japan*

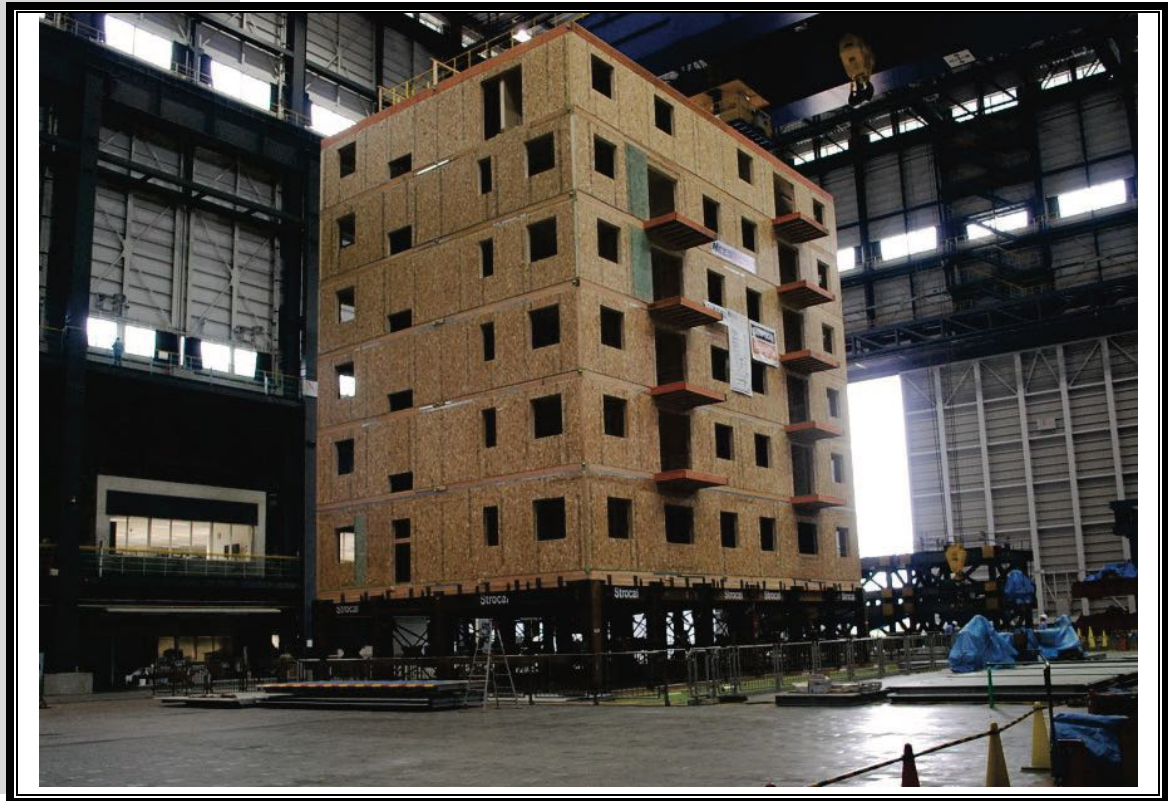

The Insurance Institute for Business and Home Safety has built a full-scale wind tunnel to support the research done for their insurance constituency. To date, the institute has conducted wind testing on several full-scale houses and performed important component testing of siding materials and rooftop equipment. Their full-scale facility also has tested products and systems for wildfire, hail, and wind-driven rain.

The University of Western Ontario has a full-scale wind testing facility called “Three Little Pigs.” That facility has been testing building frames, assemblies, and components with some focus on those elements used in lowrise buildings.

The growing body of whole-building test data will likely improve understanding of the actual performance of light-frame structures in seismic and wind events to the extent that the test programs are able to replicate actual conditions. Actual performance must also be inferred from anecdotal experience

or, preferably, from experimentally designed studies of buildings experiencing major seismic or wind events.

6.3 LFRS Design Steps and Terminology

The LFRS of a home is the “whole house,” including nearly all structural and nonstructural components. To enable a rational and tenable design analysis, however, the complex structural system of a light-frame house is usually subjected to many simplifying assumptions (refer to chapter 2). The following list outlines steps required for thoroughly designing a building’s LFRS in typical order of consideration.

1. Determine a building’s architectural design, including layout of walls and floors (usually predetermined).
2. Design the foundation that will support the load of the structure.
3. Calculate the lateral loads on the structure resulting from wind or seismic conditions (refer to chapter 3).
4. Distribute shear loads to the LFRS (wall, floor, and roof systems), based on one of the design approaches described later in this chapter (refer to section 6.4.1).
5. Determine *shear wall* and *diaphragm* assembly requirements for the various LFRS components (sheathing thickness, fastening schedule, and so forth) to resist the stresses resulting from the applied lateral forces (refer to section 6.5).
6. Design the *hold-down restraints* required to resist overturning forces generated by lateral loads applied to the vertical components of the LFRS (that is, shear walls).
7. Determine interconnection requirements to transfer shear between the LFRS components (that is, roof, walls, floors, and foundation).
8. Evaluate *chords* and *collectors* (or *drag struts*) for adequate capacity and for situations requiring special detailing, such as splices.

Depending on the method of distributing shear loads (refer to section 6.4.1), step 3 may be considered a preliminary design step. If, in fact, loads are distributed according to stiffness in step 3, then the LFRS must already be defined; therefore, the preceding sequence can become iterative between steps 3 and 4. A designer need not feel compelled to go to such a level of complexity (that is, using a stiffness-based force distribution) in designing a simple home, but the decision becomes less intuitive with increasing plan complexity.

The preceding list of design steps introduces several terms that are defined herein.

Horizontal diaphragms are assemblies such as the roof and floors that act as “deep beams” by collecting and transferring lateral forces to the *shear walls*,

which are the vertical components of the LFRS. The diaphragm is analogous to a horizontal, simply supported beam laid flatwise; a shear wall is analogous to a vertical, fixed-end, cantilevered beam. Chapter 2 discussed the function of the LFRS and the lateral load path. The reader is referred to that chapter for a conceptual overview of the LFRS and to chapter 3 for methodologies to calculate lateral loads resulting from wind and earthquake forces.

Chords are the members (or a system of members) that form a “flange” to resist the tension and compression forces generated by the “beam” action of a diaphragm or shear wall. As shown in figure 6.3, the chord members in shear walls and diaphragms are different members, but they serve the same purpose in the beam analogy. A *collector* or *drag strut*, which is usually a system of members in light-frame buildings, “collects” and transfers loads by tension or compression to the shear-resisting segments of a wall line (see figure 6.4a).

In typical light-frame homes, special design of chord members for floor diaphragms may involve some modest detailing of splices at the diaphragm boundary (that is, joints in the band joists). If adequate connection is made between the band joist and the wall top plate, then the diaphragm sheathing, band joists, and wall framing function as a “composite” chord to resist the chord forces; thus, the diaphragm chord is usually integral with the collectors or drag struts in shear walls. Given that the collectors on shear walls often perform a dual role as a chord on a floor or roof diaphragm boundary, the designer needs only to verify that the two systems are reasonably interconnected along their boundary, thus ensuring composite action as well as direct shear transfer (or slip resistance) from the diaphragm to the wall. As shown in figure 6.4b, the failure plane of a typical “composite” collector or diaphragm chord can involve many members and their interconnections.

For shear walls in typical light-frame buildings, tension and compression forces on shear wall chords are usually considered. In particular, the connection of hold-downs to shear wall chords should be carefully evaluated with respect to the transfer of tension forces to the structure below. Tension forces result from the overturning action (that is, the overturning moment) caused by the lateral shear load on the shear wall. In some cases, a thicker chord may be required to allow for an adequate hold-down connection or to withstand the tension and compression forces presumed by the beam analogy. Fortunately, most chords in light-frame shear walls are located at the ends of walls or adjacent to openings, where multiple studs are already required for constructability and gravity load resistance (see cross-section B in figure 6.3).

FIGURE 6.3

Chords in Shear Walls and Horizontal Diaphragms Using the “Deep Beam” Analogy

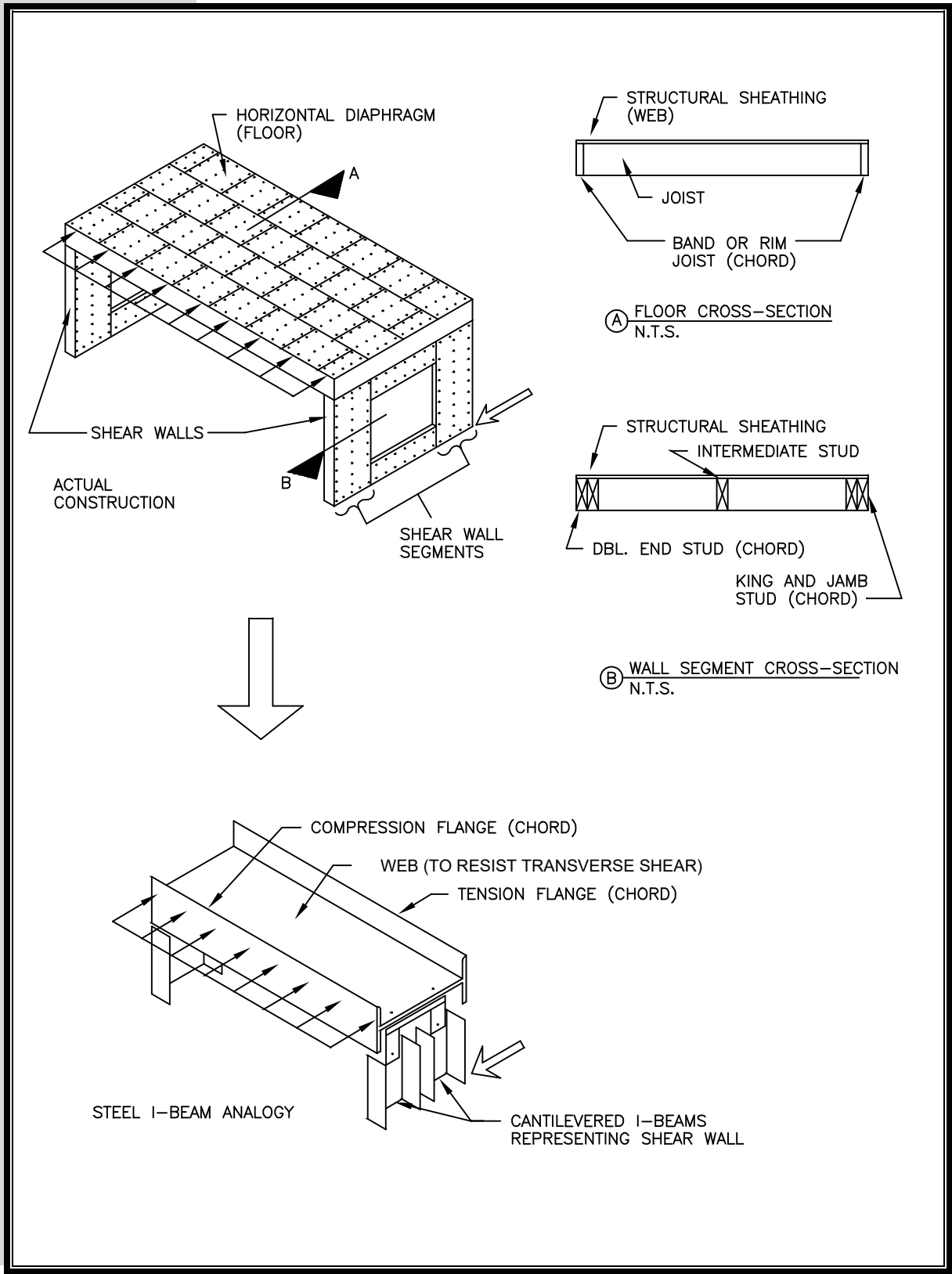
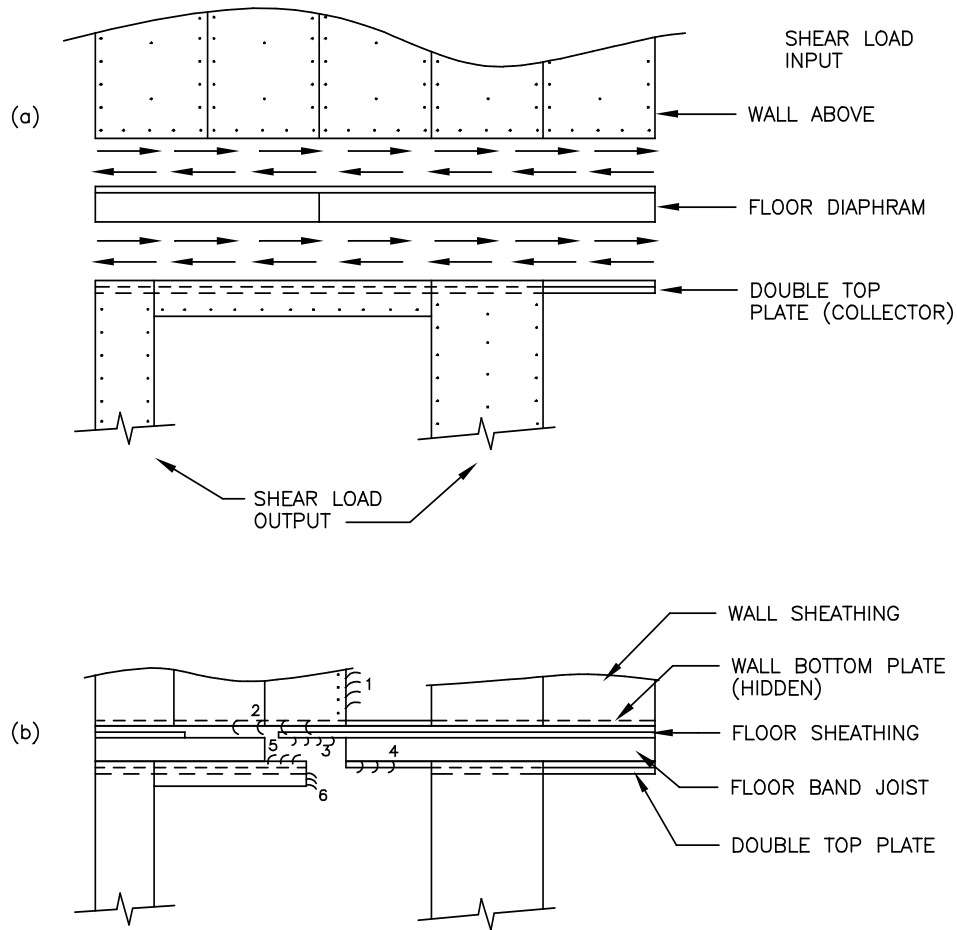

FIGURE 6.4 *Shear Wall Collector and Composite Failure Plane*



COMPOSITE FAILURE PLANE FOR A COLLECTOR:

1. SHEATHING FASTENERS AT COMMON WALL STUD
2. WALL BOTTOM PLATE FASTENERS
3. FLOOR SHEATHING FASTENERS
4. DOUBLE TOP PLATE SPLICE NAILS
5. SHEATHING FASTENERS AT REGION OF DOUBLE TOP PLATE SPLICE
6. SHEATHING AND HEADER FASTENERS TO KING STUD

Hold-down restraints are devices used to restrain the whole building and individual shear wall segments from the overturning that results from the overturning moment created by lateral forces. The current engineering approach calls for restraints that are typically metal connectors (that is, straps or brackets) that attach to and anchor the chords (that is, end studs) of shear wall segments (see figure 6.5a). In many typical residential applications, however, overturning forces may be resisted by the dead load and the contribution of many component connections (see figure 6.5b). Unfortunately (but in reality), this consideration may require a more intensive analytic effort and greater degree of designer presumption because overturning forces may disperse through many “load paths” in a nonlinear fashion. Consequently, the analysis of overturning becomes much more complicated; the designer cannot simply assume a single load path through a single hold-down connector. Indeed, analytic knowledge of overturning has not matured sufficiently to offer an exact, performance-based solution, even though experience suggests that the resistance provided by conventional framing has proven adequate to prevent collapse in all but the most extreme conditions or misapplications (see section 6.2).

Framing and fastenings at wall corner regions are major factors in explaining the actual behavior of conventionally built homes, yet no method is currently recognized to account for this effect. Several studies have investigated corner framing effects in restraining shear walls without using hold-down brackets. In one such study, cyclic and monotonic tests of typical 12-ft long wood-framed shear walls with 2- and 4-ft corner returns demonstrated that overturning forces can be resisted by reasonably detailed corners (that is, sheathing fastened to a common corner stud), with the reduction in shear capacity only about 10 percent from that realized in tests of walls with hold-downs instead of corner returns (Dolan and Heine, 1997c). The corner framing approach can also improve ductility (Dolan and Heine, 1997c); that result has been confirmed by testing in other countries (Thurston, 1994). Such corner or transverse wall detailing is recognized in the conventional IRC wall bracing methods; however, engineering design of shear walls is based on the assumption that proper anchorage and overturning restraint is provided.

FIGURE 6.5

Two Types of Hold-Down Restraint and Basic Analytic Concepts

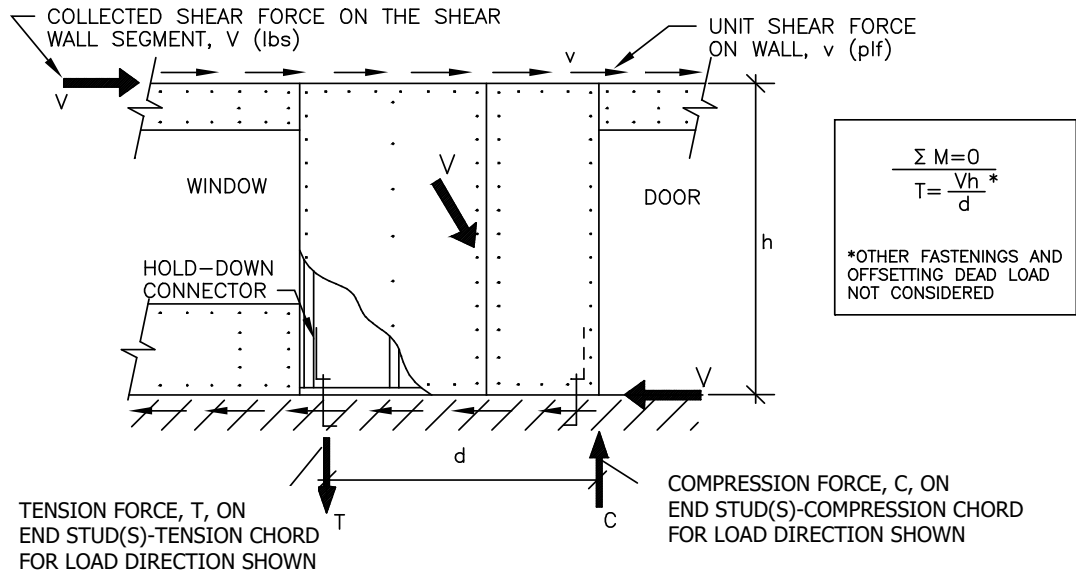

(a) DISCRETE HOLD-DOWN CONNECTOR FOR OVERTURNING RESTRAINT (SIMPLIFIED ANALYSIS)

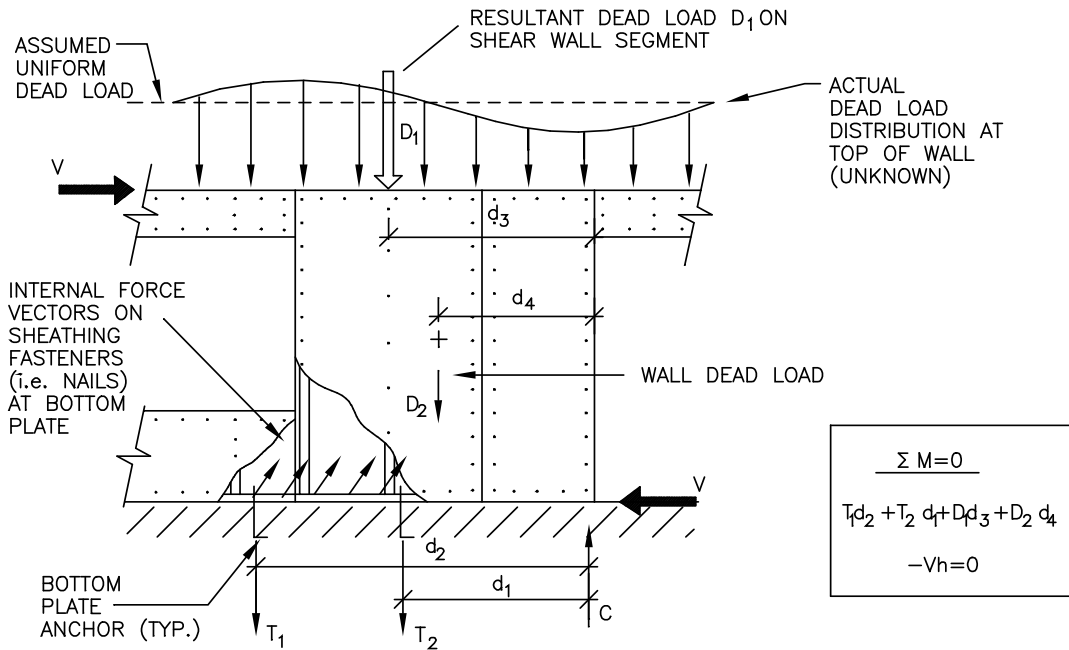

(b) SYSTEM OF FASTENINGS AND DEAD LOAD FOR OVERTURNING RESTRAINT AND SHEAR TRANSFER (COMPLEX ANALYSIS)

6.4.1 The Current LFRS Design Practice

This section provides a brief overview of the current design practices for analyzing the LFRS of light-frame buildings. It highlights the advantages and disadvantages of the various approaches but, in the absence of a coherent body of evidence, makes no attempt to identify which approach, if any, may be considered superior. Where experience from whole-building tests and actual building performance in real events permits, the discussion provides a critique of current design practices that, for lack of better methods, relies somewhat on an intuitive sense for the difference between the structure as it is analyzed and the structure as it may actually perform. The intent is not to downplay the importance of engineering analysis; rather, the designer should understand the implications of the current analytic methods and their inherent assumptions and then put them into practice in a suitable manner.

6.4.1 Lateral Force Distribution Methods

The design of the LFRS of light-frame buildings generally follows one of three approaches, which are described herein. Each differs in its approach to distributing whole-building lateral forces through the horizontal diaphragms to the shear walls. Each also varies in the level of calculation, precision, and dependence on designer judgment. Although different solutions can be obtained for the same design by using the different methods, one approach is not necessarily preferred to another. All may be used for the distribution of seismic and wind loads to the shear walls in a building; however, some of the most recent building codes may place limitations on or display preferences for certain methods.

Tributary Area Approach (Flexible Diaphragm)

The *tributary area approach* is perhaps the most popular method used to distribute lateral building loads. Tributary areas based on building geometry are assigned to various components of the LFRS to determine the wind or seismic loads on building components (that is, shear walls and diaphragms). The method assumes that a diaphragm is relatively flexible in comparison to the shear walls such that it distributes forces according to tributary areas rather than according to the stiffness of the supporting shear walls. This hypothetical condition is analogous to conventional beam theory, which assumes rigid supports (as illustrated in figure 6.6 for a continuous horizontal diaphragm (or floor) with three supports (that is, shear walls).

FIGURE 6.6

**Lateral Force Distribution by a “Flexible” Diaphragm
(Tributary Area Approach)**

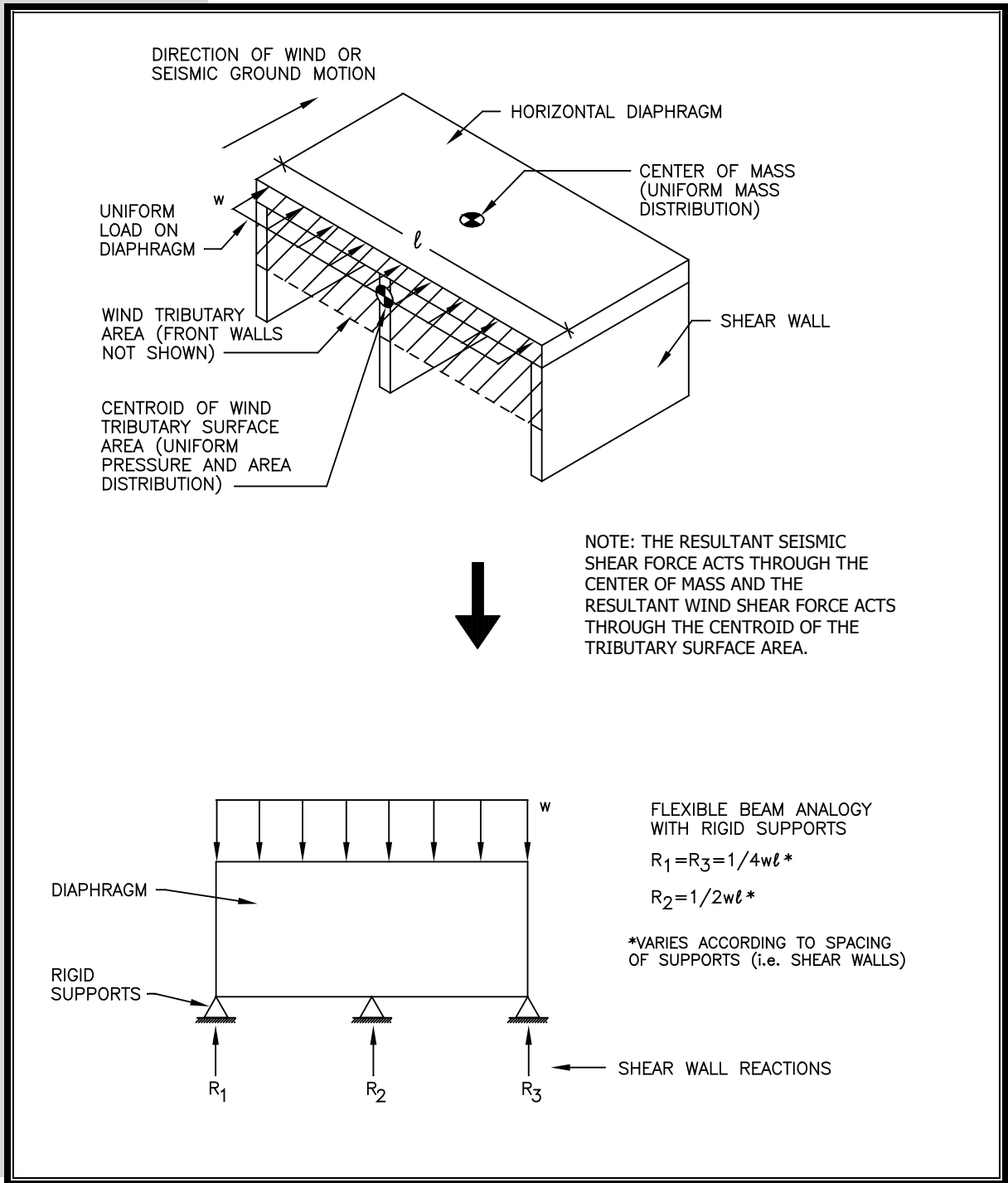

In seismic design, tributary areas are associated with uniform area weights assigned to the building systems (that is, roof, walls, and floors) that generate the inertial seismic load when the building is subject to lateral ground motion (refer to chapter 3 on earthquake loads). In wind design, the tributary areas are associated

with the lateral component of the wind load acting on the exterior surfaces of the building (refer to chapter 3 on wind loads).

The flexibility of a diaphragm depends on its construction as well as on its aspect ratio (length to width). Long, narrow diaphragms, for example, are more flexible in bending along the long dimension than are short, wide diaphragms. In other words, rectangular diaphragms are relatively stiff in one loading direction and relatively flexible in the other. Similarly, long shear walls with few openings are stiffer than walls comprising only narrow shear wall segments. Although analytic methods are available to calculate the stiffness of shear wall segments and diaphragms (refer to section 6.5), the actual stiffness of these systems is extremely difficult to predict accurately (refer to section 6.2). If the diaphragm is considered infinitely rigid relative to the shear walls, and the shear walls have roughly equivalent stiffness, the three shear wall reactions will be roughly equivalent (that is, $R_1 = R_2 = R_3 = 1/3[w][I]$). Were this assumption more accurate, the interior shear wall would be overdesigned and the exterior shear walls underdesigned using the tributary area method. In many cases, the correct solution is probably somewhere between the apparent overdesign and underdesign conditions.

The tributary area approach is reasonable when the layout of the shear walls is generally symmetrical with respect to even spacing and similar strength and stiffness characteristics. The method is particularly appropriate in concept for simple buildings with diaphragms supported by two exterior shear wall lines (with similar strength and stiffness characteristics) along both major building axes. More generally, the major advantages of the tributary area LFRS design method are its simplicity and applicability to simple building configurations. In more complex applications, the designer should consider possible imbalances in shear wall stiffness and strength that may cause or rely on torsional response to maintain stability under lateral load (see the next section, “Relative Stiffness Approach”).

Relative Stiffness Approach (Rigid Diaphragm)

The *relative stiffness approach* was first contemplated for house design in the 1940s. An extensive testing program began, which created a database of racking stiffnesses for a multitude of interior and exterior wall constructions used in residential construction at that time (NBS, 1948). If the horizontal diaphragm is considered stiff relative to the shear walls, then the lateral forces on the building are distributed to the shear wall lines according to their relative stiffness. A stiff diaphragm may then rotate some degree to distribute loads to all walls in the building, not just to walls parallel to an assumed loading direction. Thus, the relative stiffness approach considers torsional load distribution as well as distribution of the direct shear loads. When torsional force distribution must be considered, whether to demonstrate lateral stability of an “unevenly” braced building or to satisfy a building code requirement, the relative stiffness design approach is the only available option.

Although the approach is conceptually correct and comparatively more rigorous than the tributary area approach, its limitations with respect to reasonably determining the real stiffness of shear wall lines (composed of several restrained and unrestrained segments and nonstructural components) and diaphragms (also affected by nonstructural components and the building plan configuration) render its analogy to actual structural behavior uncertain. Ultimately, the method is only as good as the assumptions regarding the stiffness of shear walls and diaphragms relative to the actual stiffness of a complete building system. As evidenced in the previously mentioned whole-building tests and in other authoritative design texts on the subject (Ambrose and Vergun, 1987), difficulties in accurately predicting the stiffness of shear walls and diaphragms in actual buildings are significant. Moreover, unlike the other methods, the relative stiffness design approach is iterative in that the distribution of loads to the shear walls requires a preliminary design so that relative stiffness may be estimated. One or more adjustments and recalculations may be needed before reaching a satisfactory final design.

Analytically considering the effects of stiffness in the distribution of lateral forces in an LFRS is instructional, however, even if based on somewhat idealized assumptions regarding relative stiffness (that is, the diaphragm is rigid over the entire expanse of shear walls). The approach is a reasonable tool when the torsional load distribution should be considered in evaluating or demonstrating the stability of a building, particularly a building that is likely to undergo significant torsional response in a seismic event. Indeed, torsional imbalances exist in just about any building and may be responsible for the relatively good performance of some light-frame homes when one side (that is, the street-facing side of the building) is weaker (that is, less stiff and less strong) than the other three sides of the building. This condition is common because of the aesthetic desire and functional need for more openings on the front side of a building; however, a torsional response in the case of underdesign (that is, “weak” or “soft” story) can wreak havoc on a building and constitute a serious threat to life.

Total Shear Approach

Considered one of the most popular and the simplest of the three LFRS design methods, the *total shear approach* uses the total story shear to determine the total amount of shear wall length required on a given story level for each orthogonal direction of loading. The amount of shear wall is then “evenly” distributed in the story, according to designer judgment. Although the total shear approach requires the least amount of computational effort among the three methods, it demands good judgment as to the distribution of the shear wall elements to address or avoid potential loading or stiffness imbalances. In seismic design, loading imbalances may be created when a building’s mass distribution is not uniform. In wind design, loading imbalances result when the surface area of the building is not uniform (that is, taller walls or steeper roof sections experience greater lateral wind load). In both cases, imbalances are created when the center of resistance is offset from either the center of mass (seismic design) or the resultant force center of the exterior surface pressures (wind design). Thus, the

reliability of the total shear approach is highly dependent on the designer's judgment and intuition regarding load distribution and structural response. If used indiscriminately without consideration of the factors mentioned, the total shear approach to LFRS design can result in poor performance in severe seismic or wind events. For small structures such as homes, however, the method has produced reasonable designs, especially in view of the overall uncertainty in seismic and wind load analysis.

6.4.2 Shear Wall Design Approaches

Once the whole-building lateral loads have been distributed and assigned to the floor and roof diaphragms and various designated shear walls, each of these subassemblies must be designed to resist the assigned shear loads. As discussed, the whole-building shear loads are distributed to various shear walls ultimately in accordance with the principle of relative stiffness (whether handled by judgment, analytic assumptions per a selected design method, or both). Similarly, the distribution of the assigned shear load to the various shear wall segments within a given shear wall line is based on the same principle but at a different scale. The scale is the subassembly (or shear wall) as opposed to the whole building.

The methods for designing and distributing the forces within a shear wall line differ, as described herein. As with the two different approaches described for the distribution of lateral building loads, the shear wall design methods place different levels of emphasis on analytic rigor and judgment. Ultimately, the configuration of the building (that is, whether the walls are inherently broken into individual segments by large openings or many offsets in plan dimensions) and the required demand (that is, shear load) should drive the choice of a shear wall design approach and the resulting construction detailing. Thus, the choice of which design method to use is a matter of designer judgment and required performance. In turn, the design method itself imposes detailing requirements on the final construction, in compliance with the analysis assumptions. Accordingly, those decisions affect the efficiency of the design effort and the complexity of the resulting construction details.

Segmented Shear Wall Approach

The *segmented shear wall (SSW) approach*, well recognized as a standard design practice, is the most widely used method of shear wall design. It considers the shear resisting segments of a given shear wall line as separate “elements,” with each segment restrained against overturning by the use of hold-down connectors at its ends. Each segment is a fully sheathed portion of the wall without any openings for windows or doors. The design shear capacity of each segment is determined by multiplying the length of the segment (sometimes called segment width) by tabulated unit shear design values, which are available in the building codes and newer design standards. In its simplest form, the

approach analyzes each shear wall segment for static equilibrium in a manner analogous to a cantilevered beam with a fixed end (refer to figures 6.3 and 6.5a). In a wall with multiple designated shear wall segments, the typical approach to determining an adequate total length of all shear wall segments is to divide the design shear load demand on the wall by the unit shear design value of the wall construction. The effect of stiffness on the actual shear force distribution to the various segments is simply handled by complying with maximum shear wall segment aspect ratios required by code (that is, segment height divided by segment width). Although an inexact method of handling the problem of shear force distribution in a shear wall line, the SSW approach has been in successful practice for many years, partly because it uses conservative unit shear design values.

The stiffness of a shear wall segment is assumed to be linearly related to its length (or its total design shear strength); however, the linear relationship is not realistic outside certain limits. For example, stiffness begins to decrease with notable nonlinearity once a shear wall segment decreases below a 4-ft length on an 8-ft high wall (that is, it has an aspect ratio of 2 or greater). This does not mean that wall segments shorter than 4 feet in width cannot be used but rather that the designer must consider the effect of relative stiffness in distributing the load. The SSW approach is also less favorable when the wall as a system rather than individual segments (that is, including sheathed areas above and below openings) may be used to economize on design while meeting performance requirements (see the section, “Basic Perforated Shear Wall Approach, which follows).

As shown in figure 6.5, designers commonly either neglect the contribution of dead load or assume that the dead load on the wall is uniformly distributed, as would be the case under gravity loading only. In fact, unless the wall is restrained with an infinitely rigid hold-down device (an impossibility), the uniform dead load distribution will be altered as the wall rotates and deflects upward during the application of shear force (see figure 6.5b). As a result, depending on the rigidity of the framing system above, the dead load will tend to concentrate more toward the “high points” in the wall line, as the various segments begin to rotate and uplift at their leading edges. Thus, the dead load may be somewhat more effective in offsetting the overturning moment on a shear wall segment than is suggested by the uniform dead load assumption. Unfortunately, this phenomenon involves nonrigid body, nonlinear behavior for which no simplified methods of analysis exist. That effect is generally not considered, therefore, particularly for walls with specified restraining devices (that is, hold-downs) that are, by default, generally assumed to be completely rigid—an assumption that is known through testing not to hold true to varying degrees, depending on the type of device and its installation.

Basic Perforated Shear Wall Approach

The *basic perforated shear wall (PSW) approach* is gaining popularity among designers. A PSW is a wall that is fully sheathed with wood structural panels (that is, oriented strand board or plywood) and that has openings or

“perforations” for windows and doors. The ends of the walls—rather than each individual segment, as in the SSW approach—are restrained against overturning. As for the intermediate segments of the wall, they are restrained by conventional or designed framing connections, such as those at the base of the wall that transfer the shear force resisted by the wall to the construction below. The capacity of a PSW is determined as the ratio of the strength of a wall with openings to the strength of a wall of the same length without openings. The ratio is calculated by using two empirical equations, which are given in section 6.5. Figure 6.7 illustrates a PSW.

FIGURE 6.7 *Basic Perforated Shear Wall*

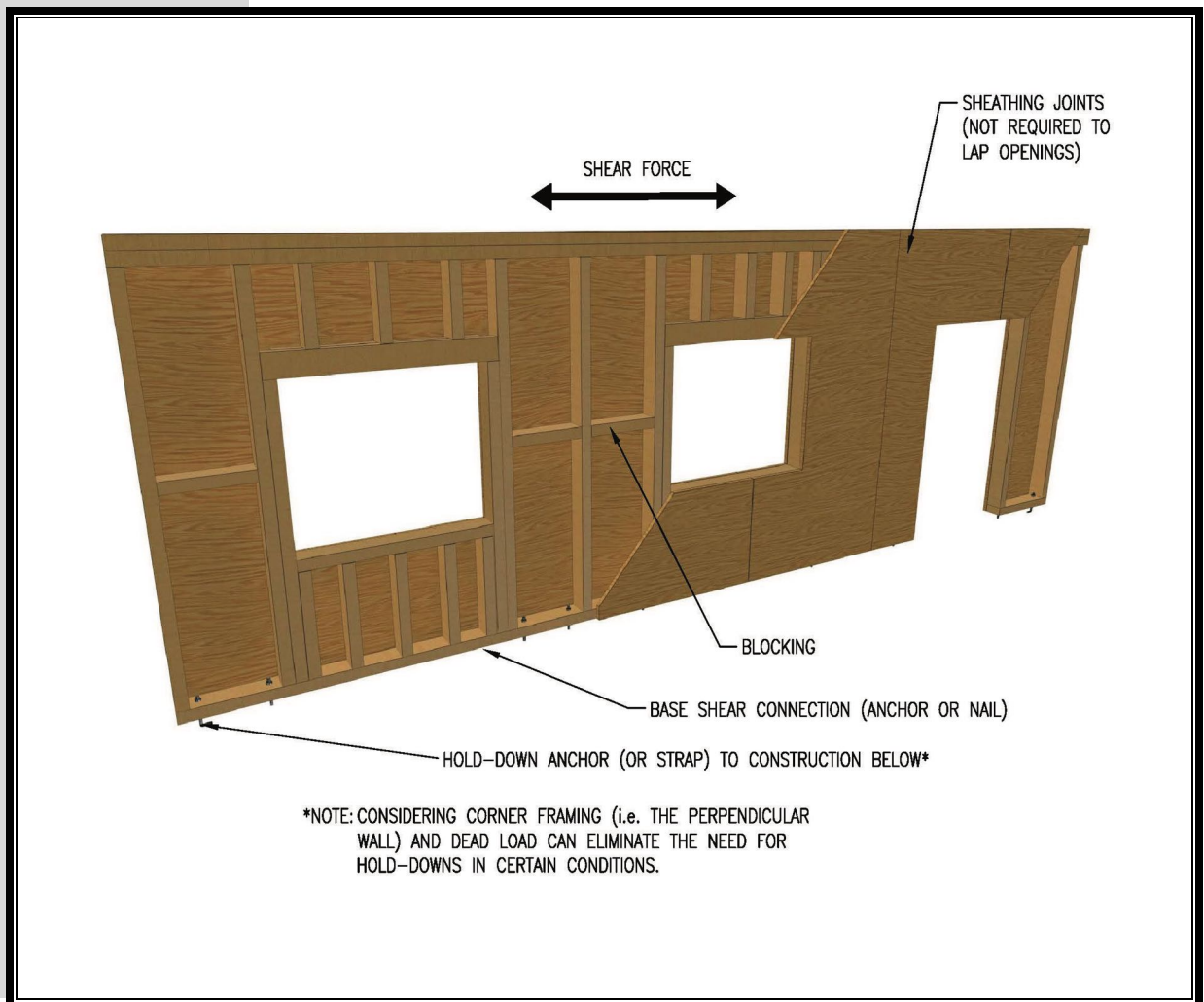

The PSW design method requires the least amount of special construction detailing and analysis among the current shear wall design methods. It has been validated in several recent studies in the United States but dates back more than 20 years to research first conducted in Japan (Dolan and Heine, 1997a, 1997b; Dolan and Johnson, 1996a, 1996b; NAHB, 1997, 1998, 1999; Ni et al., 1999;

Sugiyama and Matsumoto, 1994). Although it produces the simplest form of an engineered shear wall solution, other methods, such as the SSW design method—all other factors equal—can yield a stronger wall. Conversely, a PSW design with increased sheathing fastening can outperform an SSW with more hold-downs but weaker sheathing fastening. The point is that for many applications the PSW method often provides an adequate and more efficient design; therefore, it should be considered an option to the SSW method, as appropriate.

Force Transfer Around Openings in Shear Walls

Wall openings for windows and doors can greatly reduce shear wall resistance because of the discontinuity of the load transfers, as well as high force concentration around openings. The force transfer around openings (FTAO) approach is one of the more recent solutions that designers have been using. This method consists of shear walls designed and detailed for FTAO so that nails, metal straps, and blocking members may be utilized to transfer loads and reinforce corners of openings. In the FTAO method, a rational engineer-based analysis is required to estimate the force transfer and choose proper metal connectors (Li et al., 2012).

Partially Restrained Shear Wall Design

Modern residential designs frequently create larger, more open spaces than home designs have in the past, yet the wall bracing provisions in the codes have been largely based on historic practice. The larger, open floor plans provide less wall area to resist large lateral forces from either wind or seismic events. Partially restrained shear walls consider larger braced wall line spacing, braced wall lines that extend beyond the locations of overturning restraints, offsets of braced wall lines, and other braced wall line conditions that are not completely consistent with a standard SSW approach. Shear strength adjustment factors have been developed to account for these braced wall line anomalies and are included in the IRC prescriptive braced wall tables. The shear strength adjustment factors for both wind and seismic braced walls are provided in section R602 in the IRC (ICC, 2012b) (Crandell and Martin, 2009).

6.4.3 Basic Diaphragm Design Approach

As described in chapter 2 and earlier in this section, horizontal diaphragms are designed by using the analogy of a deep beam laid flatwise. Thus, the shear forces in the diaphragm are calculated as for a beam under a uniform load (refer to figure 6.6). As is similar to the case of shear walls, the design shear capacity of a horizontal diaphragm is determined by multiplying the diaphragm depth (that is, depth of the analogous deep beam) by the tabulated unit shear design values found in building codes. The chord forces (in the “flange” of the analogous deep beam) are calculated as a tension force and compression force on opposite sides

of the diaphragm. The two forces form a force couple (that is, moment) that resists the bending action of the diaphragm.

To simplify the calculation, the designer commonly assumes that the chord forces are resisted by a single chord member that serves as the “flange” of the deep beam (that is, a band joist). At the same time, bending forces internal to the diaphragm are assumed to be resisted entirely by the boundary member or band joist rather than by other members and connections within the diaphragm. In addition, other parts of the diaphragm boundary (that is, walls) that also resist the bending tension and compressive forces are not considered. Certainly, a vast majority of residential roof diaphragms that are not considered “engineered” by current diaphragm design standards have exhibited ample capacity in major design events. Thus, the beam analogy used to develop an analytic model for the design of wood-framed horizontal diaphragms has room for improvement that has yet to be explored from an analytic standpoint. The designer should note, however, that the wall top plates often are considered the chord and collector member in engineering design—so the engineering model is not out of line with what is provided in conventional construction.

As with shear walls, openings in the diaphragm affect the diaphragm’s capacity; however, no empirical design approach accounts for the effect of openings in a horizontal diaphragm as the PSW method does for shear walls. If openings are present, therefore, the effective depth of the diaphragm in resisting shear forces must either discount the depth of the opening or be designed for shear transfer around the opening. If shear forces must be transferred around a large opening in a diaphragm, the designer commonly performs a mechanics-based analysis of the shear transfer around the opening. The analysis is similar to the previously described method that uses free-body diagrams for the design of shear walls. The reader should refer to other sources for further study of diaphragm design (Ambrose and Vergun, 1987; APA, 2007; Diekmann, 1986).

6.5 Design Guidelines

6.5.1 General Approach

This section outlines methods for designing shear walls (section 6.5.2) and diaphragms (section 6.5.3). The two methods of shear wall design are the SSW and PSW methods. The selection of a method depends on shear loading demand, wall configuration, and the desired simplicity of the final construction. Regardless of design method and resulting LFRS, the first consideration is the amount of lateral load to be resisted by the arrangement of shear walls and diaphragms in a given building. The design loads and basic load combinations that include lateral loads in chapter 3, table 3.1, are as follows.

- $D + 0.75(0.6W) + 0.75L + 0.75(L_r \text{ or } S \text{ or } R)$ ASD
- $D + 0.75(0.7E) + 0.75L + 0.75S$ ASD
- $0.6D + 0.6W$ ASD

- $0.6D + 0.7E$ ASD
- $0.9D + (1.0W \text{ or } 1.0E)$ LRFD

Earthquake load and wind load are considered separately, with shear walls designed in accordance with more stringent loading conditions. Even when wind governs the design of the LFRS, seismic detailing requirements might still be necessary.

Lateral building loads should be distributed to the shear walls on a given story by using one of the following methods, as deemed appropriate by the designer.

- Tributary area approach.
- Total shear approach.
- Relative stiffness approach.

These methods were described earlier (see section 6.4). In the case of the tributary area method, the loads can be immediately assigned to the various shear wall lines based on tributary building areas (exterior surface area for wind loads and building plan area for seismic loads) for the two orthogonal directions of loading (assuming rectangular-shaped buildings and relatively uniform mass distribution for seismic design). In the case of the total shear approach, the load is considered as a “lump sum” for each story for both orthogonal directions of loading. The shear wall construction and total amount of shear wall for each direction of loading and each shear wall line are then determined in accordance with this section to meet the required load as determined by either the tributary area or total shear approach. The designer must be reasonably confident that the distribution of the shear walls and their resistance is reasonably “balanced” with respect to building geometry and the center of the total resultant shear load on each story. As mentioned, both the tributary and total shear approaches have produced many serviceable designs for typical residential buildings, provided that the designer exercises sound judgment.

In the case of the relative stiffness method, the assignment of loads must be based on an assumed relationship describing the relative stiffness of various shear wall lines. Generally, the stiffness of a wood-framed shear wall is assumed to be directly related to the length of the shear wall segments and the unit shear value of the wall construction. The PSW method may assume the relative stiffness of various PSW lines to be directly related to the design strength of the various PSW lines. Using the principle of moments and a representation of wall racking stiffness, the designer can then identify the center of shear resistance for each story and determine each story’s torsional load (because of the offset of the load center from the center of resistance). Finally, the designer superimposes direct shear loads and torsional shear loads to determine the estimated shear loads on each of the shear wall lines.

Design example 6.5 of section 6.6 elaborates on and demonstrates the use of the methods of load distribution described. The reader is encouraged to study

and critique them. The example contains many concepts and insights that cannot be otherwise conveyed without the benefit of a “real” problem.

6.5.2 Shear Wall Design

6.5.2.1 Shear Wall Design Values (F_s)

This section provides unfactored (ultimate) unit shear values for wood-framed shear wall constructions that use wood structural panels (WSPs). Other wall constructions and framing methods are included as an additional resource. The unit shear values given here differ from those in the current codes in that they are based explicitly on the ultimate shear capacity as determined through testing. The designer should refer to the applicable building code for “code-approved” unit shear values, therefore. This guide uses ultimate unit shear capacities as its basis to give the designer an explicit measure of the actual capacity and safety margin (that is, reserve strength) used in design and to provide for a more consistent safety margin across various shear wall construction options. Accordingly, it is imperative that the values used in this guide be appropriately adjusted in accordance with sections 6.5.2.2 and 6.5.2.3 to ensure an acceptable safety margin.

Wood Structural Panels

Table 6.1 provides unit shear values for walls sheathed with WSPs that are used according to current building codes. Although the actual capacity of a shear wall may not be explicitly known to the designer using the codes’ allowable unit shear values, one alleged benefit of using the code-approved design unit shear values is that the values are believed to address drift implicitly by way of a generally conservative safety margin. Even so, shear wall drift usually is not analyzed in residential construction for reasons stated previously.

The values in table 6.1 are based primarily on monotonic tests (that is, tests that use single-direction loading). Recently, the effect of cyclic loading on wood-framed shear wall capacity has generated considerable controversy. Depending on the cyclic test protocol, the resulting unit shear values may be above or below those obtained from traditional monotonic shear wall test methods (ASTM, 2010, 2012). In fact, realistic cyclic testing protocols and their associated interpretations were found to be largely in agreement with the results obtained from monotonic testing (Karacabeyli and Ceccotti, 1998). A CUREE testing protocol development study (Krawinkler et al., 2000) found that, for WSP walls, the backbone curves from cyclic testing reasonably matched monotonic testing. Cyclic testing still is very important to understand failures modes and hysteretic behavior and is necessary for all shear wall materials. The differences generally are in the range of 10 percent (plus or minus) and thus are not significant.

The unit shear values in table 6.1 are based on nailed sheathing connections. The use of elastomeric glue to attach WSP sheathing to wood

framing members increases the shear capacity of a shear wall by as much as 50 percent or more (White and Dolan, 1993). Similarly, studies using elastomeric construction adhesive manufactured by 3M Corporation have investigated seismic performance (that is, cyclic loading) and confirm a stiffness increase of about 65 percent and a shear capacity increase of about 45 to 70 percent over sheathing fastened with nails only (Filiatrault and Foschi, 1991). Rigid adhesives may create even greater strength and stiffness increases. The use of adhesives is beneficial in resisting shear loads from wind. Panel manufacturers do not recommend gluing shear wall panels because of

TABLE 6.1

Nominal Shear Resistance (plf) for Wood Structural Panel Shear Walls With Framing of Douglas-Fir, Larch, or Southern Pine^{a, b}

Panel Grade	Nominal Panel Thickness (inches)	Minimum Nail Penetration in Framing (inches) (APA, 1998)	Nail Size (common or galvanized box)	Panels Applied Directly to Framing							
				Nail Spacing at Panel Edges, (inches)							
				Seismic				Wind			
				6	4	3	2	6	4	3	2 ^c
Structural I	5/16	1 1/4	6d	400	600	780	1,020	560	840	1,090	1,430
	3/8 ^d	1 3/8	8d	460	720	920	1,220	645	1,010	1,290	1,710
Structural I	7/16 ^d	1 3/8	8d	510	790	1,010	1,340	715	1,105	1,415	1,875
	15/32	1 3/8	8d	560	860	1,100	1,460	785	1,205	1,540	2,045
	15/32	1 1/2	10d ^e	680	1,020	1,330	1,740	950	1,430	1,860	2,435

plf = pounds per linear foot.

^a Values are average nominal unit shear capacity and should be adjusted to determine allowable stress design or load and resistance factor design-factored resistances. For other rated panels (not Structural I), the table values should be multiplied by 0.85.

^b All panel edges should be backed with 2-inch nominal or wider framing. Panels may be installed either horizontally or vertically. Space nails at 6 inches on center along intermediate framing members for 3/8-inch panels installed, with the strong axis parallel to studs spaced 24 inches on center and 12 inches on center for other conditions and panel thicknesses.

^c Framing at adjoining panel edges should be 3-inch nominal or wider, and nails should be staggered where nails are spaced 2 inches on center. A double thickness of nominal 2-inch framing is a suitable substitute.

^d The values for 3/8- and 7/16-inch panels applied directly to framing may be increased to the values shown for 15/32-inch panels, provided that studs are spaced a maximum of 16 inches on center or the panel is applied with its strong axis across the studs.

^e Framing at adjoining panel edges should be 3-inch nominal or wider, and nails should be staggered where 10d nails penetrating framing by more than 1 5/8 inches are spaced 3 inches or less on center. A double thickness of 2-inch nominal framing is a suitable substitute.

concern with panel buckling that may occur as a result of the interaction of rigid restraints with moisture and temperature expansion and contraction of the panels. Construction adhesives are routinely used in floor diaphragm construction, however, to increase the bending stiffness and strength of floors; in-plane (diaphragm) shear is probably affected by an amount similar to that reported for shear walls.

For unit shear values of WSPs applied to cold-formed steel framing, the designer should consult *Shear Wall Values for Light Weight Steel Framing* (AISI, 1996). Table 6.2 presents some typical unit shear values for cold-formed, steel-framed walls with WSP sheathing fastened with #8 screws. Values for power-driven, knurled pins (similar to deformed shank nails) should be obtained from the manufacturer and the applicable code evaluation reports (ICC-ES, 2013).

TABLE 6.2 *Nominal Unit Shear Resistance (plf) for Walls With Cold-Formed Steel Framing and Wood Structural Panels^{a, b}*

Panel Grade	Panel Type and Nominal Thickness (inches)	Minimum Screw Size ^c	Screw Spacing at Panel Edges (inches) ^d			
			6	4	3	2
Structural I	7/16 OSB	#8	700	915	1,275	1,625
	15/32 plywood	#8	780	990	1,465	1,700

OSB = oriented strand board. plf = pounds per linear foot.

^a Values are average nominal unit shear capacity and should be adjusted to determine allowable stress design or load and resistance factor design-factored resistances.

^b Values apply to 18 gauge (43 mil) and 20 gauge (33 mil) steel C-shaped studs with a 1 5/8-inch flange width and 3 1/2- to 5 1/2-inch depth. Studs are spaced a maximum of 24 inches on center.

^c The #8 screws should have a head diameter of no less than 0.29 inches, and the screw threads should penetrate the framing so that the threads are fully engaged in the steel.

^d The spacing of screws in framing members located in the interior of the panels should be no more than 12 inches on center.

Portland Cement Stucco

Ultimate unit shear values for conventional portland cement stucco (PCS) wall construction range from 490 to 1,580 pounds per linear foot (plf), based on the ASTM E 72 (ASTM, 2010) test protocol and 12 tests conducted by various testing laboratories (ICBO, 1969; Testing Engineers, Inc., 1970, 1971). In general, nailing the metal lath or wire mesh resulted in ultimate unit shear values less than 750 plf, whereas stapling resulted in ultimate unit shear values greater than 750 plf. An ultimate design value of 500 plf is recommended unless specific details of PCS construction are known. A safety factor of 2 provides a conservative allowable design value of about 250 plf. The actual capacity can be as much as five times 250 plf, depending on the method of construction, particularly the means of fastening the stucco lath material. Past code-approved allowable design values are typically about 180 plf, and the AWC seismic and wind design supplement (AWC, 2012) lists 360 plf as an ultimate design value. One legacy code required the values to be further reduced by 50 percent in higher hazard seismic design areas, although the reduction factor may not necessarily improve performance with respect to the cracking of the stucco finish in seismic events (HUD, 1999) (refer to chapter 1 and the discussion in chapter 3 on displacement compatibility under seismic load). Using a lower seismic response modification factor (R) may be more appropriate than increasing the safety margin in a manner that is not explicit to the designer. In fact, an R factor for PCS wood-framed walls is not explicitly provided in building codes (perhaps an R of 2 for wood-framed walls with “shear panels of all other materials” is used). An R

factor for PCS walls should probably be in the range of 3 to 4 (without additional increases in the safety factor) because the metal lath and its connection to wood framing provide some ductility.

The preceding values pertain to PCS that is 7/8-inch thick, with nail or staple fasteners spaced 6 inches on center for attaching the metal wire mesh or lath to all framing members. Nails are typically 11 gauge by 1 1/2 inches in length, and staples typically have 3/4-inch leg and 7/8-inch crown dimensions. The unit shear values recommended also apply to stud spacings no greater than 16 inches on center. Finally, the aspect ratio of stucco wall segments included in a design shear analysis should not be greater than 2 (height/width), according to past building code practice.

Gypsum Wall Board

Ultimate capacities in testing 1/2-inch thick GWB range from 120 to 320 plf, depending on the fastening schedule (Patton-Mallory, Gutkowski, and Soltis, 1984; Wolfe, 1983). Allowable or design unit shear values for GWB sheathing range from 75 to 150 plf in current building codes, depending on the construction and fastener spacing. At least one legacy building code required the values to be reduced by 50 percent in high-hazard seismic design areas (ICBO, 1997). GWB certainly is not recommended as the primary seismic bracing for walls, although it does contribute to the structural resistance of buildings in all seismic and wind conditions. Methods of fastening interior GWB vary and are generally not an “inspected” system. Table 6.3 provides estimated ultimate unit shear values for GWB sheathing.

TABLE 6.3 *Nominal Unit Shear Values (plf) for 1/2-Inch Thick Gypsum Wall-Board Sheathing^{a, b}*

GWB Thickness	Blocking Condition ^c	Spacing of Framing (inches)	Fastener Spacing at Pane Edges (inches)				
			12	8	7	6	4
1/2 inch	Blocked	16	120	210	250	260	320
		16	80	170	200	220	250
	Unblocked	24	40	120	150	180	220

GWB = gypsum wall-board. plf = pounds per linear foot.

^a The values represent average nominal unit shear capacity and should be adjusted to determine allowable stress design or load and resistance factor design-factored resistances.

^b Fasteners should be minimum 1 1/2-inch drywall nails (that is, 5d cooler) or 1-1/4-inch drywall screws (that is, #6 size with bugle head) or equivalent, with spacing of fasteners and framing members as shown.

^c “Blocked” refers to the condition in which all edges of the panels are fastened to framing members; “unblocked” refers to the condition in which the panels are placed horizontally, with horizontal joints between the panels not fastened to blocking, or vertically, with the top and bottom edges fastened only at stud locations.

1x4 Wood Let-in Braces and Metal T-braces

Wood let-in braces and metal T-braces are common in conventional residential construction and add to the shear capacity of walls. Those braces are always used in combination with other wall finish materials that also contribute to a wall's shear capacity. The braces are typically attached to the top and bottom plates of walls and at each intermediate stud intersection with two 8d common nails. Such braces are not recommended for the primary lateral resistance of structures in high-hazard seismic or wind design areas. In particular, values of the seismic response modification factor R for walls braced in this manner have not been clearly defined for standardized seismic design guidance. Design values are available in section R602 of the IRC (ICC, 2012b).

Other Shear-Resisting Wall Facings

Just about any wall facing, finish, or siding material contributes to a wall's shear resistance qualities. Although the total contribution of nonstructural materials to a typical residential building's lateral resistance often is substantial (that is, nearly 50 percent if interior partition walls are included), current design codes in the United States prohibit considerations of the role of facing, finish, or siding. Some suggestions call for a simple and conservative 10-percent increase (known as the "whole-building interaction factor") to the calculated shear resistance of the shear walls, or a similar adjustment to account for the added resistance and whole-building effects not typically considered in design (Griffiths and Wickens, 1996). A comprehensive study by Filiatrault et al. (2010) confirmed this effect of GWB and stucco on building stiffness, strength, and seismic performance.

Some other types of wall sheathing materials that provide shear resistance include particleboard and fiberboard. Nominal unit shear values for fiberboard and particleboard are provided in the *National Design Specification for Wood Construction—Wind and Seismic Supplement* (AWC, 2008). The designer should consult the building code or manufacturer data for additional information on fiberboard and other materials' shear resistance qualities. In one study that conducted tests on various wall assemblies for HUD, fiberboard was not recommended for primary shear resistance in high-hazard seismic or wind design areas because of potential durability and cyclic loading concerns.

Combining Wall Bracing Materials

When wall bracing materials (that is, sheathing) of the same type are used on opposite faces of a wall, the shear values may be considered additive. In high-hazard seismic design conditions, dissimilar materials generally are assumed to be nonadditive. In wind-loading conditions, dissimilar materials may be considered additive for WSPs (exterior) with GWB (interior). A method to add dissimilar materials was proposed as part of the *Seismic Evaluation and Retrofit of Multi-Unit Wood-Frame Buildings with Weak First Stories* (FEMA P-807) seismic

retrofit methodology for soft-story, wood-framed buildings (FEMA, 2012). Chapter 6 of the 2012 IRC provides more guidance on combining of wall bracing materials in various scenarios: on the same wall or wall line, within the same story, and between stories.

When calculating the shear capacity for walls with different facings, the designer must take care to apply the appropriate adjustment factors to determine the wall construction's total design racking strength. Most of the adjustment factors in the following sections apply only to WSP sheathing; therefore, the adjustments in the next section should be made as appropriate before determining combined shear resistance.

6.5.2.2 Shear Wall Design Capacity

The unfactored and unadjusted ultimate unit shear resistance values of wall assemblies should first be determined in accordance with the guidance provided in the previous section for rated facings or structural sheathing materials used on each side of the wall. This section provides methods for determining and adjusting the design unit shear resistance and the shear capacity of a shear wall by using either the PSW or SSW approaches, discussed in section 6.4.2. The design approaches and other important considerations are illustrated in the design examples of section 6.6.

Perforated Shear Wall Design Approach

The following equations provide the design shear capacity of a PSW.

$$F'_s = (F_s) \quad x\left[\frac{1}{SF} \text{ or } \phi\right] \quad \text{(units plf)} \quad \text{Eq. 6.5-1a}$$

$$F_{psw} = (F'_s) \quad x[L] \quad \text{(units lb)} \quad \text{Eq. 6.5-1b}$$

where,

F_{psw} = the design shear capacity (lb) of the perforated shear wall.

F_s = the unfactored (ultimate) and unadjusted unit shear capacity (plf) for each facing of the wall construction.

F'_s = the factored and adjusted design unit shear capacity (plf) for the wall construction.

L = the length of the perforated shear wall, which is defined as the distance between the restrained ends of the wall line.

$1/SF$ = the safety factor adjustment for use with allowable stress design – 2.0 for wind and 2.5 for seismic design.

ϕ = the resistance factor adjustment for use with load and resistance factor design.

The PSW method (equations 6.5-1a and b) has the following limits on its use—

- The value of F_s for the wall construction should not exceed 1,500 plf in accordance with section 6.5.2.1. The wall must be fully sheathed with WSPs on at least one side. Unit shear values of sheathing materials may be combined in accordance with section 6.5.2.1.
- Full-height wall segments within a PSW should not exceed an aspect ratio of 4 (height/width) unless that portion of the wall is treated as an opening. (Some codes limit the aspect ratio to 2 or 3.5, but recent testing—mentioned earlier—has demonstrated otherwise.) The first wall segment on either end of a PSW must not exceed the aspect ratio limitation.
- The ends of the PSW must be restrained with hold-down devices sized in accordance with section 6.5.2.3. Hold-down forces that are transferred from the wall above are additive to the hold-down forces in the wall below. Alternatively, each wall stud may be restrained by using a strap sized to resist an uplift force equivalent to the design unit shear resistance F'_s of the wall.
- Top plates must be continuous, with a minimum connection capacity at splices with lap joints of 1,000 pounds (lb) or as required by the design condition, whichever is greater.
- Bottom plate connections that transfer shear to the construction below (that is, resist slip) should be designed in accordance with section 6.5.2.4 and should result in a connection at least equivalent to one 1/2-inch anchor bolt at 6 feet on center or two 16d pneumatic nails 0.131-inch diameter at 24 inches on center for wall constructions with F_s not exceeding 800 plf (ultimate capacity of interior and exterior sheathing). Such connections have been shown to provide an ultimate shear slip capacity of more than 800 plf in typical shear wall framing systems (NAHB, 1999); refer to section 7.3.6 of chapter 7.
- Net wind uplift forces from the roof and other tension forces that result from structural actions above the wall are transferred through the wall by using an independent load path. Wind uplift may be resisted with the previously described strapping option, provided that the straps are sized to transfer the additional load.

Segmented Shear Wall Design Approach

The following equations are used to determine the adjusted and factored shear capacity of a segmented shear wall (SSW):

$$F'_s = F_s \left[\frac{1}{SF} \text{ or } \phi \right] \quad \text{Eq. 6.5-2a}$$

$$F_{ssw} = F'_s \times [L_s] \quad \text{Eq. 6.5-2b}$$

where,

- F_{ssw} = the design shear capacity (lb) of a single shear wall segment.
- F_s = the unfactored (ultimate) and unadjusted unit shear resistance (plf) for the wall construction in accordance with section 6.5.2.1 for each facing of the wall construction.
- F'_s = the factored (design) and adjusted unit shear resistance (plf) for the total wall construction.
- L_s = the length of a shear wall segment (total width of the sheathing panel[s] in the segment).
- $1/SF$ = the safety factor adjustment for use with allowable stress design – 2.0 for wind and 2.5 for seismic design.
- ϕ = the resistance factor adjustment for use with load and resistance factor design.

The SSW design method (equations 6.5-2a and b) imposes the following limits.

- The aspect ratio of wall segments should not exceed 4 (height/width), as determined by the sheathing dimensions on the wall segment. (Absent an adjustment for the aspect ratio, current codes may restrict the segment aspect ratio to a maximum of 2 or 3.5.).
- The ends of the wall segment should be restrained in accordance with section 6.5.2.3. Hold-down forces that are transferred from shear wall segments in the wall above are additive to the hold-down forces in the wall below.
- Shear transfer at the base of the wall should be determined in accordance with section 6.5.2.4.
- Net wind uplift forces from the roof and other tension forces as a result of structural actions described are transferred through the wall using an independent load path.

For walls with multiple shear wall segments, the design shear resistance for the individual segments may be added to determine the total design shear resistance for the SSW line. Alternatively, the combined shear capacity at given amounts of drift may be determined by using the load-deformation equations in section 6.5.2.4.

6.5.2.3 Overturning Restraint

Section 6.3 and figure 6.5 address overturning restraint of shear walls in conceptual terms. In practice, the two generally recognized approaches to providing overturning restraint call for—

- The evaluation of equilibrium of forces on a *restrained* shear wall segment using principles of engineering mechanics.
- The evaluation of *unrestrained* shear walls considering nonuniform dead load distribution at the top of the wall, with restraint provided by various connections (sheathing, wall bottom plate, corner framing, and so forth).

The first method applies to restrained shear wall segments in both the PSW and SSW methods. The first segment on each end of a PSW is restrained in one direction of loading; therefore, the overturning forces on that segment are analyzed in the same manner as for a SSW. The second method is a valid and conceptually realistic method of analyzing the restraint of typical residential wall constructions, but it has not yet fully matured. Using basic mechanics, as shown in figure 6.8, the following equation for the chord tension and compression forces are determined by summing moments around the bottom compression or tension side of a restrained shear wall segment.

$$\Sigma M_C = 0$$

$$F'_s (d)(h) - T (x) - D_w \left(\frac{1}{2}d\right) - (w_D)(d)\left(\frac{1}{2}d\right) = 0$$

$$T = \left(\frac{d}{x}\right) \left(F'_s h - \frac{1}{2}D_w - \frac{1}{2}(w_D)(d)\right) + t \quad \text{Eq. 6.5-7a}$$

$$\Sigma M_T = 0$$

$$C = \left(\frac{d}{x}\right) \left(F'_s h + \frac{1}{2}D_w + \frac{1}{2}(w_D)(d)\right) + c \quad \text{Eq. 6.5-7b}$$

where,

- T = the tension force on the hold-down device (lb).
- d = the width of the restrained shear wall segment (ft); for segments greater than 4 ft in width, use d = 4 ft.
- x = the distance between the hold-down device and the compression edge of the restrained shear wall segment (ft); for segments greater than 4 ft in width, use x = 4 ft plus or minus the bracket offset dimension, if any.

- F'_s = the design unit shear capacity (plf) determined in accordance with equation 6.5-2a (for both the PSW and SSW methods).
- h = the height of the wall (ft).
- D_w = the dead load of the shear wall segment (lb); dead load must be factored and wind uplift considered in accordance with the load combinations of chapter 3.
- w_D = the uniform dead load supported by the shear wall segment (plf); dead load must be factored and wind uplift considered in accordance with the load combinations of chapter 3.
- t = the tension load transferred through a hold-down device, if any, restraining a wall above (lb); if no tension load exists, $t = 0$.
- c = the compression load transferred from wall segments above, if any (lb); this load may be distributed by horizontal structural elements above the wall (that is, not a concentrated load); if no compression load exists, $c = 0$.

The 4-ft width limit for d and x is imposed on the analysis of overturning forces as presented above because with longer shear wall lengths, the contribution of the additional dead load cannot be rigidly transferred through deep bending action of the wall to have a full effect on the uplift forces occurring at the end of the segment, particularly when it is rigidly restrained from uplifting. This effect also depends on the stiffness of the construction above the wall that “delivers” and distributes the load at the top of the wall. The assumptions necessary to include the restraining effects of dead load are no trivial matter and, for that reason, designers commonly do not include any beneficial effect of dead load in the overturning force analysis of individual shear wall segments.

FIGURE 6.8

Evaluation of Overturning Forces on a Restrained Shear Wall Segment

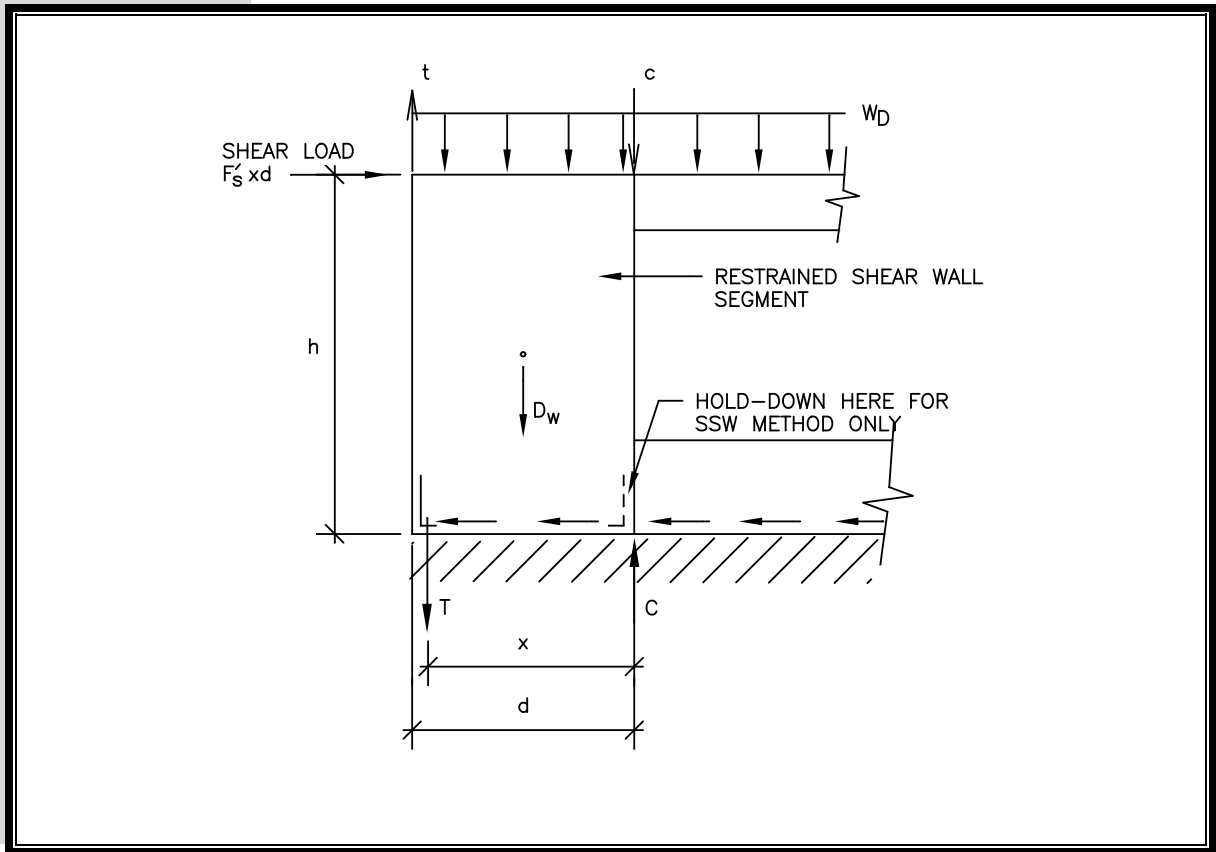

For a more simplified analysis of overturning forces, the effect of dead load may be neglected (the normal case in practice) and the chord forces determined as follows, using the symbols defined as before.

$$T = C = \left(\frac{d}{x}\right) F'_s h \quad \text{Eq. 6.5-7c}$$

Any tension or compression force transferred from shear wall overturning forces originating above the wall under consideration must be added to the result of equation 6.5-7c, as appropriate. Also, any net wind uplift force is assumed to be resisted by a separate load path (that is, wind uplift straps are used in addition to overturning or hold-down devices).

The proper detailing to balance localized stiffness effects for more even force transfer obviously is a matter of designer judgment. It is mentioned here to emphasize the importance of detailing in wood-framed construction. In particular, wood framing has the innate ability to distribute loads, although weaknesses can develop from seemingly insignificant details. The concern noted has been attributed to actual problems (that is, bottom plate splitting) only in severe seismic events and in relatively heavily loaded shear walls. For that reason, braced wall lines now require larger washers on bottom plate anchor bolts, such as a 3-inch

square by 1/4-inch thick plate washer, to prevent the development of cross-grain tension forces in bottom plates in high-hazard seismic regions. The development of high cross-grain tension stresses poses less concern when nails are used to fasten the bottom plate and are located in pairs or staggered on both sides of the wood plate; thus, the two connection options mentioned represent different approaches. The first, using the plate washers, maintains a rigid connection throughout the wall to prevent cross-grain tension in the bottom plate. The second, using nails, is a more “flexible” connection that prevents concentrated cross-grain bending forces from developing. With sufficient capacity provided, the nailing approach may yield a more “ductile” system.

Finally, the hold-down must be attached to a vertical wall framing member (that is, a stud) that receives the WSP edge nailing. If not, the hold-down will not be fully effective (that is, the overturning forces must be “delivered” to the hold-down through the sheathing panel edge nailing).

6.5.2.4 Shear Wall Stiffness and Drift

The methods described in this section for predicting shear wall stiffness or drift are based on idealized conditions representative solely of the testing conditions to which the equations are related. The conditions do not account for the many factors that may decrease the actual drift of a shear wall in its final construction. As mentioned, shear wall drift is generally overestimated in comparison with actual behavior in a completed structure (see section 6.2 on whole-building tests). The degree of overprediction may reach a factor of 2 at design load conditions. At capacity, the error may not be as large because some nonstructural components may be past their yield point.

At the same time, drift analysis may not consider the factors that also increase drift, such as deformation characteristics of the hold-down hardware (for hardware that is less stiff than that typically used in testing), lumber shrinkage (causing time-delayed slack in joints), lumber compression under heavy shear wall compression chord load, and construction tolerances. The results of a drift analysis should be considered as a guide to engineering judgment, therefore, not an exact prediction of drift.

The load-drift equations in this section may be solved to yield shear wall resistance for a given amount of shear wall drift. In this manner, a series of shear wall segments or even PSWs embedded within a given wall line may be combined to determine an overall load-drift relationship for the entire wall line. The load-drift relationships are based on the nonlinear behavior of wood-framed shear walls and provide a reasonably accurate means of determining the behavior of walls of various configurations. The relationships may also be used for determining the relative stiffness of shear wall lines in conjunction with the relative stiffness method of distributing lateral building loads, and the relationships may also be used for considering torsional behavior of a building with a nonsymmetrical shear wall layout in stiffness and in geometry. The approach is fairly straightforward and is left to the reader for experimentation.

Perforated Shear Wall Load-Drift Relationship

The load-drift equation that follows is based on several PSW tests already discussed in this chapter. The equation provides a nonlinear load-drift relationship up to the ultimate capacity of the perforated shear. When considering shear wall load-drift behavior in an actual building, the reader is reminded of the aforementioned accuracy issues; however, accuracy relative to the test data is reasonable (that is, plus or minus 1/2 inch at capacity).

$$\Delta = 1.8 \left(\frac{0.5}{G} \right) \left(\frac{1}{\sqrt{r}} \right) \left(\frac{V_d}{F_{PSW,ULT}} \right)^{2.8} \left[\frac{h}{8} \right] \text{ (inches)} \quad \text{Eq. 6.5-8}$$

where

- Δ = the shear wall drift (in) at shear load demand, V_d (lb).
- G = the specific gravity of framing lumber .
- r = the sheathing area ratio.
- V_d = the shear load demand (lb) on the perforated shear wall; the value of V_d is set at any unit shear demand less than or equal to $F_{psw,ult}$, whereas the value of V_d should be set to the design shear load when checking drift at design load conditions.
- $F_{psw,ult}$ = the unfactored (ultimate) shear capacity (lb) for the perforated shear wall (that is, $F_{psw} \times SF$ or F_{psw}/ϕ for ASD and LRFD, respectively).
- h = the height of wall (ft).

Segmented Shear Wall Load-Drift Relationship

APA Semiempirical Load-Drift Equation

Several codes and industry design guidelines specify a deflection equation for shear walls that includes a multipart estimate of various factors' contribution to shear wall deflection (APA, 2007; ICBO, 1997; ICC, 2012a). The approach relies on a mix of mechanics-based principles and empirical modifications. The principles and modifications are not repeated here because the APA method of drift prediction is considered no more reliable than that presented next. In addition, the equation is complex relative to the ability to predict drift accurately. It also requires adjustment factors, such as a nail-slip factor, that can only be determined by testing.

Empirical, Nonlinear Load-Drift Equation

Drift in a WSP shear wall segment may be approximated in accordance with the following equation—

$$\Delta = 2.2 \left(\frac{0.5}{G} \right)^{4/a} \left(\frac{V_d}{F_{SSW,ULT}} \right)^{2.8} \left[\frac{h}{8} \right] \quad (\text{in}) \quad \text{Eq. 6.5-9}$$

where,

- Δ = the shear wall drift (in) at load V_d (lb).
- G = the specific gravity of framing lumber.
- a = the shear wall segment aspect ratio (height/width) for aspect ratios from 4 to 1; a value of 1 shall be used for shear wall segments with width (length) greater than height.
- V_d = the shear load demand (lb) on the wall; the value of V_d is set at any unit shear demand less than or equal to $F_{SSW,ult}$, whereas the value of V_d should be set to the design load when checking drift at design load conditions.
- $F_{SSW,ult}$ = the unfactored (ultimate) shear capacity (lb) of the shear wall segment (that is, $F_{SSW} \times SF$ or F_{SSW}/ϕ for allowable stress design and load and resistance factor design, respectively).
- h = the height of wall (ft).

The preceding equation is based on several tests of shear wall segments with aspect ratios ranging from 4:1 to 1:5.

6.5.2.5 Portal Frames

In situations with little space to include sufficient shear walls to meet required loading conditions, the designer must turn to alternatives. An example is a garage opening supporting a two-story home on a narrow lot such that the presence of other wall openings for windows and an entrance door leaves little room for shear walls. One option is to consider torsion and the distribution of lateral loads in accordance with the relative stiffness method. Another possibility is the use of a portal frame.

Portal frames may be simple, specialized framing details that can be assembled on site. They use fastening details, metal connector hardware, and sheathing to form a wooden moment frame and, in many cases, perform adequately. Various configurations of portal frames have undergone testing and provide data and details on which the designer can base a design (APA, 2008; NAHB, 1998). The ultimate shear capacity of portal frames ranges from 2,400 to more than 6,000 pounds, depending on the complexity and strength of the construction details. A simple detail involves extending a garage header so that it is end-nailed to a full-height corner stud, strapping the header to the jamb studs at the portal opening, attaching sheathing with a standard nailing schedule, and anchoring the portal frame with typical PSW requirements. The system has an ultimate shear capacity of about 3,400 pounds that, with a safety factor of 2 to 2.5, provides a simple solution for many portal frame applications for residential construction in high-hazard seismic or wind regions. Several manufacturers offer

pre-engineered portal frame and shear wall elements that can be ordered to custom requirements or standard conditions.

6.5.2.6 Moment Frames

Some designs and floor and wall layouts create large open spaces, where achieving sufficient lateral load resistance is very difficult with an ordinary LFRS system, including portal frames. An example of such an opening is illustrated in figure 6.9. This house is located in a hurricane-prone region, where wind speeds could be extreme. The front wall is all openings and is relatively narrow, yet winds that impact either side of the house will push the house right or left with little restraint provided by the front wall. The moment frame in the example is steel, which will resist the lateral loads of the wind with minimal deflection.

The designer must analyze the moment frame as a two-dimensional frame, determine the stresses in the members and the connections, and predict the tension force that can occur at the moment frame connection to the framing platform. This analysis then provides sufficient information to design the steel members and specify the connections. Most frames like the one shown in figure 6.9 are shop fabricated and field erected. They use steel sections that will fit within the confines of wood framing, thus the steel sections will be I- or W-beam shapes or rectangular or square steel tubing to which wood framing can easily be attached.

Proprietary moment frames are available that are specified based on loads to be resisted and the span and height of the opening. Many of those frames are bolted together in the field, but they also are available ready to attach wood framing.

FIGURE 6.9

Moment Frame



Note: Photo courtesy FEMA 55 Coastal Construction Manual.

6.5.3 Diaphragm Design

6.5.3.1 Diaphragm Design Values

Depending on the location and number of supporting shear wall lines, the shear and moments on a diaphragm are determined by using the analogy of a simply supported or continuous span beam. The designer uses the shear load on the diaphragm per unit width of the diaphragm (that is, floor or roof) to select a combination of sheathing and fastening from a table of allowable horizontal diaphragm unit shear values; such tables may be found in U.S. building codes or engineering standards. Similar to those for shear walls, unit shear values for diaphragms vary according to sheathing thickness and nailing schedules, among other factors. Table 6.4 presents several of the more common floor and roof constructions used in residential construction, as well as their allowable diaphragm resistance values. The values include a safety factor for allowable

stress design and therefore require no additional factoring. The aspect ratio of a diaphragm should be no greater than 4 (length/width), in accordance with current building code limits. In addition, the sheathing attachment in floor diaphragms often is supplemented with glue or construction adhesive. The increase in unit shear capacity of vertical diaphragms (that is, shear walls) was discussed in section 6.5.2.1 in association with table 6.1.

TABLE 6.4

Horizontal Diaphragm Maximum Nominal Shear Values (plf) for Unblocked Roof and Floor Construction Using Douglas-Fir Framing^{a, b, c}

Panel Type and Application	Nominal Panel Thickness (inches)	Common Nail Size	Design Shear Value (plf)
Structural I (roof)	5/16	6d	460
	3/8	8d	670
	15/32	10d	800
APA Sturd-I-Floor (floor) and rated sheathing	7/16	8d	645
	15/32	8d	670
	19/32	10d	800

plf = pounds per linear foot.

^a Minimum framing member thickness is 1 1/2 inches.

^b Nails are spaced at 6 inches on center at supported panel edges and at the perimeter of the diaphragm. Nails spaced at 12 inches on center on other framing members are spaced a maximum of 24 inches on center.

^c “Unblocked” means that sheathing joints perpendicular to framing members are not fastened to blocking.

Source: AWC NDS Wind and Seismic Supplement 2008

6.5.3.2 Diaphragm Design

As noted, diaphragms are designed in accordance with simple beam equations. To determine the shear load on a simply supported diaphragm (that is, a diaphragm supported by shear walls at each side), the designer uses the following equation to calculate the unit shear force to be resisted by the diaphragm sheathing.

$$V_{\max} = \frac{1}{2} wl \quad \text{Eq. 6.5-10a}$$

$$v_{\max} = \frac{V_{\max}}{d} \quad \text{Eq. 6.5-10b}$$

where,

V_{\max} = the maximum shear load on the diaphragm (plf).

w = the tributary uniform load (plf) applied to the diaphragm, resulting from seismic or wind loading.

l = the length of the diaphragm perpendicular to the direction of the load (ft).

v_{\max} = the unit shear across the diaphragm in the direction of the load (plf).

d = the depth or width of the diaphragm in the direction of the load (ft).

The following equations are used to determine the theoretical chord tension and compression forces on a simply supported diaphragm, as described previously.

$$M_{\max} = \frac{1}{8} wl^2 \quad \text{Eq. 6.5-11a}$$

$$T_{\max} = C_{\max} = \frac{M_{\max}}{d} \quad \text{Eq. 6.5-11b}$$

where,

M_{\max} = the bending moment on the diaphragm (ft-lb).

w = the tributary uniform load (plf) applied to the diaphragm, resulting from seismic or wind loading.

l = the length of the diaphragm perpendicular to the direction of the load (ft).

T_{\max} = the maximum chord tension force (lb).

C_{\max} = the maximum chord compression force (lb).

d = the depth or width of the diaphragm in the direction of the load (ft).

If the diaphragm is not simply supported at its ends, the designer uses appropriate beam equations (see appendix A) in a manner similar to the preceding equation to determine the shear and moment on the diaphragm. The calculations to determine the unit shear in the diaphragm and the tension and compression in the chords also are similar to those given. The designer should note that the maximum chord forces occur at the location of the maximum moment. For a simply supported diaphragm, the maximum chord forces occur at mid-span, between the perimeter shear walls. Thus, chord requirements may vary depending on location and magnitude of the bending moment on the diaphragm. Similarly, shear forces on a simply supported diaphragm are highest near the perimeter shear walls (that is, reactions). Nailing requirements for diaphragms may therefore be adjusted depending on the variation of the shear force in interior regions of the diaphragm. Generally, those variations are not critical in small residential structures such that fastening schedules can remain constant throughout the entire diaphragm. If the horizontal diaphragm contains openings, the width of the opening dimension usually is discounted from the width d of the diaphragm when determining the unit shear load on the diaphragm.

6.5.3.3 Shear Transfer (Sliding)

The shear forces in the diaphragm must be adequately transferred to the supporting shear walls. For typical residential roof diaphragms, conventional roof framing connections often are sufficient to transfer the small sliding shear forces to the shear walls (unless heavy roof coverings are used in high-hazard seismic areas, or steep roof slopes are used in high-hazard wind regions). The transfer of

shear forces from floor diaphragms to shear walls may also be handled by conventional nailed connections between the floor boundary member (that is, a band joist or end joist that is attached to the floor diaphragm sheathing) and the wall framing below. In heavily loaded conditions, metal shear plates may supplement the connections. The simple rule to follow for those connections is that the shear force in from the diaphragm must equal the shear force out to the supporting wall. Floors supported on a foundation wall usually are connected to a wood sill plate bolted to the foundation wall; however, the floor joist or the band joist may be directly connected to the foundation wall. Chapter 7 addresses the design of these shear connections.

6.5.3.4 Diaphragm Stiffness

Diaphragm stiffness may be calculated using semiempirical methods based on principles of mechanics. The equations are found in most modern building codes and industry guidelines (APA, 2007; ICC, 2012a). For typical residential construction, however, the calculation of diaphragm deflection is almost never necessary and is rarely performed; therefore, the equations and their empirical adjustment factors are not repeated here. Nonetheless, the designer who attempts diaphragm deflection or stiffness calculations is cautioned regarding the same accuracy concerns mentioned for shear wall drift calculations. The stiffness of floor and roof diaphragms is highly dependent on the final construction, including interior finishes (see section 6.2 on whole-building tests).

6.6 Design Examples

EXAMPLE 6.1

Segmented Shear Wall Design

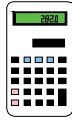

Given

The segmented shear wall line, as shown in the figure below, has the following dimensions:

$$h = 8 \text{ ft}$$

$$L_1 = 3 \text{ ft}$$

$$L_2 = 2 \text{ ft}$$

$$L_3 = 8 \text{ ft}$$

Window is 3 ft wide

Wall construction:

- Exterior sheathing is 7/16-inch thick OSB with 8d pneumatic nails (0.113-inch diameter by 2.375 inches long) spaced 6 inches on center on panel edges and 12 inches on center in panel field.
- Interior sheathing is 1/2-inch thick gypsum wall board with #6 screws at 12 inches on center.
- Framing lumber is Spruce-Pine-Fir, stud grade (specific gravity, $G = 0.42$); studs are spaced at 16 inches on center.

Loading condition (assumed for illustration)

$$\text{Wind shear load on wall line} = 3,000 \text{ lb}$$

$$\text{Seismic shear load on wall line} = 1,000 \text{ lb}$$

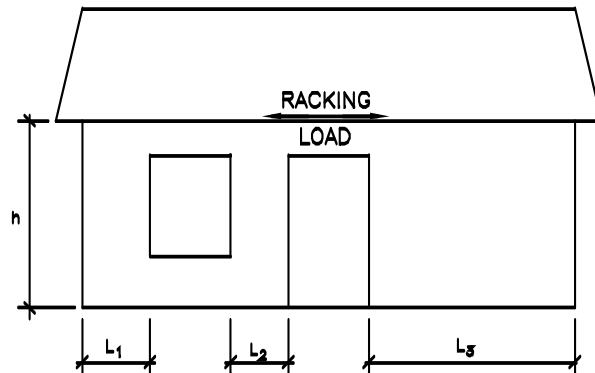

Find

1. Design capacity of the segmented shear wall line for wind and seismic shear resistance.
2. Base shear connection requirements.
3. Chord tension and compression forces.
4. Load-drift behavior of the segmented shear wall line and estimated drift at design.

Solution

- Determine the adjusted (design) shear capacities for the wall segments and the total wall line (section 6.5.2).

$$\begin{aligned}
 F_{s,ext} &= 715 \text{ plf wind} && \text{OSB sheathing (table 6.1 – OSB is Structural I)} \\
 F_{s,ext} &= 510 \text{ plf seismic} && \text{OSB sheathing (table 6.1)} \\
 F_{s,int} &= 80 \text{ plf} && \text{GWB sheathing (table 6.3)}
 \end{aligned}$$

The design shear capacity of the wall construction is determined as follows for each segment (sections 6.5.2.1 and 6.5.2.2):

$$\begin{aligned}
 F'_s &= F'_{s,ext} + F'_{s,int} \\
 F'_s &= F_{s,ext} [1/SF] + F_{s,int} [1/SF] \\
 SF &= 2.0 \text{ (wind) or } 2.5 \text{ (seismic)}
 \end{aligned}$$

Segment 1

$$a = h/L_1 = (8 \text{ ft})/(3 \text{ ft}) = 2.67 \quad (\text{segment aspect ratio})$$

For wind design

$$\begin{aligned}
 F'_{s,1,wind} &= (715 \text{ plf})(1/2.0) + (80 \text{ plf})(1/2.0) \\
 &= 358 \text{ plf} + 40 \text{ plf} = 398 \text{ plf} \\
 F_{ssw,1,wind} &= F'_s(L_1) = (398 \text{ plf})(3 \text{ ft}) = 1194 \text{ lb}
 \end{aligned}$$

For seismic design

$$\begin{aligned}
 F'_{s,1,seismic} &= (510 \text{ plf})(1/2.5) + 0 = 204 \text{ plf} \\
 F_{ssw,1,seismic} &= (204 \text{ plf})(3 \text{ ft}) = 612 \text{ lb}
 \end{aligned}$$

Segment 2

For wind design

$$\begin{aligned}
 F'_{s,2,wind} &= (715 \text{ plf})(1/2.0) + (80 \text{ plf})(1/2.0) \\
 &= 358 \text{ plf} + 40 \text{ plf} = 398 \text{ plf} \\
 F_{ssw,2,wind} &= (398 \text{ plf})(2 \text{ ft}) = 796 \text{ lb}
 \end{aligned}$$

For seismic design

$$\begin{aligned}
 F'_{s,2,seismic} &= (510 \text{ plf})(1/2.5) + 0 = 204 \text{ plf} \\
 F_{ssw,2,seismic} &= (204 \text{ plf})(2 \text{ ft}) = 408 \text{ lb}
 \end{aligned}$$

Segment 3

For wind design

$$\begin{aligned}
 F'_{s,3,wind} &= (715 \text{ plf})(1/2.0) + (80 \text{ plf})(1/2.0) \\
 &= 358 \text{ plf} + 40 \text{ plf} = 398 \text{ plf} \\
 F_{ssw,3,wind} &= (398 \text{ plf})(8 \text{ ft}) = 3184 \text{ lb}
 \end{aligned}$$

For seismic design

$$\begin{aligned}F'_{s,3,seismic} &= (510 \text{ plf})(1/2.5) + 0 = 204 \text{ plf} \\F_{ssw,3,seismic} &= (204 \text{ plf})(8 \text{ ft}) = 1632 \text{ lb}\end{aligned}$$

Total for wall line

$$\begin{aligned}F_{ssw,total,wind} &= 1194 \text{ lb} + 796 \text{ lb} + 3184 \text{ lb} = 5174 \text{ lb} \\F_{ssw,total,seismic} &= 612 \text{ lb} + 408 \text{ lb} + 1632 \text{ lb} = 2652 \text{ lb}\end{aligned}$$

2. Determine base shear connection requirements to transfer shear load to the foundation or floor construction below the wall.

The wall bottom plate to the left of the door opening is considered to be continuous and therefore acts as a distributor of the shear load resisted by segments 1 and 2. The uniform shear connection load on the bottom plate to the left of the opening is determined as follows—

$$\text{Bottom plate length} = 3 \text{ ft} + 3 \text{ ft} + 2 \text{ ft} = 8 \text{ ft}$$

$$\begin{aligned}\text{Base shear resistance required (wind)} &= (F_{ssw,1,wind} + F_{ssw,2,wind})/(\text{plate length}) \\&= (1194 \text{ lb} + 796 \text{ lb})/(8 \text{ ft}) = 249 \text{ plf}\end{aligned}$$

$$\begin{aligned}\text{Base shear resistance required (seismic)} &= (F_{ssw,1,seismic} + F_{ssw,2,seismic})/(\text{plate length}) \\&= (612 \text{ lb} + 408 \text{ lb})/(8 \text{ ft}) = 128 \text{ plf}\end{aligned}$$

For the wall bottom plate to the right of the door opening, the base shear connection is equivalent to $F'_{s,3,wind} = 398 \text{ plf}$ or $F'_{s,3,seismic} = 204 \text{ plf}$ for wind and seismic design respectively.

Normally, this connection is achieved by use of nailed or bolted bottom plate fastenings. Refer to chapter 7 and section 7.3.6 for information on designing these connections.

Notes:

1. Although the preceding example shows that variable bottom plate connections may be specified based on differing shear transfer requirements for portions of the wall, using a constant (that is, worst case) base shear connection to simplify construction is acceptable practice; however, doing so can result in excessive fastening requirements for certain loading conditions and shear wall configurations.
2. For the assumed wind loading of 3,000 lb, the wall has excess design capacity (that is, 5174 lb). The design wind load may be distributed to the shear wall segments in proportion to their design capacity (as shown in the next step for hold-down design) to reduce the shear connection loads accordingly. For seismic design, this should not be done, and the base shear connection design should be based on the design capacity of the shear walls to ensure that a “balanced design” is achieved (that is, the base connection capacity meets or exceeds that of the shear wall). That approach is necessary in seismic design because the actual shear force realized in the connections may be substantially higher than those anticipated by the design seismic load calculated using an R factor in accordance with equation 3.8-1 of chapter 3. Refer also to the discussion on R factors and overstrength in section 3.8.2 of chapter 3. The designer should realize that the GWB interior finish design shear capacity was

not included in determining the design shear wall capacity for seismic loading. Although this is representative of current building code practice, it can create a situation in which the actual shear wall capacity and connection forces experienced are higher than those used for design purposes. This condition (that is, underestimating of the design shear wall capacity) should also be considered in providing sufficiently strong overturning connections (that is, hold-downs), as covered in the next step.

3. Determine the chord tension and compression (that is, overturning) forces in the shear wall segments (section 6.5.2.3).

Basic equation for overturning (equation 6.5-7c)—

$$T = C = (d/x)(F'_s)(h)$$

Segment 1

$$h = 8 \text{ ft}$$

$$d = 3 \text{ ft}$$

$$x = d - (\text{width of end studs} + \text{offset to center of hold-down anchor bolt})^* \\ = 3 \text{ ft} - (4.5 \text{ in} + 1.5 \text{ in})(1 \text{ ft}/12 \text{ in}) = 2.5 \text{ ft}$$

*If an anchor strap is used, the offset dimension may be reduced from that determined here, assuming a side-mounted hold-down bracket. Also, depending on the number of studs at the end of the wall segment and the type of bracket used, the offset dimension will vary and must be verified by the designer.

$$F'_{s,1,\text{wind}} = 398 \text{ plf}$$

$$F'_{s,1,\text{seismic}} = 204 \text{ plf}$$

$$T = C = (3 \text{ ft} / 2.5 \text{ ft})(398 \text{ plf})(8 \text{ ft}) = 3821 \text{ lb(wind)}$$

$$T = C = (3 \text{ ft} / 2.5 \text{ ft})(204 \text{ plf})(8 \text{ ft}) = 1958 \text{ lb(seismic)}$$

Segment 2

$$h = 8 \text{ ft}$$

$$d = 2 \text{ ft}$$

$$x = 2 \text{ ft} - 0.5 \text{ ft} = 1.5 \text{ ft}$$

$$F'_{s,2,\text{wind}} = 398 \text{ plf}$$

$$F'_{s,2,\text{seismic}} = 204 \text{ plf}$$

$$T = C = (2 \text{ ft} / 1.5 \text{ ft})(398 \text{ plf})(8 \text{ ft}) = 4245 \text{ lb(wind)}$$

$$T = C = (2 \text{ ft} / 1.5 \text{ ft})(204 \text{ plf})(8 \text{ ft}) = 2176 \text{ lb(seismic)}$$

Segment 3

$$h = 8 \text{ ft}$$

$$d = 8 \text{ ft}$$

$$x = 8 \text{ ft} - 0.5 \text{ ft} = 7.5 \text{ ft}$$

$$F'_{s,2,\text{wind}} = 398 \text{ plf}$$

$$F'_{s,2,\text{seismic}} = 204 \text{ plf}$$

$$T = C = (8 \text{ ft} / 7.5 \text{ ft})(398 \text{ plf})(8 \text{ ft}) = 3396 \text{ lb(wind)}$$

$$T = C = (8 \text{ ft} / 7.5 \text{ ft})(204 \text{ plf})(8 \text{ ft}) = 1741 \text{ lb(seismic)}$$

Notes:

1. In each of the preceding cases, the seismic tension and compression forces on the shear wall chords are less than that determined for the wind loading condition. This occurrence is the result of using a larger safety factor to determine the shear wall design capacity and the practice of not including the interior sheathing (GWB) design shear capacity for seismic design. Thus, the chord forces based on the seismic shear wall design capacity may be underdesigned unless a sufficient safety factor is used in the manufacturer's rated hold-down capacity to compensate. In other words, the ultimate capacity of the hold-down connector should be greater than the overturning force that could be created based on the ultimate shear capacity of the wall, including the contribution of the interior GWB finish. The designer should verify this condition because the current code practice may not provide explicit guidance on the issue of balanced design on the basis of system capacity (that is, connector capacity relative to shear wall capacity). This issue is primarily a concern with seismic design because of the higher safety factor used to determine design shear wall capacity and the code practice not to include the contributing shear capacity of the interior finish.
2. The designer should recognize that the compression chord force is not a point load at the top of the stud(s) comprising the compression chord. Rather, the compression chord force accumulates through the sheathing, beginning at the top of the wall with a value of zero and increasing to C (as determined previously) at the base of the compression chord. This condition will affect how the compression chord is modeled from the standpoint of determining its capacity as a column, using the column equations in the NDS.
3. The design of base shear connections and overturning forces assume that the wind uplift forces at the base of the wall are offset by 0.6 times the dead load (ASD) at that point in the load path or that an additional load path for uplift is provided by metal strapping or other means.
4. As mentioned in step 2 for the design of base shear connections, the wind load on the designated shear wall segments may be distributed according to the design capacity of each segment in proportion to that of the total shear wall line. This method is particularly useful when the design shear capacity of the wall line is substantially higher than the shear demand required by the wind load, as is applicable to this hypothetical example. Alternatively, a shear wall segment may be eliminated from the analysis by not specifying restraining devices for the segment (that is, hold-down brackets). If the former approach is taken, the wind load is distributed as follows:

Fraction of design wind load to segment 1:

$$F_{ssw,1,wind} / F_{ssw,total,wind} = (1194 \text{ lb}) / (5174 \text{ lb}) = 0.23$$

Fraction of wind load to segment 2:

$$F_{ssw,2,wind} / F_{ssw,total,wind} = (796 \text{ lb}) / (5174 \text{ lb}) = 0.15$$

Fraction of wind load to segment 3:

$$F_{ssw,3,wind} / F_{ssw,total,wind} = (3184 \text{ lb}) / (5174 \text{ lb}) = 0.62$$

Thus, the unit shear load on each shear wall segment resulting from the design wind shear of 3,000 lb on the total wall line is determined as follows—

Segment 1:	$0.23(3,000 \text{ lb}) / (3 \text{ ft}) = 230 \text{ plf}$
Segment 2:	$0.15(3,000 \text{ lb}) / (2 \text{ ft}) = 225 \text{ plf}$
Segment 3:	$0.62(3,000 \text{ lb}) / (8 \text{ ft}) = 233 \text{ plf}$

The overturning forces (chord forces) determined above and the base shear connection requirements determined in step 2 may be recalculated by substituting the preceding values, which are based on the design wind loading. This approach only applies to the wind loading condition when the design wind loading on the wall line is less than the design capacity of the wall line. As mentioned, eliminating a designed shear wall segment to bring the total design shear capacity more in line with the design wind shear load on the wall may be more efficient. Alternatively, a lower capacity shear wall construction may be specified to better match the loading condition (such as a design using a thinner wood structural sheathing panel). This decision will depend on the conditions experienced in other walls of the building such that a single wall construction type may be used throughout for all exterior walls (that is, simplified construction).

4. Determine the load-drift behavior of the wall line.

Only the load-drift behavior for wind design is shown here. For seismic design, a simple substitution of the design shear capacities of the wall segments and the safety factor for seismic design (as determined previously) may be used to determine a load-drift relationship for use in seismic design.

The basic equation for load-drift estimation of a shear wall segment is as follows—

$$\Delta = 2.2 \left(\frac{0.5}{G} \right) \sqrt[4]{a \left(\frac{V_d}{F_{SSW,ULT}} \right)^{2.8}} \left(\frac{h}{8} \right) \quad (\text{equation 6.5-9})$$

$$\begin{aligned} h &= 8 \text{ ft} \\ G &= 0.42 \text{ (Spruce-Pine-Fir)} \end{aligned}$$

Aspect ratios for the wall segments—

$$\begin{aligned} a_1 &= 2.67 \\ a_2 &= 4.0 \\ a_3 &= 1.0 \end{aligned}$$

$$\begin{aligned} F_{ssw,ult,1,wind} &= F_{ssw,1,wind} (SF) = (1196 \text{ lb})(2.0) = 2392 \text{ lb} \\ F_{ssw,ult,2,wind} &= F_{ssw,2,wind} (SF) = (796 \text{ lb})(2.0) = 1592 \text{ lb} \\ F_{ssw,ult,3,wind} &= F_{ssw,3,wind} (SF) = (3184 \text{ lb})(2.0) = 6368 \text{ lb} \end{aligned}$$

...therefore, the total ultimate capacity of the wall for wind loading is

$$F_{ssw,ult,wall,wind} = 2392 \text{ lb} + 1592 \text{ lb} + 6368 \text{ lb} = 10,352 \text{ lb}$$

Substituting the preceding values into the basic load-drift equation yields the following load-drift equations for each segment.

$$\begin{aligned} \text{Segment 1:} \quad \Delta_1 &= 1.03 \times 10^{-10} (V_{d,1,wind})^{2.8} \quad (\text{inches}) \\ \text{Segment 2:} \quad \Delta_2 &= 2.92 \times 10^{-10} (V_{d,2,wind})^{2.8} \quad (\text{inches}) \\ \text{Segment 3:} \quad \Delta_3 &= 8.46 \times 10^{-12} (V_{d,3,wind})^{2.8} \quad (\text{inches}) \end{aligned}$$

Because each segment must deflect equally (or nearly so) as the wall line deflects, the above deflections may be set equivalent to the total wall line drift, as follows—

$$\Delta_{\text{wall}} = \Delta_1 = \Delta_2 = \Delta_3$$

Further, the preceding equations may be solved for V_d as follows—

$$\text{Segment 1: } V_{d,1,\text{wind}} = 3683 (\Delta_{\text{wall}})^{0.36}$$

$$\text{Segment 2: } V_{d,2,\text{wind}} = 2541 (\Delta_{\text{wall}})^{0.36}$$

$$\text{Segment 3: } V_{d,3,\text{wind}} = 9003 (\Delta_{\text{wall}})^{0.36}$$

The sum of the preceding equations must equal the wind shear load (demand) on the wall at any given drift of the wall, as follows—

$$V_{d,\text{wall},\text{wind}} = V_{d,1,\text{wind}} + V_{d,2,\text{wind}} + V_{d,3,\text{wind}} = 15,227 (\Delta_{\text{wall}})^{0.36}$$

Solving for Δ_{wall} , the following final equation is obtained for estimating drift and any given wind shear load from zero to $F_{\text{ssw,ult,wall,wind}}$.

$$\Delta_{\text{wall}} = 4.04 \times 10^{-10} (V_{d,\text{wall},\text{wind}})^{2.8}$$

For the design wind load on the wall of 3,000 lb, as assumed in this example, the wall drift is determined as follows—

$$\Delta_{\text{wall}} = 4.04 \times 10^{-10} (3,000)^{2.8} = 2.2 \text{ inches}$$

Note: This analysis, as with most other methods of determining drift, may overlook many factors in the as-built construction that serve to increase or decrease drift. As discussed in section 6.2, whole-building tests seem to confirm that drift is generally overpredicted.

Conclusion In this example, the determination of the design shear capacity of a segmented shear wall was presented for seismic design and wind design applications. Issues related to connection design for base shear transfer and overturning forces (chord tension and compression) were also discussed, and calculations were made to estimate these forces using a conventional design approach. In particular, issues related to capacity-based design and “balanced design” of connections were discussed. Finally, a method to determine the load-drift behavior of a segmented shear wall line was presented. The final design may vary based on designer decisions and judgments (as well as local code requirements) related to the considerations and calculations as given in this example.

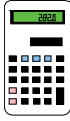
EXAMPLE 6.2**Perforated Shear Wall Design****Given**

The perforated shear wall, as shown in the following figure, is essentially the same wall used in example 6.1. The following dimensions are used—

$$\begin{aligned} h &= 8 \text{ ft} \\ L_1 &= 3 \text{ ft} \\ L_2 &= 2 \text{ ft} \\ L_3 &= 8 \text{ ft} \\ L &= 19 \text{ ft} \\ A_1 &= 3.2 \text{ ft} \times 5.2 \text{ ft} = 16.6 \text{ sf} \text{ (rough window opening area)} \\ A_2 &= 3.2 \text{ ft} \times 6.8 \text{ ft} = 21.8 \text{ sf} \text{ (rough door opening area)} \end{aligned}$$

Wall construction—

- Exterior sheathing is 7/16-inch thick OSB with 8d pneumatic nails (0.113 inch diameter by 2 3/8 inches long) spaced 6 inches on center on panel edges and 12 inches on center in panel field.
- Interior sheathing is 1/2-inch thick gypsum wall board with #6 screws at 12 inches on center.
- Framing lumber is Spruce-Pine-Fir, stud grade (specific gravity, $G = 0.42$); studs are spaced at 16 inches on center.

Loading condition (assumed for illustration):

Wind shear load on wall line = 3,000 lb

Seismic shear load on wall line = 1,000 lb

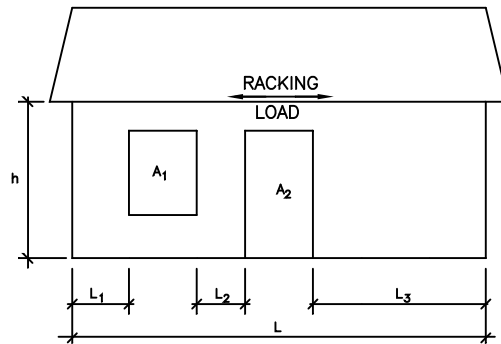
**Find**

1. Design capacity of the perforated shear wall line for wind and seismic shear resistance.
2. Base shear connection requirements.
3. Chord tension and compression forces.
4. Load-drift behavior of the perforated shear wall line and estimated drift at design load conditions.

Solution

1. Determine the adjusted (design) shear capacity for the perforated shear wall line.

$$F'_s = F_s [1/SF] \quad (\text{Eq. 6.5-1a})$$

$$SF = 2.0 \text{ (wind design) or } 2.5 \text{ (seismic design)}$$

$$F_s = F_{s,ext} + F_{s,int} \quad (\text{section 6.5.2.1})$$

$$F_{s,ext} = 715 \text{ plf} \quad (\text{table 6.1})$$

$$F_{s,int} = \mathbf{80 \text{ plf}} \quad (\text{table 6.3})$$

For wind design—

$$F_{s,wind} = 715 \text{ plf} + 80 \text{ plf} = 795 \text{ plf}$$

$$F'_{s,wind} = (795 \text{ plf})(1/2.0) = 398 \text{ plf}$$

For seismic design—

$$F_{s,seismic} = 510 \text{ plf} + 0 \text{ plf} = 510 \text{ plf}$$

$$F'_{s,seismic} = (510 \text{ plf})(1/2.5) = 204 \text{ plf}$$

The design capacity of the perforated shear wall is now determined as follows—

$$F_{psw} = F'_s L \quad (\text{Eq. 6.5-1b})$$

Assume for the sake of this example that the roof dead load supported at the top of the wall is 225 plf and that the design wind uplift force on the top of the wall is $0.6(225 \text{ plf}) - 400 \text{ plf} = -265 \text{ plf}$ (net design uplift). Thus, for wind design in this case, no dead load can be considered on the wall.

$$w_D = 0.6*(225 \text{ plf}) = 135 \text{ plf}$$

*The 0.6 factor comes from the load combinations $0.6D + (W \text{ or } 0.7E)$ or $0.6D - W_u$ as given in chapter 3.

For wind design,

$$F_{psw,wind} = (398 \text{ plf})(19 \text{ ft}) = 7562 \text{ lb}$$

For seismic design,

$$F_{psw,seismic} = (204 \text{ plf})(19 \text{ ft}) = 3876 \text{ lb}$$

Note: In example 6.1, using the segmented shear wall approach, the design shear capacity of the wall line was estimated as 5174 lb (wind) and 2652 lb (seismic) when all of the segments were restrained against overturning by use of hold-down devices. Given that the design shear load on the wall is 3,000 lb (wind) and 1,000 lb (seismic), however, the perforated shear wall design capacity as determined above is adequate, and significantly higher than that of the segmented shear wall. Hold-downs are therefore required only at the wall ends (see step 3).

2. Determine the base shear connection requirement for the perforated shear wall.

If the wall has a continuous bottom plate that serves as a distributor of the shear forces resisted by various portions of the wall, the base shear connection could be based on the perforated shear wall's design capacity as determined in step 1, as follows—

For wind design,

$$\text{UNIFORM BASE SHEAR} = (7562 \text{ LB})/19 \text{ FT} = 398 \text{ PLF}$$

For seismic design,

$$\text{UNIFORM BASE SHEAR} = (3876 \text{ LB})/19 \text{ FT} = 204 \text{ PLF}$$

The wall bottom plate is not continuous in this example, however; therefore, the base shears experienced by the portions of the wall to the left and right of the door opening are different, as was the case in the segmented shear wall design approach of example 6.1. As a conservative solution, the base shear connection could be designed to resist the design unit shear capacity of the wall construction, $F'_{s,\text{wind}} = 398 \text{ plf}$ or $F'_{s,\text{seismic}} = 204 \text{ plf}$. Newer codes that recognize the perforated shear method may require this more conservative approach to be used when the bottom plate is not continuous such that it serves as a distributor (that is, similar in function to a shear wall collector except shear transfer is out of the wall instead of into the wall). Of course, the bottom plate must be continuous, and any splices must be adequately detailed in a fashion similar to collectors (see example 6.3).

Testing has shown that for walls constructed similar to the one illustrated in this example, a bottom plate connection of two 16d pneumatic nails (0.131-inch diameter by 3 inches long) at 16 inches on center or 5/8-inch diameter anchor bolts at 6 feet on center provides suitable shear and uplift resistance—at least equivalent to the capacity of the shear wall construction under conditions of no dead load or wind uplift (NAHB, 1999). For other conditions, that connection must be designed following the procedures given in chapter 7, using the conservative assumptions as stated above.

As an alternative base connection that eliminates the need for hold-down brackets at the ends of the perforated shear wall, straps can be fastened to the individual studs to resist the required uplift force of 398 plf, as applicable to this example. If the studs are spaced 16 inches on center, the design capacity of the strap must be $(398 \text{ plf})(1.33 \text{ ft/stud}) = 529 \text{ lb}$ per stud. If an uplift load due to wind uplift on the roof must also be transferred through these straps, the strap design capacity must be increased accordingly. In this example, the net wind uplift at the top of the wall was assumed to be 265 plf. At the base of the wall, the uplift is $265 \text{ plf} - 0.6(8 \text{ ft})(8 \text{ psf}) = 227 \text{ plf}$. Thus, the total design uplift restraint must provide $398 \text{ plf} + 227 \text{ plf} = 625 \text{ plf}$. On a per-stud basis (16 inch on center framing), the design load is $1.33 \text{ ft/stud} \times 625 \text{ plf} = 831 \text{ lb/stud}$. That value must be increased for studs adjacent to wall openings, where the wind uplift force is increased, and can be achieved by using multiple straps or by specifying a larger strap in those locations. Of course, the above combination of uplift loads assumes that the design wind uplift load on the roof occurs simultaneously with the design shear load on the wall; however, this condition is usually not representative of actual conditions, depending on wind orientation, building configuration, and the shear wall location relative to the uplift load paths.

3. Determine the chord tension and compression forces.

Left end of the wall (segment 1 in example 6.1)—

$$\begin{aligned} T &= 3821 \text{ lb} && \text{(wind design)} \\ T &= 1958 \text{ lb} && \text{(seismic design)} \end{aligned}$$

Right end of the wall (segment 3 in example 6.1)—

$$T = 3396 \text{ lb} \quad (\text{wind design})$$

$$T = 1741 \text{ lb} \quad (\text{seismic design})$$

Note: One tension bracket (hold-down) is required at each the end of the perforated shear wall line but not on the interior segments. Also, refer to the notes in example 6.1 regarding “balanced design” of overturning connections and base shear connections, particularly when designing for seismic loads.

4. Determine the load-drift behavior of the perforated shear wall line.

The basic equation for load-drift estimation of a perforated shear wall line is as follows (section 6.5.2.6)—

$$\Delta = 1.8 \left(\frac{0.5}{G} \right) \left(\frac{1}{\sqrt{r}} \right) \left(\frac{V_d}{F_{PSW,ULT}} \right)^{2.8} \left(\frac{h}{8} \right) \quad (\text{Eq. 6.5-8})$$

$$h = 8 \text{ ft}$$

$$G = 0.42 \quad (\text{specific gravity for Spruce-Pine-Fir})$$

$$r = 1/(1+\alpha/\beta)$$

$$\alpha = \Sigma A_o / (h \times L) = (A_1 + A_2) / (h \times L)$$

$$= (16.6 \text{ sf} + 21.8 \text{ sf}) / (8 \text{ ft})(19 \text{ ft}) = 0.25$$

$$\beta = \Sigma L_i / L = (L_1 + L_2 + L_3) / L$$

$$= (3 \text{ ft} + 2 \text{ ft} + 8 \text{ ft}) / (19 \text{ ft}) = 0.68$$

$$r = 1/(1+0.25/0.68) = 0.73$$

$$F_{psw,ult,wind} = (F_{psw,wind})(SF) = (7562 \text{ lb})(2.0) = 15,124 \text{ lb}$$

$$F_{psw,ult,seismic} = (F_{psw,seismic})(SF) = (3876 \text{ lb})(2.5) = 9690 \text{ lb}$$

Substituting in the above equation,

$$\Delta_{wind} = 7.9 \times 10^{-13} (V_{d,wind})^{2.8}$$

$$\Delta_{seismic} = 2.7 \times 10^{-12} (V_{d,seismic})^{2.8}$$

For the design wind load of 3,000 lb and the design seismic load of 1,000 lb (assumed for the purpose of this example), the drift is estimated as follows—

$$\Delta_{wind} = 7.9 \times 10^{-13} (3,000)^{2.8} = 0.004 \text{ inch}$$

$$\Delta_{seismic} = 2.7 \times 10^{-12} (1,000)^{2.8} = 0.01 \text{ inch}$$

Note: The reader is reminded of the uncertainties in determining drift, as discussed in example 6.1 and also in chapter 6. For seismic design, some codes may require the design seismic drift to be amplified (multiplied) by a factor of 4 to account for the potential actual forces that may be experienced relative to the design forces that are determined using an R factor; refer to chapter 3 for additional discussion. Thus, the amplified drift may be determined as 4 x 0.01 inch = 0.04 inch. If the seismic shear load is magnified, however (that is, 4 x 1,000 lb = 4,000 lb), to account for a possible actual seismic load (not modified for the seismic response of the shear wall system), the seismic drift calculated in the above equation becomes 0.03 inch, which is minimally greater. The load adjustment is equivalent to the use of an R of 1.5 instead of 6 in equation 3.8-1 of chapter 3. This latter approach of magnifying the load is not required in the existing building codes for drift determination, however. As mentioned, drift is not usually considered in residential design. Finally, the preceding equations may be used to determine a

load-drift curve for a perforated shear wall for values of V_d ranging from 0 to $F_{psw,ult}$. Although the curve represents the nonlinear behavior of a perforated shear wall, it should only be considered a representation, not an exact solution.

Conclusion In this example, the determination of the design shear capacity of a perforated shear wall was presented for seismic design and wind design applications. Issues related to connection design for base shear transfer and overturning forces (chord tension) were also discussed, and calculations (or conservative assumptions) were made to estimate these forces. In particular, issues related to capacity-based design and “balanced design” of connections were discussed. Finally, a method to determine the load-drift behavior of a perforated shear wall line was presented. The final design may vary, based on designer decisions and judgments (as well as local code requirements) related to the considerations and calculations as given in this example.

The chord tension and compression forces are determined following the same method as used in example 6.1 for the segmented shear wall design method, but only for the first wall segment in the perforated shear wall line (that is, the restrained segment); therefore, the tension forces at the end of the wall are identical to those calculated in example 6.1.

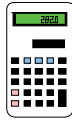

Given The example shear wall, assumed loading conditions, and dimensions are shown in the figure below.

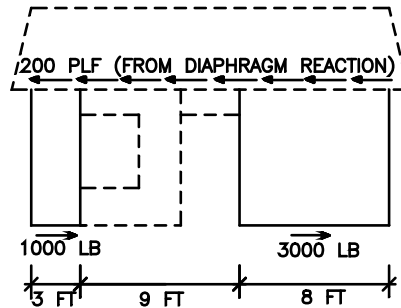

Find The maximum collector tension force.

Solution The collector force diagram that follows is based on the shear wall and loading conditions in the preceding figure.

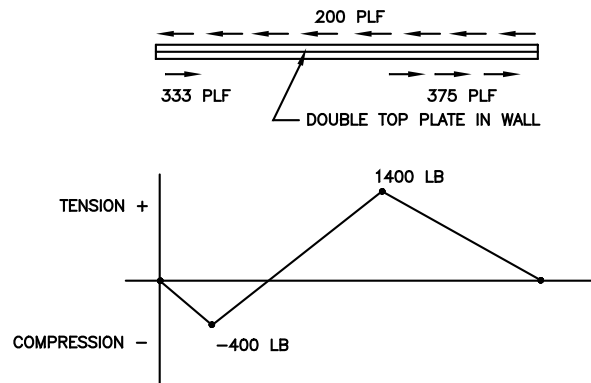

The first point at the interior end of the left shear wall segment is determined as follows—

$$200 \text{ plf} (3 \text{ ft}) - 333 \text{ plf} (3 \text{ ft}) = -400 \text{ lb (compression force)}$$

The second point at the interior end of the right shear wall segment is determined as follows—

$$-400 \text{ lb} + 200 \text{ plf} (9 \text{ ft}) = 1,400 \text{ lb (tension force)}$$

The collector load at the rightmost end of the wall returns to zero, as follows—

$$1,400 \text{ lb} - 375 \text{ plf} (8 \text{ ft}) + 200 \text{ plf} (8 \text{ ft}) = 0 \text{ lb}$$

Conclusion The maximum theoretical collector tension force is 1,400 lb at the interior edge of

the 8-ft shear wall segment. The analysis does not consider the contribution of the “unrestrained” wall portions that are not designated shear wall segments and that would serve to reduce the amount of tension (or compression) force developed in the collector. In addition, the load path assumed in the collector does not consider the system of connections and components that may share load with the collector (wall sheathing and connections, floor or roof construction above and their connections, and so forth). The collector load determined by assuming the top plate acts as an independent element can be considered very conservative, therefore, depending on the wall-floor/roof construction conditions. Regardless, typical practice is to design the collector (and any splices in the collector) to resist a tension force as calculated in this example. The maximum compressive force in the example collector is determined by reversing the loading direction and is equal in magnitude to the maximum tension force. Compressive forces rarely are a concern when at least a double top plate is used as a collector, particularly when the collector is braced against lateral buckling by attachment to other construction (as would generally be necessary to deliver the load to the collector from elsewhere in the building).

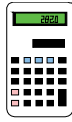
**Given**

The example floor diaphragm and its loading and support conditions are shown in the figure below. The relevant dimensions and loads are as follows—

$$\begin{aligned} d &= 24 \text{ ft} \\ l &= 48 \text{ ft} \\ w &= 200 \text{ plf} \quad (\text{from wind or seismic lateral load})^* \end{aligned}$$

*Related to the diaphragm's tributary load area; see chapter 3 and discussions in this chapter.

The shear walls are equally spaced, and it is assumed that the diaphragm is flexible (that is, experiences beam action) and that the shear wall supports are rigid. This assumption is not correct because the diaphragm may act as a “deep beam” and distribute loads to the shear wall by “arching” action rather than bending action. Also, the shear walls cannot be considered to be perfectly rigid or to exhibit equivalent stiffness except when designed exactly the same with the same interconnection stiffness and base support stiffness. Regardless, the assumptions made in this example are representative of typical practice.

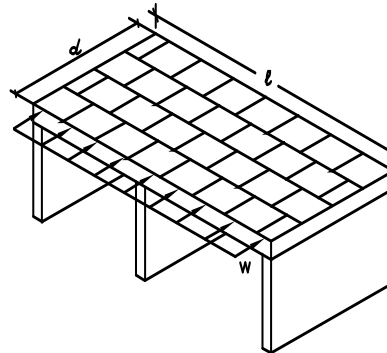
**Find**

1. The maximum design unit shear force in the diaphragm (assuming simple beam action) and the required diaphragm construction.
2. The maximum design moment in the diaphragm (assuming simple beam action) and the associated chord forces.

Solution

1. The maximum shear force in the diaphragm occurs at the center shear wall support. Using the beam equations in appendix A for a 2-span beam, the maximum shear force is determined as follows—

$$V_{\max} = \frac{5}{8} w \left(\frac{l}{2} \right) = \frac{5}{8} (200 \text{ plf}) \left(\frac{48 \text{ ft}}{2} \right) = 3,000 \text{ lb}$$

The maximum design unit shear in the diaphragm is determined as follows—
From table 6.4, the lightest unblocked diaphragm provides adequate resistance.
Unblocked means that the panel edges perpendicular to the framing (that is, joists

or rafters) are not attached to blocking. The perimeter, however, is attached to a continuous member to resist chord forces. For typical residential floor construction, a 19/32-inch thick subfloor may be used, which would provide at least 800 plf of design shear capacity. In typical roof construction, a minimum 15/32-inch thick sheathing is used, which would provide about 800 plf of design shear capacity; however, residential roof construction usually does not provide the edge conditions (that is, a continuous band joist of 2x lumber) associated with the diaphragm values in table 6.4. Regardless, roof diaphragm performance has rarely (if ever) been a problem in light-frame residential construction, and these values often are used to approximate roof diaphragm design values.

Note: The shear forces at other regions of the diaphragm and at the locations of the end shear wall supports can be determined in a similar manner using the beam equations in appendix A. These shear forces are equivalent to the connection forces that must transfer shear between the diaphragm and the shear walls at the ends of the diaphragm. For the center shear wall, however, the reaction (connection) force is twice the unit shear force in the diaphragm at that location (see beam equations in appendix A); therefore, the connection between the center shear wall and the diaphragm in this example must resist a design shear load of $2 \times 125 \text{ plf} = 250 \text{ plf}$. This load is very dependent on the assumption of a “flexible” diaphragm and “rigid” shear walls, however.

2. The maximum moment in the diaphragm also occurs at the center shear wall support. Using the beam equations in appendix A, the maximum moment is determined as follows—

$$M_{\max} = \frac{1}{8} w \left(\frac{l}{2} \right)^2 = \frac{1}{8} (200 \text{ plf}) \left(\frac{48 \text{ ft}}{2} \right)^2 = 14,400 \text{ ft} \cdot \text{lb}$$

The maximum chord tension and compression forces are at the same location and are determined as follows, based on the principle of a force couple that is equivalent to the moment.

$$T = C = \frac{M_{\max}}{d} = \frac{14,400 \text{ ft} \cdot \text{lb}}{24 \text{ ft}} = 600 \text{ lb}$$

The chord members (that is, band joist and associated wall or foundation framing that is attached to the chord) and splices must therefore be able to resist 600 lb of tension or compression force. Generally, these forces are adequately resisted by the framing systems bounding the diaphragm; however, the adequacy of the chords should be verified by the designer, based on experience and analysis as above.

- Conclusion** In this example, the basic procedure and principles for horizontal diaphragm design were presented. Assumptions required to conduct a diaphragm analysis based on conventional beam theory were also discussed.

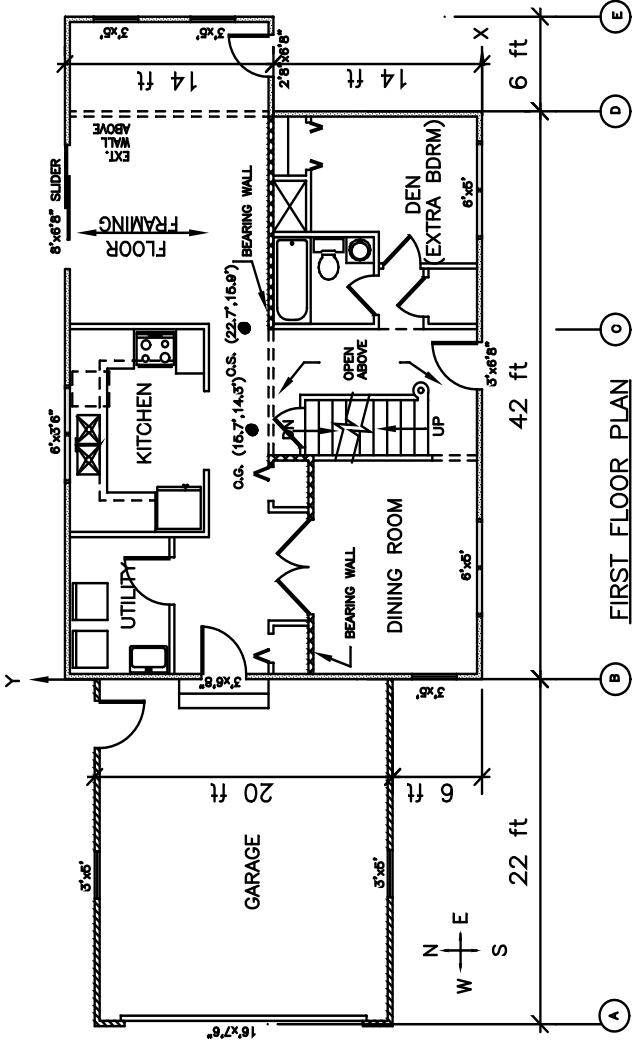
	<p>Given</p>	<p><u>General</u></p> <p>In this example, the first floor plan of a typical two-story house with an attached garage (see the following figure) is used to demonstrate the three methods of distributing shear loads discussed in chapter 6, section 6.4.2. The first story height is 8 ft (that is, 8 ft ceiling height). Only the load in the North-South (N-S) direction is considered in the example; in a complete design, the load in the East-West (E-W) direction would also need to be considered.</p>
		 <p style="text-align: center;">FIRST FLOOR PLAN</p>
		<p><u>Lateral Load Conditions</u></p> <p>The following design N-S lateral loads are determined for the story under consideration, using the methods described in chapter 3 for wind and seismic loads. A fairly high wind load and seismic load condition is assumed for the purpose of the example.</p> <p>Design N-S Wind Lateral Load (120 mph gust, exposure B)</p>

		<p>House: 17,411 lb total story shear Garage: 3,928 lb total story shear Total: 21,339 lb</p> <p>Design N-S Seismic Lateral Load (mapped $S_s = 1.5g$)</p> <p>House: 7,493 lb total story shear (tributary weight is 37,464 lb) Garage: 1,490 lb total story shear (tributary weight is 7,452 lb) Total: 8,983 lb</p> <p><u>Designation of Shear Walls in N-S Direction</u></p> <p>Initially, four N-S lines are designated in the first story for shear wall construction. The wall lines are A, B, D, and E. If needed, an interior wall line may also be designated and designed as a shear wall (see wall line C in the preceding figure).</p>
		<p>The available length of full-height wall segments in each N-S shear wall line is estimated as follows from the floor plan</p> <p>Wall Line A: 2 ft + 2 ft = 4 ft (garage return walls) Wall Line B: 1.33 ft* + 11 ft + 9 ft = 20 ft (garage/house shared wall) Wall Line D: 14 ft = 14 ft (den exterior wall) Wall Line E: 2 ft + 3 ft + 2 ft = 7 ft (living room exterior wall) Total: = 45 ft</p> <p>*The narrow 1.33 ft segment is not included in the analysis because the segment's aspect ratio is 8 ft/1.33 ft = 6 ft, which is greater than the maximum allowable of 4 ft. Some current building codes may restrict the segment aspect ratio to a maximum of 2 or 3.5, depending on the code and the edition in local use. In such a case, many of the usable shear wall segments would be eliminated (that is, all of the 2 ft segments). Thus, the garage opening wall would require larger segments, a portal frame (see section 6.5.2.5), or transfer of the garage shear load to the house by torsion (that is, treat the garage as a cantilever projecting from the house under a uniform lateral load).</p>
	Find	<ol style="list-style-type: none"> Using the “total shear method” of horizontal shear load distribution, determine the total length of shear wall required and the required shear wall construction in the N-S direction. Using the “relative stiffness method” of horizontal shear load distribution, determine the shear loads on the N-S shear wall lines.
	Solution	
	1.	<p>Using the total shear approach, determine the unit shear capacity required, based on the given amount of available shear wall segments in each N-S wall line and the total N-S shear load.</p> <p>In this part of the example, it is assumed that the wall lines will be designed as segmented shear wall lines. From the given information, the total length of N-S shear wall available is 45 ft. Typical practice in this method is to not include segments with aspect ratios greater than 2 because stiffness effects on the narrow segments are not explicitly considered. This would eliminate the 2 ft segments, and the total available length of shear wall would be 45 ft – 8 ft = 37 ft in the N-S direction.</p> <p>The required design unit shear capacity of the shear wall construction and ultimate capacity are determined as follows for the N-S lateral design loads.</p>

		<p><u>Wind N-S</u></p> $F'_{s,wind} = (21,339 \text{ lb})/37 \text{ ft} = 576 \text{ plf}$ $F_{s,wind} = (F'_{s,wind})(SF) = (576 \text{ plf})(2.0) = 1,152 \text{ plf}$ <p>Thus, the unfactored (ultimate) and unadjusted unit shear capacity for the shear walls must meet or exceed 1,152 plf. Assuming that standard 1/2-thick GWB finish is used on the interior wall surfaces (80 plf minimum from table 6.3), the required ultimate capacity of the exterior sheathing is determined as follows—</p> $F_{s,wind} = F_{s,ext} + F_{s,int}$ $F_{s,ext} = 1,152 \text{ plf} - 80 \text{ plf} = 1,072 \text{ plf}$ <p>From table 6.1, any of the wall constructions that use 2-inch nail spacing at the panel perimeter exceed this requirement. By specifying a 3/8-inch thick Structural I wood structural panel with 8d common nails spaced at 2 inches on center on the panel edges (12 inches on center in the panel field), the design of the wall construction is complete, and hold-down and base shear connections must be designed.</p>
		<p><u>Seismic N-S</u></p> $F'_{s,seismic} = (8,983 \text{ lb})/37 \text{ ft} = 243 \text{ plf}$ $F_{s,seismic} = (F'_{s,seismic})(SF) = (243 \text{ plf})(2.5) = 608 \text{ plf}$ <p>Thus, the unfactored (ultimate) and unadjusted unit shear capacity for the wall line must meet or exceed 608 plf. Because seismic codes do not permit the consideration of a 1/2-thick GWB interior finish, the required ultimate capacity of the exterior sheathing is determined as follows:</p> $F_{s,seismic} = F_{s,ext} = 608 \text{ plf}$ <p>From table 6.1, any of the wood structural panel wall constructions that use 6-inch nail spacing at the panel perimeter exceed this requirement. By specifying 3/8-inch thick Structural I wood structural panels with 8d common nails spaced at 6 inches on center on the panel edges (12 inches on center in the panel field), the design of the wall construction is complete, and hold-down and base shear connections must be designed.</p> <p>The base shear connections may be designed in this method by considering the total length of continuous bottom plate in the N-S shear wall lines. As estimated from the plan, this length is approximately 56 feet. Thus, the base connection design shear load (parallel to the grain of the bottom plate) is determined as follows:</p> $\text{Base wind design shear load} = (21,339 \text{ lb})/(56 \text{ ft}) = 381 \text{ plf}$ $\text{Base seismic design shear load} = (8,983 \text{ lb})/(56 \text{ ft}) = 160 \text{ plf}$ <p>The base shear connections may be designed and specified following the methods discussed in chapter 7—Connections. A typical 5/8-inch diameter anchor bolt spaced at 6 feet on center or standard bottom plate nailing may be able to resist as much as 800 plf (ultimate shear capacity), which would provide a “balanced” design capacity of 400 plf or 320 plf for wind and seismic design, with safety factors of 2.0 and 2.5, respectively. Thus, a conventional wall bottom plate connection may be adequate for the preceding conditions; refer to chapter 7 for connection design information and the</p>

			<p>discussion in section 7.3.6 for more details on tested bottom plate connections.</p> <p>If the roof uplift load is not completely offset by 0.6 times the dead load at the base of the first story wall, then strapping to transfer the net uplift from the base of the wall to the foundation or construction below must be provided.</p> <p>The hold-down connections for each shear wall segment in the designated shear wall lines are designed in the manner shown in example 6.1. Any overturning forces originating from shear walls on the second story must also be included, as described in section 6.4.2.4.</p>
			<p><i>Notes:</i></p> <ol style="list-style-type: none"> 1. The contribution of the interior walls to the lateral resistance is neglected in the preceding analysis for wind and seismic loading. As discussed in chapter 6, these walls can contribute significantly to the lateral resistance of a home and serve to reduce the designated shear wall loads and connection loads through alternate, “nondesignated” load paths. In this example, approximately 40 ft of interior partition walls in the N-S direction each have a minimum length of about 8 ft or more (small segments not included). Assuming a design unit shear value of $80 \text{ plf} / 2 = 40 \text{ plf}$ (safety factor of 2), the design lateral resistance may be at least $40 \text{ ft} \times 40 \text{ plf} = 1,600 \text{ lb}$. Although that is not a large amount, it should factor into the design consideration, particularly when a lateral design solution is considered to be marginal, based on an analysis that does not consider interior partition walls. 2. Given the lower wind shear load in the E-W direction, the identical seismic story shear load in the E-W direction, and the greater available length of shear wall in the E-W direction, an adequate amount of lateral resistance should be no problem for shear walls in the E-W direction. Some of the available E-W shear wall segments may not even be required to be designed and detailed as shear wall segments. Also, with hold-down brackets at the ends of the N-S walls that are detailed to anchor a common corner stud (to which the corner sheathing panels on each wall are fastened with the required panel edge fastening), the E-W walls are essentially perforated shear wall lines and may be treated as such in evaluating the design shear capacity of the E-W wall lines. 3. The distribution of the house shear wall elements seems to be reasonably “even” in this example; however, the garage opening wall could be considered a problem if sufficient connection of the garage to the house is not provided to prevent the garage from rotating separately from the house under the N-S wind or seismic load. Thus, the garage walls and garage roof diaphragm should be adequately attached to the house so that the garage and house act as a structural unit. The process will be detailed in the next part of this example.
		2.	<p>Determine the shear loads on the N-S shear wall lines, using the relative stiffness method and an assumed shear wall construction for the given seismic design condition only.</p> <p>Assume that the shear wall construction will be as follows—</p> <ul style="list-style-type: none"> • 7/16-inch OSB Structural I wood structural panel sheathing with 8d common nails (or 0.131-inch diameter 8d pneumatic nails) spaced at 4 inches on center on the panel edges and 12 inches in the panel field. • Douglas-fir wall framing is used, with 2x studs spaced at 16 inches on center. • Walls are designed as perforated shear wall lines, and adequate hold-

		<p>downs and base shear connections are provided.</p> <p>It will be further assumed that the house and garage are sufficiently tied together to act as a structural unit. The designer must remember that the relative stiffness design approach is predicated on the assumption that the horizontal diaphragm is rigid in comparison to the supporting shear walls so that the forces are distributed according to the relative stiffness of the shear wall lines.</p> <p>As given for the design example, the following design seismic shear loads apply to the first story of the example building:</p> <p>Design N-S Seismic Lateral Load (mapped $S_s = 1.5g$)</p> <p>House: 7,493 lb total story shear (tributary weight is 37,464 lb) Garage: 1,490 lb total story shear (tributary weight is 7,452 lb) Total: 8,983 lb total story shear (total tributary weight is 44,916 lb)</p>
		<p><u>Locate the center of gravity.</u></p> <p>The first step is to determine the center of gravity of the building at the first story level; the total seismic story shear load will act through this point. For wind design, the process is similar, but the horizontal wind forces on various portions of the building (based on vertical projected areas and wind pressures) are used to determine the force center for the lateral wind loads (that is, the resultant of the garage and house lateral wind loads).</p> <p>Establishing the origin of an x-y coordinate system at the bottom corner of wall line B of the example first floor plan, the center of gravity is determined by taking weighted moments about each coordinate axis using the center of gravity location for the garage and house portions. Again, the “bump-out” area in the living room is considered to have negligible impact on the estimate of the center of gravity because most of the building mass originates from the second story and roof, which do not have the “bump-out” in the plan.</p> <p>The center of gravity of the garage has the (x, y) coordinates of (-11 ft, 16 ft). The center of gravity of the house has the coordinates (21 ft, 14 ft).</p> <p>Weighted moments about the y-axis—</p> $X_{cg,building} = [(X_{cg,garage})(garage\ weight) + (X_{cg,house})(house\ weight)] / (total\ weight)$ $= [(-11\ ft)(7,452\ lb) + (21\ ft)(37,464\ lb)] / (44,916\ lb)$ $= 15.7\ ft$ <p>Weighted moments about the x-axis—</p> $Y_{cg,building} = [(Y_{cg,garage})(garage\ weight) + (Y_{cg,house})(house\ weight)] / (total\ weight)$ $= [(16\ ft)(7,452\ lb) + (14\ ft)(37,464\ lb)] / (44,916\ lb)$ $= 14.3\ ft$ <p>Thus, the center of gravity for the first story is located at the (x,y) coordinates of (15.7 ft, 14.3 ft). The approximate location on the floor plan is about 4 inches north of the center bearing wall line and directly in front of the stairwell leading down (that is, about 5 feet to the left of the center of the house).</p>
		<p><u>Locate the center of resistance.</u></p>

		<p>The center of resistance is somewhat more complicated to determine and requires an assumption regarding the shear wall stiffness. Two methods of estimating the relative stiffness of segmented shear walls are generally recognized. One method bases the segmented shear wall stiffness on its length; thus, longer shear walls have greater stiffness (and capacity). This method is less appealing when multiple segments are included in one wall line, however, and particularly when the segments have varying aspect ratios, especially narrow aspect ratios, which affect stiffness disproportionately to the length.</p> <p>The second method bases the segmented shear wall stiffness on the shear capacity of the segment, which is more appealing when various shear wall constructions are used with variable unit shear values and when variable aspect ratios are used, particularly when the unit shear strength is corrected for narrow aspect ratios. The method based on strength also is appropriate to use with the perforated shear wall method because the length of a perforated shear wall has little to do with its stiffness or strength. Rather, the number of openings in the wall (as well as its construction) governs its stiffness and capacity. The method used in this example, therefore, will use the capacity of the perforated shear wall lines as a measure of relative stiffness. The same technique may be used with a segmented shear wall design method by determining the shear capacity of each shear wall line (comprising one or more shear wall segments), as shown in example 6.1.</p> <p>First, the strength of each shear wall line in the building must be determined. Using the perforated shear wall method and the assumed wall construction given at the beginning of step 2, the design shear wall line capacities (see below) are determined for each of the exterior shear wall lines in the building. The window and door opening sizes are shown on the plan so that the perforated shear wall calculations can be done, as demonstrated in example 6.2. It is assumed that no interior shear wall lines will be used (except at the shared wall between the garage and the house) and that the contribution of the interior partition walls to the stiffness of the building is negligible. As mentioned, this assumption can overlook a significant factor in the lateral resistance and stiffness of a typical residential building.</p> <p>PSW 1: $F_{psw1} = 7,812$ lb (wall line D) PSW 2: $F_{psw2} = 3,046$ lb (wall line E) PSW 3: $F_{psw3} = 14,463$ lb (north side wall of house) PSW 4: $F_{psw4} = 9,453$ lb (north side of garage) PSW 5: $F_{psw5} = 182$ lb (wall line A; garage opening) PSW 6: $F_{psw6} = 9,453$ lb (south side wall of garage) PSW 7: $F_{psw7} = 9,687$ lb (wall line B) PSW 8: $F_{psw8} = 11,015$ lb (south side wall of house at front)</p> <p>The center of stiffness on the y-coordinate is now determined as follows, using the above PSW design shear capacities for wall lines oriented in the E-W direction—</p> $Y_{cs} = [(F_{psw3})(Y_{psw3}) + (F_{psw4})(Y_{psw4}) + (F_{psw6})(Y_{psw6}) + (F_{psw8})(Y_{psw8})]/(F_{psw,E-w})$ $= [(14,463 \text{ lb})(28 \text{ ft}) + (9,453 \text{ lb})(26 \text{ ft}) + (9,453 \text{ lb})(6 \text{ ft}) + (11,015 \text{ lb})(0 \text{ ft})]/(44,384 \text{ lb})$ $= 15.9 \text{ ft}$ <p>The center of stiffness on the x-coordinate is determined similarly, considering the wall lines oriented in the N-S direction—</p>
--	--	---

			$X_{cs} = [(F_{psw1})(X_{psw1}) + (F_{psw2})(X_{psw2}) + (F_{psw5})(X_{psw5}) + (F_{psw7})(X_{psw7})]/(F_{psw,N-S})$ $= [(7,812 \text{ lb})(42 \text{ ft}) + (3,046 \text{ lb})(48 \text{ ft}) + (182 \text{ lb})(-22 \text{ ft}) + (9,687 \text{ lb})(0 \text{ ft})]/(20,727 \text{ lb})$ $= 22.7 \text{ ft}$
			<p>The coordinates of the center of stiffness, therefore, are 22.7 ft, 15.9 ft. Thus, the center of stiffness is located to the right of the center of gravity (force center for the seismic load) by 22.7 ft – 15.7 ft = 7 ft. This offset between the center of gravity and the center of resistance will create a torsional response in the N-S seismic load direction under consideration. For E-W seismic load direction, the offset (in the y-coordinate direction) is only 15.9 ft – 14.3 ft = 1.6 ft, which is practically negligible from the standpoint of torsional response. The designer should remember that, in both loading directions, the influence of interior partitions on the center of stiffness (and thus the influence on torsional response) is not considered. To conservatively account for this condition and for possible error in locating the actual center of gravity of the building (that is, accidental torsion), codes usually require that the distance between the center of gravity and the center of stiffness be considered as a minimum of 5 percent of the building dimension perpendicular to the direction of seismic force under consideration. This condition is essentially met in this example because the offset dimension for the N-S load direction is 7 feet, which is 10 percent of the E-W plan dimension of the house and attached garage.</p>
			<p><u>Distribute the direct shear forces to N-S walls.</u></p> <p>The direct shear force is distributed to the N-S walls based on their relative stiffness, without regard to the location of the center of stiffness (resistance) and the center of gravity (seismic force center), or the torsional load distribution that occurs when they are offset from each other. The torsional load distribution is superimposed on the direct shear forces on the shear wall lines in the next step of the process.</p> <p>The direct seismic shear force of 8,983 lb is distributed as shown herein, based on the relative stiffness of the perforated shear wall lines in the N-S direction. As before, the relative stiffness is based on the design shear capacity of each perforated shear wall line relative to that of the total design capacity of the N-S shear wall lines.</p> <p>Direct shear on PSW1, PSW2, PSW5, and PSW7 is determined as follows—</p> $\begin{aligned} \text{(total seismic shear load on story)}[(F_{psw1})/(F_{psw,N-S})] &= (8,983 \text{ lb})[(7,812 \text{ lb})/(20,727 \text{ lb})] \\ &= (8,983 \text{ lb})[0.377] \\ &= 3,387 \text{ lb} \end{aligned}$ $\begin{aligned} \text{(total seismic shear load on story)}[(F_{psw2})/(F_{psw,N-S})] &= (8,983 \text{ lb})[(3,046 \text{ lb})/(20,727 \text{ lb})] \\ &= (8,983 \text{ lb})[0.147] \\ &= 1,321 \text{ lb} \end{aligned}$ $\begin{aligned} \text{(total seismic shear load on story)}[(F_{psw5})/(F_{psw,N-S})] &= (8,983 \text{ lb})[(182 \text{ lb})/(20,727 \text{ lb})] \\ &= (8,983 \text{ lb})[0.009] \\ &= 81 \text{ lb} \end{aligned}$

			$\begin{aligned} \text{(total seismic shear load on story)}[(F_{psw7})/(F_{psw,N-S})] &= (8,983 \text{ lb})[(9,687 \text{ lb})/(20,727 \text{ lb})] \\ &= (8,983 \text{ lb})[0.467] \\ &= 4,195 \text{ lb} \end{aligned}$			
			<p><u>Distribute the torsion load.</u></p> <p>The torsional moment is created by the offset of the center of gravity (seismic force center) from the center of stiffness or resistance (also called the center of rigidity). For the N-S load direction, the torsional moment is equal to the total seismic shear load on the story, multiplied by the x-coordinate offset of the center of gravity and the center of stiffness (that is, 8,983 lb x 7 ft = 62,881 ft-lb). The sharing of this torsional moment on all of the shear wall lines is based on the torsional moment of resistance of each wall line. The torsional moment of resistance is determined by the design shear capacity of each wall line (used as the measure of relative stiffness) multiplied by the square of its distance from the center of stiffness. The amount of the torsional shear load (torsional moment) distributed to each wall line is then determined by each wall's torsional moment of resistance in proportion to the total torsional moment of resistance of all shear wall lines combined. The torsional moment of resistance of each shear wall line and the total for all shear wall lines (torsional moment of inertia) is determined as shown below.</p>			
			Wall Line	F_{psw}	Distance from Center of Resistance	$F_{psw}(d)^2$
			PSW1	7,812 lb	19.3 ft	$2.91 \times 10^6 \text{ lb-ft}^2$
			PSW2	3,046 lb	25.3 ft	$1.95 \times 10^6 \text{ lb-ft}^2$
			PSW3	14,463 lb	12.1 ft	$2.12 \times 10^6 \text{ lb-ft}^2$
			PSW4	9,453 lb	10.1 ft	$9.64 \times 10^5 \text{ lb-ft}^2$
			PSW5	182 lb	44.7 ft	$3.64 \times 10^5 \text{ lb-ft}^2$
			PSW6	9,453 lb	9.9 ft	$9.26 \times 10^5 \text{ lb-ft}^2$
			PSW7	9,687 lb	22.7 ft	$4.99 \times 10^6 \text{ lb-ft}^2$
			PSW8	11,015 lb	15.9 ft	$2.78 \times 10^6 \text{ lb-ft}^2$
			Total torsional moment of inertia (J)			$1.70 \times 10^7 \text{ lb-ft}^2$
			<p>The torsional shear load on each wall is determined using the following basic equation for torsion—</p> $V_{WALL} = \frac{M_T d(F_{WALL})}{J}$ <p>where,</p> <p>V_{WALL} = the torsional shear load on the wall line (lb) M_T = the torsional moment* (lb-ft) d = the distance of the wall from the center of stiffness (ft) F_{WALL} = the design shear capacity of the segmented or perforated shear wall line (lb) J = the torsional moment of inertia for the story (lb-ft²)</p> <p>*The torsional moment is determined by multiplying the design shear load on the story by the offset of the center of stiffness relative to the center of gravity, perpendicular to the load direction under consideration. For wind design, the center of the vertical projected area of the building is used in lieu of the center of gravity.</p>			

			<p>Now the torsional loads may be determined as follows for the N-S and E-W wall lines. For PSW1 and PSW2, the torsion load is in the reverse direction of the direct shear load on these walls. This behavior is the result of the center of shear resistance being offset from the force center, which causes rotation around the center of stiffness (<i>center of shear resistance</i> and <i>center of stiffness</i> may be used interchangeably because the shear resistance is assumed to represent stiffness). If the estimated offset of the center of gravity and the center of stiffness is reasonably correct, then the torsional response will tend to reduce the shear load on PSW1 and PSW2; however, codes generally do not allow the direct shear load on a wall line to be reduced because of torsion; only increases should be considered.</p> <p>The following values for use in the torsion equation apply to this example—</p> $M_T = (8,983 \text{ lb})(7 \text{ ft}) = 62,881 \text{ ft-lb}$ $J = 1.70 \times 10^7 \text{ lb-ft}^2$ <p>The torsional loads on PSW5 and PSW7 are determined as follows—</p> $V_{psw5} = (62,881 \text{ ft-lb})(44.7 \text{ ft})(182 \text{ lb}) / (1.70 \times 10^7 \text{ lb-ft}^2)$ $= 30 \text{ lb}$ $V_{psw7} = (62,881 \text{ ft-lb})(22.7 \text{ ft})(9,687 \text{ lb}) / (1.70 \times 10^7 \text{ lb-ft}^2)$ $= 813 \text{ lb}$ <p>These torsional shear loads are added to the direct shear loads for the N-S walls, and the total design shear load on each wall line may be compared to its design shear capacity as follows—</p>					
			N-S Wall Lines	Wall Design Capacity, F_{psw} (lb)	Direct Shear Load (lb)	Torsional Shear Load (lb)	Total Design Shear Load (lb)	Percent of Design Capacity Used
			PSW1	7,812	3,387	n/a*	3,387	43% (OK)
			PSW2	3,046	1,321	n/a*	1,321	43% (OK)
			PSW5	182	81	30	111	61% (OK)
			PSW7	9,687	4,195	813	5,008	52% (OK)
			*The torsional shear load is actually in the reverse direction of the direct shear load for these walls, but it is not subtracted, as required by code.					
			<p>Although all of the N-S shear wall lines have sufficient design capacity, the wall lines on the left side (west) of the building are noticeably “working harder,” and the walls on the right side (east) of the building are substantially overdesigned. The wall construction could be changed to allow greater sheathing nail spacing on walls PSW1 and PSW2. Also, the assumption of a rigid diaphragm over the entire expanse of the story is questionable, even if the garage is “rigidly” attached to the house with adequate connections. The loads on walls PSW5 and PSW7 will likely be higher than predicted using the relative stiffness method. Certainly, reducing the shear wall construction based on the above analysis is not recommended prior to “viewing” the design from the perspective of the tributary area approach. Similarly, the garage opening wall (PSW5) should not be assumed to be adequate based only on the preceding analysis in view of the inherent assumptions of the relative stiffness</p>					

			method regarding the horizontal distribution of shear forces. For more compact buildings with continuous horizontal diaphragms extending over the entire area of each story, the method is less presumptive; however, this qualitative observation is true of all of the force distribution methods demonstrated in this design example.
		Conclusion	<p>This seemingly simple design example has demonstrated the many decisions, variables, and assumptions to consider in designing the lateral resistance of a light-frame home. An experienced designer may come to favor certain options or standardized solutions and develop them for repeated use in similar conditions. Also, an experienced designer may be able to effectively design using simplified analytical methods (that is, the total shear approach shown in step 1), supplemented with judgment and detailed evaluations of certain constructions or unique details, as appropriate.</p> <p>This example indicates that a 7/16-inch thick Structural I wood structural panel sheathing can be used for all shear wall construction to resist the required wind shear loading. A constant sheathing panel edge nail spacing also is possible by spacing 3 inches on center if the perforated shear wall method is used and 2 inches on center if the segmented shear wall method is used (based on the worst case condition of wall line B). The wall sheathing nails specified were 8d pneumatic nails with a 0.113-inch diameter. In general, this wall construction will be conservative for most wall lines on the first story of the example house. If the seismic shear load were the only factor (that is, the wind load condition was substantially less than assumed), the wall construction could be simplified even more such that a perforated shear wall design approach with a single sheathing fastening requirement may be suitable for all shear wall lines except for the garage opening wall.</p> <p>Finally, designers should avoid numerous variations in construction detailing in a single project because it may lead to confusion and error in the field. Fewer changes in assembly requirements, fewer parts, and fewer special details should all be as important to the design objectives as meeting the required design loads. When the final calculation is done (regardless of the complexity or simplicity of the analytic approach chosen and the associated uncertainties or assumptions), the designer should exercise judgment in making reasonable final adjustments to the design to achieve a practical, well-balanced design. As a critical final consideration, the designer should be confident that the various parts of the structural system are adequately “tied together” to act as a structural unit in resisting the lateral loads. This consideration is as much a matter of judgment as it is a matter of analysis.</p>

6.7 References

- Ambrose, J., and D. Vergun. 1987. *Design for Lateral Forces*. New York: John Wiley & Sons.
- American Iron and Steel Institute (AISI). 1996. *Shear Wall Values for Light Weight Steel Framing*. Publication RP96-19601. Washington, DC: AISI.
- American Society of Testing and Materials (ASTM). 2010. *Standard Methods of Conducting Strength Tests of Panels for Building Construction*, ASTM E72-13a. West Conshohocken, PA: ASTM.
- . 2012. *Standard Practice for Static Load Test for Shear Resistance of Framed Walls for Buildings*, ASTM E-564, West Conshohocken, PA: ASTM.
- American Wood Council (AWC). 2008. *National Design Specification for Wood Construction—Wind and Seismic Supplement*. American Wood Council, Washington, DC.
- . 2012. *National Design Specification for Wood Construction*, ANSI/AF&PA NDS-2012. Washington, DC: AWC.
- APA—The Engineered Wood Association. 1998. *Nail Penetration and Framing Specific Gravity Factors for Shear Walls and Diaphragms*, APA Report T98-22. Tacoma, WA: APA.
- . 2007. *Diaphragms and Shear Walls*. Tacoma, WA: APA.
- . 2008. *Brace Walls with Wood*. Tacoma, WA: APA.
- Boughton, G.N., and G.F. Reardon. 1984. “Simulated Cyclone Wind Tests on a Timber Framed House.” In *Proceedings of the Pacific Timber Engineering Conference*, Vol. 2. Auckland, New Zealand: New Zealand Forest Research Institute: 527–534.
- Christovasilis, I.P., A. Filiatrault, and A. Wanitkorkal. 2007. “Seismic Test of a Full-Scale Two-Story Light-Frame Wood Building: The NEESWood Benchmark Test.” NEESWood report NW-01, MCEER, Buffalo, NY.
- Crandell, Jay H., and Zeno Martin. 2009. “The Story Behind the 2009 IRC Wall Bracing Provisions,” *Wood Design Focus* 19 (1).
- Diekmann, Edward R. 1986. “Design of Wood Diaphragms.” In *Wood: Engineering Design Concepts: A Compilation of Educational Modules for Engineers and Architects at the Fourth Clark C. Heritage Memorial*

Series on Wood, Madison, WI, August 1982. Clark C. Heritage Memorial Series on Wood, Vol. 4. University Park, PA: Materials Education Council, Materials Research Laboratory, Pennsylvania State University: 479–547.

Dolan, J.D., and C.P. Heine. 1997a. *Monotonic Tests of Wood-Frame Shear Walls with Various Openings and Base Restraint Configurations*, Timber Engineering Report No. TE-1997-001. Blacksburg, VA: Virginia Polytechnic Institute and State University.

———. 1997b. *Sequential Phased Displacement Cyclic Tests of Wood-Frame Shear Walls with Various Openings and Base Restraint Configurations*, Timber Engineering Report No. TE-1997-002. Blacksburg, VA: Virginia Polytechnic Institute and State University.

———. 1997c. *Sequential Phased Displacement Tests of Wood-Framed Shear Walls with Corners*, Timber Engineering Report No. TE-1997-003. Blacksburg, VA: Virginia Polytechnic Institute and State University.

Dolan, J.D., and A.C. Johnson. 1996a. *Cyclic Tests of Long Shear Walls with Openings*, Report TE-1996-002. Blacksburg, VA: Virginia Polytechnic Institute and State University.

———. 1996b. *Monotonic Tests of Long Shear Walls with Openings*, Report TE-1996-001. Blacksburg, VA: Virginia Polytechnic Institute and State University.

Federal Emergency Management Agency. 2003. *NEHRP Recommended Provisions and Commentary for Seismic Regulations for New Buildings and Other Structures*. FEMA 450. Washington, DC: FEMA.

———. 2012. *Seismic Evaluation and Retrofit of Multi-Unit Wood-Frame Buildings with Weak First Stories*, FEMA P-807. Washington, DC: FEMA.

Filiatrault, A., Christovasilis, I.P., Wanitkorkal, A., and van de Lindt, J.W. 2010. “Experimental Seismic Response of a Full-Scale Light-Frame Wood Building.” *Journal of Structural Engineering*, 136(3), 246-254.

Filiatrault, A., D. Fischer, B. Folz, and C.-M. Uang. 2002. “Seismic Testing of Two-Story Woodframe House: Influence of Wall Finish Materials,” *Journal of Structural Engineering* 128 (1): 1337–1345.

Filiatrault, A., and R.O. Foschi. 1991. “Static and Dynamic Tests of Timber Shear Walls Fastened with Nails and Wood Adhesive,” *Canadian Journal of Civil Engineering* 18 (5): 749–755.

- Griffiths, D.K., and H.G. Wickens. 1996. "Timber Frame Walls: Design for Racking Resistance." In *Proceedings of the International Wood Engineering Conference*, Vol. 2, edited by Vijaya K. A. Gopu. Madison, WI: Omnipress: 37-44.
- U.S. Department of Housing and Urban Development (HUD). 1999. *Evaluation of Housing Performance and Seismic Design Parameters in the Northridge Earthquake*. Report prepared for the National Association of Home Builders and HUD. Washington, DC: NAHB Research Center, Inc.
- International Code Council, Inc. (ICC). 2012a. *International Building Code*. Washington, DC: ICC.
- . 2012b. *International Residential Code*. Washington, DC: ICC.
- International Code Council Evaluation Services (ICC-ES). 2013. *Power-Driven Staples and Nails*, ESR-1539. Whittier, CA, ICC-ES.
- International Council of Building Officials (ICBO). 1969. Application for Research Committee Recommendation on Alternate Materials or Methods of Construction, K-Lath Corporations, Whittier, CA.
- . 1988. *Uniform Building Code*, Whittier, CA.
- . 1997. *Uniform Building Code*, Whittier, CA.
- Karacabeyli, E., and A. Ceccotti. 1998. *Nailed Wood-Frame Shear Walls for Seismic Loads: Test Results and Design Considerations*, Paper T207-6, Proceedings of the Structural Engineers' World Congress. Reston, VA: American Society of Civil Engineers.
- Kasal, B., R.J. Leichti, and R.Y. Itani. 1994. "Non-Linear Finite Element Model of Complete Light Frame Wood Structures," *Journal of Structural Engineering* 120 (1): 100–119.
- Krawinkler, H., Parisi, F., Ibarra, L., Ayoub, A., and Medina, R., 2000. "Development of a Testing Protocol for Woodframe Structures" CUREE Publication No. W-02
- Li, M., F. Lam, B.J. Yeh, T. Skaggs, D. Rammer and J. Wacker. 2012. "Modeling Force Transfer Around Openings in Wood-Frame Shear Walls," *ASCE Journal of Structural Engineering* 138 (12): 1419-1426.

- Mosalam, K.M., and S.A. Mahin. 2007. "Seismic Evaluation and Retrofit of Asymmetric Multi-Story Wood-Frame Building," *Journal of Earthquake Engineering* 11 (6): 968–986.
- National Association of Home Builders (NAHB). 1997. *Monotonic Tests of Cold-Formed Steel Shear Walls with Openings*. Report prepared for the U.S. Department of Housing and Urban Development, American Iron and Steel Institute, and NAHB. Upper Marlboro, MD: NAHB Research Center, Inc.
- . 1998. *The Performance of Perforated Shear Walls with Narrow Wall Segments, Reduced Base Restraint, and Alternative Framing Methods*. Report prepared for the U.S. Department of Housing and Urban Development. Upper Marlboro, MD: NAHB Research Center, Inc.
- . 1999. *Perforated Shear Walls with Conventional and Innovative Base Restraint Connections*. Report prepared for the U.S. Department of Housing and Urban Development. Upper Marlboro, MD: NAHB Research Center, Inc.
- . 2009. *Evaluation of Full-Scale House Testing Under Lateral Loading*, Report #5822-03_01162009. Upper Marlboro, MD: NAHB Research Center, Inc.
- National Bureau of Standards (NBS). 1948. *Strength of Houses: Application of Engineering Principles to Structural Design*, Building Materials and Structures Report 109. Washington, DC: U.S. Department of Commerce and U.S. Government Printing Office.
- National Institute of Standards and Technology (NIST). 1998. *A Summary of the Structural Performance of Single-Family, Wood-Frame Housing*, NISTIR 6224. Gaithersburg, MD: NIST.
- Ni, C., E. Karacabcyli, and A. Ceccotti, D. 1999. Design of Shear Walls with Openings under Lateral and Vertical Loads." in Proceedings of the Pacific Timber Engineering, Rotorua, New Zealand Forest Research Institute: 144-218.
- Patton-Mallory, M., R.M. Gutkowski, and L.A. Soltis. 1984. *Racking Performance of Light Frame Walls Sheathed on Two Sides*, Research Paper FPL, Vol. 448. Madison, WI: U.S. Department of Agriculture, Forest Service, and Forest Products Laboratory.
- Pei, S., J.W. van de Lindt, S.E. Pryor, H. Shimizu, H. Isoda, and D. Rammer. 2010. *Seismic Testing of a Full-Scale Mid-Rise Building: The NEESWood Capstone Test*, NEESWood Project Report NW-04. <http://www.nees.org>.

- Reardon, G.F. 1988. "Effects of Non-Structural Cladding on Timber Framed House Construction." In *Proceedings of the International Conference on Timber Engineering*, Madison, WI, Forest Products Research Society: 276-281.
- Reardon, G.F. 1989. "Effect of Claddings on the Response of Houses to Wind Forces." In *Proceedings of the Second Pacific Timber Engineering Conference*, Vol. 2. University of Auckland: Auckland, New Zealand: 101–105.
- Reardon, G., and D. Henderson. 1996. "Simulated Wind Loading of a Two-Story Test House." In *Proceedings of the International Wood Engineering Conference*, Vol. 4. Madison, WI: Omnipress: 313-319.
- Sugiyama and Matsumoto. 1994. "Empirical Equations for the Estimation of Racking Strength of a Plywood-Sheathed Shear Wall with Openings." In *Summaries of Technical Papers of Annual Meeting*, Architectural Institute of Japan.
- Testing Engineers, Inc. 1970. *Strength Tests of Plastered Building Panels for Keystone Steel and Wire Division*. Testing Engineers, Inc., Oakland, CA.
- . 1971. *Strength Tests of Plastered Building Panels using ASTM E72-61.* Testing Engineers, Inc., Oakland, CA.
- Thurston, S.J. 1994. *Report on Racking Resistance of Long Sheathed Timber Framed Walls with Openings*. Study Report 54 of Building Research Association of New Zealand (BRANZ) Study Report. BRANZ, Judgeford, Wellington, New Zealand.
- Tuomi, R.L. and W.J. McCutcheon. 1974. *Testing of a Full-Scale House Under Simulated Snow Loads and Wind Loads*, U.S. Department of Agriculture, Forest Products Laboratory, Madison, WI.
- van de Lindt, J., S. Pei, S.E. Pryor, H. Shimizu, and H. Isoda. 2010. "Experimental Seismic Response of a Full-Scale Six-Story Light-Frame Wood Building," *ASCE Journal of Structural Engineering* 136 (10): 1262–1272.
- van de Lindt, J.W. and R. Gupta. 2006. "Damage and Damage Prediction for Wood Shearwalls Subjected to Simulated Earthquake Loads." *ASCE Journal of Performance of Constructed Facilities* 20 (2), 176-184.
- van de Lindt, J.W., D.V. Rosowsky, W. Pang, and S. Pei. 2013. "Performance-Based Seismic Design of Midrise Woodframe Buildings," *ASCE Journal of Structural Engineering* 139 (8): 1294–1302.

- White, M.W., and Dolan, J.D. 1993. "Effect of Adhesives on Shear Wall Performance." In *Systems Approach to Wood Structures*. Proceedings. Madison, WI: Forest Products Society.
- Wolfe, R.W. 1983. *Contribution of Gypsum Wallboard to Racking Resistance of Light Frame Walls*, Research Paper FPL 439. Madison, WI: U.S. Department of Agriculture, Forest Service, and Forest Products Laboratory.
- Yokel, F.Y., G. Hsi, and F. Somes. 1973. *Full-Scale Test on a Two-Story House Subjected to Lateral Load*. Washington, DC: U.S. Department of Commerce, National Bureau of Standards.

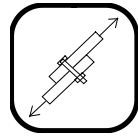

CHAPTER 7

Connections

7.1 General

The objectives of connection design are—

- To transfer loads resisted by structural members and systems to other parts of the structure to form a “continuous load path.”
- To secure nonstructural components and equipment to the building.
- To fasten members in place during construction to resist temporary loads during installation (for example, finishes and sheathing).

Adequate connection of the framing members and structural systems (covered in chapters 4, 5, and 6) is a critical design and construction consideration. Regardless of the type of structure or type of material, structures are only as strong as their connections, and structural systems can behave as a unit only with proper interconnection of the components and assemblies; therefore, this chapter is dedicated to connections. A connection transfers loads from one framing member to another (for example, a stud to a top or bottom plate) or from one assembly to another (for example, a roof to a wall, a wall to a floor, and a floor to a foundation). Connections generally consist of two or more framing members and a mechanical connection device, such as a fastener or specialty connection hardware. Adhesives also are used to supplement mechanical attachment of wall finishes or floor sheathing to wood.

This chapter focuses on conventional wood connections that typically use nails, bolts, and some specialty hardware. The procedures for designing connections are based on the *National Design Specification for Wood Construction* (NDS) (AWC, 2012). The chapter also addresses relevant concrete and masonry connections, in accordance with the applicable provisions of *Building Code Requirements for Structural Concrete* (ACI-318) (ACI, 2011) and

Building Code Requirements for Masonry Structures (TMS 402) (ACI, 2008). When referring to the NDS, ACI-318, or TMS 402, the chapter identifies particular sections as NDS•12.1, ACI-318•22.5, or TMS 402.

For most connections in typical residential construction, the connection design may be based on prescriptive tables found in the applicable residential building code (ICC, 2012) or in other documents referenced in the International Residential Code (ICC, 2012), such as the *Wood Frame Construction Manual* (WFCM).

The NDS recognizes in NDS•7.1.1.4 that “extensive experience” constitutes a reasonable basis for design. The designer may use prescriptive nailing schedules for some connections, but he or she must verify that the connection complies with local requirements, practice, and the design conditions that are assumed for use with the prescriptive schedules. A connection design based on the NDS or other sources, such as the WFCM, may be necessary for special conditions, such as in high-hazard seismic or wind areas and when unique structural details or materials are used. Also, residential framing may incorporate large open spaces, vaulted ceilings, steep pitched roofs (greater than a 45-degree slope), and other elements that may fall outside the parameters of prescriptive designs; connection designs may therefore be required for many of these conditions. Some state and local building codes may require nailing patterns and connection details that are more restrictive than those set out in prescriptive nailing schedules because of local experience with building performance during natural hazard events.

In addition to the conventional fasteners mentioned, many specialty connectors and fasteners are available on today’s market. The reader is encouraged to gather, study, and scrutinize manufacturer literature regarding specialty fasteners, connectors, and tools that meet a wide range of connection needs.

7.2 Types of Mechanical Fasteners

Mechanical fasteners that are generally used for wood-framed house design and construction include the following.

- Nails and spikes.
- Bolts.
- Lag bolts (lag screws).
- Specialty connection hardware.

This section presents some basic descriptions and technical information on those fasteners. Sections 7.3 and 7.4 provide design values and related guidance. Section 7.5 presents design examples for various typical conditions in residential wood framing and foundation construction.

7.2.1 Nails

Several characteristics distinguish one nail from another. Figure 7.1 depicts key nail features for a few types of nails that are essential to wood-framed design and construction. This section discusses some of a nail's characteristics relative to structural design; the reader is referred to *Standard Terminology of Nails for Use With Wood and Wood-Base Materials* (ASTM F547) and *Standard Specification for Driven Fasteners: Nails, Spikes, and Staples* (ASTM F1667) for additional information (ASTM, 2011; 2012).

FIGURE 7.1 *Elements of a Nail and Nail Types*

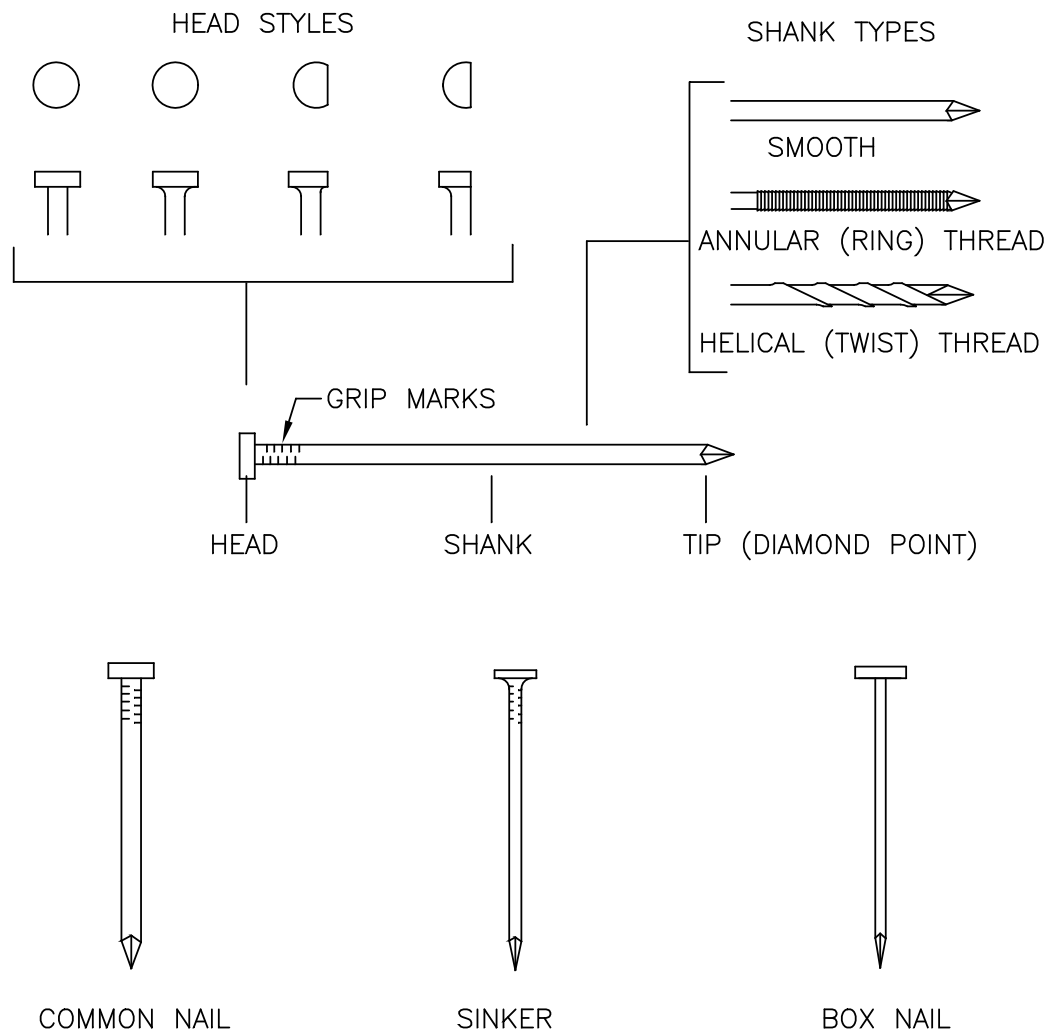

The following are the most common nail types used in residential wood construction.

- *Common nails* are bright, plain-shank nails with a flat head and diamond point. The diameter of a common nail is larger than that of sinkers and box nails of the same length. Common nails are used primarily for rough framing.
- *Sinker nails* are bright or coated slender nails with a sinker head and diamond point. The diameter of the head is smaller than that of a common nail with the same designation. Sinker nails are used primarily for rough framing and applications where lumber splitting may be a concern.
- *Box nails* are bright, coated, or galvanized nails with a flat head and diamond point. They are made of lighter gauge wire than common nails and sinkers and are commonly used for toenailing and many other light framing connections where splitting of lumber is a concern.
- *Cooler nails* are similar to the nails already described but with slightly thinner shanks. They are commonly supplied with ring shanks (that is, annular threads) for use as a drywall nail.
- *Power-driven nails* (and staples) are produced by a variety of manufacturers for several types of power-driven fasteners. Pneumatic-driven nails and staples are the most popular power-driven fasteners in residential construction. Nails are available in a variety of diameters, lengths, and head styles. The shanks are generally cement coated, and some nails are available with deformed shanks for added capacity. Staples also are available in a variety of wire diameters, crown widths, and leg lengths. Refer to ESR-1539 for additional information and design data (ICC-ES, 2013).
- *Ring-shank nails* have rings cut into the shank of the nail and are being increasingly used in attaching roof or wall sheathing to framing members. The rings significantly increase the withdrawal resistance of the nail, and the capacity of ring shank nails could be nearly 50 percent greater than plain shank nails, depending on nail diameter and the wood species into which the nail is driven (AWC, 2012).

Nail lengths and weights are denoted by the *penny weight*, which is indicated by *d*. Given the standardization of common nails, sinkers, and cooler nails, the penny weight also denotes a nail's head and shank diameter. For other nail types, sizes are based on the nail's length and diameter. Table 7.1 arrays dimensions for the nails discussed herein. Nail length and diameter are key factors in determining the strength of nailed connections in wood framing. The steel yield

strength of the nail may also be important for certain shear connections, yet such information is rarely available for a “standard” lot of nails.

TABLE 7.1 *Nail Types, Sizes, and Dimensions^a*

Type of Nail	Nominal Size (penny weight, d)	Length (inches)	Diameter (inches)
Common	6d	2	0.113
	8d	2 1/2	0.131
	10d	3	0.148
	12d	3 1/4	0.148
	16d	3 1/2	0.162
	20d	4	0.192
Box	6d	2	0.099
	8d	2 1/2	0.113
	10d	3	0.128
	12d	3 1/4	0.128
	16d	3 1/2	0.135
Sinker	6d	1 7/8	0.092
	8d	2 3/8	0.113
	10d	2 7/8	0.120
	12d	3 1/8	0.135
	16d	3 1/4	0.148
Pneumatic ^b	6d	1 7/8 to 2	0.092 to 0.113
	8d	2 3/8 to 2 1/2	0.092 to 0.131
	10d	3	0.120 to 0.148
	12d	3 1/4	0.120 to 0.131
	16d	3 1/2	0.131 to 0.162
	20d	4	0.131
Cooler	4d	1 3/8	0.067
	5d	1 5/8	0.080
	6d	1 7/8	0.092

Notes:

^a Based on ASTM F1667 (ASTM, 2011).

^b Based on a survey of pneumatic fastener manufacturer data and ESR-1539 (ICC, 2013).

Although many types of *nail heads* are available, three types are most commonly used in residential wood framing.

- The *flat nail head* is the most common head. It is flat and circular, and its top and bearing surfaces are parallel but with slightly rounded edges.
- The *sinker nail head* is slightly smaller in diameter than the flat nail head. It also has a flat top surface; however, the bearing surface of the nail head is angled, allowing the head to be slightly countersunk.

- *Pneumatic heads* are available in the above types; however, other head types, such as half-round or D-shaped heads, also are common.

The *shank*, as illustrated in figure 7.1, is the main body of a nail. It extends from the head of the nail to the point. It may be plain or deformed. A plain shank is considered a “smooth” shank, but it may have “grip marks” from the manufacturing process. A deformed shank is most often either threaded or fluted to provide additional withdrawal or pullout resistance. Threads are annular (that is, ring shank), helical, or longitudinal deformations rolled onto the shank, creating ridges and depressions. Flutes are helical or vertical deformations rolled onto the shank. Threaded nails most often are used to connect wood to wood, whereas fluted nails are used to connect wood to concrete (for example, sill plate to concrete slab or furring strip to concrete or masonry). Shank diameter and surface condition both affect a nail’s capacity.

The *nail tip*, as illustrated in figure 7.1, is the end of the shank—usually tapered—that is formed during manufacturing to expedite nail driving into a given material. Among the many types of nail points, the *diamond point* is most commonly used in residential wood construction. The diamond point is a symmetrical point with four approximately equal beveled sides that form a pyramid shape. A *cut point* used for concrete cut nails describes a blunt point. The point type can affect nail drivability, lumber splitting, and strength characteristics.

The *material* used to manufacture nails may be steel, stainless steel, heat-treated steel, aluminum, or copper, although the most commonly used materials are steel, stainless steel, and heat-treated steel. *Steel* nails typically are formed from basic steel wire. *Stainless steel* nails often are recommended in exposed construction near the coast or for certain applications, such as cedar siding, to prevent staining. Stainless steel nails also are recommended for permanent wood foundations. *Heat-treated* steel includes annealed, case-hardened, or hardened nails that can be driven into particularly hard materials, such as extremely dense wood or concrete.

Various nail *coatings* provide corrosion resistance, increased pullout resistance, or ease of driving. Following is a description of some of the more common coatings in residential wood construction.

- *Bright*. Uncoated and clean nail surface.
- *Cement-coated*. Coated with a heat-sensitive cement that prevents corrosion during storage and improves withdrawal strength, depending on the moisture and density of the lumber and other factors.
- *Galvanized*. Coated with zinc by barrel-tumbling, dipping, electroplating, flaking, or hot-dipping to provide a corrosion-resistant coating during storage and after installation for either performance or appearance. The coating thickness increases the diameter of the nail and improves withdrawal and shear strength.

7.2.2 Bolts

Bolts often are used for “heavy” connections and to secure wood to other materials, such as steel or concrete. In many construction applications, however, special power-driven fasteners are used in place of bolts. Refer to figure 7.2 for an illustration of some typical bolt types and connections for residential use.

FIGURE 7.2 *Bolt and Connection Types*

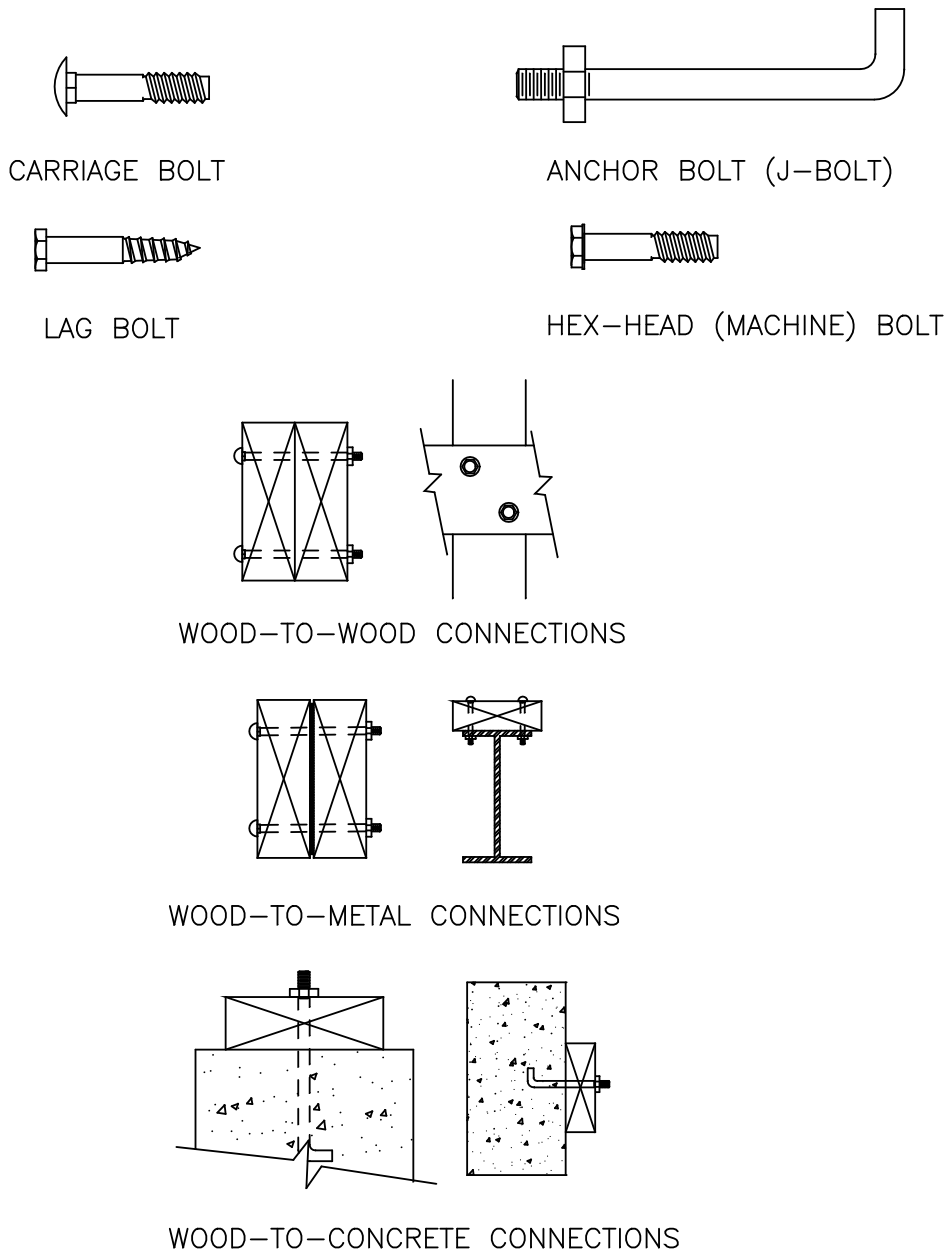

In residential wood construction, bolted connections typically are limited to wood-to-concrete or wood-to-masonry used for foundation connections, unless a home is constructed in a high-hazard wind or seismic area and hold-down brackets are required to transfer shear wall overturning forces (see chapter 6). Foundation bolts, typically embedded in concrete or grouted masonry, are commonly referred to as *anchor bolts*, *J-bolts*, *headed anchor bolts*, or *mud-sill anchors*. Another type of bolt sometimes used in residential construction is the *structural bolt*, which connects wood to steel or wood to wood. Low-strength ASTM A307 bolts commonly are used in residential construction, whereas high-strength ASTM A325 bolts are more common in commercial applications. Bolt diameters in residential construction generally range from 1/4 to 3/4 inch, although 1/2- to 5/8-inch-diameter bolts are most common, particularly for connecting a 2x wood sill to grouted masonry or concrete.

Bolts, unlike nails, are installed in predrilled holes. If holes are too small, the possibility of splitting the wood member increases during installation of the bolt. If bored too large, the bolt holes encourage nonuniform dowel (bolt) bearing stresses and slippage of the joint when loaded. NDS•8.1 specifies that bolt holes should range from 1/32 to 1/16 inch larger than the bolt diameter to prevent splitting and to ensure reasonably uniform dowel bearing stresses.

7.2.3 Specialty Connection Hardware

Many manufacturers fabricate specialty connection hardware. The load capacity of a specialty connector usually is obtained through testing to determine the required structural design values. The manufacturer's product catalog typically provides the required values; thus, the designer can select a standard connector based on the design load determined for a particular joint or connection (see chapter 3). The designer should carefully consider the type of fastener to be used with the connector, however; sometimes a manufacturer requires or offers proprietary nails, screws, or other devices. The designer should also verify the safety factor and strength adjustments used by the manufacturer, including the basis of the design value. In some cases, as with nailed and bolted connections in the NDS, the basis is a serviceability limit state (that is, slip or deformation) and not ultimate capacity.

Following is discussion of a few examples of specialty connection hardware, which are illustrated in figure 7.3.

- *Sill anchors* are used in lieu of foundation anchor bolts. Many configurations are available in addition to the one shown in figure 7.3.
- *Joist hangers* are used to attach single or multiple joists to the side of girders or header joists.
- *Rafter clips* and *roof tie-downs* are straps or brackets that connect roof framing members to wall framing to resist roof uplift loads associated with high wind conditions.

- *Hold-down brackets* are brackets that are bolted, nailed, or screwed to wall studs or posts and anchored to the construction below (that is, concrete, masonry, or wood) to “hold down” the end of a member or assembly (that is, shear wall).
- *Strap ties* are prepunched straps or coils of strapping that are used for a variety of connections to transfer tension loads.
- *Splice plates* or *shear plates* are flat plates with prepunched holes for fasteners to transfer shear or tension forces across a joint.
- *Epoxy-set anchors* are anchor bolts that are drilled and installed with epoxy adhesives into concrete after the concrete has cured and sometimes after the framing is complete so that the required anchor location is obvious.

FIGURE 7.3

Specialty Connector Hardware

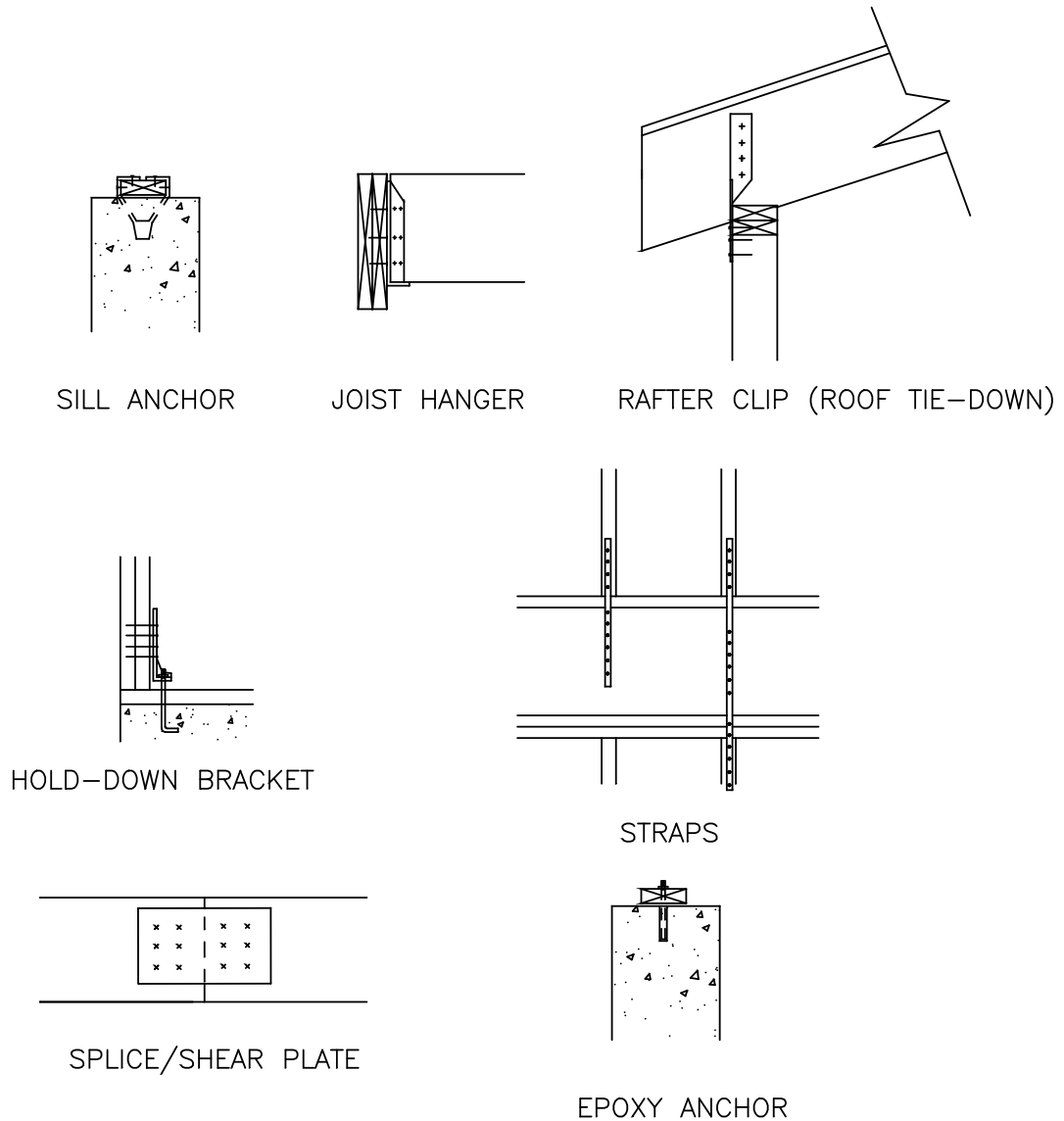

7.2.4 Lag Screws

Lag screws are available in the same diameter range as bolts; the principal difference between the two types of connectors is that a lag screw has screw threads that taper to a point. The threaded portion of the lag screw anchors itself in the main member that receives the tip. Lag screws (often called lag bolts)

function as bolts in joints where the main member is too thick to be economically penetrated by regular bolts. They are also used when one face of the member is not accessible for a “through-bolt.” Holes for lag screws must be carefully drilled to one diameter and depth for the shank of the lag screw and to a smaller diameter for the threaded portion. Self-tapping lag screws, which do not require a pilot hole to be drilled, are now on the market. These lag screws also can have higher yield strengths to improve shear resistance. Lag screws in residential applications generally are small in diameter and may be used to attach garage door tracks to wood framing, steel angles to wood framing supporting brick veneer over wall openings, various brackets or steel members to wood, and wood ledgers to wall framing.

7.3 Wood Connection Design

7.3.1 General

This section covers the NDS design procedures for nails, bolts, and lag screws. The procedures are intended for allowable stress design (ASD) such that loads should be determined accordingly (see chapter 3). Other types of fastenings are addressed by the NDS, but they are rarely used in residential wood construction. The applicable sections of the NDS related to connection design as covered in this chapter include—

- NDS•7—Mechanical Connections (General Requirements).
- NDS•8—Bolts.
- NDS•9—Lag Screws.
- NDS•12—Nails and Spikes.

Although wood connections generally are responsible for the complex, nonlinear behavior of wood structural systems, the design procedures outlined in the NDS are straightforward. The NDS connection values generally are conservative from a structural safety standpoint. Further, the NDS’s basic or tabulated design values are associated with tests of single fasteners in standardized conditions. As a result, the NDS provides several adjustments to account for various factors that alter the performance of a connection; in particular, the performance of wood connections is highly dependent on the species (that is, density or specific gravity) of wood. Table 7.2 provides the specific gravity values of various wood species typically used in house construction.

TABLE 7.2***Common Framing Lumber Species and Specific Gravity Values***

Lumber Species	Specific Gravity, G
Southern pine (SP)	0.55
Douglas-Fir-Larch (DF-L)	0.50
Hem-Fir (HF)	0.43
Spruce-Pine-Fir (SPF)	0.42
Spruce-Pine-Fir (South)	0.36

The moisture condition of the wood also is critical to long-term connection performance, particularly for nails during withdrawal. In some cases, the withdrawal value of fasteners installed in moist lumber can decrease by as much as 50 percent over time, as the lumber dries to its equilibrium moisture content. At the same time, a nail may develop a layer of rust that increases withdrawal capacity. In contrast, deformed shank nails tend to hold their withdrawal capacity much more reliably under varying moisture and use conditions. For this and other reasons, the design nail withdrawal capacities in the NDS for smooth shank nails are based on a fairly conservative reduction factor, resulting in about one-fifth of the average ultimate tested withdrawal capacity. The reduction includes a safety factor as well as a load duration adjustment (that is, decreased by a factor of 1.6 to adjust from short-term tests to a normal duration load). Design values for nails and bolts in shear are based on a deformation (that is, slip) limit state, not their ultimate capacity, resulting in a safety factor that may range from 3 to 5, based on ultimate tested capacities. One argument for retaining a high safety factor in shear connections is that the joint may creep under long-term load. Although creep is not a concern for many joints, slip of joints in a trussed assembly (such as a rafter-ceiling joist roof framing) is critical and, in key joints, can result in a magnified deflection of the assembly over time (that is, creep).

As the preceding discussion indicates, a number of uncertainties in the design of connections can lead to conservative or unconservative designs relative to the intent of the NDS and practical experience. The designer is advised to follow the NDS procedures carefully but should be prepared to make practical adjustments as dictated by sound judgment and experience and allowed in the NDS (refer to NDS•7.1.1.4).

Withdrawal design values for nails and lag screws in the NDS are based on the fastener being oriented perpendicular to the grain of the wood. Shear design values in wood connections also are based on the fastener being oriented perpendicular to the grain of wood; however, the lateral (shear) design values are dependent on the direction of loading relative to the wood grain direction in each of the connected members. Figure 7.4 illustrates various connection types and loading conditions.

FIGURE 7.4

Types of Connections and Loading Conditions

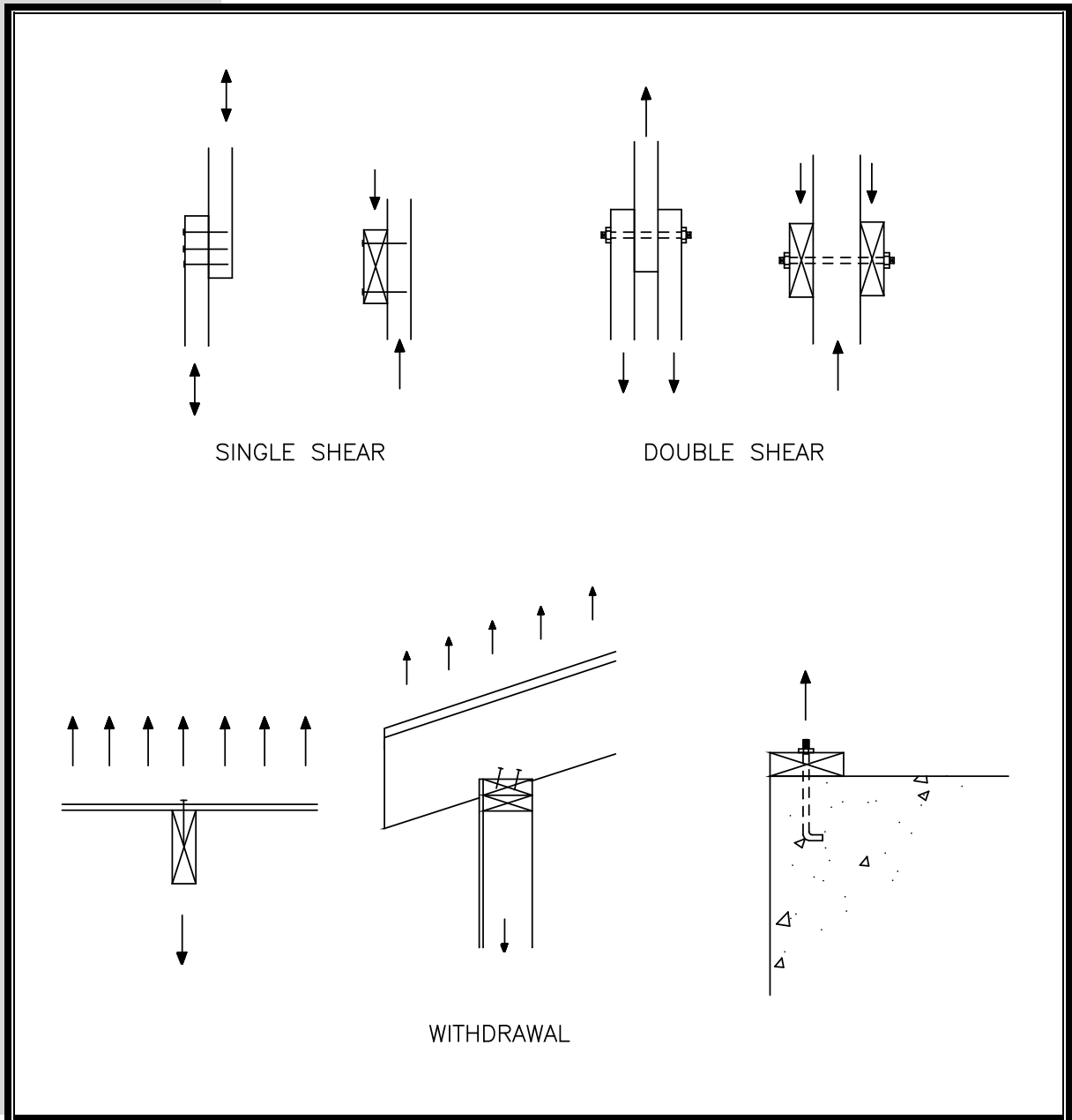

The NDS provides tabulated connection design values that use the following symbols for the three basic types of loading.

- W—withdrawal (or tension loading).
- Z_{\perp} —shear perpendicular to wood grain.
- Z_{\parallel} —shear parallel to wood grain.

In addition to the already tabulated design values for the preceding structural resistance properties of connections, the NDS provides calculation methods to address conditions that may not be covered by the tables and that give more flexibility to the design of connections. The methods are appropriate for use in hand calculations or with computer spreadsheets.

For withdrawal, the design equations are relatively simple empirical relationships (based on test data) that explain the effect of fastener size (diameter), penetration into the wood, and density of the wood. For shear, the equations are somewhat more complex because of the multiple failure modes that may result from fastener characteristics, wood density, and size of the wood members. Six shear-yielding modes (and a design equation for each) address various yielding conditions in either the wood members or the fasteners that join the members. The critical yield mode is used to determine the design shear value for the connection (refer to NDS•appendix I for a description of the yield modes).

The yield equations in the NDS are based on general dowel equations that use principles of engineering mechanics to predict the shear capacity of a doweled joint. The general dowel equations can be used with joints that have a gap between the members, and they can also be used to predict ultimate capacity of a joint made of wood, wood and metal, or wood and concrete (AWC, 2014). The equations do not account for friction between members, however, or for the anchoring or cinching effect of the fastener head as the joint deforms and the fastener rotates or develops tensile forces. These effects are important to the ultimate capacity of wood connections in shear; therefore, the general dowel equations may be considered to be conservative (refer to section 7.3.6). For additional guidance and background on the use of the general dowel equations, refer to the NDS *Commentary* and other useful design resources available through the American Wood Council (AWC, 2012; Showalter, Line, and Douglas, 1999).

7.3.2 Adjusted Allowable Design Values

Design values for wood connections are subject to adjustments in a manner similar to that required for wood members themselves (see section 5.2.4 of chapter 5). The calculated or tabulated design values for W and Z are multiplied by the applicable adjustment factors to determine adjusted allowable design values, W' and Z' , as shown in the following extract from the NDS, for the various connection methods (that is, nails, bolts, and lag screws).

NDS•12.3 & 7.3

$$Z' = ZC_D C_M C_t C_g C_{\Delta} \quad \text{for bolts.}$$

$$Z' = ZC_D C_M C_t C_g C_{\Delta} C_d C_{eg} \quad \text{for lag screws.}$$

$$Z' = ZC_D C_M C_t C_d C_{eg} C_{di} C_{tn} \quad \text{for nails and spikes.}$$

NDS•12.2 & 7.3

$$W' = WC_D C_M C_t C_{tn} \quad \text{for nails and spikes.}$$

$$W' = WC_D C_M C_t C_{eg} \quad \text{for lag screws.}$$

The adjustment factors and their applicability to wood connection design are briefly described as follows.

- C_D —*Load Duration Factor* (NDS•2.3.2 and chapter 5, table 5.2)—applies to W and Z values for all fasteners, based on design load duration, but shall not exceed 1.6 (that is, wind and earthquake load duration factor).
- C_M —*Wet Service Factor* (NDS•7.3.3)—applies to W and Z values for all connections based on moisture conditions at the time of fabrication and during service; not applicable to residential framing.
- C_t —*Temperature Factor* (NDS•7.3.4)—applies to the W and Z values for all connections exposed to sustained temperatures of greater than 100°F; not typically used in residential framing.
- C_g —*Group Action Factor* (NDS•7.3.6)—applies to Z values of two or more bolts or lag screws loaded in single or multiple shear and aligned in the direction of the load (that is, rows).
- C_A —*Geometry Factor* (NDS•8.5.2, 9.4.)—applies to the Z values for bolts and lag screws when the end distance or spacing of the bolts is less than assumed in the unadjusted design values.
- C_d —*Penetration Depth Factor* (NDS•9.3.3, 12.3.4)—applies to the Z values of lag screws and nails when the penetration into the main member is less than 8D for lag screws or 12D for nails (where D = shank diameter); sometimes applicable to residential nailed connections.
- C_{eg} —*End Grain Factor* (NDS•9.2.2, 9.3.4, 12.3.5)—applies to W and Z values for lag screws and to Z values for nails to account for reduced capacity when the fastener is inserted into the end grain ($C_{eg} = 0.67$).
- C_{di} —*Diaphragm Factor* (NDS•12.3.6)—applies to the Z values of nails only to account for system effects from multiple nails used in sheathed diaphragm construction ($C_{di} = 1.1$).
- C_{tn} —*Toenail Factor* (NDS•12.3.7)—applies to the W and Z values of toenailed connections ($C_{tn} = 0.67$ for withdrawal and = 0.83 for shear). It does not apply to slant nailing in withdrawal or shear; refer to section 7.3.6.

The total allowable design value for a connection (as adjusted by the appropriate factors above) must meet or exceed the design load determined for the connection (refer to chapter 3 for design loads). The values for W and Z are based on single fastener connections. In instances of connections involving multiple fasteners, the values for the individual or single fastener can be summed to determine the total connection design value only when C_g is applied (to bolts and

lag screws only) and fasteners are the same type and similar size. This approach may overlook certain system effects that can improve the actual performance of the joint in a constructed system or assembly, however (see section 7.3.6). Conditions that may decrease estimated performance, such as prying action induced by the joint configuration or eccentric loads and other factors, should also be considered.

In addition, the NDS does not provide values for nail withdrawal or shear when wood structural panel members (that is, plywood or oriented strand board) are used as a part of the joint. This type of joint—wood member to structural wood panel—occurs frequently in residential construction. Z values can be estimated by using the yield equations for nails in NDS 12.3.1 and assuming a reasonable specific gravity (density) value for the wood structural panels, such as $G = 0.5$. W values for nails in wood structural panels can be estimated in a similar fashion by using the withdrawal equation presented in the next section. The tabulated W and Z values in NDS•12 may also be used but with some caution as to the selected table parameters.

7.3.3 Nailed Connections

The procedures in NDS•12 provide for the design of nailed connections to resist shear and withdrawal loads in wood-to-wood and metal-to-wood connections. As mentioned, many specialty “nail-type” fasteners are available for wood-to-concrete and even wood-to-steel connections. The designer should consult manufacturer data for connection designs that use proprietary fastening systems.

The withdrawal strength of a smooth nail (driven into the side grain of lumber) is determined in accordance with either the empirical design equation that follows or NDS•table 12.2A.

NDS•12.2.1

$$W = 1380(G)^{\frac{5}{2}} DL_p \quad \text{unadjusted withdrawal design value (lb) for a smooth shank nail.}$$

where,

G = specific gravity of the lumber member receiving the nail tip.

D = the diameter of the nail shank (in).

L_p = the depth of penetration (in) of the nail into the member receiving the nail tip.

The design strength of nails is greater when a nail is driven into the side rather than the end grain of a member. Withdrawal information is available for nails driven into the side grain; however, the withdrawal capacity of a nail driven into the end grain is assumed to be zero because of its unreliability. Furthermore, the NDS does not provide a method for determining withdrawal values for deformed shank nails. These nails significantly enhance withdrawal capacity and are frequently used to attach roof sheathing in high-wind areas. They also are used to attach floor sheathing and some siding materials to prevent nail “back-out.” The use of deformed shank nails usually is based on experience or preference.

Withdrawal values for deformed shank nails are provided in ICC-ES Report 1539 (ICC-ES, 2013) on pneumatically driven fasteners.

The design shear value, Z , for a nail typically is determined using the following tables from NDS•12.

- *Tables 12.3A and B.* Nailed wood-to-wood, single-shear (two-member) connections with the same species of lumber using box or common nails, respectively.
- *Tables 12.3E and F.* Nailed metal plate-to-wood connections using box or common nails, respectively.

The yield equations in NDS•12.3 may be used for conditions not represented in the design value tables for Z . Regardless of the method used to determine the Z value for a single nail, the value must be adjusted as described in section 7.3.2. As noted in the NDS, the single nail value is used to determine the design value.

It is also worth mentioning that the NDS provides an equation for determining allowable design value for shear when a nailed connection is loaded in combined withdrawal and shear (see NDS•12.3.8, equation 12.3-6). The equation appears to be most applicable to a gable-end truss connection to the roof sheathing under conditions of roof sheathing uplift and wall lateral load owing to wind. The designer might contemplate other applications but should take care in considering the combination of loads that would be necessary to create simultaneous uplift and shear worthy of a special calculation.

7.3.4 Bolted Connections

Bolts may be designed in accordance with NDS•8 to resist shear loads in wood-to-wood, wood-to-metal, and wood-to-concrete connections. As mentioned, many specialty “bolt-type” fasteners can be used to connect wood to other materials, particularly concrete and masonry. One common example is an epoxy-set anchor. Manufacturer data should be consulted for connection designs that use proprietary fastening systems.

The design shear value Z for a bolted connection is typically determined by using the following tables from NDS•8.

- Table 8.2A. Bolted wood-to-wood, single-shear (two-member) connections with the same species of lumber.
- Table 8.2B. Bolted metal plate-to-wood, single-shear (two-member) connections; metal plate thickness of 1/4 inch minimum.
- Table 8.2D. Bolted single-shear wood-to-concrete connections; based on minimum 6-inch bolt embedment in minimum $f_c = 2,000$ psi concrete.

The yield equations of NDS•8.2 (single-shear joints) and NDS•8.3 (double-shear joints) may be used for conditions not represented in the design value tables. Regardless of the method used to determine the Z value for a single bolted connection, the value must be adjusted as described in section 7.3.2.

It should be noted that the NDS does not provide W values for bolts. The tension value of a bolt connection in wood framing is usually limited by the bearing capacity of the wood as determined by the surface area of a washer used underneath the bolt head or nut. When calculating the bearing capacity of the wood based on the tension in a bolted joint, the designer should use the small bearing area value C_b to adjust the allowable compressive stress perpendicular to grain $F_{c\perp}$ (see NDS•2.3.10). It should also be remembered that the allowable compressive stress of lumber is based on a deformation limit state, not capacity; refer to section 5.2.3 of chapter 5. In addition, the designer should verify the tension capacity of the bolt and its connection to other materials (that is, concrete or masonry, as covered in section 7.4). The bending capacity of the washer should also be considered. For example, a wide but thin washer will not evenly distribute the bearing force to the surrounding wood.

The arrangement of bolts and drilling of holes are extremely important to the performance of a bolted connection. The designer should carefully follow the minimum edge, end, and spacing requirements of NDS•8.5. When necessary, the designer should adjust the design value for the bolts in a connection by using the geometry factor C_{Δ} and the group action factor C_g discussed in section 7.3.2.

Any possible torsional load on a bolted connection (or any connection for that matter) should also be considered in accordance with the NDS. In such conditions, the pattern of the fasteners in the connection can become critical to performance in resisting both a direct shear load and the loads created by a torsional moment on the connection. Fortunately, this condition is not often applicable to typical light-frame construction. However, cantilevered members that rely on connections to “anchor” the cantilevered member to other members will experience this effect, and the fasteners closest to the cantilever span will experience greater shear load. One example of this condition sometimes occurs with balcony construction in residential buildings; failure to consider the effect discussed above has been associated with some notable balcony collapses.

For wood members bolted to concrete, the design lateral values are provided in NDS•table 8.2E. The yield equations (or general dowel equations) may also be used to conservatively determine the joint capacity. A recent study has made recommendations regarding reasonable assumptions that must be made in applying the yield equations to bolted wood-to-concrete connections (Stieda, 1999). Using symbols defined in the NDS, the study recommends an R_e value of 5 and an R_t value of 3. These assumptions are reported as being conservative because fastener head effects and joint friction are ignored in the general dowel equations.

7.3.5 Lag Screws

Lag screws (or lag bolts) may be designed to resist shear and withdrawal loads in wood-to-wood and metal-to-wood connections in accordance with NDS•9. As mentioned, many specialty “screw-type” fasteners can be installed in wood. Some tap their own holes and do not require predrilling. Manufacturer data should be consulted for connection designs that use proprietary fastening systems.

The withdrawal strength of a lag screw (inserted into the side grain of lumber) is determined in accordance with either the empirical design equation below or NDS•table 9.2A. It should be noted that the equation below is based on single lag screw connection tests and is associated with a reduction factor of 0.2 applied to average ultimate withdrawal capacity to adjust for load duration and safety. Also, the penetration length of the lag screw L_p into the main member does not include the tapered portion at the point. NDS•appendix L contains dimensions for lag screws.

NDS•9.2.1

$$W = 1800(G)^{\frac{3}{2}} D^{\frac{3}{4}} L_p \quad \text{unadjusted withdrawal design value (lb) for a lag screw.}$$

where,

G = specific gravity of the lumber receiving the lag screw tip.

D = the diameter of the lag screw shank (in).

L_p = the depth of penetration (in) of the lag screw into the member receiving the tip, less the tapered length of the tip.

The allowable withdrawal design strength of a lag screw is greater when the screw is installed in the side rather than the end grain of a member. However, unlike the treatment of nails, the withdrawal strength of lag screws installed in the end grain may be calculated by using the C_{eg} adjustment factor with the equation above.

The design shear value Z for a lag screw is typically determined by using the following tables from NDS•9:

- Table 9.3A. Lag screw, single-shear (two-member) connections with the same species of lumber for both members.
- Table 9.3B. Lag screw and metal plate-to-wood connections.

The yield equations in NDS•9.3 may be used for conditions not represented in the design value tables for Z . Regardless of the method used to determine the Z value for a single lag screw, the value must be adjusted as described in section 7.3.2.

Also worth mentioning is that the NDS provides an equation for determining the allowable shear design value when a lag screw connection is loaded in combined withdrawal and shear (see NDS•9.3.5, equation 9.3-6). The

equation does not, however, seem to apply to typical uses of lag screws in residential construction.

7.3.6 System Design Considerations

As with any building code or design specification, the NDS provisions may not address all conditions encountered in the field. Earlier chapters made several recommendations regarding alternative or improved design approaches. Similarly, some considerations regarding wood connection design are in order.

First, as a general design consideration, “crowded” connections should be avoided. If too many fasteners are used (particularly nails), they may cause splitting during installation. When connections become crowded, an alternative fastener or connection detail should be considered. Basically, the connection detail should be practical and efficient.

Second, although the NDS addresses “system effects” within a particular joint (that is, element) that uses multiple bolts or lag screws (that is, the group action factor C_g), it does not include provisions regarding the system effects of multiple joints in an assembly or system of components. Some consideration of system effects is given below, therefore, based on several relevant studies related to key connections in a home that allow the dwelling to perform effectively as a structural unit.

Sheathing Withdrawal Connections

Several studies have focused on roof sheathing attachment and nail withdrawal, primarily as a result of Hurricane Andrew (Cunningham, 1993; HUD, 1999b; McLain, 1997; Mizzell and Schiff, 1994; and Murphy, Pye, and Rosowsky, 1995). The studies identify problems related to predicting the pull-off capacity of sheathing based on single nail withdrawal values and determining the tributary withdrawal load (that is, wind suction pressure) on a particular sheathing fastener. One clear finding, however, is that the nails on the interior of the roof sheathing panels are the critical fasteners (that is, they initiate panel withdrawal failure) because of the generally larger tributary area served by these fasteners. The studies also identified benefits to the use of screws and deformed shank nails; however, use of a standard geometric tributary area of the sheathing fastener and the wind loads, as described in chapter 3, along with the NDS withdrawal values (section 7.3.3), will generally result in a reasonable design using nails. The wind load duration factor should also be applied to adjust the withdrawal values because a commensurate reduction is implicit in the design withdrawal values relative to the short-term, tested, ultimate withdrawal capacities.

One study, however, found that the lower bound (that is, fifth percentile) sheathing pull-off resistance was considerably higher than that predicted by use of single-nail test values (Murphy, Pye, and Rosowsky, 1995). The difference was as large as a factor of 1.39 greater than the single nail values. Although this finding would suggest a withdrawal system factor of at least 1.3 for sheathing nails, it should be subject to additional considerations. For example, sheathing nails are

placed by people using tools in somewhat adverse conditions (for example, on a roof), not in a laboratory; therefore, this system effect may be best considered as a reasonable “construction tolerance” on actual nail spacing variation relative to that intended by design. Thus, an 8- to 9-inch nail spacing on roof sheathing nails in the panel’s field could be “tolerated” when a 6-inch spacing is “targeted” by design.

Roof-to-Wall Connections

Several studies (Conner, Gromala, and Burgess, 1987; Reed, Rosowsky, and Schiff, 1996) have investigated the capacity of roof-to-wall (that is, sloped rafter to top plate) connections using conventional toenailing and other enhancements (strapping, brackets, and gluing, for example). Again, the primary concern is related to high wind conditions, such as those experienced during hurricane wind events.

First, as a matter of clarification, the toenail reduction factor C_{tn} does not apply to *slant nailing*, such as in rafter-to-wall and floor-to-wall connections in conventional residential construction (Hoyle and Woeste, 1989). Toenailing occurs when a nail is driven at an angle in a direction parallel-to-grain at the end of a member (for example, a wall stud toenail connection to the top or bottom plate that may be used instead of end nailing). Slant nailing occurs when a nail is driven at an angle, but in a direction perpendicular-to-grain through the side of the member and into the face grain of the other (for example, from a roof rafter or floor band joist to a wall top plate). Although a generally reliable connection in most homes and similar structures built in the United States, even a well-designed slant-nail connection used to attach roofs to walls will become impractical in hurricane-prone regions or similar high-wind areas. In these conditions, a metal strap, bracket, or clip is required to resist the high uplift loads induced by these high-wind events.

Based on the studies of roof-to-wall connections, five key findings are summarized, as follows (Conner, Gromala, and Burgess, 1987; Reed, Rosowsky, and Schiff, 1996)—

1. In general, studies found that slant nails (not to be confused with toe nails), in combination with metal straps or brackets, do not provide directly additive uplift resistance.
2. A basic metal twist strap placed on the interior side of the walls (that is, the gypsum board side) resulted in top plate tear-out and premature failure. A strap placed on the outside of the wall (that is, the structural sheathing side), however, was able to develop its full capacity without additional enhancement of the conventional stud-to-top plate connection.
3. The withdrawal capacity for single joints with slant nails was reasonably predicted by NDS with a safety factor of about 2 to 3.5; however, with multiple joints tested simultaneously, a system factor on withdrawal capacity of greater than 1.3 was found for the slant-nailed

rafter-to-wall connection. A similar system effect was not found on strap connections, although the strap capacity was substantially higher. The ultimate capacity of the simple strap connection (using five 8d nails on either side of the strap—five in the spruce rafter and five in the Southern Yellow Pine top plate) was found to be about 1,900 pounds per connection. The capacity of three 8d common slant nails used in the same joint configuration was found to be 420 pounds on average, and with higher variation.

4. The strap manufacturer's published value had an excessive safety margin of greater than 5 relative to average ultimate capacity. Adjusted to an appropriate safety factor in the range of 2 to 3 (as calculated by applying NDS nail shear equations by using a metal side plate), the strap (a simple 18g twist strap) would cover a multitude of high wind conditions with a simple, economical connection detail.
5. The use of deformed shank (that is, annular ring) nails driven in using the slant nailing method was found to increase dramatically the uplift capacity of the roof-to-wall connections.

Heel Joint in Rafter-to-Ceiling Joist Connections

The heel joint connection at the intersection of rafters and ceiling joists has long been considered one of the weaker connections in conventional wood roof framing. In fact, this highly stressed joint is one of the accolades of using a wood truss rather than conventional rafter framing (particularly in high-wind or snow-load conditions). The designer should understand the performance of conventional rafter-to-ceiling joist heel joint connections, however, because they are frequently encountered in residential construction.

Conventional rafter and ceiling joist (cross-tie) framing can be analyzed by using methods that are applicable to trusses (that is, pinned joint analysis); however, the performance of the system should be considered. As mentioned earlier for roof trusses (section 5.6.1 in chapter 5), a system factor of 1.1 is applicable to tension members and connections; therefore, the calculated shear capacity of the nails in the heel joint (and in ceiling joist splices) may be multiplied by a system factor of 1.1, which is considered conservative. Second, the designer must remember that the nail shear values are based on a deformation limit and generally have a conservative safety factor of 3 to 5 relative to the ultimate capacity. Finally, the nail values should be adjusted for duration of load (that is, a snow load duration factor of 1.15 to 1.25); refer to section 5.2.4 of chapter 5. With these considerations and with the use of rafter support braces at or near mid-span (as is common), reasonable heel joint designs should be possible for most typical design conditions in residential construction.

Wall-to-Floor Connections

Many nails often are used to connect wood sole plates to wood floors, particularly along the total length of the sole plate or wall bottom plate. Usually,

several bolts along the length of the bottom plate connect it to a concrete slab or foundation wall. This points toward the question of possible system effects in estimating the shear capacity (and uplift capacity) of these connections for design purposes.

In recent shear wall tests, walls connected with pneumatic nails (0.131-inch diameter by 3 inches long), spaced in pairs at 16 inches on center along the bottom plate, were found to resist more than 600 pounds in shear per nail (HUD, 1999a) (the bottom plate was Spruce-Pine-Fir lumber, and the base beam was Southern Yellow Pine). That value is about 4.5 times the adjusted allowable design shear capacity predicted using the NDS equations. Similarly, connections using 5/8-inch-diameter anchor bolts at 6 feet on center (all other conditions equal) were tested in full shear wall assemblies; the ultimate shear capacity per bolt was found to be 4,400 pounds. That value is about 3.5 times the adjusted allowable design shear capacity per the NDS equations. The designer should consider those safety margins when evaluating similar connections from a practical “system” standpoint; however, compliance with the applicable standards and accepted methodology is still the recommended approach.

7.4 Design of Concrete and Masonry Connections

7.4.1 General

In typical residential construction, the interconnection of concrete and masonry elements or systems is generally related to the foundation and usually handled in accordance with standard or accepted practice. The bolted wood member connections to concrete, as described in section 7.3.4, are suitable for bolted wood connections to properly grouted masonry (see chapter 4). Moreover, numerous specialty fasteners or connectors (including power driven and cast-in-place) can be used to fasten wood materials to masonry or concrete. The designer should consult the manufacturer’s literature for available connectors, fasteners, and design values.

This section discusses some typical concrete and masonry connection designs in accordance with the ACI 318 concrete design specification and ACI 530 masonry design specification (ACI, 2008, 2011).

7.4.2 Concrete or Masonry Foundation Wall to Footing

Footing connections, if any, are intended to transfer shear loads from the wall to the footing below. The shear loads generally are produced by lateral soil pressure acting on the foundation (see chapter 3) or loads in shear walls from wind or seismic events.

Footing-to-wall connections for residential construction often are constructed in one of the following three ways (refer to figure 7.5 for illustrations of the connections)—

- No vertical reinforcement or key.
- Key only.
- Dowel only.

Generally, no special connection is needed in non-hurricane-prone or low-to moderate-hazard seismic areas. Friction is sufficient for low, unbalanced backfill heights, whereas the basement slab can resist slippage for higher backfill heights on basement walls. The basement slab abuts the basement wall near its base and thus provides lateral support. If gravel footings are used, the unbalanced backfill height must be sufficiently low (that is, less than 3 feet), or means must be provided to prevent the foundation wall from slipping sideways from lateral soil loads. Again, a basement slab can provide the needed support. Alternatively, a footing key or doweled connection can be used. In spite of the many probable locations across the country where no physical connection might be required between the foundation wall and the footing, the best practice remains to attach these two elements. Without the physical connection, this critical part of the load path arguably is not continuous. Often, problems arise that could have been reduced or eliminated if a physical connection had existed between the foundation wall and footing. This is particularly true when any extreme loading occurs, such as high winds or even a moderate earthquake.

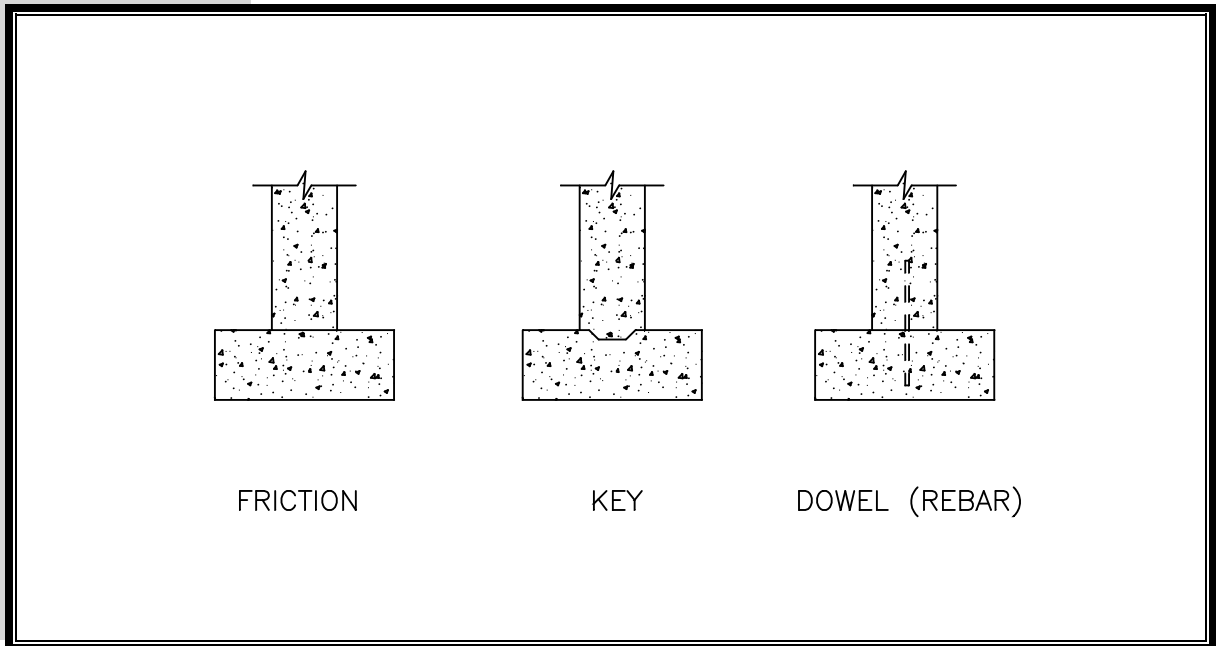
FIGURE 7.5***Concrete or Masonry Wall-to-Footing Connections******Friction Used To Provide Shear Transfer***

To verify the amount of shear resistance provided by friction alone, the designer should assume a coefficient of friction between two concrete surfaces of $\mu = 0.6$. Using dead loads only, determine the static friction force, $F = \mu NA$, where F is the friction force (pounds), N is the dead load (pounds per square foot), and A is the bearing surface area (square feet) between the wall and the footing. The appropriate load combination must be used in determining the resistance permitted for the dead load.

Key Used To Provide Shear Transfer

A concrete key is commonly used to “interlock” foundation walls to footings. If foundation walls are constructed of masonry, the first course of masonry must be grouted solid when a key is used.

In residential construction, builders often form a key by using a 2x4 wood board with chamfered edges and placing it into the surface of the footing immediately after the concrete pour. Figure 7.6 illustrates a footing with a key; shear resistance developed by the key is computed in accordance with the following equation.

ACI-318•22.5

$$V_u \leq \phi V_n .$$

ACI-318•22.5

$$V_n = \frac{4}{3} \sqrt{f'_c} b h .$$

FIGURE 7.6 *Key in Concrete Footings*

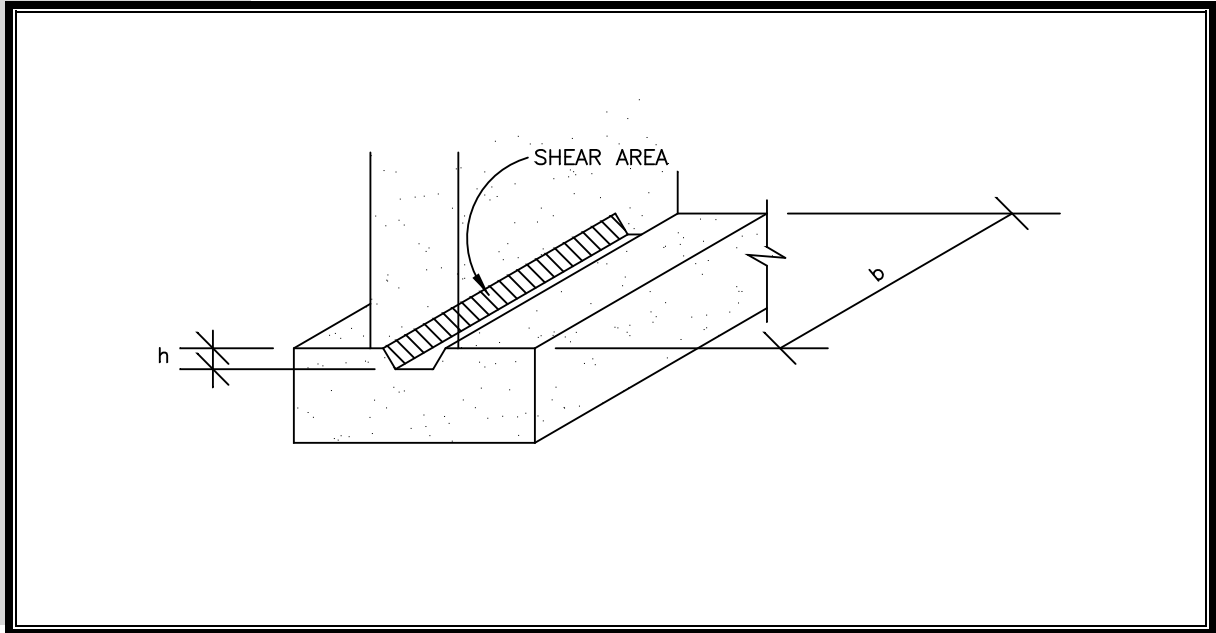

Dowels Used To Provide Adequate Shear Transfer

Shear forces at the base of exterior foundation walls may require a dowel to transfer the forces from the wall to the footing. The designer can use the equations that follow, described by ACI-318 as the Shear-Friction Method, to develop shear resistance with vertical reinforcement (dowels) across the wall-footing interface.

ACI-318•11.7

Masonry Walls

$$l_{be} \geq 12d_b$$

$$B_v = \text{minimum of } \left\{ \begin{array}{l} 350 \sqrt[4]{f'_m A_v} \\ 0.12 A_v f_y \end{array} \right\}$$

$$l_d = \text{maximum } \{ 2d_b \}$$

Concrete Walls

$$V_u \leq \phi V_n$$

$$V_n = A_{vf} f_y \mu \leq \left\{ \begin{array}{l} 0.2 f'_c A_c \\ 800 A_c \end{array} \right\}$$

$$A_{vf} = \frac{V_u}{\phi f_y \mu}$$

$$\phi = 0.85$$

If dowels are used to transfer shear forces from the base of the wall to the footing, the designer can use the equations below to determine the minimum

development length required (refer to figure 7.7 for typical dowel placement). If development length exceeds the footing thickness, the dowel must be in the form of a hook, which usually is not required in residential construction except in high-wind or high-seismic regions or where the foundation wall will resist deep backfill or will likely be subject to hydrostatic pressure.

ACI-318•12.2 & 12.5

Concrete Walls

Standard Hooks

$$l_{hb} = \frac{1200d_b}{\sqrt{f'_c}} \quad \text{where } f_y = 60,000 \text{ psi}$$

Deformed Bars

$$l_{db} = \left(\frac{3f_y}{40\sqrt{f'_c}} \right) \left(\frac{\alpha\beta\gamma\lambda}{c + K_{TR}} \right) \left(\frac{d_b}{d_b} \right)$$

$$\frac{c + K_{TR}}{d_b} \leq 2.5$$

$$l_d = l_{db} \left(\frac{A_{s,required}}{A_{s,provided}} \right) \geq 12''$$

$$\xi = \frac{f_y}{60,000}$$

$$\omega = \frac{A_{s,required}}{A_{s,provided}}$$

ACI-530•1.12.3 & 2.1.8

Masonry Walls

Standard Hooks

$$l_d = 0.0015d_b F_s \geq 12 \text{ in.}$$

$$l_e = 11.25d_b$$

FIGURE 7.7

Dowel Placement in Concrete Footings

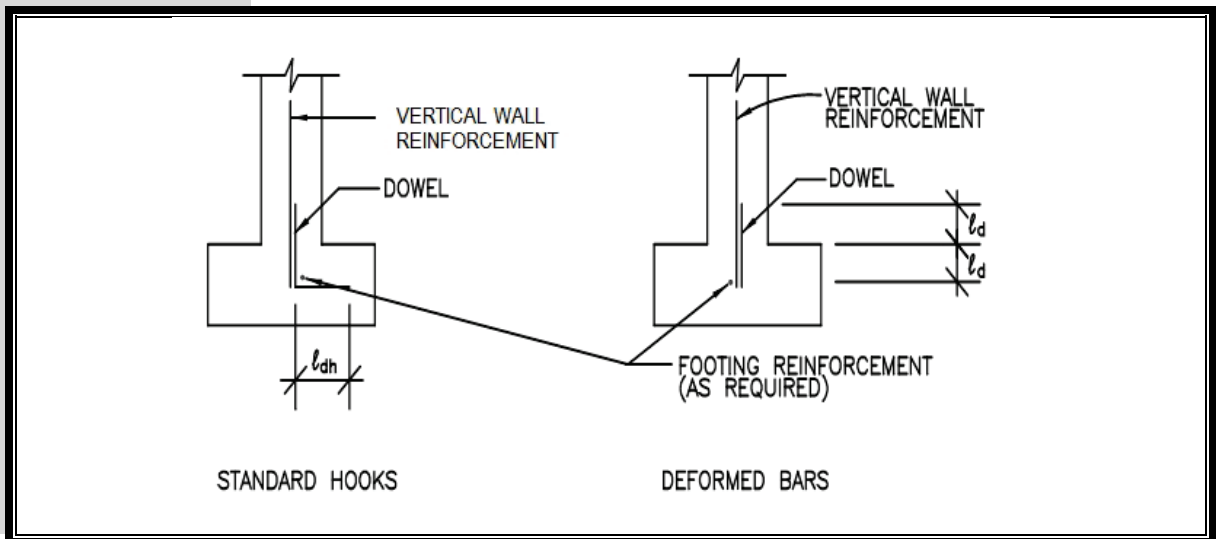

The minimum embedment length is a limit specified in ACI-318 that is not necessarily compatible with residential construction conditions and practice; therefore, this guide suggests a minimum embedment length of 6 to 8 inches for

footing dowels, when necessary, in residential construction applications. In addition, dowels sometimes are used in residential construction to connect other concrete elements, such as porch slabs or stairs, to the house foundation to control differential movement. Exterior concrete “flat work” adjacent to a home, however, should be founded on adequate soil bearing or reasonably compacted backfill. Finally, connecting exterior concrete work to the house foundation requires caution, particularly in colder climates and soil conditions where frost heave may be a concern.

7.4.3 Anchorage and Bearing on Foundation Walls

In addition to the references noted herein, appendix D of ACI 318 is devoted to anchoring to concrete and provides substantial information for the designer on both shear and tension designs for anchors in concrete.

Anchorage Tension (Uplift) Capacity

The equations that follow determine whether the concrete or masonry shear area of each bolt is sufficient to resist pull-out from the wall as a result of uplift forces and shear friction in the concrete.

ACI-318•11.3 & ACI-530•2.1.2

Concrete Foundation Wall

$$V_u \leq \phi V_c$$

$$V_c = 4A_v \sqrt{f'_c}$$

Masonry Foundation Wall

$$b_a \leq B_a$$

$$B_a = \text{minimum of } \left\{ \begin{array}{l} 0.5A_p \sqrt{f'_m} \\ 0.2A_b f_y \end{array} \right\}$$

Bearing Strength

Determining the adequacy of the bearing strength of a foundation wall follows ACI-318•10.17 for concrete or ACI-530•2.1.7 for masonry. The bearing strength of the foundation wall typically is adequate for the loads encountered in residential construction.

ACI-318•10.17 & ACI-530•2.1.7

Concrete Foundation Wall

B_c = factored bearing load

$$B_c \leq \phi 0.85 f'_c A_1$$

$$\phi = 0.7$$

Masonry Foundation Wall

$$f_a \leq F_a$$

$$f_a = \frac{P}{A_1}$$

$$F_a \leq 0.25 f'_m$$

When the foundation wall's supporting surface is wider on all sides than the loaded area, the designer may determine the design bearing strength on the loaded area using the following equations.

ACI-318•10.7 & ACI-530•2.1.7

Concrete Foundation Wall

$$B_c = \phi 0.85 f'_c A_1 \sqrt{\frac{A_2}{A_1}} \quad \text{where } \sqrt{\frac{A_2}{A_1}} \leq 2$$

Masonry Foundation Wall

$$f_a = \frac{P}{A_1 \sqrt{A_2/A_1}} \quad \text{where } \sqrt{\frac{A_2}{A_1}} \leq 2$$

7.5 Design Examples

EXAMPLE 7.1

Roof Sheathing Connection

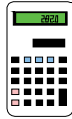

- Given**
- Design wind speed is 130 mph gust with an open (coastal) exposure.
 - Two-story home with a gable roof
 - Roof framing lumber is Southern Yellow Pine ($G=0.55$)
 - Roof framing is spaced at 24 inches on center
 - Roof sheathing is 7/16-inch-thick structural wood panel

Find Wind load (suction) on roof sheathing.
Nail type/size and maximum spacing.

Solution

1. Determine the wind load on roof sheathing (chapter 3, section 3.6.2)

Step 1: Basic velocity pressure = 26 psf (table 3.8)
Step 2: Adjust for open exposure = $1.4(26 \text{ psf}) = 36.4 \text{ psf}$
Step 3: Skip
Step 4: Roof sheathing G_{cp} = -2.2 (table 3.10)
Step 5: Design load = $(-2.2)(36.4 \text{ psf}) = 80 \text{ psf}$

2. Select a trial nail type and size, determine withdrawal capacity, and calculate required spacing.

Use an 8d pneumatic nail (0.113 inch diameter) with a length of 2 3/8 inches. The unadjusted design withdrawal capacity is determined using the equation in section 7.3.3.

$$W = 1380(G)^{2.5}DL_p$$

$$G = 0.55$$

$$D = 0.113 \text{ in}$$

$$L_p = (2 \frac{3}{8} \text{ in}) - (7/16 \text{ in}) = 1.9 \text{ in}$$

$$W = 1380(0.55)^{2.5}(0.113 \text{ in})(1.9 \text{ in}) = 66.5 \text{ lb}$$

Determine the adjusted design withdrawal capacity using the applicable adjustment factors discussed in section 7.3.2.

$$W' = WC_D = (66.5 \text{ lb})(1.6) = 106 \text{ lb}$$

Determine the required nail spacing in the roof sheathing panel interior.

$$\begin{aligned} \text{Tributary sheathing area} &= (\text{roof framing spacing})(\text{nail spacing}) \\ &= (2 \text{ ft})(s) \end{aligned}$$

$$\begin{aligned} \text{Withdrawal load per nail} &= (\text{wind uplift pressure})(2 \text{ ft})(s) \\ &= (80 \text{ psf})(2 \text{ ft})(s) \end{aligned}$$

$$W' \geq \text{design withdrawal load}$$
$$106 \text{ lb} \geq (80 \text{ psf})(2 \text{ ft})(s)$$
$$s \leq 0.66 \text{ ft}$$

Use a maximum nail spacing of 6 inches in the roof sheathing panel interior.

Notes:

1. If Spruce-Pine-Fir ($G=0.42$) roof framing lumber is substituted, W' would be 54 lb, and the required nail spacing would reduce to 4 inches on center in the roof sheathing panel interior. Thus, carefully considering and verifying the species of framing lumber is extremely important when determining fastening requirements for roof sheathing.
2. The preceding analysis is based on a smooth shank nail. A ring shank nail may be used to provide greater withdrawal capacity that also is less susceptible to lumber moisture conditions at installation and related long-term effects on withdrawal capacity.
3. With the smaller tributary area, the roof sheathing edges that are supported on framing members may be fastened at the standard 6-inch on center fastener spacing. For simplicity, the designer may want to specify a 6-inch on center spacing for all roof sheathing fasteners.
4. As an added measure, given the extreme wind environment, the sheathing nail spacing along the gable end truss or framing should be specified at a closer spacing, say, 4 inches on center. These fasteners are critical to the performance of light-frame gable roofs in extreme wind events; refer to the discussion on hurricanes in chapter 1. NDS•12.3.8 provides an equation to determine nail lateral strength when subjected to a combined lateral and withdrawal load. This equation may be used to verify the 4-inch nail spacing recommendation at the gable end.

Conclusion This example problem demonstrates a simple application of the nail withdrawal equation in the NDS. The withdrawal forces on connections in residential construction usually are of greatest concern in the roof sheathing attachment. In hurricane-prone regions, common practice is to use 6-inch nail spacing on the interior of roof sheathing panels.

**Given**

- Design wind speed is 120 mph gust with an open coastal exposure.
- One-story home with a hip roof (28 ft clear span trusses with 2 ft overhangs).
- Roof slope is 6:12.
- Trusses are spaced at 24 in on center.

Find

1. Uplift and transverse shear load at the roof-to-wall connection.
2. Connection detail to resist the design loads.

Solution

1. Determine the design loads on the connection (chapter 3).

Dead load (section 3.3)

$$\begin{aligned} \text{Roof dead load} &= 15 \text{ psf} && \text{(table 3.2)} \\ \text{Dead load on wall} &= (15 \text{ psf})[0.5(28 \text{ ft}) + 2 \text{ ft}] = 240 \text{ plf} \end{aligned}$$

Wind load (section 3.6)

$$\begin{aligned} \text{Step 1: Basic velocity pressure} &= 18 \text{ psf} && \text{(table 3.8)} \\ \text{Step 2: Adjust for open exposure} &= 1.4(18 \text{ psf}) = 25.2 \text{ psf} \\ \text{Step 3: Skip} &&& \\ \text{Step 4: Roof uplift } G_{cp} &= -0.8 \\ \text{Overhang } G_{cp} &= +0.8 \\ \text{Step 5: Roof uplift pressure} &= -0.8(25.2 \text{ psf}) = -20 \text{ psf} \\ \text{Overhang pressure} &= 0.8(25.2 \text{ psf}) = 20 \text{ psf} \end{aligned}$$

Determine the wind uplift load on the wall.

$$\begin{aligned} \text{Design load on wall} &= 0.6D + 0.6W_u && \text{(table 3.1)} \\ &= 0.6(240 \text{ plf}) + 0.6\{(-20 \text{ psf})[0.5(28 \text{ ft}) + 2 \text{ ft}] - (20 \text{ psf})(2 \text{ ft})\} \\ &= -72 \text{ plf (upward)} \end{aligned}$$

$$\text{Design load per wall-to-truss connection} = (2 \text{ ft})(-72 \text{ plf}) = -144 \text{ lb (upward)}$$

Determine the transverse shear (lateral) load on the roof-to-wall connection. The transverse load is associated with the role of the roof diaphragm in supporting and transferring lateral loads from direct wind pressure on the walls.

$$\begin{aligned} \text{Design lateral load on the wall-to-truss connection} \\ &= 1/2 (\text{wall height})(\text{wall pressure})(\text{truss spacing}) \end{aligned}$$

$$\begin{aligned} \text{Adjusted velocity pressure} &= 25.2 \text{ psf} \\ \text{Wall } G_{cp} &= -1.2, +1.1^* \\ \text{Wind pressure} &= 1.1(25.2 \text{ psf}) = 28 \text{ psf} \end{aligned}$$

*The 1.1 coefficient is used because the maximum uplift on the roof and roof overhang occurs on a windward side of the building (that is, positive wall pressure).

$$= 1/2 (8 \text{ ft})(28 \text{ psf})(2 \text{ ft}) = 224 \text{ lb}$$

Thus, roof-to-wall connection combined design loads are as follows.

144 lb (uplift)

224 lb (lateral, perpendicular to wall)*

*The lateral load parallel to a wall is not considered to be significant in this example problem, although it may be checked to verify the transfer of lateral wind loads on the roof to shear walls; refer to chapter 6.

2. Determine a roof-to-wall connection detail to resist the combined design load.

Generally, manufacturers publish loading data for metal connectors for multiple loading directions. The designer should verify that these values are for simultaneous, multidirectional loading or make reasonable adjustments as needed. In this example problem, the NDS will be used to design a simple roof tie-down strap and slant nail connection. A tie-down strap will be used to resist the uplift load, and typical slant nailing will be used to resist the lateral load. The slant nailing, however, does not contribute appreciably to the uplift capacity when a strap or metal connector is used; refer to section 7.3.6.

Uplift load resistance

Assuming an 18g (minimum 0.043 inches thick) metal strap is used, determine the number of 6d common nails required to connect the strap to the truss and to the wall top plate to resist the design uplift load.

The nail shear capacity is determined as follows.

$$\begin{aligned} Z &= 60 \text{ lb} && \text{(NDS table 12.3F)} \\ Z' &= ZC_D && \text{(section 7.3.2)} \\ &= (60 \text{ lb})(1.6) \\ &= 96 \text{ lb} \end{aligned}$$

The number of nails required in each end of the strap is—

$$(144 \text{ lb})/(96 \text{ lb/nail}) = 2 \text{ nails}$$

The above Z value for metal side-plates implicitly addresses failure modes that may be associated with strap/nail head tear-through; however, the width of the strap must be calculated. Assuming a minimum 33 ksi steel yield strength and a standard 0.6 safety factor, the width of the strap is determined as follows.

$$0.6(33,000 \text{ psi})(0.043 \text{ in})(w) = 144 \text{ lb}$$

$$w = 0.17 \text{ in}$$

Therefore, use a minimum 1/2-inch-wide strap to allow for the width of nail holes and a staggered nail pattern.

Lateral load resistance

Assuming that a 16d pneumatic nail will be used (0.131 in diameter by 3.5 inches long), determine the number of slant-driven nails required to transfer the lateral

load from the wall to the roof sheathing diaphragm through the roof trusses. Assume that the wall framing is Spruce-Pine-Fir ($G = 0.42$).

$$Z = 88 \text{ lb} \quad (\text{NDS table 12.3A})^*$$

*A 1 1/4-inch side member thickness is used to account for the slant nail penetration through the truss at an angle.

$$Z' = ZC_D^{**} \quad \text{**The } C_{tn} \text{ value of 0.83 is not used because the nail is slant driven and is not a toe nail; refer to section 7.3.6.}$$

$$Z' = (88 \text{ lb})(1.6) = 141 \text{ lb}$$

Therefore, the number of nails required to transfer the transverse shear load is determined as follows.

$$(224 \text{ lb}) / (141 \text{ lb/nail}) = 2 \text{ nails}$$

Conclusion The beginning of the uplift load path is on the roof sheathing, which is transferred to the roof framing through the sheathing nails; refer to example 7.1. The uplift load is then passed through the roof-to-wall connections, as demonstrated in this example problem. The designer should note that the load path for wind uplift cannot overlook any joint in the framing.

One common error is to attach small roof tie-straps or clips to only the top member of the wall top plate. Thus, the uplift load must be transferred between the two members of the double top plate, which usually are only face-nailed together for assembly, not to transfer large uplift loads. This circumstance would not typically be a problem if the wall sheathing were attached to the top member of the double top plate, but walls usually are built to an 8 ft-1 in height to allow for assembly of interior finishes and to result in a full 8 ft ceiling height after floor and ceiling finishes. Because sheathing is nominally 8 ft in length, it cannot span the full wall height and may not be attached to the top member of the top plate. Also, the strap should be placed on the structural sheathing side of the wall unless framing joints within the wall (that is, stud-to-plates) are adequately reinforced.

Longer sheathing can be special ordered and is often used to transfer uplift and shear loads across floor levels by lapping the sheathing over the floor framing to the wall below. The sheathing may also be laced at the floor band joist to transfer uplift load, but the cross-grain tension of the band joist should not exceed a suitably low stress value (that is, $1/3F_v$); refer to chapter 5, section 5.3.1.

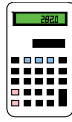
**Given**

- A 2x4 wall bottom (sole) plate of Spruce-Pine-Fir is fastened to a wood floor deck.
- Floor framing lumber is Hem-Fir.
- A 3/4-inch-thick wood structural panel subfloor is used.
- The bottom plate is subject to the following design loads because of wind or earthquake lateral loads—
 - 250 plf shear parallel-to-grain (shear wall slip resistance).
 - 120 plf shear perpendicular-to-grain (transverse load on wall).
- The uplift load on the wall, if any, is assumed to be resisted by other connections (for example, uplift straps, shear wall hold-downs).

Find

A suitable nailing schedule for the wall sole plate connection using 16d pneumatic nails (0.131-inch diameter by 3.5 inches long).

Solution

The designer should assume that the nails will penetrate the subflooring and the floor framing members. The designer should also conservatively assume that the density of the subfloor sheathing and the floor framing is the same as the wall bottom plate (lowest density of the connected materials). These assumptions allow for the use of NDS table 12.3A. Alternatively, a more accurate nail design lateral capacity may be calculated using the yield equations of NDS•12.3.1.

Using NDS table 12.3A, the designer should note that the closest nail diameters in the table are 0.135 and 0.128 inches. Interpolating between these values, using a side member thickness of 1.5 inches, and assuming Spruce-Pine-Fir for all members, the following Z value is obtained—

$$Z = 79 + [(0.131-0.128)/(0.135-0.128)](88 \text{ lb} - 79 \text{ lb}) = 83 \text{ lb}^*$$

$$Z' = ZC_D = 83 \text{ lb} (1.6) = 133 \text{ lb}$$

*Using the NDS general dowel equations as presented in AF&PA Technical Report 12 (AF&PA, 1999), the calculated value is identical under the same simplifying assumptions. A higher design value of 90 pounds may be calculated, however, by using only the subfloor sheathing as a side member, with $G = 0.5$. The ultimate capacity is conservatively predicted as 261 pounds.

Assuming that both of the lateral loads act simultaneously at their full design value (a conservative assumption), the resultant design load is determined as follows.

$$\text{Resultant shear load} = \text{sqrt}[(250\text{plf})^2 + (120 \text{ plf})^2] = 277 \text{ plf}$$

Using the conservative assumptions above, the number of nails per linear foot of wall plate is determined as follows.

$$(277 \text{ lb})/(133 \text{ lb/nail}) = 2.1 \text{ nails per foot}$$

Rounding this number, the design recommendation is 2 nails per foot or 3 nails per 16 inches of wall plate.

Conclusion The number of 16d pneumatic nails (0.131 inch diameter) required is 2 nails per foot of wall bottom plate for the moderate loading condition evaluated. The number of nails may be reduced by using a larger diameter nail or by evaluating the nail lateral capacity using the yield equations of NDS•12.3.1.

As in example 7.3, some consideration of extensive experience in conventional residential construction should also be considered in view of the conventional fastening requirements of table 7.1 for wood sole plate to floor framing connections (that is, one 16d nail at 16 inches on center); refer to NDS•7.1.1.4. For the loads assumed in this example problem, two nails per 16 inches on center may be adequate. Testing has indicated that the ultimate capacity of two 16d pneumatic nails (0.131 inch diameter) can exceed 600 lb per nail for conditions similar to those assumed in this example problem; refer to section 7.3.6. The general dowel equations underpredict the ultimate capacity by approximately a factor of two. Using two 16d pneumatic nails at 16 inches on center may be expected to provide a safety factor of greater than 3 relative to the design lateral load assumed in this problem (that is, $[600 \text{ lb/nail}] \times [2\text{nails}/1.33 \text{ ft}]/277 \text{ plf} = 3.2$).

As noted in chapter 6, the ultimate capacity of base connections for shear walls should at least exceed the ultimate capacity of the shear wall for seismic design, and, for wind design, the connection should provide a safety factor of at least 2 relative to the wind load. For seismic design, the safety factor for shear walls recommended in this guide is 2.5; refer to chapter 6, section 6.5.2.3. Therefore, the fastening schedule of two 16d pneumatic nails at 16 inches on center is not quite adequate for seismic design loads of the magnitude assumed in this problem (that is, the connection does not provide a safety factor of at least 2.5). The reader is referred to chapter 3, section 3.8.4 for additional discussion on seismic design considerations and the concept of “balanced” design.

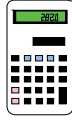

Given

- A 3x8 wood ledger board (Douglas-Fir) is used to support a side-bearing floor system.
- The ledger is attached to 3x4 wall studs (Douglas-Fir), spaced at 16 inches on center in a balloon-framed portion of a home; as a second condition, the ledger is attached to a concrete wall.
- The design shear load on the ledger is 300 plf because of floor live and dead loads.

Find

1. The spacing of 5/8-inch-diameter lag screws required to fasten the ledger to the wood wall framing.
2. The spacing of 5/8-inch-diameter anchor bolts required to fasten the ledger to a concrete wall.

Solution

1. Determine connection requirements for use of a 5/8-inch-diameter lag screw.

$$Z' = Z_C D C_g C_{\Delta} C_d \quad \text{(section 7.3.2)}$$

$$Z_{s\perp} = 630 \text{ lb}^* \quad \text{(NDS table 9.3A)}$$

$$C_D = 1.0 \quad \text{(normal duration load)}$$

$$C_g = 0.98 \text{ (2 bolts in a row)} \quad \text{(NDS table 7.3.6A)}$$

$$C_{\Delta} = 1.0^{**}$$

$$C_d = p/(8D) = (3.09 \text{ in})/[8(5/8 \text{ in})] = 0.62 \quad \text{(NDS 9.3.3)}$$

$$p = (\text{penetration into main member}) - (\text{tapered length of tip of lag screw})^{***}$$

$$= 3.5 \text{ in} - 13/32 \text{ in} = 3.09 \text{ in}$$

*The $Z_{s\perp}$ value is used for joints when the shear load is perpendicular to the grain of the side member (or ledger, in this case).

**A C_{Δ} value of 1.0 is predicated on meeting the minimum edge and end distances required for lag screws and bolts; refer to NDS 8.5.3 and NDS 9.4. The required edge distance in the side member is 4D from the top of the ledger (loaded edge) and 1.5D from the bottom of the ledger (unloaded edge), where D is the diameter of the bolt or lag screw. The edge distance of 1.5D is barely met for the nominal 3-inch-wide (2.5-inch-actual) stud, provided the lag screws are installed along the center line of the stud.

***A 6-inch-long lag screw will extend through the side member (2.5 inches thick) and penetrate into the main member 3.5 inches. The design penetration into the main member must be reduced by the length of the tapered tip on the lag screw (see appendix L of NDS for lag screw dimensions).

$$Z' = (630 \text{ lb})(1.0)(0.98)(1.0)(0.62) = 383 \text{ lb}$$

The lag bolt spacing is determined as follows.

$$\text{Spacing} = (383 \text{ lb/lag screw})/(300 \text{ plf}) = 1.3 \text{ ft}$$

Therefore, one lag screw per stud-ledger intersection may be used (that is, 1.33 ft spacing). The lag screws should be staggered about 2 inches from the top and bottom of the 3x8 ledger board. Because the bolts are staggered (that is, no two

bolts in a row), the value of C_g may be revised to 1.0 in the preceding calculations.

2. Determine connection requirements for use of a 5/8-inch-diameter anchor bolt in a concrete wall.

$$Z' = ZC_D C_g C_{\Delta} \quad (\text{section 7.3.2})$$

$$\begin{aligned} Z_{\perp} &= 650 \text{ lb}^* && (\text{NDS table 8.2E}) \\ C_D &= 1.0 && (\text{normal duration load}) \\ C_g &= 1.0^{**} \\ C_{\Delta} &= 1.0^{***} \end{aligned}$$

* The Z_{\perp} value is used because the ledger is loaded perpendicular to grain.

**The bolts will be spaced and staggered, not placed in a row.

***Edge and end distance requirements of NDS•8.5.3 and NDS•8.5.4 will be met for full design value.

$$Z' = (650 \text{ lb})(1.0)(1.0)(1.0) = 650 \text{ lb}$$

The required anchor bolt spacing is determined as follows.

$$\text{Spacing} = (650 \text{ lb}) / (300 \text{ plf}) = 2.2 \text{ ft}$$

Therefore, the anchor bolts should be spaced at approximately 2 ft on center and staggered from the top and bottom edge of the ledger by a distance of approximately 2 inches.

Note: In conditions in which this connection is also required to support the wall laterally (that is, an outward tension load because of seismic loading on a heavy concrete wall), the tension forces may dictate additional connectors to transfer the load into the floor diaphragm. In lower wind or seismic load conditions, the ledger connection to the wall and the floor sheathing connection to the ledger are usually sufficient to transfer the design tension loading, even though that situation may induce some cross-grain tension forces in the ledger. The cross-grain tension stress may be minimized by locating every other bolt as close to the top of the ledger as is practical or by using a larger plate washer on the bolts.

Conclusion The design of bolted side-bearing connections was presented in this design example for two wall construction conditions. Although not a common connection detail in residential framing, it is one that requires careful design consideration and installation because it must transfer the floor loads (that is, from people) through a shear connection rather than through a simple bearing. The example also addresses the issue of appropriate bolt location with respect to edge and end distances. Finally, the designer was alerted to special connection detailing considerations in high wind and seismic conditions.

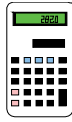

Given

- The foundation wall is connected to a wood sill plate and laterally supported, as shown in the following figure.
- Assume that the soil has a 30 pcf equivalent fluid density, and the unbalanced backfill height is 7.5 ft.
- The foundation wall unsupported height (from basement slab to top of wall) is 8 ft.
- The wood sill is preservative-treated Southern Yellow Pine.

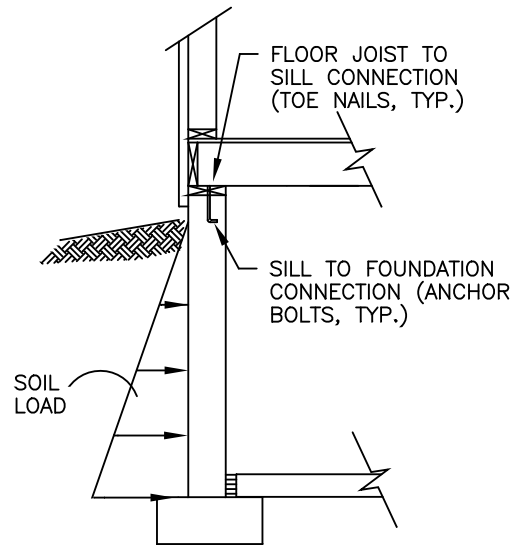

Find

1. The lateral load on the foundation wall to sill plate connection resulting from the backfill lateral pressure.
2. The required spacing of 1/2-inch-diameter anchor bolts in the sill plate.

Solution

1. Determine the lateral load on the sill plate connection.

Using the procedure in section 3.5 of chapter 3 and the associated beam equations in appendix A, the reaction at the top of the foundation wall is determined as follows.

$$R_{top} = ql^3/(6L) = (30 \text{ pcf})(7.5 \text{ ft})^3/[6(8 \text{ ft})] = 264 \text{ plf}$$

2. Determine the design lateral capacity of the anchor bolt and the required spacing.

$$Z' = Z_C D C_M C_t C_g C_\Delta \quad (\text{section 7.3.2})$$

Z_L	=	400 lbs*	(NDS table 8.2E)
C_D	=	0.9	(lifetime load duration, table 5.3)
C_M	=	1.0	(MC < 19%)
C_t	=	1.0	(temperature < 100°F)
C_g	=	1.0	(bolts not configured in rows)

*The value is based on a recommended 6-inch standard embedment of the anchor bolt into the concrete wall. Based on conventional construction experience, this value may also be applied to masonry foundation wall construction when bolts are properly grouted into the masonry wall (that is, by use of a bond beam).

$$Z' = (400 \text{ lb})(0.9) = 360 \text{ lb}$$

$$\text{Anchor bolt spacing} = (360 \text{ lb}) / (264 \text{ plf}) = 1.4 \text{ ft}$$

The check for conformance to ACI 318, appendix D, requires a check of shear on the bolt and concrete breakout strength caused by shear.

Bolt shear for hooked bolt anchors is determined by ACI 318 eq. D-20—
[below.]

V = $n0.6Af$, where:
 n = number of bolts (in this example, 1).
 A = effective cross-sectional area of bolt, including consideration for threads (in this example, assume A = cross-sectional area of $\frac{1}{2}$ " bolt = $\pi d^2/4 = 0.2 \text{ in}^2$).
 f = yield stress of anchor to be taken as the lesser of $1.9f_y$ or 125,000 psi. Because the bolt yield strength was not provided, assume 125,000 psi is the lesser.

$$\text{So } V = 1 * 0.6 * 0.2 \text{ in}^2 * 125,000 \text{ psi} = 15,000 \text{ lbs.} > 264 \text{ plf} * 4 \text{ ft (see note) OK}$$

Concrete breakout strength is determined by ACI 318, eq. D-21 for shear perpendicular to the edge of concrete. Assume the bolt is in the middle of the 8 in. wall.

V_c = $(A_{vc}/A_{vco}) * \psi_{ed} * \psi_c * \psi_h * V_{bolt}$, where:
 A_{vc}/A_{vco} = ratio of plan area of concrete breakout/volume of concrete breakout.
 ψ_{ed} = modification factor for edge effect, in this case = 1.0.
 ψ_c = modification factor for service loads and cracking, in this case = 1.4.
 ψ_h = modification factor for thin concrete members, in this case = 1.0.
 V_{bolt} = $264 \text{ plf} * 4 \text{ ft} = 1,056 \text{ lbs.}$

$$V_c = (24/72) * 1 * 1.4 * 1 * 1056 = 493 \text{ lbs.}$$

The allowable shear in the concrete wall is given by ACI 318.11.11 and is as follows.

V = $4\sqrt{f_c}d$, where:
 f_c = design compressive strength of concrete, assume for this example = 3,000 psi.
 d = depth of anchor bolt in concrete, in this example = 4 in.

$$V = 4 * 54.8 * 4 = 877 \text{ lb} > 493 \text{ lb OK}$$

Note: According to the above calculations, an anchor bolt spacing of about 16 inches on center is required in the sill plate. However, in conventional residential construction, extensive experience has shown that a typical anchor bolt spacing of 6 ft on center is adequate for typical conditions, as represented in this design example. This conflict between analysis and experience creates a dilemma for the designer that may be reconciled only by making judgmental use of the “extensive

experience” clause in NDS•7.1.1.4. Perhaps a reasonable compromise would be to require the use of a 5/8-inch-diameter anchor bolt at a 4 ft on center spacing. This design may be further justified by consideration of friction in the connection (that is, a 0.3 friction coefficient with a typical force resulting from dead load of the building). The large safety factor in wood connections may also be attributed to some of the discrepancy between practice or experience and analysis in accordance with the NDS. Finally, the load must be transferred into the floor framing through connection of the floor to the sill. In applications in which the loads are anticipated to be much greater (that is, a taller foundation wall with heavier soil loads), the joint may be reinforced with a metal bracket, as shown.

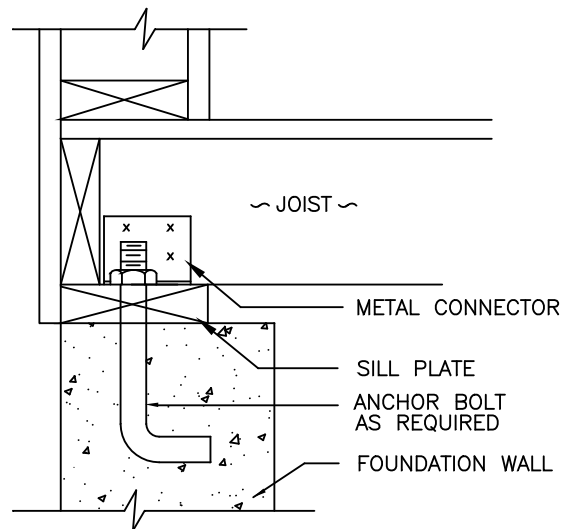

Conclusion This example demonstrates an analytic method of determining foundation lateral loads and the required connections to support the top of the foundation wall through a wood sill plate and floor construction. It also demonstrates the discrepancy between calculated connection requirements and conventional construction experience that may be negotiated by permissible designer judgment and use of conventional residential construction requirements.

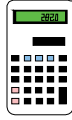

Given Maximum transverse shear load on bottom of wall is 1,050 plf (from soil).
 Dead load on wall is 1,704 plf.
 Yield strength of reinforcement is 60,000 psi.
 Wall thickness is 8 inches.
 Assume $\mu = 0.6$ for concrete placed against hardened concrete not intentionally roughened.
 $f_c = 3,000$ psi

Find Whether a dowel or key is required to provide increased shear transfer capacity. (If a dowel or key is required, size accordingly.)

Solution

1. Determine factored shear load on wall due to soil load (that is, 1.6H per chapter 3, table 3.1).

$$V = 1,050 \text{ plf}$$

$$V_u = 1.6 (1,050 \text{ plf}) = 1,680 \text{ plf}$$

2. Check friction resistance between the concrete footing and wall.

$$V_{\text{friction}} = \mu N = \mu(\text{dead load per foot of wall})$$

$$= (0.6)(1,704 \text{ plf}) = 1,022 \text{ plf} < V_u = 1,680 \text{ plf}$$

Therefore, a dowel or key is needed to secure the foundation wall to the footing.

3. Determine a required dowel size and spacing (section 7.2 and ACI-318•5.14).

$$A_{vf} = V_u / (\phi f_y \mu)$$

$$= (1,680 \text{ plf}) / [(0.85)(60,000)(0.6)] = 0.05 \text{ in}^2 \text{ per foot of wall}$$

Try a No. 4 bar ($A_v = 0.20 \text{ in}^2$) and determine the required dowel spacing as follows:

$$A_{vf} = A_v / S$$

$$0.05 \text{ in}^2 / \text{lf} = (0.2 \text{ in}^2) / S$$

$$S = 48 \text{ inches}$$

Conclusion This example problem demonstrates that, for the given conditions, a minimum of one No. 4 rebar at 48 inches on center is required to adequately restrict the wall from slipping. Alternatively, a key may be used or the basement slab may laterally support the base of the foundation wall.

It should be noted that the factored shear load due to the soil lateral pressure is compared to the estimated friction resistance in step 1 without factoring the friction resistance; no clear guideline exists in this matter of designer judgment.

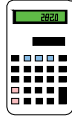
**Given**

- A 1/2-inch-diameter anchor bolt is 4 feet on center with a 6-inch embedment depth in an 8-inch thick concrete wall.
- The bolt is an ASTM A36 bolt with $f_y = 36$ ksi, and the following design properties for ASD; refer to AISC Manual of Steel Construction (AISC, 2011)—

$$F_t = 19,100 \text{ psi (allowable tensile stress)}$$

$$F_u = 58,000 \text{ psi (ultimate tensile stress)}$$

$$F_v = 10,000 \text{ psi (allowable shear stress)}$$

- The specified concrete has $f'_c = 3,000$ psi.
- The nominal design (unfactored) loading conditions are as follows.

$$\text{Shear load} = 116 \text{ plf}$$

$$\text{Uplift load} = 285 \text{ plf}$$

$$\text{Dead load} = 180 \text{ plf}$$

Find

Determine whether the bolt and concrete are adequate for the given conditions.

Solution

1. Check shear in bolt using appropriate ASD steel design specifications (AISC, 2011) and the ASD load combinations in chapter 3.

$$f_v = \frac{\text{shear load}}{\text{bolt area}} = \frac{116 \text{ plf (4 ft)}}{(0.196 \text{ in}^2)} = 2,367 \text{ psi}$$

$$F_v = 10,000 \text{ psi}$$

$$f_v \leq F_v \quad \text{OK}$$

2. Check tension in bolt resulting from uplift using appropriate ASD steel design specifications (AISC, 2011) and the appropriate ASD load combination in chapter 3.

$$T = [(285 \text{ plf}) - 0.6 (180 \text{ plf})] (4 \text{ ft}) = 708 \text{ lb}$$

$$f_t = \frac{T}{A_{\text{bolt}}} = \frac{708 \text{ lb}}{0.196 \text{ in}^2} = 3,612 \text{ psi}$$

$$f_t \leq F_t$$

$$3,612 \text{ psi} < 19,100 \text{ psf} \quad \text{OK}$$

3. Check tension in concrete (anchorage capacity of concrete) using ACI-318•11.3 (and ACI 318, appendix D) and the appropriate LRFD load combination in chapter 3. Note that the assumed cone shear failure surface area, A_v , is approximated as the minimum of π (bolt embedment length)² or π (wall thickness)².

$$V_u = T = [1.5 (285 \text{ plf}) - 0.9 (180 \text{ plf})] (4 \text{ ft}) = 1,062 \text{ lb}$$

$$A_v = \text{minimum of } \begin{cases} \pi (6 \text{ in})^2 = 113 \text{ in}^2 \\ \pi (8 \text{ in})^2 = 201 \text{ in}^2 \end{cases}$$

$$\phi V_c = \phi 4 A_v \sqrt{f'_c} = (0.85)(4)(113 \text{ in}^2) = 21,044 \text{ lb}$$

$$V_u \leq \phi V_c$$

$$1,062 \text{ lb} \leq 21,044 \text{ lb} \quad \text{OK}$$

Conclusion A 1/2-inch-diameter anchor bolt with a 6-inch concrete embedment and spaced 4 feet on center is adequate for the given loading conditions. In lieu of using an anchor bolt, the designer may choose to use one of the many strap anchors that are also available. The strap anchor manufacturer typically lists the embedment length and concrete compressive strength required corresponding to strap gauge and shear and tension ratings. In this instance, a design is not typically required; the designer simply ensures that the design loads do not exceed the strap anchor's rated capacity.

7.6 References

- American Concrete Institute (ACI). 2008. *Building Code Requirements for Masonry Structures*. ACI Standard 530. Farmington Hills, MI: American Concrete Institute.
- . 2011. *Building Code Requirements for Structural Concrete and Commentary*. ACI Standard 318-11. Farmington Hills, MI: American Concrete Institute.
- American Forest & Paper Association (AF&PA). 1999. *General Dowel Equations for Calculating Lateral Connection Values*. Technical Report 12. Washington, DC American Forest & Paper Association.
- American Institute of Steel Construction (AISC). 2011. *Manual of Steel Construction, 14th Ed.* Chicago, IL, American Institute of Steel Construction .
- American Society of Testing and Materials (ASTM). 2011. *Standard Specification for Driven Fasteners: Nails, Spikes, and Staples*, ASTM F1667. West Conshohocken, PA: American Society of Testing and Materials.
- . 2012. *Standard Terminology of Nails for Use With Wood and Wood-Base Materials*. ASTM F547. West Conshohocken, PA: American Society of Testing and Materials.
- American Wood Council (AWC). 2012. *National Design Specification for Wood Construction (NDS)*. Washington, DC: American Wood Council.
- . 2014. *General Dowel Equations for Calculating Lateral Connection Values*. Technical Report 12. Washington, DC: American Wood Council.
- Conner, H., D. Gromala, and D. Burgess. 1987. “Roof Connections in Houses: Key to Wind Resistance,” *Journal of Structural Engineering* 113 (12): 2459-2474.
- Cunningham, T.P. 1993. *Roof Sheathing Fastening Schedules for Wind Uplift*. APA Report T92-28. Tacoma, WA: American Plywood Association.
- Hoyle, R.J., and F.R. Woeste. 1989. *Wood Technology in the Design of Structures*, 5th ed. Ames, IA: Iowa State University Press.
- U.S. Department of Housing and Urban Development (HUD). 1999a. *Perforated Shear Walls With Conventional and Innovative Base Restraint Connections*. Prepared by the National Association of Home Builders

(NAHB) Research Center, Inc., for the U.S. Department of Housing and Urban Development. Washington, DC: Government Printing Office.

———. 1999b. *Reliability of Conventional Residential Construction: An Assessment of Roof Component Performance in Hurricane Andrew and Typical Wind Regions of the United States*. Prepared by the National Association of Home Builders (NAHB) Research Center, Inc., for the U.S. Department of Housing and Urban Development. Washington, DC: Government Printing Office.

International Code Council, Inc. (ICC). 2012. *International Residential Code*. Country Club Hills, IL: International Code Council, Inc.

International Code Council Evaluation Services (ICC-ES). 2013. *Power-Driven Staples and Nails*. Report No. ESR-1539. Whittier, CA: International Code Council Evaluation Services.

McLain, T.E. 1997. “Design Axial Withdrawal Strength From Wood: II. Plain-Shank Common Wire Nails,” *Forest Products Journal* 47 (6): 103.

Mizzell, D.P., and S.D. Schiff. 1994. *Wind Resistance of Sheathing for Residential Roofs*. Clemson, SC: Clemson University.

Murphy, S., S. Pye, and D. Rosowsky. 1995. *System Effects and Uplift Capacity of Roof Sheathing Fasteners*. New York: Structures Congress, American Society of Civil Engineers.

Reed, T.D., D.V. Rosowsky, and S.D. Schiff. 1996. *Uplift Capacity of Rafter-to-Wall Connections in Light-Frame Construction*. Clemson, SC: Clemson University.

Showalter, J., P. Line, and P. Douglas. 1999. *Calculation of Lateral Connection Values Using General Dowel Equations*. American Society of Agricultural Engineers, Paper No. 994176. St. Joseph, MI: ASAE.

Stieda, C.K.A. 1999. *Lateral Strength of Bolted Wood-to-Concrete Connections*, Vancouver, British Columbia, Canada: Forintek Canada Corp.

Appendix A

Shear and Moment

Diagrams and

Beam Equations

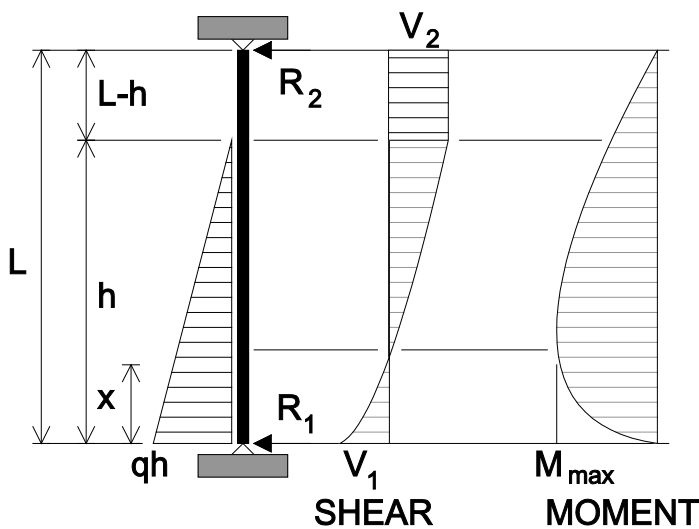

q = equivalent fluid density of soil (pcf)

qh = soil pressure (psf) at $x = 0$

$$V_2 = -R_2 = -\frac{qh^3}{6L}$$

$$V_1 = R_1 = \frac{1}{2}qh^2 \left(1 - \frac{h}{3L}\right)$$

$$V_x = V_1 - \frac{1}{2}xq(2h - x) \text{ (where } x < h\text{)}$$

$$V_x = V_2 \text{ (where } x \geq h\text{)}$$

$$M_x = V_1x - \frac{1}{2}qhx^2 + \frac{1}{6}qx^3 \text{ (where } x < h\text{)}$$

$$M_x = -V_2(L - x) \text{ (where } x \geq h\text{)}$$

$$x_{@M_{max}} = h - \sqrt{h^2 - \frac{2V_1}{q}}$$

$$\Delta_{max} \text{ (at } x \cong L/2) \cong \frac{qL^3}{EI} \left[\frac{hL}{128} - \frac{L^2}{960} - \frac{h^2}{48} + \frac{h^3}{144L} \right]$$

Figure A.1. Simple Beam (Foundation Wall)—Partial Triangular Load

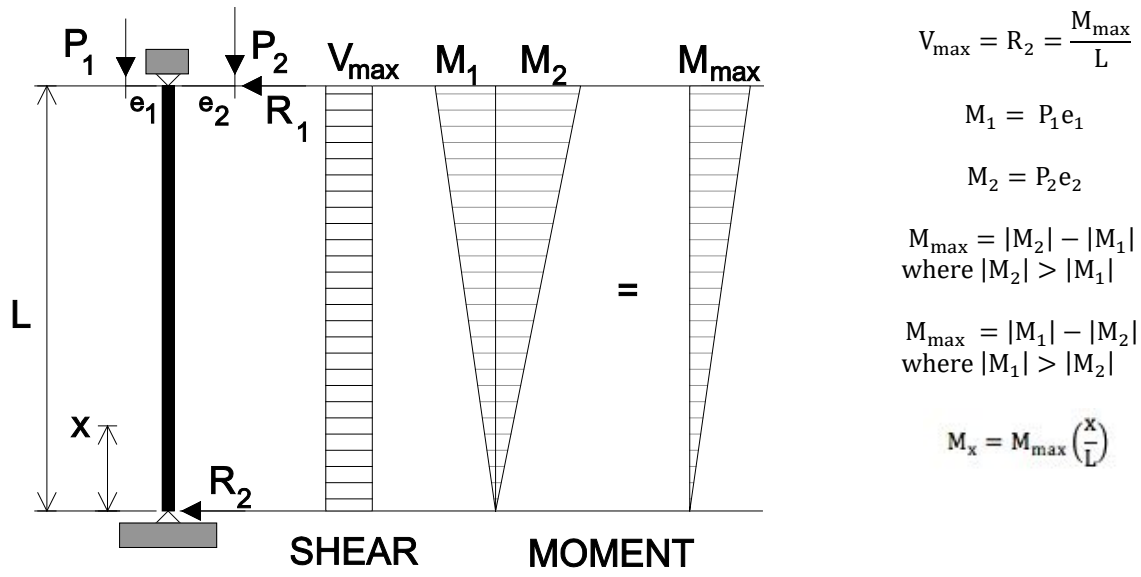

Figure A.2. Simple Beam (Wall or Column)—Eccentric Point Load

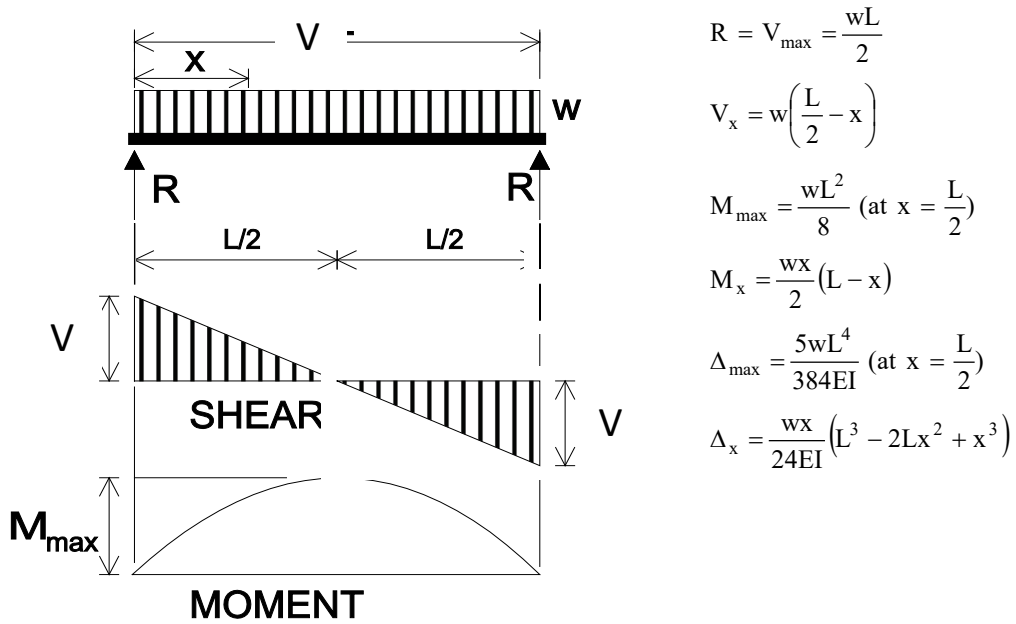
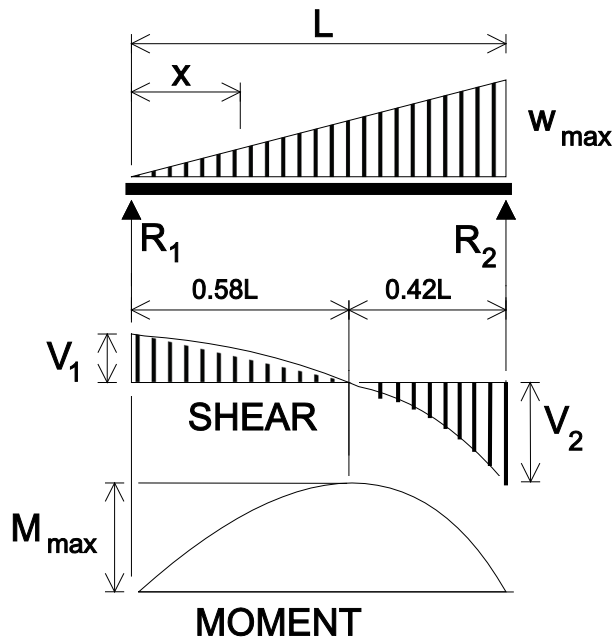

Figure A.3. Simple Beam—Uniformly Distributed Load



$$R_1 = V_1 = \frac{w_{\max}}{3}$$

$$R_2 = V_2 = \frac{2w_{\max}}{3}$$

$$V_x = \frac{w_{\max}}{3} - \frac{w_{\max}^2}{L^2}$$

$$M_{\max} \text{ (at } x = \frac{L}{\sqrt{3}}) = \frac{2w_{\max}L}{9\sqrt{3}}$$

$$M_x = \frac{w_{\max}x}{3L^2}(L^2 - x^2)$$

$$x_{\max} \text{ (at } x = L\sqrt{1 - \sqrt{\frac{8}{15}}}) = \frac{w_{\max}L^3}{77EI}$$

$$x = \frac{w_{\max}x}{180EIL^2}(3x^4 - 10L^2x^2 + 7L^4)$$

Figure A.4. Simple Beam—Load Increasing Uniformly to One End

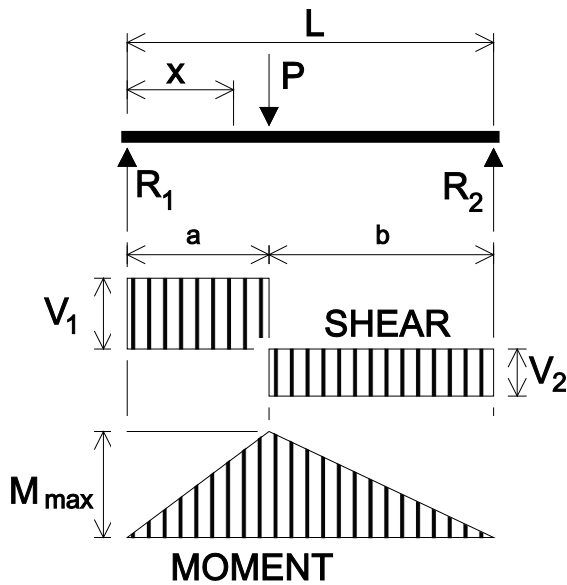

$$R_1 = V_1 \text{ (max when } a < b) = \frac{Pb}{L}$$

$$R_2 = V_2 \text{ (max when } a > b) = \frac{Pa}{L}$$

$$M_{\max} \text{ (at point of load)} = \frac{Pab}{L}$$

$$M_x \text{ (when } x < a) = \frac{Pbx}{L}$$

$$\Delta_{\max} \text{ [at } x = \sqrt{\frac{a(a+2b)}{3}} \text{ when } a < b] = \frac{Fab(a+2b)\sqrt{3a(a+2b)}}{27EIL}$$

$$\Delta_a \text{ (at point of load)} = \frac{Pa^2b^2}{3EIL}$$

$$\Delta_x \text{ (when } x < a) = \frac{Pbx}{6EIL}(L^2 - b^2 - x^2)$$

Figure A.5. Simple Beam—Concentrated Load at Any Point

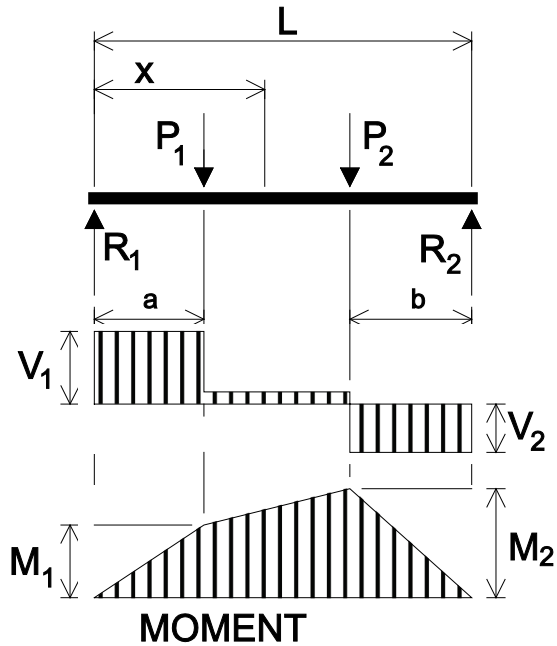

$$R_1 = V_1 = \frac{P_1(L - a) + P_2 b}{L}$$

$$R_2 = V_2 = \frac{P_1 a + P_2(L - b)}{L}$$

$$V_x \text{ [when } a < x < (L - b)] = R_1 - P_1$$

$$M_1 \text{ (max when } R_1 < P_1) = R_1 a$$

$$M_2 \text{ (max when } R_2 < P_2) = R_2 b$$

$$M_x \text{ (when } x < a) = R_1 x$$

$$M_x \text{ [when } a < x < (L - b)] = R_1 x - P_1(x - a)$$

Figure A.6. Simple Beam—Two Unequal Concentrated Loads Unsymmetrically Placed

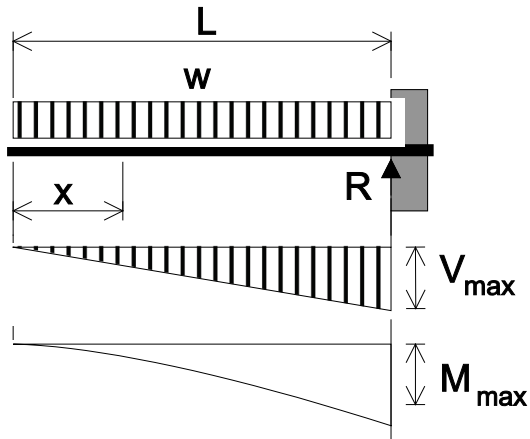

$$R = V_{\max} = wL$$

$$V_x = wx$$

$$M_{\max} \text{ (at fixed end)} = \frac{wL^2}{2}$$

$$M_x = \frac{wx^2}{2}$$

$$\Delta_{\max} \text{ (at free end)} = \frac{wL^4}{8EI}$$

$$\Delta_x = \frac{w}{24EI} (x^4 - 4L^3x + 3L^4)$$

Figure A.7. Cantilever Beam—Uniformly Distributed Load

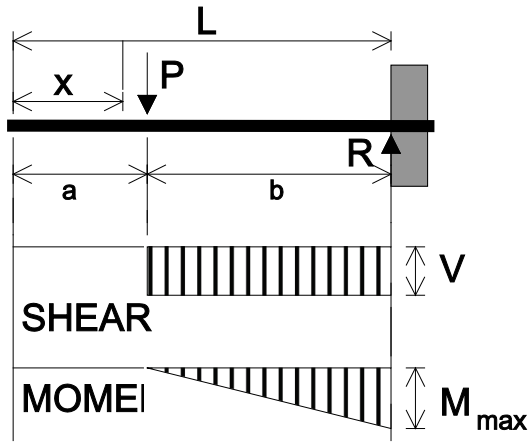

$$R = V = P$$

$$M_{\max} \text{ (at fixed end)} = Pb$$

$$M_x \text{ (when } x > a) = P(x-a)$$

$$\Delta_{\max} \text{ (at free end)} = \frac{Pb^2}{6EI} (3L - b)$$

$$\Delta_a \text{ (at point of load)} = \frac{Pb^3}{3EI}$$

$$\Delta_x \text{ (when } x < a) = \frac{Pb^2}{6EI} (3L - 3x - b)$$

$$\Delta_x \text{ (when } x > a) = \frac{P(L-x)^2}{6EI} (3b - L + x)$$

Figure A.8. Cantilever Beam—Concentrated Load at Any Point

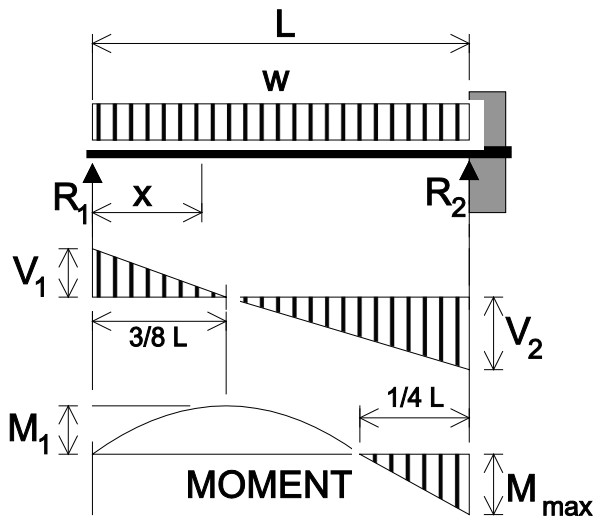

$$R_1 = V_1 = \frac{3wL}{8}$$

$$R_2 = V_2 = V_{\max} = \frac{5wL}{8}$$

$$V_x = R_1 - wx$$

$$M_{\max} = \frac{wL^2}{8}$$

$$M_1 \text{ (at } x = 0) = \frac{3}{8}L = \frac{9}{128}wL^2$$

$$M_x = R_1x - \frac{wx^2}{2}$$

$$\Delta_{\max} \text{ (at } x = \frac{L}{16}(1 + \sqrt{33}) = 0.42L) = \frac{wL^4}{185EI}$$

$$\Delta_x = \frac{wx}{48EI} (L^3 - 3Lx^2 + 2x^3)$$

Figure A.9. Beam Fixed at One End, Supported at Other—Uniformly Distributed Load

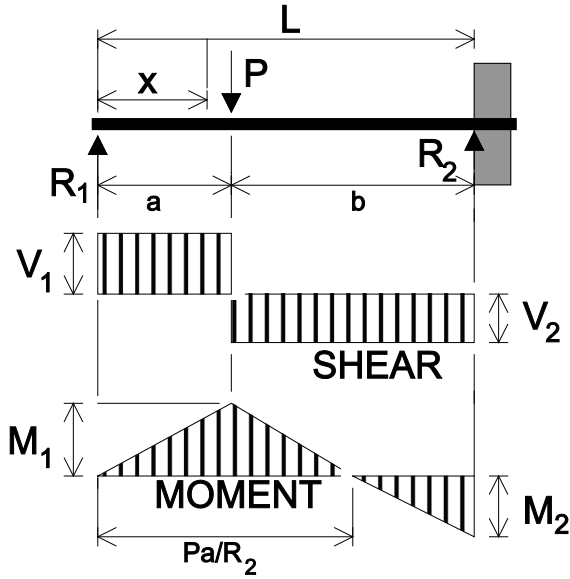

$$R_1 = V_1 = \frac{Pb^2}{2L^3} (a + 2L)$$

$$R_2 = V_2 = \frac{Pa}{2L^3} (3L^2 - a^2)$$

$$M_1 \text{ (at point of load)} = R_1 a$$

$$M_2 \text{ (at fixed end)} = \frac{Pab}{2L^2} \frac{Pab}{2L^2} (a + L)$$

$$M_x \text{ (when } x < a) = R_1 x$$

$$M_x \text{ (when } x > a) = R_1 x - P(x-a)$$

$$\Delta_{\max} \text{ (when } a < 0.4L \text{ at } x = L \frac{L^2 + a^2}{3L^2 - a^2}) = \frac{Pa}{3EI} \frac{(L^2 - a^2)^3}{(3L^2 - a^2)^2}$$

$$\Delta_{\max} \text{ (when } a > 0.4L \text{ at } x = L \sqrt{\frac{a}{2L+a}}) = \frac{Pab^2}{6EI} \sqrt{\frac{a}{2L+a}}$$

$$\Delta_a \text{ (at point of load)} = \frac{Pa^2 b^3}{12EIL^3} (3L + a)$$

$$\Delta_x \text{ (when } x < a) = \frac{Pa^2 x}{12EIL^3} (3aL^2 - 2Lx^2 - ax^2)$$

$$\Delta_x \text{ (when } x > a) = \frac{Pa}{12EIL^3} (L-x)^2 (3L^2 x - a^2 x - 2a^2 L)$$

Figure A.10. Beam Fixed at One End, Supported at Other—Concentrated Load at Any Point

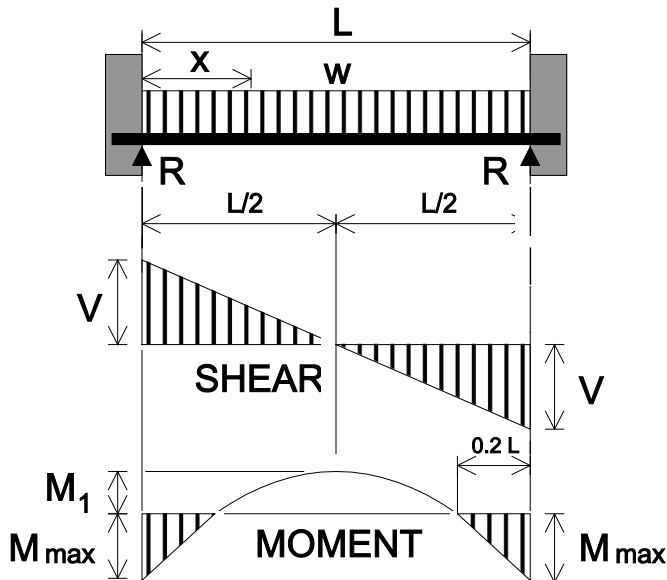

$$R = V = \frac{wL}{2}$$

$$V_x = w \left(\frac{L}{2} - x \right)$$

$$M_{\max} \text{ (at ends)} = \frac{wL^2}{12}$$

$$M_1 \text{ (at center)} = \frac{wL^2}{24}$$

$$M_x = \frac{w}{12} (6Lx - L^2 - 6x^2)$$

$$\Delta_{\max} \text{ (at center)} = \frac{wL^4}{384EI}$$

$$\Delta_x = \frac{wx^2}{24EI} (L-x)^2$$

Figure A.11. Beam Fixed at Both Ends—Uniformly Distributed Load

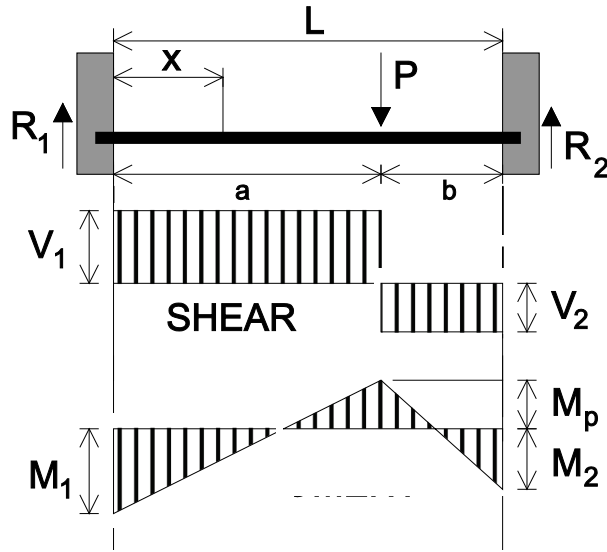

$$R_1 = V_1 \text{ (max. when } a < b) = \frac{Pb^2}{L^3} (3a + b)$$

$$R_2 = V_2 \text{ (max. when } a > b) = \frac{Pa^2}{L^3} (a + 3b)$$

$$M_1 \text{ (max. when } a < b) = \frac{Pab^2}{L^2}$$

$$M_2 \text{ (max. when } a > b) = \frac{Pa^2b}{L^2}$$

$$M_a \text{ (at point of load)} = \frac{2Pa^2b^2}{L^3}$$

$$M_x \text{ (when } x < a) = R_1x - \frac{Pbx^2}{L^2}$$

$$\Delta_{\max} \text{ (when } a > b \text{ at } x = \frac{2aL}{3a+b}) = \frac{2Pa^3b^2}{3EI(3a+b)^2}$$

$$\Delta_a \text{ (at point of load)} = \frac{Pa^3b^3}{3EIL^3}$$

$$\Delta_x \text{ (when } x < a) = \frac{Pb^2x^2}{6EIL^3} (3aL - 3ax - bx)$$

Figure A.12. Beam Fixed at Both Ends—Concentrated Load at Any Point

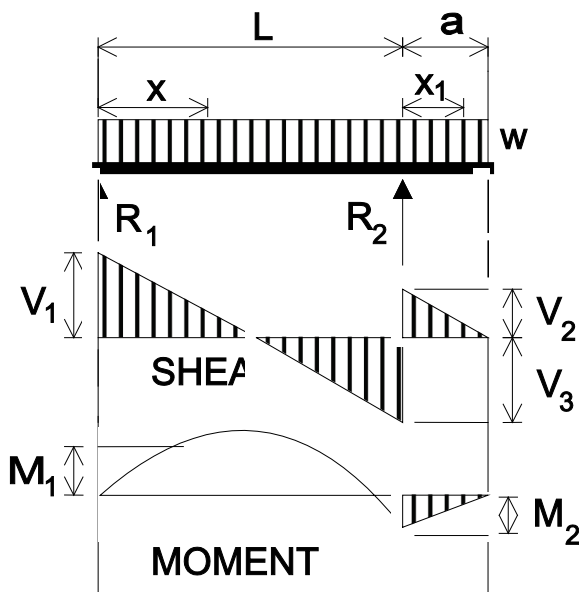

$$R_1 = V_1 = \frac{w}{2L} (L^2 - a^2)$$

$$R_2 = V_2 + V_3 = \frac{w}{2L} (L + a)^2$$

$$V_2 = wa$$

$$V_3 = \frac{w}{2L} (L^2 + a^2)$$

$$V_x \text{ (between supports)} = R_1 - wx$$

$$V_{x_1} \text{ (for overhang)} = w(a - x_1)$$

$$M_1 \text{ (at } x = \frac{L}{2} \left[1 - \frac{a^2}{L^2} \right]) = \frac{w}{8L^2} (L + a)^2 (L - a)^2$$

$$M_2 \text{ (at } R_2) = \frac{wa^2}{2}$$

$$M_x \text{ (between supports)} = \frac{wx}{2L} (L^2 - a^2 - xL)$$

$$M_{x_1} \text{ (for overhang)} = \frac{w}{2} (a - x_1)^2$$

$$\Delta_x \text{ (between supports)} = \frac{24EIL}{wx} (L^4 - 2L^2x^2 + Lx^3 -$$

$$2a^2L^2 + 2a^2x^2) - \frac{wx_1}{24EI} = (4a^2L - L^3 + 6a^2x_1 - 4ax_1^2 + x_1^3)$$

Figure A.13. Beam Overhanging One Support—Uniformly Distributed Load

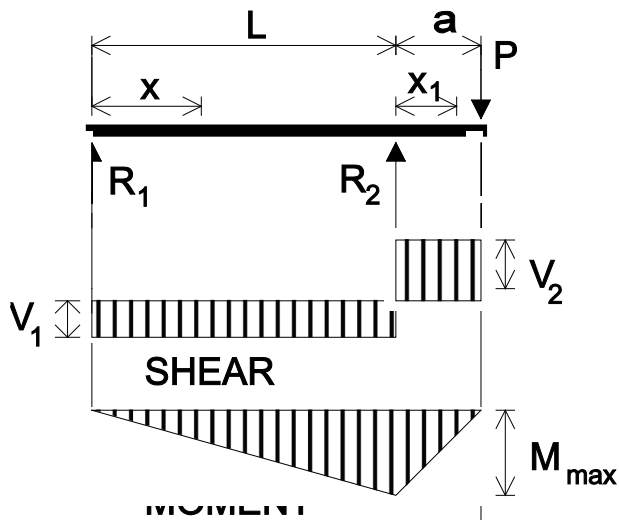

$$R_1 = V_1 = \frac{Pa}{L}$$

$$R_2 = V_1 + V_2 = \frac{P}{L}(L + a)$$

$$V_2 = P$$

$$M_{\max} (\text{at } R_2) = Pa$$

$$M_x (\text{between supports}) = \frac{Pax}{L}$$

$$M_{x_1} (\text{for overhang}) = P(a - x_1)$$

$$\Delta_{\max} (\text{between supports at } x = \frac{L}{\sqrt{3}}) = \frac{PaL^2}{9\sqrt{3}EI}$$

$$\Delta_{\max} (\text{for overhang at } x_1 = a) = \frac{Pa^2}{3EI}(L + a)$$

$$\Delta_x (\text{between supports}) = \frac{Pax}{6EI}(L^2 - x^3)$$

$$\Delta_x (\text{for overhang}) = \frac{Px_1}{6EI}(2aL + 3ax_1 - x_1^2)$$

Figure A.14. Beam Overhanging One Support—Concentrated Load at End of Overhang

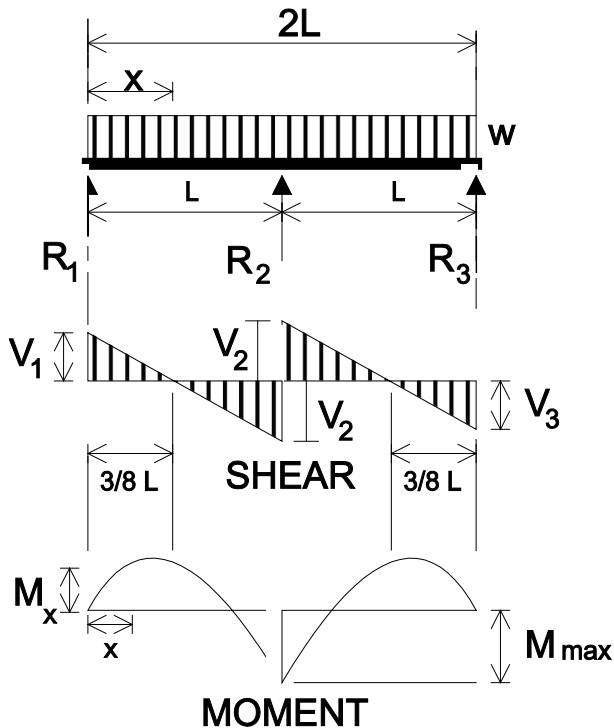

$$R_1 = V_1 = R_3 = V_3 = \frac{3wL}{8}$$

$$R_2 = \frac{10wL}{8}$$

$$V_2 = V_m = \frac{5wL}{8}$$

$$M_{\max} = -\frac{wL^2}{8}$$

$$M_1 \left[\text{at } x = \frac{3L}{8} \right] = \frac{9wL^2}{128}$$

$$M_x \left[\text{at } x < L \right] = \frac{3wLx}{8} - \frac{wx^2}{2}$$

$$\frac{3wLx}{8} - \frac{wx^2}{2}$$

$$\Delta_{\max} \left[\text{at } x \cong 0.46L \right] = \frac{wL^4}{185EI}$$

Figure A.15 Continuous Beam—Two Equal Spans and Uniformly Distributed Load

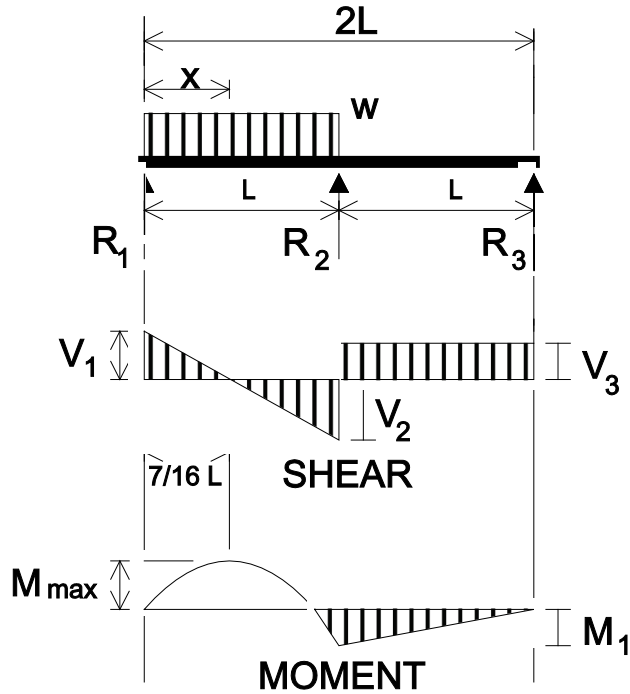

$$R_1 = V_1 = \frac{7}{16} wL$$

$$R_2 = V_2 + V_3 = \frac{5}{8} wL$$

$$R_3 = V_3 = -\frac{1}{16} wL$$

$$V_2 = \frac{9}{16} wL$$

$$M_{\max} [\text{at } x = \frac{7}{16} L] = \frac{49}{512} wL^2$$

$$M_1 [\text{at } R_2] = -\frac{1}{16} wL^2$$

$$M_x [\text{at } x < L] = \frac{wx}{16} - \frac{wx}{16} (7L - 8x)$$

$$\Delta_{\max} [\text{at } x \cong 0.47L] = \frac{wL^4}{109EI}$$

Figure A.16. Continuous Beam—Two Equal Spans With Uniform Load on One Span

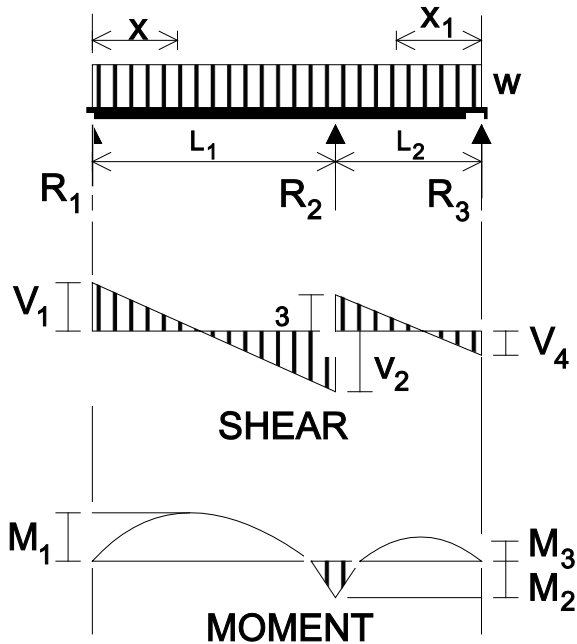

$$R_1 = V_1 = \frac{M_1}{L_1} + \frac{wL_1}{2}$$

$$R_2 = wL_1 + wL_2 - R_1 - R_3$$

$$R_3 = V_4 = \frac{M_1}{L_1} + \frac{wL_2}{2}$$

$$V_2 = wL_1 - R_1$$

$$V_3 = wL_2 - R_3$$

$$M_1 [\text{at } x < L_1, \text{ max. at } x = \frac{R_1}{w} - \frac{R_1}{w}] = R_1 x = \frac{wx^2}{2}$$

$$M_2 = -\frac{wL_2^3}{8(L_1 + L_2)} - \frac{wL_1^3}{8(L_1 + L_2)}$$

$$M_3 [\text{at } x_1 < L_2, \text{ max. at } x_1 = \frac{R_3}{w} - \frac{R_3}{w}] = R_3 x_1 - \frac{wx_1^2}{2}$$

Figure A.17. Continuous Beam—Two Unequal Spans and Uniformly Distributed Load

Appendix B

Unit Conversions

The following list provides the conversion relationship between U.S. customary units and the International System of Units (SI). A complete guide to SI and its use can be found in ASTM E380, *Standard for Metric Practice*.

To Convert From	to	Multiply by
Length		
inch (in)	centimeter (cm)	2.54
inch (in)	meter (m)	0.0254
foot (ft)	meter (m)	0.3048
yard (yd)	meter (m)	0.9144
mile (mi)	kilometer (km)	1.61
Area		
square foot (sq ft)	square meter (sq m)	0.0929030
square inch (sq in)	square centimeter (sq cm)	6.452
square inch (sq in)	square meter (sq m)	0.00064516
square yard (sq yd)	square meter (sq m)	0.839127
square mile (sq mi)	square kilometer (sq km)	2.6
Volume		
cubic inch (cu in)	cubic centimeter (cu cm)	16.38706
cubic inch (cu in)	cubic meter (cu m)	0.00001639
cubic foot (cu ft)	cubic meter (cu m)	0.0283168
cubic yard (cu yd)	cubic meter (cu m)	0.7645549
gallon (gal) U.S. liquid	liter (l)	3.78541
gallon (gal) U.S. liquid	cubic meter (cu m)	0.00378541
Force		
kip (1,000 lb)	kilogram (kg)	453.6
kip (1,000 lb)	Newton (N)	4,448.22
pound (lb)	kilogram (kg)	0.453592
pound (lb)	Newton (N)	4.44822
Stress or pressure		
kip/square inch (ksi)	megapascal (Mpa)	6.89476
kip/square inch (ksi)	kilogram/square centimeter (kg/sq cm)	70.31
pound/square inch (psi)	kilogram/square centimeter (kg/sq cm)	0.07031
pound/square inch (psi)	pascal (Pa) ^b	6,894.757
pound/square inch (psi)	megapascal (Mpa)	0.00689476
pound/square foot (psf)	kilogram/square meter (kg/sq m)	4.8824
pound/square foot (psf)	pascal (Pa)	47.88

Mass (weight)		
pound (lb) avoirdupois	kilogram (kg)	0.453592
ton (2,000 lb)	kilogram (kg)	907.185
Mass (weight) per length		
kip/linear foot (klf)	kilogram per meter (kg/m)	1.488
pound/linear foot (plf)	kilogram per meter (kg/m)	1.488
Moment		
foot-pound (ft-lb)	Newton-meter (N-m)	1.356
Mass per volume (density)		
pound per cubic foot (pcf)	kilogram per cubic meter (kg/cu m)	16.0185
pound per cubic yard (lb/cu yd)	kilogram per cubic meter (kg/cu m)	0.5933
Velocity		
mile per hour (mph)	kilometer per hour (km/hr)	1.60934
mile per hour (mph)	kilometer per second (km/sec)	0.44704
Temperature		
degree Fahrenheit (°F)	degree Celsius (°C)	$t_C = (t_F - 32) / 1.8$

^aA pascal equals 1,000 Newton per square meter.

The following prefixes and symbols are commonly used to form names and symbols of the decimal multiples and submultiples of the SI units.

Multiplication Factor		Prefix	Symbol
1,000,000,000	=	10 ⁹	giga G
1,000,000	=	10 ⁶	mega M
1,000	=	10 ³	kilo k
0.01	=	10 ⁻²	centi c
0.001	=	10 ⁻³	milli m
0.000001	=	10 ⁻⁶	micro μ
0.000000001	=	10 ⁻⁹	nano n

U.S. Department of Housing and Urban Development
Office of Policy Development and Research
Washington, DC 20410-6000



October 2017