

No. 633,072.

Patented Sept. 12, 1899.

A. W. & L. W. CASE.
PULP BOARD MAKING MACHINE.

(Application filed Oct. 13, 1898.)

(No Model.)

3 Sheets—Sheet 1.

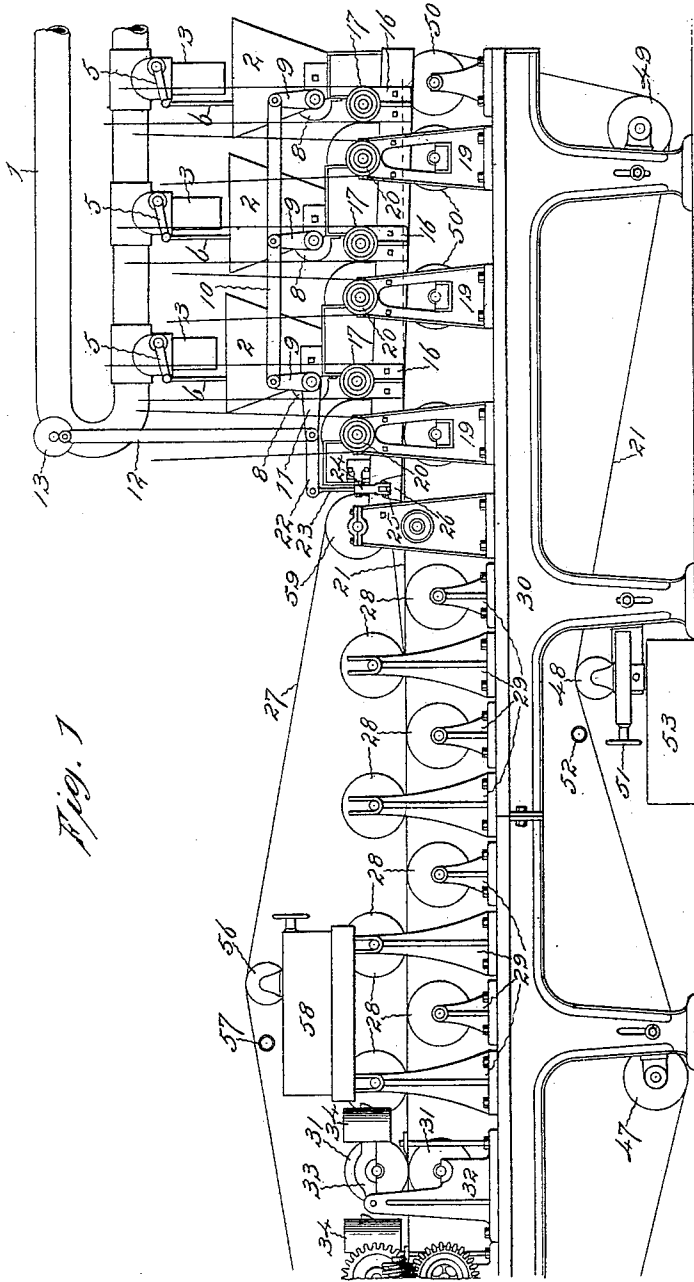

Fig. 1

Witnesses:

E. J. Hyde.

C. E. Buckland.

Inventors:

Alfred Wills Case

Lawrence W. Case

by
Harry R. Williams,
attys.

No. 633,072.

Patented Sept. 12, 1899.

A. W. & L. W. CASE.
PULP BOARD MAKING MACHINE.

(Application filed Oct. 13, 1898.)

(No Model.)

3 Sheets—Sheet 2.

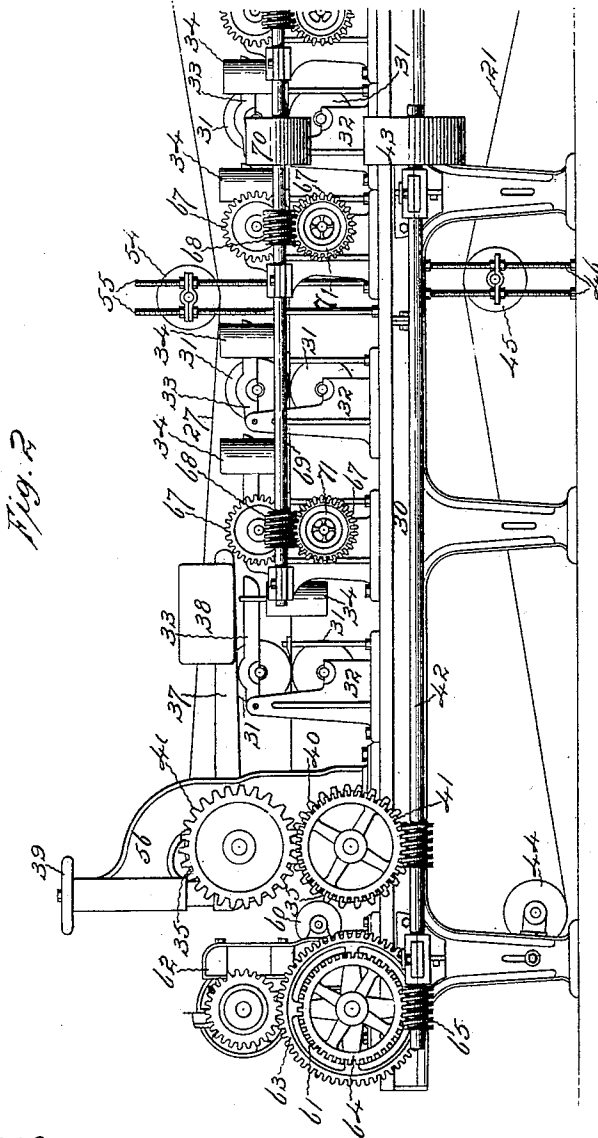

Fig. 2

Witnesses:

E. J. Hyde.

C. E. Buckland.

Inventors:

Alfred Wells Case &
Lawrence W. Case by
Harry P. Williams
att

No. 633,072.

Patented Sept. 12, 1899.

A. W. & L. W. CASE.
PULP BOARD MAKING MACHINE.

(Application filed Oct. 13, 1898.)

(No Model.)

3 Sheets—Sheet 3.

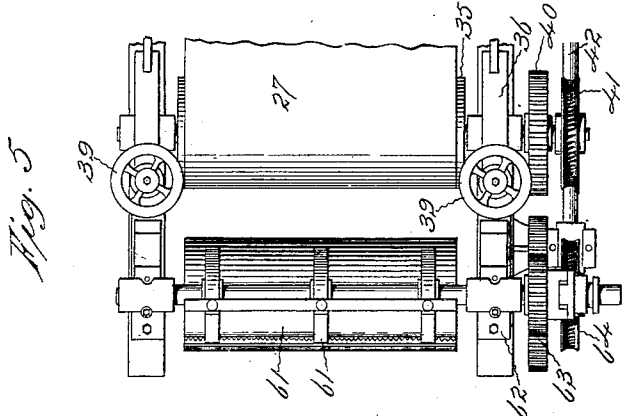

Fig. 5

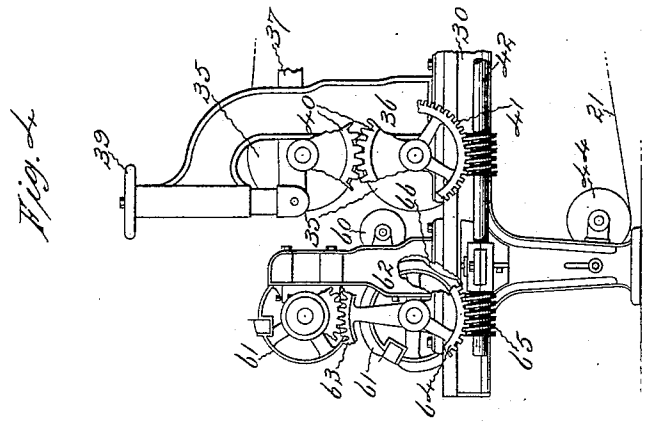

Fig. 4

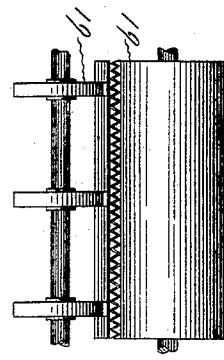

Fig. 6

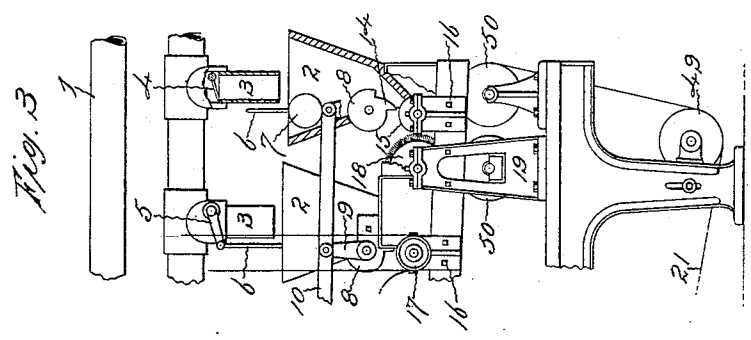

Fig. 3

Witnesses:

E. J. Hyde.

C. E. Buckland.

Inventors:

Alfred Wells Case &
Lawrence W. Case

Harry R. Williams,
att'y.

UNITED STATES PATENT OFFICE.

ALFRED WELLS CASE AND LAWRENCE W. CASE, OF HIGHLAND PARK,
CONNECTICUT.

PULP-BOARD-MAKING MACHINE.

SPECIFICATION forming part of Letters Patent No. 633,072, dated September 12, 1899.

Application filed October 13, 1898. Serial No. 693,366. (No model.)

To all whom it may concern:

Be it known that we, ALFRED WELLS CASE and LAWRENCE W. CASE, citizens of the United States, residing at Highland Park, in the county of Hartford and State of Connecticut, have invented certain new and useful Improvements in Pulp-Board-Making Machines, of which the following is a specification.

This invention relates to a machine for making board from fibrous materials which is particularly adapted for working leather-pulp, but which can be employed for making thick or thin board from pulp containing other fibrous stock.

The object of the invention is the production of a machine in which clean or greasy stock of any length of fiber can be worked equally well in an inexpensive manner into different thicknesses of board which will have a firm, uniform, and homogeneous texture, with the fibers so laid that it cannot be split or soaked and separated into layers, and which will have a surface capable of very smooth finish.

In the machine which is illustrated in the accompanying drawings as embodying the invention the pulp containing leather or other fibrous material, pumped directly from the beating-engine, if desired, is allowed by automatically-operating means to flow into hoppers, from which it is passed by feeders to slow-running feed-rolls. Rapidly-rotating distributing-cylinders catch the pulp from the feed-rolls and throw it upon an endless wire-cloth or felt apron. The pulp upon the wire-cloth, after having its edges properly cared for, is carried beneath another endless wire-cloth or felt apron, and between these it is subjected to the gradually-increasing squeeze of pressure-cylinders until it is sufficiently compacted, and then the continuous web into which it is formed is cut into sheets of sizes that are convenient for handling. The wire-cloths during their return travel pass stretching and guiding rolls and washing-jets which clean them of material which has become embedded in their meshes.

Figure 1 of the accompanying drawings shows a side elevation of a portion of a machine which embodies the invention. Fig. 2 shows a side elevation of the other portion of

the machine. Fig. 3 shows a side elevation, with parts cut in section, of the hopper end of the machine. Fig. 4 shows a side elevation, with parts in section, of the cutter end of the machine. Fig. 5 shows a plan of the cutter end of the machine, and Fig. 6 shows a side view of the cutter-cylinders.

Pulp containing leather or other fibrous material in a comparatively thick condition is circulated, usually by a pump, through the pipe 1, that, above the hoppers 2, of which there may be any desired number, has spouts 3. The feed-pipe preferably is turned back over itself, so that when there is a flow of pulp through it there will always be some pressure in the lower section at the spouts. In each of the spouts is a valve 4, and connected with the spindle of each valve is an arm 5, that is joined by a rod 6 with a float 7 in the hopper beneath. When the level of the pulp in a hopper is lowered, the dropping of the float in that hopper opens the valve in the spout above and permits the pulp to flow from the feed-pipe to replenish the supply in the hopper. In this manner all of the hoppers are kept supplied with pulp.

Mounted upon a shaft near the bottom of each hopper is a feeder 8. A rocker-arm 9 is connected with the end of each of these feeder-shafts, and these rocker-arms are joined by a bar 10. The shaft of one of the feeders is also provided with a rocker-arm 11, and this arm is connected by a link 12 with a crank-disk 13, that is adapted to be rotated by any suitable means. Through the medium of this crank and the rocker-arms these feeders are rapidly oscillated, so that the feeding-ribs 14 force the desired quantities of pulp through the bottoms of the hoppers upon the surfaces of the feeding-rolls 15. A feeding-roll is located at the opening through the bottom of each of the hoppers. The journals of the feeding-rolls are held in bearings in brackets 16, mounted upon a portion of the frame of the machine, and upon each journal is a pulley 17, adapted to be belted to any suitable source of driving power. These rolls are designed to run slowly.

In front of and in juxtaposition to each of the feed-rolls is a distributing-cylinder 18. The shafts of these cylinders are held by bearings in brackets 19 and are provided

with pulleys 20, which are belted so as to rotate the distributing-cylinders rapidly. The peripheral surfaces of these cylinders may be covered with carding-cloth, picker-teeth, brush-bristles, or similar materials, which will pick the pulp from the feed-rolls and then by centrifugal action throw it, with the fibers, in a promiscuous mass upon the surface of the endless apron 21, which preferably is wire-cloth, but which may be felt or any other fabric having sufficiently-open mesh.

The feeder in each hopper advances the pulp rapidly to the feed-rolls, which carry it in suitable quantities to the distributing-cylinders, and these cylinders deposit it in an even layer upon the apron. The cylinders are so near to each other that the fibers are matted together when deposited and form a web with a texture that is homogeneous and not stratified, although of course each succeeding cylinder deposits pulp upon that deposited by the preceding cylinder. The rapidity of movement of the feeders determines the amount of pulp fed, and their rate of speed, together with the number of hoppers in use, determines the amount of material deposited upon the apron. The number of hoppers in use may be varied according to the amount of stock it is desired in the finished sheets, but with a fixed number of hoppers the thickness of the sheets is regulated by the speed of the feeders.

An arm 22 is connected with the crank-disk 13, so as to be rocked when the machine is in operation. By means of a link 23 this arm is connected with an angle-lever 24, that is attached to a rod 25 that extends transversely of the machine and is movably supported by brackets mounted on the side frames. On this rod, near each side of the machine, is an edging-brush 26, formed of rubber or other suitable material. These edgers are, through the connection with the crank, moved transversely of the machine over the top of the wire-cloth 21, so as to crowd the edges of the pulp as it comes along and insure a straight edge of uniform thickness. The soft pulp has a tendency to thin out along the edges, and if it were not for these edgers the edges of the web would be thinner than the other portions and thus produce sheets of varying thickness, which is undesirable.

After the pulp has been edged it is carried by the traveling wire-cloth 21 beneath an upper endless wire-cloth 27, which converges toward and runs close to the top of the lower wire-cloth. As the wire-cloths run together gradually water is expressed without spreading or crushing out the soft pulp. The wire-cloths with the pulp between travel together for some distance between the upper and lower squeeze-rolls 28, that are supported by bearings in brackets 29, mounted upon the side frames 30 of the machine, so that they alternate with each other. These rolls squeeze

the wire-cloths together and cause them to express water from the pulp without breaking up the texture of the mass of fibers, as would be liable to occur if the soft pulp were first subjected to press-rolls arranged one above the other.

After the pulp has become so solidified by the expression of water that it will not be forced back when pressed, the web is passed between press-rolls 31, arranged in pairs one above the other. The lower of these press-rolls are held in bearings in brackets 32, mounted upon the side frames of the machine, and the upper of these rolls are held in bearings in levers 33, that are pivoted to the brackets and that are provided with adjustable weights 34. These weights on the levers are arranged so that the upper rolls press down upon and subject the pulp to a gradually-increasing pressure as it advances for continuing the solidification of the pulp. The pressing of the pulp is concluded by passing the wire-cloths between the feed-cylinders 35. The shaft of the lower of these cylinders is held in bearings attached to standards 36, mounted on the side frames, while the upper cylinder is held down by levers 37, pivoted to the standards and provided with heavy weights 38. The pivotal supports of these levers that hold the upper roll are adjustable by hand-wheels 39, attached to threaded spindles that turn in the upper ends of the standards. The shafts of these rolls are provided with intermeshing gear-wheels 40, and the lower shaft is also provided with a worm-wheel 41, in which meshes a worm on a shaft 42, that extends longitudinally of the machine and has a driving-pulley 43. By these mechanisms the cylinders 35 are rotated and caused to draw between them the wire-cloths and intermediate pulp. After passing these cylinders the lower wire-cloth runs around an idler-roll 44 and then over a stretching-roll 45, the shaft of which is held in bearings mounted upon vertical screw-threaded spindles 46. From the stretching-roll the wire-cloth passes beneath the idler-roll 47 over a guiding-roll 48 and after passing around an idler roll 49 travels back to the rolls 50, that support the wire-cloth beneath the hoppers. The guide-roll 48 is arranged with a common screw adjustment 51, whereby it may be moved, so as to cause the cloth to run straight upon the cylinders and rolls.

Located near the guiding-roll is a perforated pipe 52, that is connected with a water-supply. By means of this jets of water may be sprayed upon the lower wire-cloth for washing out matter that has become embedded in its meshes. Beneath the sprayer is a tray 53 for catching the water that is used for washing the cloth.

The upper wire-cloth after passing the cylinders 35 passes under a tightening-roll 54, that is supported in a common manner upon vertical threaded spindles 55, and then over

a guiding-roll 56. Near this guiding-roll is placed a perforated pipe 57, that is connected with a water-supply, whereby the upper wire-cloth may be washed and the pulp loosened from the meshes of the cloth. A tray 58 is located beneath this sprayer to catch the water that is emitted. From the guiding-roll the upper cloth travels around an idler-roll 59 and then to the first of the squeeze-rolls 28.

10 The compacted web of pulp is carried from the feed-cylinders 35 over a supporting-roll 60 to cutter-cylinders 61. Each of these cylinders has a saw-toothed cutting-blade, although blades of other forms may be employed, if desired. The shafts of the cutter-cylinders are supported in bearings fastened to standards 62, mounted on the side frames of the machine. The shafts of these cylinders are provided with intermeshing gears 63, 20 the upper preferably being one-half the size of the lower, so that the upper cylinder will rotate twice as fast as the lower. The lower shaft also has a worm-wheel 64, meshing with which is a worm 65 on the main driving-shaft 42. The cutting-teeth of the knives are arranged so that the points of one will pass between the points of the other. As the upper cylinder rotates twice as fast as the lower, when the teeth of the lower knife come around 30 and are thrust into the web the teeth of the upper knife come down and pass between those of the lower knife, thus severing the web. This severing is accomplished by a cut in the direction of the length of the web and in the direction in which it is moving, for the points of the upper knife are passing twice as fast as the points of the lower knife and as the web is being fed. Thus the blades act together to make a longitudinal separation as well as a transverse shear. With this form of blades the wet web of fibrous material, which is usually difficult to cut, is severed very satisfactorily. As the upper cutter-cylinder travels for this purpose twice as fast as 45 the lower, the lower is provided with a recess 66 into which the web sinks, so that the first time the upper knife comes around its points will not reach the web.

To assist the feed-cylinders in moving the wire-cloths, the shafts of several of the press-rolls 31 are provided with intermeshing gears 67, and the lower of these shafts have worm-wheels 71, meshing with which are worms 68 on a shaft 69, that has a driving-pulley 70.

55 The feeders pass the stock, which is supplied to the hoppers in suitable quantities, to the feeding-rolls, that deliver it evenly to the distributing-cylinders, which throw it upon the wire-cloth in a desirable state. With this manner of feeding, stock that is greasy and has long fibers may be utilized in a comparatively thick condition, and as but little water is required the texture of the mass of intermingled fibers is not destroyed by the expression of water and there is but little waste, for no amount of stock passes away with the water that is expressed.

Many different thicknesses of board may be formed on this machine, for the fibers may be thrown together in sufficient quantities by the distributing-cylinders to form a web of considerable thickness, and with thick board there is no ply that can be split or soaked so as to be torn apart. For these reasons leather fiber may be successfully worked in this machine and made into board that is successfully employed in shoe factories.

The wet web is gradually compacted, first by the converging wire-cloths, then by the alternately-arranged rolls, and afterward by the superposed rolls, and finally by the pressure of the feeding-cylinders. In this manner the web is compacted without tearing asunder the mass or disarranging the intermingled fibers.

Although the stock is placed upon the wire-cloth so as to be without ply, one side may be of one color and the other side another color by differently coloring the stock in the hoppers, for the stock from the first hopper will lie upon one side and the stock from the last hopper will lie upon the other side of the finished sheet. After the sheets have been cut from the web they are dried and pressed, or calendered, or otherwise finished in the usual manner.

We claim as our invention—

1. In combination in a board-forming machine, a hopper, a feeder located in the hopper, a rotating centrifugally-acting distributing-cylinder adjacent to the feeder, means for rotating the distributing-cylinder, a traveling apron passing adjacent to the distributing-cylinder, means for moving the apron, and squeeze-rolls for compacting the material deposited upon the apron, substantially as specified.

2. In combination in a board-forming machine, a plural number of hoppers, a feeder located in each hopper, a rotating centrifugally-acting distributing-cylinder adjacent to each feeder, means for rotating the distributing-cylinders, a traveling apron passing adjacent to the distributing-cylinders, means for moving the apron, and squeeze-rolls for compacting the material distributed upon the apron, substantially as specified.

3. In combination in a board-forming machine, a hopper, an oscillating feeder located in the hopper, means for oscillating the feeder, a rotating centrifugally-acting distributing-cylinder adjacent to the feeder, means for rotating the distributing-cylinder, a traveling apron passing adjacent to the distributing-cylinder, means for moving the apron, and squeeze-rolls for compacting the material distributed upon the apron, substantially as specified.

4. In combination in a board-forming machine, a hopper, a feeding-roll located adjacent to an opening in the hopper, means for rotating the feeding-roll, a rotating centrifugally-acting distributing-cylinder adjacent to the feeding-roll, means for rotating the dis-

tributing-cylinder, a traveling apron passing adjacent to the distributing-cylinder, means for moving the apron, and squeeze-rolls for compacting the material distributed upon the apron, substantially as specified.

5. In combination in a board-forming machine, a hopper, an oscillating feeder located in the hopper, means for oscillating the feeder, a feeding-roll located adjacent to an opening in the hopper, means for rotating the feeding-roll, a rotating centrifugally-acting distributing-cylinder adjacent to the feeding-roll, means for rotating the distributing-cylinder, a traveling apron passing adjacent to the distributing-cylinder, means for moving the apron, and squeeze-rolls for compacting the material distributed upon the apron, substantially as specified.

6. In combination in a board-forming machine, a supply-pipe, hoppers located below outlets in the supply-pipe, valves in the supply-pipe outlets, floats in the hoppers, connections between the valves and the floats, a centrifugally-acting distributing-cylinder adjacent to an opening in each hopper, means for rotating the distributing-cylinder, a traveling apron passing adjacent to the distributing-cylinder, means for moving the apron, and squeeze-rolls for compacting the material distributed upon the apron, substantially as specified.

7. In combination in a board-forming machine, a hopper, a rotating centrifugally-acting distributing-cylinder adjacent to an opening in the hopper, means for rotating the distributing-cylinder, traveling aprons converging toward each other and running together first above and then beneath a squeeze-roll, means for moving the aprons, and squeeze-rolls arranged alternately above and below the aprons, substantially as specified.

8. In combination in a board-forming machine, a hopper, a rotating centrifugally-acting distributing-cylinder adjacent to an opening in the hopper, means for rotating the distributing-cylinder, traveling aprons running together first above and then beneath a squeeze-roll, means for moving the aprons, squeeze-rolls arranged alternately above and below the aprons, and press-rolls arranged one above the other, substantially as specified.

9. In combination in a board-forming machine, a hopper, a rotating centrifugally-acting distributing-cylinder adjacent to an opening in the hopper, means for rotating the distributing-cylinder, traveling aprons running together between squeeze-rolls, means for moving the aprons, edgers located above the upper surface of the lower apron for keeping the edges of the pulp of uniform thickness, means for moving the edgers, and squeeze-rolls for expressing the water from the pulp, substantially as specified.

10. In combination in a board-forming machine, a hopper, a rotating centrifugally-acting distributing-cylinder adjacent to an opening in the hopper, means for rotating the dis-

tributing-cylinder, traveling aprons running together between squeeze-rolls, squeeze-rolls located alternately above and below the aprons, press-rolls arranged one above the other, feed-cylinders arranged one above the other, means for rotating the feed-cylinders, and means for rotating the press-rolls, substantially as specified.

11. In combination in a board-forming machine, a hopper, a rotating centrifugally-acting distributing-cylinder adjacent to an opening in the hopper, means for rotating the distributing-cylinder, squeeze-rolls, traveling aprons running together between squeeze-rolls, means for moving the aprons, cutter-cylinders, and means for rotating the cutter-cylinders, substantially as specified.

12. In combination in a board-forming machine, a hopper, a rotating centrifugally-acting distributing-cylinder adjacent to an opening in the hopper, means for rotating the distributing-cylinder, squeeze-rolls, traveling aprons running together between squeeze-rolls, means for moving the aprons, a cylinder bearing a toothed knife, a cylinder bearing a complementary toothed knife, and means for rotating one cylinder faster than the other, substantially as specified.

13. In combination in a board-forming machine, a hopper, a feeder located in the hopper, means for operating the feeder, a feeding-roll located adjacent to an opening in the hopper, means for rotating the feeding-roll, a rotating centrifugally-acting distributing-cylinder, means for rotating the distributing-cylinder, a traveling apron passing adjacent to the distributing-cylinder, edgers movable transversely of the apron, means for moving the edgers, alternately-arranged squeeze-rolls, superposed press-rolls, feed-cylinders, means for rotating the feed-cylinders, cutter-cylinders, and means for rotating the cutter-cylinders, substantially as specified.

14. In combination in a board-forming machine, a hopper, a feeder located in the hopper, means for operating the feeder, a feeding-roll located adjacent to an opening in the hopper, means for rotating the feeding-roll, a rotating centrifugally-acting distributing-cylinder, means for rotating the distributing-cylinder, a traveling apron passing adjacent to the distributing-cylinder, edgers movable transversely of the apron, means for moving the edgers, an apron passing along with the apron carrying the pulp, alternately-arranged squeeze-rolls, superposed press-rolls, feed-cylinders, means for rotating the feed-cylinders, cutter-cylinders, means for rotating the cutter-cylinders, tightening-rolls for stretching the aprons, guiding-rolls for straightening the aprons, and sprayers for washing the aprons, substantially as specified.

ALFRED WELLS CASE.
LAWRENCE W. CASE.

Witnesses:

E. C. STANLEY,
R. N. STANLEY.