

Chapter V

SEPTIC TANKS

INTRODUCTION	3
TANK MATERIALS AND SHAPES	4
COMPARTMENTED TANKS	6
SEPTIC TANK EFFLUENT FILTERS	8
SEPTIC TANK LOCATION	9
OPERATION OF SEPTIC SYSTEMS	10
WATER USE	10
THE EFFECTS OF WATER SOFTENER USE ON A WASTEWATER TREATMENT AND ABSORPTION SYSTEM	11
SEPTIC TANK MANAGEMENT AND MAINTENANCE	12
SEPTIC TANK START-UP	14
SEPTIC TANK MAINTENANCE	14
TANK INSPECTION	14
SEPTIC TANK PUMPERS	15
SEPTAGE DISPOSAL	16
SEPTIC TANK ABANDONMENT	16
SEPTIC TANK SAFETY	16
SEPTIC TANK DESIGN STANDARDS	17
GENERAL REQUIREMENTS	17
SPECIAL CONSIDERATIONS FOR CONCRETE TANKS	19
SPECIAL CONSIDERATIONS FOR FIBERGLASS AND PLASTIC TANKS	20
SEPTIC TANK PLACEMENT SPECIFICATIONS	20
REFERENCES AND ADDITIONAL READING	22

TABLES

V-1. MINIMUM SEPTIC TANK CAPACITIES BASED ON THE NUMBER OF HOUSEHOLD BEDROOMS.	3
V-2. INERT OR SLOW TO DECOMPOSE ITEMS THAT SHOULD NOT GO INTO A SEPTIC TANK	12
V-3. COMMON HOUSEHOLD HAZARDOUS WASTE	13

FIGURES

V-1. A TWO COMPARTMENT SEPTIC TANK	4
V-2. EXAMPLE OF POLYETHYLENE PLASTIC TANK	6
V-3. TWO SEPTIC TANKS IN SERIES	7
V-4. SEPTIC TANK EFFLUENT FILTERS	8
V-5. MEASURING SLUDGE AND SCUM IN A SEPTIC TAN	15

INTRODUCTION

The solids in raw household wastewater will quickly clog all but the most porous gravel formations. To enhance soil absorption, raw wastewater is discharged to a septic tank where solids are retained. A septic tank is a watertight chamber that:

- separates the settleable and floatable solids,
- promotes the growth of anaerobic bacteria necessary to decompose the solids, and
- provides storage for the resulting sludge and scum.

The septic tank reduces the velocity of wastewater and permits the settling of materials heavier than the liquid. Concurrently, scum, grease and other materials lighter than the water float to the top. A vertical section of a properly operating tank would show it divided into three distinct layers; scum at the top, a middle zone of generally clear water relatively free of solids called the “clear space”, and a bottom layer of sludge.

Septic tanks are designed to handle all the normal daily flow a household or business produces and should have sufficient capacity for a minimum detention of at least 2-3 times the daily wastewater flow. For this reason, design should be based upon the maximum capacity of a home rather than its number of inhabitants at any particular time. Minimum capacities for septic tanks are shown in Table V-1. The design should allow for the inclusion of laundry and garbage grinder wastes.

It is desirable to install larger tanks whenever possible. Tanks larger than the minimum have the advantage of more solids separation into the scum and sludge layers, and more solids storage. The larger capacity provides less carryover of solids, resulting in prolonged life of the soil absorption unit. Larger tanks also require less frequent cleaning and allow for future expansion of the home, which provides a positive cost-benefit return. Design flow capacity does not allow for roof drainage, other surface water, footing drainage, sump pump, or any other subsurface drainage, so these must be excluded from the system.

Table V-1. Minimum Septic Tank Capacities Based on the Number of Household Bedrooms.

Number of Bedrooms ¹	Septic Tank Capacity (gallons) ²	
	Minimum	Recommended
3	1,000 ³	1,350
4	1,200	1,800
5	1,500	2,250

¹For each additional bedroom add 150 gallons to the recommended value.

²Volume held by the tank below the liquid level (invert of the outlet pipe).

³Minimum tank size is 1,000 gal

Septic tanks are constructed with baffles or sanitary tees on both the inlet and outlet pipes. Baffles or tees retain floating scum and minimize the disturbance of the settled sludge or floating scum as wastewater enters and leaves the tank. Septic tank design should include provisions for

two openings through the top that are large enough for clean out and repair. These should be located to permit easy access to the tank inlet and outlet devices. It is important that the openings themselves are accessible and have covers that exclude water. Section views showing details for a concrete septic tank are in Figure V-1.

TANK MATERIALS AND SHAPES

Three types of materials have proven to be acceptable for long-term use of a tank: concrete, polyethylene plastic, and fiberglass. Although tanks have been made from metal, the corrosive atmosphere and contents cause rapid disintegration. The metal is soon compromised, leaving nothing but a rust-lined underground void, subject to collapse and obviously leaking. Simply stated, metal tanks should never be allowed in a wastewater treatment system.

Figure V-1. A Two Compartment Septic Tank

a. Top View, b. Side Section View

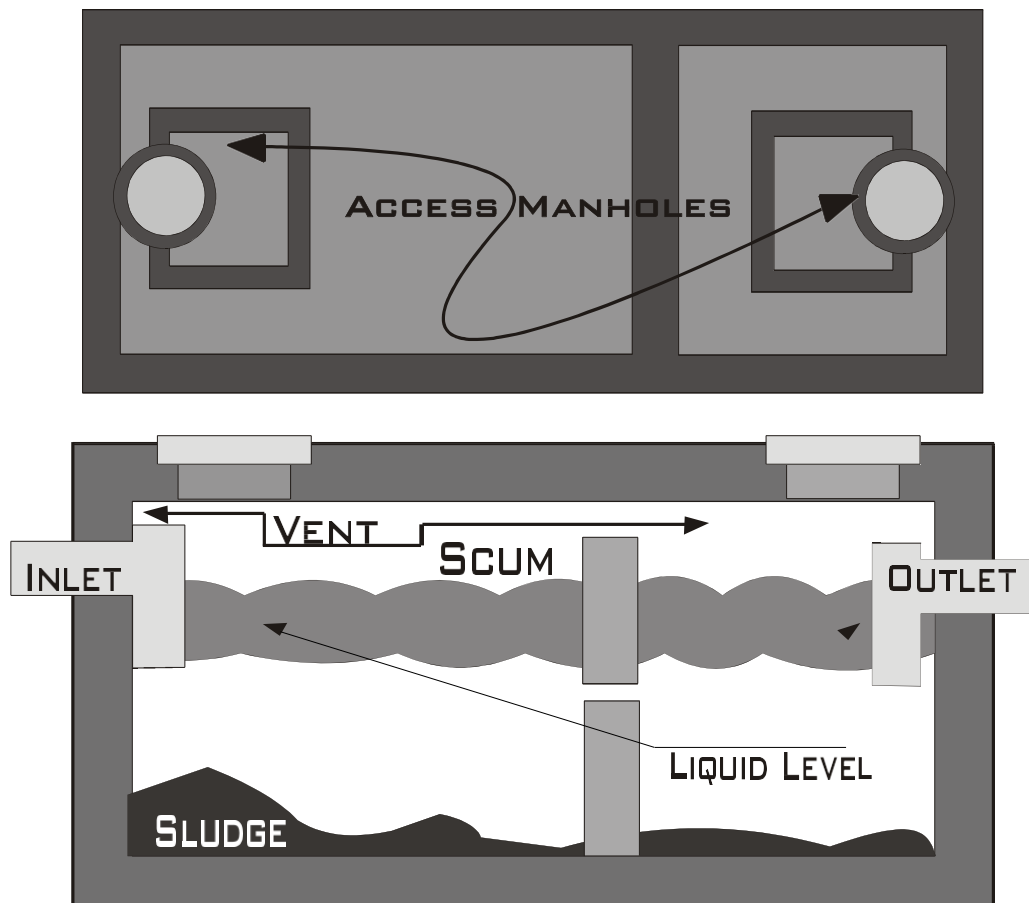

Box-like concrete septic tanks are the most common. Properly reinforced and mixed, concrete forms a pre-cast tank that is strong, durable, stable, and modest in cost. The metal reinforcement used in the sidewalls must be positioned in the form so that the metal is always covered by at

least an inch of concrete. If the rebar or wire mesh is exposed, not only is the concrete strength compromised, but the metal deterioration (as discussed previously) further weakens the tank. Any exposed reinforcement is a valid reason to reject that the tank.

Concrete septic tanks are very heavy, requiring special trucks for transport and placement. If struck or dropped, the concrete may crack. A cracked tank will leak and must be rejected. The tank forms should be filled with a single pour. If the form is partially filled and the concrete hardens before the rest of the fill, a “cold joint” is created. Cold joints are prone to seeping or leaking and are not acceptable in septic tanks. It is a good idea to fill a tank with water and check for leaks before placement in the ground.

A two-piece septic tank with a horizontal joint around the middle (also called a clam shell tank) is designed as two boxes that fit together, rim to rim. One box forms the bottom half and the other box (with the inlet and outlet in opposite ends and the hatch or hatches in the top) is the top half. The bottom half is placed in the excavation, a rubber or asphalt sealer is fitted completely around the rim before the top half is lowered into place on the sealer. This design divides the weight between the two halves, making it easier to handle and position. However, the potential for leakage is great along the seam where the two halves meet. This tank can only be checked for leakage **after** it has been placed. Should leaks be detected, it is necessary to pump out the water and reseal before testing again. Leakage has been a real disadvantage of the two-piece design, and its use has fallen out of favor.

Fiberglass and polyethylene plastic tanks are so similar that both are discussed here as “plastic tanks”. Plastic tanks are manufactured by molding and are usually round or capsule-shaped (horizontal cylinder). Because the entire tank is formed as a single piece, there are no seams to seal, and the material is resistant to impact damage. These tanks’ great advantage as well as their disadvantage, is their light weight. The lightness allows these tanks to be transported in an ordinary pick-up. The tank can be set in place with only a backhoe or hand-carried by a few people. These tanks are life-savers in situations where a heavy truck cannot gain access to place a concrete tank. Figure V-2 shows an example of a polyethylene plastic septic tank.

Due to their lightness, plastic tanks **must** be installed according to the manufacturer’s instructions. This usually involves setting the tank on a carefully leveled and compacted sand or small gravel bed in the bottom of the excavation. Sand or fill is tamped around the tank as it is filled with water. Failure to observe the procedures stipulated by the manufacture can result in a tilted or deformed tank, or one that literally floats out of the ground. Plastic tanks are deeply ribbed for reinforcement and for a better “grip” by the soil. Although plastic tanks are readily available for many uses, only those specifically designed for use as septic tanks can be used for this purpose.

Figure V-2. Example of Polyethylene Plastic Tank

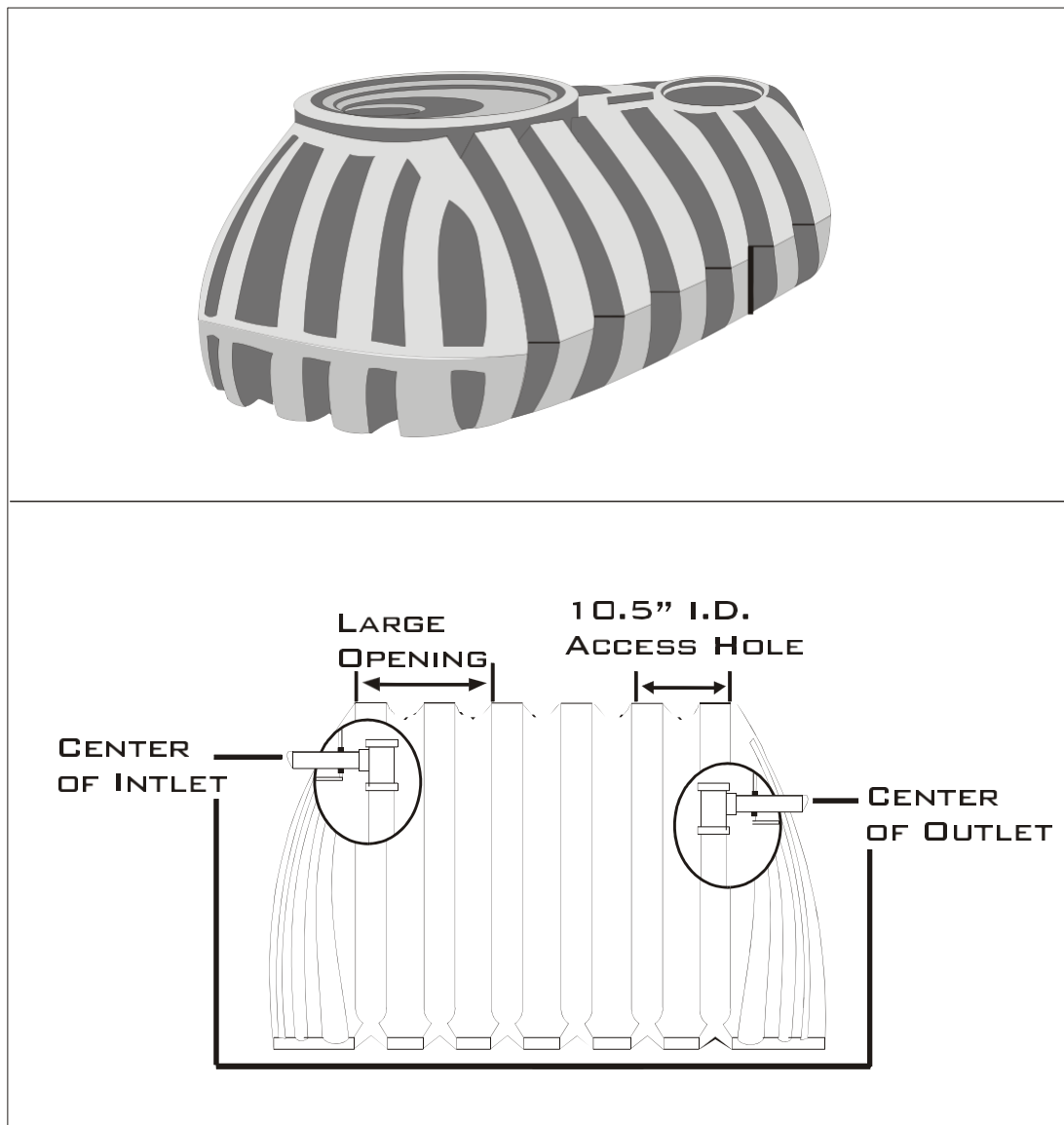

COMPARTMENTED TANKS

Although a single compartment tank can give acceptable performance, research data indicates that multiple compartment tanks perform better because they provide greater protection against solids carryover into the discharge pipe. Multiple compartment tanks have been recommended because of improved effluent quality. Adding a high quality effluent filter to a single compartment tank may provide equal or higher quality effluent than a 2 compartment tank with no effluent filter.

The term “compartmented” as used here, refers to chambers within a tank or tanks placed in series. A number of arrangements are possible. Figure V-1 illustrates a single tank with a

watertight partition separating the individual compartments. The first compartment should have a volume of one half to two thirds of the total tank capacity. The total tank capacity must meet the minimum capacities shown in Table V-1 and should be 2-3 times the expected daily flow. Separate units can be linked together, one flowing into another as in Figure V-3.

Figure V-3. Two Septic Tanks In Series

(plan view, not to scale)

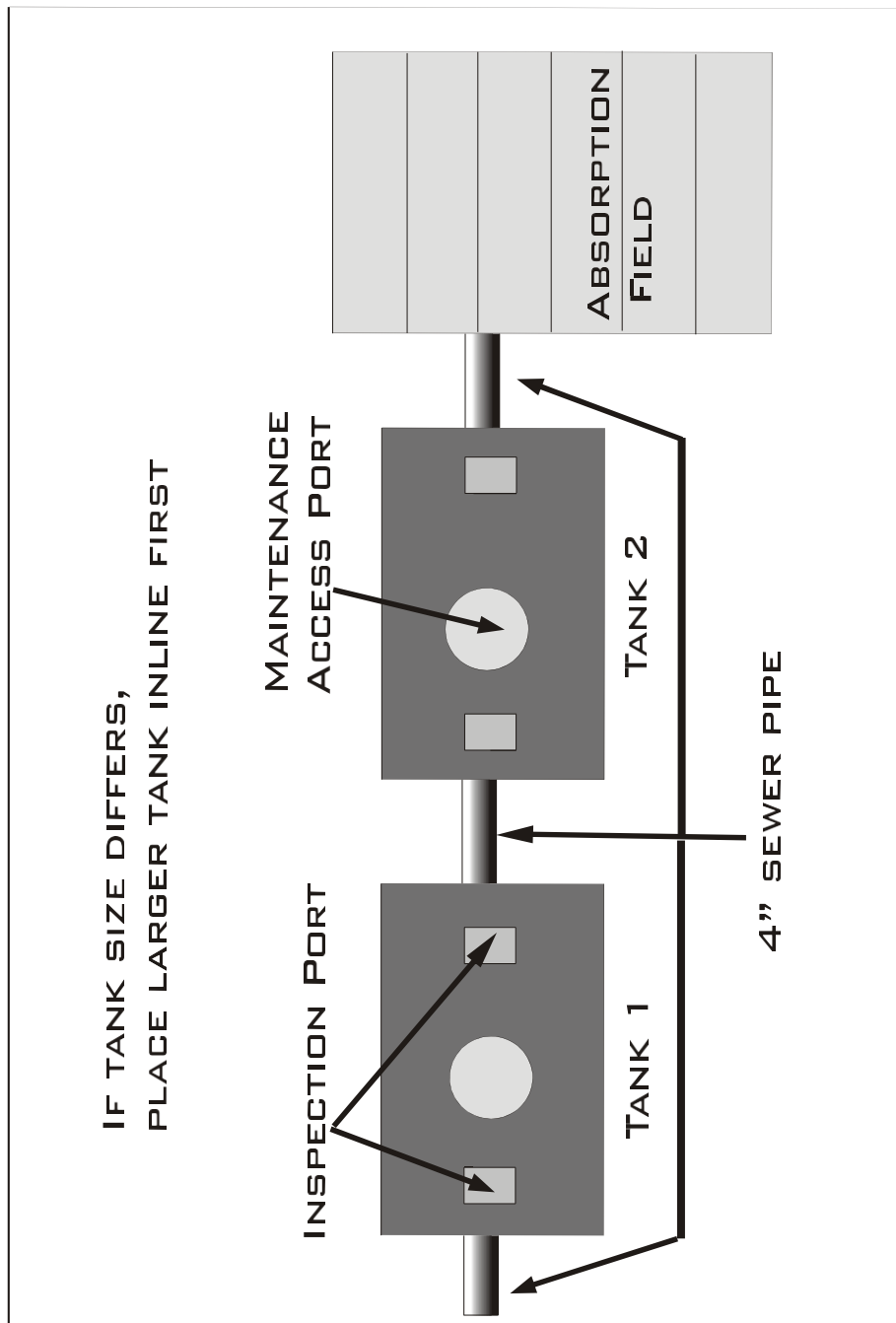

SEPTIC TANK EFFLUENT FILTERS

Septic tank effluent filters, see figure V-4, are usually placed inside a septic tank at the outlet. Effluent filters are effective in reducing the amount of suspended solids and BOD in effluent from the septic tank. These internal filters provide an added measure of protection for the soil absorption field. Effluent filters can reduce the effects of water that surges through the septic tank and also reduce or prevent damage to treatment components that follow the septic tank. Septic tank effluent filters may increase the life of soil absorption systems and their use is highly recommended.

Effluent filters should be cleaned according to the manufacturer's directions. They may be cleaned by the system owner or by a qualified maintenance technician on a periodic schedule. If the filter is not periodically cleaned, it will eventually clog, causing the effluent to back-up into the house and/or overflow the top of the tank. Effluent filters can provide an important safeguard against solids entering the drainfield but they require maintenance. Should the occupants notice water draining slowly, the filter should be checked immediately.

The cleaning process involves removing the effluent filter from the septic tank and spraying the filter clean with a garden hose. To prevent the spread of infectious agents and other pollutants from the tank, all the debris from the filter should be washed back into the tank for removal when the tank is pumped.

Figure V-4. Septic Tank Effluent Filters

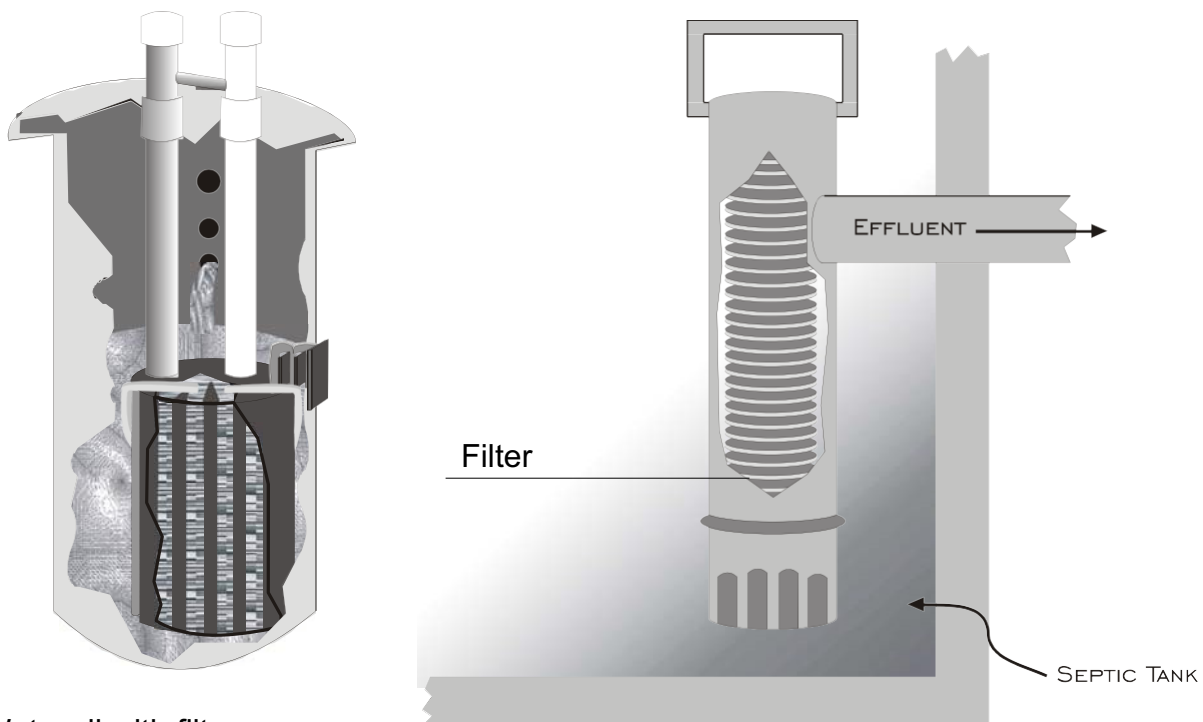

Wet well with filter –
can be added into effluent
line from septic tank

SEPTIC TANK LOCATION

The location chosen for a septic tank must consider:

- potential pollution of groundwater and surface water
- protection of a foundation's structural integrity
- protection of the septic tank from damage
- access for maintenance (pumping)
- possible future construction

Septic tanks should be located where they will not cause contamination of any well, spring, or other source of water supply. Underground pollution usually moves in the same direction of the normal groundwater movement in the locality, (i.e. from the area of higher water table to the area of lower water table). In general, the water table follows the contours of the ground surface. However, rock layers, their slope, fractures, and joints may cause dramatic differences in this general rule.

Surface elevations can be deceiving. Pollution from an onsite wastewater system at a lower surface elevation may travel downward into the same water-bearing stratum that supplies a well located uphill. Horizontal and vertical separation distances are critical for the protection of groundwater from septic system effluent. Tanks should never be closer than 50 feet to any source of water and greater distances are preferred, if possible. A 100-foot separation is required if the water source serves a public drinking water system.

Contrary to popular belief, septic tanks do not provide a high degree of bacteria removal. Although the sewage undergoes some treatment as it passes through the tank, this does not mean that infectious agents will be removed. Septic tank effluent is not safe for discharge onto the ground surface or into ditches or watercourses. The liquid discharged from a tank is in some respects, more objectionable than that which goes into a tank; it is septic and malodorous. This, however, does not detract from the value of the tank. As previously explained, the primary purpose of the septic tank is to remove solids and scum from the sewage to prevent clogging of the soil in the absorption field. Further treatment of the effluent, including removal of disease-producing organisms, is accomplished by water movement through the soil. Bacteria are removed as the sewage is filtered by the soil, and bacteria die out quickly in the unfavorable environment of the soil.

The septic tank should not be located closer than 10 feet from any building or within the 100-year flood plain. The tank should not be sited in swampy areas, or in areas subject to flooding. In general, the tank should be located to allow the largest possible area available for the soil absorption system. There must be no permanent cover (patio, building, driveway, etc.) over the tank, lateral, or any other part of an onsite wastewater system. Consideration should also include easy access of trucks and equipment for pumping, maintenance, and repair. To avoid damage to the system, heavy equipment should not have to cross any portion of the wastewater system when servicing the septic tank. In addition, the tank should not be located in an area of any future construction

Minimum separation distances from property lines, foundations, and other objects must be maintained. Required and recommended separation distances are addressed in the previous chapter, Chapter IV, *Site and Soil Evaluations*; see Table IV-7 and Figure IV-3.

Septic tank covers should always be easily accessible. Access ports at the surface are most desirable and must be within 12 inches of final surface grade. If it is not possible to have the tank this shallow, an extension collar or riser should be provided over each opening so the lid is no deeper than 12 inches from the surface. When a riser is necessary, the riser must be installed carefully and must be water tight. All joints and covers on the septic tank must be waterproof to prevent the introduction of surface water or groundwater into the tank.

A sketch of the onsite wastewater system, as constructed, should be made by the inspector and/or contractor and delivered to the regulating agency. This information should be kept on file with the agency and a copy provided to the homeowner. Each access manhole for the septic tank and other system components should be shown on the sketch with reference points and distances to at least two permanent surface objects at cross angles to each other. This process will permit locating the tank for future inspection and maintenance while minimizing disturbances to the landscape.

Both onsite systems serving new facilities and existing onsite wastewater systems at times need to be inspected. Inspection protocols and example forms for new onsite systems and for evaluating existing systems are included in Chapter VII, *Soil Absorption Systems*.

OPERATION OF SEPTIC SYSTEMS

Operation and maintenance of a septic tank system is important. A system that is neglected or misused will have a shortened useful life expectancy. Soil absorption fields must be maintained properly to operate at peak efficiency. When failures occur, immediate repairs are essential to eliminate potential human health hazards and contamination of surface water and drinking water supplies.

Vehicles shall not be allowed to drive over any component of an onsite wastewater system. Vehicles including automobiles, pickups, or other equipment, may cause compaction and /or damage due to settling, shifting, or breakage of septic tank, piping, chambers, or other components. This can lead to sewage surfacing, creating a health hazard. Likewise, vehicles should not be used over any area that is to be or may be used for an onsite system. This includes areas that are intended for system installation in the near future as well as areas designated as reserve for future absorption fields.

Water Use

Water use patterns are the most critical factor in successful onsite wastewater treatment. For complete and uniform treatment of wastes, the onsite wastewater system needs time to work. If a large volume of water is used in a short period of time, the system can become hydraulically overloaded. Hydraulic overload may cause turbulence, washing solids and scum out into the absorption field. Solids and scum carried into the laterals quickly diminishes the life expectancy of the soil absorption system, causing premature failure. Homeowners should spread large water volume activities such as laundry and dishwashing over several days. Water use should be kept

as uniform as possible to allow the system the time needed to provide good treatment of the wastes.

The Effects of Water Softener Use on a Wastewater Treatment and Absorption System

A common concern by many homeowners, sanitarians, manufacturers, contractors, and scientists regards the effects of a home water softener on a septic tank and the soil absorption system. Home water softeners are based on the ion exchange principal where sodium on the exchange media replaces the calcium and magnesium hardness minerals in the water. This process gives the softened water a predominant sodium cation. Regeneration requires about 50 gallons and results in a sodium chloride brine flushing the calcium and magnesium from the softener media. Does the sodium in soft water and high salt concentration in the recharge adversely affect any part of the onsite system?

A study at the University of Wisconsin-Madison in 1978-79 confirmed previous government research from 1954. The findings of the earlier research were questioned because they seemed to contradict a large volume of research on irrigation. High sodium water has an undisputed adverse effect on soil structure and permeability especially in high clay soils. It is common knowledge that sodium on clay exchange sites causes some clays to swell, thereby reducing water's ability to seep readily through the soil.

Researchers found that the water softener regeneration brine did not reduce the percolation rate of water in the absorption field of a normally operating septic system. This conclusion was reached because the brine contains sodium, but it also includes significant amounts of calcium and magnesium. The calcium in the brine is thought to act similarly to gypsum, a calcium-rich substance routinely used to increase the porosity of clay soils in agriculture. The research report stated that calcium, therefore, helps counteract any negative effects of the sodium.

The Wisconsin study speculated that if all household water is softened and the softener recharge containing calcium and magnesium is not discharged into the onsite wastewater system, the absorption field soil may be irreversibly damaged by the predominately sodium cations in the household sewage. (Corey and Tyler, 1978)

A second research study by the National Sanitation Foundation (NSF) found that brine wastes had no negative effect on the bacterial population living in the aerobic treatment tank, even when the system was loaded with twice the normal amount of brine. The tests determined that water softener wastes actually help with the treatment processes. The NSF final report states that the wastewater has "a beneficial influence on a septic tank system." In other words, the researchers in this study found that microorganisms living and working in a home aerobic treatment system are not harmed by water softener salts. (NSF, 1978).

As with most scientific research, these two studies answered each of the proposed questions under the specific conditions of the project. It should be recognized that other variables exist that were not included in the studies. For instance, would the results be the same if a conventional anaerobic septic tank had been used in the NSF study? The Wisconsin study examined effects on a normally operating absorption system. Would there be a difference if the system had been installed in a marginal soil or was operating at capacity? The research

examined ideal conditions. Water softeners that malfunction or are not used correctly (i.e., timed to regenerate too frequently) have been known to cause problems.

It appears that more research should be done before conclusive statements are made about the effects of water softener regeneration brines on onsite systems. Ion exchange water softeners probably most affect septic systems that may be undersized, or are installed in marginal (clayey) soils. In addition, the hardness of the water is a factor in that very hard water (> 400 ppm) requires more frequent regeneration, with a greater potential for hydraulic overloading.

When there are concerns about a water softener creating septic system problems, an alternative is to soften only the hot water side. This provides soft water for most cleaning chores and the softness of the blended water may be quite satisfactory to the homeowner.

SEPTIC TANK MANAGEMENT AND MAINTENANCE

To slow sludge accumulation and prolong the time between pumping, septic tank users can make some adjustments in waste disposal. Use of garbage grinders is discouraged because they can nearly double the solids accumulation in the septic tank. Anything that is inert or slow to break down should not be put into the onsite wastewater system. See Table V- 2 for a list of things to avoid putting into the septic tank because they do not degrade well and thus increase the need for solids removal. The recent widespread use of antibacterial soaps may have an adverse effect on bacterial action in the septic tank and absorption field. Table V-3 lists common household hazardous materials that should not go into onsite wastewater systems because they are not degraded in the system and thus pose a risk to groundwater pollution.

Table V-2. Inert or Slow to Decompose Items that Should Not Go into a Septic Tank

Kitchen	Bathroom	General
<ul style="list-style-type: none"> • Coffee Grounds • Excessive Oils or Fats • Bones, Egg Shells • Wet-Strength Towel • Glass • Soil from Produce or Plants • Tough or Stringy Vegetables such as Onion Skins, Celery, Swiss Chard 	<ul style="list-style-type: none"> • Facial Tissue, Q-tips, Cotton Balls • Panty Liners, Tampons, Sanitary Napkins • Dental Floss • Condoms • Disposable Diapers • Hair • Bandages 	<ul style="list-style-type: none"> • Cigarette Filters • Dirt from Soiled Articles (sand, silt, or clay) • Fabric • Cat Litter • Strings and Thread Lint from Washer

Some materials can disrupt biological action in a septic tank. Other compounds are not easily degraded by onsite systems thus they risk contamination of the groundwater. Medications or **large** doses of disinfectants or other chemicals can disrupt biological processes in septic tanks. Normal household use of cleaning compounds for laundry, dishes, and household fixtures, can be safely put in the septic tank. **Leftover and unused portions of hazardous waste should never be put into a septic system.** Large quantities of the materials in Table V-3 should never be put in the onsite wastewater system.

Table V-3. Common Household Hazardous Waste

Rug and Upholstery Cleaners	Floor and Furniture Polish
Bleaching Cleaners	Mothballs
Pool Chemicals	Ammonia-based Cleaners
Abrasive Cleaners or Powders	Antifreeze
Transmission Fluids	Brake Fluids
Used Oils	Batteries
Household Batteries	Oven Cleaners
Toilet Cleaners	Photographic Chemicals
Disinfectants	Drain Cleaners
Arsenical Pesticides	Medications
Carbamate Pesticides	Chlorinated Hydrocarbons
Organophosphate Pesticides	Flea Collars and Sprays
Roach and Ant Killers	Rat and Mouse Poisons
Herbicides	Enamel or Oil Based Paints
Latex or Water Based Paints	Rust Paints
Paint Thinners and Turpentine	Furniture Strippers
Wood Preservatives	Wood Stains and Finishes
Plant Fertilizers – Especially Nitrogen	House Plant Insecticides
Fungicides	

Septic Tank Start-up

The optimum time of year to start operation of a septic system is in late spring or summer. The tank needs to be filled prior to use to check for leaks, allow for settling, and prevent the tank from floating to the surface in the event groundwater collects around the tank. The addition of hot water speeds the start-up process of bacterial action in the tank, especially if it has to be started in the winter.

Septic Tank Maintenance

The purpose of the septic tank is to remove and store solids, preventing them from being carried into the absorption field. A septic tank is designed with storage capacity to gradually accumulate sludge and floating scum, even with the most careful use. If the outlet baffle is damaged or the sludge or scum gets too close to the bottom of the baffle, solids are carried by the effluent into the absorption field, clogging pore spaces in the soil. Clogging soon results in system failure. At this point, the tank must be pumped and irreparable damage to the soil absorption field will likely have occurred. Rather than allowing this costly damage to happen, the homeowner or a qualified technician should inspect the system annually and when needed, have the tank contents pumped to prevent solids from being carried into the soil absorption field. An effluent filter as previously described is effective protection against solids flowing into the absorption field.

Effluent filters should be checked routinely based on the recommendations of the manufacturer and cleaned when necessary. Large capacity filter units probably do not need to be cleaned between tank pumping intervals. The smaller filters need at least annual inspection. In some cases, where the wastewater contains many solids, inspection should occur more frequently.

No additives are needed to begin the bacterial action in a tank. Sewage contains a very high concentration of bacteria, billions per ounce, and those best adapted will multiply in the system. The tank could be seeded with septage from another tank with similar conditions but this is not necessary.

There have been many products marketed that are supposed to “clean” a septic tank or help it function better. These materials have a wide range of properties. Some actually can harm the system by causing an increase in particle buoyancy or sludge bulking and carryover to the absorption field, which accelerates clogging. Another type of product contains solvents that dissolve oil and grease, the scum layer. Solvents are not degraded in the absorption field. Thus, they can contaminate the groundwater. No unbiased tests have shown substantial benefits of additives to the total system. Natural bacteria in domestic wastewater will begin the digestion process automatically as solids start to build up in the tank. Commercial “seeding” products are available to start the breakdown process, but they are not necessary. The homeowner or septic tank user should be advised, **do not use septic tank additives.**

Tank Inspection

Two things are measured when inspecting the tank: scum thickness and sludge depth. Figure V-5 shows the process of measuring the sludge and scum layers in a full septic tank. The sludge is quite liquid and the height of solids are detectable only by attachment of a very rough surface, like terry cloth wrapping, or by removing a column of water in a tube.

The sludge and scum should be checked in the first compartment and when pumping is needed, all chambers should be pumped, cleaned, and more fully examined for structural defects. The condition of the tank and baffles should be investigated in each chamber of a multi-compartment tank or series of tanks.

The condition of the tank's interior is best evaluated when it is empty, but scratching the reachable sides with a metal rod can give an indication of softened or corroded concrete even in a full tank. The condition of the baffles should be examined while the tank is open for inspection. Any apparent damage should be repaired immediately. This damage occurs most commonly in the air space above the liquid level where hydrogen sulfide gas combines with moisture, forming sulfuric acid. The acid attacks and degrades the concrete.

Figure V-5. Measuring Sludge and Scum in a Septic Tank

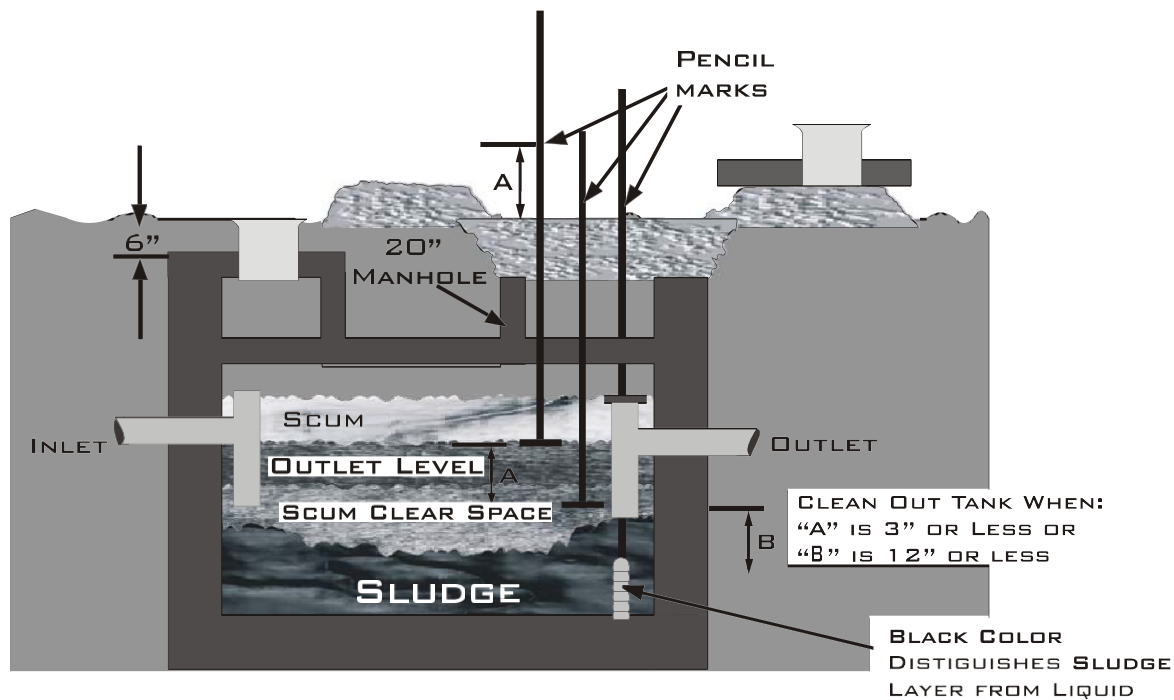

Septic Tank Pumpers

The condition of the piping, tank, and baffles should be checked at the time the tank is pumped. Occasionally, frost heave or differential settlement will move the house sewer line where it enters or leaves the tank, causing a crack or break in the pipe or joint. When this occurs in the influent line, solids may accumulate at the break, causing a clog that backs up sewage into the house.

The manhole, not the inspection port at the inlet or outlet end, should be used for pumping so that harm to the inlet or outlet baffles does not occur. All tank compartments are to be pumped. An approved septage hauler's fee should include pumping, inspection of the tank, and the proper

disposal of septage. The inlet and outlet baffles shall also be carefully checked to assure that they are in good condition when the tank is pumped.

The septic tank should NOT be scrubbed, or disinfected before it is used again, however, most pumpers will rinse out the tank to get a good look at the inside of the tank. A few inches of liquid (not sludge) may be left in the tank. The homeowner is advised to immediately refill the tank to reduce the risk of the tank floating. This is an acceptable time to do several loads of laundry or conduct other activities involving high indoor water use.

Septage Disposal

Septage is considered a public health hazard because of the many disease-causing organisms it may contain. Only companies or individuals approved by the county may engage in the pumping or cleaning of septic tanks or the transport of sewage. The county code should address certification of septic tank pumpers and the proper dispose of the septage. Disposal of septage shall be of in compliance with the US Environmental Protection Agency (EPA) Part 503 regulations. Approved septage haulers know how to manage septic tank waste. The homeowner should be informed about his/her responsibility to make sure that septic tank pumpage, or septage, is properly handled. He/she may be held liable for the improper disposal of household wastewater.

Septic Tank Abandonment

When a septic tank is discontinued from use, the tank must be removed or filled. The tank should be pumped completely to remove all solids and liquid. The best approach is to remove the tank at this point to avoid any potential future problems with later construction. If the tank will not be removed, it should be collapsed and the hole filled in. If not collapsed, the tank may be perforated with several holes drilled in the bottom of the tank. The tank should then be filled with stable fill material such as gravel, sand or other inert non-settling material. This avoids the danger of the tank collapsing later. Inlet and outlet pipes should be plugged at this time.

SEPTIC TANK SAFETY

Excavations for septic tanks can create a safety hazard. Experience shows that depths as shallow as five feet below ground level have resulted in injury and loss of life. The installer is responsible for assuring that working conditions on the site are not hazardous to workers or the public. An excavation deeper than 5 feet cannot be entered unless OSHA standards for the entry are met. Children, animals, and non-authorized personnel should be excluded from the work site. One should never use electrical lights, appliances, or tools in or close to the water or wet ground near the septic tank or drainfield because this can result in explosion or electrical shock.

Because the liquid and solid contents of the septic system are capable of causing infectious diseases, it is important to always wash hands thoroughly after working on any part of the septic system, and before eating, drinking, or smoking. Work clothes should be changed before entering a house, food store, or restaurant, etc. Smoking should be avoided near septic tank openings because combustible gases may be present.

SEPTIC TANK DESIGN STANDARDS

General Requirements

Required of all septic tanks, regardless of the construction material:

- 1) A recommended minimum liquid depth of three feet (distance from outlet invert to bottom of tank), but shall not exceed six feet. The effective inside length of rectangular tanks must not be less than 1.5 or greater than 4 times the effective inside width.
- 2) The tank, including all extensions to the surface, must be water tight and constructed of durable material that is not subject to excessive corrosion, decay, frost damage, or cracking. Steel septic tanks have a short life because of corrosion and are not acceptable. The top of all tanks shall be designed and constructed to support a minimum of 400 pounds per square foot (lbs/sq ft). When buried more than 2 feet deep, the top shall support an additional 100 lbs/sq ft. for each foot of soil or portion thereof in excess of 2 feet.
- 3) The openings of the tank (or top of the riser) should be at the surface and shall be no more than 12 inches below the finished grade. It shall be large enough for inspection, maintenance, and clean-out purposes. The opening or manhole shall be a minimum of 20 inches on the shortest dimension. Where the top of the tank must be more than 12 inches below finished grade, an extension collar shall be attached to bring the top within 12 inches of the surface. All below grade attachments to the tank, connections, riser, extensions and lid shall be water tight. When any opening larger than 8 inches extends to the surface, that opening shall be child and tamper resistant. Some examples include lids that weigh at least 65 pounds, or locks and anchors that are not removable without special tools.
- 4) There shall be a one inch clearance between the underside of the top of the tank and the top of all baffles and partitions or other adequate openings, to permit venting of gas from the tank through the house stack vent.
- 5) Space above the liquid line is required for that portion of the scum floating on the liquid. For tanks having straight, vertical sides, the distance between the top of the tank and the outlet invert should be at least 15 percent of the liquid depth, with a minimum of 7 inches. In horizontal cylindrical tanks, an area equal to approximately 12.5 percent of the total volume should be provided above the liquid level. This condition is met if the liquid depth (distance from outlet invert to bottom of tank) is equal to 85 percent of the diameter of the tank.
- 6) Sewage lines carrying solids from the source to the tank should have sufficient slope to maintain velocities that carry solids. For household lines, a slope of between 1 percent ($\frac{1}{8}$ inch per foot) and 2 percent ($\frac{1}{4}$ inch per foot) is generally considered essential. The last 15 feet of sewer line preceding the tank shall not slope more than 2 percent ($\frac{1}{4}$ inch per foot).

- 7) The invert of the inlet pipe shall be located at least three inches above the invert of the outlet when the tank is level. This space allows for momentary rise in liquid level during discharges to the tank. Liquid standing in the sewer line between the house and the septic tank causes solids accumulation and may cause stoppage or backup, and should be avoided.
- 8) The septic tank inlet shall be a sanitary tee, elbow, or long sweep elbow with a low head inlet or baffle to direct incoming sewage downward and prevent flow from disturbing the floating scum layer. It should extend at least 8 inches below the liquid level, but should not penetrate deeper than 20 percent of the liquid depth.
- 9) The length of the outlet device is important in that it must allow only clear effluent to leave the tank. It extends below the floating scum in the tank and ends above the sludge accumulation. If the length of the outlet "T" is improperly sized, the tank will require more frequent pumping to prevent scum from being carried out or sludge solids from being washed out with the effluent. The outlet device should generally extend below the liquid surface to a distance equal to 35 percent of the liquid depth. For horizontal or cylindrical tanks this distance should be reduced to 30 percent of liquid depth.
- 10) The dividing baffle in two-compartment tanks shall extend from the bottom of the tank to at least six inches above the liquid line. The openings in the dividing baffle may be any shape but must have a minimum dimension of two inches and a total area of at least 12 square inches. The opening is to be centered in the baffle and at a point equal to 35 percent of the total liquid depth (30 percent liquid depth for cylindrical tanks) from the water level.
- 11) Septic tanks shall have an access manhole (a minimum 20 inch dimension) for each compartment. If the manhole does not extend to surface grade, a small diameter (at least 2-inch diameter) pipe shall extend to surface from the cover to mark the location of the manhole. This pipe shall not penetrate the lid of the tank. Inspection risers at least 6 inches in diameter (large enough to easily remove and replace the effluent filter) shall extend to surface grade, centered over the inlet and outlet tees. All below grade attachments to the tank, connections, riser extensions, and lid shall be water tight. When any opening larger than 8 inches extends to the surface, that opening shall be child and tamper resistant. Examples include lids weighing at least 65 pounds and locks, or anchors that are not removable without special tools.
- 12) The sewer line from the house to the tank, all fittings and pipe in the tank, all extensions to the surface from the top of the tank and the first 10 feet exiting the tank shall be schedule 40 pipe or heavier. Septic tanks shall be designed for at least a 20-year life. They shall be designed and constructed to withstand extremes in loads resulting from adverse conditions without excessive deflection, deforming, creep, cracking, or breaking. Change in shape shall be limited to 5 percent. Loads shall be based on 62.4 pounds per cubic foot for water and water-saturated soil. Top loads for design shall be 400 pounds per square foot plus 2,500 pound axle point load. Design shall be based on a 2 foot placement depth to top of the tank. If the tank will be placed deeper than 2 feet or subject

to vehicular traffic over the tank, a design by a Kansas licensed structural engineer shall be done for the specific conditions.

13) Refer to Table V-1 for minimum septic tank capacities

Special Considerations for Concrete Tanks

The anaerobic environment of a septic tank produces gases that combine with moisture to produce acids. Concrete above the liquid level is subject to corrosion and deterioration from these acids. This corrosion is best resisted by high quality concrete mix. Concrete septic tanks shall meet the following requirements, in addition to those above:

- 1) The concrete design mix shall have a compressive strength of at least 4,000 pounds per square inch at a 28 day cure. The water-cement ratio shall not exceed 0.45.
- 2) Baffles or other interior concrete units must be cast or built into the tank wall at the time the tank is constructed.
- 3) Air entrainment additives shall be added to 5 percent volume. Other chemical mixtures are encouraged to reduce water content, improve cement placement in forms, and for wet handling of incompletely cured concrete.
- 4) Concrete tanks and lids shall receive proper care during the hydration (hardening) period by: 1) monitoring and controlling temperature of the concrete and gradients (i.e. maintain 50-90 degrees Fahrenheit for conventional cure and up to 140 degrees Fahrenheit under low pressure steam cure) and 2) monitoring and controlling humidity to prevent adverse moisture loss from fresh concrete (i.e. prevent or replenish loss of essential moisture during the early, relatively rapid stage of hydration).
- 5) Reinforcing steel shall be placed as designed by a Kansas licensed structural engineer to ensure floor, wall, and top do not crack from moisture, frost, soil load, water loads, axle loads, or other stresses. Loads as specified above shall be used for the design condition. Reinforcing steel shall be covered by a minimum of 1 inch of concrete and shall be placed within $\pm 1/4$ inch.
- 6) Pouring the floor and walls of the septic tank at the same time (monolithic pour) is the preferred construction procedure. Very large tanks are often cast in 2 pieces and assembled in the field. All tanks shall meet the same structural strength standard as specified earlier. Two-piece tanks shall have permanently sealed, structurally sound joints and shall be water tested after assembly. A Kansas licensed structural engineer shall determine if the tank meets the strength specification.
- 7) In areas of high sulfate water (greater than 250 mg/L) more acid producing gases are likely and additional corrosion resistance is appropriate. Recommended measures include ASTM C150 Type II cement (moderate sulfate resisting), ASTM C150 Type V cement (highly sulfate resisting), or coating interior concrete surfaces above the water line. Coatings that provide additional protection of the concrete include asphalt, coal tar, or epoxy. The product used should be acid resistant and provide a moisture barrier coating

for the concrete. The product must not bleed into the water, risking groundwater contamination.

- 8) Manufacturers are strongly urged to follow guidelines and meet the standards of the American Concrete Institute, National Precast Concrete Association, and American Society for Testing and Materials. Manufacturers should identify and advertise their products which meet these applicable standards.

Special Considerations for Fiberglass and Plastic Tanks

- 1) All tanks shall be sold and delivered by the manufacturer, completely assembled.
- 2) Tanks shall be structurally sound and support external forces as specified above when empty and internal forces when full. Tanks shall not deform or creep, resulting in deflection more than 5 percent in shape due to the loads imposed.
- 3) Tanks, all below grade fittings, and connections including inlet and outlet pipe and risers shall be watertight.

SEPTIC TANK PLACEMENT SPECIFICATIONS

- 1) The vehicle setting the tank must not enter the absorption field area during the process of placing the tank, as heavy traffic compacts the soil.
- 2) Where natural soil is not suitable, tanks shall be placed on a bed of at least 4 inches of sand, pea gravel, or crushed granular noncorrosive material for proper leveling and bearing. Material shall be no larger than 2 inches in diameter and bed depth shall be at least four times the diameter of the largest material.
- 3) Access manholes should be at surface grade, but shall not be more than 12 inches below surface grade. Where the top of the tank must be more than 12 inches below surface grade, a watertight collar and extension riser shall be added as necessary to raise the cover. Inspection openings placed over inlet and outlet tees or baffles shall be at least 6 inches in diameter and extend to the surface. This simplifies locating the tank and makes it easy to inspect and clean the effluent filter, check the condition of tees or baffles, and measure sludge accumulation.
- 4) Septic tanks should not be placed into the water table (including perched or seasonal water table) because of the tendency of the tank to float. This is especially of concern when the tank is empty after being pumped; the displaced volume of the tank has a buoyant effect. Septic tanks should not be completely emptied if groundwater levels are significantly higher than the bottom of the tank. For existing tanks in any area subject to high water table or seasonally high water table, replacement tanks of plastic and fiberglass shall not be used unless precautions are taken to drain groundwater.
- 5) Septic tanks shall be watertight. An adequate test for this is to fill the tank with water and let it stand for 8 hours to allow concrete to absorb water and for plastic tanks to adjust. The tank is then topped off and an initial measurement is made with a hook gauge with Vernier scale, followed by another measurement an hour later. Any water loss

shows water leakage and the tank should be rejected. Observations of the outside of the tank can also give clues about leakage losses. Any trickle, ooze, or exterior wet spot is reason to reject the tank. Precast, one-piece tanks are best tested at the plant before delivery. Two-piece tanks that are assembled on-site must be tested following placement but before back filling.

- 6) The hole for the tank shall provide ample space around the tank that allows access for proper compaction. Backfill should surround the tank in uniform, compacted layers not exceeding 2 feet thick. Care must be taken during the installation and backfilling of fiberglass and plastic units to prevent damage to the tanks. The manufacturer's installation instructions must be followed, and usually includes filling the tank with water as it is backfilled. If the natural soil does not crumble easily, these tanks should be backfilled with sand. Medium to small-grained granular materials are the best fill around the tank's ribbing to provide consistent support. Because of potential soil collapse, it is unsafe and can be illegal for a person to enter a trench deeper than 5 feet without adequate shoring. Compaction should be done from the surface without entering trenches deeper than 5 feet.
- 7) Special care must be taken in bedding the house sewer, septic tank, and outlet line to prevent uneven settlement, resulting in cracked or ruptured pipe at the point where the inlet and outlet lines connect with the septic tank. Shorter pipe lengths at the inlet and outlet also help to minimize this problem.

REFERENCES AND ADDITIONAL READING

Corey, R.B., and E.J. Tyler. *Effects of Water Softeners on the Permeability of Septic Tank Soil Absorption Fields*, Champaign, Illinois, 1978.

National Small Flows Clearinghouse, Pipeline Quarterly, *Softener Use Raises Questions for System Owners*, Winter 2001, Volume 12, Number 1.

National Sanitation Foundation. *The Effect of Water Softener Waste Regeneration Brines on Individual Aerobic Treatment Plants*, July 1978.

National Small Flows Clearinghouse, Pipeline Quarterly, *Septic Tank Enhancements*, Fall 2003, Volume 14, Number 4.

Publications Regarding Basic Pretreatment – Available from K-State Research and Extension

Septic Tank Maintenance: A Key to Longer Septic System Life, MF-947

Why Do Onsite Wastewater (Septic) Systems Fail? MF-946

Publications Out of Print but Available from Extension Biological and Agricultural Engineering, 147 Seaton Hall, Kansas State University, Manhattan, Kansas 66506.

Household Product Disposal Guide, MF-965