

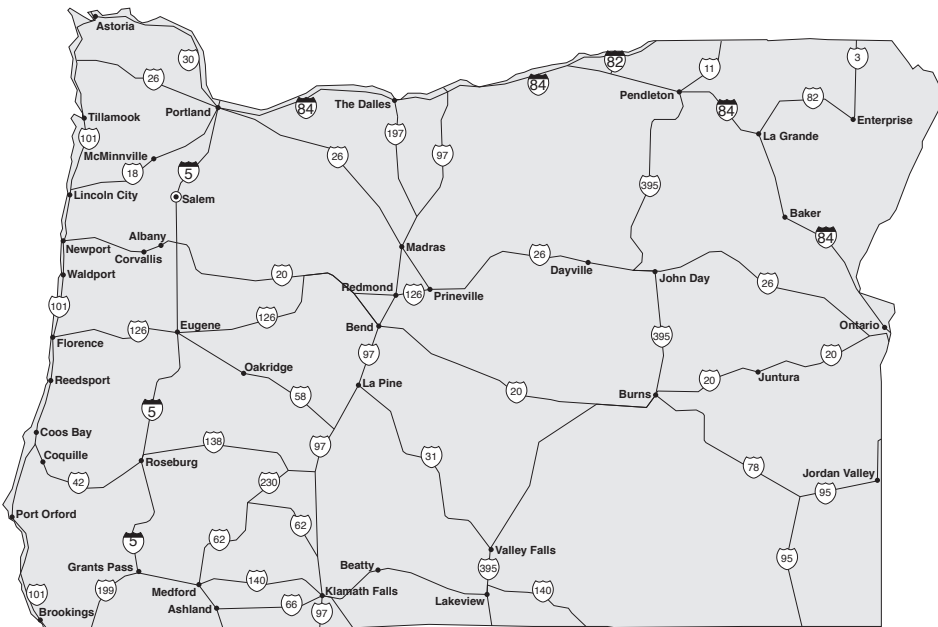

INFILTRATOR®
water technologies

Design and Installation Manual for Infiltrator Quick4 Chambers in Oregon



Oregon



Infiltrator Chambers in Oregon

INTRODUCTION	2
PRODUCTS	4
CHAMBER CONFIGURATIONS	6
INSTALLATION INSTRUCTIONS	15
PRESSURE DISTRIBUTION	17
CAPPING FILL	18
SAND FILTER ABSORPTION SYSTEMS	20
WARRANTY	22

The purpose of this product design manual is to provide specific design and installation information pertinent for the use of Infiltrator Quick4 chambers in Oregon.

For more detailed design information, please contact
Infiltrator Water Technologies at 1-800-221-4436

Oregon

INTRODUCTION

The purpose of this manual is to provide the minimum design and installation information for the use of Quick4® Equalizer® 24, Quick4 Equalizer 24 Low Profile (LP) and Quick4 Equalizer® 36 chambers in Oregon. Exceptions and changes may be made, but should be confirmed by Infiltrator Water Technologies and the Oregon Department of Environmental Quality. Each revised version of this manual supersedes the previous version.

The manual provides a brief description of each chamber model including sizing specifications. For more detailed design information, please contact Infiltrator Water Technologies at 1-800-221-4436 or your local Oregon Infiltrator representative.

Special Installation Instructions

If your area is prone to ground-burrowing rodent activity, Infiltrator suggests combining our standard installation instructions with our ground-burrowing rodent protocol. Further information can be acquired by contacting your local Infiltrator distributor.

Quick4 EQ24 Chambers

The Quick4 Equalizer 24 chambers can be installed in an 18-inch-wide or 24-inch-wide trench. There are a variety of system inletting options to choose from, with and without a distribution box.

Quick4 Equalizer 24 Nominal Chamber Dimensions

Size:	16"W x 48"L x 11"H
Storage Capacity:	20.4 gal
Invert Elevation:	6"

QUICK4 EQUALIZER 24



Quick4 EQ36 Chambers

The Quick4 Equalizer 36 chamber can be installed in a 24-inch-wide or 30-inch-wide trench. There are a variety of system inletting options to choose from, with and without a distribution box.

Quick4 Equalizer 36 Nominal Chamber Dimensions

Size:	22"W x 48"L x 12"H
Storage Capacity:	32 gal
Invert Elevation:	6"

QUICK4 EQUALIZER 36



Quick4 EQ24 LP Chambers

The Quick4 Equalizer 24 Low Profile (LP) chambers can be installed as a gravelless absorption system. The chambers can be installed in an 18-inch-wide or 24-inch-wide trench, with a minimum soil cover of 4 inches.



Quick4 Equalizer 24 LP Nominal Chamber Dimensions

Size:	16"W x 48"L x 8"H
Storage Capacity:	21 gal
Invert Elevation:	2"

QUICK4 EQUALIZER 24 LOW PROFILE (LP)



INTRODUCTION

Infiltrator IM-Series Tanks			
Tank			
	IM-540	IM-1060	IM-1530
Applications	Suitable for use as a dosing tank or rainwater storage tank, in shallow, multiple, and serial tank configurations.	Suitable for use as a dosing septic tank, 2-compartment septic tank or rainwater storage tank, in shallow, multiple, and serial tank configurations.	Suitable for use as a dosing septic tank, 2-compartment septic tank or rainwater storage tank, in shallow, multiple, and serial tank configurations.
Working Capacity	gal	1,094 gal	1,537 gal
Total Capacity	552 gal	1,287 gal	1,787 gal
Airspace		16.5%	16.9%
Length	65"	127"	176"
Width	62"	62.2"	62"
Length-to-Width Ratio	1 to 1	2.3 to 1	2.8 to 1
Height	55"	54.7"	55"
Liquid Level	"	44"	44"
Invert Drop	3"	3"	3"
Fiberglass Supports	0	2	4
Compartments	1	1 or 2	1 or 2
Minimum Burial Depth	6"	6"	6"
Maximum Burial Depth	36"	36"	36"
Maximum Pipe Diameter	4"	6"	4"
Weight	169 lbs	320 lbs	501 lbs

PRODUCTS

Quick4 Equalizer 24 Chamber

SIDE AND END VIEWS (not to scale)

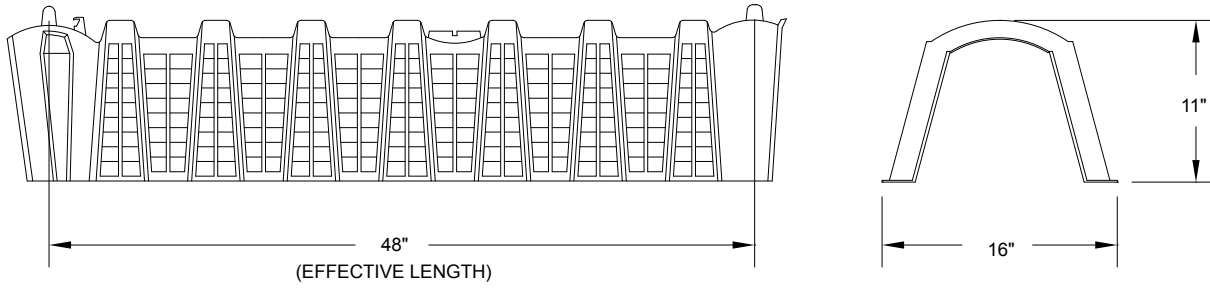

Quick4 Equalizer 24 Endcap

END VIEW (not to scale)

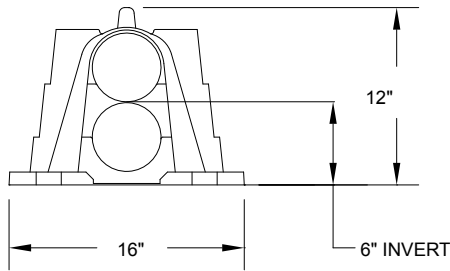

Inlet Adapter (not to scale)

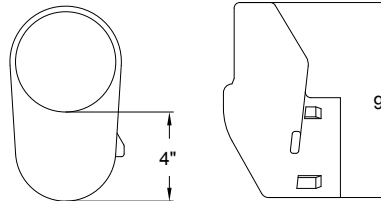

Quick4 Equalizer 36 Chamber

SIDE AND END VIEWS (not to scale)

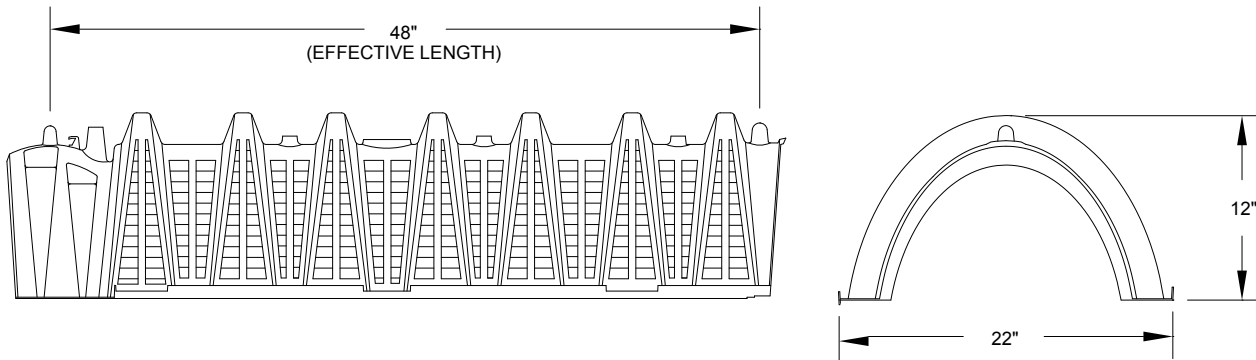

Quick4 Equalizer 36 Multiport Endcap

END VIEW (not to scale)

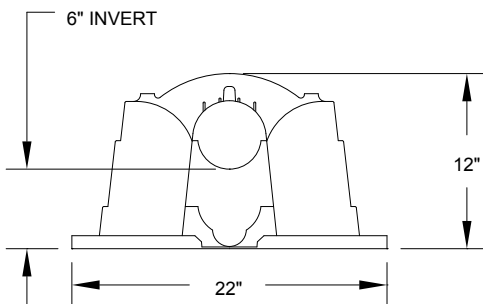

Inlet Adapter (not to scale)

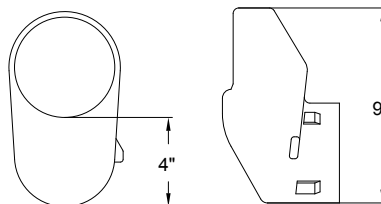

PRODUCTS

Sizing of Quick4 Equalizer 24, Quick4 Equalizer 24 LP and Quick4 Equalizer 36 Chamber Systems

Number of Quick4 Chambers	Linear Feet
113	452
100	400
88	352
75	300
69	276
63	252
57	228
50	200
38	152

CHAMBER CONFIGURATIONS – TRENCH

Quick4 Equalizer 24 Trench Configurations CROSS SECTION (not to scale)

Chamber Rating: 2 ft² per linear foot

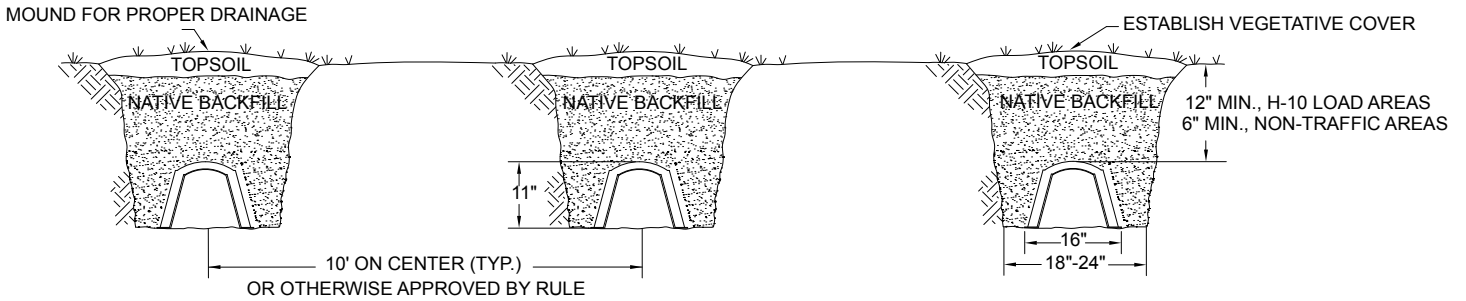

NOTE: The Quick4 Equalizer 24 is 16" wide and can be installed in a 18"-24" wide trench.

TYPICAL QUICK4 EQUALIZER 24 SIDE VIEW (not to scale)

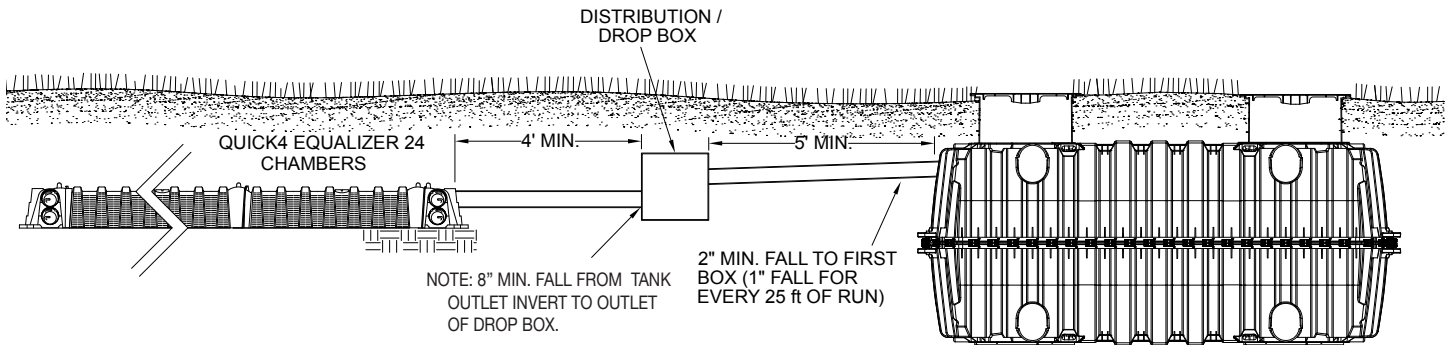

NOTE: The effluent sewer must extend at least 5 feet beyond the septic tank before connecting to the distribution unit. It must be installed with a minimum fall of 4 inches per 100 feet and at least 2 inches of fall from one end of the pipe to the other. In addition, there must be a minimum difference of 8 inches between the invert of the septic tank outlet and either the invert of the header to the distribution pipe of the highest lateral in a serial distribution field or the invert of the header pipe to the distribution pipes of an equal distribution absorption field. A minimum 18-gauge, green-jacketed tracer wire or green color-coded metallic tape must be placed above the effluent sewer pipe.

CHAMBER CONFIGURATIONS – SERIAL DISTRIBUTION

Approved System Designs

Infiltrator chambers using gravity-fed serial distribution methods may be laid out with the same-end inlet, center inlet, or alternate-end inlet. The figures on pages 7 through 11 illustrate some of these typical design options.

Note: Use of drop boxes is recommended by the Oregon DEQ.

Note: Drawings are for the Quick4 Equalizer 24 chambers. All Quick4 Equalizer 24 design applications also apply to the Quick4 Equalizer 36 chamber and not the Quick4 Equalizer 24 Low Profile (LP) chambers.

SERIAL DISTRIBUTION SAME-END INLET WITH DROP BOXES

PLAN VIEW (not to scale)

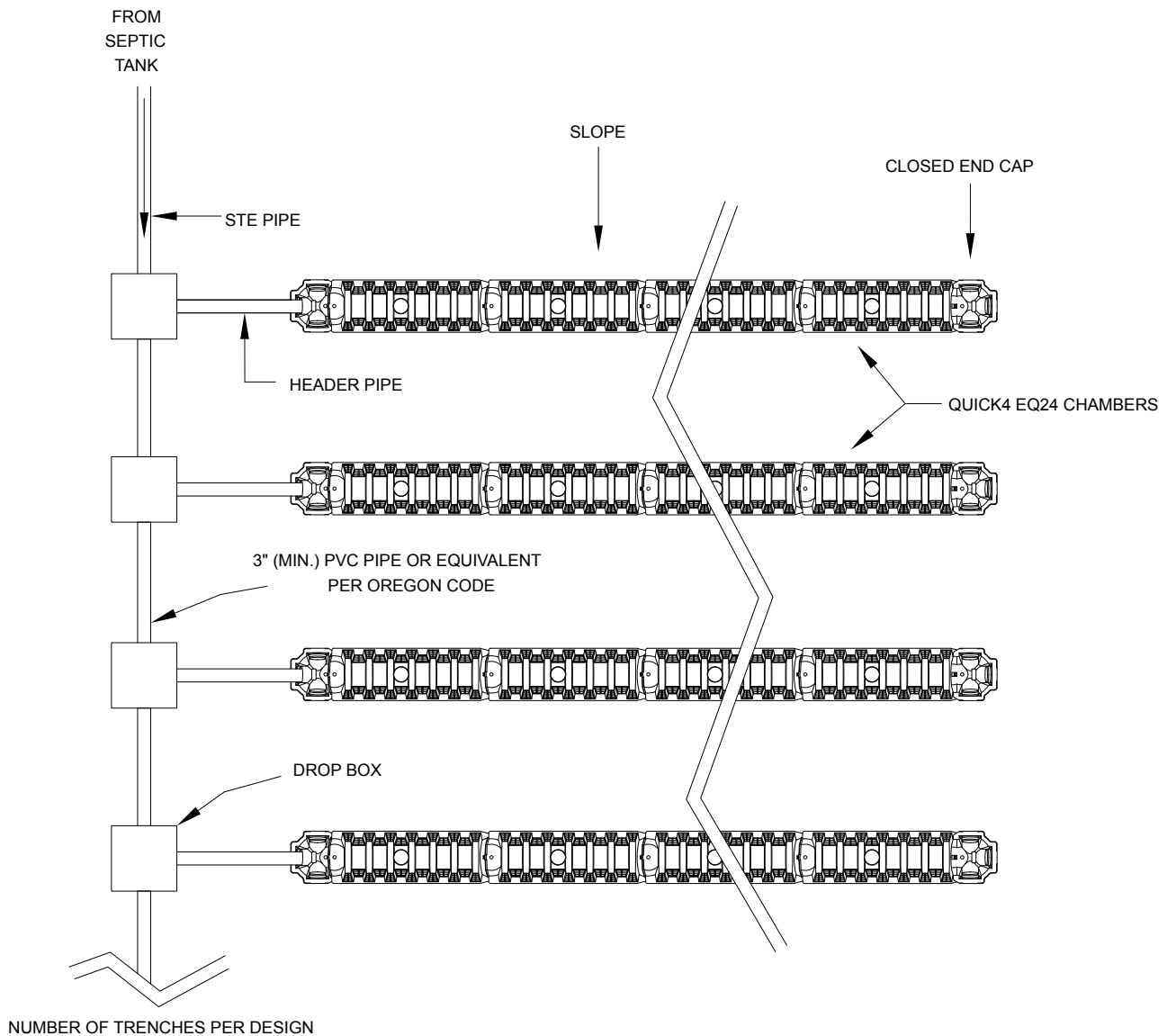

CHAMBER CONFIGURATIONS – SERIAL DISTRIBUTION

SERIAL DISTRIBUTION SAME-END INLET WITHOUT DROP BOXES

PLAN VIEW (not to scale)

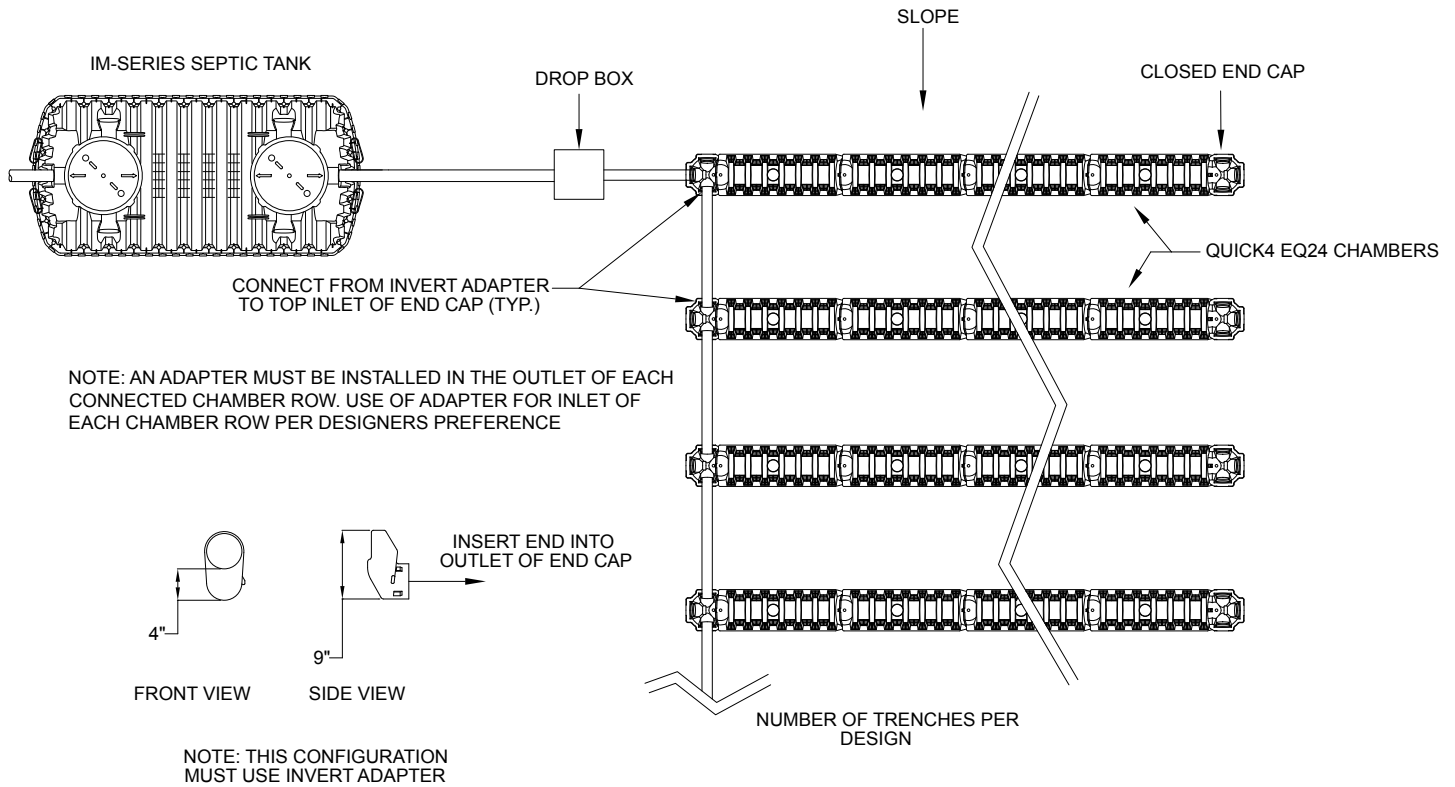

SERIAL DISTRIBUTION ALTERNATE-END

PLAN VIEW (not to scale)

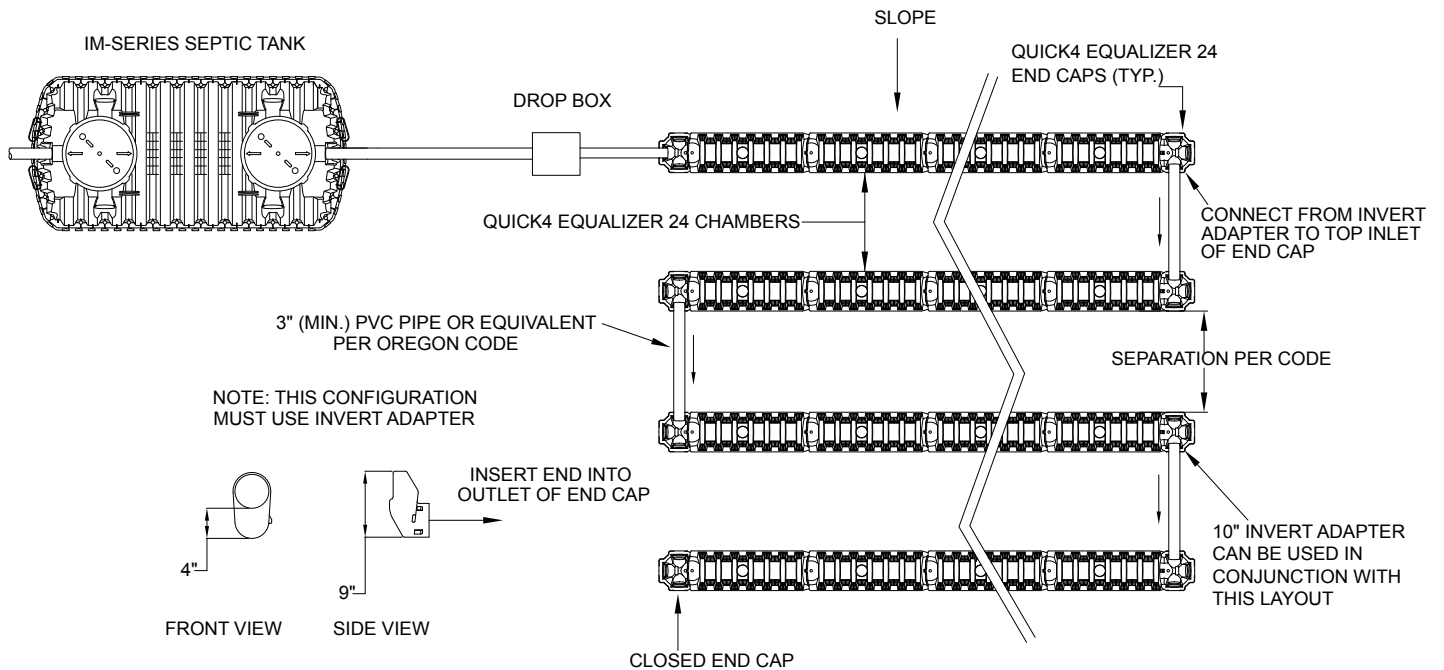

CHAMBER CONFIGURATIONS – SERIAL DISTRIBUTION

Using the Same-End and Center Inlet Serial Drop Box Method, create a 4-1/4-inch hole in the end cap at a 6-inch invert. Place drop box so header pipe is level.

Note: Drawings are for the Quick4 Equalizer 24 chambers. All Quick4 Equalizer 24 design applications also apply to the Quick4 Equalizer 36 chamber.

SAME-END AND CENTER INLET SERIAL DROP BOX (PREFERRED BY OREGON DEQ)

SIDE VIEW (not to scale)

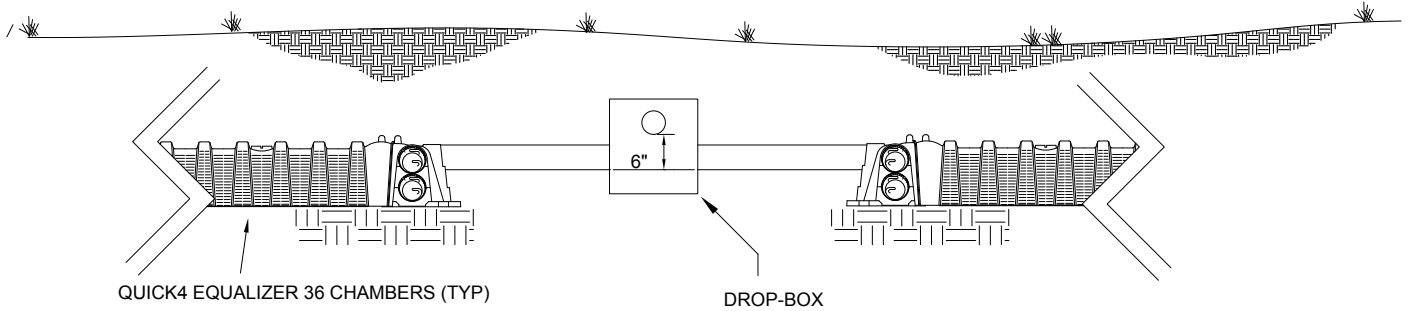

NOTE: The use of drop box is recommended by Oregon DEQ.

SERIAL DISTRIBUTION CENTER INLET

PLAN VIEW (not to scale)

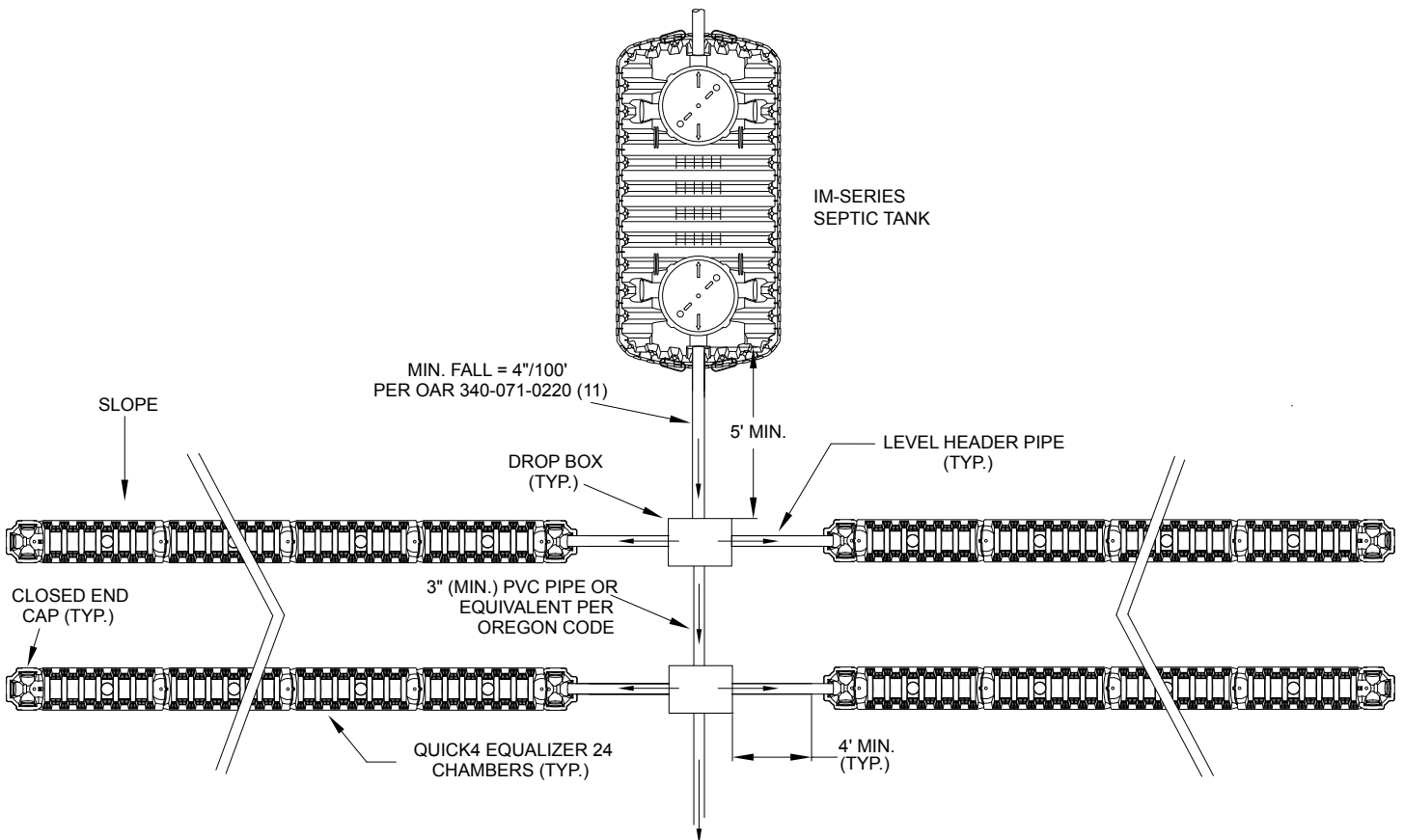

CHAMBER CONFIGURATIONS – SERIAL DISTRIBUTION

QUICK4 EQUALIZER 24 WITH 10" INVERT ADAPTER TRENCH DETAIL CROSS SECTION (not to scale)

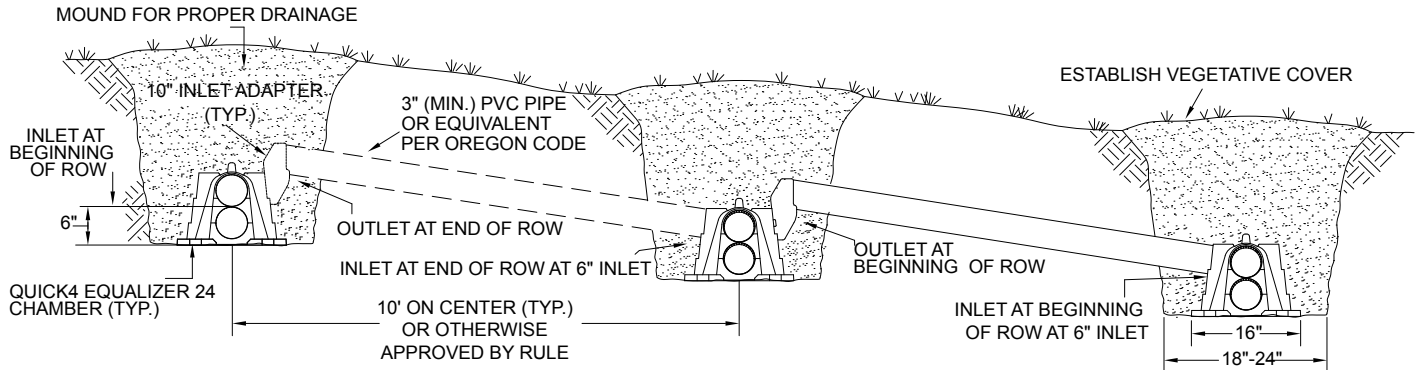

NOTE: THE QUICK4 EQUALIZER 24 IS 16" WIDE
AND CAN BE INSTALLED IN A 18"-24" WIDE TRENCH

*NUMBER OF ROWS DETERMINED BY DESIGN

CHAMBER CONFIGURATIONS – EQUAL DISTRIBUTION

Infiltrator chamber systems may also be designed using equal distribution methods. These require a distribution box or must be pressure dosed.

Note: All installations require 8 inches (minimum) of fall from the invert of the septic tank outlet to the invert of the Quick4 MultiPort Endcap.

Note: Drawings are for the Quick4 Equalizer 24 chambers. All Quick4 Equalizer 24 design applications also apply to the Quick4 Equalizer 36 chamber.

PLAN VIEW (not to scale)

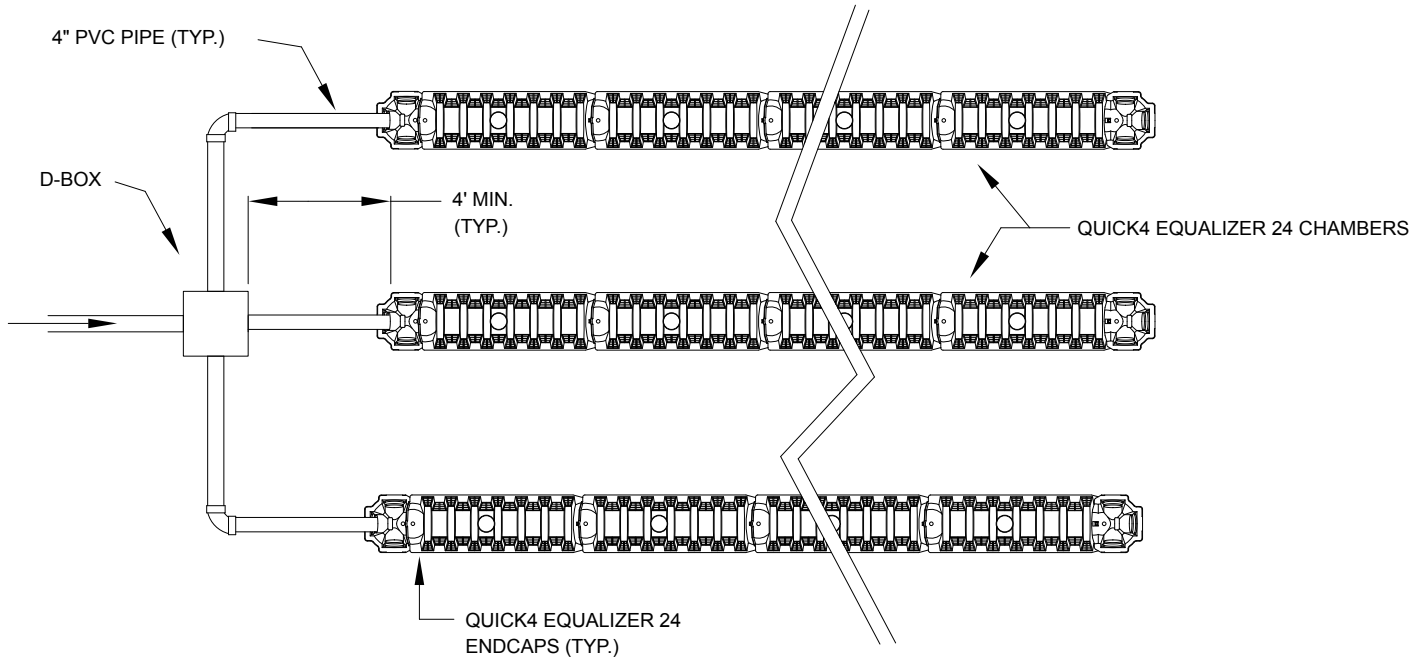

LOOP SYSTEM PLAN VIEW (not to scale)

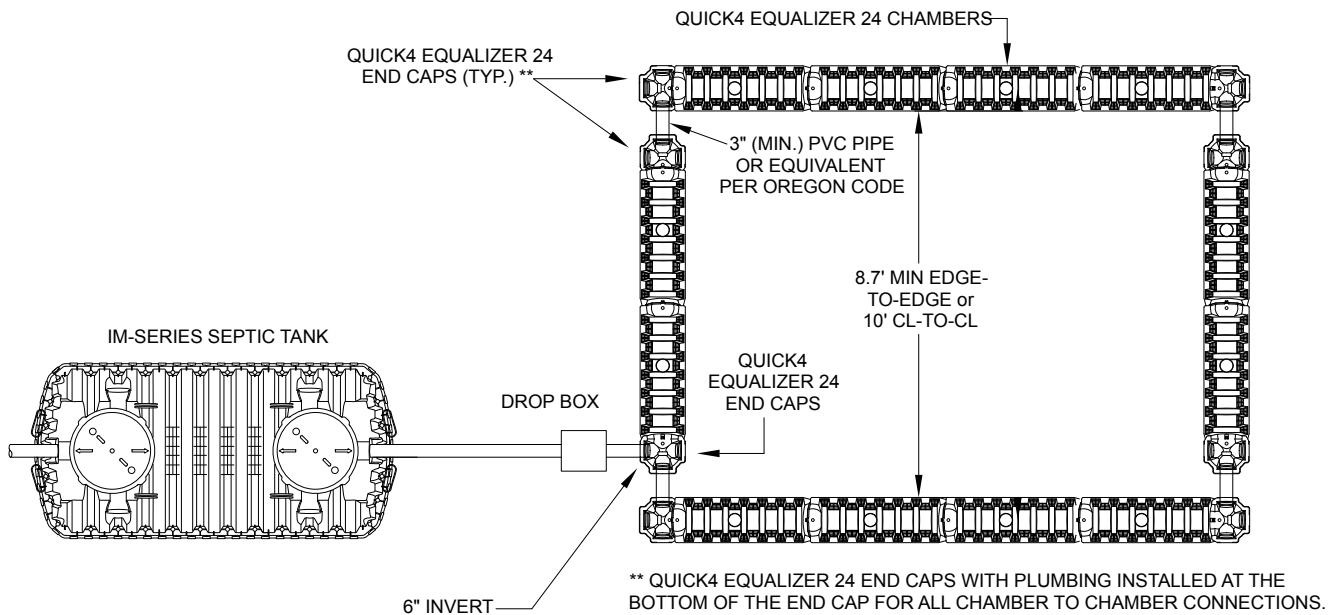

CHAMBER CONFIGURATIONS – PRESSURE DISTRIBUTION

Pressure distribution (PD) systems are commonly used in rapidly draining soil where vertical separation between the water table and/or restrictive layer is required. One-to two-inch pipe, commonly SCH40, with orifices at the 12 o'clock position, allow effluent to spray off the inside chamber dome, providing more even distribution.

See page 17 for specific Pressure Distribution Installation Instructions. The Quick4 Equalizer 24 chambers and Quick4 Equalizer 36 chambers may be used in pressure distribution systems.

When constructing a PD system:

- Pipe, pump and orifice sizing is determined through design specifications
- Laterals may be suspended using plastic pipe hangers, 12-inch plastic zip ties, or supported using pipe support units
- Drain orifices and shields at the 6 o'clock position are recommended in cold climates
- Accessible 90-degree sweep cleanout extensions are installed at the end of each lateral

PLAN VIEW (not to scale)

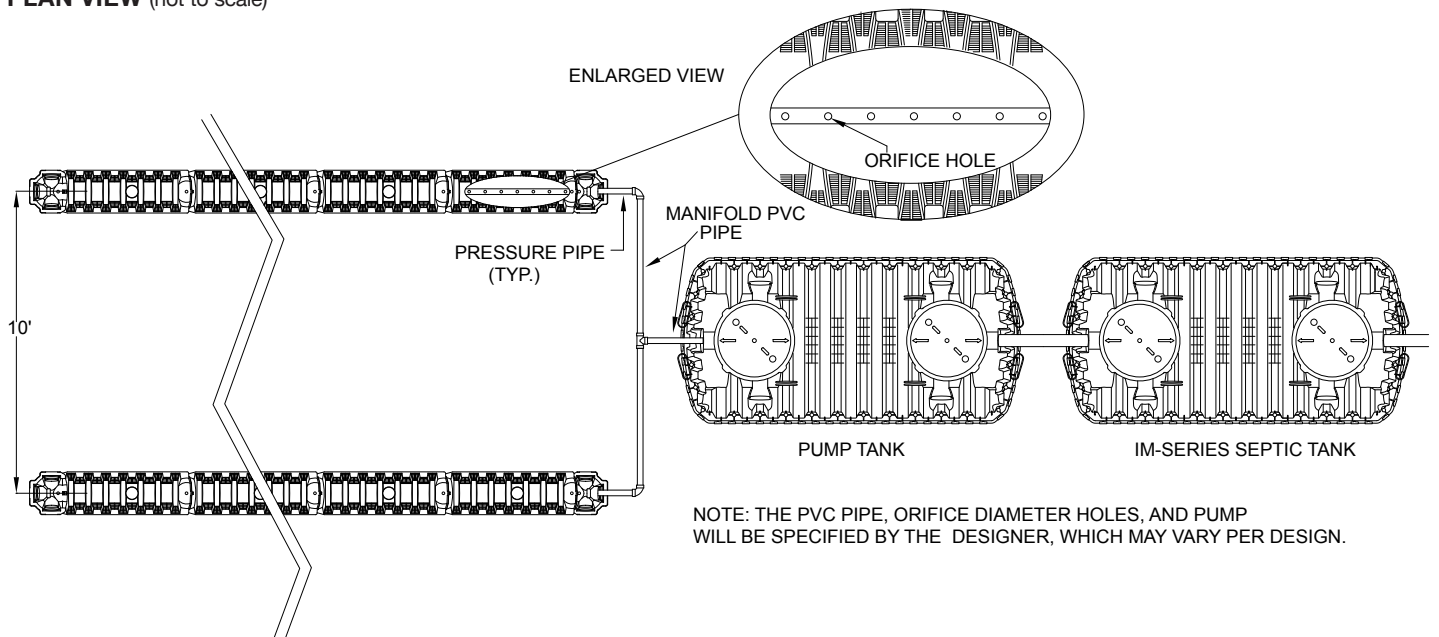

SIDE VIEW (not to scale)

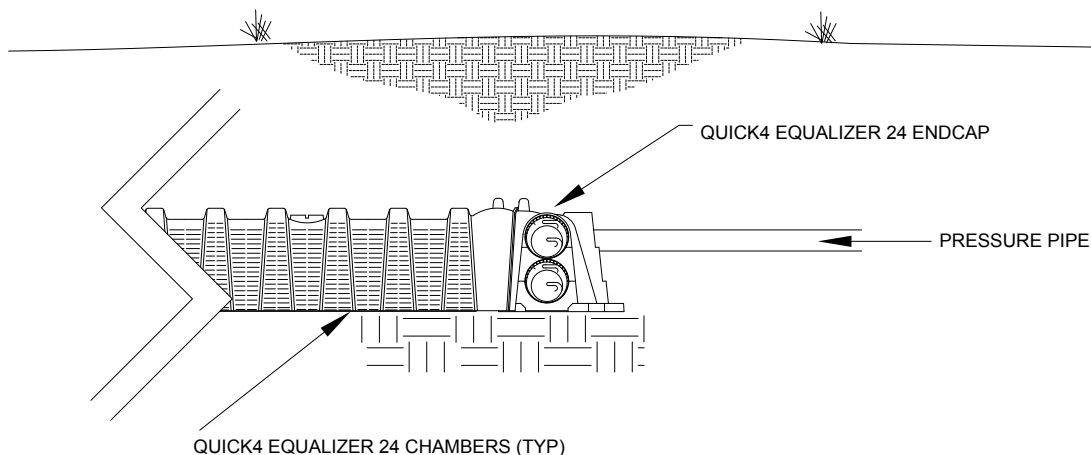

CHAMBER CONFIGURATIONS – PRESSURE DISTRIBUTION

PIPE ON GROUND METHOD END VIEW

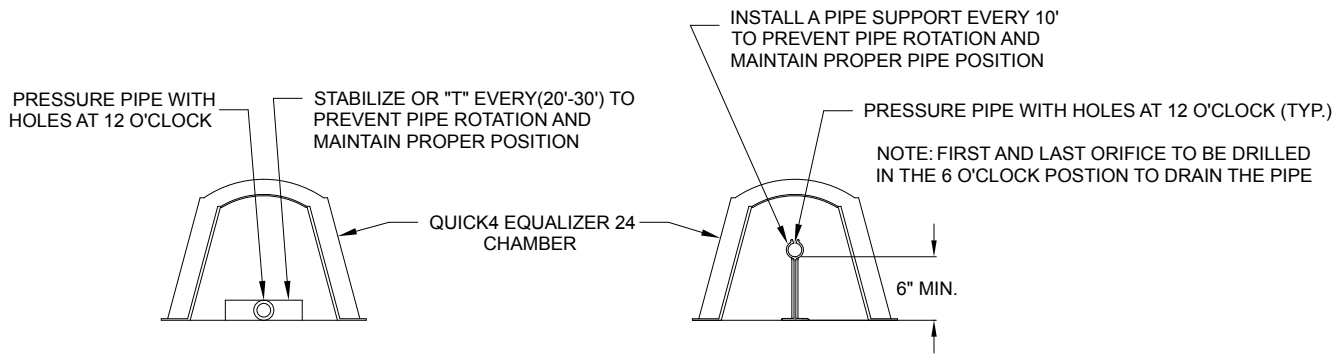

CLEANOUT EXTENSION DETAIL SIDE VIEW

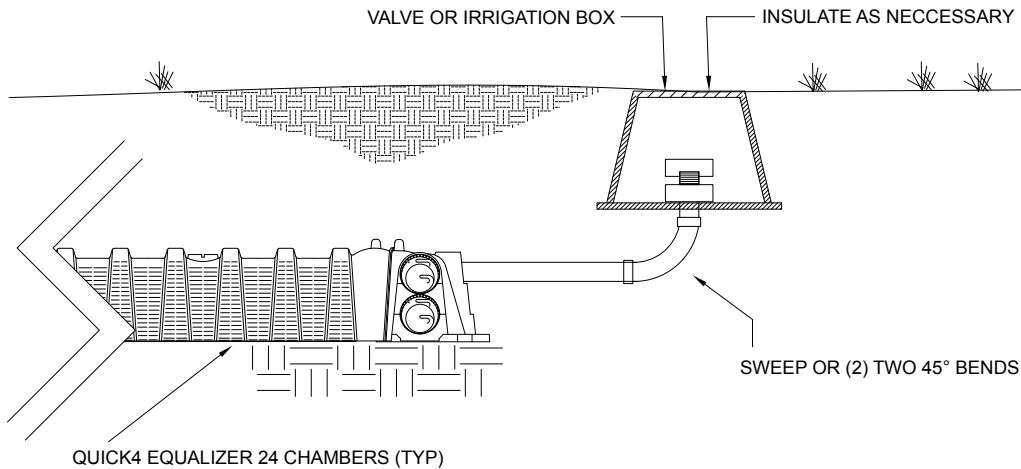

QUICK4 EQUALIZER 24 OPTIONAL INSPECTION PORT DETAIL (RECOMMENDED BY DEQ)

Note: All Infiltrator chamber models may be designed for this application.
 Note: The DEQ recommends a monitoring port at the end of each line.

OPTION A: CHAMBER RISER TO GRADE

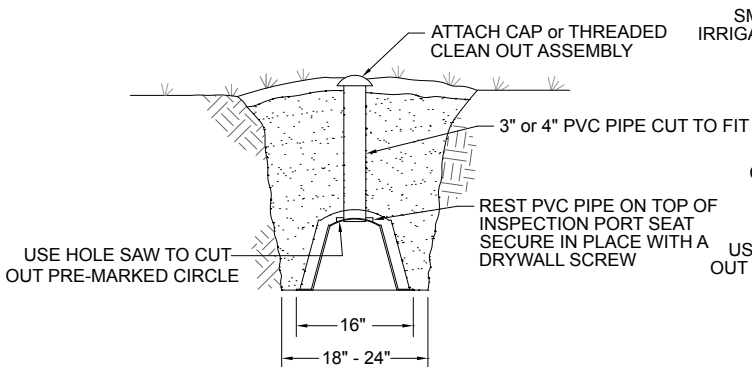

OPTION B: INSTALLATION WITH VALVEBOX

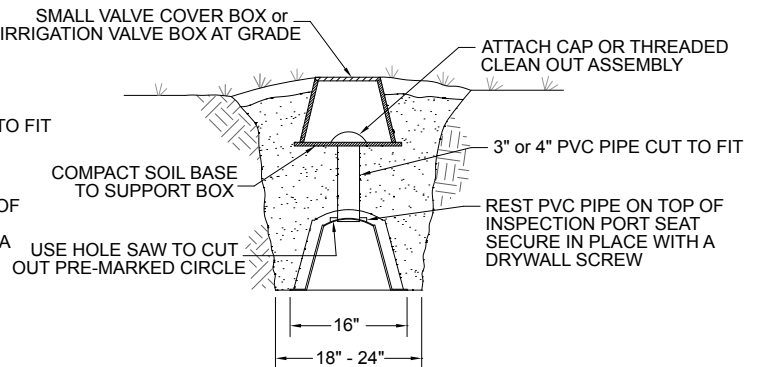

CHAMBER CONFIGURATIONS – TURN DESIGN CONFIGURATIONS

Contour Swivel Connection™

The Quick4 Chambers' Contour Swivel Connection allows systems to be constructed on sloped sites and avoid obstructions without additional parts or accessories. The chamber easily follows contours or an "S" curve and avoids obstacles without additional parts or accessories. Each chamber connection swivels 15-degrees right or left (see drawing below).

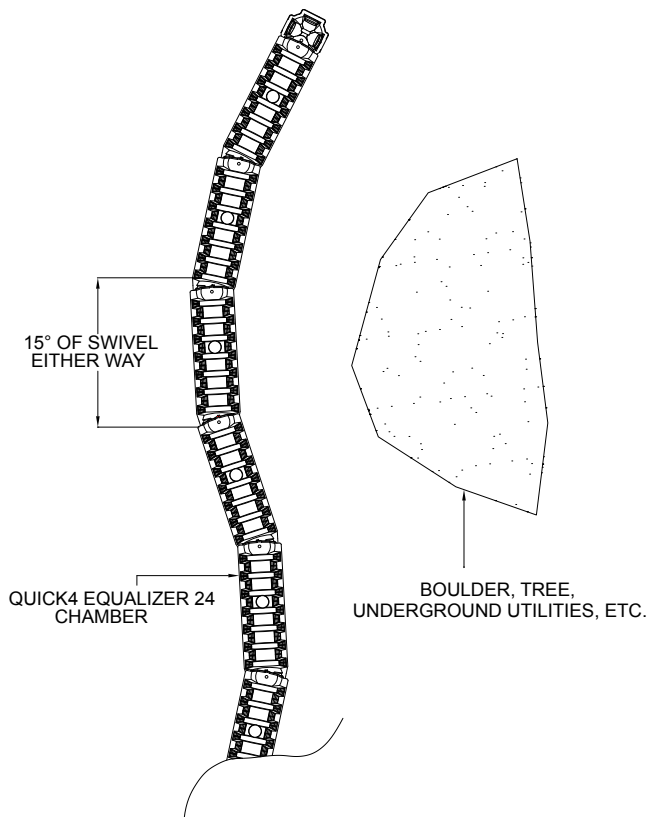

PVC Pipe with MultiPort™ Endcap

The Quick4 MultiPort End Cap's universal six-port design offers unlimited piping and design options. The molded-in inlets/outlets allow for maximum piping flexibility (must use bottom inlet in end cap).

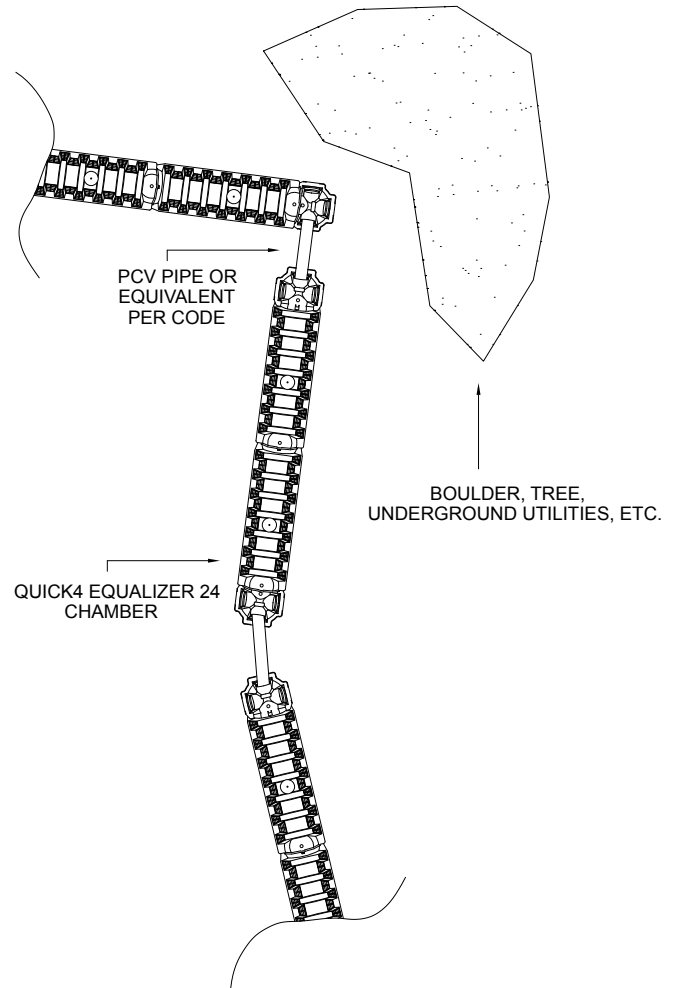

INSTALLATION INSTRUCTIONS – QUICK4 EQUALIZER 24 CHAMBER SYSTEMS

Before You Begin

Quick4 Equalizer 24 Chambers may only be installed according to State and/or local regulations. If unsure of the installation requirements for a particular site, contact the local health department.

Like conventional systems, the soil and site conditions must be approved prior to installation. Have your local regulator conduct a thorough site evaluation to determine the proper sizing and siting of the system before installation.

Materials and Equipment Needed

- | | |
|---|--|
| <input type="checkbox"/> Quick4 Equalizer 24 Chambers | <input type="checkbox"/> 1-1/4-inch Drywall Screws |
| <input type="checkbox"/> Quick4 MultiPort Endcaps | <input type="checkbox"/> Screw Gun |
| <input type="checkbox"/> PVC Pipe and Couplings | <input type="checkbox"/> Hole Saw* |
| <input type="checkbox"/> Backhoe | <input type="checkbox"/> Small Valve-Cover Box |
| <input type="checkbox"/> Laser, Transit, or Level | <input type="checkbox"/> 4-inch Cap for Inspection Port* |
| <input type="checkbox"/> Shovel and Rake | <input type="checkbox"/> Invert Adapter* |
| <input type="checkbox"/> Tape Measure | |
| <input type="checkbox"/> Utility Knife | *Optional |

These guidelines for construction machinery must be followed during installation:

- Avoid direct contact with chambers when using construction equipment. Chambers require a 12-inch minimum of compacted cover to support a wheel load rating of 16,000 lbs/axle or equivalent to an AASHTO H-10 load rating.
- Do not drive over trenches. If unavoidable use a tracked vehicle. Never drive down the length of the trenches.
- Onsite rules do not allow for vehicular traffic over drainfields. Compaction may affect performance even if it does not damage the product.

Excavating and Preparing the Site

Note: As is the case with conventional systems, do not install the systems in wet conditions or in overly moist soils, as this causes machinery to smear the soil.

1. Stake out the location of all trenches and lines. Set the elevations of the tank, pipe, and trench bottom.
2. Install sedimentation and erosion control measures. Temporary drainage swales/berms may be installed to protect the site during rainfall events.
3. Excavate and level 18" to 24" wide trenches with proper center-to-center separation. Verify that the trenches are level or have the prescribed slope.

Note: Over excavate the trench width in areas where you are planning to contour.

4. Rake the bottom and sides if smearing has occurred while excavating. Remove any large stones and other debris. Do not use the bucket teeth to rake the trench bottom.

Note: Raking to eliminate smearing is not necessary in sandy soils. In fine textured soils (silts and clays), avoid walking in the trench to prevent compaction and loss of soil structure.

5. Verify that each trench is level using a level, transit, or laser

Preparing the Endcap

1. With a utility knife start the tear-out seal at the appropriate diameter for the inlet pipe. The seal allows for a tight fit for 3-inch, 4-inch SDR35, and 4-inch SCH40 pipe.



1. Start tear-out seal.

2. Pull the tab on the tear-out seal to create an opening in the end cap.

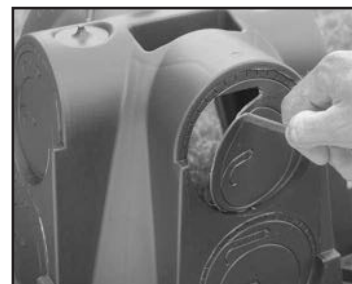

2. Pull tab on tear-out seal.

3. Snap off the molded splash plate located on the bottom front of the end cap.

4. Install splash plate into the appropriate slots below the inlet to prevent trench bottom erosion.

5. Insert the inlet pipe into the end cap at the beginning of the trench. Extend the pipe into the end cap roughly 3 inches before reaching the stop. (Screws optional.)

Installing the System

1. Check the header pipe to be sure it is level or has the prescribed slope.



3. Pull tab on tear-out seal.

2. Set the invert height at 6 or 10 inches as specified in the design from the bottom of the inlet.

Note: Use the Invert Adapter to achieve a 10" invert height.

3. Place the inlet end of the first chamber over the back edge of the end cap. Line up the notches on the bottom of each side of the end cap with the slots on the bottom edge of the chamber.



4. Insert drywall screws.

4. Insert two 1-1/4" drywall screws on each side of the chambers. Tighten each screw until the end cap is firmly secured to the chamber.

5. Lift and place the end of the next chamber onto the previous chamber by holding it at a 45-degree angle. Line up the chamber end between the connector hook and locking pin at the top of the first chamber.



5. Connect the chambers.

Lower the chamber to the ground to connect the chambers.

INSTALLATION INSTRUCTIONS – QUICK4 EQUALIZER 24 CHAMBER SYSTEMS

Note: When the chamber end is placed between the connector hook and locking pin at a 45-degree angle, the pin will be visible from the back side of the chamber.

Note: The connector hook Connect the chambers serves as a guide to ensure proper connection and does not add structural integrity to the chamber joint. Broken hooks will not affect the structure or void the warranty.

6. Swivel the chamber on the pin to achieve the proper direction for the trench layout.

Note: The chamber allows up to a 15-degree swivel in either direction at each joint.

7. Continue connecting the chambers until trench is completed.

Note: As chambers are installed, verify they are level or have the prescribed slope.

8. The last chamber in the trench requires a Quick4 MultiPort Endcap. Lift the end cap at a 45-degree angle and insert the connector hook through the opening on the top of the end cap. Applying firm pressure, lower the end cap to the ground to snap it into place. Do not remove tear-out seal.



8. Attach endcap to chamber.

Note: Use straight lengths of pipe with the Quick4 MultiPort Endcap at the trench ends to create fitting-free looped ends.

9. To ensure structural stability, fill the sidewall area by pulling soil from the sides of the trench with a shovel. Start at the joints where the chambers connect. Continue backfilling the entire sidewall area, making sure the fill covers the louvers.

10. Pack down the fill by walking along the edges of the trench and chambers. This is an important step in assuring structural support.

Note: In wet or clay soils, do not walk in the sidewalls.

11. Proceed to the next trench and begin with Step 1.

Installing Optional Inspection Ports

1. With a hole saw, drill the pre-marked area in the top of the chamber to create a 4-inch opening.

2. Set a cut piece of pipe of the appropriate length into the corresponding chamber's inspection port sleeve.

Note: The sleeve will accommodate up to a 4-inch SCH40 pipe.

3. Use two screws to fasten the pipe to the sleeve around the inspection port.

4. Attach a threaded cap or cleanout assembly onto the protruding pipe at the appropriate height.

5. A small valve cover box may be used if inspection port is below the desired grade.

Covering the System

Before backfilling, the system must be inspected by a health officer or other official as required by state and local codes. Create an as-built drawing at this time for future records.

1. Backfill the trench by pushing fill material over the chambers with a backhoe. It is acceptable to use rock or other clean course material as backfill.

Note: Do not drive over the trenches unless a tracked vehicle is used.

Note: For shallow cover applications, you must mound 12 inches of soil over the system before driving over it, and then grade it back to 6 inches upon completion.

2. It is best to mound several inches of soil over the finish grade to allow for settling. This also ensures that runoff water is diverted away from the system.

3. After the system is covered, the site should be seeded or sodded to prevent erosion.

Note: If the system is for new home construction, it is important to leave marking stakes along the boundary of the system. This will notify contractors of the site location so they will not cross it with equipment or vehicles.

Typical Cover Requirement Based on System Type (Consult your installation permit for the required trench depths.)	
System Type	18" Minimum Trench Depth 6" Minimum Soil Cover
Equal Distribution	18" Minimum Trench Depth 6" Minimum Soil Cover
Capping Fill	16" Minimum Soil Cover for Serial 10" Minimum Soil Cover for Equal
Serial Distribution	24" Minimum Trench Depth 12" Minimum Soil Cover

INSTALLATION INSTRUCTIONS – PRESSURE DISTRIBUTION SYSTEMS

Before You Begin

This section provides septic installation information for Quick4 chambers in pressure distribution systems. These systems can only be installed according to state and/or local regulations. Contact your local regulator for specific requirements. Soil and site conditions must be approved prior to installation. Have your local regulator conduct a thorough site evaluation to determine proper sizing and siting of the system before installation.

These guidelines for construction machinery must be followed during installation:

- Avoid direct contact with chambers when using construction equipment. Chambers require a 12-inch minimum of stabilized cover to support a wheel load rating of 16,000 lbs/axle or equivalent to an AASHTO H-10 load rating.
- Do not drive over trenches. If unavoidable use a tracked vehicle. Never drive down the length of the trenches.
- Onsite rules do not allow for vehicular traffic over drainfields. Compaction may affect performance even if it does not damage the product.

Installing Chambers and Endcaps

1. To allow pressure laterals to drain after each dose, drill a hole in the bottom of the pipe at the end of the pressure line. Place the snap-off splash plate or a paving block at the bottom of the trench to protect the infiltrative surface from erosion.



1. Drill hole in pipe.

2. With a hole saw, drill out the appropriate diameter hole to accommodate the pressure lateral pipe.

3. Insert the pressure lateral pipe into the endcap's drilled opening and slide it into the manifold pipe. Glue the pressure lateral pipe to the manifold pipe.

4. With the pressure lateral pipe through the endcap, place the inlet end of the first chamber over the back edge of the endcap.

Note: Health departments may require a wet-run pressure check be done prior to chamber installation when the pipe is laying on the ground. Check with your local health department for the proper procedure.

5. Secure the pressure lateral pipe to the top of the first chamber with a plastic pipe strap at the outlet end of the unit. Slide the strap up through a slot in the chamber top, down through the other slot, and cinch the two ends around the pipe.



5. Secure pipe to chamber.

Note: The Infiltrator Pipe Support Unit may also be used to

hold and stabilize the pipe. See page 11 for detail.

6. Lift and place the next chamber onto the previous one at a 45-degree angle. Line up the chamber end between the connector hook and locking pin at the top of the first chamber. Lower it to the ground to engage the interlocks.

7. Secure the lateral pipe to the top of the next chamber once in place. Follow the same method in Step 5.

8. Continue interlocking chambers and securing the pipe until the trench is completed.

9. Before attaching the final endcap, remove the tongue of the connector hook on the last chamber with a pair of pliers.



9. Remove tongue.

10. Insert the pressure lateral pipe through the hole in the final endcap and slide the endcap towards the last chamber. Lift the endcap over the modified connector hook and push straight down to secure it to the chamber.



10. Lift endcap.

Note: If cleanout extensions are required, use a hole saw to cut a hole in the endcap at the proper elevation so that the lateral pipe can extend. For clean-out access, a 90-degree sweep elbow that extends to the soil surface can be attached to the lateral pipe.

11. If installing multiple rows of chambers, follow Steps 1-9 to lay the next row of chambers parallel to the first. Keep a minimum separation distance between each row of chambers as required by local code.

INSTALLATION INSTRUCTIONS – CAPPING FILL SYSTEMS

Before You Begin

This section provides septic installation information for Quick4 chambers in capping fill applications. These systems may only be installed according to state and local regulations. If unsure of the installation requirements, contact your state or local regulators. Like conventional systems, the soil and site conditions must be approved prior to installation. Have your local regulator conduct a thorough site evaluation to determine the proper size and location of the system before proceeding with the installation.

Materials and Equipment Needed.

- | | |
|--|---|
| <input type="checkbox"/> Quick4 Chambers | <input type="checkbox"/> Screw Gun |
| <input type="checkbox"/> Quick4 MultiPort Endcaps | <input type="checkbox"/> Shovel and Rake |
| <input type="checkbox"/> Backhoe/Bulldozer | <input type="checkbox"/> Tape Measure |
| <input type="checkbox"/> Hole Saw/Router | <input type="checkbox"/> Cleanout Assembly* |
| <input type="checkbox"/> Bit Laser, Transit, Level | <input type="checkbox"/> 2" Drywall Screws |
| <input type="checkbox"/> Pipe Glue | |
| <input type="checkbox"/> Pipe Hangers/Nylon Straps | *Optional |

These guidelines for construction machinery must be followed during installation:

- The chambers require a 12" minimum of stabilized cover to support an AASHTO H-10 load rating of 16,000 lbs/axle.
- Do not drive over trenches. If unavoidable use a tracked vehicle. Never drive down the length of the trenches.
- Onsite rules do not allow for vehicular traffic over drainfields. Compaction may affect performance even if it does not damage the product.

Preparing the Site

1. From the plans, permit or field conditions, determine the depth of the restrictive layer.
2. Stake out the location of the trenches and set the elevations of the tank, piping, and trench bottom. Install sedimentation and erosion control barriers as necessary.
3. Scarify the disposal area and burrow site to destroy vegetative mat. Be careful not to excavate too deep. Only excavate to the depth specified by the site plans. Excavating too deep may void your septic site approval. Then, verify that elevations per design have been maintained.
4. Be sure to keep a 10-foot minimum separation between the edge of the fill and absorption facility.

Excavating and Placing Fill Material

1. Excavate trenches per design and install chambers per instructions on pages 15 and 16.
2. Fill material shall be applied to the fill site and worked in so that the two contact layers (native soil and fill) are mixed.

Preparing the Endcap

1. With a screwdriver or utility knife start the tear-out seal at the appropriate diameter for the inlet pipe. The seal allows for a tight fit for 3-inch, 4-inch SDR35, and 4-inch SCH40 pipe. (All pipe specs must meet OAR rule 340-073-0060.)



1. Start tear-out seal.



2. Pull tab on tear-out seal.

2. Pull the tab on the tear-out seal to create an opening on the end cap.
3. Snap off the molded splash plate located on the bottom front of the end cap.
4. Install splash plate into the appropriate slots below the inlet to prevent trench bottom erosion.
5. Insert the inlet pipe into the end cap at the beginning of the trench. Extend the pipe into the end cap roughly 4 inches. (Screws optional.)

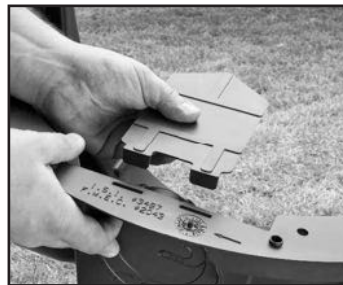

4. Install splash plate.



5. Insert inlet pipe.

INSTALLATION INSTRUCTIONS – CAPPING FILL SYSTEMS

Covering the System

Before backfilling, the system must be inspected by a health or regulatory official as required by state and local codes. Create an as-built drawing of the system at this time, showing the location of the home, tank, d-box and trenches, with dimensions to each.

1. Backfill the trench by pushing the fill material onto the units with a small tracked bulldozer, bobcat, or box blade; maintaining a minimum of six inches of material between the chambers and the tracks.

Note: Only drive tracked vehicles over the fill system when necessary.

2. Evenly grade fill material to a final depth of 10 inches over the chambers for an equal distribution system or 16 inches for a serial distribution system.

3. Leave several inches of soil above the required amount for settling and to divert runoff water from the system.

4. Landscape the absorption facility according to permit conditions and protect from livestock, automotive traffic or other activity that could damage the system.

SHALLOW IN-GROUND DESIGN

SIDE VIEW (not to scale)

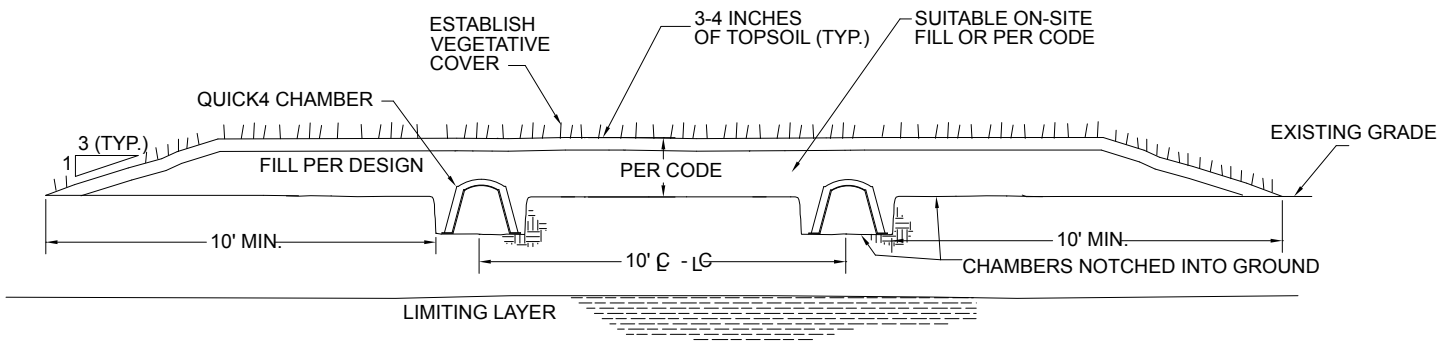

CONVENTIONAL SAND FILTER SYSTEMS USING GRAVELLESS ABSORPTION TRENCHES

Quick4 EQ24 Low Profile (LP) Chambers

The Quick4 Equalizer 24 Low Profile (LP) chamber is designed for shallow placement applications with a minimum soil cover of 4 inches. Chambers installed following a conventional sand filter system must have pressure distribution of effluent.



QUICK4 EQUALIZER 24 LP RULES EXPLANATION

The Quick4 Equalizer 24 LP may be used in lieu of 12" plastic irrigation pipe (PIP), as prescribed in OAR 340-071-0290(6). Trench length and construction shall conform to the requirements described within OAR 340-071-0290(6), with the following modifications:

- a. The trench excavation width shall be between 18" and 24".
- b. The gravelless absorption product shall be 16" wide.
- c. The trench shall be excavated 12" below the natural ground surface.
- d. Backfill shall be mounded such that the final (following settling) backfill thickness meets the 4" minimum soil cover over the chamber.
- e. The gravelless absorption product shall meet the structural requirements identified in IAPMO PS-63.
- f. Each trench shall include a 4" diameter inspection port.

PRODUCT SPECIFICATIONS

Quick4 Equalizer 24 LP Chamber

SIDE AND END VIEWS (not to scale)

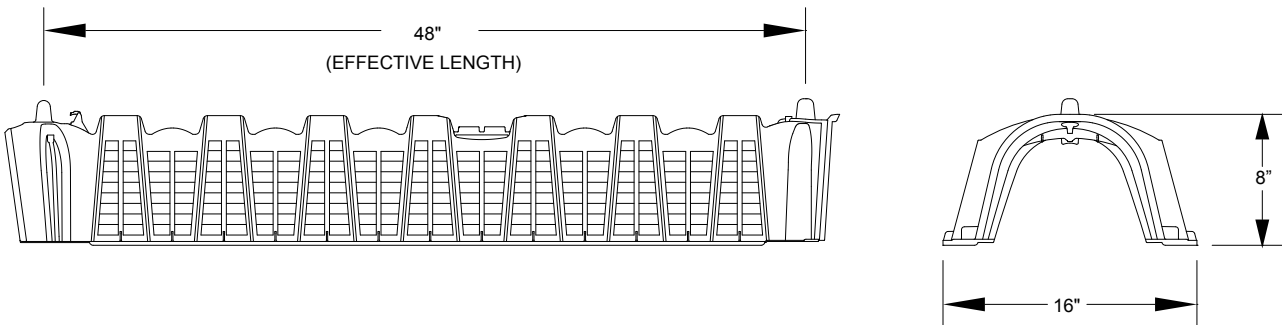

Quick4 Equalizer 24 LP Endcap

END VIEW (not to scale)

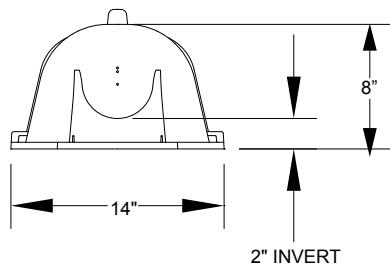

Inlet Adapter (not to scale)

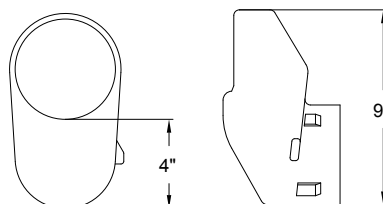

SAND FILTER ABSORPTION SYSTEMS – TRENCH CONFIGURATIONS

Quick4 Equalizer 24 LP Chamber

CROSS SECTION (not to scale)

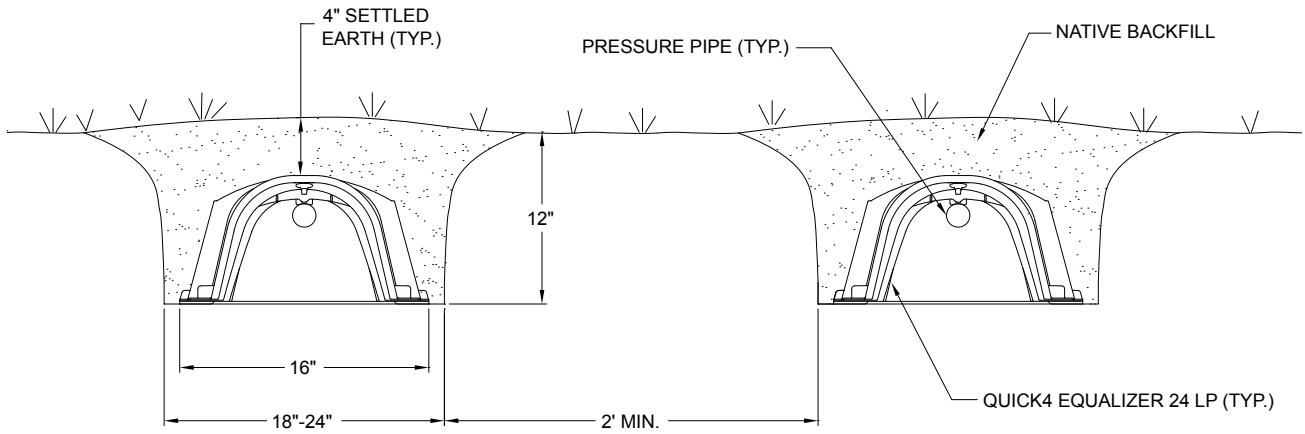

PLAN VIEW (not to scale)

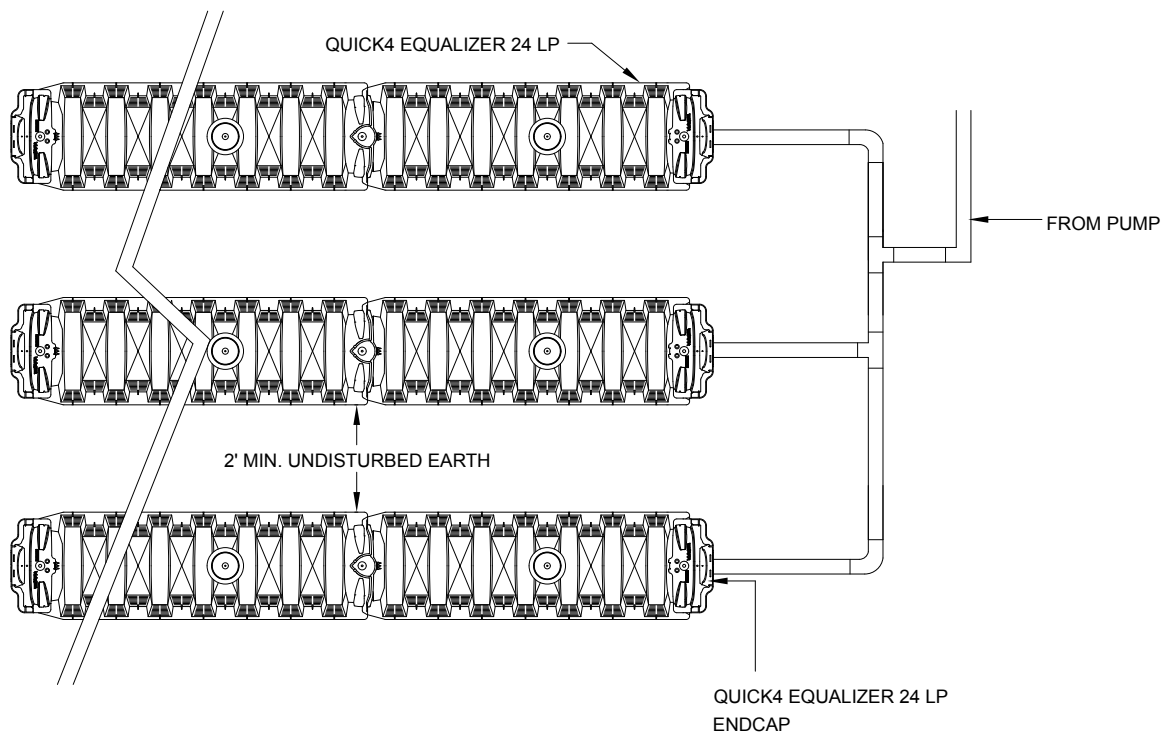

NOTE: Installation for the Quick4 EQ24 LP chamber shall follow the applicable installation instructions beginning on page 15 of this manual. The pressure distribution instructions apply to all gravelless options for use following ATT and sand filter systems in Oregon. Gravity distribution following a conventional sand filter is not permissible.

WARRANTY – TANKS

INFILTRATOR WATER TECHNOLOGIES, LLC (“INFILTRATOR”)

INFILTRATOR® SEPTIC TANK LIMITED WARRANTY FIVE (5) YEAR MATERIALS AND WORKMANSHIP LIMITED WARRANTY

- (a) This limited warranty is extended to the end user of an Infiltrator Tank. A Tank manufactured by Infiltrator, when installed and operated in accordance with Infiltrator’s installation instructions and local regulation by a licensed installer, is warranted to you: (i) against defective materials and workmanship for five (5) years after installation. Infiltrator will, at its option, (i) repair the defective product or (ii) replace the defective materials. Infiltrator’s liability specifically excludes the cost of removal and/or installation of the Tank.
- (b) In order to exercise its warranty rights, you must notify Infiltrator in writing at its corporate headquarters in Old Saybrook, Connecticut within fifteen (15) days of the alleged defect.
- (c) YOUR EXCLUSIVE REMEDY WITH RESPECT TO ANY AND ALL LOSSES OR DAMAGES RESULTING FROM ANY CAUSE WHATSOEVER SHALL BE SPECIFIED IN SUBPARAGRAPH (a) ABOVE. INFILTRATOR SHALL IN NO EVENT BE LIABLE FOR ANY CONSEQUENTIAL OR INCIDENTAL DAMAGES OF ANY KIND, HOWEVER OCCASIONED, WHETHER BY NEGLIGENCE OR OTHERWISE. SOME STATES DO NOT ALLOW THE EXCLUSION OR LIMITATION OF INCIDENTAL OR CONSEQUENTIAL DAMAGES, SO THIS LIMITATION OR EXCLUSION MAY NOT APPLY TO YOU. THIS WARRANTY GIVES YOU SPECIFIC LEGAL RIGHTS AND YOU MAY ALSO HAVE OTHER RIGHTS WHICH VARY FROM STATE TO STATE.
- (d) THIS LIMITED WARRANTY IS THE EXCLUSIVE WARRANTY GIVEN BY INFILTRATOR AND SUPERSEDES ANY PRIOR, CONTRARY, ADDITIONAL, OR SUBSEQUENT REPRESENTATIONS, WHETHER ORAL OR WRITTEN. INFILTRATOR DISCLAIMS AND EXCLUDES TO THE GREATEST EXTENT ALLOWED BY LAW ALL OTHER WARRANTIES, WHETHER EXPRESS OR IMPLIED, OR STATUTORY, INCLUDING ANY WARRANTY OF MERCHANTABILITY, FITNESS FOR A PARTICULAR PURPOSE AND ANY IMPLIED WARRANTIES OTHERWISE ARISING FROM COURSE OF DEALING, COURSE OF PERFORMANCE, OR USAGE OF TRADE. NO PERSON (INCLUDING ANY EMPLOYEE, AGENT, DEALER, OR REPRESENTATIVE) IS AUTHORIZED TO MAKE ANY REPRESENTATION OR WARRANTY CONCERNING THIS PRODUCT, EXCEPT TO REFER YOU TO THIS LIMITED WARRANTY. EXCEPT AS EXPRESSLY SET FORTH HEREIN, THIS WARRANTY IS NOT A WARRANTY OF FUTURE PERFORMANCE, BUT ONLY A WARRANTY TO REPAIR OR REPLACE.
- (e) YOU MAY ASSIGN THIS LIMITED WARRANTY TO A SUBSEQUENT PURCHASER OF YOUR HOME.
- (f) NO REPRESENTATIVE OF INFILTRATOR HAS THE AUTHORITY TO CHANGE THIS LIMITED WARRANTY IN ANY MANNER WHATSOEVER, OR TO EXTEND THIS LIMITED WARRANTY.
- (g) NO WARRANTY OF ANY KIND IS MADE WITH REGARD TO ANY PRODUCT, COMPONENTS, DEVICES, MEDIA OR TREATMENT UNITS WHICH ARE MANUFACTURED BY OTHERS AND ARE INSTALLED IN AN INFILTRATOR TANK. USE OF THESE PRODUCTS ARE AT YOUR OWN RISK.
- (h) THE INFILTRATOR TANK IS DESIGNED TO BE BURIED UNDERGROUND. NO WARRANTY OF ANY KIND IS MADE IF YOUR TANK IS NOT BURIED UNDERGROUND AS SPECIFIED IN THE PRODUCT’S INSTALLATION INSTRUCTIONS.

CONDITIONS AND EXCLUSIONS

There are certain conditions or applications over which Infiltrator has no control. Defects or problems as a result of such conditions or applications are not the responsibility of Infiltrator and are NOT covered under this warranty. They include failure to install the Tank in accordance with instructions or applicable regulatory requirements or guidance, altering the Tank contrary to the installation instructions and disposing of chemicals or other materials contrary to normal tank usage.

The above represents the Standard Limited Warranty offered by Infiltrator. A limited number of states and counties have different warranty requirements. Any purchaser of a Tank should contact Infiltrator’s corporate headquarters in Old Saybrook, Connecticut, prior to such purchase to obtain a copy of the applicable warranty, and should carefully read that warranty prior to the purchase of a Tank.

WARRANTY – DRAINFIELD

INFILTRATOR WATER TECHNOLOGIES, LLC (“INFILTRATOR”) INFILTRATOR WATER TECHNOLOGIES, LLC STANDARD LIMITED DRAINFIELD WARRANTY

(a) The structural integrity of each chamber, endcap and other accessory manufactured by Infiltrator (collectively referred to as “Units”), when installed and operated in a leachfield of an onsite septic system in accordance with Infiltrator’s installation instructions, is warranted to the original purchaser (“Holder”) against defective materials and workmanship for one year from the date upon which a Septic Operation Permit is issued for the septic system containing the Units; provided, however, that if a septic permit is not required for the septic system by applicable law, the one (1) year warranty period will begin upon the date that installation of the septic system commences. In order to exercise its warranty rights, Holder must notify Infiltrator in writing at its corporate headquarters in Old Saybrook, Connecticut within fifteen (15) days of the alleged defect. Infiltrator will supply replacement Units for those Units determined by Infiltrator to be defective and covered by this Limited Warranty. Infiltrator’s liability specifically excludes the cost of removal and/or installation of the Units.

(b) THE LIMITED WARRANTY AND REMEDIES IN SUBPARAGRAPH (a) ARE EXCLUSIVE. THERE ARE NO OTHER WARRANTIES WITH RESPECT TO THE UNITS, INCLUDING NO IMPLIED WARRANTIES OF MERCHANTABILITY OR FITNESS FOR A PARTICULAR PURPOSE.

(c) This Limited Warranty shall be void if any part of the chamber system (chamber, endcap or other accessory) is manufactured by anyone other than Infiltrator. The Limited Warranty does not extend to incidental, consequential, special or indirect damages. Infiltrator shall not be liable for penalties or liquidated damages, including loss of production and profits, labor and materials, overhead costs, or other losses or expenses incurred by the Holder or any third party. Specifically excluded from Limited War-

ranty coverage are damage to the Units due to ordinary wear and tear, alteration, accident, misuse, abuse or neglect of the Units; the Units being subjected to vehicle traffic or other conditions which are not permitted by the installation instructions; failure to maintain the minimum ground covers set forth in the installation instructions; the placement of improper materials into the system containing the Units; failure of the Units or the septic system due to improper siting or improper sizing, excessive water usage, improper grease disposal, or improper operation; or any other event not caused by Infiltrator. This Limited Warranty shall be void if the Holder fails to comply with all of the terms set forth in this Limited Warranty.

Further, in no event shall Infiltrator be responsible for any loss or damage to the Holder, the Units, or any third party resulting from installation or shipment, or from any product liability claims of Holder or any third party. For this Limited Warranty to apply, the Units must be installed in accordance with all site conditions required by state and local codes; all other applicable laws; and Infiltrator’s installation instructions.

(d) No representative of Infiltrator has the authority to change this Limited Warranty in any manner whatsoever, or to extend this Limited Warranty. No warranty applies to any party other than the original Holder.

The above represents the standard Limited Warranty offered by Infiltrator. A limited number of states and counties have different warranty requirements. Any purchaser of Units should contact Infiltrator’s corporate headquarters in Old Saybrook, Connecticut, prior to such purchase, to obtain a copy of the applicable warranty, and should carefully read that warranty prior to the purchase of Units.



INFILTRATOR[®]
water technologies

4 Business Park Road
P.O. Box 768
Old Saybrook, CT 06475
860-577-7000 • Fax 860-577-7001
1-800-221-4436
www.infiltratorwater.com

U.S. Patents: 4,759,661; 5,017,041; 5,156,488; 5,336,017; 5,401,116; 5,401,459; 5,511,903; 5,716,163; 5,588,778; 5,839,844 Canadian Patents: 1,329,959; 2,004,564 Other patents pending. Infiltrator, Equalizer, Quick4, and SideWinder are registered trademarks of Infiltrator Water Technologies. Infiltrator is a registered trademark in France. Infiltrator Water Technologies is a registered trademark in Mexico. Contour, MicroLeaching, PolyTuff, ChamberSpacer, MultiPort, PosiLock, QuickCut, QuickPlay, SnapLock and StraightLock are trademarks of Infiltrator Water Technologies. PolyLok is a trademark of PolyLok, Inc. TUF-TITE is a registered trademark of TUF-TITE, INC. Ultra-Rib is a trademark of IPEX Inc.

© 2016 Infiltrator Water Technologies, LLC. All rights reserved. Printed in U.S.A.

C11 1215IWT

Contact Infiltrator Water Technologies' Technical Services Department for assistance at 1-800-221-4436