



TPO MEMBRANE INSTALLATION HANDBOOK



Tool and Supply Checklist
Step-by-Step Instructions
Photo Illustrations
Detail Drawings
Product List

CONTENTS

PAGE

3	Equipment Listing
4	Perimeter Sheet Requirements
6	Plate and Fastener Spacing Requirements
7	Substrate Preparation
10	Mechanically Attached Membrane Placement & Securement
12	Flashing
27	Hot Air Welding Guidelines
35	Roof Repair Guide
38	Flex RhinoBond™ Attachment System
40	Detail Drawings
66	Product List

ABOUT FLEX ROOFING SYSTEMS

Flex manufactures Elvaloy® KEE-, PVC- and TPO-based materials for the commercial roofing industry. Our product research, quality control and service are on the leading edge of single ply roofing technology.

Flex serves you with a highly experienced national sales force, backed by technical expertise resources at our Leesport, PA facility.

Flex Roofing Systems meet or exceed all national roofing standards, such as The American Society for Testing and Materials, Factory Mutual Wind Uplift and Underwriters Laboratories Class A Fire Resistance. Flex Roofing Systems may also contribute to LEED credits.

We manufacture Flex products using technology that locks in excellent product flexibility, as well as superior chemical and weather resistance. Our processes use proprietary extrusion methods assuring consistent product quality. Our unique CAD roof design assistance program is geared specifically for roof construction and single ply installations for new or retrofit applications.

Flex assures the specifier, owner and the contractor that the highest quality roofing will be supplied, backed by pre-installation reviews, on-site inspections and subsequent guarantees.



2670 Leisch's Bridge Road, Suite 400
Leesport, PA 19533
610-916-9500 • 1-800-969-0108
FlexRoofingSystems.com

EQUIPMENT AND ACCESSORIES LISTING

- Clean, asphalt-free extension cord sufficient to handle power requirements
- One (1) pair of scissors per man
- Tape measures, varying up to 100 feet in length
- Chalk boxes, chalk
- Four inch (4") wide paint brushes
- Clean cotton rags
- Caulking guns
- Push brooms
- Non-permanent ink or crayon writing element for marking seams
- Several Flex Seam Probes for probing of seams
- Clean, asphalt free waterproof canvas or tarp for covering of materials
- Several one & one-half inch (1 1/2") wide silicon hand rollers
- Several standard screw guns w/ disengaging clutch (1800-2500 RPM's)
- One-half inch (1/2") nap paint rollers w/ solvent resistant cores and handles
- Hammers, screwdrivers, sockets, allen wrenches and drill bits
- Utility knife, hook blades, straight blades
- Approved fasteners and plates
- Approved cleaners or solvents
- Approved caulking or sealant
- Wire brushes for cleaning welder tips
- Assortment of tips or nozzles for hand held hot air welder
- Hammer drill or Tapcon Anchor drive

Hot Air Welding Equipment

- 1) BAK or Leister Varimat automatic hot air welding machine, requires 230 volt, 4600 watt power.
- 2) BAK or Leister Triac hand held hot air welder, requires 120 volt, 1600-watt power
- 3) Portable Electric Generator: minimum output of 9500 watts to adequately provide power to operate one automatic hot air welder and one hand held hot air welder.

FLEX TPO PLUS MECHANICALLY ATTACHED ROOF SYSTEMS

PERIMETER SHEET REQUIREMENTS AND FASTENER GUIDE

Perimeter Sheets

Flex TPO mechanically attached roof systems require the installation of ½ (half) sheets (a sheet 4' or 5' wide) along the roof perimeter. The roof perimeter is defined as the edges of each roof section. In situations that involve multi-level roof areas that meet at a common wall, the adjacent edge of the upper roof is treated as a roof perimeter if the height difference is greater than 3 (three) feet. A perimeter sheet is not required at the base of the wall.

The height of the building and the wind uplift pressure requirements of the project are factored to determine the number of perimeter sheets to install. A minimum of one perimeter sheet is required.

Sloped roof assemblies equal to or greater than a 2/12 slope require a minimum of one perimeter sheet to be installed centered over the roof ridge.

Buildings that have canopies or overhangs or large openings in the walls require the additional installation of perimeter sheets in these areas. Contact Flex Technical Services for assistance in determining the number of perimeter sheets to install in these roof areas. 1-800-969-0108.

The following chart is provided to act as a general guide to assist in calculating the perimeter sheets required for most installations. The project specifications, Building Code requirements or Factory Mutual approval may dictate fastener/plate placement options and the installation of additional rows of perimeter sheets with enhanced membrane securement.

Wind Velocity	Building Height	Number of Perimeter Sheets Required
≤ 100 mph	≤ 50' 50' to 75'	1 or 2 * 2
100 to 129 mph	≤ 75'	2 **
≥ 130 mph	≤ 75'	4

* See important notes on Page 5

Notes:

- 1) Fastener assembly spacing for perimeter sheets is the same as required for the fastener spacing of the roof field area sheets.

*Installation of 12' wide membrane requires 2 rows of perimeter sheets fastened 12" o.c.

**Gypsum or Cementitious Wood Fiber Decks in the 100 to 129 mph wind zone require installing 3 rows of perimeter sheets.

Notes:

- 1) When Lightweight Insulating Concrete Decks are installed over a Steel Deck, the fasteners must penetrate through the Lightweight Insulating Concrete Deck, and must attach to the Steel Deck.
- 2) Cementitious Wood Fiber, Gypsum, and Wood Decks are not acceptable for a mechanically attached roof system installation in the ≥ 130 mph wind zone.

* XHD Flex Plates and Fasteners 6" o.c. SXHD Flex Plates and Fasteners 12" o.c.

GUIDE TO FLEX FASTENER AND FLEX PLATE PLACEMENTS

This guide is based on current FM Approvals for the field sheet securement criteria.

Steel Deck or Structural Concrete

Membrane Type	Row Spacing	Fastener Type	Fastener Spacing	Uplift Rating (psf)
TPO Plus	42.5"	XHD	12"	105
TPO Plus	42.5"	XHD	6"	165
TPO Plus	91"	SXHD	12"	90
TPO Plus	91"	XHD	6"	105
TPO Plus	91"	XHD	12"	60
TPO Plus	115"	XHD	12"	75
TPO Plus	115"	SXHD	12"	90
TPO Plus	115"	XHD	6"	105
TPO Plus	115"	XHD	6"	120
TPO Plus	115"	XHD	12"	60
TPO Plus	138.5"	SXHD	6"	120

Acceptable steel decks must meet the following minimum requirements:

Must be 18, 20, or 22 gauge thickness, 1.5" deep.

Deck installation is to be in accordance with Factory Mutual requirements.

Structural Concrete decks require the use of Flex CD-10 or Flex HD 10-14 fasteners with the appropriate Flex seam plate.

FLEX TPO PLUS MECHANICALLY ATTACHED ROOF MEMBRANE

INSTALLATION GUIDE

This guide is intended to be a point of reference in assisting the Flex Authorized Applicator. The installer should always refer to the project specifications for details and application requirements for each unique roof system installation.



Loading the roof. Follow all OSHA procedures for safety.

SUBSTRATE PREPARATION

Defects in the substrate surface must be reported and documented to the Building Owner's Representative for assessment. The roofing contractor shall not proceed with the roof system installation until the defects in the substrate have been corrected.

Recover or Retrofit Roofing Applications: The project specifier shall identify damaged or wet insulation areas. The insulation as indicated shall be cut out and removed from the roof area. The removed insulation shall be replaced with new insulation of the proper size to fill the space (flush with existing surface $\pm 1/4"$) and obtain a relatively smooth surface acceptable for the installation of the new roof system.

Existing Single Ply Roof Membranes: If the existing membrane is to be left in place it must be cut into sections no larger than 100 square feet per each section. All flashing must be removed at the perimeter edge, roof drains and roof penetrations.

Gravel-Surfaced Built Up Roofing: The loose gravel must be removed either by vacuuming or power brooming. The surface must be leveled to prevent the insulation or recover board from bridging.

All Projects: The substrate must be smooth and relatively even without high spots or depressions. Any accumulated water, ice, or snow must be removed to prevent the absorption of moisture in the new roofing components and roofing system. The substrate shall be clean and free from debris and any other foreign material.



Placing Flex fan-fold GreenGuard re-cover board

Vapor or Air Barrier Installation

Install the barrier in accordance with the manufacturer’s written instructions and the project specifications for the installation of the specified product.

Wood Blocking

Install wood blocking as indicated by the project specifications and in accordance with current Flex Details and Specifications. Blocking is always required at roof edges and roof penetrations. The wood blocking

is installed so the top of wood is flush with the top surface of the roof insulation or recover board. The wood blocking width is to exceed the width of flange to be attached to the blocking. The securement of the blocking shall be in a manner to meet or exceed the local building code requirements and the wind uplift pressure resistance required in the project specifications.

Flex Insulation/Recover Board

Only install as much insulation or recover board as can be covered with roofing membrane and be made watertight in the same day. Flex Insulation/recover boards are to be installed butted together with no gaps larger than ¼" in the joints acceptable. Gaps in the joints larger than ¼" must be filled. Top surfaces of the insulation/recover boards are to be aligned and flush with each other. Differences in the top edge alignment greater than 1/8" are not acceptable.

Flex Insulation/recover board that is to be installed in multiple layers must have the joints staggered between each layer. Flex Insulation/recover board is mechanically attached to the roof deck with Flex Fasteners and Flex Insulation Plates.



Mechanically fastened Flex insulation board

Restrictions

Adhesives and sealants must be protected when ambient temperatures are lower than 40° F. Insulated, heated storage boxes must be provided to store the products on the roof for temporary storage. Insulation and underlayment must be stored in a manner to keep the products dry and protected from the elements. The products must be stored off the roof surface on skids and covered with a breathable watertight cover.

MECHANICALLY ATTACHED MEMBRANE PLACEMENT AND SECUREMENT

The substrate must be clean and dry prior to installing the Flex Roof Membrane. The type of Flex fastener is dependent upon the deck type. The specific type of approved fastener is found in the components section of Flex's Technical Manual if the proper fastener cannot be determined contact the Flex Technical Service Department.

1-800-969-0108

Perimeter Sheet Attachment

The number of perimeter sheets, the fastening placement density, and the field membrane securement is dependent on the wind uplift pressure resistance required by the project specifications and physical location. Contact the Flex Technical Service Department for assistance if required.

Field Membrane Securement

The field membrane sheets are positioned so that adjoining field membrane sheets overlap 5-1/2" to 6" at those locations where fasteners and plates are located, typically along the length of the membrane. The end roll sections are also mechanically fastened and overlapped 5-1/2" to 6" to cover the fastener and plate and provide for an adequate hot air weld.

The membrane is secured at the approved fastener density with the appropriate type of fastener approved for the deck and the wind uplift pressure resistance. Unroll and position the sheet. Install a fastener and plate in one end of the sheet on the appropriate fastener mark. Go to the opposite end of the sheet and pull sheet into position along the lay line and install a fastener and plate at the appropriate mark.

Place the remaining fasteners and plates. Hot air weld the seam and continue in sequence installing the remainder of the sheets across the roof area. Additional securement must be provided at the perimeter of each roof level, roof section, expansion joint or roof divider, all roof penetrations and curbs, adjacent walls and at any angle change where the slope exceeds 2/12.

All seams must be completed by hot air welding the same day they are installed. Thoroughly probe the seams with a seam probe and repair any voids or defects discovered.



Mechanically fastened Flex TPO membrane



Flex fasteners and screws help make installation easier and faster.

FLASHING

General Flashing Conditions

Flex Reinforced Flashing Membrane is to be installed for the flashing of parapet walls, roof equipment curbs, expansion joints and roof dividers, and for most other roof detail flashing areas.

Flex non-reinforced flashing membrane may be used for those areas where the use of pre-formed accessories cannot be installed such as certain pipe penetrations, corners, and scuppers details.

Re-roofing Flashing Conditions

Existing flashings must be removed prior to installing the new Flex Flashing Membrane. Termination Bar, surface mounted reglet, or surface mounted counter flashings must be installed directly to the wall surface.

Application

Adhere the flashing membrane to walls, curbs and other vertical surfaces with Flex Flashing Adhesive. The Flashing Adhesive is applied to both the membrane and the surface to which it is bonded. The coverage rate is dependent on the type of substrate but should average approximately 60 square feet per gallon for both the membrane and the substrate. The flashing adhesive is allowed to dry until it is tacky and the flashing membrane is rolled into the adhesive.

Complete all seams of the flashing membrane by the hot air welding method.



Applying flashing adhesive



Hanging the wall flashing



Rolling wall flashing into place



Flashing on an open top curb



Flashing existing mechanical unit



Hand welding a field-fabricated flashing



Hand welding a pre-formed outside corner flashing



Pre-formed inside corner flashing



Wall flashing with Flex Lip-T bar, with approved caulking



Wall flashing with metal counter-flashing

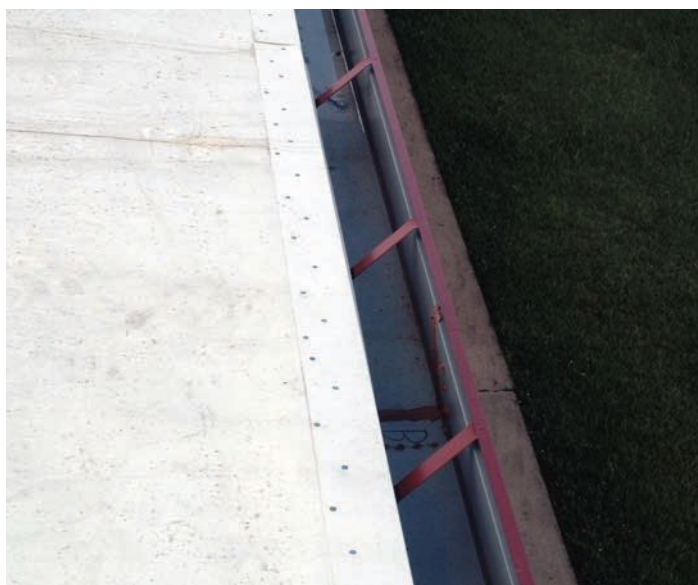

FlexClad™ metal drip edge, properly secured



Flex Trim Strip welded to FlexClad™ metal and field membrane



Applying water block to a drain flange under the field membrane



Installing a Flex TPO Flashing target sheet over the field sheet drain opening



Tightening the clamping ring on a drain flashing



Welding a Flex pre-formed pipe boot to the field membrane



Clamp and caulking is required at the top of the pipe boot



Field-fabricated method with Flex TPO Flashing Membrane



Flex Split Pipe Boot, a pre-fabricated flashing



Post support flashing, available pre-formed from Flex



FlexClad™ metal pitch pan, fabricated by the contractor



Pitch pan topped off with Flex Pourable Sealer



Pitch pans solve difficult flashing details



Through-wall scupper made of FlexClad™ Metal



Expansion joint cover, with Flex TPO Reinforced Flashing Membrane

ACCESSORIES

Walkway Pads

Install walkway pads in those locations as designated in the specifications. Thoroughly clean and prepare the area of the roof membrane that is to be hot air welded to the walkway pad.

The Flex Walkway Pad is installed in maximum lengths of 10'. Position sections of the walkway pad to leave a space between adjacent sheets approximately 2" wide. Do not cover field seams with the Walkway Pad. Position the pads to leave minimum 4" wide area exposed at the field seams. Hot air weld all four sides of the walkway pad to the field membrane.



Flex Walkway Pad

Pavers

Either a protection sheet of Flex TPO Flashing Membrane or Flex 180N Geotextile Separation Layer must be installed under all concrete paver blocks.



Pavers installed over properly flashed drain detail

Night Seal

The new roof membrane must be sealed at the end of each work day to prevent water infiltration. The membrane may be temporarily sealed by securing the down slope edge with roof cement, hot asphalt, spray urethane foam or similar water blocking materials. Embed the membrane into the sealant product and insure continuous contact. The following day when the installation is resumed cut away and discard the membrane where the night seal was applied before continuing with installing the adjoining section.



HOT AIR WELDING GUIDELINES

Hot Air Welding Equipment

A. The Flex Automatic Welding Machine is an electrically powered, self propelled device that utilizes an electric heating element and forced air to weld the seams in Flex Thermoplastic Single Ply Membranes.



Flex Automatic Hot Air Welding Machine

B. Hand Held Welder is an electrically powered hand held device that utilizes an electric heating element and forced air to weld the seams in Flex Thermoplastic Single Ply Membranes.



BAK™ Hand-Held Hot Air Welding Tool

C. The Flex Pressure Roller is a silicon hand roller used for rolling the hot air welded seams.



Silicon hand roller

D. Seam probe is a hand held instrument used for probing the hot air welded seams to insure the integrity of the welds.



Seam probe

E. When using a portable generator for providing electrical power to the automatic or hand held welders, a 9500 watt minimum output generator is recommended to run one automatic and one held welder.



Minimum 9500 watt generator recommended for one hand held and one automatic hot air welder

Welding Preparation

The surfaces to be welded must be clean and dry. Check the membrane overlaps to determine whether they have been contaminated with field dirt. If the seam is contaminated, thoroughly clean the membrane with the recommended cleaner. It is required that all installed membrane seams be hot air welded the same day the membrane is installed.

Automatic Hot Air Welder Operation

Consult the welding machine manufacturer's recommendations for proper temperature setting and speed control of the equipment. The temperature setting and speed setting vary with ambient temperature, type of substrate and membrane thickness.

A test weld must be performed at the start of each welding session to determine the proper settings for the machine. As a general guide for automatic hot air welding the suggested starting setting is 1000°F at 12' per minute. Set up the welder and allow it to run for 5 to 10 minutes to warm up.

Position the welding unit with the guide handle pointing the same direction the machine will move along the seam. Lift the overlapping membrane and insert the blower nozzle between the 2 sheets of membrane.

Immediately engage the machine drive to start the machine moving and prevent over heating or burning the membrane. Guide the machine along the length of the seam keeping the small guide wheel aligned with edge of the top membrane sheet.

When the machine reaches the end of its run remove the blower nozzle from between the overlapped membrane and stop the drive mechanism. The portion of the seam at the beginning and end of the run that could not be welded with the automatic welder must be completed with the hand welder.

Test welds should be performed at the start of each welding session. Weld 2 sample pieces of the membrane together. Allow the membrane to cool to ambient temperature.

Cut a test sample across the width of the seam at least 1" wide and longer than the width of the seam.

Pull the welded seam sample apart and examine the width of the delamination from the reinforcing fabric. The width of the weld should be no less than 1.5" indicating a proper hot air welded seam.



Automatic hot air welder allows workers to operate upright, which is more comfortable and much faster.

Hand Welder Operation

The hand welder is generally utilized for flashing details and field seams less than 10' in length. Consult the welding machine manufacturer's recommendations for proper temperature setting for the equipment. The temperature setting will vary with ambient temperature, type of substrate and membrane thickness.

As a general guide for welding the Flex TPO Plus Membrane the Leister Triac Hand Welder suggested starting setting is # 6. Start the Flex Leister welder and allow it to run for a few minutes to warm up.

Insert the nozzle of the welder between the 2 sheets of membrane holding the welder in one hand and the silicon roller in the opposite hand.

Slide the welder along the seam while simultaneously applying pressure rolling with hand welder to the outside edge of the seam.

The roller must be placed flat against the membrane to be welded. Do not turn the roller on edge when welding the membrane.



Hot air welding with a hand held tool



Using a hand held hot air welder to install wall flashing

Seam Probing

All welded seams must be probed with the Flex Seam Probe to determine the quality and integrity of the weld. Allow the hot air welded seam to cool to ambient temperature before beginning the probing process.

Apply pressure and pull the point of the seam probe along the edge of the seam. The tool will not penetrate the edge of a properly welded seam. Repair any voids discovered by cleaning and re-welding the seam. After the repair cools, probe the area to confirm the proper weld.



All welded seams must be probed to test for secure welds

Defects and Repairs

Voids are repaired by cleaning the two sections of membrane and inserting the nozzle of the hand welder into the void. Apply pressure with the silicon roller and roll the top surface towards the outer edge to cause the membrane to fuse together wrinkles in the seam, burn marks or overheated areas, and any area where adhesive contaminated the seam must have a patch installed over the defective area.

When installing a patch the area to receive the patch must be thoroughly cleaned. The patch is to be made from the reinforced plain backed membrane. The patch should be sized to extend past all edges of the defective area a minimum of 2" with all corners rounded. The patch is hot air welded to the existing membrane.

ROOF REPAIR GUIDE

Temporary or Emergency Repair

In the event that the Flex Roofing System becomes damaged the building owner may be required to make temporary repairs to the roof system, which will not affect the warranty coverage.

Materials

Flex one component gun grade moisture curing polyurethane sealant. Flex Thermoplastic Reinforced TPO Plus® 45 mil, 60 mil, or 80 mil Flashing Membrane. A detergent cleaner such as Flex orange power cleaner or trisodium phosphate is applied to remove residual dirt. Final cleaning is achieved with a solvent cleaner such as Flex Weathered Membrane Cleaner™, Scotch Brite Pads®, or clean white cotton rags.

Procedure

Locate the damaged area. Prepare the surface by removing debris, contaminants and ballast from the area of the membrane or flashing to be repaired. The area should extend beyond the perimeter of the patch to provide an ample-sized clean work area. Scrub the repair area clean with an approved cleaner.

Dry the repair area with a rubber squeegee and clean, absorbent, lint-free cloths. Cut a patch from a piece of Flex TPO Flashing Membrane. The patch should extend past any part of the damaged area by a minimum of 4." Round off the corners of the patch. Wipe the area of the existing membrane to receive the patch and the underside of the patch material with a clean, absorbent, lint-free cloth dampened with a solvent such as Flex Weathered Membrane Cleaner. Do not pour the solvent directly on the membrane. Wipe the repair area clean and allow the area to air dry. Fill the damaged area with Flex gun grade sealant. Apply Flex gun grade sealant to the back of the Flex TPO Flashing Membrane patch. Press the Flex patch into place over the damaged area and roll firmly with the rubber faced hand roller. Caulk the outside edges of the patch with a bead of the Flex sealant.

Note: This procedure is considered a temporary repair. A permanent hot air welded patch can be installed at a later date, by an approved applicator, directly over the existing temporary patch.

Permanent Repair

Flex requires that this repair be performed by a Flex Approved Applicator. This repair is required to be completed in accordance with current Flex Details and Specifications.

Materials

Flex Thermoplastic Reinforced TPO Plus® 45 mil, 60 mil, or 80 mil Flashing Membrane. A detergent cleaner such as Flex orange power cleaner or trisodium phosphate is applied to remove residual dirt. Final cleaning is achieved with a solvent cleaner such as Flex Weathered Membrane Cleaner, Scotch Brite Pads, clean white cotton rags.

Procedure To Repair Holes or Tears

Locate the damaged area. Prepare the surface by removing debris, contaminants and ballast from the area of the membrane or flashing to be repaired. The area should extend beyond the perimeter of the patch to provide an ample-sized clean work area. Dampen a Scotch Brite Pad and scrub the repair area clean with an approved cleaner to loosen and remove heavy residual dirt. Dampen a clean white cotton rag and clean the repair area with an approved cleaner a second time.

Dry the repair area with a rubber squeegee and clean, white, cotton cloths. Cut a patch from a piece of Flex TPO 45 mil flashing membrane. The patch should extend past any part of the damaged area by a minimum of 4." Round off the corners of the patch. Wipe the area of the existing membrane to receive the patch and the underside of the patch material with a clean, absorbent, lint-free cloth dampened with a solvent such as Flex Weathered Membrane Cleaner. Do not pour the solvent directly on the membrane.

Wipe the repair area clean and allow the area to air dry. Lay the patch over the area and tack weld to the existing membrane with the hand held hot air welder and rubber faced hand roller. Pre-weld the patch by inserting the hot air nozzle under the patch and forming a continuous pre-weld approximately 2 inches from the outer edge of the patch. Finish weld the outer 2 inches of the patch pressing firmly with the rubber faced hand roller. In the case of mechanically fastened or loose laid systems it is often possible to weld the patch to the underside of the existing membrane. Allow the welded area to cool to ambient temperature and check the welded edge for voids using a seam probe. If voids are found re-weld with the hot air welder, and recheck with the seam probe.

Procedure to Repair Voids in Hot Air Welded Seams

Prepare the surface by removing debris, contaminants and ballast from the area of the membrane or flashing to be repaired. The area should extend beyond the perimeter of the void to provide an ample-sized clean work area. Check all hot air welded seams for voids with a Flex seam probe. When a void is found open the seam until a fully welded seam area is determined. Scrub the repair area clean with an approved cleaner being sure to clean both the upper and lower surfaces of the seam.

Dry the repair area with a rubber squeegee and clean, absorbent, lint –free cloths. Wipe the area of the bottom membrane and the underside of the upper selvedge edge membrane with a clean, absorbent, lint-free cloth dampened with a solvent such as Flex Weathered Membrane Cleaner. Do not pour the solvent directly on the membrane. Wipe the repair area clean and allow the area to air dry.

Pre-weld the seam by inserting the hot air nozzle into the seam and forming a continuous pre-weld approximately 2 inches from the outer edge of the selvedge edge. Finish weld the outer 2 inches of the seam pressing firmly with the rubber faced hand roller. Allow the welded area to cool to ambient temperature and check the welded seam for voids using a seam probe. If voids are found, re-weld with the hot air welder and recheck with the seam probe.

Record the Repair

Flex’s warranty requires that all leaks be reported to Flex in writing within 30 days of the occurrence. Flex will authorize an Approved Applicator to perform repairs covered under the terms and conditions of the roof warranty.

The Building Owner is responsible for reasonable roof maintenance and any repairs that are not covered under the terms and conditions of the roof warranty. Flex’s warranty requires that all repairs be reported to Flex in writing. The information required will be the number of and location of the repaired areas. The cause of the leak must also be reported. (e.g. Damage by others, protruding fastener, cold weld)

Flex RhinoBond™ System - An Optional Installation Technique

As an alternative to manual mechanically attached systems, the Flex RhinoBond™ System allows faster and more secure installation of single ply thermoplastic membranes.

KEY ADVANTAGES

- Fewer seams, no half sheets
- Fewer fasteners, faster dry-in
- Fasteners do not penetrate the membrane
- Portable induction technology welds membrane to Flex RhinoBond™ Insulation Plates (standard plates will not work)
- Two operators can weld up to 32 squares per hour
- Even roof load distribution; FM approved up to 120 psf
- Increased production results in lower installed cost





- *Flex RhinoBond Insulation Plates™ are installed beneath the membrane.*
- *The Flex RhinoBond Tool™ heats the plate, welding it to the membrane.*
- *The magnet holds the membrane to the plate to complete the weld.*
- *The Flex RhinoBond Tool™ welds the RhinoBond Plate™ and Flex Roof Membrane™ in approximately 5 to 7 seconds.*



How Does It Work?

The Flex RhinoBond Tool™ creates heat by induction, heating the specially treated Flex RhinoBond Plate™ that attaches the insulation to the roof deck. The heat welds the thermoplastic membrane securely to the Flex RhinoBond Insulation Plate.™

For more information on the high-production Flex RhinoBond™ System, please call **1-800-969-0108** or visit **www.FlexRoofingSystems.com**

DETAIL INDEX

Drawing Content	Page	Flex Ref #
TPO Insulation Attachment	41	1.04
Membrane Sheet Layout	42	2.01
Lap Cross Section	43	2.03
Plate & Fastener Placement	44	2.05
60 Mil & 80 Mil T-Joint	45	2.06
Ridge Membrane Attachment	46	2.07
Low Profile Expansion Joint	47	3.01
Expansion Joint Wall	48	3.02
Curb Flashing	49	3.03
Coated Metal Curb Flashing	50	3.04
Parapet Flashing	51	3.06
Flashing Terminations	52	3.08
Roof Drain	53	4.01
Roof Drain II	54	4.02
Pre-Molded Pipe Flashing	55	4.03
Field Fabricated Pipe Flashing	56	4.04
Hot Pipe Flashing	57	4.05
Flex TPO Split Pipe Boot	58	4.06
Inside Corner Flashing	59	5.01
Pre-Molded Outside Corner	60	5.02
Flex TPO Pitch Pocket	61	5.04
Through Wall Scupper	62	5.05
Shingle Tie In	63	5.06
Shingle Tie In	64	5.07
Siding Termination	65	5.08

DETAILS

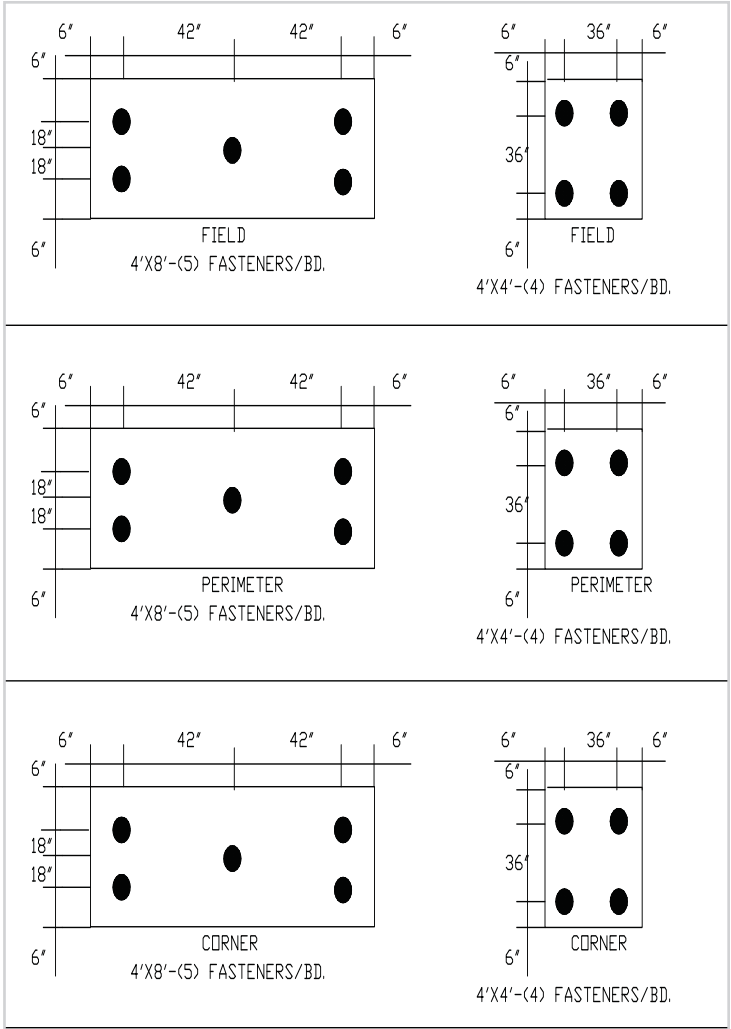

NOTES:

- 1) MINIMUM THICKNESS OF INSULATION SHALL BE 1.3"
- 2) SEE FACTORY MUTUAL APPROVAL GUIDE FOR APPROVED FASTENERS/PLATES.
- 3) FASTENING PATTERN FOR ASSEMBLIES THAT DO NOT INCORPORATE AIR OR VAPOR RETARDERS.
- 4) FM 1-90 FASTENING PATTERN

TITLE		TPO INSULATION ATTACHMENT	
NAME		DETAIL NO. 1.04	
DRAWN BY:	KF	DATE:	11/2008
APPLICABLE TO ALL FLEX TPO			
MECHANICALLY FASTENED SYSTEMS			
FLEX MEMBRANE INTERNATIONAL		LEESPORT, PA 19533 800-969-0108 FlexRoofingSystems.com	

MINIMUM OF ONE 4' (1200mm),
5' (1500mm), OR 6' (1800mm)
WIDE PERIMETER SHEET
(NOTES 1 & 2)

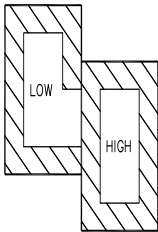
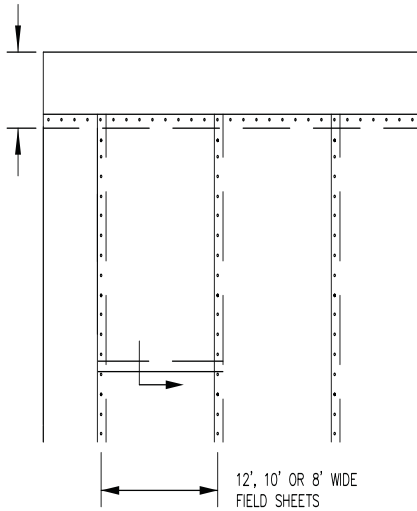

PERIMETER
AREA

ROOF HEIGHT
DIFFERENTIAL
GREATER THAN 3'

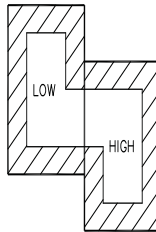

PERIMETER
AREA

ROOF HEIGHT
DIFFERENTIAL
LESS THAN 3'

NOTES:

1. WHEN USING 10' (3000 mm) or 12' (3700 mm) WIDE FIELD SHEETS, 5' (1500mm) or 6' (1800 mm) WIDE PERIMETER SHEETS ARE UTILIZED. WHEN USING 8' (2400 mm) WIDE FIELD SHEETS, 4' (1200 mm) WIDE PERIMETER SHEETS ARE USED.
2. REFER TO MANUFACTURES APPROVALS FOR MEMBRANE FASTENING CRITERIA FOR REQUIRED NUMBER OF PERIMETER SHEETS AND MEMBRANE FASTENING.
3. SECUREMENT NOT REQUIRED AT END ROLL SECTIONS; OVERLAP MEMBRANE 2" TO 3" (50 mm TO 75 mm).
4. FOR INSULATION SECUREMENT, REFER TO FLEX MF/R 1.
5. IF A FACTORY MUTUAL RATING IS REQUIRED, MEMBRANE FASTENING AT CORNERS MUST EXTEND TO ROOF EDGES IN BOTH DIRECTIONS.

TITLE	
TPD MEMBRANE SHEET LAYOUT	
NAME	
DETAIL NO. 2.01	
DRAWN BY:	DATE:
KF	11/2008
APPLICABLE TO ALL FLEX TPD	
MECHANICALLY FASTENED SYSTEMS	
FLEX	
MEMBRANE	LEESPORT, PA 19533
INTERNATIONAL	800-969-0108
	FlexRoofingSystems.com

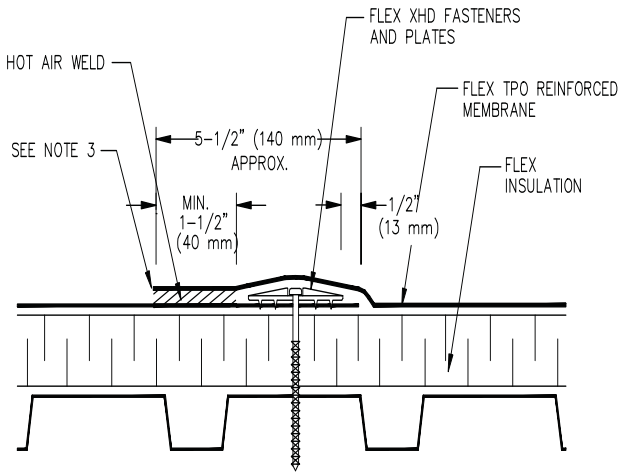

NOTES:

REFER TO MANUFACTURES APPROVALS FOR MEMBRANE FASTENING CRITERIA, MEMBRANE FASTENING CRITERIA" FOR PROPER FASTENERS, PLATES AND FASTENING DENSITY. IF A FACTORY MUTUAL RATING IS REQUIRED, REFER TO FLEX FM APPROVAL GUIDE.

1. POSITION SEAM FASTENING PLATES BEYOND NON-REINFORCED ENCAPSULATED EDGE.
2. APPROXIMATELY 1/8" (3 mm) DIAMETER BEAD OF CUT-EDGE SEALANT IS REQUIRED ON CUT EDGES OF FLEX TPO REINFORCED MEMBRANE.

TITLE	
LAP CROSS SECTION	
NAME	
DETAIL NO. 2.03	
DRAWN BY:	DATE:
KF	11/2008
APPLICABLE TO ALL FLEX TPO	
MECHANICALLY FASTENED SYSTEMS	
FLEX MEMBRANE INTERNATIONAL	LEESPORT, PA 19533 800-969-0108 FlexRoofingSystems.com

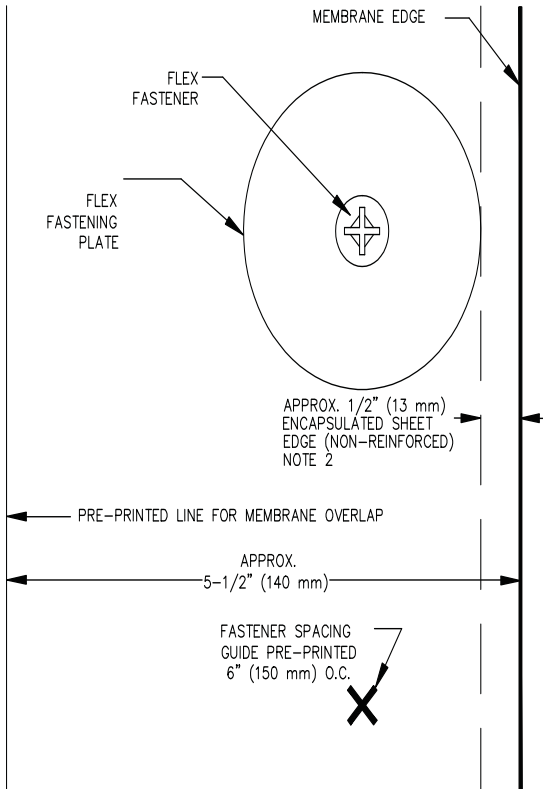

NOTE:

1. FLEX TPO XHD PLATE AND FASTENER OR FLEX TPO SXHD PLATE AND FASTENER ARE REQUIRED OVER STEEL AND WOOD DECKS.
2. POSITION SEAM FASTENING PLATES BEYOND NON-REINFORCED ENCAPSULATED EDGE.

TITLE	
PLATE & FASTENER PLACEMENT	
NAME	
DETAIL NO. 2.05	
DRAWN BY:	DATE:
KF	11/2008
APPLICABLE TO ALL FLEX TPO	
MECHANICALLY FASTENED SYSTEMS	
FLEX MEMBRANE INTERNATIONAL	LEESPORT, PA 19533 800-969-0108 FlexRoofingSystems.com

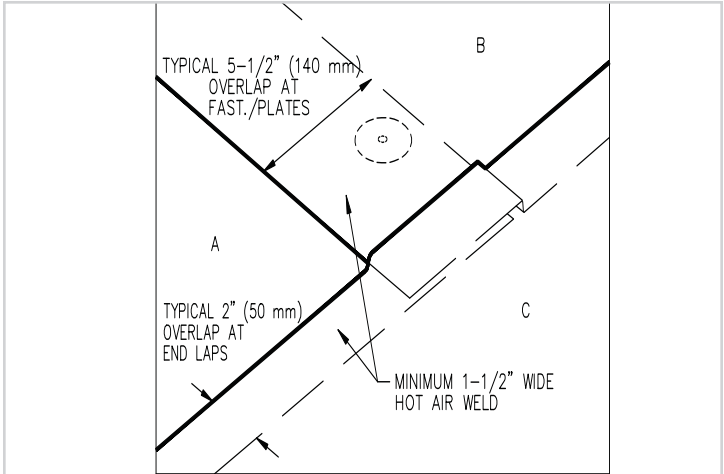

- ① POSITION SHEETS AND HOT AIR WELD THE .060" (1.5 mm) THICK FLEX TPO MEMBRANE A MINIMUM OF 1-1/2" (40 mm).

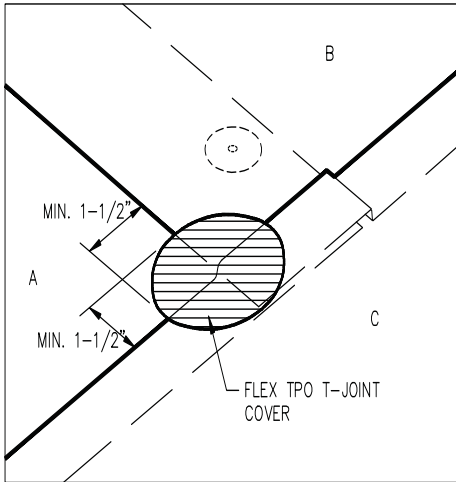

- ② INSTALL A 4.5" DIAMETER FLEX TPO T-JOINT COVER CENTERED OVER THE SPLICE INTERSECTION ("T-JOINT") AS SHOWN.

TITLE	
60 MIL & 80 MIL T-JOINT DETAIL	
NAME	
DETAIL NO. 2.06	
DRAWN BY:	DATE:
KF	11/2008
APPLICABLE TO ALL FLEX TPO	
MECHANICALLY FASTENED SYSTEMS	
FLEX MEMBRANE INTERNATIONAL	LEESPORT, PA 19533 800-969-0108 FlexRoofingSystems.com

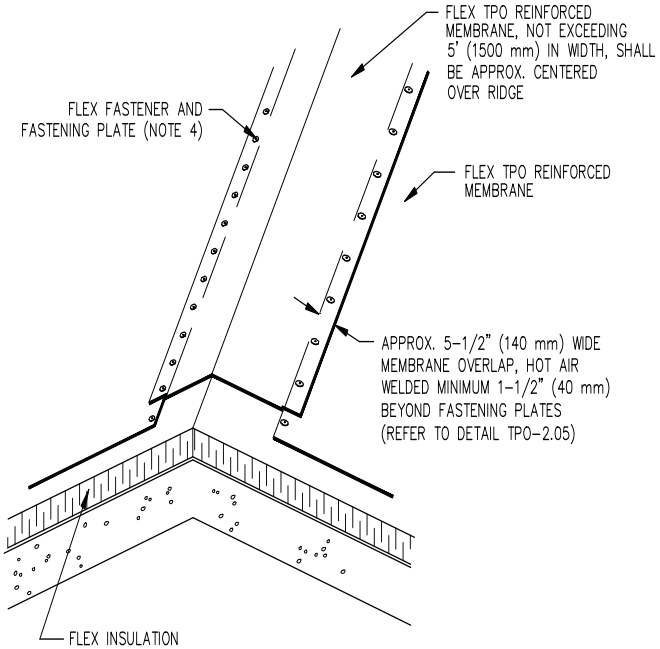

NOTES

1. RIDGE MEMBRANE ATTACHMENT IS ONLY REQUIRED WHEN ROOF SLOPE EXCEEDS 1" (75 mm) TO ONE HORIZONTAL FOOT.
2. POSITION FASTENING PLATES 1/2" (13 mm) MINIMUM TO 1" (25 mm) MAXIMUM FROM THE EDGE OF THE DECK MEMBRANE.
3. APPROXIMATELY 1/8" (3 mm) DIAMETER BEAD OF CUT-EDGE SEALANT IS REQUIRED ON CUT EDGES OF FLEX TPO REINFORCED MEMBRANE.
4. REFER TO SPECIFICATION FOR ACCEPTABLE FLEX FASTENERS, PLATES AND OTHER FASTENING DENSITIES.

TITLE	
RIDGE MEMBRANE ATTACHMENT	
NAME	
DETAIL NO. 2.07	
DRAWN BY:	DATE:
KF	11/2008
APPLICABLE TO ALL FLEX TPO	
MECHANICALLY FASTENED SYSTEMS	
FLEX	
MEMBRANE	
INTERNATIONAL	
LEESPORT, PA 19533	
800-969-0108	
FlexRoofingSystems.com	

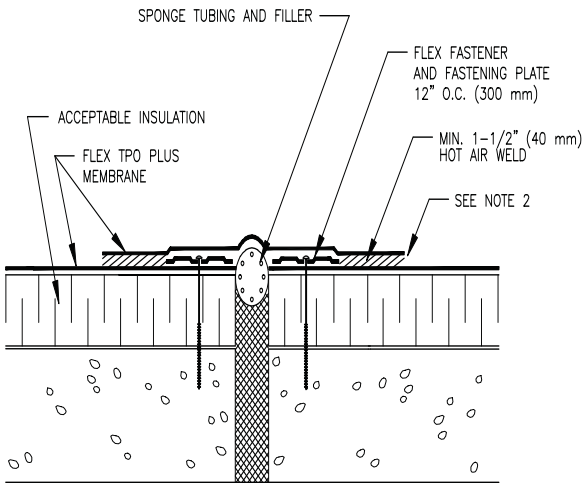
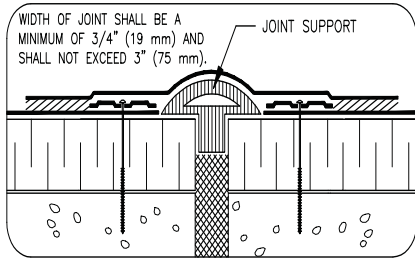

NOTES:

1. POSITION FASTENING PLATES 1/2" (13 mm) MINIMUM TO 1" (25 mm) MAXIMUM FROM EDGE OF DECK MEMBRANE.
2. APPROXIMATELY 1/8" (3 mm) DIAMETER BEAD OF CUT-EDGE SEALANT IS REQUIRED ON CUT EDGES OF FLEX TPO PLUS MEMBRANE.
3. REFER TO MANUFACTURERES APPROVALS FOR MEMBRANE FASTENING CRITERIA FOR PROPER FASTENERS AND PLATES.

TITLE	
LOW PROFILE EXPANSION JOINT	
NAME	
DETAIL NO. 3.01	
DRAWN BY:	DATE:
KF	11/2008
APPLICABLE TO ALL FLEX TPO	
MECHANICALLY FASTENED SYSTEMS	
FLEX MEMBRANE INTERNATIONAL	LEESPORT, PA 19533 800-969-0108 FlexRoofingSystems.com

CREASE MEMBRANE AT ANGLE CHANGE TO
LIMIT BRIDGING TO 3/4" (19 mm) MAXIMUM

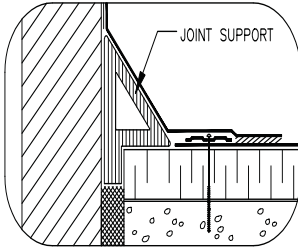

WIDTH OF JOINT SHALL BE A
MINIMUM OF 3/4" (19 mm) AND
SHALL NOT EXCEED 2" (50 mm).

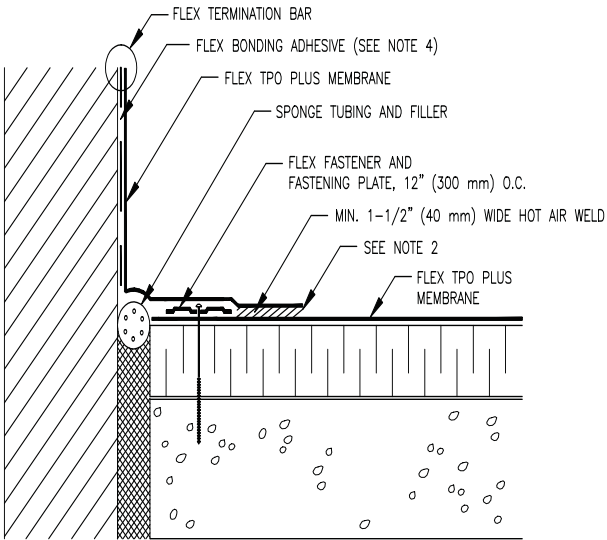

NOTES:

1. POSITION FASTENING PLATES 1/2" (13 mm) MINIMUM TO 1" (25 mm) MAXIMUM FROM EDGE OF DECK FLANGE.
2. APPROXIMATELY 1/8" (3 mm) DIAMETER BEAD OF EDGE SEALANT IS REQUIRED ON CUT EDGES OF FLEX TPO PLUS MEMBRANE.
3. REFER TO MANUFACTURES APPROVALS FOR MEMBRANE FASTENING CRITERIA FOR PROPER FASTENERS AND PLATES.
4. FLEX BONDING ADHESIVE IS REQUIRED REGARDLESS OF TERMINATION HEIGHT.

TITLE EXPANSION JOINT @ WALL	
NAME DETAIL NO. 3.02	
DRAWN BY: KF	DATE: 11/2008
APPLICABLE TO ALL FLEX TPO	
MECHANICALLY FASTENED SYSTEMS	
FLEX MEMBRANE INTERNATIONAL	LEESPORT, PA 19533 800-969-0108 FlexRoofingSystems.com

CREASE MEMBRANE AT ANGLE CHANGE TO
LIMIT BRIDGING TO 3/4" (19 mm) MAXIMUM

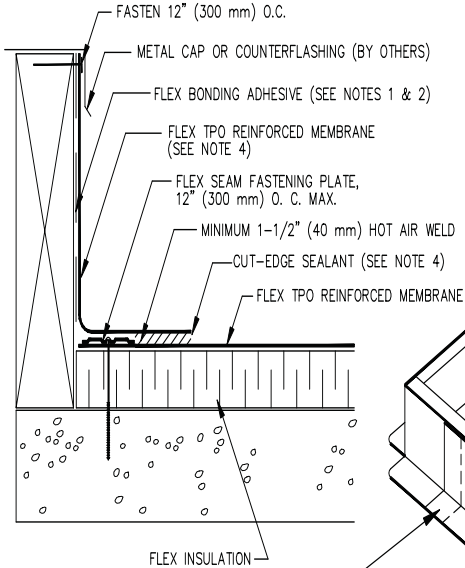

USE ONE CONTINUOUS SHEET
OF FLEX TPO REINFORCED
MEMBRANE TO WRAP AROUND
CURB OR FORM FROM COATED
METAL

INSTALL OUTSIDE
CORNERS PER
DETAIL TPO-15B

NOTES:

1. BONDING ADHESIVE IS NOT REQUIRED WHEN FLASHING HEIGHT IS 12" (300 mm) OR LESS AND MEMBRANE IS FASTENED "AS SHOWN" AT TOP OF CURB.
2. WHEN FLEX TERMINATION BAR IS USED BENEATH THE COUNTERFLASHING, BONDING ADHESIVE CAN BE ELIMINATED WHEN THE FLASHING HEIGHT IS 18" (500 mm) OR LESS.
3. FLASHING MEMBRANE FASTENED APPROXIMATELY 12" ON CENTER. IF FASTENER PENETRATES METAL COUNTERFLASHING, USE NEOPRENE WASHER OR APPLY WATER CUT-OFF MASTIC UNDER COUNTERFLASHING OR CAULK FASTENER HEAD.
4. APPROXIMATELY 1/8" (3 mm) BEAD OF CUT-EDGE SEALANT IS REQUIRED ON CUT EDGES OF FLEX TPO PLUS REINFORCED MEMBRANE.
5. REFER TO SPECIFICATION FOR ACCEPTABLE FLEX TPO PLUS FASTENERS AND PLATES.
6. FOR CORNER FLASHING, REFER TO APPLICABLE FLEX DETAIL.

TITLE	CURB FLASHING	
NAME	DETAIL NO. 3.03	
DRAWN BY:	KF	DATE: 11/2008
APPLICABLE TO ALL FLEX TPO		
MECHANICALLY FASTENED SYSTEMS		
FLEX MEMBRANE INTERNATIONAL	LEESPORT, PA 19533 800-969-0108 FlexRoofingSystems.com	

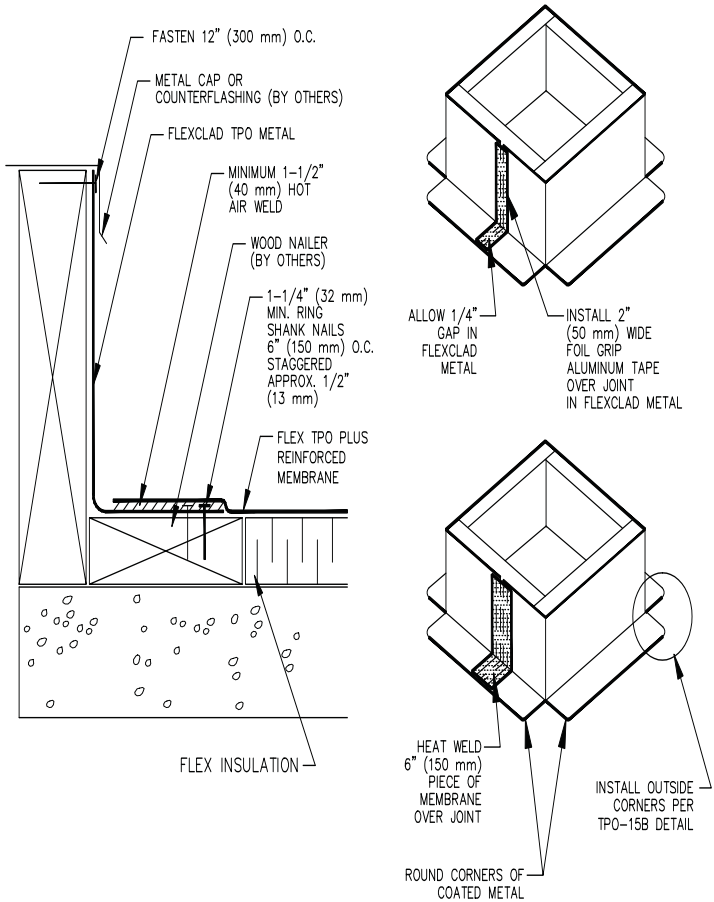

NOTE:

1. COATED METAL FLASHING FASTENED APPROXIMATELY 6" (150 mm) ON CENTER. IF FASTENER PENETRATES METAL COUNTERFLASHING, USE NEOPRENE WASHER OR APPLY WATER CUT-OFF MASTIC UNDER COUNTERFLASHING OR CAULK FASTENER HEAD.
2. APPROXIMATELY 1/8" (3 mm) DIAMETER OF CUT-EDGE SEALANT IS REQUIRED ON CUT EDGES OF FLEX TPO REINFORCED MEMBRANE.

TITLE	
COATED METAL CURB FLASHING	
NAME	
DETAIL NO. 3.04	
DRAWN BY:	DATE:
KF	11/2008
APPLICABLE TO ALL FLEX TPO	
MECHANICALLY FASTENED SYSTEMS	
FLEX MEMBRANE INTERNATIONAL	LEESPORT, PA 19533 800-969-0108 FlexRoofingSystems.com

CREASE MEMBRANE AT ANGLE CHANGE TO
LIMIT BRIDGING TO 3/4" (19 mm) MAXIMUM

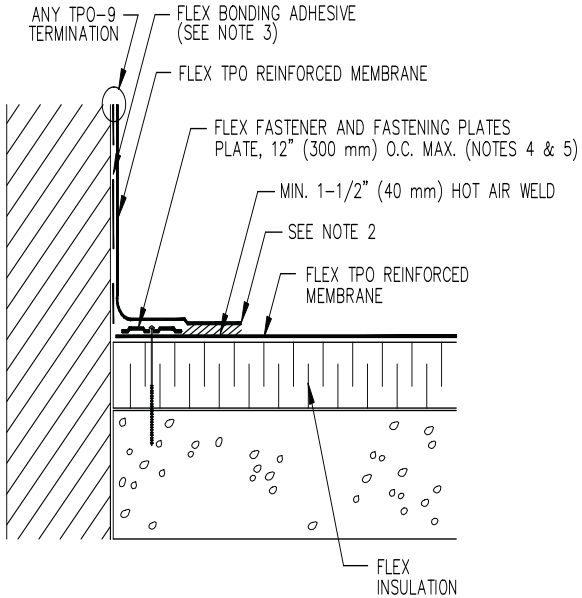

NOTES:

1. POSITION FASTENING PLATES 1/2" (13 mm) TO 1" (25 mm) FROM EDGE OF DECK MEMBRANE.
2. APPROXIMATELY 1/8" (3 mm) DIAMETER BEAD OF CUT-EDGE SEALANT IS REQUIRED ON CUT EDGES OF FLEX TPO REINFORCED MEMBRANE.
3. WHEN COUNTERFLASHING IS USED FOR TERMINATION, BONDING ADHESIVE IS NOT REQUIRED WHEN FLASHING HEIGHT IS 12" (300 mm) OR LESS. WHEN COPING OR A TERMINATION BAR IS USED, ADHESIVE MAY BE ELIMINATED WHEN FLASHING HEIGHT IS 18" (500 mm) OR LESS.
4. FLEX XHD FASTENER AND PLATE OR FLEX SXHD FASTENER AND PLATE ARE REQUIRED OVER STEEL AND WOOD DECKS. REFER TO MANUFACTURERS APPROVALS FOR MEMBRANE FASTENING CRITERIA FOR PROPER FASTENERS AND PLATES.
5. FASTENING PLATES CAN BE INSTALLED VERTICALLY.

TITLE		PARAPET FLASHING	
NAME		DETAIL NO. 3.06	
DRAWN BY:	DATE:	KF	11/2008
APPLICABLE TO ALL FLEX TPO			
MECHANICALLY FASTENED SYSTEMS			
FLEX MEMBRANE INTERNATIONAL		LEESPORT, PA 19533 800-969-0108 FlexRoofingSystems.com	

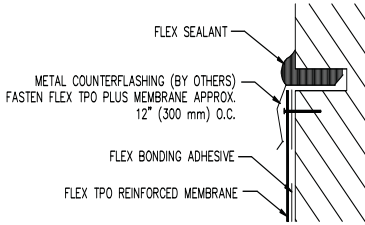

NOTES:

1. COUNTERFLASHING SHALL BE ELEVATED ABOVE PONDED WATER.
2. NOT FOR USE ON 15 YEAR WARRANTY PROJECTS (REFER TO DETAIL TPO 9F).
3. BONDING ADHESIVE IS NOT REQUIRED WHEN FLASHING HEIGHT IS 12" (300 mm) OR LESS.

TPO-9C COUNTERFLASHING TERMINATION

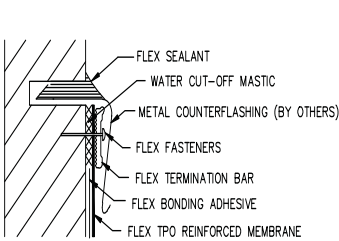

1. APPLY ON HARD SMOOTH SURFACE ONLY; NOT FOR USE ON WOOD.
2. DO NOT WRAP COMPRESSION TERMINATION AROUND CORNERS.
3. FASTENERS OF METAL BAR MUST PROVIDE CONSTANT COMPRESSION ON WATER CUT-OFF MASTIC.

TPO-9F MECHANICAL TERMINATION

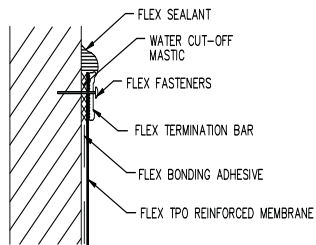

4. ALLOW 1/4" to 1/2" (6 to 13 mm) SPACING BETWEEN CONSECUTIVE LENGTHS OF TERMINATION BAR.
5. BONDING ADHESIVE IS NOT REQUIRED WHEN FLASHING IS 18" (500 mm) OR LESS.

TPO-9D MECHANICAL TERMINATION

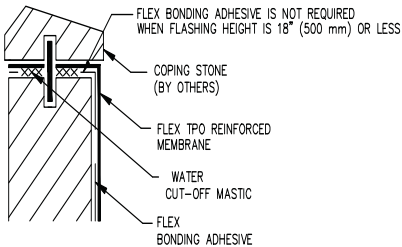

TPO-9E COPING STONE TERMINATION

TITLE	
FLASHING TERMINATIONS	
NAME	
DETAIL NO. 3.08	
DRAWN BY:	DATE:
KF	11/2008
APPLICABLE TO ALL FLEX TPO	
MECHANICALLY FASTENED SYSTEMS	
FLEX MEMBRANE INTERNATIONAL	LEESPORT, PA 19533 800-969-0108 FlexRoofingSystems.com

FOR DRAINS WITH TAPERED
INSULATION AT DRAIN SUMP
LESS THAN 3 INCHES TO 1
HORIZONTAL FOOT
(75 mm/300 mm)

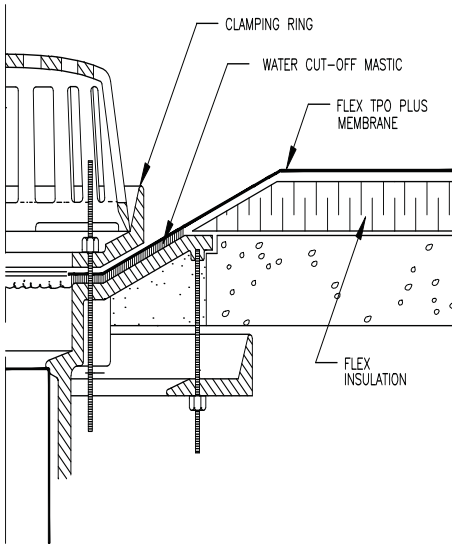
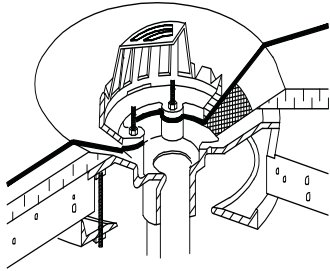

NOTES:

1. REMOVE ALL LEAD AND OTHER FLASHING.
2. ALL BOLTS AND CLAMPS MUST BE IN PLACE TO PROVIDE CONSTANT COMPRESSION ON WATER CUT-OFF MASTIC.
3. CUT THE MEMBRANE SO IT EXTENDS A MINIMUM OF 1/2" (13 mm) FROM THE ATTACHMENT POINTS OF THE DRAIN CLAMPING RING.
4. FOR DRAIN SUMPS WITH SLOPES GREATER THAN 3" (75 mm) IN 12" (300 mm) REFER TO DETAIL TPO 4.02.
5. IT IS PREFERRED TO LOCATE SPLICES AT LEAST 6" (150 mm) OUTSIDE DRAIN SUMP. IF SPLICES EXTEND UNDER CLAMPING RING, ENTIRE SPLICE OVERLAP MUST BE HOT AIR WELDED.

TITLE	
ROOF DRAIN	
NAME	
DETAIL NO. 4.01	
DRAWN BY:	DATE:
KF	11/2008
APPLICABLE TO ALL FLEX TPO	
MECHANICALLY FASTENED SYSTEMS	
FLEX MEMBRANE INTERNATIONAL	LEESPORT, PA 19533 800-969-0108 FlexRoofingSystems.com

FOR DRAINS WITH TAPERED INSULATION AT DRAIN SUMP
GREATER THAN 3" TO 1 HORIZONTAL FOOT (75 mm/300 mm)

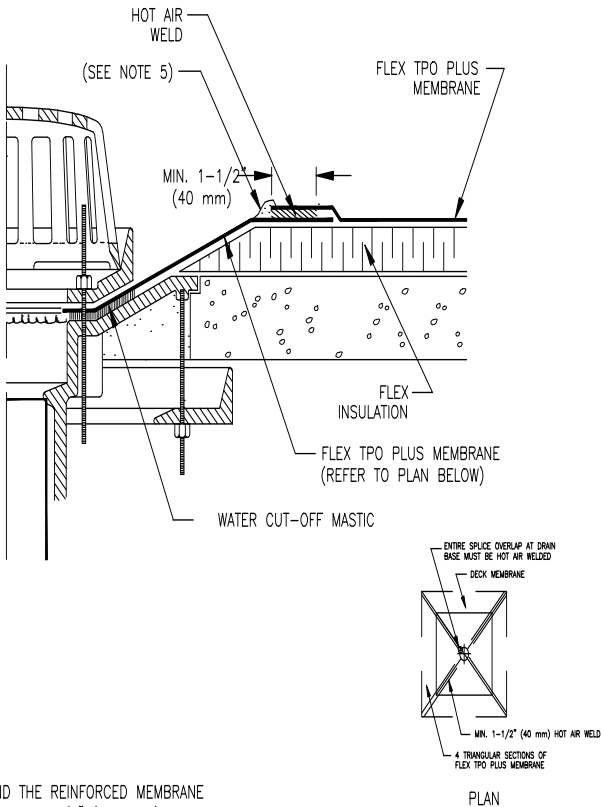

NOTES:

1. EXTEND THE REINFORCED MEMBRANE APPROXIMATELY 5-1/2" (140 mm) OUT OF THE SUMP AREA.
2. REMOVE ALL LEAD AND OTHER FLASHING.
3. ALL BOLTS OR CLAMPS MUST BE IN PLACE TO PROVIDE COMPRESSION ON WATER CUT-OFF MASTIC.
4. CUT THE MEMBRANE SO IT EXTENDS A MINIMUM OF 1/2" (13 mm) FROM THE ATTACHMENT POINTS OF THE DRAIN CLAMPING RING.
5. APPROXIMATELY 1/8" (3 mm) DIAMETER BEAD OF CUT-EDGE SEALANT IS REQUIRED ON CUT EDGE OF FLEX TPO PLUS MEMBRANE.

TITLE	
ROOF DRAIN II	
NAME	
DETAIL NO. 4.02	
DRAWN BY:	DATE:
KF	11/2008
APPLICABLE TO ALL FLEX TPO	
MECHANICALLY FASTENED SYSTEMS	
FLEX MEMBRANE INTERNATIONAL	
LEESPORT, PA 19533 800-969-0108 FlexRoofingSystems.com	

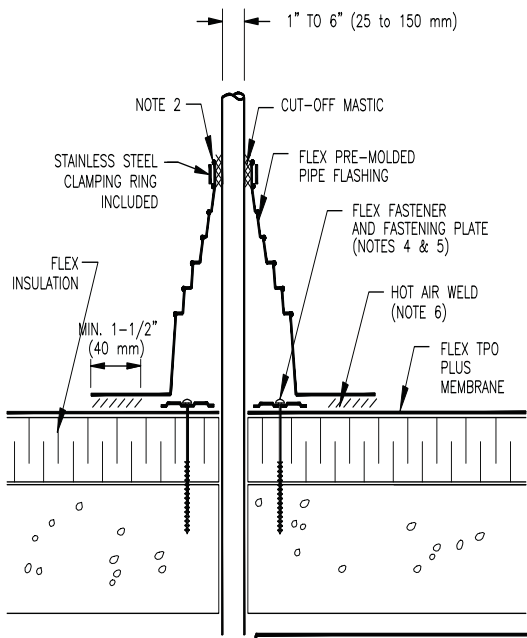

NOTES:

1. REMOVE ALL LEAD AND OTHER FLASHING.
2. TEMPERATURE OF PIPE MUST NOT EXCEED 120° F (49° C).
3. PIPE SEAL MUST HAVE INTACT RIB AT TOP EDGE, REGARDLESS OF PIPE DIAMETER.
4. INSTALL 3 FASTENERS AND PLATES AROUND PIPE EQUALLY SPACED. FASTENERS MAY ALSO BE POSITIONED MAXIMUM 12" (300 mm) FROM PIPE, FASTENED 12" ON CENTER AND FLASHED WITH FLEX TPO PLUS MEMBRANE.

FASTENERS/PLATES ARE NOT REQUIRED ON ADHERED SYSTEMS UNLESS PIPE DIAMETER EXCEEDS 18" (500 m).

5. IF PLATES CANNOT BE INSTALLED AS SHOWN THEY CAN BE POSITIONED OUTSIDE THE PIPE FLASHING FLANGE AS SHOWN ON DETAIL FLEX TPO 8F

6. PIPE FLASHING DECK FLANGE MUST BE HOT AIR WELDED A MINIMUM OF 1-1/2" (40MM) BEYOND FASTENING PLATES

7. INSTALL A SECTION OF FLEX TPO PLUS MEMBRANE OVER SPLICE INTERSECTIONS PRIOR TO INSTALLING PRE-MOLDED PIPE FLASHING

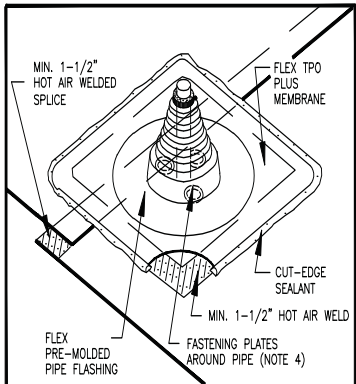

TITLE	
PRE-MOLDED PIPE FLASHING	
NAME	
DETAIL NO. 4.03	
DRAWN BY:	DATE:
KF	11/2008
APPLICABLE TO ALL FLEX TPO	
MECHANICALLY FASTENED SYSTEMS	
FLEX MEMBRANE INTERNATIONAL	LEESPORT, PA 19533 800-969-0108 FlexRoofingSystems.com

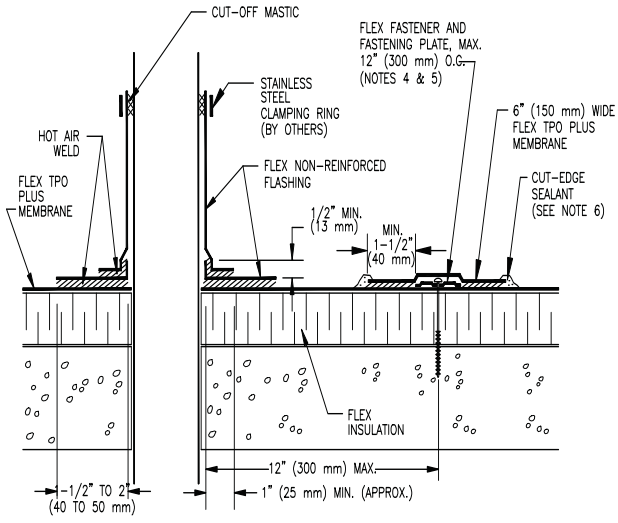

**APPLY HEAT TO FLASHING AND FORM BY HAND
PRIOR TO HOT AIR WELDING**

NOTES:

1. REMOVE ALL LEAD AND OTHER FLASHING BEFORE INSTALLING FIELD FABRICATED PIPE SEAL.
2. TEMPERATURE OF PIPE MUST NOT EXCEED 120° F (49° C).
3. FLEX NON-REINFORCED MEMBRANE WRAPPED AROUND PIPE SHALL HAVE MINIMUM 1-1/2" (40 mm) VERTICAL HOT AIR WELD.
4. INSTALL A MINIMUM OF 4 FASTENING PLATES AROUND PIPES WITH A DIAMETER UP TO 6" (150 mm). ADDITIONAL FASTENING PLATES WILL BE REQUIRED FOR PIPES GREATER THAN 6" IN DIAMETER AND SHALL BE SPACED 12" (300 mm) ON CENTER MAXIMUM.

FASTENERS/PLATES ARE NOT REQUIRED ON ADHERED SYSTEMS UNLESS PIPE DIAMETER EXCEEDS 18" (500 mm).

5. REFER TO MANUFACTURERS APPROVALS FOR MEMBRANE FASTENING CRITERIA FOR PROPER FASTENERS AND PLATES.

6. APPROXIMATELY 1/8" (3 mm) DIAMETER BEAD OF CUT-EDGE SEALANT IS REQUIRED ON CUT EDGES OF FLEX TPO PLUS REINFORCED MEMBRANE.

TITLE	
FIELD FABRICATED PIPE FLASHING	
NAME	
DETAIL NO. 4.04	
DRAWN BY:	DATE:
KF	11/2008
APPLICABLE TO ALL FLEX TPO	
MECHANICALLY FASTENED SYSTEMS	
FLEX MEMBRANE INTERNATIONAL	LEESPORT, PA 19533 800-969-0108 FlexRoofingSystems.com

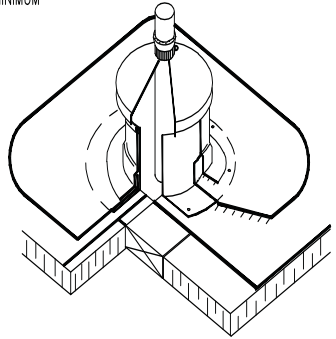
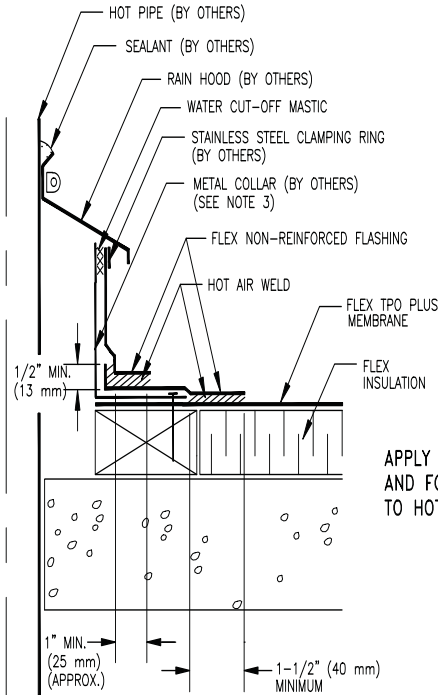

NOTES:

1. FIELD-FABRICATED PIPE SEAL FOR USE WITH HOT PIPE, 120° F (49° C) OR HOTTER.
2. FLEX NON-REINFORCED MEMBRANE WRAPPED AROUND PIPE SHALL HAVE MINIMUM 1-1/2" (40 mm) VERTICAL HOT AIR WELD.
3. TEMPERATURE OF METAL COLLAR MUST NOT EXCEED 120° F.

TITLE	
HOT PIPE FLASHING	
NAME	
DETAIL NO. 4.05	
DRAWN BY:	DATE:
KF	11/2008
APPLICABLE TO ALL FLEX TPO	
MECHANICALLY FASTENED SYSTEMS	
FLEX	
MEMBRANE	
INTERNATIONAL	
LEESPORT, PA 19533	
800-969-0108	
FlexRoofingSystems.com	

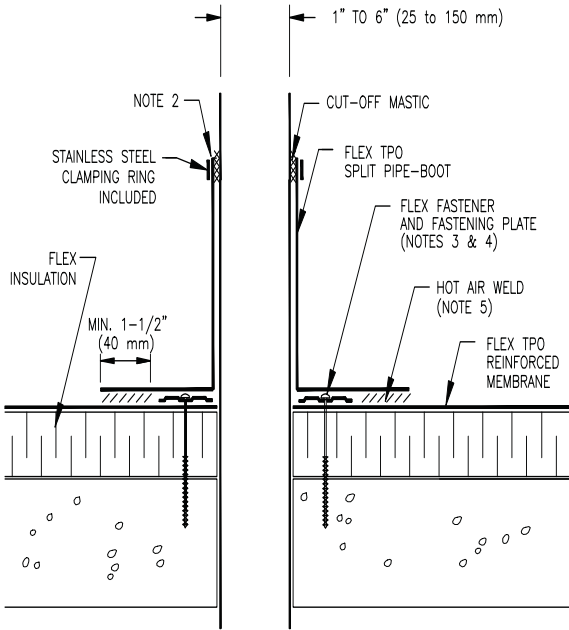

NOTES:

1. REMOVE ALL LEAD AND OTHER FLASHING.
2. TEMPERATURE OF PIPE MUST NOT EXCEED 120° F (49° C).
3. INSTALL 4 FASTENERS AND PLATES AROUND PIPE EQUALLY SPACED. FASTENERS MAY ALSO BE POSITIONED MAXIMUM 12" (300 mm) FROM PIPE, FASTENED 12" ON CENTER AND FLASHED WITH FLEX TPO REINFORCED MEMBRANE.

FASTENERS/PLATES ARE NOT REQUIRED ON ADHERED SYSTEMS UNLESS PIPE DIAMETER EXCEEDS 18" (500 m).

4. IF PLATES CANNOT BE INSTALLED AS SHOWN THEY CAN BE POSITIONED OUTSIDE THE PIPE FLASHING FLANGE
5. PIPE FLASHING DECK FLANGE MUST BE HOT AIR WELDED A MINIMUM OF 1-1/2" (40 mm) BEYOND FASTENING PLATES.

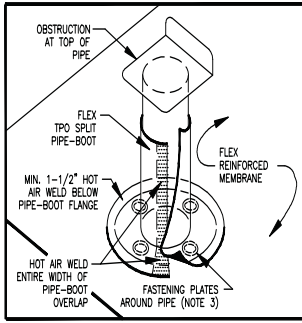

TITLE	
FLEX TPO SPLIT PIPE BOOT	
NAME	
DETAIL NO. 4.06	
DRAWN BY:	DATE:
KF	11/2008
APPLICABLE TO ALL FLEX TPO	
MECHANICALLY FASTENED SYSTEMS	
FLEX MEMBRANE INTERNATIONAL	LEESPORT, PA 19533 800-969-0108 FlexRoofingSystems.com

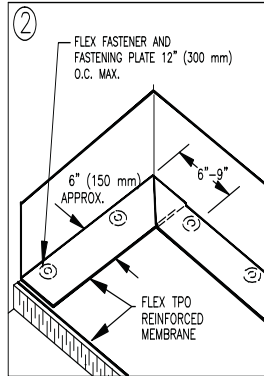
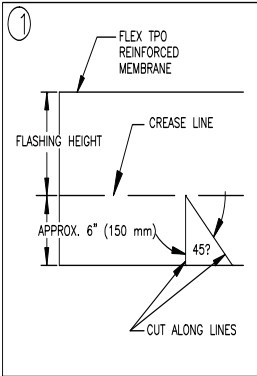

NOTES:

1. BEGIN INSTALLATION OF FASTENING PLATES 6" TO 9" (150 TO 230 mm) FROM THE CORNER.
2. POSITION FASTENING PLATES 1/2" TO 1" (13 mm to 25 mm) FROM EDGE OF MEMBRANE.
3. APPROXIMATELY 1/8" (13 mm) DIAMETER BEAD OF CUT-EDGE SEALANT IS REQUIRED ON CUT EDGES OF FLEX TPO REINFORCED MEMBRANE.
4. REFER TO SPECIFICATION FOR ACCEPTABLE FLEX FASTENERS AND PLATES.

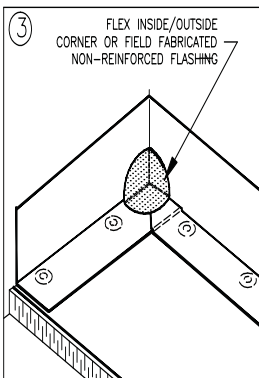

TITLE	INSIDE CORNER FLASHING	
NAME	DETAIL NO. 5.01	
DRAWN BY:	KF	DATE: 11/2008
APPLICABLE TO ALL FLEX TPO		
MECHANICALLY FASTENED SYSTEMS		
FLEX MEMBRANE INTERNATIONAL	LEESPORT, PA 19533 800-969-0108 FlexRoofingSystems.com	

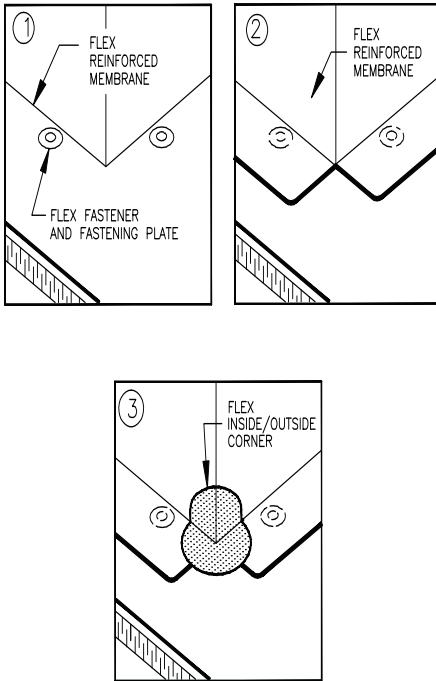

NOTES:

1. BEGIN INSTALLATION OF FASTENING PLATES APPROXIMATELY 6" (150 mm) FROM CORNER.
2. POSITION FASTENING PLATES 1/2" TO 1" (13 mm to 25 mm) FROM EDGE OF DECK MEMBRANE.
3. APPROXIMATELY 1/8" (3 mm) DIAMETER BEAD OF CUT-EDGE SEALANT IS REQUIRED ON CUT EDGES OF FLEX TPO REINFORCED MEMBRANE.
4. REFER TO SPECIFICATION FOR ACCEPTABLE FASTENERS AND PLATES.

TITLE	PRE-MOLDED OUTSIDE CORNER	
NAME	DETAIL NO. 5.02	
DRAWN BY:	KF	DATE: 11/2008
APPLICABLE TO ALL FLEX TPO		
MECHANICALLY FASTENED SYSTEMS		
FLEX MEMBRANE INTERNATIONAL	LEESPORT, PA 19533 800-969-0108 FlexRoofingSystems.com	

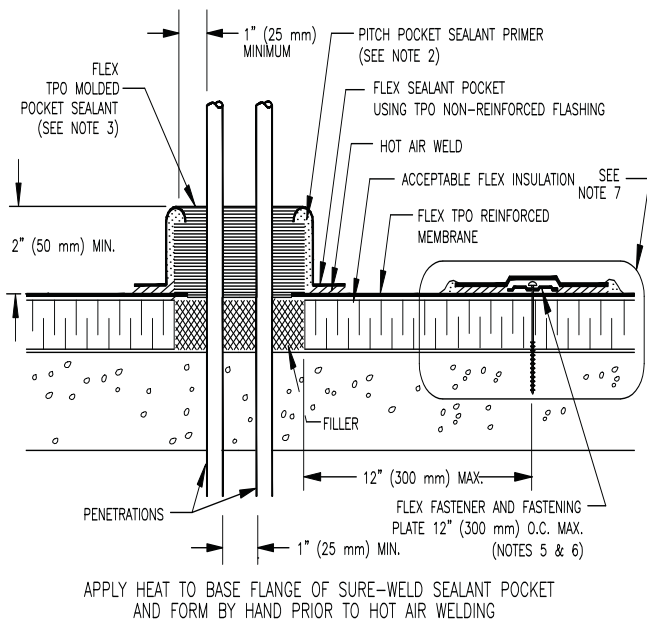

NOTES:

- TEMPERATURE OF PIPE MUST NOT EXCEED 120° F (49° C).
- FLEX PITCH PAN SEALANT PRIMER MUST BE APPLIED TO ALL INSIDE SURFACES AND PENETRATIONS PRIOR TO FILLING WITH SEALANT.
- FILL POCKET COMPLETELY WITH TPO MOLDED POCKET SEALANT UNTIL RIM IS COVERED WITH SEALANT; ENSURE ALL VOIDS ARE FILLED.
- SEALANT POCKET TO BE MINIMUM 1" (25 mm) FROM PENETRATION ON ANY SIDE.

5. ON MECHANICALLY-FASTENED SYSTEMS, INSTALL A MINIMUM OF 4 FASTENING PLATES AROUND SEALANT POCKETS WITH A DIAMETER UP TO 6' (150MM). ADDITIONAL FASTENING PLATES WILL BE REQUIRED FOR SEALANT POCKETS GREATER THAN 6' IN DIAMETER AND SHALL BE SPACED 12' (300MM) ON CENTER MAXIMUM. FASTENERS/PLATES ARE NOT REQUIRED ON ADHERED SYSTEMS UNLESS SEALANT POCKET DIAMETER EXCEEDS 12' (300MM)

6. REFER TO MANUFACTURERS APPROVALS FOR MEMBRANE FASTENING CRITERIA, MEMBRANE FASTENING CRITERIA, FOR PROPER FASTENERS AND PLATES.

7. APPROXIMATELY 1/8" (3MM) DIAMETER BEAD OF FLEX CUT-EDGE SEALANT IS REQUIRED ON CUT EDGES OF FLEX TPO REINFORCED MEMBRANE

TITLE	
FLEX TPO PITCH POCKET	
NAME	
DETAIL NO. 5.04	
DRAWN BY:	DATE:
KF	11/2008
APPLICABLE TO ALL FLEX TPO	
MECHANICALLY FASTENED SYSTEMS	
FLEX MEMBRANE INTERNATIONAL	LEESPORT, PA 19533 800-969-0108 FlexRoofingSystems.com

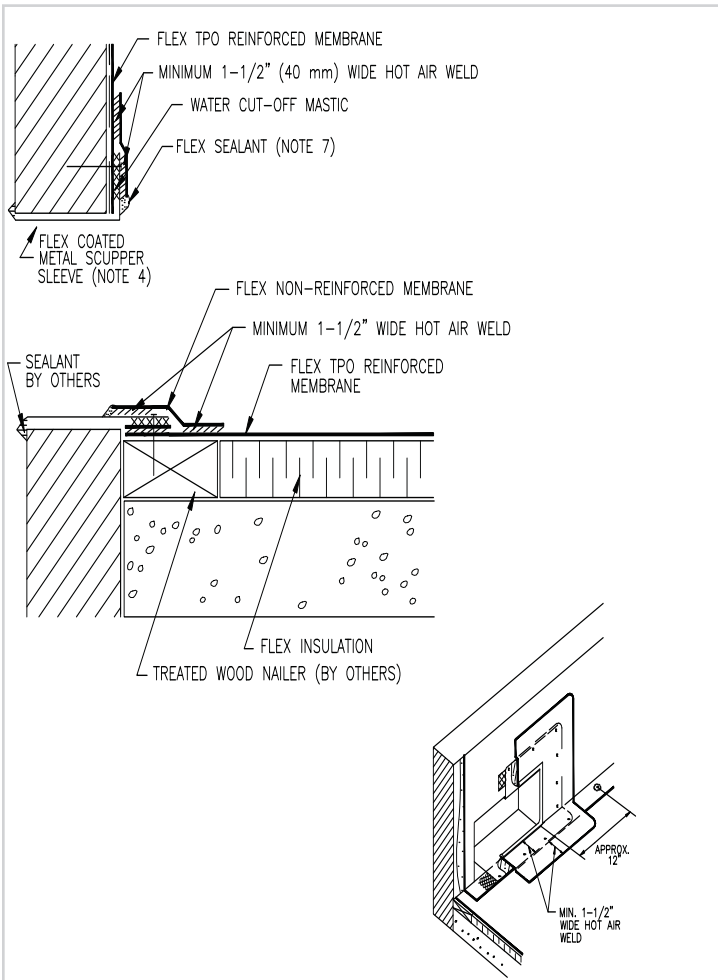

NOTES:

1. TREATED WOOD NAILER MUST EXTEND PAST TOTAL WIDTH OF DECK FLANGE.
2. INSTALL WALL FLASHING PRIOR TO SCUPPER INSTALLATION.
3. DISCONTINUE FASTENING PLATES AT SCUPPER OPENING AS SHOWN.
4. METAL SCUPPER BOX MUST HAVE CONTINUOUS SIDES; METAL FLANGE MUST BE CONTINUOUS WITH ROUNDED CORNERS.
5. WATER CUT-OFF MASTIC UNDER SCUPPER FLANGE MUST BE UNDER CONSTANT COMPRESSION.
6. MINIMUM 2" (50 mm) SPLICE FROM NAIL HEAD.
7. APPROVED SEALANT IS REQUIRED AT FLASHING EDGE ON SCUPPER EDGE. PRIMER MUST BE USED TO PREPARE SURFACES PRIOR TO APPLYING FLEX SEALANT.

TITLE		THROUGH WALL SCUPPER	
NAME		DETAIL NO. 5.05	
DRAWN BY:	KF	DATE:	11/2008
APPLICABLE TO ALL FLEX TPO			
MECHANICALLY FASTENED SYSTEMS			
FLEX MEMBRANE INTERNATIONAL		LEESPORT, PA 19533 800-969-0108 FlexRoofingSystems.com	

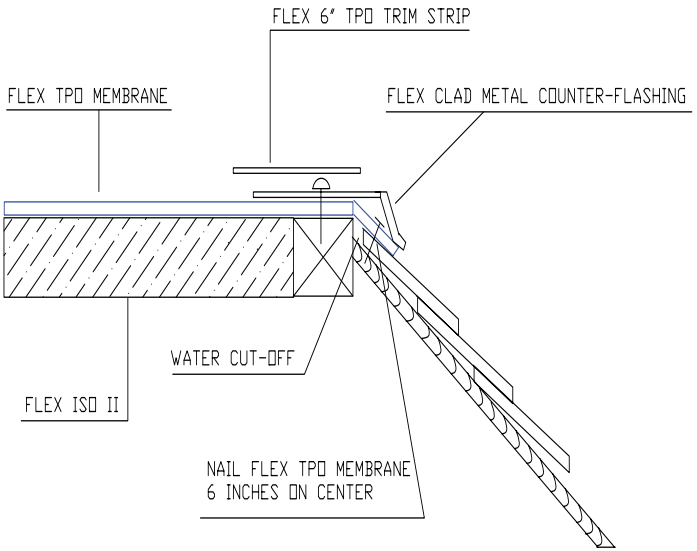

TITLE	SHINGLE TIE IN	
NAME	DETAIL NO. 5.06	
DRAWN BY:	KF	DATE: 08/2009
APPLICABLE TO ALL		
FLEX TPO ROOF SYSTEMS		
FLEX MEMBRANE INTERNATIONAL	2670 LEISCZ'S BRIDGE RD. LEESPORT, PA 19533 800-969-0108 FlexRoofingSystems.com	

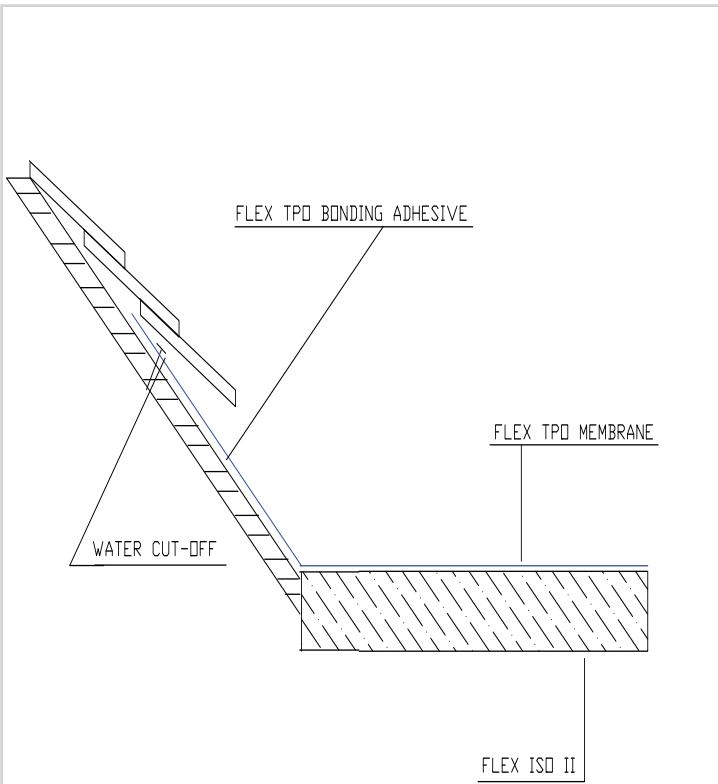

NOTE:

- FLEX TPO MEMBRANE MUST BE EXTENDED A MINIMUM OF 6' UNDER THE SECOND COURSE OF SHINGLES

TITLE	SHINGLE TIE IN	
NAME	DETAIL NO. 82805 5.07	
DRAWN BY:	KF	DATE: 08/2009
APPLICABLE TO ALL		
FLEX TPO ROOF SYSTEMS		
FLEX MEMBRANE INTERNATIONAL	2670 LEISCZ'S BRIDGE RD. LEESPORT, PA 19533 800-969-0108 FlexRoofingSystems.com	

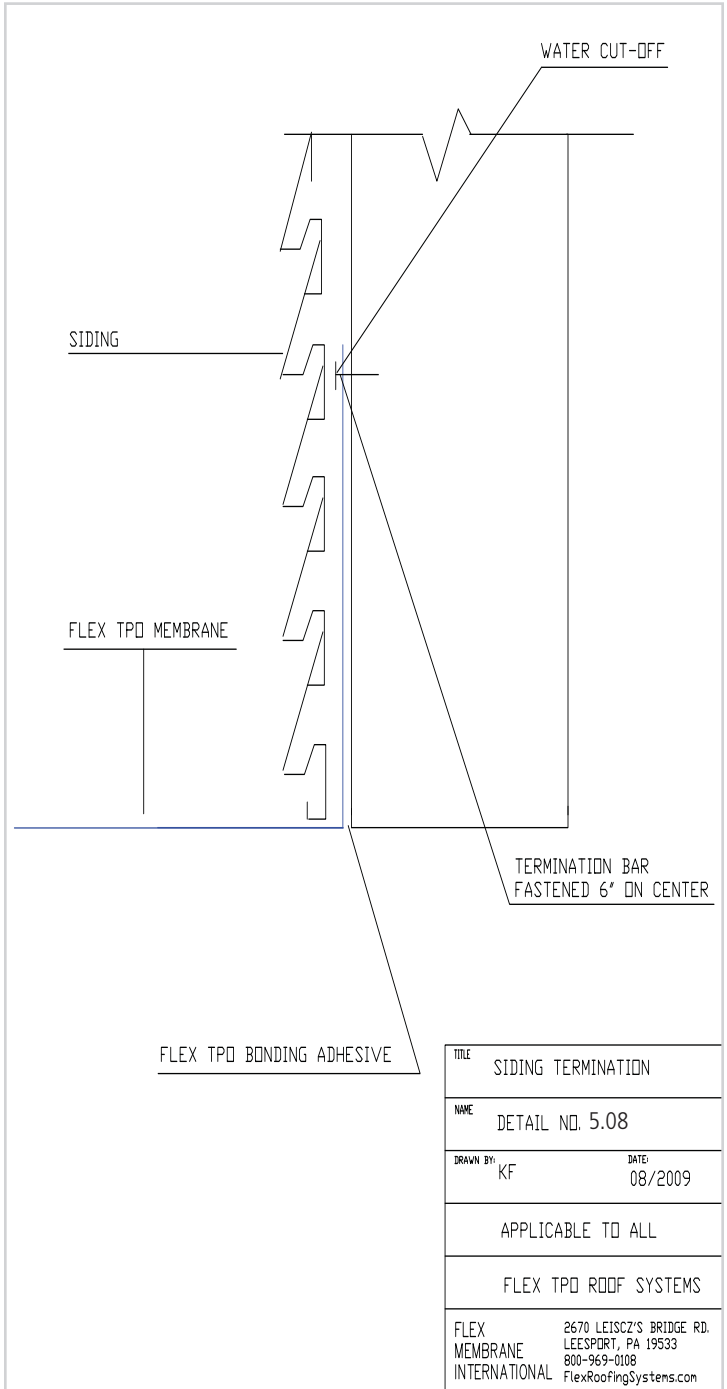

TITLE	
SIDING TERMINATION	
NAME	
DETAIL NO. 5.08	
DRAWN BY:	DATE:
KF	08/2009
APPLICABLE TO ALL	
FLEX TPO ROOF SYSTEMS	
FLEX MEMBRANE INTERNATIONAL	2670 LEISCZ'S BRIDGE RD. LEESPORT, PA 19533 800-969-0108 FlexRoofingSystems.com

Flex Membrane International, Inc.

2670 Leisz's Bridge Road, Suite 400,

Leesport, PA 19533

Phone: 1-800-969-0108

Fax: 610-916-9501

FLEX TPO MEMBRANES**.045 Thickness****.045 Thickness FLEX WHITE Reinforced TPO Membrane**

Item Code	Roll Size	Gross Coverage	Weight
8300	4' X 100'	400 sq. ft.	95 lbs.
8425	5' X 50'	250 sq. ft.	58 lbs.
8405	5' X 100'	500 sq. ft.	115 lbs.
8301	6' X 100'	600 sq. ft.	143 lbs.
8303	8' X 100'	800 sq. ft.	192 lbs.
8426	10' X 50'	500 sq. ft.	125 lbs.
8302	10' X 100'	1,000 sq. ft.	249 lbs.
8340	12' X 100'	1,200 sq. ft.	292 lbs.

.045 Thickness FLEX GRAY Reinforced TPO Membrane

Item Code	Roll Size	Gross Coverage	Weight
8332	4' X 100'	400 sq. ft.	95 lbs.
8443	5' X 50'	250 sq. ft.	58 lbs.
8444	5' X 100'	500 sq. ft.	115 lbs.
8334	6' X 100'	600 sq. ft.	143 lbs.
8336	8' X 100'	800 sq. ft.	192 lbs.
8338	10' X 100'	1,000 sq. ft.	249 lbs.
8341	12' X 100'	1,200 sq. ft.	292 lbs.

.045 Thickness FLEX TAN Reinforced TPO Membrane

Item Code	Roll Size	Gross Coverage	Weight
8333	4' X 100'	400 sq. ft.	95 lbs.
8445	5' X 50'	250 sq. ft.	58 lbs.
8446	5' X 100'	500 sq. ft.	115 lbs.
8335	6' X 100'	600 sq. ft.	143 lbs.
8337	8' X 100'	800 sq. ft.	192 lbs.
8339	10' X 100'	1,000 sq. ft.	249 lbs.
8342	12' X 100'	1,200 sq. ft.	292 lbs.

Flex Membrane International, Inc.

2670 Leisch's Bridge Road, Suite 400,

Leesport, PA 19533

Phone: 1-800-969-0108

Fax: 610-916-9501

FLEX TPO MEMBRANES**.060 Thickness****.060 Thickness FLEX WHITE Reinforced TPO Membrane**

<u>Item Code</u>	<u>Roll Size</u>	<u>Gross Coverage</u>	<u>Weight</u>
8343	4' X 100'	400 sq. ft.	128 lbs.
8447	5' X 50'	250 sq. ft.	58 lbs.
8437	5' X 100'	500 sq. ft.	155 lbs.
8307	6' X 100'	600 sq. ft.	190 lbs.
8308	8' X 100'	800 sq. ft.	251 lbs.
8350	10' X 100'	1,000 sq. ft.	318 lbs.
8353	12' X 100'	1,200 sq. ft.	391 lbs.

.060 Thickness FLEX GRAY Reinforced TPO Membrane

<u>Item Code</u>	<u>Roll Size</u>	<u>Gross Coverage</u>	<u>Weight</u>
8344	4' X 100'	400 sq. ft.	128 lbs.
8448	5' X 50'	250 sq. ft.	58 lbs.
8449	5' X 100'	500 sq. ft.	115 lbs.
8346	6' X 100'	600 sq. ft.	190 lbs.
8348	8' X 100'	800 sq. ft.	251 lbs.
8351	10' X 100'	1,000 sq. ft.	318 lbs.
8354	12' X 100'	1,200 sq. ft.	391 lbs.

.060 Thickness FLEX TAN Reinforced TPO Membrane

<u>Item Code</u>	<u>Roll Size</u>	<u>Gross Coverage</u>	<u>Weight</u>
8345	4' X 100'	400 sq. ft.	128 lbs.
8450	5' X 50'	250 sq. ft.	58 lbs.
8451	5' X 100'	500 sq. ft.	115 lbs.
8347	6' X 100'	600 sq. ft.	190 lbs.
8349	8' X 100'	800 sq. ft.	251 lbs.
8352	10' X 100'	1,000 sq. ft.	318 lbs.
8355	12' X 100'	1,200 sq. ft.	391 lbs.

Flex Membrane International, Inc.

2670 Leisch's Bridge Road, Suite 400,

Leesport, PA 19533

Phone: 1-800-969-0108

Fax: 610-916-9501

FLEX TPO MEMBRANES**.072 Thickness****.072 Thickness FLEX WHITE Reinforced TPO Membrane**

<u>Item Code</u>	<u>Roll Size</u>	<u>Gross Coverage</u>	<u>Weight</u>
8360	4' X 100'	400 sq. ft.	153 lbs.
8452	5' X 50'	250 sq. ft.	58 lbs.
8453	5' X 100'	500 sq. ft.	115 lbs.
8362	6' X 100'	600 sq. ft.	228 lbs.
8356	8' X 100'	800 sq. ft.	305 lbs.
8358	10' X 100'	1,000 sq. ft.	388 lbs.
8364	12' X 100'	1,200 sq. ft.	499 lbs.

.072 Thickness FLEX GRAY Reinforced TPO Membrane

<u>Item Code</u>	<u>Roll Size</u>	<u>Gross Coverage</u>	<u>Weight</u>
8361	4' X 100'	400 sq. ft.	153 lbs.
8454	5' X 50'	250 sq. ft.	58 lbs.
8455	5' X 100'	500 sq. ft.	115 lbs.
8363	6' X 100'	600 sq. ft.	228 lbs.
8357	8' X 100'	800 sq. ft.	305 lbs.
8359	10' X 100'	1,000 sq. ft.	388 lbs.

Flex Membrane International, Inc.

2670 Leisz's Bridge Road, Suite 400,
 Leesport, PA 19533
 Phone: 1-800-969-0108
 Fax: 610-916-9501

FLEX TPO MEMBRANES**.080 Thickness****.080 Thickness FLEX WHITE Reinforced TPO Membrane**

Item Code	Roll Size	Gross Coverage	Weight
8365	4' X 100'	400 sq. ft.	171 lbs.
8456	5' X 50'	250 sq. ft.	58 lbs.
8439	5' X 100'	500 sq. ft.	205 lbs.
8367	6' X 100'	600 sq. ft.	256 lbs.
8369	8' X 100'	800 sq. ft.	342 lbs.
8371	10' X 100'	1,000 sq. ft.	442 lbs.
8374	12' X 100'	1,200 sq. ft.	511 lbs.

.080 Thickness FLEX GRAY Reinforced TPO Membrane

Item Code	Roll Size	Gross Coverage	Weight
8366	4' X 100'	400 sq. ft.	171 lbs.
8457	5' X 50'	250 sq. ft.	58 lbs.
8458	5' X 100'	500 sq. ft.	115 lbs.
8368	6' X 100'	600 sq. ft.	256 lbs.
8370	8' X 100'	800 sq. ft.	342 lbs.
8373	10' X 100'	1,000 sq. ft.	442 lbs.

FLEX TPO MEMBRANES**FLEECE-BACKED****.045 Thickness FLEX WHITE FLEECE-BACKED TPO Membrane**

Item Code	Roll Size	Gross Coverage	Weight
8375	6' X 50'	300 sq. ft.	191 lbs.
8376	12' X 50'	600 sq. ft.	191 lbs.
8377	12' X 100'	1,200 sq. ft.	353 lbs.

.060 Thickness FLEX WHITE FLEECE-BACKED TPO Membrane

Item Code	Roll Size	Gross Coverage	Weight
8379	6' X 50'	300 sq. ft.	242 lbs.
8380	12' X 50'	600 sq. ft.	242 lbs.
8381	12' X 100'	1,200 sq. ft.	453 lbs.

Flex Membrane International, Inc.

2670 Leisz's Bridge Road, Suite 400,

Leesport, PA 19533

Phone: 1-800-969-0108

Fax: 610-916-9501

FLEX TPO SELF ADHERED MEMBRANES**.045 Thickness FLEX WHITE****SELF-ADHERED REINFORCED TPO Membrane**

<u>Item Code</u>	<u>Roll Size</u>	<u>Gross Coverage</u>	<u>Weight</u>
8417	5' X 50'	250 sq. ft.	91 lbs.
8413	5' X 100'	500 sq. ft.	182 lbs.
8415	10' X 100'	1,000 sq.ft.	363 lbs.

.060 Thickness FLEX WHITE**SELF-ADHERED REINFORCED TPO Membrane**

<u>Item Code</u>	<u>Roll Size</u>	<u>Gross Coverage</u>	<u>Weight</u>
8419	5' X 50'	250 sq. ft.	111 lbs.
8414	5' X 100'	500 sq. ft.	221 lbs.
8416	10' X 100'	1,000 sq.ft.	441 lbs.

FLEX TPO FLASHING

<u>Item Code</u>	<u>Description</u>	<u>Packaging</u>	<u>Weight</u>
8422	.060 Non-Reinforced White (12" x 50')	1/Ctn	18 lbs.
8306	.060 Non-Reinforced White (24" x 50')	1/Ctn	34 lbs.
8385	.060 Non-Reinforced Gray (12", 24" x 50')	1/Ctn	18/34 lbs.
8386	.060 Non-Reinforced Tan (12", 24" x 50')	1/Ctn	18/34 lbs.

Flex Membrane International, Inc.

2670 Leisch's Bridge Road, Suite 400,

Leesport, PA 19533

Phone: 1-800-969-0108

Fax: 610-916-9501

FLEX TPO ACCESSORIES

Item Code	Description	Packaging
8328	.045 Reinforced White 6" x 100'	3 / Ctn
8388	.045 Reinforced Gray 6" x 100'	3 / Ctn
8389	.045 Reinforced Tan 6" x 100'	3 / Ctn
8309	White TPO Inside/Outside Corners	12 / Ctn
8390	Gray TPO Inside/Outside Corners	12 / Ctn
8378	Tan TPO Inside/Outside Corners	12 / Ctn
8394	White TPO Molded Pipe Flashing	8 / Ctn
8395	Gray TPO Molded Pipe Flashing	8 / Ctn
8396	Tan TPO Molded Pipe Flashing	8 / Ctn
8399	White TPO Metal 4' x 10'	25 Sheets / Skid
8397	Gray TPO Metal 4' x 10'	25 Sheets / Skid
8398	Tan TPO Metal 4' x 10'	25 Sheets / Skid
8322	30" X 50' TPO Walkway Rolls – Gray / Tan	Each
8323	30" X 50' TPO Walkway Rolls - White	Each
8401	White/Gray TPO PS Coverstrip 6" x 100'	2 / Ctn
8402	Tan TPO PS Coverstrip 6" x 100'	2 / Ctn
8423	TPO RUSS 10" x 100'	1 / Ctn
8403	TPO Extension Legs	10 / Ctn
8329	White / Gray T-Joint	100 / Ctn
8327	Molded Sealant Pocket White / Gray	5 / Ctn
8406	Molded Sealant Pocket Tan	5 / Ctn
8407	White TPO Split Pipe Boot 1 inch	8 / Ctn
8408	White TPO Split Pipe Boot 2 inch	8 / Ctn
8310	White TPO Split Pipe Boot 3 inch	8 / Ctn
8409	White TPO Split Pipe Boot 4 inch	8 / Ctn
8411	White TPO Split Pipe Boot 5 inch	8 / Ctn
8311	White TPO Split Pipe Boot 6 inch	8 / Ctn
8412	White TPO Prefab Corner 7 inch	10 / Ctn

Flex Membrane International, Inc.

2670 Leisch's Bridge Road, Suite 400,
 Leesport, PA 19533
 Phone: 1-800-969-0108
 Fax: 610-916-9501

FLEX TPO ACCESSORIES

Item Code	Name	Description
8010	BAK Rion Hand Welder	Hot Air Hand Welder
8011	BAK Laron Auto Welder with Tool Box	Auto Hot Air Welder
5007	Pressure Roller	Silicon Hand Roller
6014	Seam Probe	Hand Held Seam Probe
6025	Flex Stand Up Seam Probe	Stand Up Seam Probe
8400	Green Guard PB6W Fan Fold 4' X 5' - 3/8" (200 sq.ft./bundle)	Roof Recovery Board
8700	Flex ISO Insulation	Call 1-800-969-0108
8110	Flex DensDeck	Call 1-800-969-0108

FLEX TPO ADHESIVES AND CLEANERS

Item Code	Description	Packaging
8421	TPO Primer (used with TPO PS Coverstrip)	6 - 1 gal/Ctn
8321	TPO Bonding Adhesive (5 Gal)	5 Gal Pails
8320	Clear TPO Cut-Edge Sealant (16 oz. Bottles)	8 Bottles/Ctn
8393	Sealant Pocket Filler – PT304	24 Tubes/Ctn
8319	Weathered Membrane Cleaner	5 Gal Pails
8330	Weathered Membrane Cleaner	2 - 1 gallon
8326	Thermoplastic Pourable Sealer	2/Ctn

FLEX RHINO BOND TOOL AND PLATES

Item Code	Description	Packaging
6045	Flex RhinoBond TPO Plate	500/box
6044	Flex RhinoBond Tool (w/ 6 magnets)	Each

Flex Membrane International, Inc.

2670 Leisz's Bridge Road, Suite 400,

Leesport, PA 19533

Phone: 1-800-969-0108

Fax: 610-916-9501

FLEX OLYBOND PRODUCTS

Item Code	Name	Packaging
6055	Flex Olybond 500 (2 Part)	5 Gallons/Box
6056	Flex Olybond 500 Green (2 Part)	5 Gallons/Box
6057	Flex Olybond 500 Spot Shot	4 Sets per carton
6058	Flex Olybond 500 Spot Shot Green	4 Sets per carton
6059	Flex Olybond Pace Cart (for 500)	
6062	Pace Cart Mix Tips	20 per box
6060	Flex Olybond 500 Spot Shot Standup Gun	
6061	Flex Olybond 500 Spot Shot Power Kit	

FLEX MEMBRANE PLATES, INSULATION PLATES, TERMINATION BARS AND MASONRY ANCHORS

Item Code	Product	Unit
6006	2" Barbed Steel Membrane Plate	1,000/box
6030	2 3/8" XHD Membrane Plate	1,000/box
5049	2 3/4" Super XHD Membrane Plate	500/box
6013	3" Steel Insulation Plate	1,000/box
6021	3" Lite Deck Insulation Plate	500/box
6022	3" GYPTEC Insulation Plate	1,000/box
6023	2" GYPTEC Seam Plate	1,000/box
6015	Flat Termination Bar	50 pcs.
6024	Flat Termination Bar 1/8"	50 pcs.
6009	Lip Termination Bar	50 pcs.
5039	1/4" X 1 1/4" Masonry Anchor	1,000/box
5048	1/4" X 1 1/2" Masonry Anchor	1,000/box
5038	1/4" X 9/16" Diameter Neoprene Metal Back Washers	1,000/box
5079	3" Accu Trac Insulation Plate (Flat Bottom)	1,000/box

Flex Membrane International, Inc.

2670 Leiszcz's Bridge Road, Suite 400,

Leesport, PA 19533

Phone: 1-800-969-0108

Fax: 610-916-9501

FLEX TPO FASTENERS: STANDARD STEEL/WOOD DECK #12

Item Code	Description	Packaging
5011	1 5/8" Fastener	1,000/box
5012	2 1/4" Fastener	1,000/box
5013	2 7/8" Fastener	1,000/box
5014	3 1/4" Fastener	1,000/box
5015	3 3/4" Fastener	1,000/box
5016	4 1/2" Fastener	1,000/box
5017	5" Fastener	1,000/box
5018	6" Fastener	1,000/box
5019	7" Fastener	1,000/box
5020	8" Fastener	1,000/box

FLEX TPO FASTENERS: HEAVY DUTY ALL PURPOSE #14

Item Code	Description	Packaging
5024	1 1/4" Fastener	1,000/box
5025	1 3/4" Fastener	1,000/box
5026	2" Fastener	1,000/box
5027	3" Fastener	1,000/box
5028	4" Fastener	1,000/box
5041	5" Fastener	500/box
5029	6" Fastener	500/box
5031	7" Fastener	500/box
5032	8" Fastener	500/box
5021	9" Fastener	500/box
5022	10" Fastener	500/box
5023	11" Fastener	500/box
5035	12" Fastener	250/box
5036	13" Fastener	250/box

Flex Membrane International, Inc.

2670 Leisz's Bridge Road, Suite 400,

Leesport, PA 19533

Phone: 1-800-969-0108

Fax: 610-916-9501

FLEX TPO FASTENERS: HEAVY DUTY MEMBRANE #15

Item Code	Description	Packaging
6031	2" Fastener	1,000/box
6032	3" Fastener	1,000/box
6033	4" Fastener	1,000/box
6034	5" Fastener	500/box
6035	6" Fastener	500/box
6036	7" Fastener	500/box
6037	8" Fastener	500/box
6038	9" Fastener	500/box
6039	10" Fastener	500/box
6040	11" Fastener	500/box
6041	12" Fastener	500/box
6042	14" Fastener	250/box
6043	16" Fastener	250/box

**FLEX TPO FASTENERS:
SUPER EXTRA HEAVY DUTY MEMBRANE #21**

Item Code	Description	Packaging
5050	2" Fastener	500/bucket
5051	3" Fastener	500/bucket
5052	4" Fastener	500/bucket
5053	5" Fastener	500/bucket
5054	6" Fastener	500/bucket
5055	7" Fastener	250/bucket
5056	8" Fastener	250/bucket
5058	10" Fastener	250/bucket
5059	12" Fastener	250/bucket

Flex Membrane International, Inc.

2670 Leisz's Bridge Road, Suite 400,

Leesport, PA 19533

Phone: 1-800-969-0108

Fax: 610-916-9501

FLEX TPO FASTENERS: CD-10, FOR USE IN CONCRETE DECKS

Item Code	Description	Packaging
5044	CD-10 2" Fastener	500/box
5082	CD-10 2 1/2" Fastener	500/box
5046	CD-10 3" Fastener	500/box
5083	CD-10 3 1/2" Fastener	500/box
5047	CD-10 4" Fastener	500/box
5084	CD-10 4 1/2" Fastener	500/box
5057	CD-10 5" Fastener	500/box
5085	CD-10 5 1/2" Fastener	500/box
5086	CD-10 6" Fastener	500/box
5087	CD-10 7" Fastener	500/box
5088	CD-10 8" Fastener	500/box
5090	CD-10 9" Fastener	250/box
5091	CD-10 10" Fastener	250/box
5092	CD-10 11" Fastener	250/box
5093	CD-10 12" Fastener	250/box

Application:

A 7/32" hole must be predrilled, minimum fastener embedment 1" into concrete.

Predrilled hole must be 1/2" deeper than fastener embedment.

**CR Base Sheet & Olylock Fastener
(For Base Sheet Attachment)**

Item Code	Description	Packaging
5037	1.2" Coated Base Sheet Assembled	1,000/box
5010	1.75" Coated Base Sheet Assembled	500/box
6048	1.4" Flex Olylock Fastener	500/box
6059	1.8" Flex Olylock Fastener	500/box
6051	2.8" Flex Olylock Fastener	500/box
6052	3.8" Flex Olylock Fastener	500/box
6053	4.8" Flex Olylock Fastener	500/box
6054	Flex Olylock Installation Tool	1 each

Flex Membrane International, Inc.

2670 Leiscz's Bridge Road, Suite 400,
 Leesport, PA 19533
 Phone: 1-800-969-0108
 Fax: 610-916-9501

GYPTEC 1" Head Without Wire for use in Tectum, Gypsum, Lightweight Concrete

Item Code	Description	Packaging
5061	GYPTEC 2 1/2" Fastener	500/box
5062	GYPTEC 3" Fastener	500/box
5063	GYPTEC 3 1/2" Fastener	500/box
5064	GYPTEC 4" Fastener	500/box
5065	GYPTEC 4 1/2" Fastener	500/box
5066	GYPTEC 5" Fastener	500/box
5067	GYPTEC 5 1/2" Fastener	500/box
5068	GYPTEC 6" Fastener	500/box
5069	GYPTEC 6 1/2" Fastener	500/box
5070	GYPTEC 7" Fastener	500/box
5071	GYPTEC 7 1/2" Fastener	500/box
5072	GYPTEC 8" Fastener	250/box
5073	GYPTEC 8 1/2" Fastener	250/box
5074	GYPTEC 9" Fastener	250/box
5075	GYPTEC 9 1/2" Fastener	250/box
5076	GYPTEC 10" Fastener	250/box

PURLIN FASTENERS

Item Code	Description	Packaging
6026	3-3/4" Purlin Fastener	500/box
6027	4-3/4" Purlin Fastener	500/box
6011	5-3/4" Purlin Fastener	500/box
6028	7" Purlin Fastener	500/box
6029	8" Purlin Fastener	500/box

The Purlin Fastener is designed to self drill standard purlins (18-12 gauge).

The Purlin Fastener has 2/4" drill point which allows the screw to quickly drill through the purlin before the threads engage. Therefore, the effective length of the Purlin Fastener is 3/4" less than the actual length. For insulation attachment, use the standard 3" insulation plate.

Flex Membrane International, Inc.

2670 Leisch's Bridge Road, Suite 400,

Leesport, PA 19533

Phone: 1-800-969-0108

Fax: 610-916-9501

FLEX TPO PIPE GUARDS

<u>Item Code</u>	<u>Description</u>	<u>Packaging</u>
7040	Flex Pipe Guards Mini	20 per box
7041	Flex Pipe Guards Small	20 per box
7042	Flex Pipe Guards Large	10 per box

FLEX TPO RETROFIT DRAIN SYSTEMS

<u>Item Code</u>	<u>Description</u>	<u>Packaging</u>
8030	3" Clamping Ring Model	18" X 18"
8031	4" Clamping Ring Model	18" X 18"
8032	5" Clamping Ring Model	18" X 18"
8033	6" Clamping Ring Model	18" X 18"

Accu Trac Insulation Tool

<u>Item Code</u>	<u>Description</u>	<u>Packaging</u>
5080	Accu Trac Tool	1 per box
6054	Flex Olylock Installation Tool	1 each



For additional information:

Call Flex Roofing Systems
1-800-969-0108

or visit our website
www.FlexRoofingSystems.com

There you can search "Technical Documents" for CSI Formatted Specifications, additional Detail Drawings and other important information.

Flex Membrane International, Inc.

2670 Leisch's Bridge Road, Suite 400,
Leesport, PA 19533
Phone: 1-800-969-0108
Fax: 610-916-9501

Flex[®]

Roofing Systems

Flex Membrane International, Inc.

2670 Leisz's Bridge Road, Suite 400

Leesport, PA 19533

Phone: 1-800-969-0108

Fax: 610-916-9501

FlexRoofingSystems.com

