

[Natural Resources Canada](#)

[Home](#) → [Energy](#) → [Energy Efficiency](#) → [Energy-efficient homes](#) → [Homeowners](#) → [How can I make my home more energy-efficient?](#)
→ [Keeping the Heat In](#) → Keeping The Heat In - Chapter 6: Basement insulation

Keeping The Heat In - Chapter 6: Basement insulation

Basements can account for about 20 percent of a home's total heat loss. This is due to the large, uninsulated surface area both above and below grade level. Contrary to popular opinion, earth is a poor insulator. There is also a lot of air leakage through basement windows and penetrations (including cracks in these areas) and at the top of the foundation wall (sill area). Many basements have little or no insulation, so this means there is much potential for improvement. Insulating can often be tied in with other repairs or renovation work such as waterproofing, radon remediation or finishing the basement.

Chapter Summary

[6.1 INSULATING THE BASEMENT FROM THE OUTSIDE](#)

[6.2 INSULATING THE BASEMENT FROM THE INSIDE](#)

[6.3 CRAWL SPACES](#)

[6.4 OPEN FOUNDATIONS](#)

[6.5 CONCRETE SLAB ON GRADE](#)

Types of basement construction

The most common type of construction is the full foundation basement, with mainly below grade foundation walls supporting the house structure. Many houses have been built with partial depth foundation walls that create a crawl space under the house. Some older homes, cottages or mobile homes are built up on posts and piers, leaving the space below the house open or walled off. Other houses are built on a slab-on-grade where there is no basement or crawl space at all.

i) Concrete foundations

Poured or concrete block foundations have been built since the 1920s, usually with parging, waterproofing and drain tiles on the exterior. However, anything more than 20 years old may need some repair. This type of foundation can be insulated from the outside or inside if no serious water or structural problems exist.

ii) New houses or new foundations under older houses

If the house is new or it has been raised to accommodate a new basement, allow about a year of drying out time before insulating or renovating. As concrete contains large amounts of moisture, it is best to let it dry before insulating and finishing unless the renovation method to be used can handle this entrained moisture.

iii) Older rubble, brick or stone foundations

Older foundations are often uneven and can vary in depth and thickness. These foundations were rarely damp-proofed; some have an interior drainage path and all have a high mortar content, which can absorb water from the soil. They are best insulated from the outside, but some interior insulating is possible. Always obtain expert advice before

proceeding on remediation.

iv) Other types of foundations

Many newer homes are built with preserved wood foundations. They are damp-proofed and are generally fully insulated.

Basement assessment

Before planning the job, assess the status of your basement. Here are some of the problems to look for:

i) Water leaks

Major water leaks, such as persistent leaks and flooding in the spring and when it rains, must be corrected. Often the solution requires excavating, damp-proofing or waterproofing the basement, adding a drainage system and insulating from the exterior.

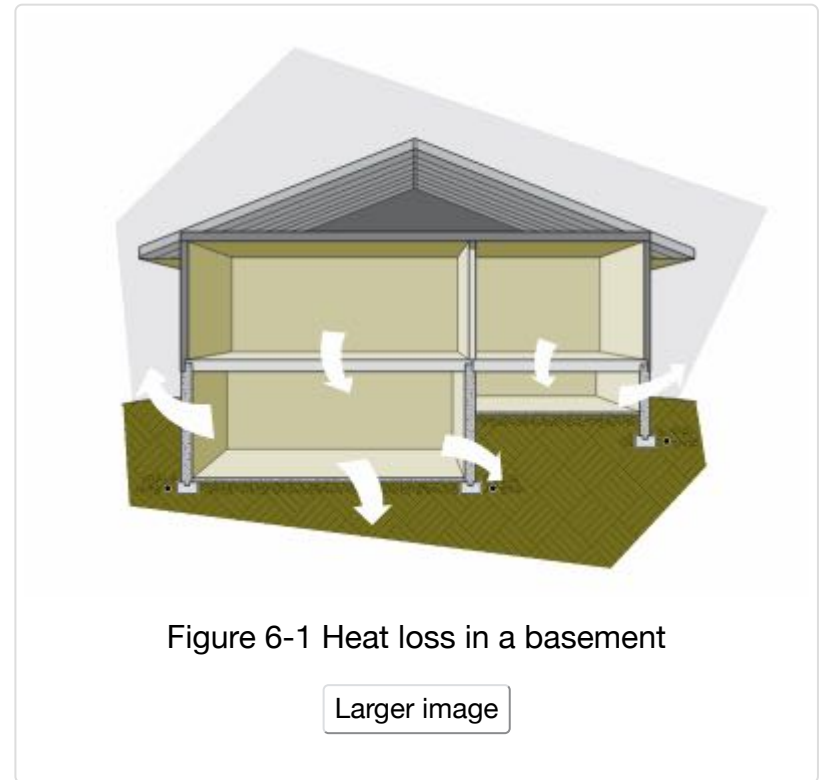

Figure 6-1 Heat loss in a basement

[Larger image](#)

Minor water leaks can sometimes be corrected by directing water away from the foundation by sloping the grade, aiming downspouts away from the house and patching the foundation on the interior.

Correct any problems with sump pumps or sewer backup before beginning the insulation job.

ii) Dampness

Symptoms of dampness on foundations and finishes include staining or mould growth, blistering and peeling paint, efflorescence (a whitish mineral deposit on the surface), spalling (deterioration of the surface) as well as a musty smell. Minor dampness may be corrected from the interior; more serious problems should be corrected from the outside. Condensation can also form on the foundation walls in the summer when the air is very humid and the foundation is cool.

Checking for dampness

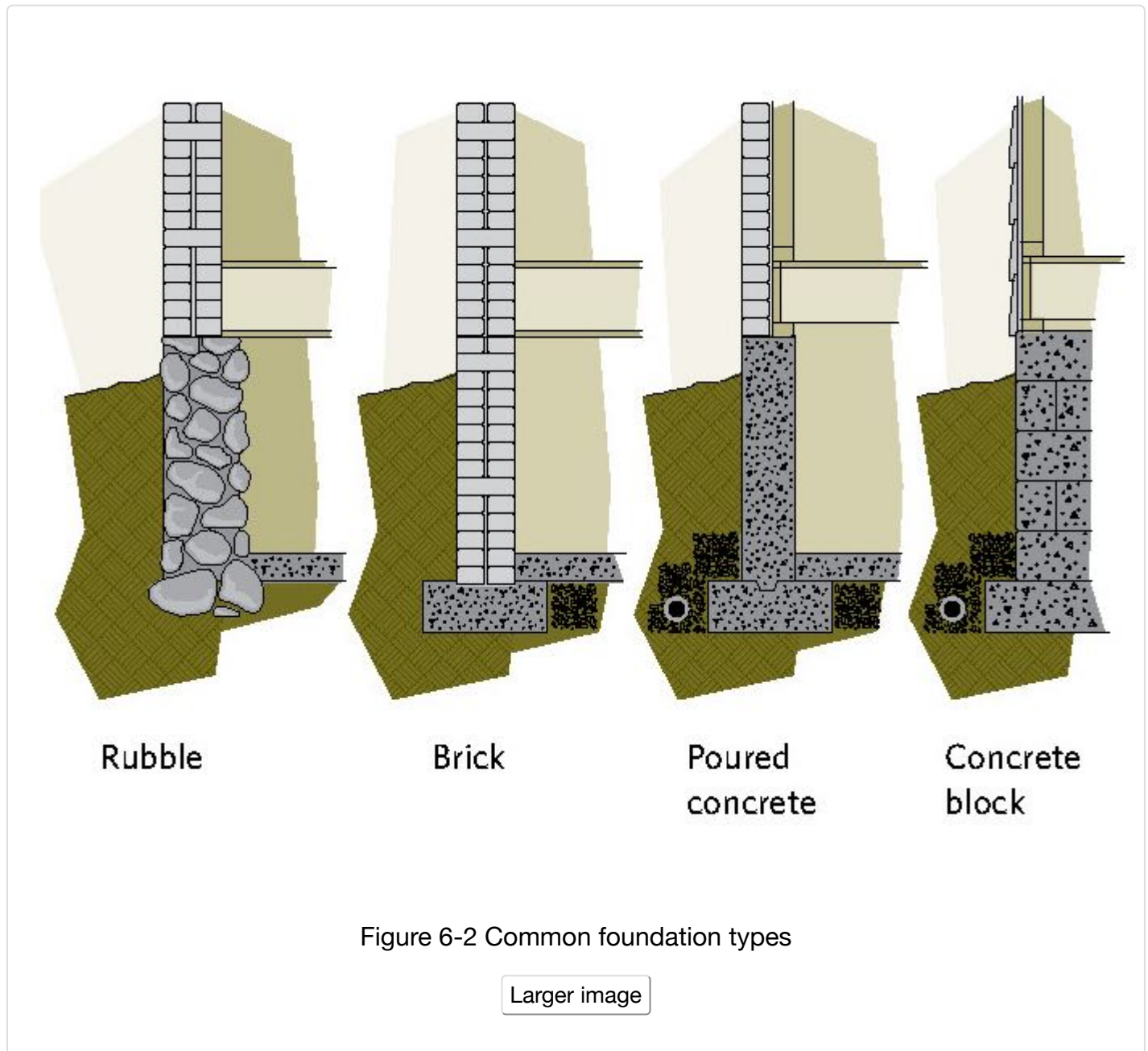

If the foundation walls, slabs and earth floors appear dry yet the space seems damp, this might indicate that moisture is wicking through the foundations and evaporating faster than it can accumulate.

To test for this, cut a sheet of plastic about 1 m (40 in.) square and tape it to the concrete walls and slab. For earth floors, hold down the edges with sand or sticks. After a day or two, check the plastic. If condensation formed on the top of it, this indicates high interior moisture levels. (See details in Section 2.4, Control of moisture flow and Section 9.4, Ventilation and combustion air.)

Carefully remove the plastic and note any condensation on the bottom of the plastic or wetting of the concrete or soil. Condensation formed under the plastic indicates moisture movement from the ground into the home as well as the possibility of radon emissions.

To reduce the movement of moisture into the home from the foundations, apply a moisture barrier (see Section 6.3, Crawl spaces) or have the interior or exterior concrete sealed or waterproofed.

iii) Cracks

If the basement has an active crack (i.e. one that gets bigger or smaller), seek professional help to determine if the situation requires structural repairs.

iv) Radon

Radon may be present in all homes, with and without humidity and moisture problems (see Section 1.4, Health and safety considerations, for more information).

Insulate inside or outside?

Insulating on the outside is best, but it is often necessary to insulate from the inside for economical and practical reasons. Sometimes a combination of approaches is required. Examine the advantages of each approach carefully.

i) Insulating inside

This may involve installing rigid insulation board and drywall, a wood-frame wall and insulation or other combinations of insulation. Your choice of method will depend on a number of factors, including whether there are moisture issues, the need to account for moisture and air/vapour barriers, how you plan to use the space and, finally, cost.

Advantages of inside insulation

- It can be incorporated into a plan to finish the basement.

- The work can be done at any time of the year and can be done one section at a time. Often all or part can be a do-it-yourself job.
- It is often easier and cheaper to insulate the full wall and achieve high insulating values.
- The landscaping and driveway will not be disturbed.

Disadvantages of inside insulation

- Do not insulate a basement with moisture problems from the inside (leaks, dampness, efflorescence and blistering paint). If you must, take corrective measures to eliminate the moisture before adding insulation or your new walls will rot.
- Adding insulation to the inside will make the foundation walls even colder. Any humid air that comes in contact with these cold walls will condense. Interior finishes hide or obscure moisture problems as they develop. This can lead to long-term mould exposure as people are less likely to fix a moisture problem if they have to remove finishing that they have erected.
- Obstructions such as electrical panels, wiring, plumbing, stairs and partition walls make the work more difficult and the insulation and air barrier less effective. If part of the basement wall is already finished, this too may prove troublesome, although wall paneling may be easy to remove and re-install.

i TECHNICAL NOTE:

Some authorities have expressed concern about the possibility of frost action and structural damage when foundations are insulated from the inside. The concern is that frost will penetrate deeper down the outside of the foundation wall. Research has found that this is not a problem. Under some circumstances, such as in soils that are particularly frost-susceptible in extreme climates, there could be a problem caused by some construction techniques. Check with your local building authorities or find out if your neighbours have experienced any difficulties with frost action on their foundation.

ii) Insulating outside

This involves excavating around the foundation, waterproofing and installing insulation, as per Figure 6-3. Flashing must be attached to keep water from getting behind the insulation and a protective covering installed on exposed sections of insulation.

Advantages of outside insulation

- The outside wall tends to be more continuous and easier to insulate.
- You can effectively see and correct any moisture or structural problems (efflorescence, cracks, spalling and eroded mortar). Rubble or brick foundations and foundations with water leakage, dampness or other moisture problems should be insulated

from the outside. Repairing the foundation, parging, waterproofing and installing a drainage system can be done at the same time.

- There is no disruption in the house, no interior work disturbed and no inside space lost.
- Freeze-thaw stresses are eliminated, and frost is unlikely to penetrate down to the footings.
- The mass of the foundation is within the insulated portion of the house and will tend to even out temperature fluctuations.

Disadvantages of outside insulation

- Digging a trench around the house by hand can be difficult and risky depending on soil type and depth. It is much easier to use machinery but access could be a problem.
- Storing the dirt can be a problem.
- Excavation cannot be done in winter and can be a problem in the spring or throughout the year if the property has a high water table.
- Features such as non-removable steps, paved carports, shrubbery, trees or fences can make the work difficult.
- Rubble or brick foundations could be partially supported by the soil. Get expert advice before starting.
- It is expensive to obtain high insulation levels, and the retrofit may detract from the appearance of the house.

6.1 INSULATING THE BASEMENT FROM THE OUTSIDE

Further to the previous introduction, assess the following before beginning work:

- outside features such as buried and surface services, access and lot lines inhibiting excavation
- insulation requirements (type and thickness, height and depth) finishing details (protective coating, flashing)
- tools and equipment required (for excavating, water-sealing, insulating, etc.)

6.1.1 Special safety considerations

Refer to Section 1.4, Health and safety considerations, for general advice on safe working procedures.

For every underground service that enters your home (e.g. gas, electricity, telephone, water and sewage), find out where each is located before you begin digging. Utilities provide this service at no cost.

How to insulate outside the basement

The work may require several weeks of effort. Plan for extra time if you need to excavate, repair cracks, waterproof the exterior foundation walls and install a drainage system.

Insulating the outside of the basement includes the following steps:

i) Dig the trench

The excavation should ideally go down to the footings but never below. The trench should be wide enough to work in. It is a big job, so do not make it even bigger with an oversize trench. Digging may be done by hand or using appropriate machinery. The excavated dirt can be stored on a tarp or sheet of polyethylene at least 610 mm (24 in.) away from the excavation.

In some cases it may only be practical to install insulation to a minimum of 610 mm (24 in.) below grade, especially when the foundation walls and drainage system are in good condition. This will reduce the excavating required while still offering substantial thermal protection, and can be coupled with further interior insulating. An optional horizontal rigid insulation skirt can also be added to reduce heat loss to the surface, which can mitigate frost-related problems (see Figure 6-4).

⚠ SAFETY WARNING:

In particular, follow safe trenching practices to avoid accidental burial and trench collapse. Protect the trench from running water and the elements, and ensure that people and animals cannot fall in. Some soils are not stable and may require bracing to prevent collapse. If you are doing this yourself, consult local building authorities for advice on proper shoring and trenching practices.

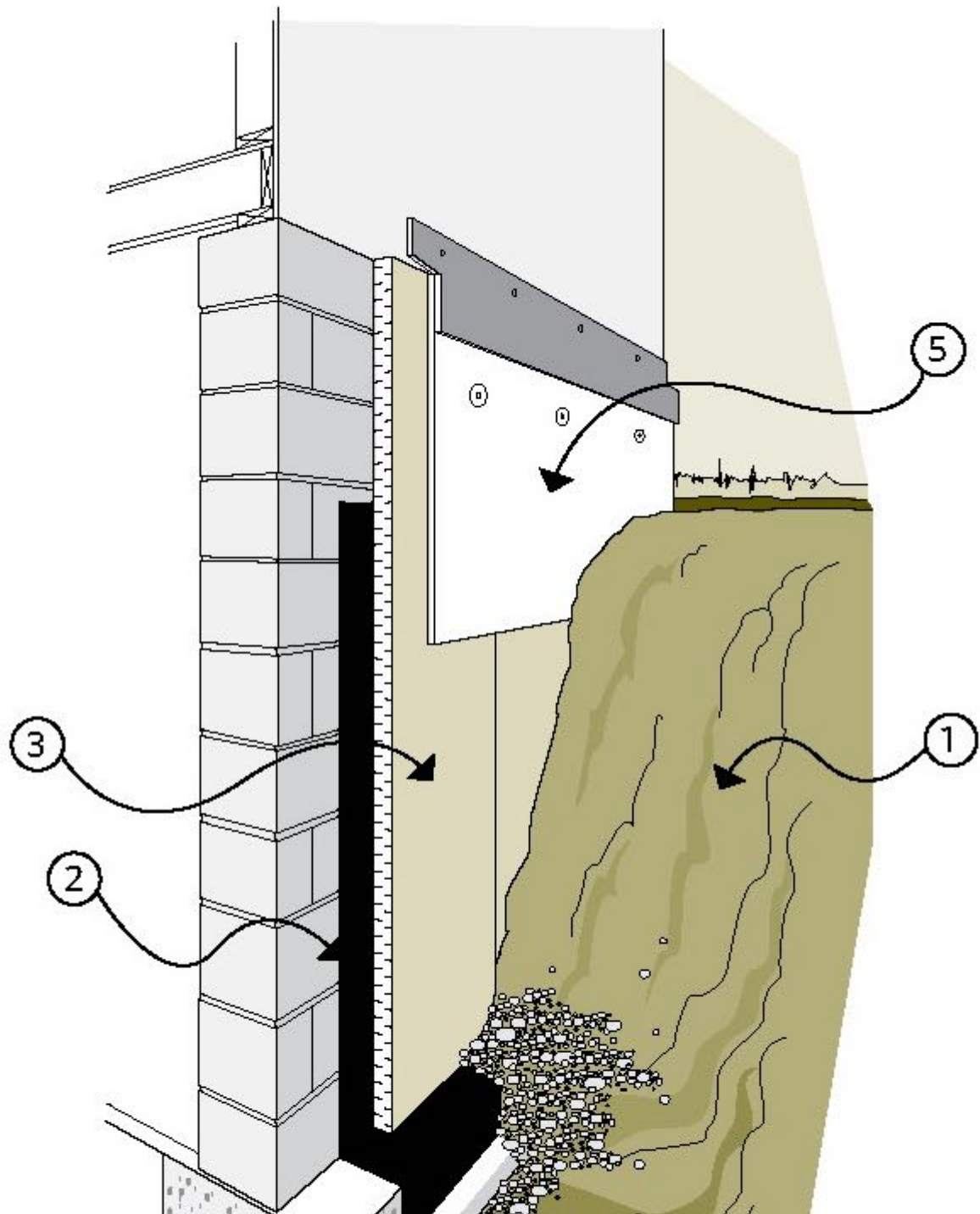

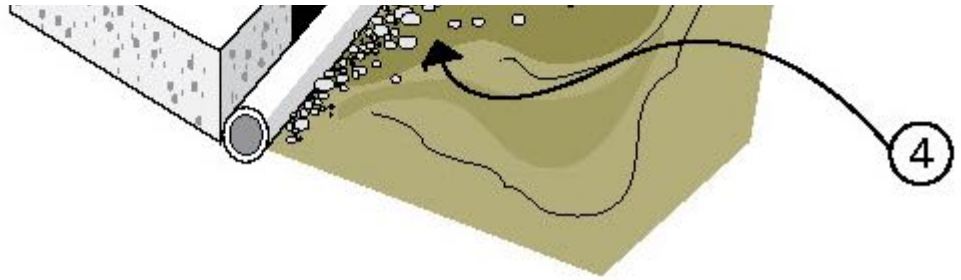

Exterior insulation involves

1. excavation
2. waterproofing
3. insulation
4. drainage system and backfill
5. protective coating and flashing

Figure 6-3 Components of exterior insulation

[Larger image](#)

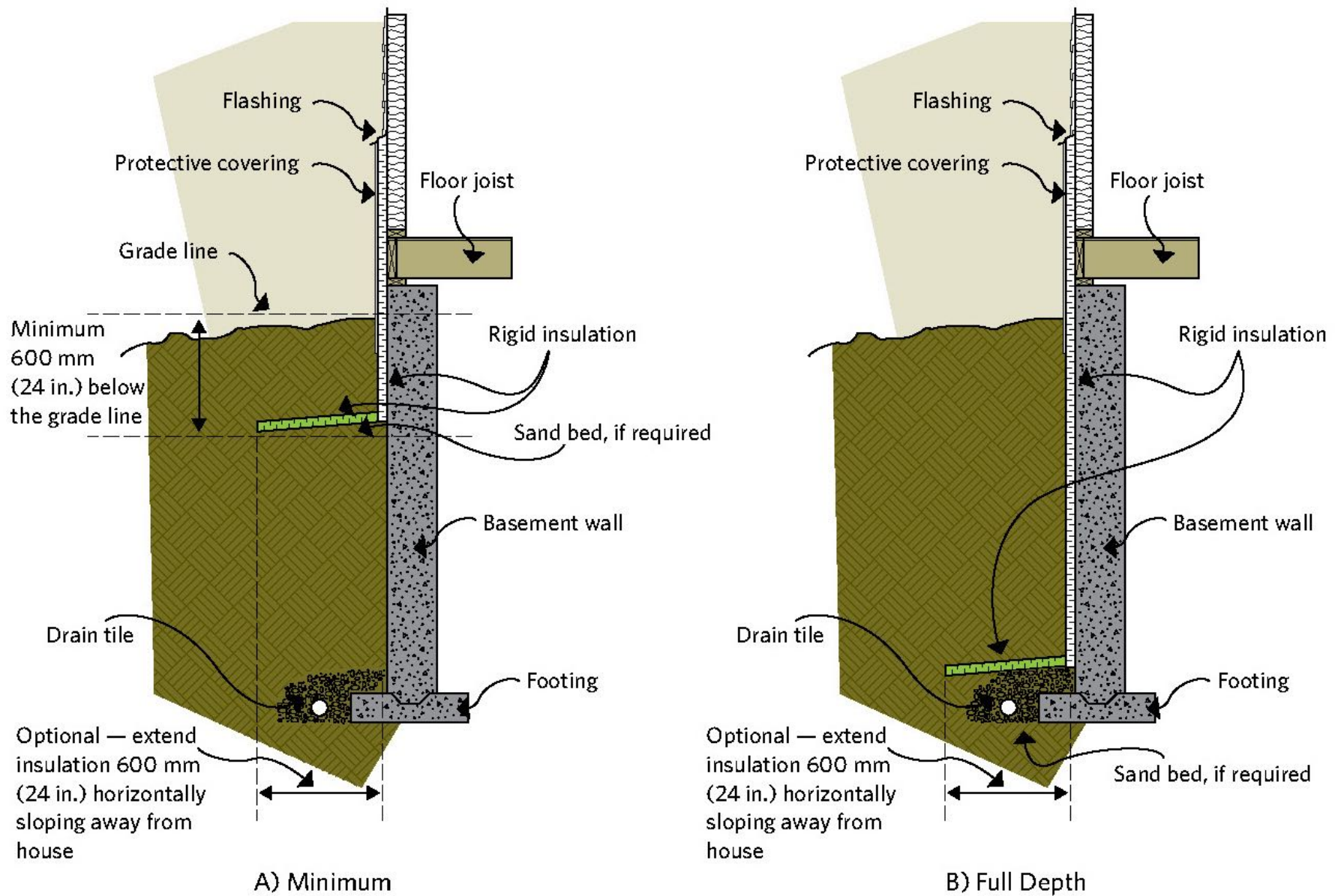

Figure 6-4 Exterior basement insulation

Larger image

ii) Prepare the surface and site

First clean the surface of the foundation with a wire brush and scraper or use a pressure-washer if you can easily remove the water. Inspect and repair any major holes, cracks or damage and then seal all penetrations. Smooth or replace deteriorated surfaces and old parging with an appropriate type of new parging. Allow repairs to dry.

Check the condition of the drainage tiles and repair as needed. Install a drainage system if one does not exist but only if it can be done properly (i.e. one that can drain to an appropriate discharge). It is best to do this task after completing work on the foundation wall. Consult a drainage systems expert before proceeding.

Have a contractor apply waterproofing material from grade level down to and over the top of the footings, and then seal all penetrations and overlaps. Sheet materials, sprays and roll-on compounds are available. Follow all manufacturers' directions.

iii) Apply the insulation

Three types of insulation are used on the exterior of basement walls: rigid mineral wool boards, high-density polystyrene (Type IV) and polyurethane/polyisocyanurate boards. (See Section 4.2, Caulking and other air sealing materials, for more information.)

Type IV polystyrene board is the material most commonly used in exterior below-grade applications (see Figure 6-3 and Figure 6-4).

Insulation with drainage capability (see Figure 6-5), such as mineral wool board, must be used only if:

- It is applied to the full depth of the foundation wall.
- There is a drainage system.
- The insulation has no horizontal seams that break the drainage path.

Measure and cut the insulation to the desired height (generally from the top of the footings to the exterior wall flashing). Start installing the insulation at one corner, overlapping at the corners and keep the insulation sheets as tight to the wall as possible (see Figure 6-6).

It may be convenient (although more expensive) to purchase a special interlocking system of grooved polystyrene boards with steel channels. These should be used in the above-grade portion only to a depth of 305 mm (12 in.). There are also special clips and fasteners for applying the rigid board to the wall; check building-supply stores.

Apply parging to rubble and brick foundations to smooth the wall after all repairs have been completed. The type and flexibility of the insulation will determine the smoothness of the parging required. The correct parging material will also act as a sacrificial surface material to help protect the mortar in the foundation wall. Waterproof the parging, insulate and then proceed as noted above.

iv) Apply the flashing

Flashing helps keep the insulation in place, prevents water from getting behind it and provides a clean, neat junction. There are two major considerations: the location of the flashing, which defines how far up the wall the insulation extends, and the type of flashing used.

If the siding can be partially removed or pried up, use standard Z-flashing inserted at least 50 mm (2 in.) behind the siding and building paper (i.e. behind the drainage plane). If you cannot insert flashing behind the siding (such as with brick), then either a metal J-channel must be installed prior to the insulation or a wood flashing installed after the insulation.

Flashing should accommodate the width of the insulation and protective coat. Wood flashing should be sloped with an overhang of at least 20 mm ($\frac{3}{4}$ in.) and have a drip edge on the underside.

For wood flashing or a J-channel, seal the joint between the flashing and the house with a suitable caulking.

For brick siding, keep the weep holes open that allow water to escape from behind the brick.

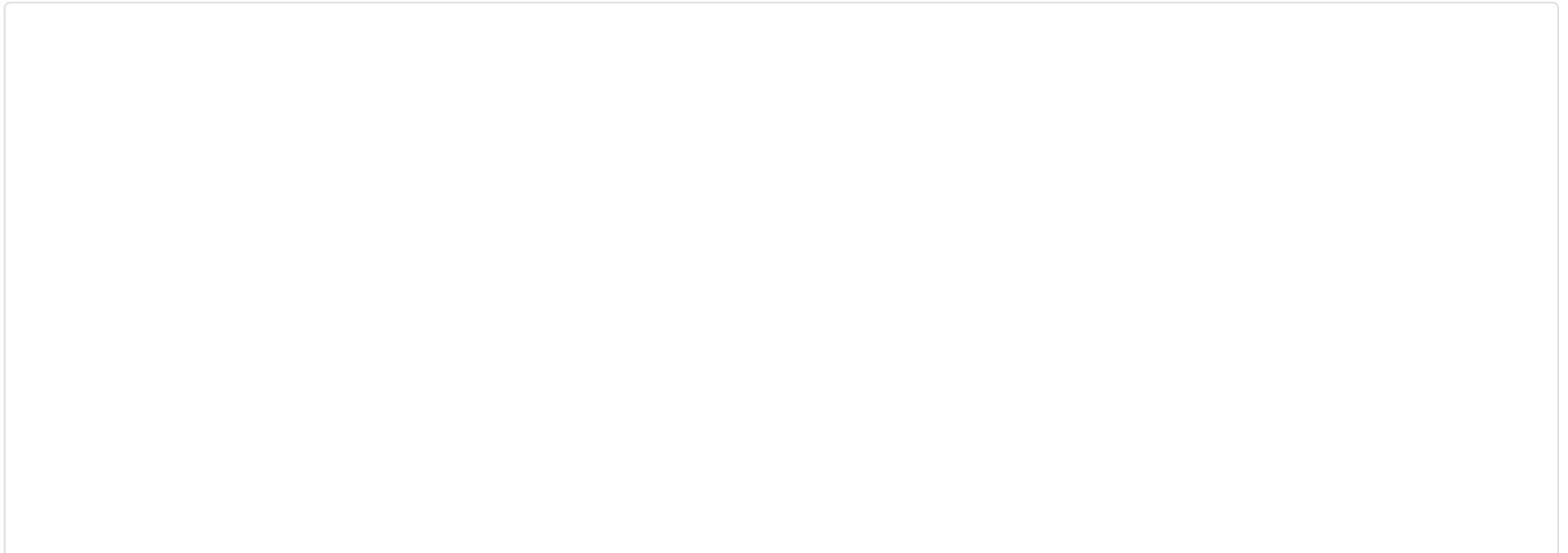

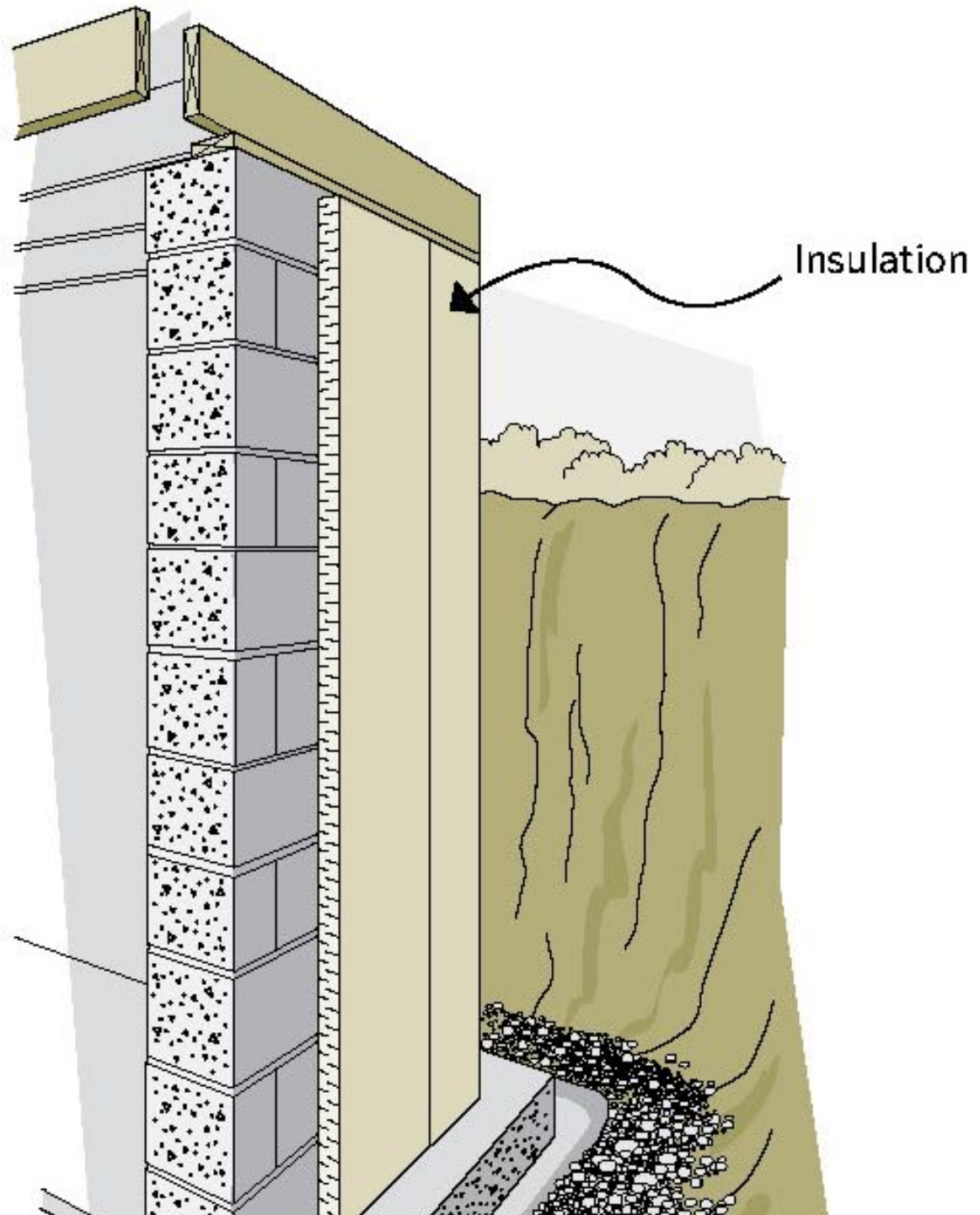

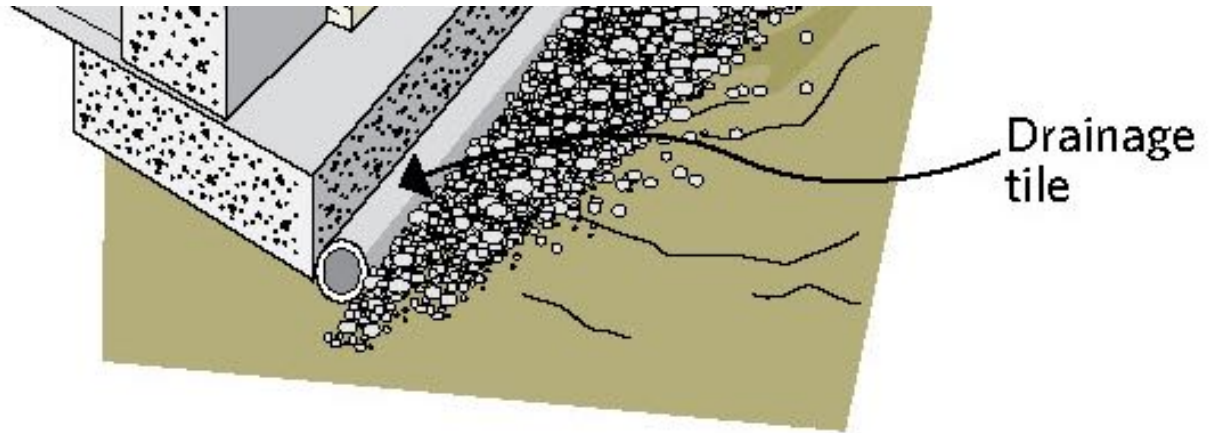

A drain tile is essential.

Figure 6-5 Draining-type insulations must be installed vertically all the way down to the footings

[Larger image](#)

i TECHNICAL NOTE:

Some experts suggest using two layers of insulation with overlapping joints. The insulation is held in place at the top edge by the flashing and by using corrosion-resistant fasteners and washers. The below-grade portion of the insulation will be held in place by the backfill, but may require some fasteners to hold it in place during the process.

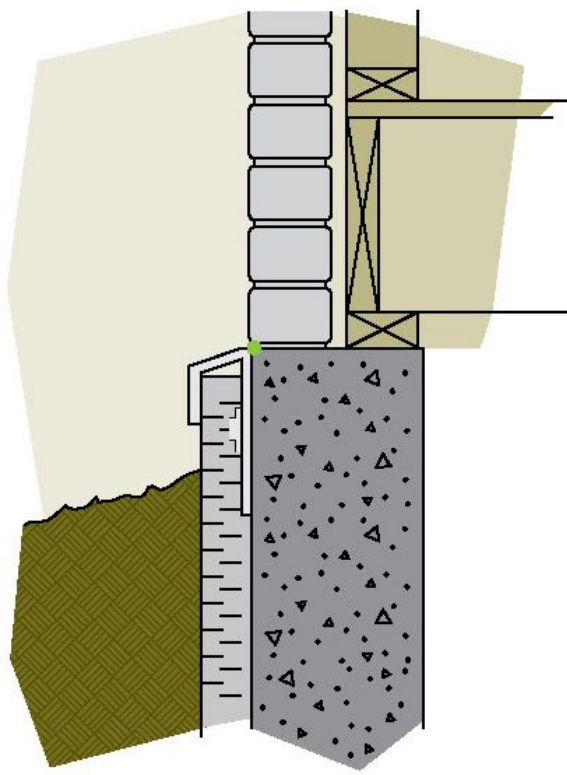

J channel

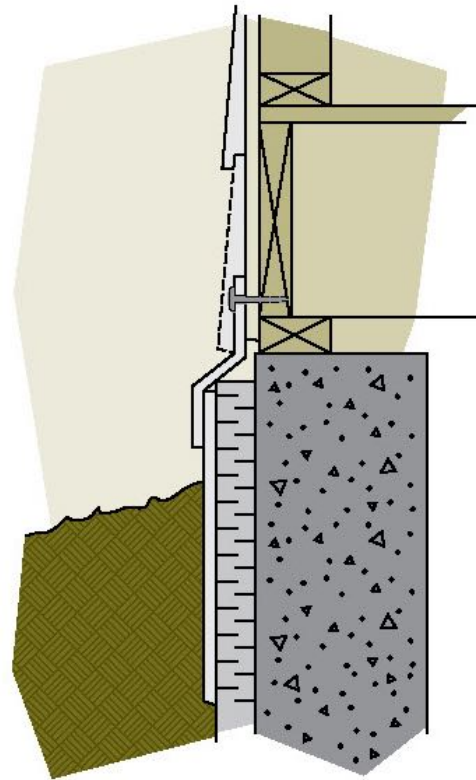

Z flashing

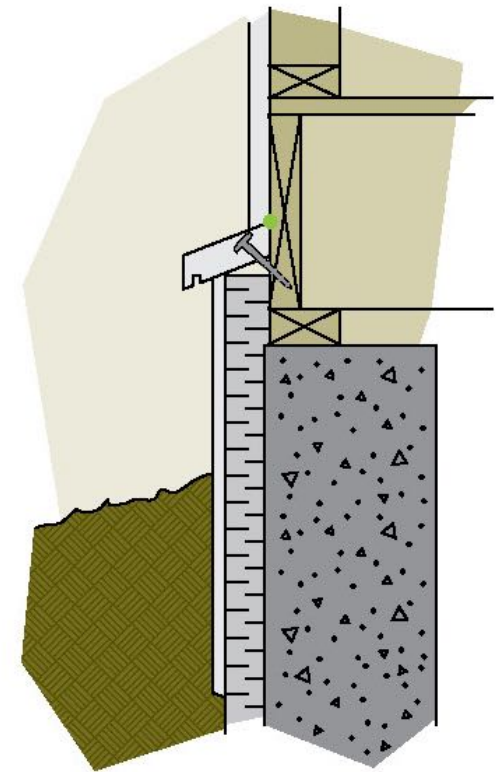

Wood flashing

Figure 6-7 Types of flashing for a foundation – First floor transition

[Larger image](#)

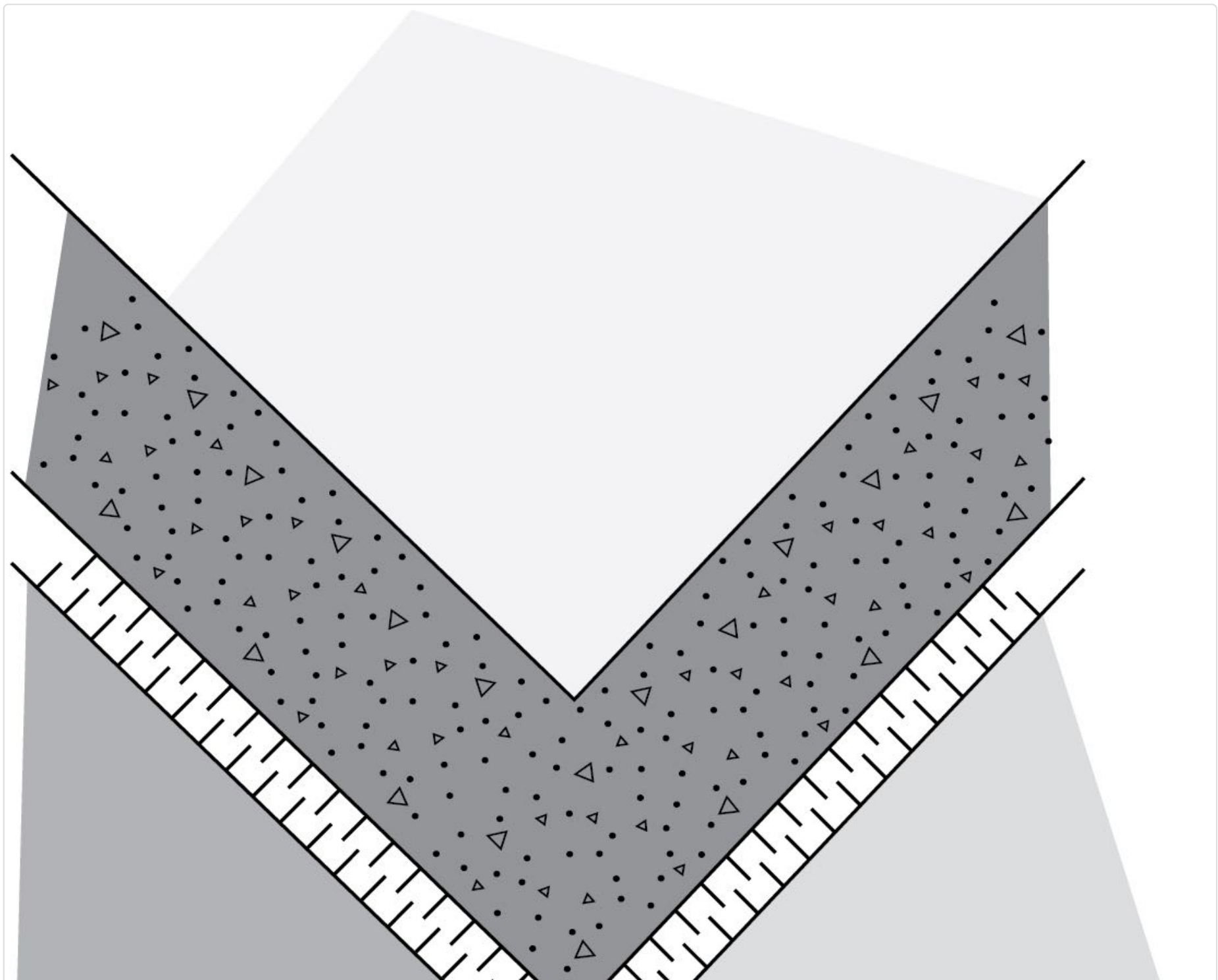

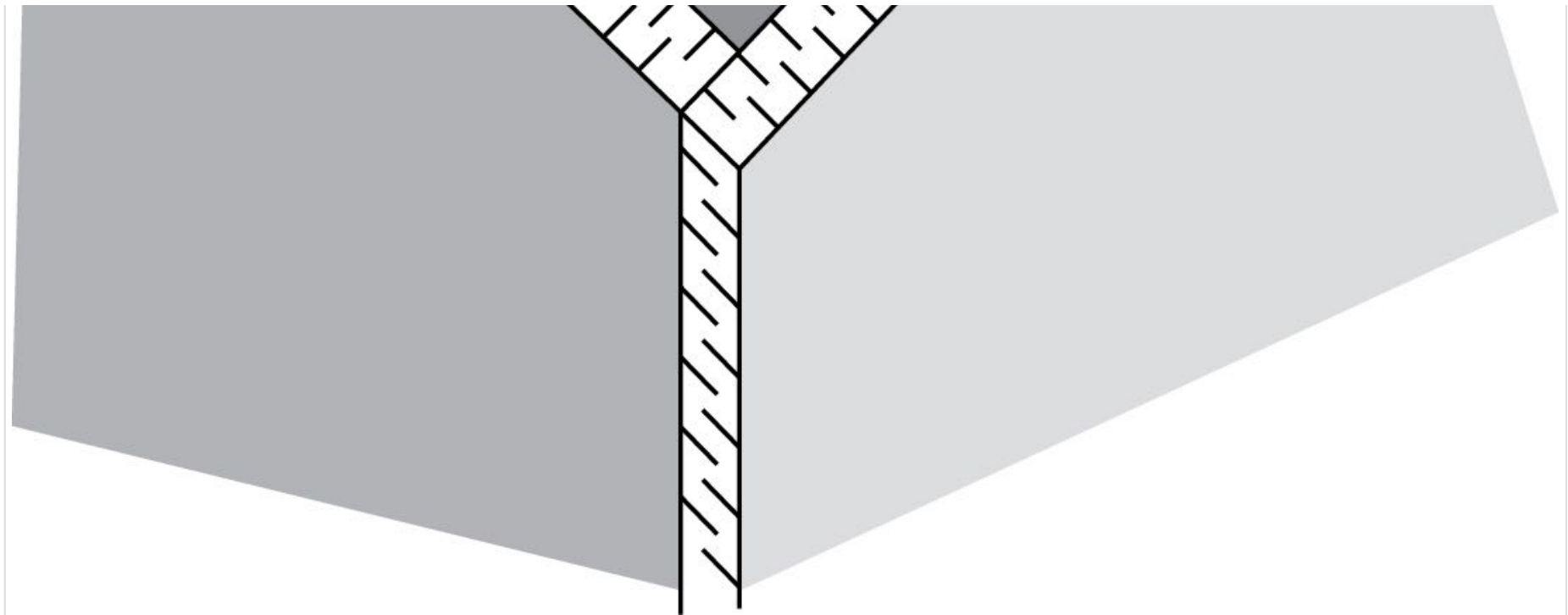

Figure 6-6 The insulation should overlap at corners

[Larger image](#)

Ideally, carry the insulation up past the header area by at least 150 mm (6 in.) as shown in Figure 6-8. This often cannot be done because of practical or aesthetic reasons. If the insulation is carried up only to the header area or lower, then air seal and insulate the header area from the interior. This is described later in this chapter.

v) Protect the exterior by covering the exposed insulation

Protect the insulation from sunlight and physical damage with a covering applied from the top of the insulation to a point about 300 mm (12 in.) below ground level.

Covering options include the following:

- expanded metal lath with cement parging
- polymer-modified pargings, which go directly on some types of insulation without metal lath – check manufacturer's literature

- pressure-treated plywood installed using stainless-steel fasteners vinyl or other siding that matches the house siding

vi) Refill the excavation

First, cover the drain tiles (i.e. the perforated plastic pipe) with 150 mm (6 in.) of clean gravel – 4 mm (1/8 in.) or larger – and a strip of filter fabric. If drainage insulation is used, the gravel should extend at least 100 mm (4 in.) up the side of the insulation.

Backfill the excavated area in stages by removing large objects from the backfill and then compacting or tamping the ground. In poor draining soils such as expansive clay, it would be better to bring in free-draining backfill. When the excavation is filled, make sure the ground slopes away from the house. Usually a slope of 10 percent (i.e. 200 mm [8 in.] for the first 2 m [6 ft.]) is provided to allow for settling. This will encourage drainage away from the insulation, as will the addition of eavestroughs and downspouts that direct excess surface water away from the foundation by at least 2 m (6 ft.).

Cover the filled excavation with any type of surface – patio stones, grass or a garden. Some additional settling may take place, so it is better to wait before undertaking any expensive treatments such as paving.

vii) Complete the finishing details

Windows can usually be finished by wrapping the insulation around the foundation to meet the window frame. Apply lath and parging on top of the insulation to the edge of the window frame. Caulk the joint between the frame and parging, and inspect it periodically to make sure it is still sealed.

Doors should be outlined with a J-channel or equivalent flashing. You may have to extend the doorsill to protect the flashing beneath the door.

Seal penetrations through the insulation and covering to prevent wind, water and vermin entry. Some penetrations (gas lines, electrical conduits) should be sealed with a compatible and flexible sealant.

viii) Insulate the exterior joist header area

If the exterior insulation does not extend above the header area by at least 150 mm (6 in.), air seal and insulate the header area from inside the basement. (See Section 6.2, Insulating the basement from the inside.)

6.1.2 Complications

Where part of the basement wall encloses a cold cellar or unheated garage, apply the insulation inside the basement, against the cold cellar or garage walls, treating them like exterior basement walls. Weatherstrip and insulate the doorway from the basement. Finally, insulate the ceiling of the cold cellar or garage. (See Section 6.4, Open foundations, for information about exposed floors.)

Extend the outside insulation around the rest of the basement by at least 610 mm (24 in.) beyond the inside wall junction to minimize heat loss at these points. (For information about insulating a cold cellar, see Section 6.2, Insulating the basement from the inside).

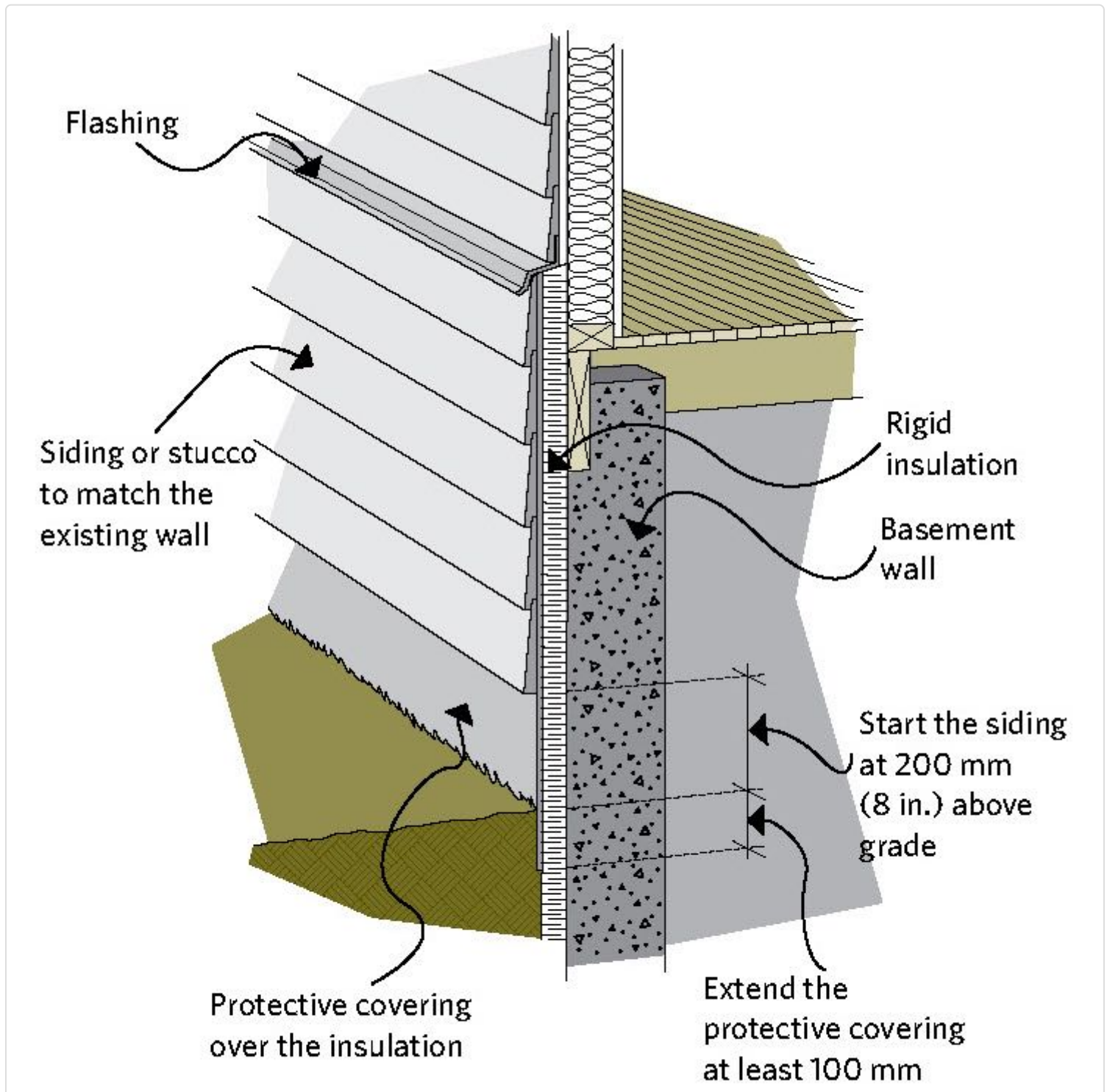

If a concrete porch is butted against a basement wall, a paved driveway or some other obstruction, the insulation should switch to the inside around these obstacles. Allow

at least 610 mm (24 in.) of overlap to provide continuous coverage and reduce the heat loss through the thermal bridge.

(4 in.) below grade

Figure 6-8 Insulating the header area from the exterior

Larger image

6.2 INSULATING THE BASEMENT FROM THE INSIDE

Since basement type and condition will influence how you insulate, be sure to also consider the following factors:

- indications of structural problems (e.g. cracks and bulges)
- insulation requirements (e.g. type, RSI (R) value and location)
- wiring and plumbing upgrades
- finishing details

Consult your local building authorities to be sure that your proposed project will meet code requirements. Also, some regions have particular problems such as frost heave due to expansive clay soils, which you should consider before beginning work.

Common types of insulation used as interior basement insulation include batt or blanket, glass fibre loose fill, polyurethane spray and rigid plastic board.

Closed cell polyurethane spray foam, which should be applied only by a certified installer, is a high-quality insulating method for all types of walls, including uneven ones. Closed cell spray foam can also help control dampness on basement walls.

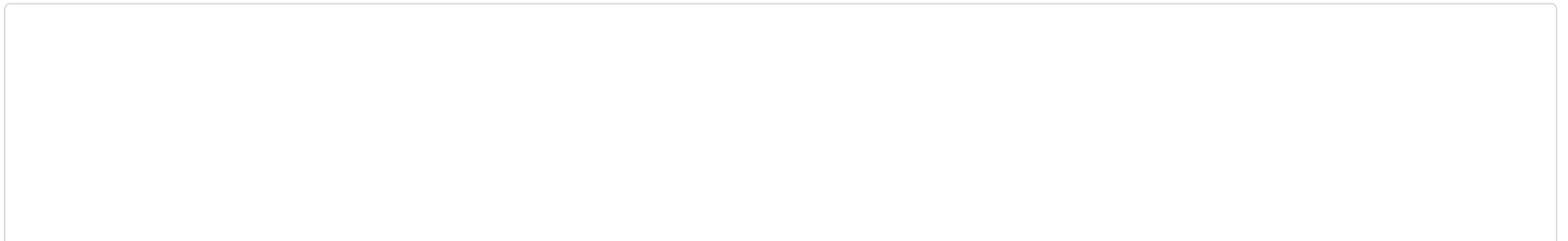

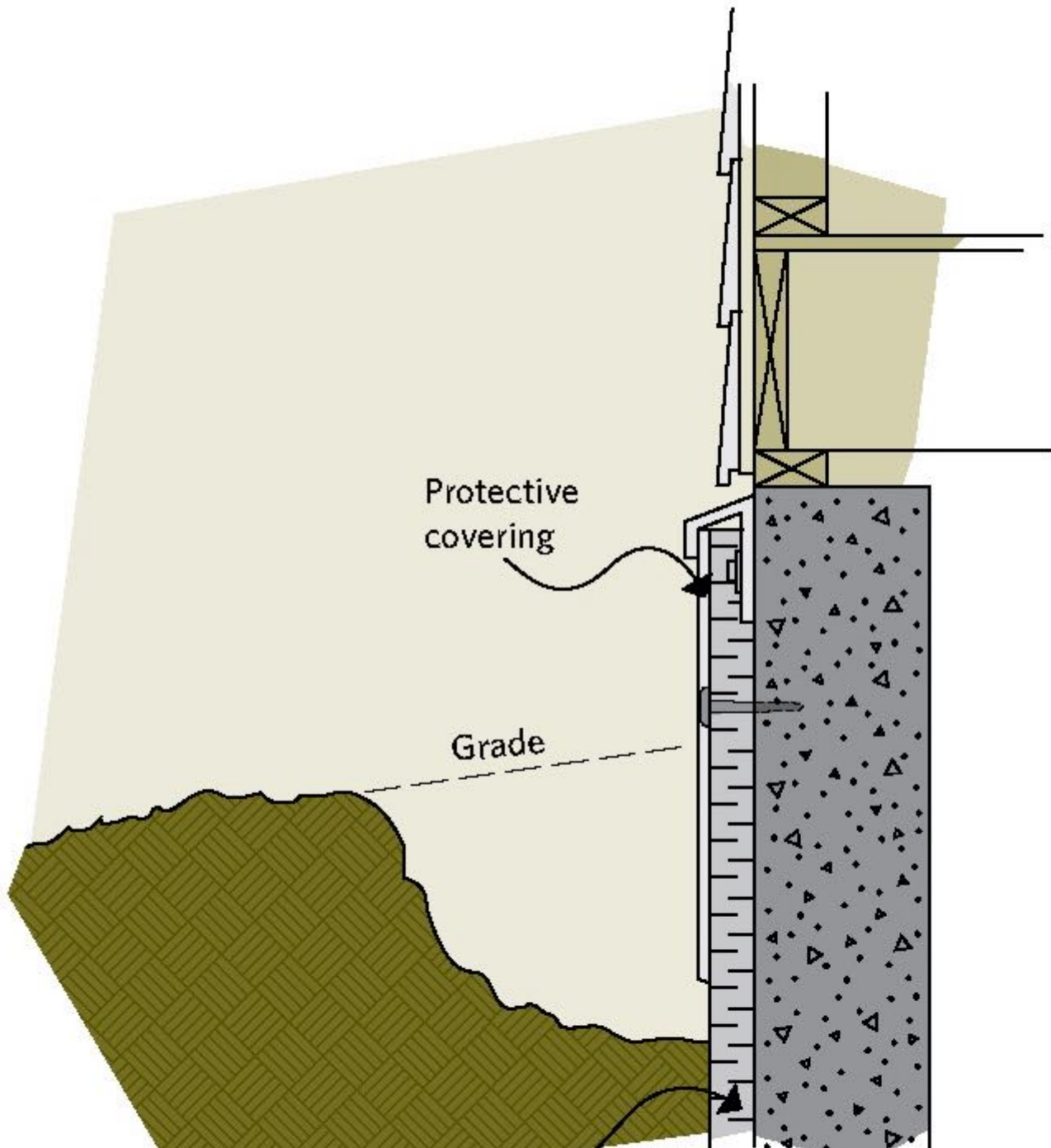
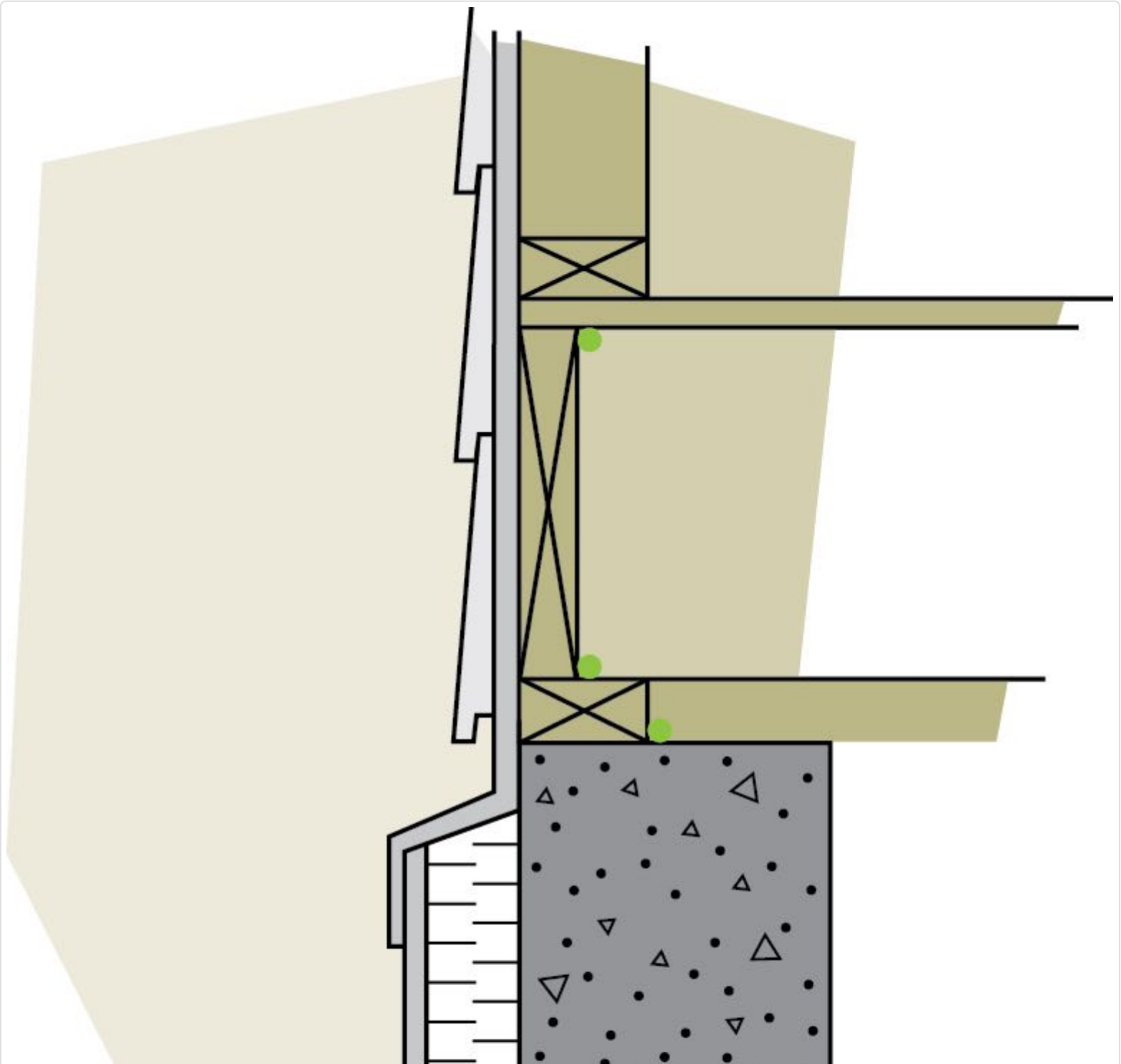



Figure 6-9 Exterior protection should extend below grade

[Larger image](#)



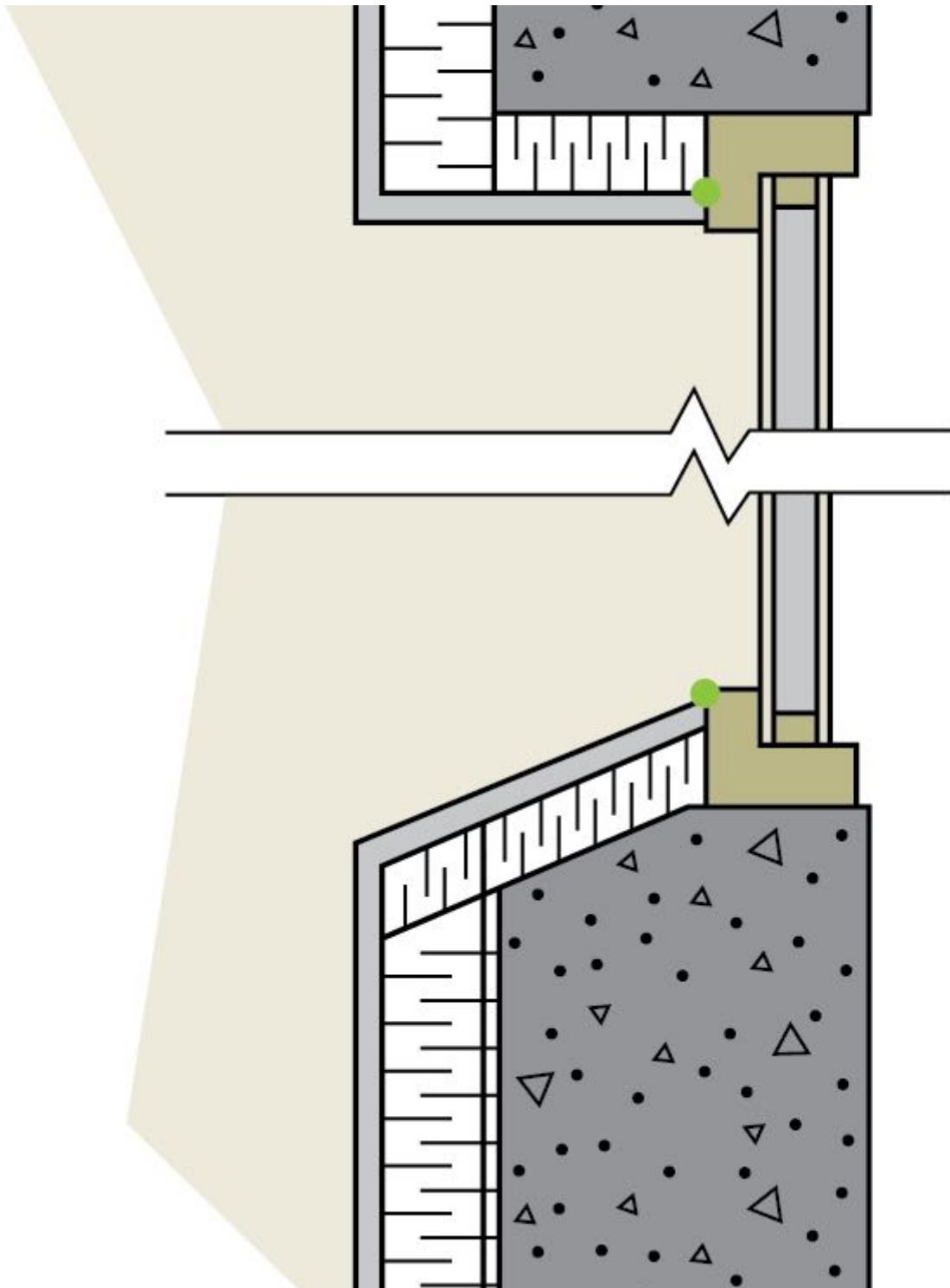



Figure 6-10 The sill should slope away from the window

Larger image

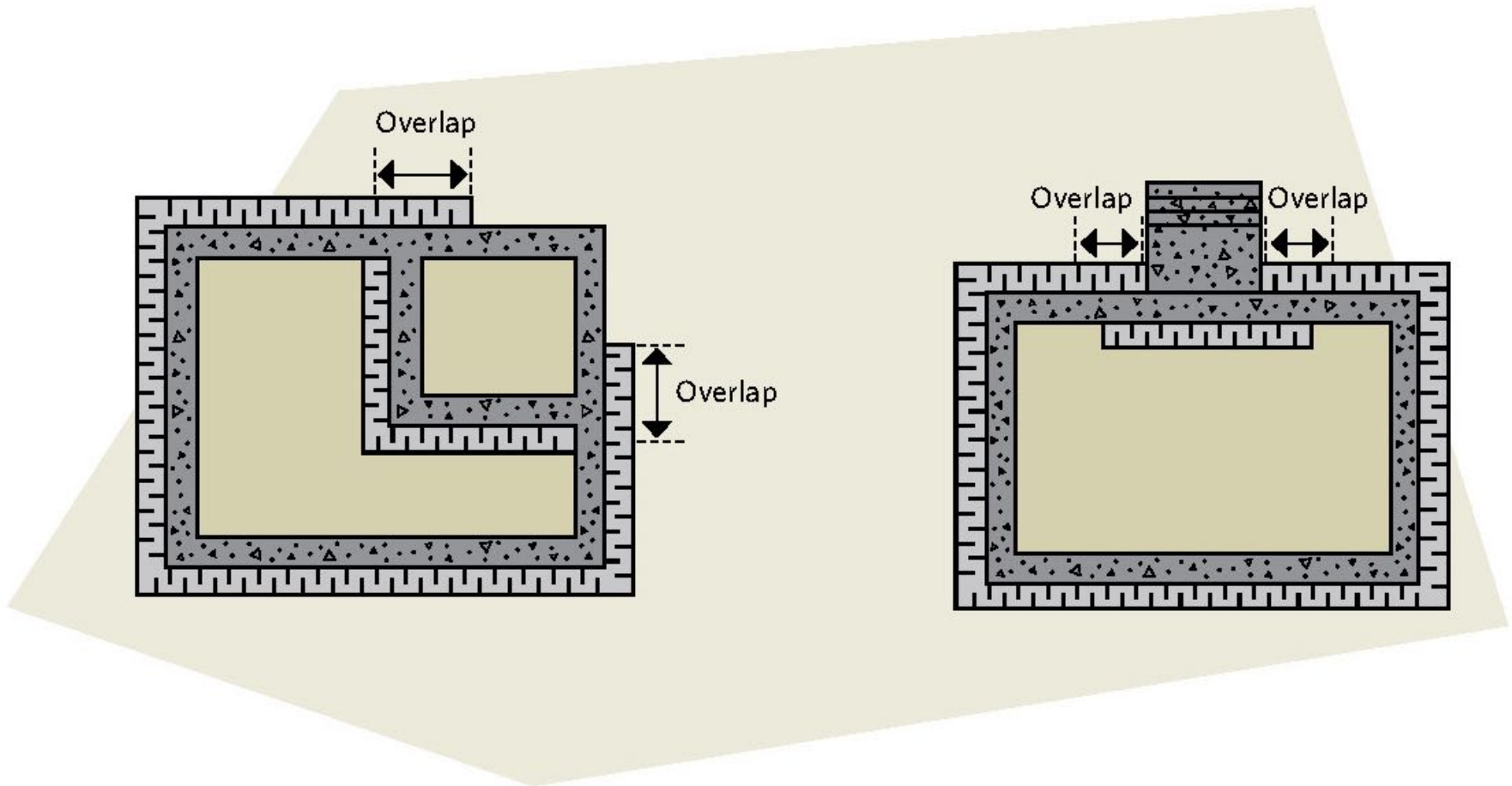

Figure 6-11 Overlapping foundation insulation at places where insulation cannot be put on the exterior

Larger image

Rigid plastic board insulation generally has a higher RSI value per millimetre than batt insulation and requires less basement space and a thinner supporting framework. (See Section 3.1, Insulation, for more information.)

⚠ SAFETY WARNING:

When working inside basements, refer to Section 1.4, Health and safety considerations, and follow those guidelines. In addition, because powder-activated concrete fastening tools are often used in basement renovations, carefully follow usage directions.

6.2.1 How to insulate inside the basement using only rigid board insulation

This method works best if the basement wall is even and vertical (i.e. poured concrete or concrete block) as the board material is fairly rigid. Secure rigid and moisture impermeable insulation panels to the concrete using mechanically attached fastening strips and then protect the assembly by attaching 12.7 mm (½in.) gypsum drywall to the fastening strips (see Figure 6-12 for details). Electrical outlets and switches will typically be surface-run.

Preparation

After checking the wall and making any necessary repairs, air seal all leakage paths such as at the sill and around penetrations. This important step provides the primary air barrier system.

As the insulation board is acting as a moisture barrier, use medium- to high-density foam board with good moisture resistance properties such as extruded polystyrene and Type IV expanded polystyrene. Foil-faced insulation board may deteriorate in contact with cement and mortar, so check with the manufacturer before using.

Installation

The insulation can be sealed to the foundation by applying foam-compatible adhesive around the perimeter of the foam board before fastening it to the wall. If any mould were to develop behind the insulation, it would be contained. Air sealing the foam board to the wall creates an air and moisture barrier somewhat equivalent to spray foam.

As mechanical fasteners are essential to secure the gypsum board to the wall, use wooden fastening strips on top of the insulation. Alternatively, insulation can be held in place with special wood or metal fastening strips that fit within grooves or notches factory-cut in the insulation panels. In either case, screw or nail the drywall to the strip that has been secured to the concrete with corrosion-resistant concrete fasteners.

Install a minimum of RSI 2.1 (R-12) unless local building codes require more. Consider installing insulation in overlapping layers to minimize heat loss through any fastening strips. Fit the insulation snugly to eliminate air circulation at the edges and use foam caulking and technical tape to seal all joints and intersections.

Finishing

Insulate and seal the joist area (unless the joists are embedded in concrete). See joist header space later in the part. Protect the entire wall with 12.7 mm (1/2-in.) gypsum board or equivalent fire protection. This includes the joist space if a new ceiling is not installed.

6.2.2 How to frame and insulate inside the basement

There are three common methods for insulating the interior of a basement incorporating a frame wall. Each method should be assessed on basic principles of practicality: the ability to do the work yourself, the cost of materials and labour if contracted out, and the expected outcome (e.g. will it be a finished basement or just storage space?).

The three current approaches are

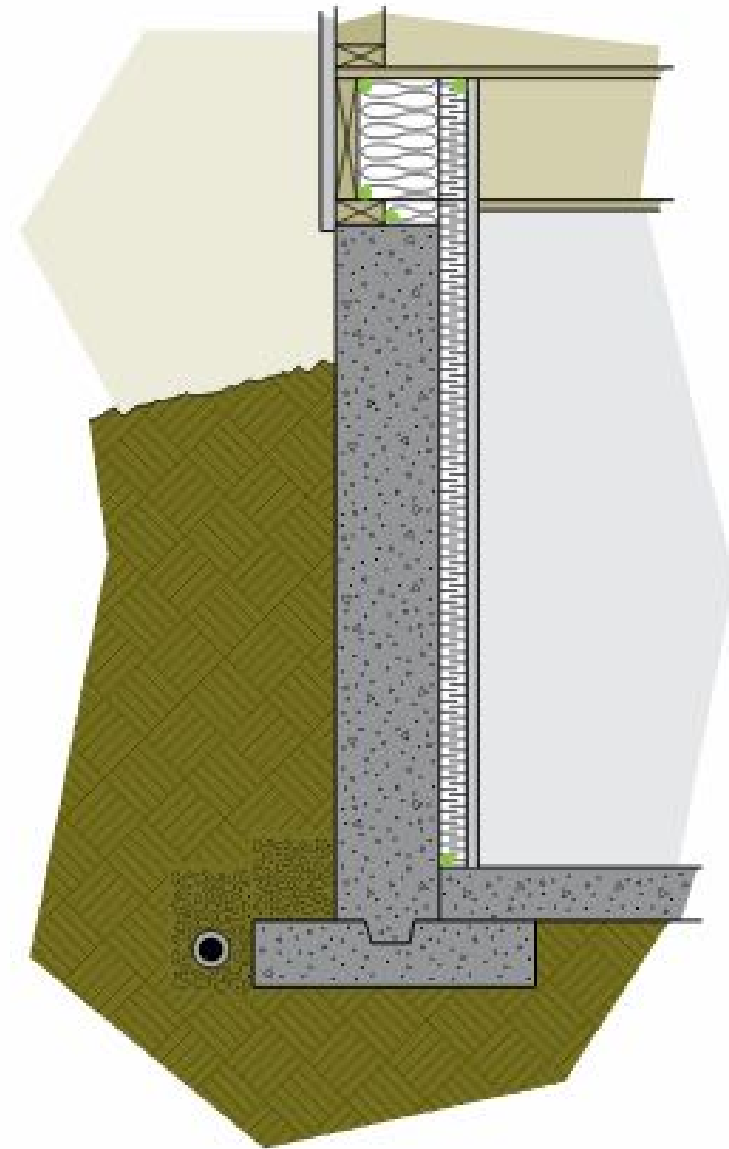

Rigid board insulation involves

1. air sealing the old walls
2. installing the insulation
3. finishing

- frame wall with single or double layer of batt insulation
- frame wall filled with batt insulation and rigid board insulation backing
- frame wall filled with batt insulation and spray foam backing

Figure 6-12 Insulating with rigid insulation from the interior

[Larger image](#)

Preparation

After checking the wall and making any necessary repairs, air seal all leakage paths such as at the sill and around penetrations. This important step provides the primary air barrier system.

For information about materials and techniques, see Chapter 3, “Materials,” and Chapter 4, “Comprehensive air leakage control.”

i TECHNICAL NOTE:

Use dry lumber for the framing. If the lumber is not dry, allow the framing to dry for at least two weeks before adding insulation and covering the wall with the air and vapour barrier. Temporary bracing may be tacked on to the framing to keep the wet studs from twisting as they dry.

6.2.3 Frame wall with single or double layer of batt insulation

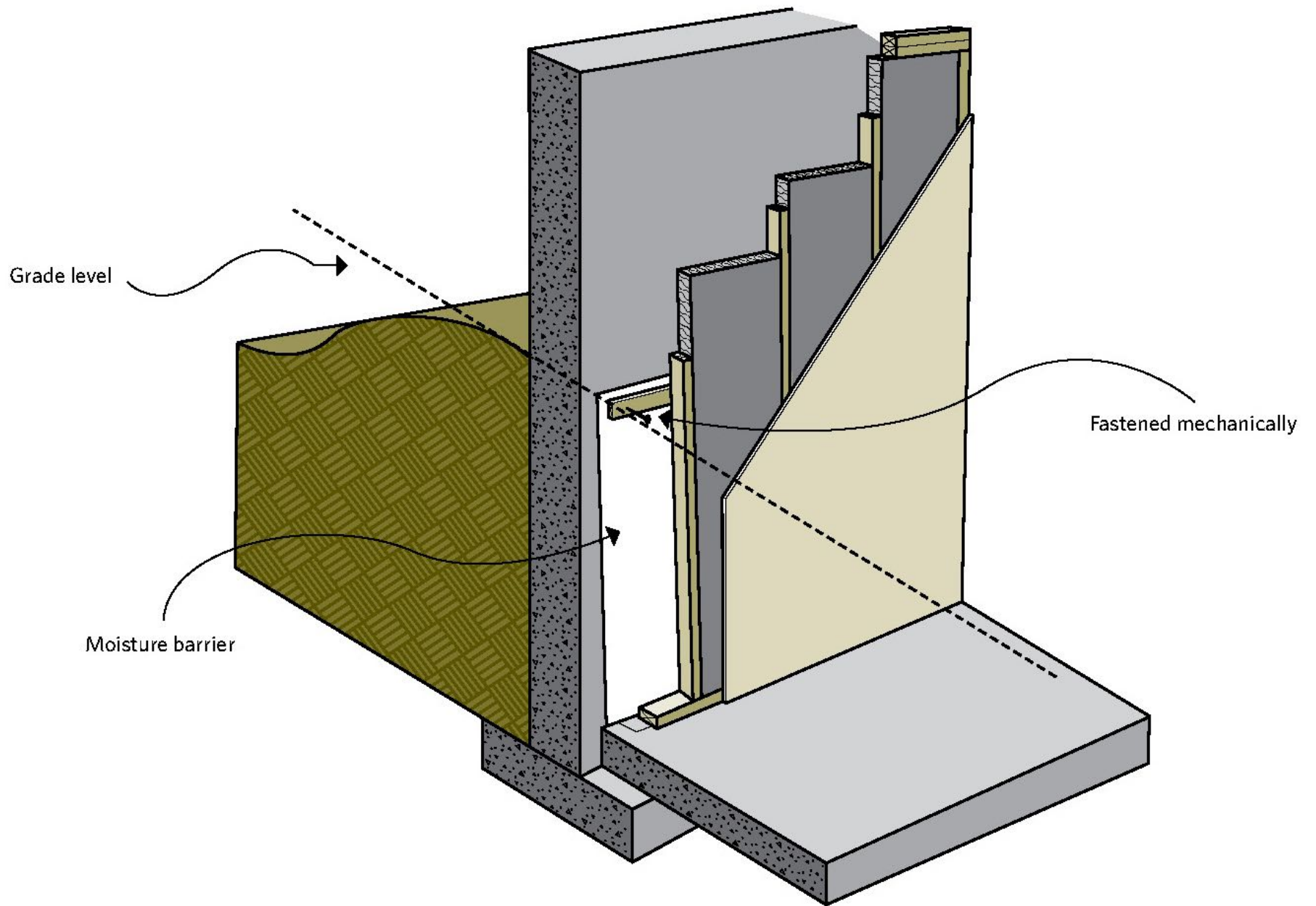

Figure 6-13 Framed wall with batt insulation

[Larger image](#)

To protect the insulation, framing and wall finish from possible water damage, cover the basement walls with house wrap. Plastic was once the material of choice, but in some cases where air and moisture entered the insulated wall, condensation formed on the plastic and caused wetting and mould issues within the wall.

By using house wrap, moisture (not excessive and not leakage) that penetrates the new wall will dry out either into the interior of the house or to the top of the foundations that are above grade. The building paper should start at or just above the grade line and extend down to the basement floor and under the bottom plate of the frame wall. Mechanically support it with strapping such as 1 x 3 lumber.

SAFETY WARNING:

Do not use asphalt building paper (tar paper) inside of the house because it can release toxic vapours.

Framing

The next step is to install a frame wall. You can use one of two approaches:

- Install the wall close to but not touching the house wrap (12-mm [$\frac{1}{2}$ -in.] spacing) using 2 x 4 or 2 x 6 lumber.
- Position the framing further away from the foundation wall to allow for a layer of batt insulation between the framing and the wall.

Allow enough room for a firm fit without compressing the insulation.

The second approach takes up more interior room but provides more insulation, less thermal bridging through the studs and better moisture protection. The bottom plate should sit on top of the extension of the house wrap and on a continuous impermeable membrane such as a sill gasket (see Figure 6-14).

Next, fasten the top plate to the bottom of the joists. Where the wall runs parallel to the joists you will have to build in a nailing support for the top plate (the approach you use will depend upon your particular house). Now is the time to square up the walls.

If your home is in an area of expansive clay soils, you may have to include a 25 mm (1 in.) gap between the top plate and the bottom of the floor joists to allow for vertical movement of the basement slab/floor. Talk with your local building authorities about how to best handle this situation.

Next, install the studs 610 mm (24 in.) on centre (i.e. measured from the centre of one stud to the centre of the next). Confirm that this spacing will offer structural support for your finishing needs. Make sure that the studs are perfectly vertical and accurately spaced so that the insulation will fit snugly and the finish can be installed without problems. Measure each stud separately. Extra framing is needed around doors in the foundation, but window openings only need a single stud, as the wall is non-load bearing.

If all alignments are perfectly level and square and there are no obstructions, you may be able to build the wall on the floor, tilt it into place, shim the bottom plate and secure the wall frame in place. Then install any required wiring and plumbing rough-ins.

Insulating

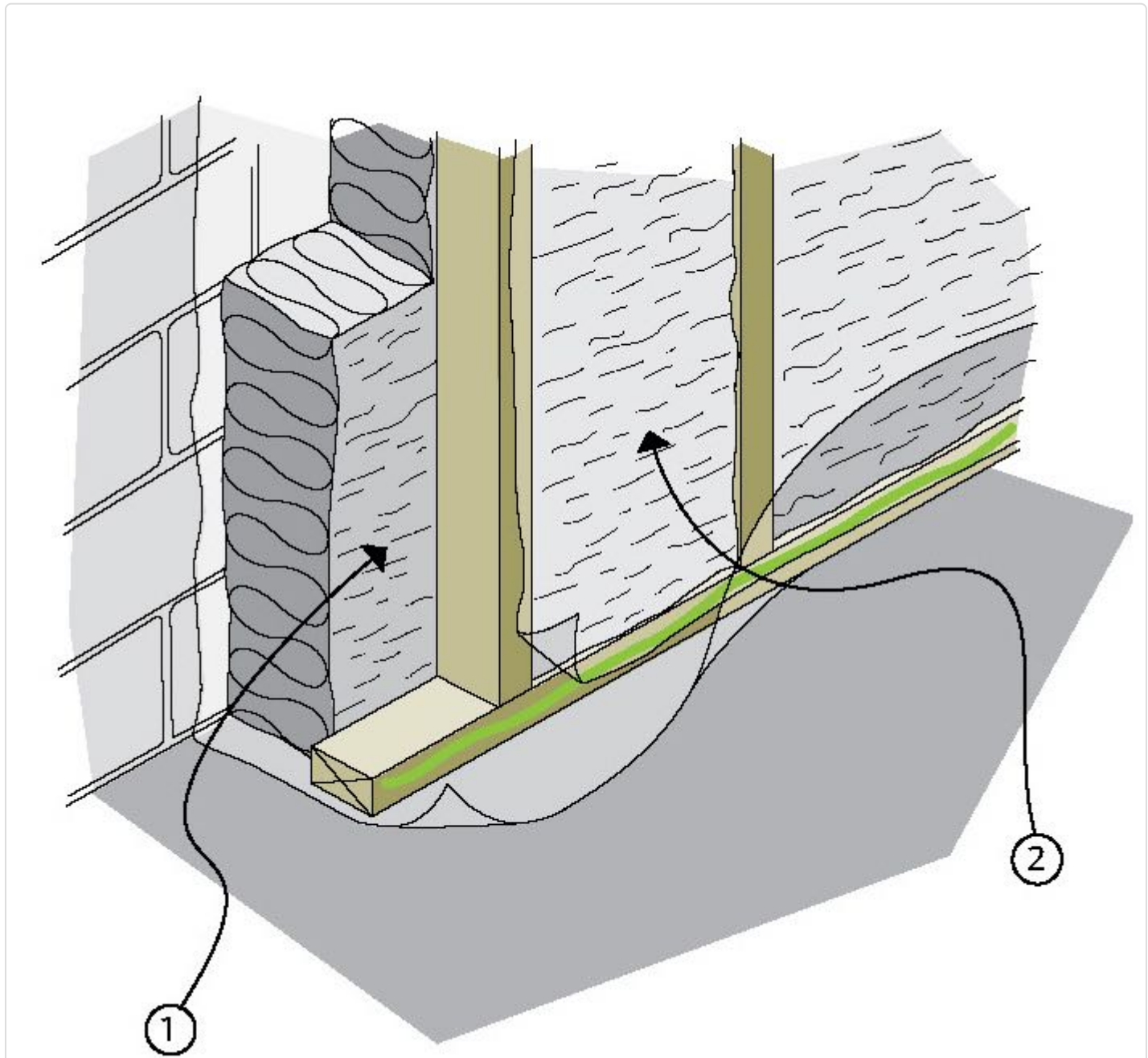

Two layers of insulation can be used:

If you left a space behind the frame for batt insulation, you can now add the insulation between the studs and the wall in a horizontal layer. The insulation must be tight against the foundation wall.

1. horizontally between the foundation wall and the studs
2. vertically between the studs

Figure 6-14 Double layer batt insulation in a framed wall

[Larger image](#)

Next, fill the frame wall with a

vertical layer of batt insulation fitting it snugly between the studs, allowing no gaps, air spaces or over-compression. Alternatively, if using fibreglass blown-in insulation, fill all cavities to the manufacturer's recommended density and RSI level.

Finishing

Install a vapour barrier over the studs and insulation. In basements that have proven to be dry, a polyethylene vapour barrier is suitable. However, if you have any doubts or there is a risk of dampness in the basement, there are two alternate methods that may be better suited.

The first alternate method is to use polyamide sheeting, a breathable membrane also known as Nylon-6 vapour retarder film or smart barrier. When installed on the warm side of an exterior wall, smart barrier has a water vapour permeance that changes with the conditions within the wall. If the relative humidity in the wall cavity increases, the smart barrier will allow the wall to dry out toward the interior unlike other sheet-type vapour barriers. If you are using smart barrier, carefully follow manufacturer's directions and installation requirements, though its application is similar to polyethylene sheet with a few important exceptions.

Leave enough of either the polyethylene or smart barrier at the top to connect to the air barrier in the joist header space. Seal all edges, seams and penetrations with acoustical sealant or other approved materials. All joints should overlap over a stud and be sealed with a continuous bead of sealant that is run between the layers of material at the lapped joints. Staple the barrier to the stud through the bead of sealant (see detail in Figure 4-3).

The second alternate method is to use an air and vapour barrier system known as the airtight drywall approach (ADA). The ADA method uses rigid materials, typically drywall, very carefully and thoroughly sealed to the framing and all other component connections by using adhesive-backed foam tape and flexible caulking.

Attention to detail is critical. The ADA method works only if it is completely sealed and tied into the air and vapour barrier system in the rest of the house. The following is a non-inclusive list of ADA sealing considerations:

- Frame airtight boxes for plumbing, water and drain line penetrations with gasket on the face of the box and caulk the pipe penetrations (see Figure 3-6 and Figure 6-16).
- Use special airtight electrical switch and plug boxes that include a gasket on the face of the box and caulk all wire penetrations.
- Do not run wiring or plumbing from exterior walls into interior walls unless all holes are caulked (see Figure 6-16).

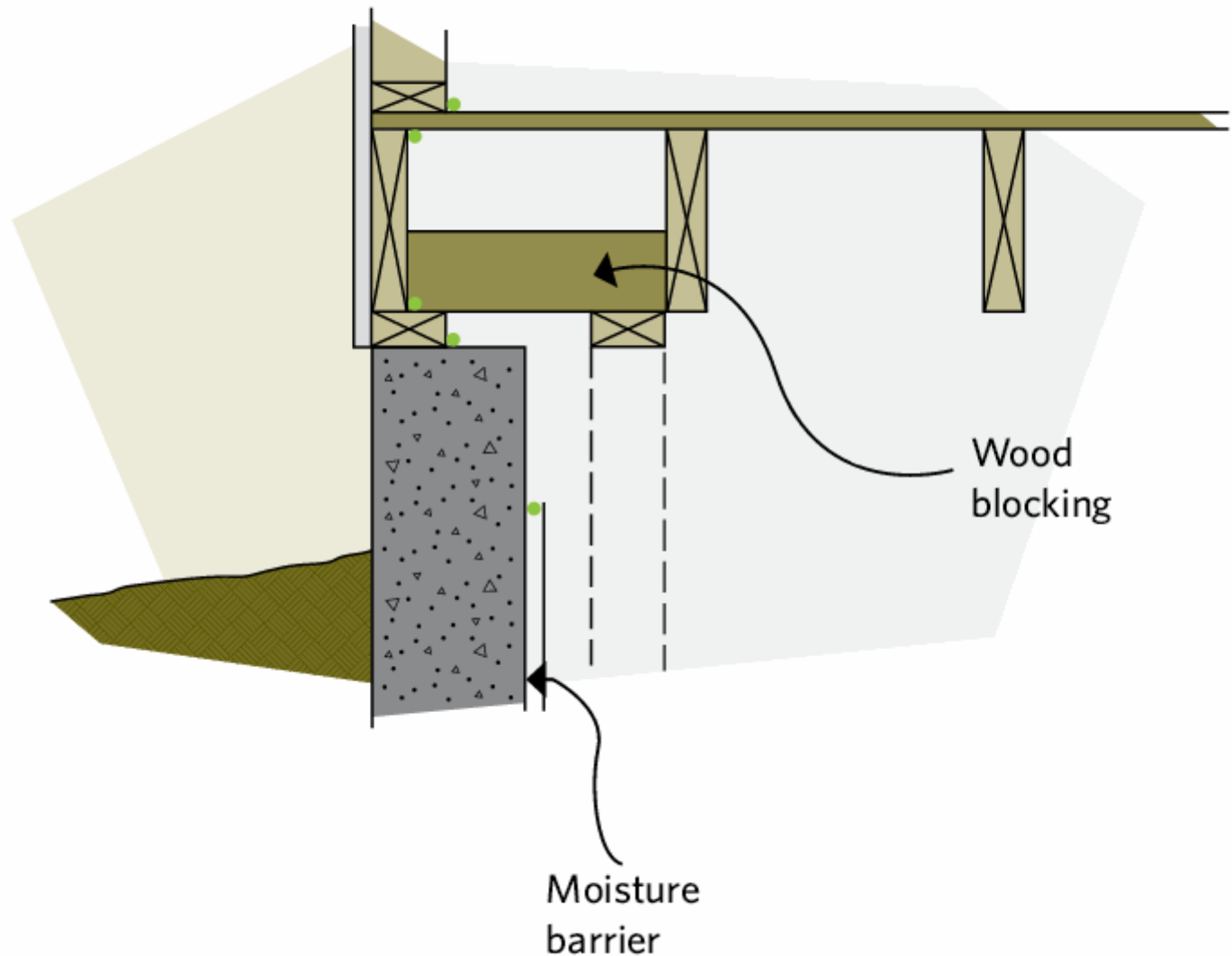

Figure 6-15 Top plate detail where the joists run parallel to the wall

[Larger image](#)

- Air seal all window and door frames using expanding foam and appropriate caulking (see Figure 7-7).
- Install foam gaskets and caulk the upper edge of the top plate and all other framing members that are in direct contact with floors, slab, interior walls and ceiling.
- Air seal all edges and perforations of obstructions such as stairs that are against the exterior wall.
- Frame in and air seal separately any electrical panels that are not surface mounted on the finish and then air seal all penetrations.
- Remember to insulate and seal the joist header space (explained later in Section 6.2.6, Joist header space) before attaching the finishing surface. This area is particularly prone to air leakage and must be properly sealed and insulated as part of any basement retrofit.
- Finishing must include a vapour barrier primer or paint.

6.2.4 Frame wall with batt insulation and rigid board insulation

This method involves gluing rigid board insulation to the foundation wall and then covering it with a frame wall incorporating batt insulation. The result is higher insulation values with less loss of interior space, a very good reduction of thermal bridging and no need for an additional moisture barrier. It works best if the basement wall is even and vertical (i.e. poured concrete or concrete block) as the board is fairly rigid. Use only moisture-resistant board insulation such as extruded polystyrene or Type IV expanded polystyrene.

Preparation

Follow the preparations required in Section 6.2.1, How to insulate inside the basement using only rigid board insulation.

Installation

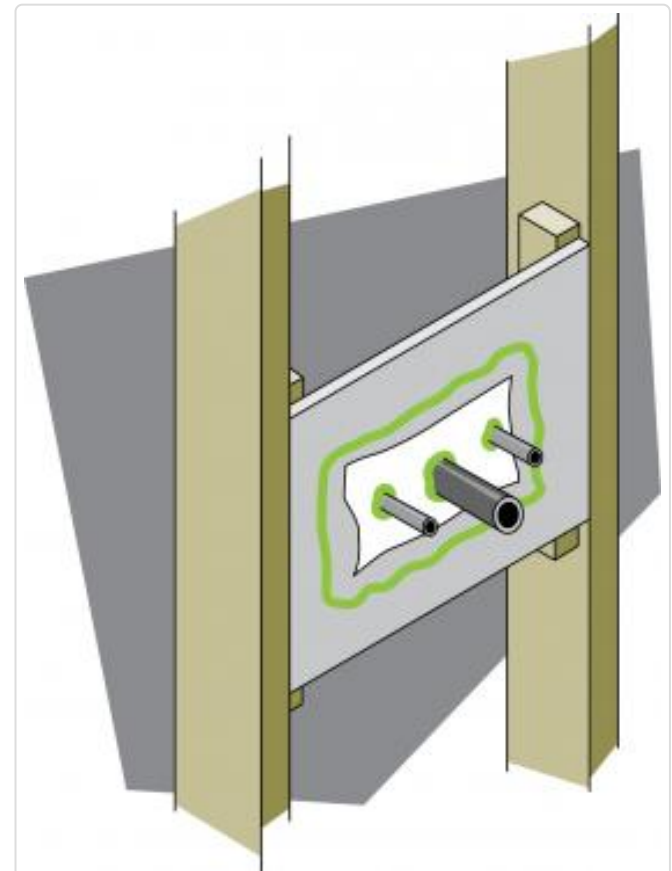

Figure 6-16 Sealed plumbing penetrations

[Larger image](#)

Using rigid board insulation with at least RSI 1.76 (R-10), secure and seal it to the foundation by applying foam-compatible adhesive around the perimeter of the foam board before fastening it to the wall. If any mould were to develop behind the insulation it would be contained. Air sealing the foam board to the wall creates an air and moisture barrier somewhat equivalent to spray foam. Special mechanical fasteners can be used if you have any sensitivity to the glue. Install the insulation snugly to eliminate air circulation at the edges. Use urethane foam sealant and technical tape to seal all joints and intersections of the foam board.

Next, install the wood-frame wall directly in contact with the rigid board insulation. Follow the techniques detailed in Section 6.2.3, Frame wall with single or double layer of batt insulation.

Adding additional insulation

The frame wall can now be roughed in for any wiring and plumbing and insulated as noted previously in Section 6.2.3, Frame wall with single or double layer of batt insulation. For details on treating the joist area, see Section 6.2.6, Joist header space.

Finishing

Do not use a polyethylene air and vapour barrier with this approach, as there is a risk of creating a double vapour barrier with the foam board. Instead, use either the smart barrier or the ADA method.

If you are using smart barrier, leave enough of the film at the top to connect to the air barrier in the joist space.

If you are using the ADA method, pay strict attention to proper air and vapour sealing, including a layer of vapour barrier paint. Any exposed foam insulation may require fire protection as per code requirements.

6.2.5 Frame wall with batt insulation and spray foam backing

This is becoming a popular hybrid method of insulating. It involves building a frame wall 25 to 50 mm (1 to 2 in.) away from the foundation and then having a professional spray-foam contractor install about 50 mm (2 in.) of medium or high density polyurethane foam against the wall. The spray foam fills and bonds directly to the framing members and the wall, offering high insulation value (about RSI 0.98 [R-5.6/in.]) while reducing thermal bridging and providing a moisture barrier. The frame wall is then filled with insulation.

The primary limitation of this approach is higher cost, although its use reduces the need for additional materials and labour (see Figure 6-17).

Preparation

Discuss with the spray foam contractor on site what should be done before starting the spraying. Major issues such as active structural cracks and frequent and major water leaks must be addressed first.

Install the wood frame wall at a distance from the foundation as directed by the contractor, including both sides of the corner studs. Follow the framing techniques discussed in Section 6.2.3, Frame wall with single or double layer of batt insulation.

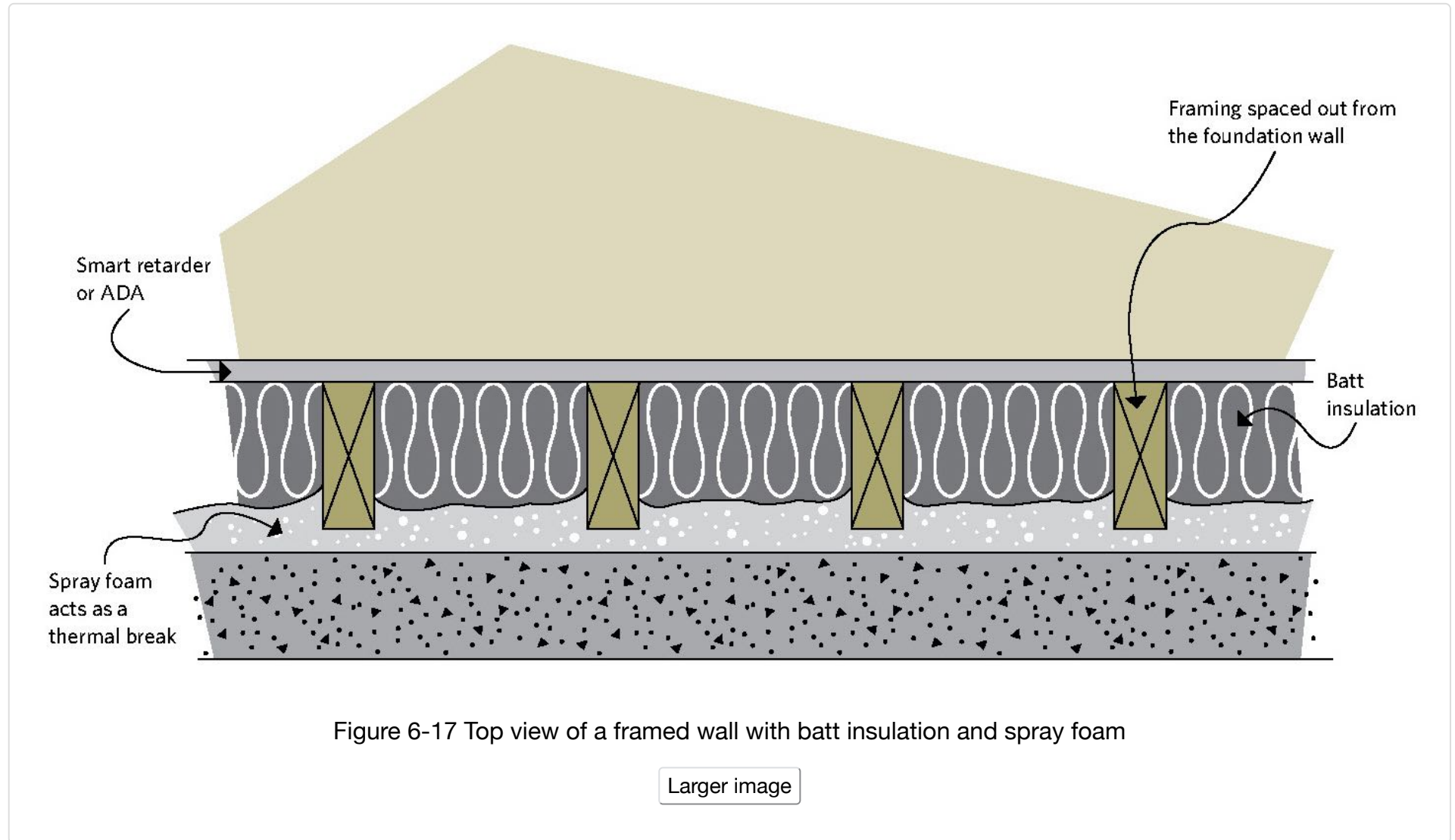

Adding additional insulation

Once the contractor has installed the foam, the frame wall can be roughed in for wiring and plumbing and insulated. Again, a polyethylene vapour barrier is not recommended.

For details on treating the joist area, see Section 6.2.6, Joist header space. For finishing, see the previous frame wall method in Section 6.2.3, Frame wall with single or double layer of batt insulation.

6.2.6 Joist header space

The joist header space is also called the rim joist space, foundation header space or simply the joist space. This is the area where the floor joists intersect and are supported by the foundation walls in both basements and crawl spaces. Put simply, it is the area where the house structure rests on the foundation. This area is prone to air leakage and is seldom properly insulated, resulting in unwanted drafts, dust and pollen entry and vermin access.

There are three major joint configurations, each with implications on how best to air seal and insulate:

- floor joists on a sill plate (Figure 6-18, Part A and Figure 6-19, Part A)
- floor joists partially embedded in the foundation (Figure 6-18, Part B and Figure 6-19, Part B)
- floor joists fully embedded in the foundation (Figure 6-18, Part C and Figure 6-19, Part C)

If it is not possible to extend the exterior foundation insulation to cover the full header joist area, the space will have to be insulated and sealed from the inside.

If the foundation walls are insulated from the interior, the air and vapour barrier must be continuous for the wall and header space.

Figure 6-19 shows how to air seal and insulate three common types of joist header spaces.

For fully-embedded joists, do not exceed a maximum of 25 mm (1 in.) of foam board insulation as the concrete below the floor may make the floor above uncomfortably cold and prone to damage.

For all the approaches illustrated in Figure 6-18 and Figure 6-19, building codes may mandate levels of insulation, so check with your local authorities as to the recommended levels and practices.

Polyurethane spray foam installed by a certified contractor offers excellent air sealing and insulation of this space. However, the foam must be covered with fire-resistant material if it is not covered by the basement ceiling.

A) Floor joists on a sill plate

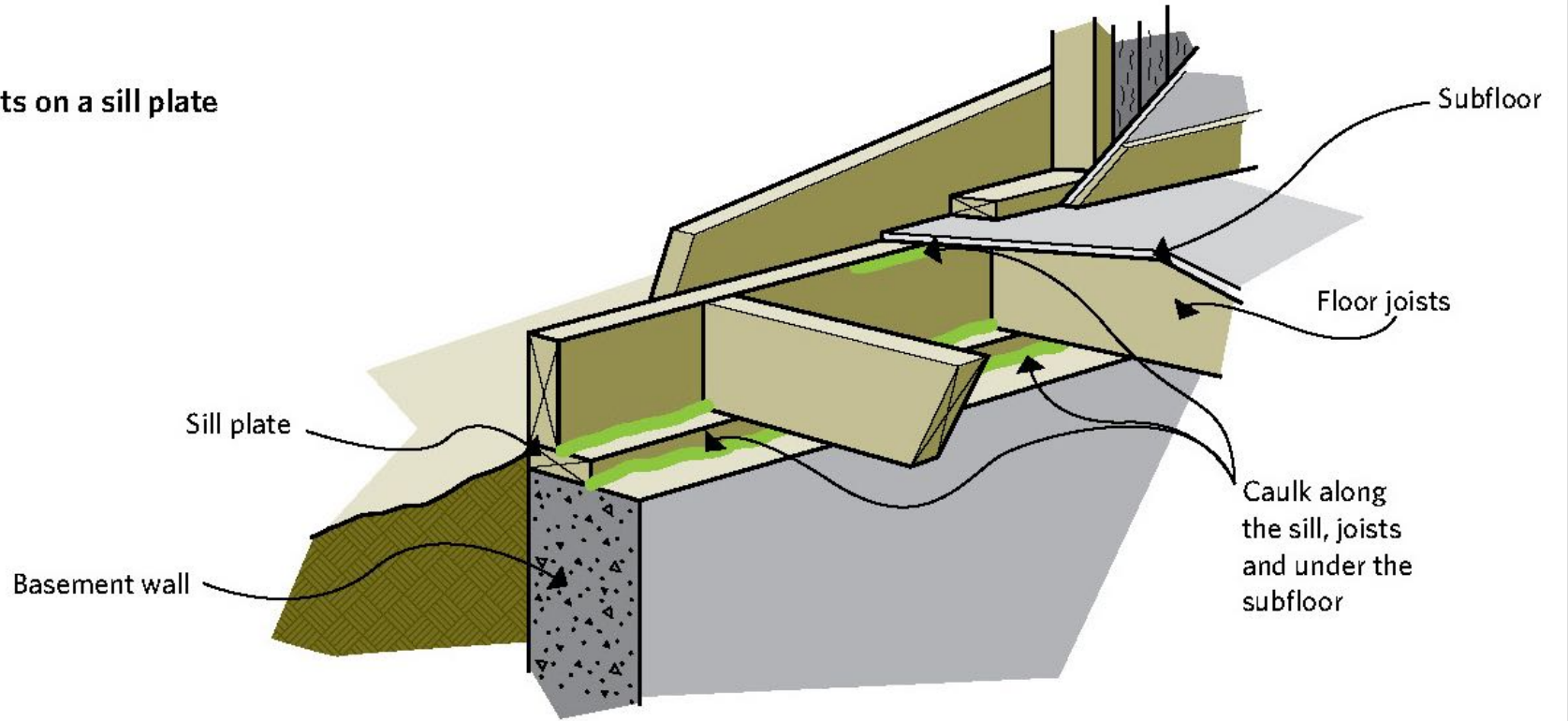

B) Floor joists partially cast-in

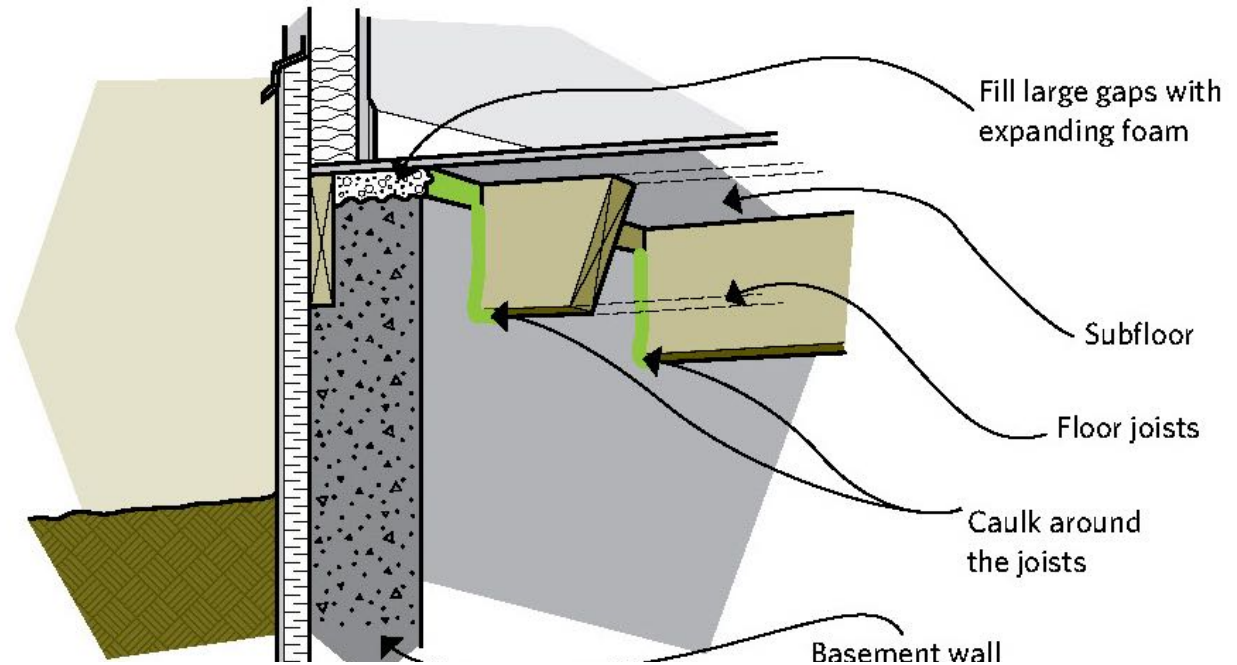

C) Floor joists fully cast-in

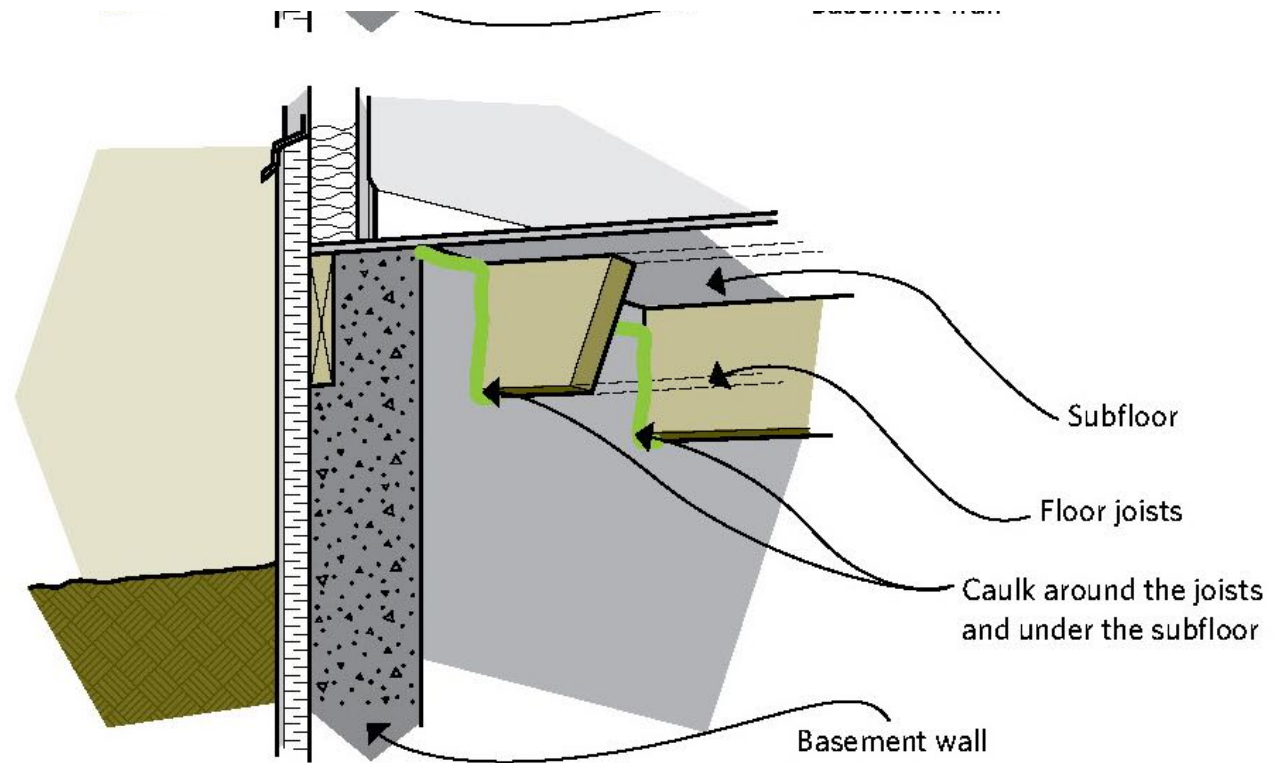
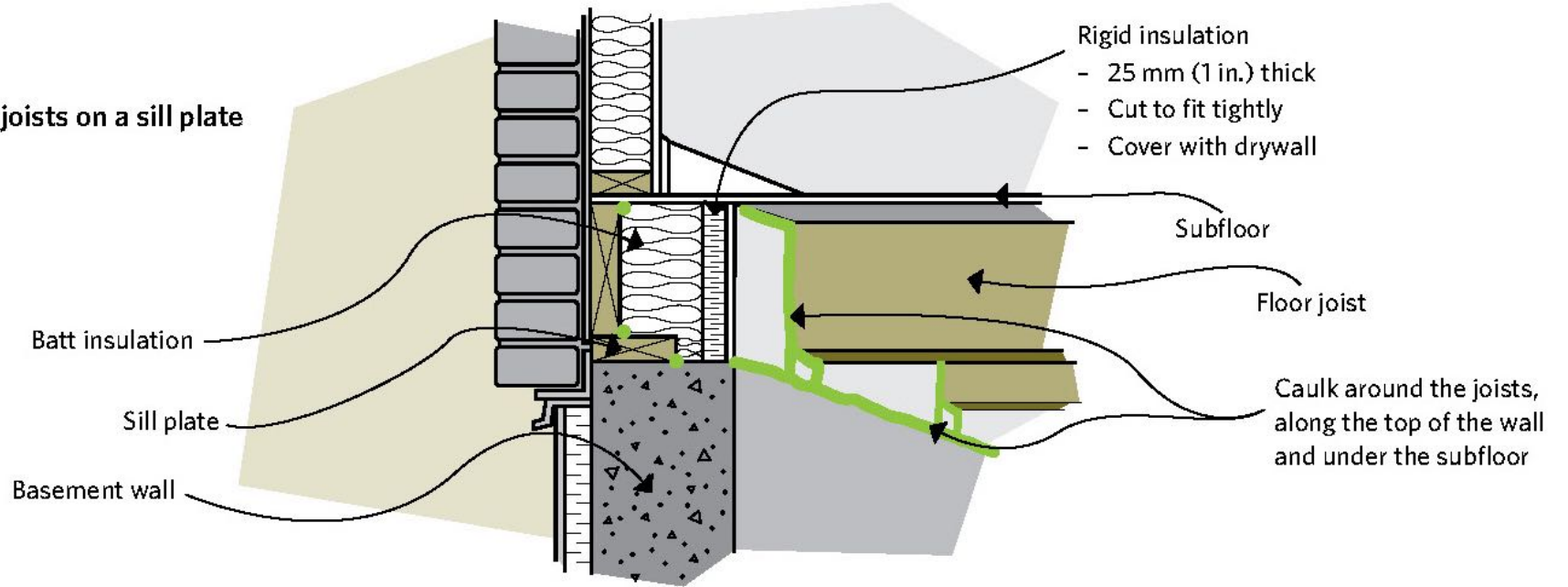

Figure 6-18 Reducing air leakage in the joist header area

[Larger image](#)

► [Text Version](#)

A) Floor joists on a sill plate



B) Floor joists partially cast-in

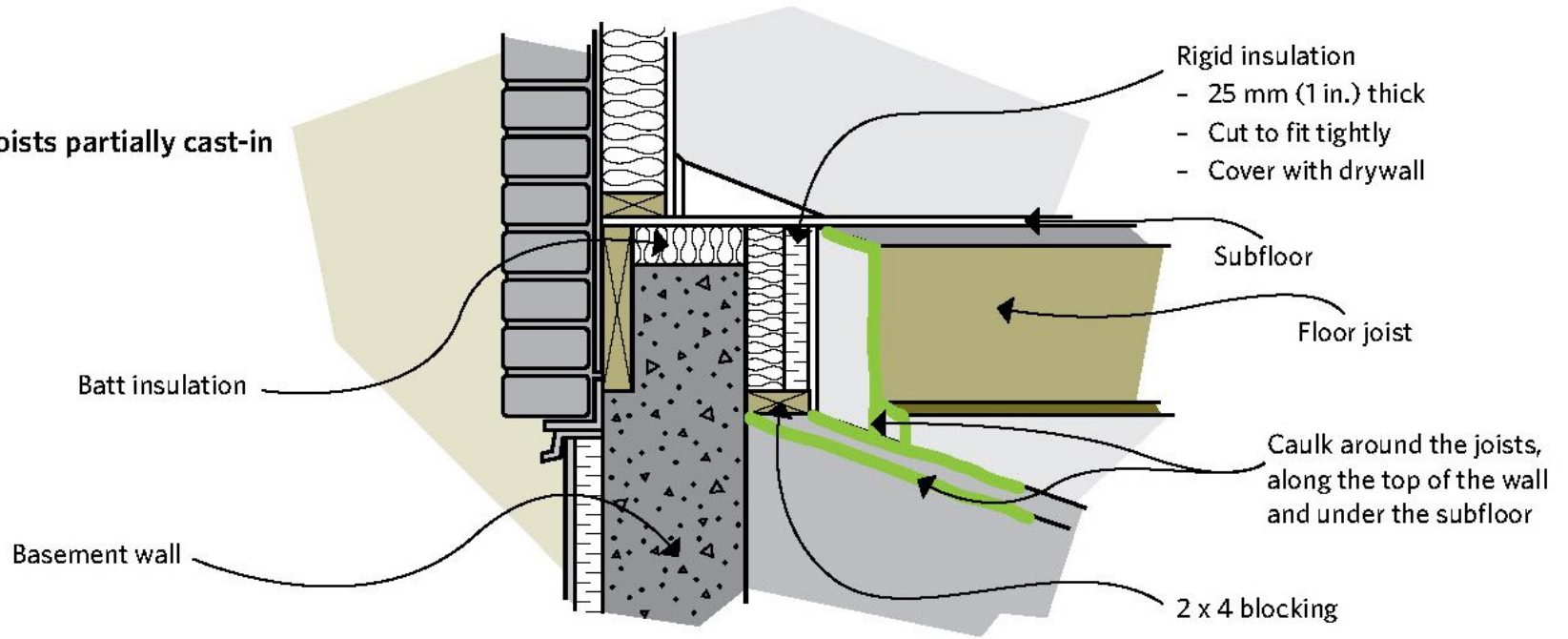

C) Floor joists fully cast-in

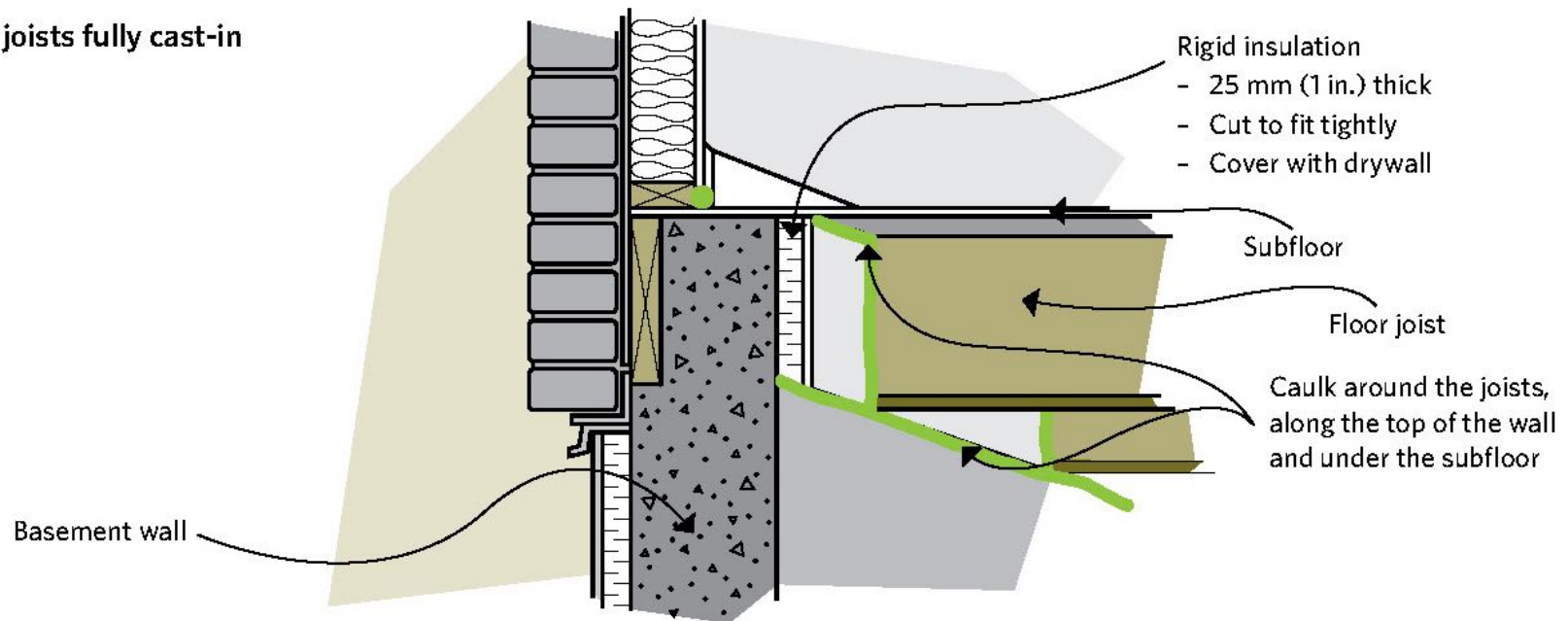

Figure 6-19 Insulating the joist header area

[Larger image](#)

[▶ Text Version](#)

6.2.7 Complications

The following issues can complicate the process of installing insulation:

Wall space interrupted by pipes, ducts or an electrical panel

- Move water lines away from the wall or install the insulation and vapour barrier behind the pipes so that they are on the warm side. Never place insulation in front of pipes. Any pipes that pass through the air and vapour barrier should pass through a

plywood box sealed to the main air and vapour barrier and the gaps around the pipes caulked.

- Do not insulate around flue pipes. Different clearances are needed depending on the type of flue. Check with the manufacturers or a heating system specialist. Similarly, do not insulate if you cannot maintain the proper clearances between furnaces, wood stoves and the wall.
- Be careful working around electrical panels. Even when the power to the rest of the house is off, the panel will still be live. Have an electrician help seal or move the panel to accommodate the new wall.

Basement wall interrupted by a window

- Using low-expansion spray foam caulk, seal the point where the window frame adjoins the wall. Then seal frames to the vapour barrier system.

6.2.8 Rubble and irregular basement and crawl space walls

An irregular basement is usually made of stone or rubble and is rarely waterproofed on the outside (see Figure 6-2). While an exterior retrofit is always recommended, it may be possible to insulate on the inside if there are no water or moisture problems.

First, cover the interior wall with cement-based parging to smooth the surface and to protect the existing mortar. Then build a frame wall, add a maximum of RSI 2.1 (R-12) batt insulation and finish as previously described in Section 6.2.3, Frame wall with single or double layer of batt insulation.

In general, do not go with higher insulation values as there is a risk that the wall may be subjected to damaging freeze-thaw cycles. Check with your local building authorities for more information on how to deal with this potential problem.

Closed-cell spray polyurethane foam has been used successfully to reduce dampness problems for rubble walls while offering some thermal protection value. Do not exceed RSI 2.1 (R-12). This product must be installed by a certified installer and be covered by an appropriate fire-resistant material.

For very wet basements prone to flooding and high moisture problems, it may be best not to insulate the basement walls. Instead, consult your building authorities and an experienced general contractor about the potential to treat the floor joist space as an exposed and insulated floor.

Additional modifications will be needed to take care of the plumbing and heating system.

6.2.9 Part of the basement is a cold cellar or an unheated garage

Apply the insulation to the cold cellar or garage wall separating the heated basement from the unheated space, as if it were an external wall. Weatherstrip and insulate the doorway from the basement. Insulate the ceiling as described in Section 6.4, Open foundations, as well as Figure 6-11.

If you insulate your cold cellar, check on the winter temperature so you can make adjustments to prevent freezing. If the room is still too warm or the floor above is cold, you may want to insulate the ceiling of the cold room (see Section 6.4, Open foundations).

6.2.10 Basement pony walls

A pony wall consists of a short wood frame wall sitting on top of a conventional concrete foundation. In this case, the wood frame section is insulated between the studs, and the concrete section is insulated on the interior (assuming there are no moisture problems). The insulation on the concrete is extended up about 200 mm (8 in.) to overlap with the frame section. A ledge is created at this point (see Figure 6-20). To avoid a ledge, install a frame wall from floor to ceiling and fill the cavity with insulation.

This method will offer higher thermal performance but creates a deep window frame.

6.2.11 Overhangs

Seal and insulate floors that overhang the foundation. It is usually possible to remove the finish underneath the overhang and air seal the space between the joists above the foundation with polyurethane foam or with caulked, low-permeability rigid insulation. Insulate the joist space with batt or blanket insulation and add an air barrier before re-installing the finish.

In some cases, a layer of rigid board insulation with protective outer finish can be applied to the underside of the overhang, but the space should still be air sealed and insulated. Alternatively, a contractor can spray foam into the cavities or blow in dense-pack fibre insulation through holes drilled to the underside.

6.2.12 Basement floors

As most heat is lost through the upper part of the foundation walls, basement floor slabs are seldom insulated. For improved comfort, moisture control and radon reduction, apply a moisture barrier to the floor or seal the floor to prevent moisture accumulation between the insulation and the slab. Alternatively, you may install a floor drainage system under the new floor.

If you are installing or replacing a concrete slab floor, this offers an excellent opportunity to have in-floor heating installed or to have it made *radiant-ready*. Radiant-ready is where insulation and heating lines are installed before pouring the new slab, allowing for future

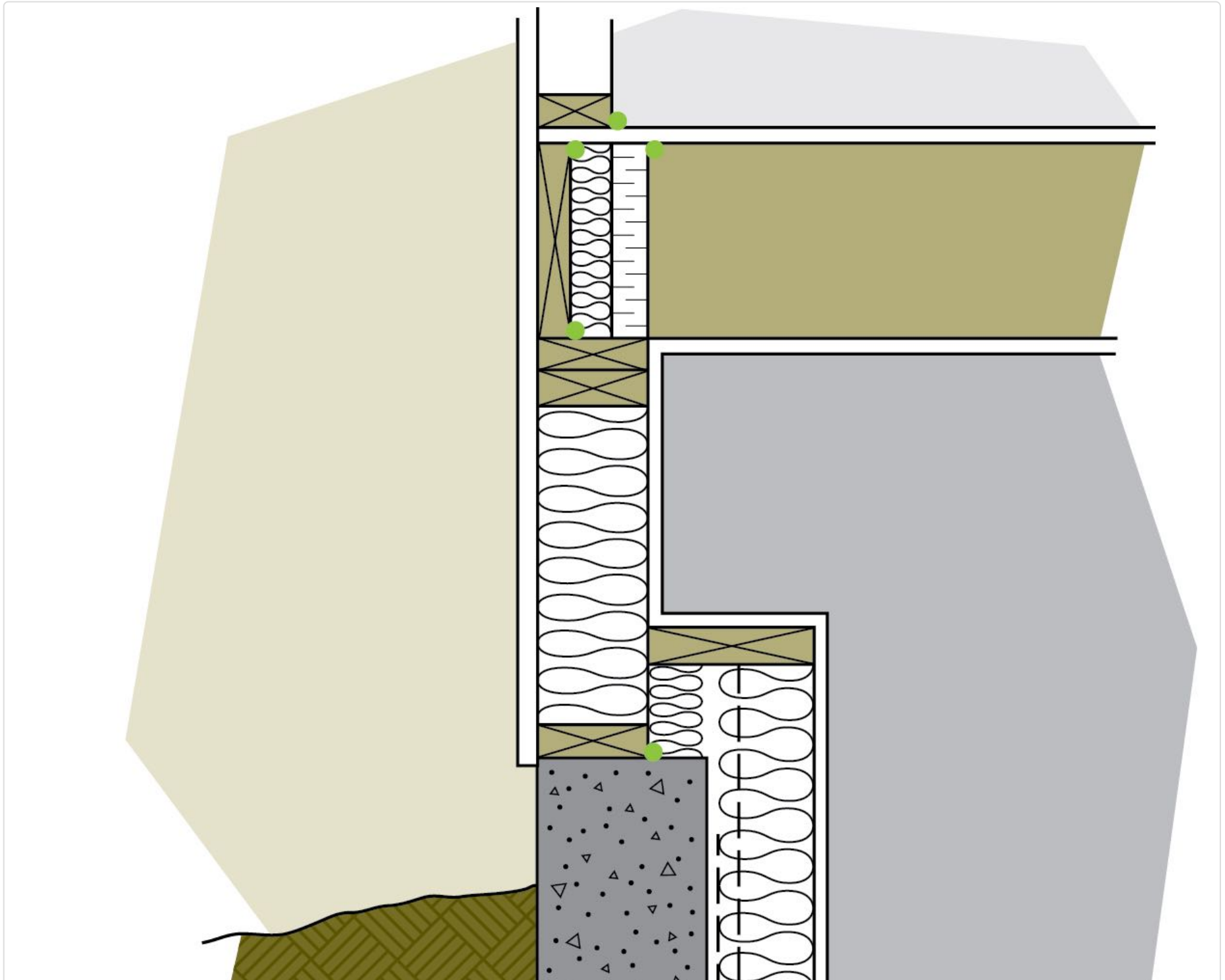

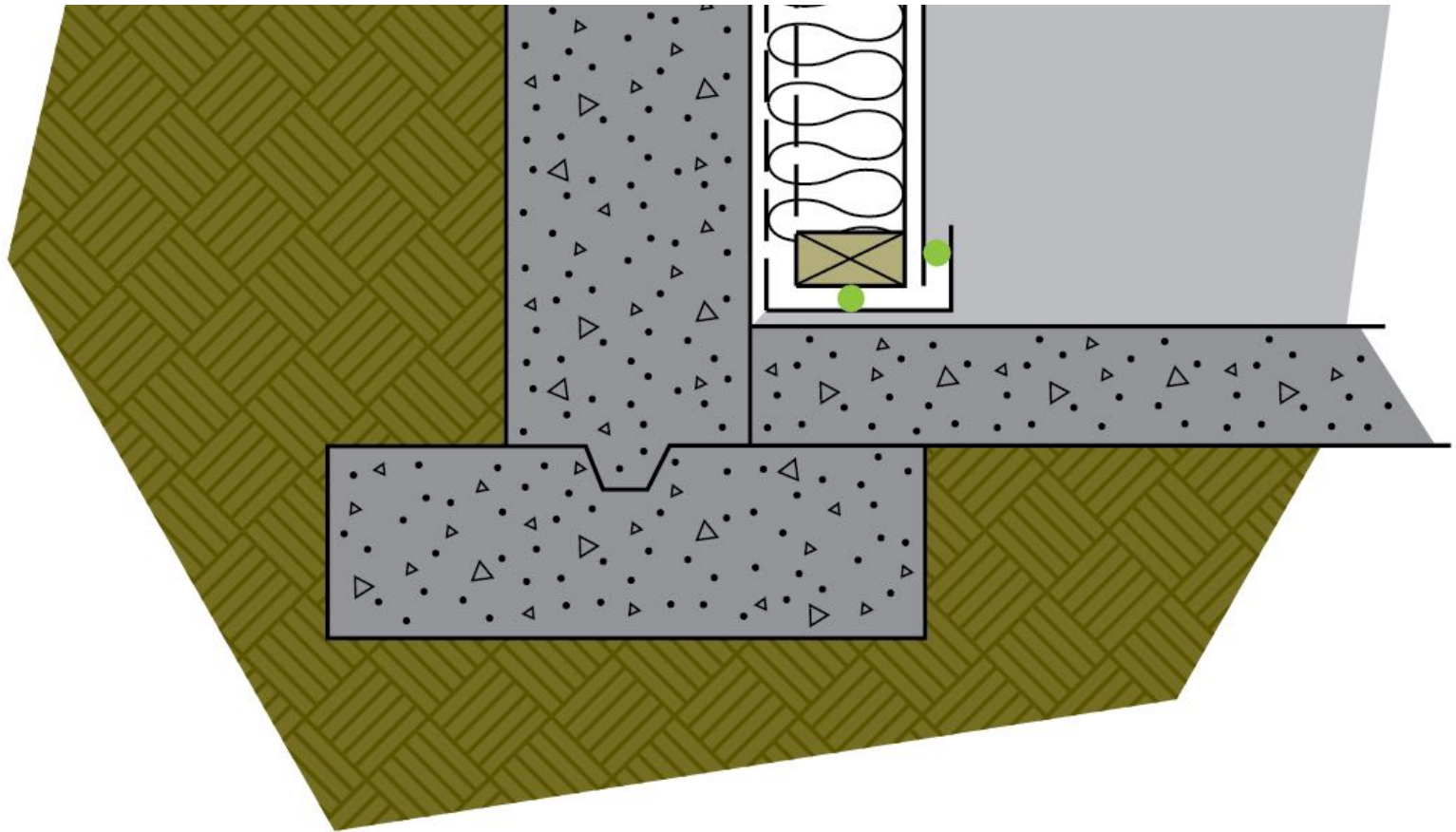

Figure 6-20 Insulating a pony wall is a two-step process that creates a small ledge

Larger image

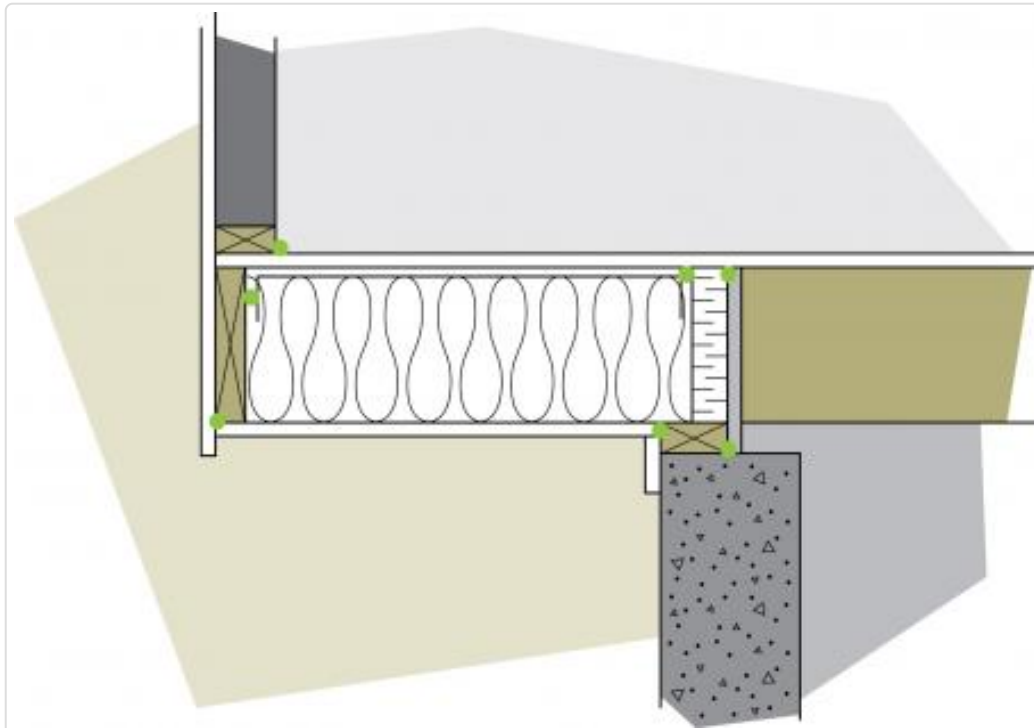

Figure 6-21 Overhangs should be air sealed before they are insulated

[Larger image](#)

- The house floor above it can be insulated to keep heat from getting into the crawl space in the first place.

As a general rule, treat heated crawl spaces as short – sometimes very short – basements and renovate them as described earlier in this chapter.

Fix any water leaks and remove sources of water infiltration as noted in Section 2.4, Control of moisture flow.

Remember, as with a basement, never vent a clothes dryer into a crawl space.

Insulating the walls is recommended to avoid having to insulate and protect all plumbing pipes and heating distribution systems. Walls can be insulated externally to reduce the internal moisture problems that can develop in damp crawl spaces and to keep the soil below the footings warm. It is also usually easier to insulate the walls than the ceiling above, especially in tight crawl spaces or

use of radiant heat (including solar-generated) in this area. Consult a heating contractor with experience in hydronic in-floor heating.

6.2.13 Uninhabited basements and crawl spaces

Medium- and high-density polyurethane foams are sometimes used in basements and crawl spaces that have poured concrete, concrete block, brick or rubble walls and are not intended to be living space. In these cases, spray foam is installed directly on the foundation wall and then sprayed with a non-flammable covering to meet local code requirements.

6.3 CRAWL SPACES

A crawl space can be insulated in two ways:

- The walls of the crawl space can be insulated on the inside or the outside, resulting in a heated area.

where joist spacing is uneven. Walls tend to require fewer materials than ceilings.

If there is no moisture barrier on the crawl space floor, add one. The minimum barrier should be 0.10 mm (4 mil) clear or opaque polyethylene overlapped, caulked and taped at the seams. Although more difficult to find, white opaque polyethylene brightens the space, shows areas of leakage or vermin entry more readily, and hides moisture or mould that may be on the other side of the plastic.

Mechanically fasten the moisture barrier to the walls and all obstructions that it cannot go over such as floor support posts. It should also be sealed to any moisture barrier added to the walls. To prevent the plastic from billowing, as may happen occasionally, hold it down with a few old boards or some smooth scrap material. If there is likely to be any traffic, protect the polyethylene with a length of plastic floor mat. Do not use sand or gravel.

6.3.1 How to insulate a heated crawl space

From the outside

- Insulate the outside wall exactly as described previously for the outside basement wall (see Figure 6-22 and Section 6.1, Insulating the basement from the outside).
- If outside obstructions (e.g. a porch or paved driveway) make it impossible to completely encircle the crawl space from outside the house, then insulate the inside portion of the wall at those points. Overlap interior and exterior insulation coverage by at least 610 mm (24 in.) See Figure 6-11.
- If the crawl space does not open into a full basement, it should have some form of ventilation. In general, do not use vents that open to the exterior, as there is a risk of condensation increasing during the summer. Instead, try to incorporate the crawl space with a whole-house ventilation approach or consider using a dehumidifier. Any existing vents should be sealed permanently if you are performing a full renovation where the space will be heated.
- If the foundation footings are above the frost line, insulate on the outside of the crawl space walls. By insulating on the outside, the walls will be kept warmer, avoiding the possibility of frost heave. Shallow footings can be kept warmer by placing a layer of horizontal insulation sloping away from the foundation.

From the inside

- If using rigid board or spray foam insulation, follow the approach as outlined for the inside of a basement (see Section 6.2, Insulating the basement from the inside). Treat joist spaces as described in Section 6.2.2, How to frame and insulate inside the basement. Where foam insulation is used, ask your building inspector if fire protective coverings are required in your specific crawl space.

- Apply a polyethylene moisture barrier to the crawl space floor and ensure the space is adequately ventilated as noted in the third bullet of Section 6.3.1, How to insulate a heated crawl space, From the outside.

6.3.2 How to insulate a partially heated crawl space

It is possible to insulate between and under the joists, and create an unheated crawl space. However, this can lead to problems of freezing pipes, frozen ground and possible rot at the joist ends. For these reasons, use floor insulation only when combined with foundation-wall insulation to create a partially heated crawl space.

Points of general importance

- The air and vapour barrier must be applied on the warm (top) side of the insulation. If the floor above the crawl space is already covered with an impermeable material (e.g. vinyl flooring, linoleum or plywood), you already have an air and vapour barrier where you want it. The solid materials of the floor can serve as the air and vapour barrier, but be sure to locate and seal any air leaks (e.g. piping and wiring holes). The air tightness at the rim joist area is critical and can be sealed with polyurethane foam.
- Batt insulation may be held in place with breathable building wrap stapled to the joists, chicken wire, sheets of polystyrene bead board (Type I or II) or a commercially available insulation-support system.
- Place the insulation tightly against the underside of the floor above, filling the joist cavity to the insulation support system.
- Tape the seams in any heating ducts and insulate all ducts and water pipes in the crawl space. Remember, even insulated water pipes may freeze if the temperature of the crawl space is allowed to fall below freezing. Consider installing energy-efficient, self-regulating electric heat trace to protect the plumbing pipes.
- Make sure that the crawl space is adequately ventilated in the spring. Vents should be installed at a ratio of 1 to 500 (vent area to floor area). Do not ventilate in winter; the vents should be plugged and insulated. Inspect and monitor the crawl space humidity levels and condition every month, at a minimum.
- There must be a moisture barrier on the crawl space floor. For full basements with a section of crawl space where a part of the floor above has been insulated, insulate the wall separating the basement from the crawl space.
- If the ground level inside the crawl space is lower than the ground level outside, there is a risk that frost heave can damage the walls by pushing them inward. Make every effort to keep water away from the foundation walls.
- As an added safety precaution, you may want to install a thermostat attached to a small heater in the crawl space. This unit can automatically prevent the crawl space from freezing.

6.4 OPEN FOUNDATIONS

Some older homes, cottages and modular/mobile homes have open foundations and exposed floors. They should be insulated between the joists in the same way as crawl spaces, with the vapour barrier placed above the insulation (always on the warm side) instead of below. There should be a good air seal and the insulation should be protected from the wind, insects and animals. It may be possible to build an insulated skirt around the foundation to create a heated crawl space.

For modular/mobile homes, the floor may contain a bagged system of insulation. It is critical to seal any perforations or openings in the system. Pay special attention to sealing the bag around the water service line, the sewer connection, gas or oil service and the combustion air inlet for the furnace.

If the joist space is already covered, consider having the floor space blown with dense-pack fibre insulation so that

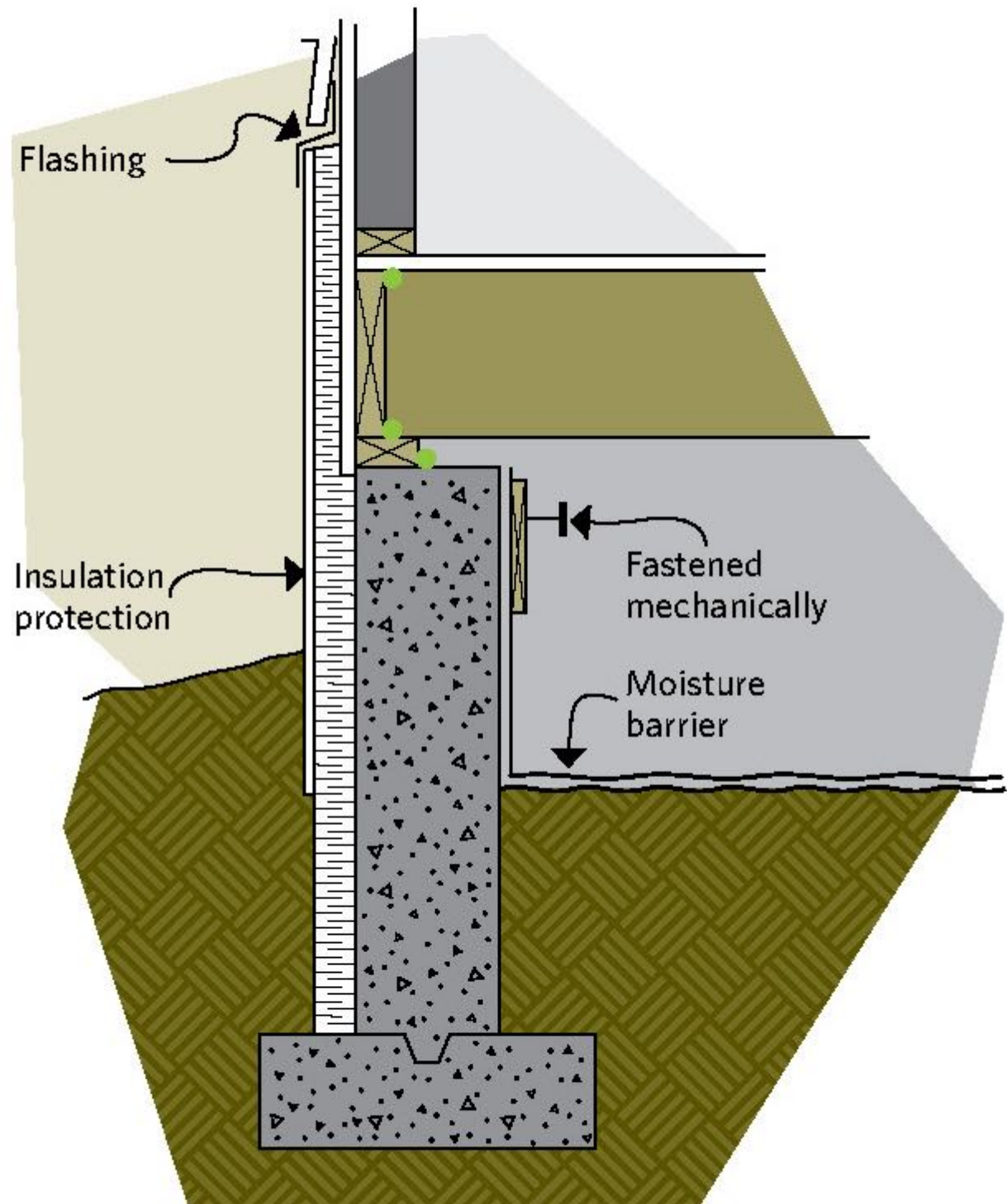

there is no air space between the insulation and the floor above. Alternatively, medium- or high-density foam can be used as the vapour barrier, air barrier and primary insulation layer.

In all cases, do not vent the clothes dryer into the floor space.



Figure 6-22 Insulating outside the crawl space is similar to insulating a full basement

[Larger image](#)

6.5 CONCRETE SLAB ON GRADE

Insulation is applied to houses with slab-on-grade foundations exactly as you would insulate the outside of a full basement (see Section 6.1, Insulating the basement from the outside). If the foundation is on frost-susceptible soils, install a layer of impermeable insulation horizontally in the soil at a slope ratio of 1:5 for at least 1 m (3 ft.). For more specific information, consult your local building authority.

Date Modified:

2016-12-02

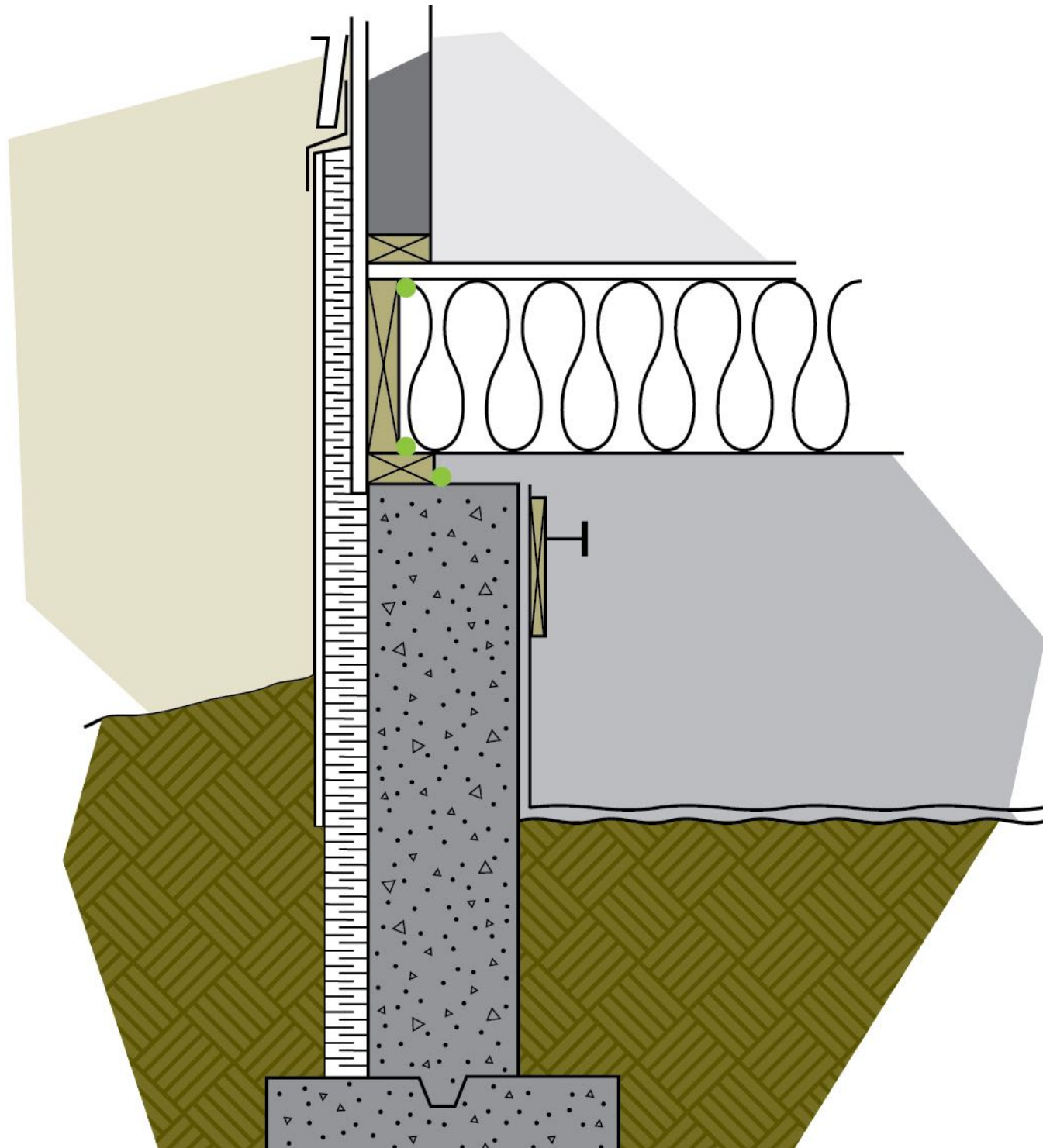

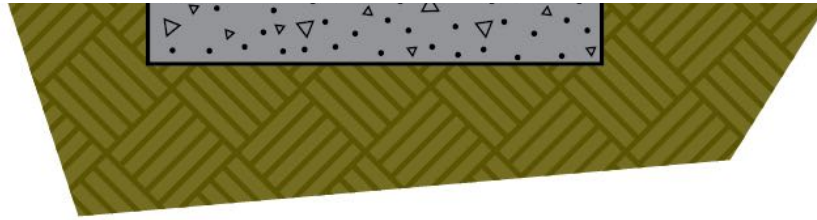

Figure 6-23 Insulation on the walls and in the floor creates a partially heated crawl space

[Larger image](#)

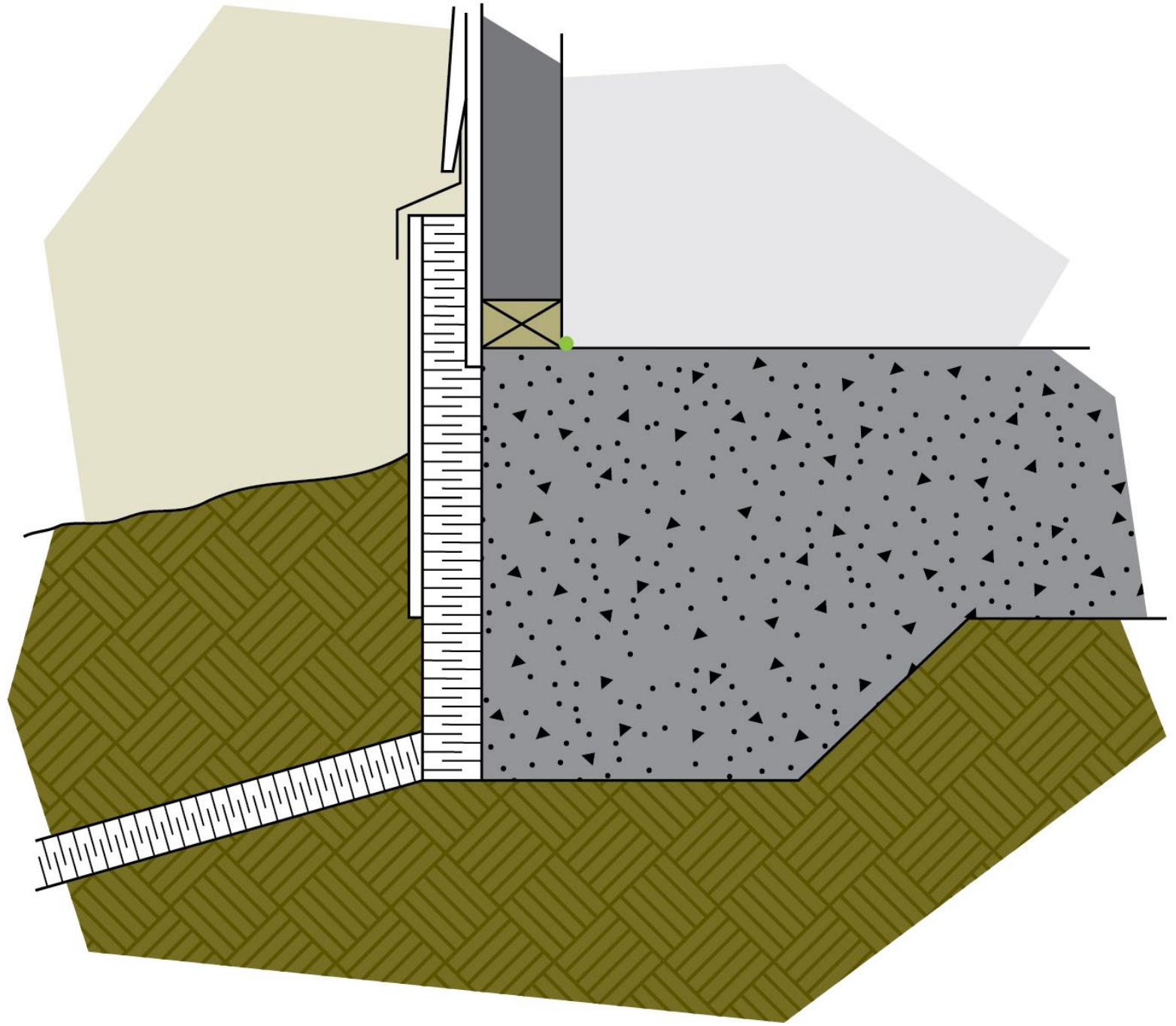

Figure 6-24 Sloped rigid insulation buried in the soil provides frost protection to the slab-on-grade

[Larger image](#)