

FRONT

BACK

WATER GAUGE & GAUGE GLASS INSTALLATION INSTRUCTIONS

INSTALLATION

Only properly trained personnel should install and maintain water gauge glass and connections. Remember to wear safety gloves and glasses during installation. Before installing, make sure all parts are free of chips and debris.

1. Apply Teflon tape or pipe dope to pipe threads. Install top gauge fitting (fitting without a drain valve) into the uppermost tapping. Wrench tighten the fitting until it is snug and the glass outlet is pointing at five o'clock (about 1/8 turn from its final downward vertical position).
2. Install the bottom gauge fitting (the fitting with a drain valve) until it is snug and the glass outlet is pointing directly upward. Verify top and bottom fittings are threaded into the tappings the same number of turns (distance A = distance B).
3. Remove glass packing nut, friction washer (or packing gland, depending upon the model), and glass packing from the fittings, and place them, in same order, on to both ends of the gauge glass. Push both packings about an inch up the gauge glass.
4. Gently insert one end of the glass into the top gauge fitting. Keeping the glass inside the top fitting, gently rotate the top gauge fitting clockwise until vertically aligned with the bottom gauge fitting, then insert glass into bottom fitting until glass bottoms out on the shoulder inside the bottom fitting.
5. Carefully raise glass about 1/16" and slide lower glass packing down until the glass packing contacts the lower gauge fitting. **DO NOT** allow the glass to remain in contact with any metal!
6. Carefully slide upper glass packing up as far as possible.
7. Hand tighten both glass packing nuts, then tighten 1/2 turn more by wrench. Tighten only enough to prevent leakage. **DO NOT OVER TIGHTEN!** If any leakage should occur, tighten slightly, a quarter turn at a time, checking for leakage after each turn.

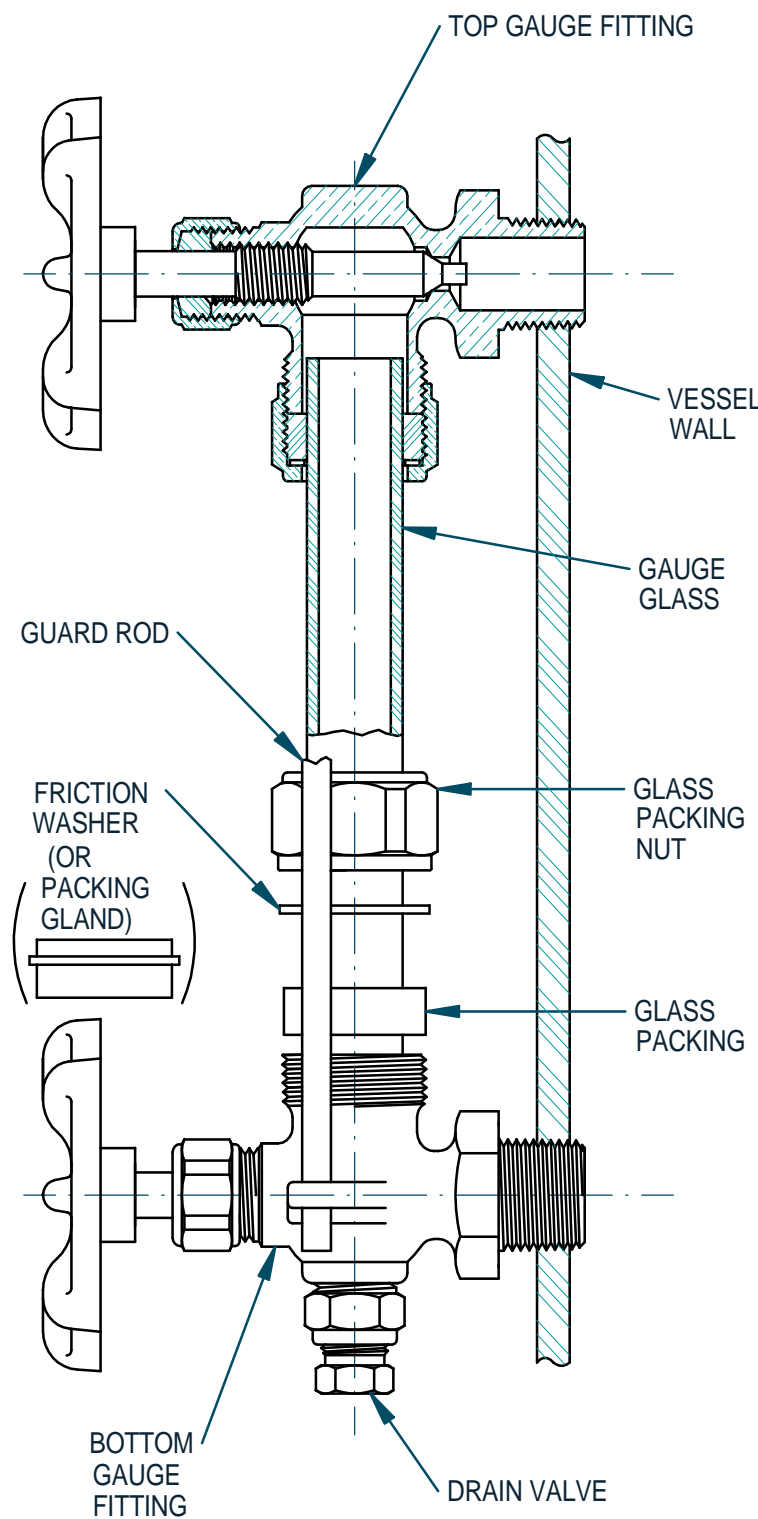

WARNING! This product contains chemicals known to the State of California to cause cancer and birth defects or other reproductive harm. (California law requires that this warning be given to the consumers in the State of California.) For more information visit www.apollovalves.com.

THIS PRODUCT MEETS THE REQUIREMENTS OF THE EPA SAFE DRINKING WATER ACT.

I-5334-00

WATER GAUGE GLASS

NOTICE:

READ ALL WARNINGS AND INSTRUCTIONS BEFORE PERFORMING INSTALLATION OR MAINTENANCE.

WARNING!

SAFETY GLASSES AND GLOVES SHOULD BE WORN AT ALL TIMES WHEN WORKING WITH OR EXAMINING WATER GAUGE GLASS AND CONNECTIONS.

IMPROPER INSTALLATION OR MAINTENANCE OF GAUGE GLASS AND CONNECTIONS CAN CAUSE IMMEDIATE OR DELAYED BREAKAGE RESULTING IN BODILY INJURY AND/OR PROPERTY DAMAGE.

USE AND CARE

DO NOT's

- DO NOT use the glass if it contains any scratches, chips, or any other visible signs of damage.
- DO NOT reuse any tubular glass or glass packings.
- DO NOT subject gauge glass to bending or torsional stresses.
- DO NOT over tighten glass packing nuts.
- DO NOT allow glass to touch any metal parts.
- DO NOT exceed the recommended pressure of the gauge or gauge glass.
- DO NOT clean the gauge or gauge glass while pressurized or in operation.



Made In The USA
 Manufactured by Conbraco Industries, Inc.
 1418 S. PEARL ST.
 PAGELAND, SC 29728
 TELEPHONE (704) 841-6000
www.apollovalves.com

WATER GAUGE GLASS

DO's

- DO verify proper gauge has been supplied.
- DO examine gauge glass and packings carefully for damage before installation.
- DO install protective guards and utilize automatic ball checks where necessary to help prevent injury in case of glass breakage.
- DO inspect the gauge glass daily, keep maintenance records, and conduct routine replacements.
- DO protect glass from sudden changes in temperatures such as drafts, water spray, etc.

MAINTENANCE

Examine the gauge glass regularly for any signs of clouding, scratching, erosion, or corrosion. The glass should be inspected daily until the need for replacement becomes apparent. This will help establish the routine inspection and routine replacement schedules.

CLEANING

Use commercial non-abrasive glass cleaners to keep the glass clean. Use diluted acids such as Hydrochloric (muriatic) acid when regular cleaners do not seem to work. Do not use wire brushes or any other abrasive materials which could scratch the glass.

INSPECTION

Examine the surface of the glass for scratches, corrosion, chips, cracks, surface flaws, or nicks. To do this, shine a very bright concentrated light at an angle of about 45 degrees. A defective glass will glisten as the light strikes imperfections. Glass which appears cloudy or roughened, and will not respond to cleaning, should be replaced.

STORING

Keep gauge glass in original packaging until ready to install.

I-5334-00