



# EXTROL®

## EXPANSION TANKS FOR HYDRONIC HEATING & CHILLED WATER SYSTEMS

### INSTALLATION & OPERATION INSTRUCTIONS

Models EX-15 through EX-90  
Models SX-30V through SX-160V



CLICK ANYWHERE on THIS PAGE to RETURN to EXPANSION TANK GUIDES at [InspectApedia.com](http://InspectApedia.com)

**NOTE:** Inspect for shipping damage. Notify freight carrier or store where purchased immediately if damage is present. To avoid risk of personal injury and property damage, if the product appears to be malfunctioning or shows signs of corrosion, call a qualified professional immediately. Current copies of the product manual can be viewed at [www.amtrol.com](http://www.amtrol.com). Use proper safety equipment when installing.



**THIS IS THE SAFETY ALERT SYMBOL. IT IS USED TO ALERT YOU TO POTENTIAL PERSONAL INJURY AND OTHER HAZARDS. OBEY ALL SAFETY MESSAGES THAT FOLLOW THIS SYMBOL TO REDUCE THE RISK OF PERSONAL INJURY AS WELL AS PROPERTY DAMAGE.**

**WARNING** USE ONLY IN RESIDENTIAL CLOSED HYDRONIC SYSTEMS. Do not install on domestic water systems, or in open heating systems. Corrosion and tank failure may result. Use a Therm-X-Trol® or Therm-X-Span® for domestic water systems. Use a Radiant EXTROL® for radiant heating systems where air elimination equipment or barrier tubing is not used.

**WARNING** READ CAREFULLY THE PRODUCT INSTALLATION, OPERATING AND MAINTENANCE MANUAL. FAILURE TO FOLLOW THE INSTRUCTIONS AND WARNINGS IN THE MANUAL MAY RESULT IN SERIOUS OR FATAL INJURY AND/OR PROPERTY DAMAGE, AND WILL VOID THE PRODUCT WARRANTY. THIS PRODUCT MUST BE INSTALLED BY A QUALIFIED PROFESSIONAL. FOLLOW ALL APPLICABLE LOCAL AND STATE CODES AND REGULATIONS, IN THE ABSENCE OF SUCH CODES, FOLLOW THE CURRENT EDITIONS OF THE NATIONAL PLUMBING CODE AND NATIONAL ELECTRIC CODE, AS APPLICABLE.

**WARNING** This Product, like most Products under pressure, may over time corrode, weaken and burst or explode, causing serious or fatal injury, leaking or flooding and/or property damage. To minimize risk, a licensed professional must install and periodically inspect and service the Product. A drip pan connected to an adequate drain must be installed if leaking or flooding could cause property damage. Do not locate in an area where leaking could cause property damage to the area adjacent to the appliance or to lower floors of the structure.

**CALIFORNIA PROPOSITION 65 WARNING!** This product contains a chemical known by the State of California to cause cancer and to cause birth defects or other reproductive harm. (California Installer/Contractor - California law requires that this notice be given to consumer/end user of this product.) For more information: [www.amtrol.com/prop65.html](http://www.amtrol.com/prop65.html)

**WARNING** RUPTURE OR EXPLOSION HAZARD. Do not expose product to freezing temperatures or temperatures in excess of 240°F. Do not adjust the pre-charge or re-charge this Product except during installation or regular inspection. Replace the Product and do not adjust the pre-charge if corroded, damaged or with diminished integrity. Adjustments to pre-charge must be done at ambient temperature only. Failure to properly size the Product or follow these instructions may result in excessive strain on the system and may lead to Product failure, serious or fatal personal injury, leakage, and/or property damage.

**WARNING** A relief valve must be installed to prevent pressure in excess of local code requirement or maximum working pressure designated in the Product Manual, whichever is less. At least once every 3 years or if discharge is present, a licensed contractor should inspect the pressure relief valve and replace if corrosion is evident or the valve does not function. **FAILURE TO INSPECT THIS VALVE AS DIRECTED COULD RESULT IN UNSAFE PRESSURE BUILD-UP WHICH CAN RESULT IN PRODUCT FAILURE, SERIOUS INJURY OR DEATH AND/OR SEVERE PROPERTY DAMAGE AND VOID THE PRODUCT WARRANTY.**

**WARNING** Chlorine & Aggressive Water: The water quality can significantly influence the life of this Product. You should test for corrosive elements, acidity, total solids and other relevant contaminants, including chlorine and treat your water appropriately to insure satisfactory performance and prevent premature failure.

**PLEASE READ THE FOLLOWING INSTRUCTIONS CAREFULLY FOR  
IMPORTANT GENERAL SAFETY INFORMATION AND ADDITIONAL SPECIFIC SAFETY ALERTS.  
VISIT [www.amtrol.com](http://www.amtrol.com) TO VIEW HELPFUL VIDEOS.**

**Pre-Installation**

1. Visually inspect for any damage. Ensure expansion tank is sized properly for the application (Figure 1).
2. With tank empty of water, remove plastic cap from air stem (Figure 2).
3. Check precharge pressure and adjust if necessary, charging with air to match boiler fill valve setting.
4. Replace cap and tighten snugly, ensuring the cap is flush against the tank surface.

**Figure 1.**

Boiler Net Output in 1000'S of BTU/Hr.	Type of Radiation			
	Finned Tube Baseboard or Radiant Panel	Convectors or Unit Heaters	Radiators Cast Iron	Baseboard Cast Iron
25	EX-15	EX-15	EX-15	EX-15
50	EX-15	EX-15	EX-30	EX-30
75	EX-30	EX-30	EX-30	EX-60
100	EX-30	EX-30	EX-60	EX-60
125	EX-30	EX-60	EX-60	EX-90
150	EX-30	EX-60	EX-90	EX-90
175	EX-60	EX-60	EX-90	EX-90
200	EX-60	EX-60	EX-90	EX-90
250	EX-60	EX-90	EX-90	EX-90
300	EX-90	SX-30V	SX-30V	SX-40V
350	SX-30V	SX-30V	SX-40V	SX-60V
400	SX-30V	SX-40V	SX-40V	SX-60V
450	SX-40V	SX-40V	SX-60V	SX-90V
500	SX-40V	SX-40V	SX-60V	SX-90V
550	SX-40V	SX-60V	SX-60V	SX-90V
600	SX-40V	SX-60V	SX-90V	SX-90V
650	SX-60V	SX-60V	SX-90V	SX-90V
700	SX-60V	SX-60V	SX-90V	SX-90V
750	SX-60V	SX-60V	SX-90V	SX-110V
800	SX-60V	SX-90V	SX-90V	SX-110V
850	SX-60V	SX-90V	SX-90V	SX-110V
900	SX-60V	SX-90V	SX-110V	SX-110V
950	SX-90V	SX-90V	SX-110V	SX-110V
1,000	SX-90V	SX-90V	SX-110V	SX-110V
1,100	SX-90V	SX-90V	SX-110V	SX-130V
1,200	SX-90V	SX-90V	SX-110V	SX-130V
1,300	SX-90V	SX-110V	SX-130V	SX-160V
1,400	SX-110V	SX-130V	SX-160V	SX-160V
1,500	SX-110V	SX-130V	SX-160V	(2)SX-110V

*Sizing based on: 12 psig Fill; 30 psig Relief Valve; 200°F Average Temperature.*

**Figure 2.**

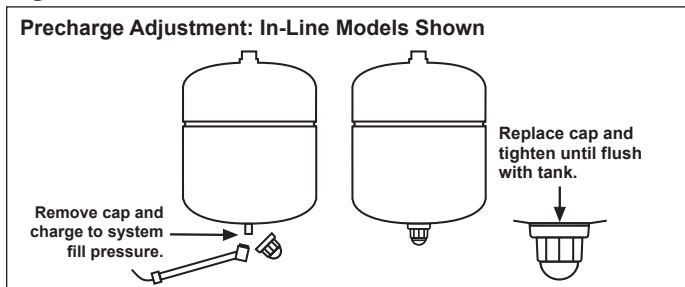

**WARNING** FAILURE TO PROPERLY SEAL CAP WILL RESULT IN LOSS OF PRECHARGE CAUSING PRODUCT TO FAIL.

**WARNING** Mount tank vertically in downward position only. Ensure the piping can support the entire weight of the tank when full of water.

**WARNING** Models SX-30V through SX-160V are floor standing and may not be hung from the piping.

**WARNING** Do not install the EXTROL on a dead-end pipe or wherever air can collect. This can cause corrosion and possible leakage.

**Installation**

1. Drain the boiler system or isolate the area where the EXTROL will be installed.
2. Install the EXTROL on the supply side of the boiler, on the suction-side of the heating circulator(s) (Figure 3).
3. Pressurize the system and check for leaks. Repair as necessary.
4. Restart the boiler system and check for relief valve discharge. If the relief valve drips, the tank may be improperly charged or undersized.

**Figure 3.**

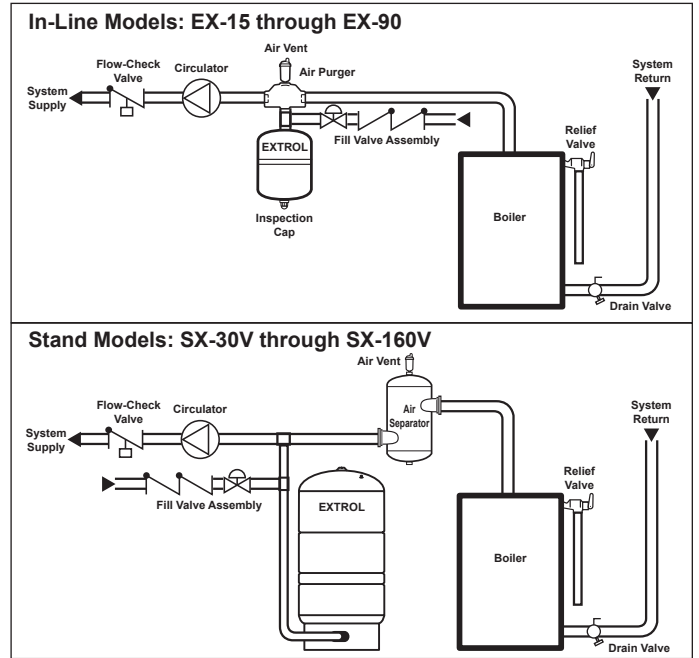

**Maintenance**

A professional plumber should check the complete system, including the expansion tank, yearly and more frequently as the system ages. Checking the precharge allows a small quantity of air to escape and can result in an insufficient air charge. Always check the precharge while the tank is isolated and empty of water, and be sure to maintain the proper precharge whenever the tank is inspected. Monitor the tip of the inspection cap for discoloration (Figure 4) in addition to regular product inspection. Contact the installer or a plumbing professional if inspection cap is discolored; tank replacement required. Do not rely on cap as sole indication of tank condition.

**Figure 4.**

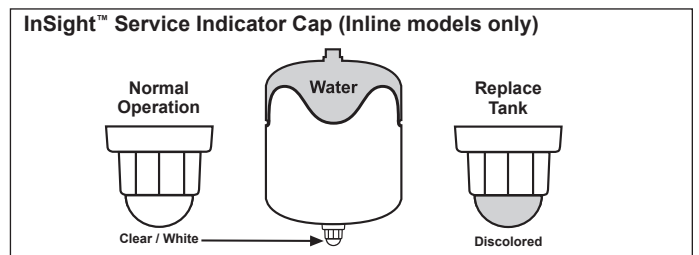

**Warranty**

EX Models: Five (5) Year Limited Warranty  
 SX Models: One (1) Year Limited Warranty  
 Visit [www.amtrol.com](http://www.amtrol.com) for complete warranty details.



1400 Division Road, West Warwick, RI USA 02893  
 T: 800.426.8765 F: 800.293.1519

[www.amtrol.com](http://www.amtrol.com)

