



Installation Guidelines

7 kW PowerPact™ Generator

⚠ DANGER!



**NOT INTENDED FOR USE IN CRITICAL
LIFE SUPPORT APPLICATIONS.**



**ONLY QUALIFIED ELECTRICIANS OR
CONTRACTORS SHOULD ATTEMPT
INSTALLATION!**



**DEADLY EXHAUST FUMES! OUTDOOR
INSTALLATION ONLY!**

This manual should remain with the unit.

**This manual must be used in conjunction
with the appropriate owner's manual.**

To locate in Spanish, go to <http://www.generac.com/service-support/product-support-lookup>

To locate in French, go to <http://www.generac.com/service-support/product-support-lookup>

WARNING!

California Proposition 65

Engine exhaust and some of its constituents are known to the state of California to cause cancer, birth defects, and other reproductive harm.

WARNING!

California Proposition 65

This product contains or emits chemicals known to the state of California to cause cancer, birth defects, and other reproductive harm.

Table of Contents

Section 1 Safety and General Information

1.1 Introduction	1
1.1.1 Read This Manual Thoroughly	1
1.1.2 How to Obtain Service	2
1.2 Safety Rules	2
1.2.1 General Hazards	2
1.2.2 Electrical Hazards	3
1.2.3 Fire Hazards	3
1.2.4 Explosion Hazards	4
1.3 General Rules	4
1.3.1 Before You Begin	4
1.3.2 NEC Requirements	4
1.3.3 Standards Index	5

Section 2 Unpacking and Inspection

2.1 General	7
2.2 Required Tools	7
2.3 Unpacking	7
2.4 Parts Shipped Loose	9

Section 3 Site Selection and Preparation

3.1 Site Selection	11
3.1.1 Installation Guidelines	12
3.2 Site Preparation	13
3.2.1 Material Sufficient for Level Installation	14
3.2.2 Transportation Recommendations	15

Section 4 Generator Placement

4.1 Generator	17
----------------------	-----------

Section 5 Fuel Conversion/Gas Connections

5.1 Fuel Conversion	19
5.2 Fuel Requirements and Recommendations	20
5.3 Fuel Consumption	20
5.4 Fuel Line Sizing	21
5.4.1 Natural Gas Pipe Sizing	21
5.4.2 LP Vapor Pipe Sizing	21
5.4.3 Gas Installation Summary	21
5.5 Installing and Connecting Gas Lines	22

Section 6 Electrical Connections

6.1 Control Wiring27
 6.2 Main AC Wiring28
 6.3 Battery Requirements29
 6.4 Battery Installation29

Section 7 Installation Checks and Tests

7.1 Control Panel Interface31
 7.1.1 Using Auto/Manual/Off/Set Exercise Buttons31
 7.2 Before Initial Start-Up32
 7.3 Generator Activation32
 7.3.1 Activation Sequence32
 7.3.2 Before Starting32
 7.3.3 Setting Exercise Timer33
 7.4 Check Manual Transfer Switch Operation33
 7.5 Electrical Checks33
 7.6 Generator Tests Under Load34
 7.7 Checking Automatic Operation35
 7.8 Installation Summary35

Section 8 Troubleshooting

8.1 Troubleshooting Guide37

Section 9 Quick Reference Guide

9.1 System Diagnosis39

Section 10 Accessories

10.1 Descriptions41

Section 11 Diagrams

11.1 Installation Diagram43
 11.2 Wiring Diagram45

Section 1 Safety and General Information

1.1 — Introduction

Thank you for purchasing this compact, high performance, air-cooled, engine-driven generator. It is designed to automatically supply electrical power to operate critical loads during a utility power failure.

This unit is factory installed in an all-weather, metal enclosure that is intended exclusively for outdoor installation. This generator will operate using either vapor withdrawn liquid propane (LP) or natural gas (NG).

NOTE: When sized properly, this generator is suitable for supplying typical residential loads such as Induction Motors (sump pumps, refrigerators, air conditioners, furnaces, etc.), Electronic Components (computer, monitor, TV, etc.), Lighting Loads and Microwaves.

1.1.1— Read This Manual Thoroughly

If any portion of this manual is not understood, contact the nearest Dealer for starting, operating and servicing procedures.

Throughout this publication and on tags and decals affixed to the generator, DANGER, WARNING, CAUTION and NOTE blocks are used to alert personnel to special instructions about a particular operation that may be hazardous if performed incorrectly or carelessly. Observe them carefully. Their definitions are as follows:

DANGER!

Indicates a hazardous situation or action that, if not avoided, will result in death or serious injury.

WARNING!

Indicates a hazardous situation or action that, if not avoided, could result in death or serious injury.

CAUTION!

Indicates a hazardous situation or action that, if not avoided, could result in minor or moderate injury.

NOTE: Notes provide additional information important to a procedure or component.

These safety warnings cannot eliminate the hazards they indicate. Observing safety precautions and strict compliance with the special instructions while performing the action or service are essential to preventing accidents.

Four commonly used safety symbols accompany DANGER, WARNING, and CAUTION boxes and the type of information each indicates:



This symbol points out important safety information that, if not followed, could endanger personnel and/or property.



This symbol represents the potential for an Explosion Hazard.



This symbol represents the potential for a Fire Hazard.



This symbol represents the potential for an Electrical Shock Hazard.

The operator is responsible for proper and safe use of the equipment. The manufacturer strongly recommends that if the operator is also the owner, to read their Owner's Manual and thoroughly understand all instructions before using this equipment. The manufacturer also strongly recommends instructing other users to properly start and operate the unit. This prepares them if they need to operate the equipment in an emergency.

1.1.2— How to Obtain Service

When the generator requires servicing or repairs, contact a Dealer for assistance. Service technicians are factory-trained and are capable of handling all service needs. For assistance locating a dealer, call 1-888-436-3722.

When contacting a Dealer about parts and service, always supply the complete model number and serial number of the unit as given on its data decal, which is located on the generator. See section “The Generator” for decal location.

Model No. _____ Serial No. _____

1.2 — Safety Rules

⚠ WARNING!

⚠ Save These Instructions – The manufacturer suggests that these rules for safe operation be copied and posted near the unit’s installation site. Safety should be stressed to all operators and potential operators of this equipment.

Study these SAFETY RULES carefully before installing, operating or servicing this equipment. Become familiar with this Installation Manual and with the unit. The generator can operate safely, efficiently and reliably only if it is properly installed, operated and maintained. Many accidents are caused by failing to follow simple and fundamental rules or precautions.

The manufacturer cannot anticipate every possible circumstance that might involve a hazard. The warnings in this manual and on tags and decals affixed to the unit are, therefore, not all-inclusive. If using a procedure, work method or operating technique the manufacturer does not specifically recommend, ensure that it is safe for others. Also, make sure the procedure, work method or operating technique utilized does not render the generator unsafe.

⚠ DANGER!

⚠ Despite the safe design of this generator, operating this equipment imprudently, neglecting its maintenance or being careless can cause possible injury or death. Permit only responsible and capable persons to install, operate and maintain this equipment.

⚠ Potentially lethal voltages are generated by these machines. Ensure all steps are taken to render the machine safe before attempting to work on the generator.

⚠ Parts of the generator are rotating and/or hot during operation. Exercise care near running generators.

⚠ Installation must always comply with applicable codes, standards, laws and regulations.

⚠ A running generator gives off carbon monoxide, an odorless, colorless poison gas. Breathing in carbon monoxide can cause headaches, fatigue, dizziness, nausea, vomiting, confusion, fainting, seizures or death.

1.2.1— General Hazards

- For safety reasons, the manufacturer recommends that this equipment be installed by a Service Dealer or other competent, qualified electrician or installation technician who is familiar with applicable codes, standards and regulations. The operator also must comply with all such codes, standards and regulations. Only an Authorized Service Dealer is allowed to perform warranty service on this unit.
- The engine exhaust fumes contain carbon monoxide, which can be DEADLY. This dangerous gas, if breathed in sufficient concentrations, can cause unconsciousness or even death. Do NOT alter or add to the exhaust system or do anything that might render the system unsafe or in noncompliance with applicable codes and standards.
- Install a battery-operated carbon monoxide alarm indoors, according to manufacturer’s instructions/recommendations.

- Adequate, unobstructed flow of cooling and ventilating air is critical to correct generator operation. Do not alter the installation or permit even partial blockage of ventilation provisions, as this can seriously affect safe operation of the generator. The generator **MUST** be installed and operated outdoors only.
- Keep hands, feet, clothing, etc., away from drive belts, fans, and other moving or hot parts. Never remove any drive belt or fan guard while the unit is operating.
- When working on this equipment, remain alert at all times. Never work on the equipment when physically or mentally fatigued.
- Inspect the generator regularly, and contact the nearest Dealer for parts needing repair or replacement.
- Before performing any maintenance on the generator, disconnect its battery cables to prevent accidental start up. Disconnect the cable from the battery post indicated by a **NEGATIVE**, **NEG** or **(-)** first, then remove the **POSITIVE**, **POS** or **(+)** cable. When reconnecting the cables, connect the **POSITIVE** cable first, the **NEGATIVE** cable last.
- Never use the generator or any of its parts as a step. Stepping on the unit can stress and break parts, and may result in dangerous operating conditions from leaking exhaust gases, fuel leakage, oil leakage, etc.

1.2.2— Electrical Hazards

- All generators covered by this manual produce dangerous electrical voltages and can cause fatal electrical shock. Utility power delivers extremely high and dangerous voltages to the transfer switch, as does the standby generator when it is in operation. Avoid contact with bare wires, terminals, connections, etc., while the unit is running. Ensure all appropriate covers, guards and barriers are in place, secured and/or locked before operating the generator. If work must be done around an operating unit, stand on an insulated, dry surface to reduce shock hazard.
- Do not handle any kind of electrical device while standing in water, while barefoot, or while hands or feet are wet. **DANGEROUS ELECTRICAL SHOCK MAY RESULT.**
- The National Electrical Code (NEC) requires the frame and external electrically conductive parts of the generator to be connected to an approved earth ground. Local electrical codes also may require proper grounding of the generator electrical system.
- After installing this home standby electrical system, the generator may crank and start at any time without warning. When this occurs, load circuits are transferred to the **STANDBY** (generator) power source. To prevent possible injury if such a start and transfer occur, always set the generator to the **OFF** mode, remove the 7.5A fuse from the generator control panel, and disconnect the battery before working on equipment.
- In case of accident caused by electric shock, immediately shut down the source of electrical power. If this is not possible, attempt to free the victim from the live conductor. **AVOID DIRECT CONTACT WITH THE VICTIM.** Use a nonconducting implement, such as a dry rope or board, to free the victim from the live conductor. If the victim is unconscious, apply first aid and get immediate medical help.
- Never wear jewelry when working on this equipment. Jewelry can conduct electricity resulting in electric shock, or may get caught in moving components causing injury.

1.2.3— Fire Hazards

- For fire safety, the generator must be installed and maintained properly. Installation must always comply with applicable codes, standards, laws and regulations. Adhere strictly to local, state and national electrical and building codes. Comply with regulations the Occupational Safety and Health Administration (OSHA) has established. Also, ensure that the generator is installed in accordance with the manufacturer's instructions and recommendations. Following proper installation, do nothing that might alter a safe installation and render the unit in noncompliance with the aforementioned codes, standards, laws and regulations.
- Keep a fire extinguisher near the generator at all times. Extinguishers rated "ABC" by the National Fire Protection Association are appropriate for use on the standby electric system. Keep the extinguisher properly charged and be familiar with its use. Consult the local fire department with any questions pertaining to fire extinguishers.

1.2.4— Explosion Hazards

- Do not smoke around the generator. Wipe up any fuel or oil spills immediately. Ensure that no combustible materials are left in the generator compartment, or on or near the generator, as FIRE or EXPLOSION may result. Keep the area surrounding the generator clean and free from debris.
- Gaseous fluids such as natural gas and liquid propane (LP) gas are extremely EXPLOSIVE. Install the fuel supply system according to applicable fuel-gas codes. Before placing the home standby electric system into service, fuel system lines must be properly purged and leak tested according to applicable code. After installation, inspect the fuel system periodically for leaks. No leakage is permitted.

1.3 — General Rules

- Follow all safety precautions in the Owner's Manual, Installation Guidelines manual and other documents included with your equipment.
- Refer to NFPA 70E for safety equipment required when working with a live system.
- Never energize a new system without opening all disconnects and breakers.
- Always consult your local code for additional requirements for the area in which the unit is being installed.

⚠ WARNING!

 **Improper installation can result in personal injury and damage to the generator. It may also result in the warranty being suspended or voided. All the instructions listed below must be followed including location clearances and pipe sizes.**

1.3.1— Before You Begin

- Contact the local inspector or City Hall to be aware of all federal, state and local codes that could impact the installation. Secure all required permits before starting the job.
- Carefully read and follow all of the procedures and safety precautions detailed in the installation guide. If any portion of the installation manual, technical manual or other factory-supplied documents is not completely understood, contact a dealer for assistance.
- Fully comply with all relevant NEC, NFPA and OSHA standards as well as all federal, state and local building and electric codes. As with any generator, this unit must be installed in accordance with current NFPA 37 and NFPA 70 standards as well as any other federal, state, and local codes for minimum distances from other structures.
- Verify the capacity of the natural gas meter or the LP tank in regards to providing sufficient fuel for both the generator and other household and operating appliances.

1.3.2— NEC Requirements

Local code enforcement may require that Arc Fault Circuit Interrupters (AFCIs) be incorporated into the transfer switch distribution panel. The Transfer Switch provided with this generator has a distribution panel that will accept AFCIs (pre-wired transfer switches only).

Siemens Part No. Q115AF - 15A or Q120AF - 20A can be obtained from a local electrical wholesaler and will simply replace any of the single pole circuit breakers supplied in the pre-wired transfer switch distribution panel.

1.3.3— Standards Index

NOTE: DO NOT use this generator in critical life support applications.

Strictly comply with all applicable national, state and local laws, as well as codes or regulations pertaining to the installation of this engine-generator power system. Use the most current version of applicable codes or standards relevant to the local jurisdiction, generator used, and installation site.

NOTE: Not all codes apply to all products and this list is not all-inclusive. In the absence of pertinent local laws and standards, the following publications may be used as a guide (these apply to localities which recognize NFPA and IBC).

1. National Fire Protection Association (NFPA) 70: The NATIONAL ELECTRIC CODE (NEC) *
2. NFPA 10: Standard for Portable Fire Extinguishers *
3. NFPA 30: Flammable And Combustible Liquids Code *
4. NFPA 37: Standard for Stationary Combustion Engines And Gas Turbines *
5. NFPA 54: National Fuel Gas Code *
6. NFPA 58: Standard for Storage And Handling Of Liquefied Petroleum Gases *
7. NFPA 68: Standard On Explosion Protection By Deflagration Venting *
8. NFPA 70E: Standard For Electrical Safety In The Workplace *
9. NFPA 99: Health Care Facilities Code *
10. NFPA 220: Standard on Types of Building Construction *
11. NFPA 5000: Building Code *
12. International Building Code **
13. Agricultural Wiring Handbook ***
14. ASAE EP-364.2 Installation and Maintenance of Farm Standby Electric Power ****

This list is not all-inclusive. Check with the Authority Having Local Jurisdiction (AHJ) for any local codes or standards which may be applicable to your jurisdiction. The above listed standards are available from the following internet sources:

* www.nfpa.org

** www.iccsafe.org

*** www.nerc.org Rural Electricity Resource Council P.O. Box 309 Wilmington, OH 45177-0309

**** www.asabe.org American Society of Agricultural & Biological Engineers 2950 Niles Road, St. Joseph, MI 9085

⚠ DANGER!



The installation of this product must comply strictly with applicable codes, standards and regulations. This product can be installed by the homeowner. However, if you are uncomfortable with the skills or tools required, have a qualified electrician or contractor perform the installation.

⚠ DANGER!



If this generator is used to power electrical load circuits normally powered by a utility power source, it is required by code to install a transfer switch. The transfer switch must effectively isolate the electrical system from the utility distribution system when the generator is operating (NEC 702). Failure to isolate an electrical system by such means will result in damage to the generator and also may result in injury or death to utility power workers due to backfeed of electrical energy.

This page intentionally left blank.

Section 2 *Unpacking and Inspection*

2.1 — General

NOTE: After unpacking, carefully inspect the contents for damage. It is advised to unpack and inspect the unit immediately upon delivery to detect any damage that may have occurred in transit. Any claims for shipping damage need to be filed as soon as possible with the freight carrier. This is especially important if the generator will not be installed for a period of time.

- This standby generator set is ready for installation and has a weather protective enclosure that is intended for outdoor installation only.
- This UL listed standby generator set may be packaged with an automatic transfer switch with built-in load center. The combination transfer switch and load center may be pre-wired with a two foot and 30 foot conduit. The pre-wired switch is rated for indoor use only. Circuit breakers for emergency circuit connections are included.
- This UL listed, 2-pole switch is rated at 30 amps, rated at 250 volts maximum.
- If any loss or damage is noted at time of delivery, have the person(s) making the delivery note all damage on the freight bill or affix their signature under the consignor's memo of loss or damage.
- If a loss or damage is noted after delivery, separate the damaged materials and contact the carrier for claim procedures.
- "Concealed damage" is understood to mean damage to the contents of a package that is not evident at the time of delivery, but is discovered later.

2.2 — Required Tools

- General SAE and Metric hand tools
 - Wrenches
 - Sockets
 - Screwdrivers
- Standard electrician's hand tools
 - Drill and bits for mounting and routing conduits
- Pliers
- Needle Nose Pliers (for fuel conversion)
- 4mm and 6mm Allen wrench
- 3/16 Allen wrench (test port on fuel regulator)
- Manometer (for fuel pressure checks)
- Meter capable of measuring AC/DC Voltage and Frequency

2.3 — Unpacking

1. With the box removed, you can see the transfer switch (if equipped). The transfer switch is an option and may not be included.
2. Remove the wood frame and lift the transfer switch, if present, off the top of the generator.

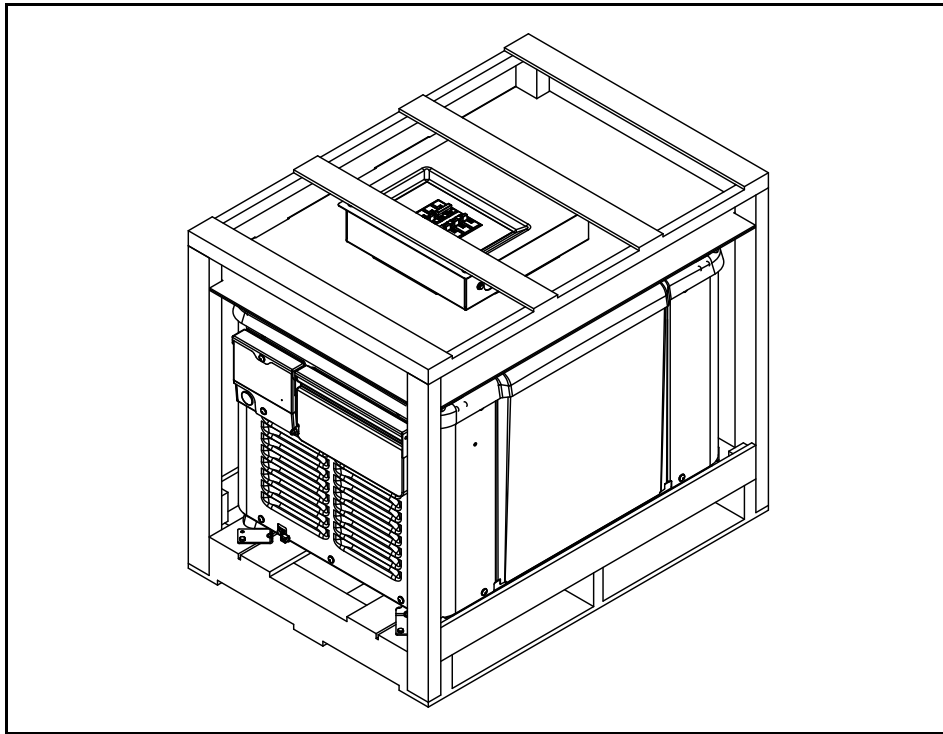

Figure 2-1. Crated Generator

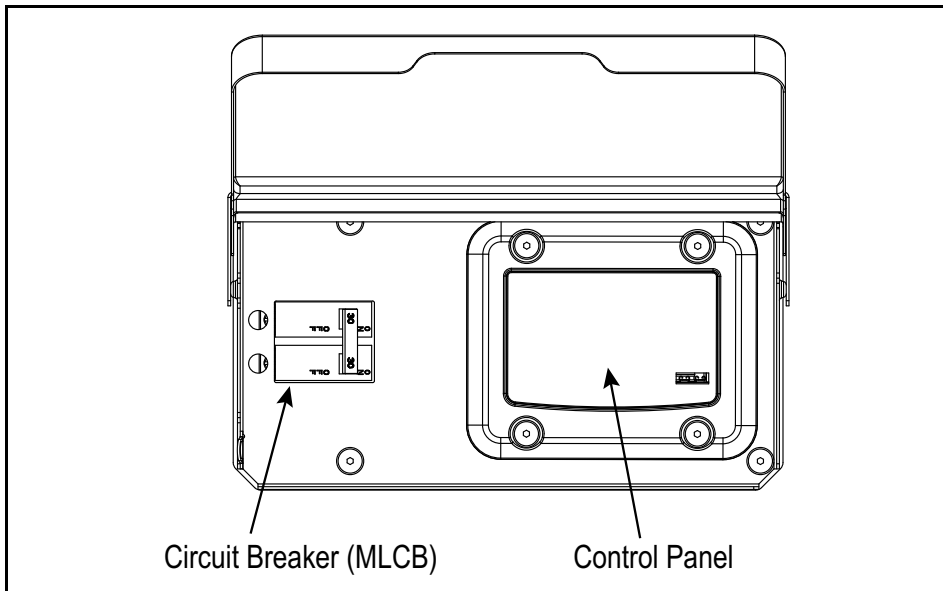

Figure 2-2. Circuit Breaker / Control Panel

3. There are four fasteners securing the top lid. Remove the 4 Allen fasteners and lift the top lid from the generator enclosure.
4. Once the lid is open, remove the front panel by lifting it up and out. Also open the door covering the customer connection area.
5. Perform a visual inspection for any hidden freight damage.

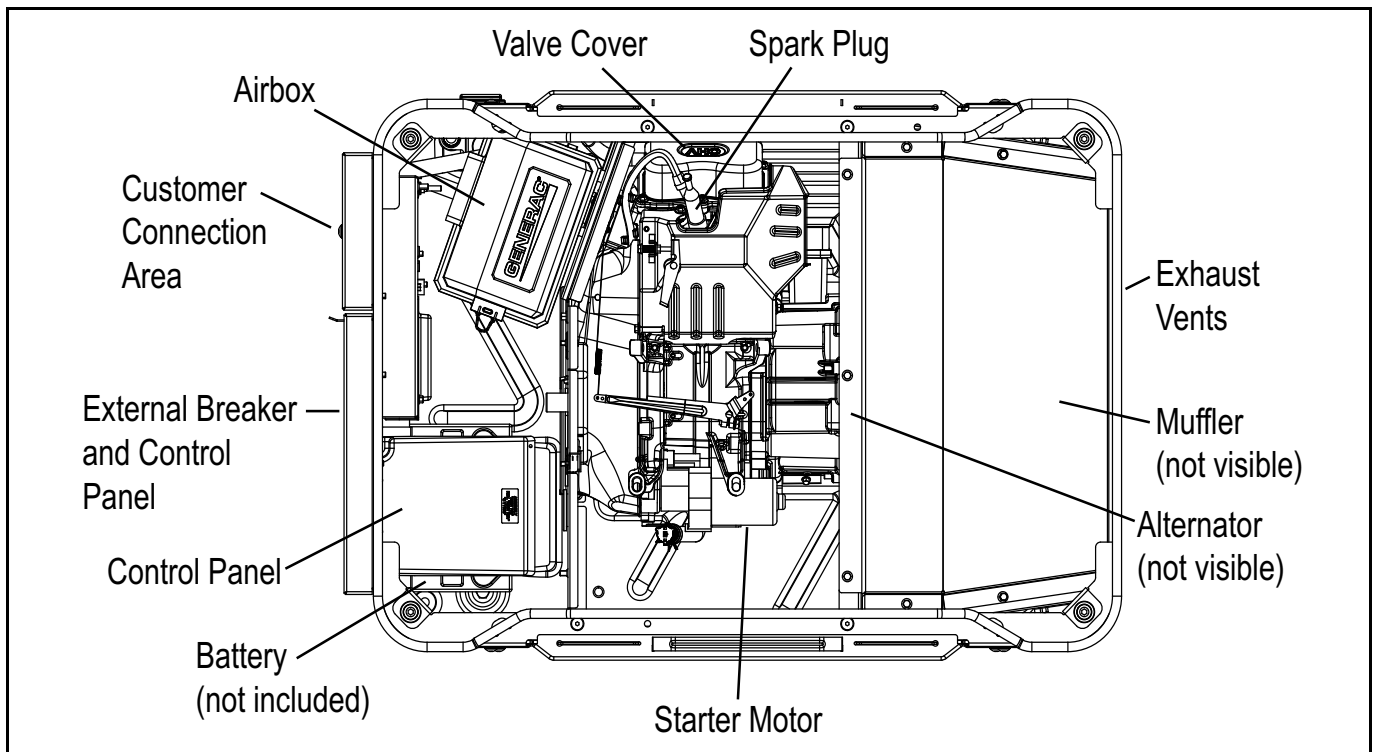

Figure 2-3. Inspect for Damage

2.4 — Parts Shipped Loose

“Loose Shipped Parts” are located inside the unit, in front of the engine or under the alternator.

- Flex Fuel Line
- Battery Terminal Cap
- LP Fuel Jet
- Fuel Jet O-ring
- Decal - Service Entrance (Not Shown)
- Decal - Warning (Not Shown)
- MLCB Terminal Caps
- Owner’s and Installation Manual (Not Shown)
- Battery Bracket
- M6 x 1 16mm Thread Forming Screw (for Battery Bracket)
- 2 sets of Bolts, Nuts and Washers (for connecting battery cables)

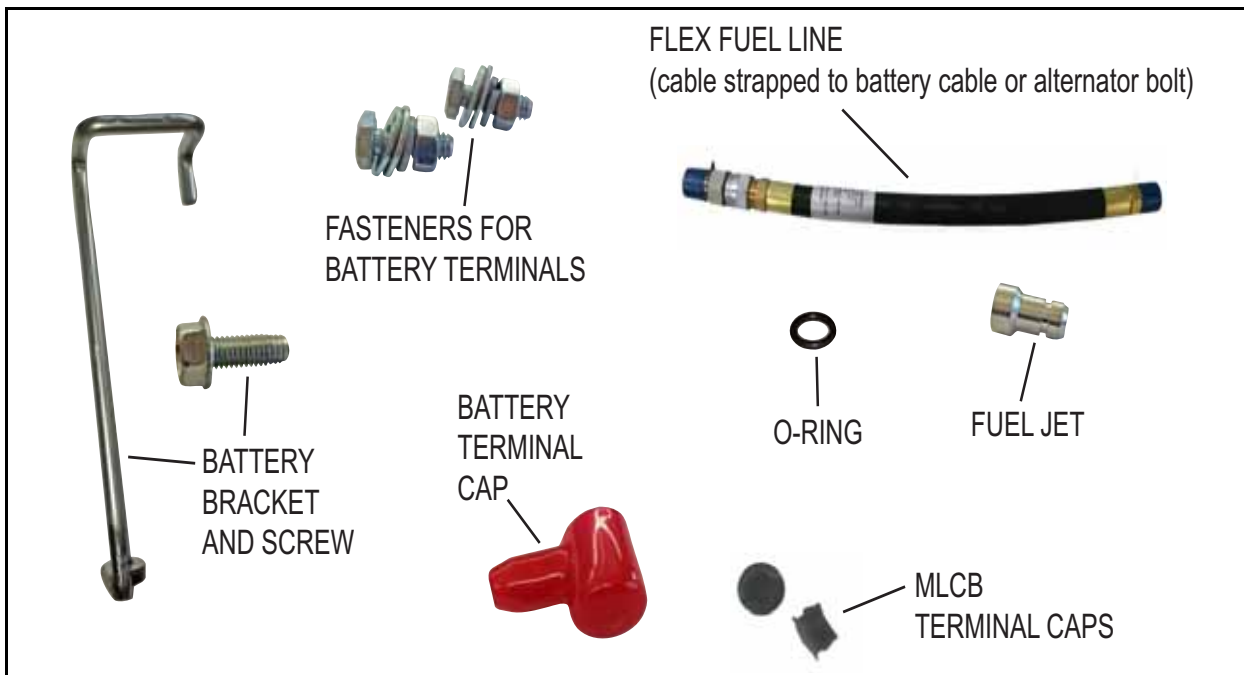

Figure 2-4. Loose Parts

Section 3 Site Selection and Preparation

3.1 — Site Selection

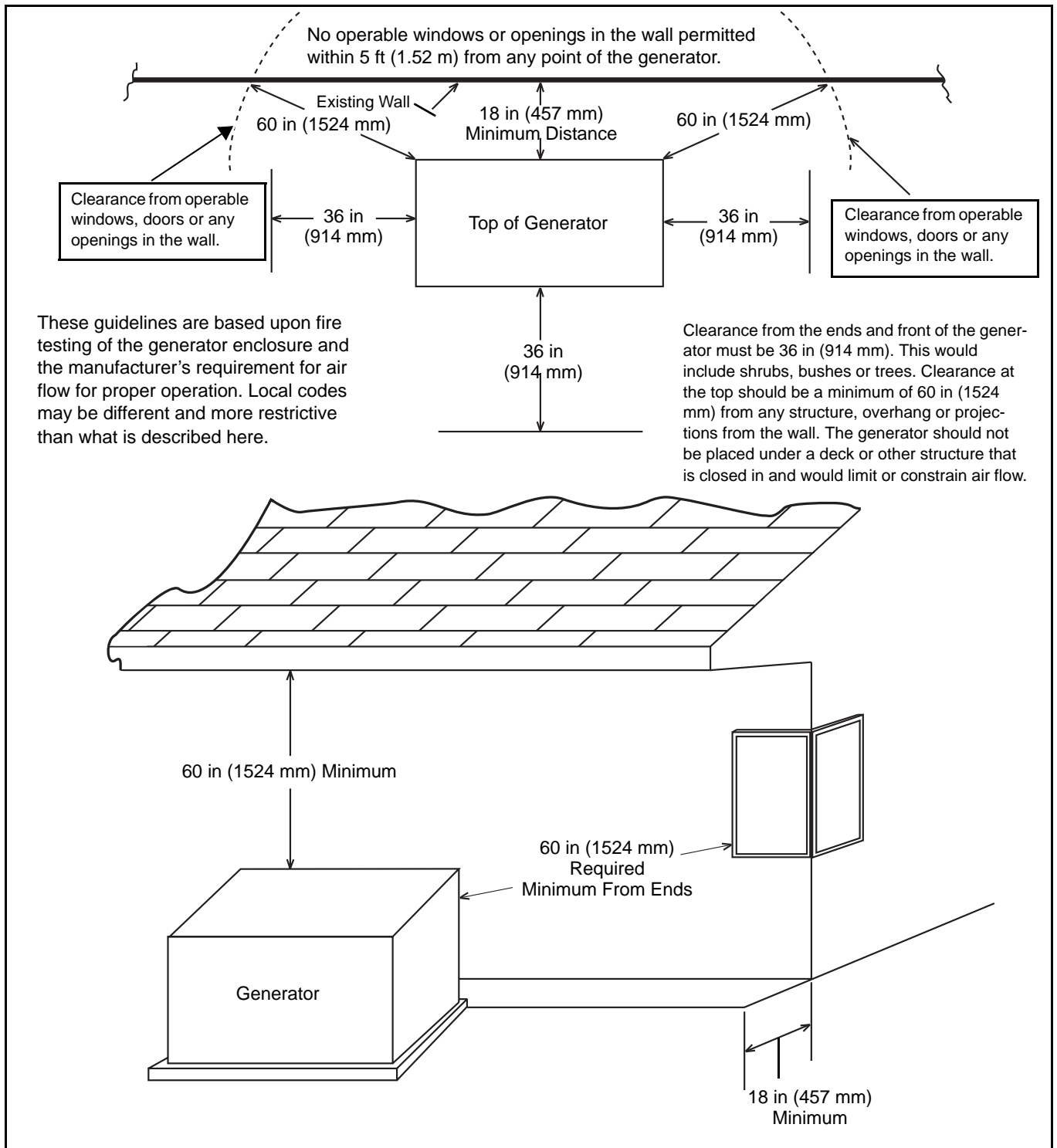

Figure 3-1. Installation Guidelines

Install the generator set, in its protective enclosure, outdoors, where adequate cooling and ventilating air is always available (Figure 1.9). Consider these factors:

- The installation of the generator must comply strictly with NFPA 37, NFPA 54, NFPA 58 and NFPA 70 standards.
- Install the unit where air inlet and outlet openings will not become obstructed by leaves, grass, snow, etc. If prevailing winds will cause blowing or drifting, consider using a windbreak to protect the unit.
- Install the generator on high ground where water levels will not rise and endanger it. It should not operate in or be subjected to standing water.
- Allow sufficient room on all sides of the generator for maintenance and servicing. This unit must be installed in accordance with current applicable NFPA 37 and NFPA 70 standards, as well as any other federal, state and local codes for minimum distances from other structures. DO NOT install under wooden decks or structures unless there is at least 5 ft (1.52 m) of clearance above the generator, 3 ft (.91m) of clearance on sides and front, and a minimum of 18 in (457 mm) of clearance at the back of the unit.
- Install the unit where rain gutter down spouts, roof run-off, landscape irrigation, water sprinklers or sump pump discharge does not flood the unit or spray the enclosure, including any air inlet or outlet openings.
- Install the unit where services will not be affected or obstructed, including concealed, underground or covered services such as electrical, fuel, phone, air conditioning or irrigation. This could affect Warranty Coverage.
- Where strong prevailing winds blow from one direction, face the generator air inlet openings to the prevailing winds.
- Install the generator as close as possible to the fuel supply to reduce the length of piping. REMEMBER THAT LAWS OR CODES MAY REGULATE THE DISTANCE AND LOCATION.
- Install the generator as close as possible to the transfer switch. REMEMBER THAT LAWS OR CODES MAY REGULATE THE DISTANCE AND LOCATION.
- The generator must be installed on a level surface. The generator must be level within a .5 in (13 mm) all around.
- The generator is typically placed on pea gravel, crushed stone or a concrete pad. Check local codes to see what type is required. If a concrete pad is required, all federal, state and local codes should be followed.

3.1.1— Installation Guidelines

The National Fire Protection Association has a standard for the installation and use of stationary combustion engines. That standard is NFPA 37, its requirements limit the spacing of an enclosed generator set from a structure or wall (Figure 1.10).

NFPA 37, Section 4.1.4, Engines Located Outdoors: Engines, and their weatherproof housings if provided, that are installed outdoors shall be located at least 5 ft (1.52 m) from openings in walls and at least 5 ft (1.52 m) from structures having combustible walls. A minimum separation shall not be required where either of the following conditions exist:

1. The adjacent wall of the structure has a fire resistance rating of at least 1 hour.
2. The weatherproof enclosure is constructed of noncombustible materials and it has been demonstrated that a fire within the enclosure will not ignite combustible materials outside the enclosure.

Annex A — Explanatory Material

A4.1.4 (2) Means of demonstrating compliance are by means of full scale fire test or by calculation procedures.

Because of the limited spaces that are frequently available for installation, it has become apparent that exception (2) would be beneficial for many residential and commercial installations. With that in mind, the manufacturer contracted with an independent testing laboratory to run full scale fire tests to assure that the enclosure will not ignite combustible materials outside the enclosure.

NOTE: Southwest Research Institute testing approves 18 in (457 mm) installation minimum from structure. Southwest Research is a nationally recognized third party testing and listing agency.

The criteria was to determine the worst case fire scenario within the generator and to determine the ignitability of items outside the engine enclosure at various distances. The enclosure is constructed of non-combustible materials, and the results and conclusions from the independent testing lab indicated that any fire within the generator enclosure would not pose any ignition risk to nearby combustibles or structures, with or without fire service personnel response.

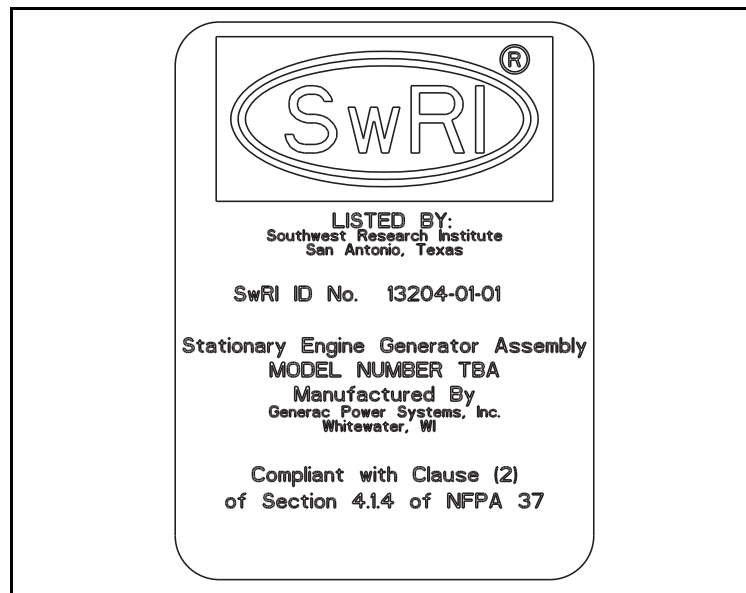

Figure 3-2. Southwest Research Institute Decal

Southwest Research Institute Decal (located inside the generator, next to the generator's data decal)

<http://www.swri.org/4org/d01/fire/listlab/listprod/director.htm>

Based on this testing and the requirements of NFPA 37, Sec 4.1.4, the guidelines for installation of the generators listed above are changed to 18 in (457 mm) from the back side of the generator to a stationary wall or building. For adequate maintenance and airflow clearance, the area above the generator should be at least 5 ft (1.52 m) with a minimum of 3 ft (.91 m) at the front and ends of the enclosure. This would include trees, shrubs and bushes. Vegetation not in compliance with these clearance parameters could obstruct air flow. In addition, exhaust fumes from the generator could inhibit plant growth. See Figure 3.1 and the installation drawing within the owner's manual for details.

Generator exhaust contains DEADLY carbon monoxide gas. This dangerous gas can cause unconsciousness or death. Do not place the unit near windows, doors, fresh air intakes (furnaces, etc.) or any openings in the building or structure, including windows and doors of an attached garage.

⚠ WARNING!



If the generator is not set to the OFF mode, it can crank and start as soon as the battery cables are connected. If the utility power supply is not turned off, sparking can occur at the battery posts and cause an explosion.

3.2 — Site Preparation

- Locate the mounting area as close as possible to the transfer switch and fuel supply.
- Leave adequate room around the area for service access (check local code), and place high enough to keep rising water from reaching the generator.
- Choose an open space that will provide adequate and unobstructed airflow.
- Place the unit so air vents won't become clogged with leaves, grass, snow or debris. Make sure exhaust fumes will not enter the building through eaves, windows, ventilation fans or other air intakes (see the "Site Selection" section).
- Select the type of base, such as but not limited to gravel or concrete, as desired or as required by local laws or codes. Verify your local requirements before selecting.

3.2.1— Material Sufficient for Level Installation

- Dig a rectangular area approximately 5 in (127 mm) deep and about 6 in (152 mm) longer and wider than the footprint of the generator. Fill with 4 in (102 mm) of pea gravel, crushed stone or any other non-combustible material sufficient for level installation, or on a concrete pad. Compact and level the material. A concrete pad can be poured if desired or required. The pad should be 4-5 in (102-127 mm) thick and extend 6 in (152 mm) beyond the outside of the generator in all directions.

NOTE: If a concrete pad is required, follow all applicable Federal, State or local codes.



Figure 3-3. Compacted Gravel Site



Figure 3-4. Concrete Pad Site

3.2.2— Transportation Recommendations

- Use a two wheeled hand cart or metal rails to carry the generator (including the wooden pallet) to the installation site. Place cardboard between the hand cart and the generator to prevent any damage or scratches to the generator.
- Remove bolts and pallet brackets. Exercise caution when removing the generator. Dragging it off the pallet **WILL** damage the base. The generator must be lifted from the wooden pallet to remove the clamps.

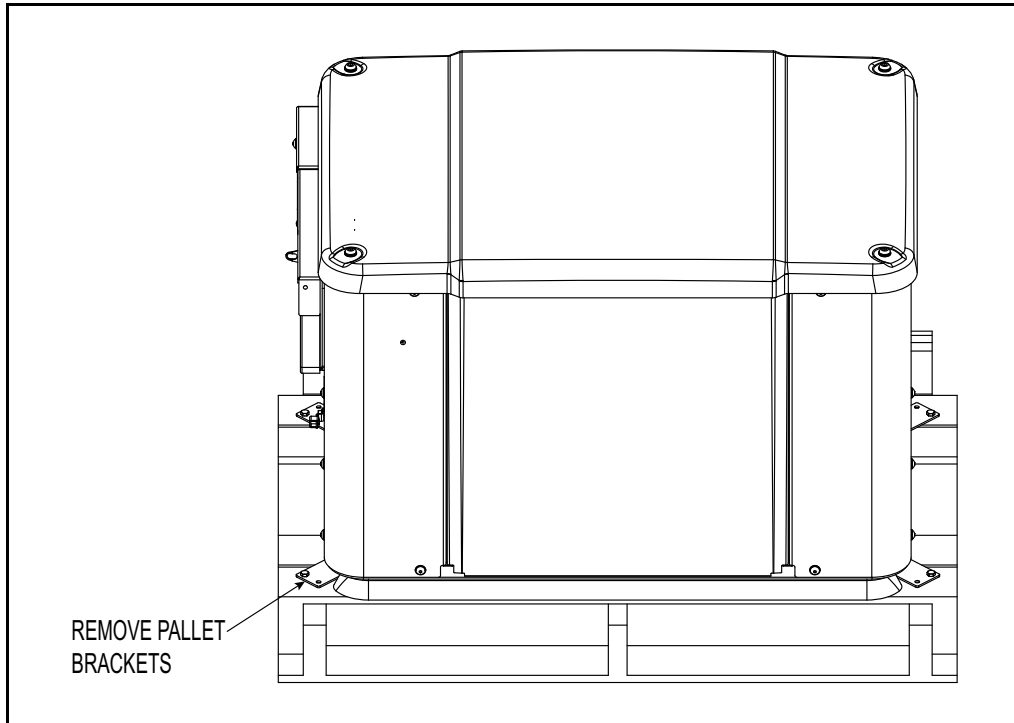

Figure 3-5. Generator on Pallet

This Page Intentionally Left Blank

Section 4 Generator Placement

4.1 — Generator

Lift the generator from the wooden pallet and place it on 4 in (102 mm) of pea gravel, crushed stone or any other non-combustible material sufficient for level installation, or on a concrete pad. Check local codes to see what type of site base is required. If a concrete pad is required, all federal, state and local codes should be followed. Place the generator on its mounting pads and position correctly as per the dimensional information given in Section 2.

NOTE: Generator must be level within 0.5 in (13 mm).

When mounting the generator to concrete, there are four mounting holes inside the generator enclosure for securing the generator. See Figure 4.1. The use of 5/16" (or M8) lag bolts is recommended (not supplied) for securing the generator to a concrete pad.

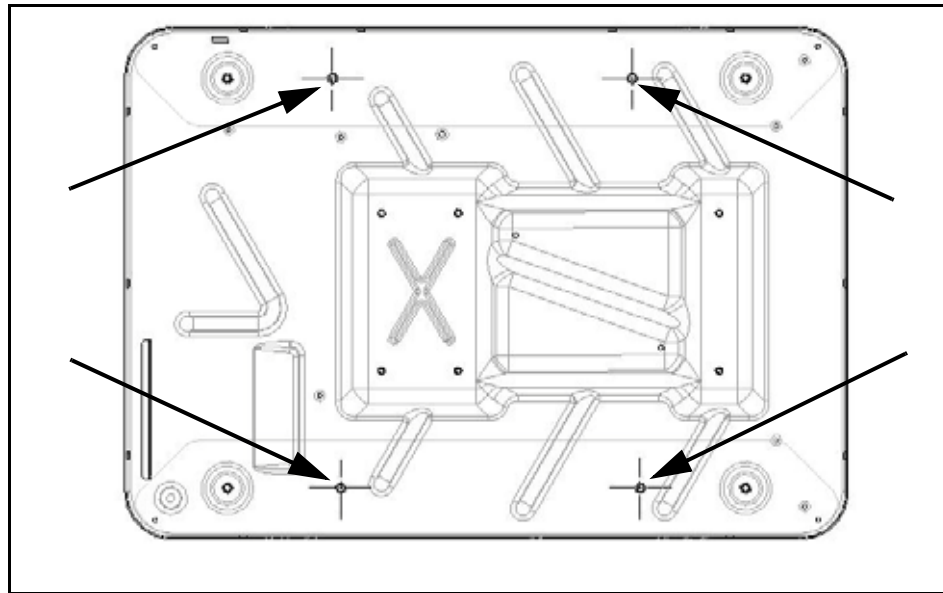

Figure 4-1. Mounting Hole Location

NOTE: The top of the generator carton has a template that can be used to mark the concrete pad to pre-drill the mounting holes.

This Page Intentionally Left Blank

Section 5 Fuel Conversion/Gas Connections

5.1 — Fuel Conversion

The generator was configured for natural gas (NG) operation at the factory. The following procedure will enable the generator to operate on LP vapor fuel.

1. Remove the four 6mm Allen head fasteners and lift the top lid from the generator enclosure.
2. Remove the two 4mm Allen head fasteners. Lift and remove the rear panel.
3. Use a pliers to squeeze the hose clamp and slide from the fuel inlet fitting.
4. Remove the hose from the fuel inlet.
5. Remove the Natural Gas (NG) fuel jet from the fuel inlet. If the nozzle is found to be inside the hose, remove it with a needle nose pliers.
6. Locate the fuel jet for propane use (supplied). It has a smaller inside diameter than the NG jet.
7. Insert the propane fuel jet into the end of the fuel inlet.
8. Reinstall the hose onto the fuel inlet. Secure the hose with the clamp.
9. Verify the hose has not been kinked in any way.
10. Reinstall the rear access panel by hooking it on the top of the unit. Check to be sure the alternator bellow is completely secure around the frame provided on the access panel. Attach the panel firmly to the unit with the 2 shorter Allen screws.
11. Reinstall the top lid firmly with the 4 long Allen screws.

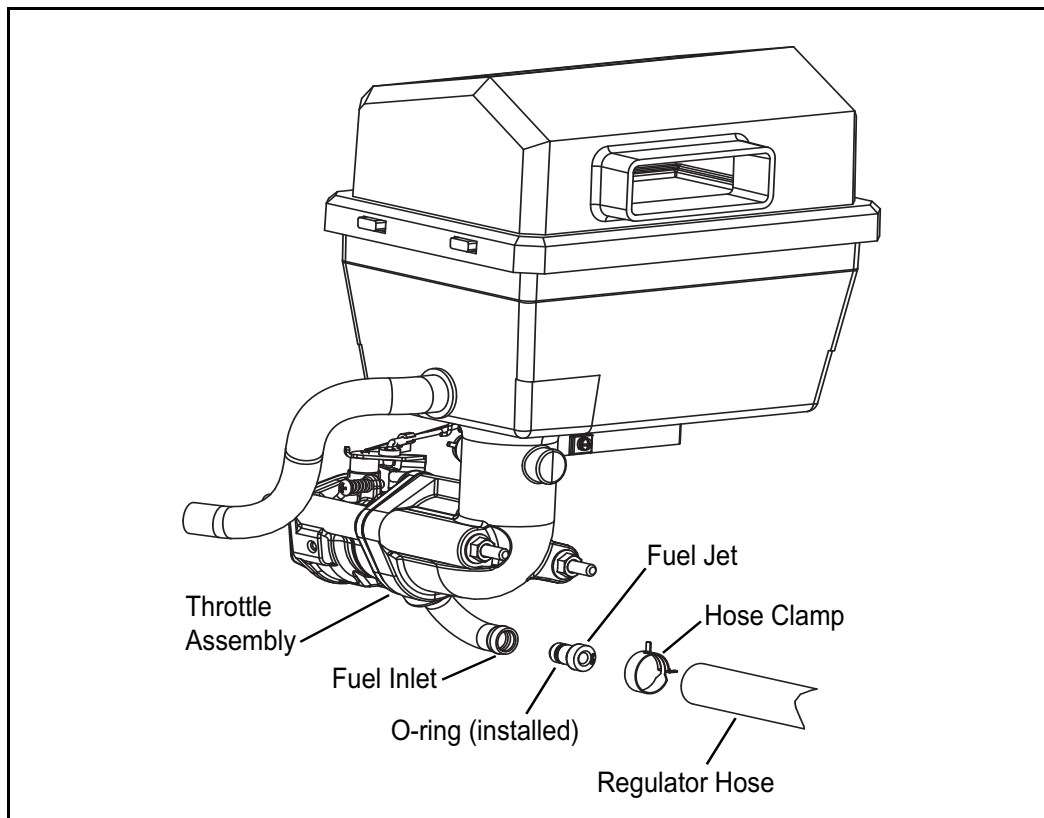

Figure 5-1. Fuel Conversion

5.2 — Fuel Requirements and Recommendations

With LP gas, use only the vapor withdrawal system. This type of system uses the vapors formed above the liquid fuel in the storage tank.

The engine has been fitted with a fuel system that meets the specifications of the 1997 California Air Resources Board for tamper-proof dual fuel systems. The unit will run on natural gas or LP gas, but it has been factory set to run on natural gas. Should the primary fuel need to be changed to LP gas, the fuel system needs to be reconfigured. See the Fuel Conversion section for instructions on converting the fuel system.

Recommended fuels should have a Btu content of at least 1,000 Btus per cubic foot (37.26 megajoules per cubic meter) for natural gas; or at least 2,500 Btus per cubic foot (93.15 megajoules per cubic meter) for LP gas. Ask the fuel supplier for the Btu content of the fuel.

Required fuel pressure for natural gas is 5-7" water column (9-13 mm mercury). Required fuel pressure for liquid propane vapor is 10-12" water column (19-22 mm mercury). The primary regulator for the propane supply is NOT INCLUDED with the generator.

NOTE: All pipe sizing, construction and layout must comply with NFPA 54 for natural gas applications and NFPA 58 for liquid propane applications. Once the generator is installed, verify that the fuel pressure NEVER drops below it's required fuel pressure rating. For further information regarding NFPA requirements refer to their website at www.nfpa.org.

Prior to installation of the generator, the installer should consult local fuel suppliers or the fire marshal to check codes and regulations for proper installation. Local codes will mandate correct routing of gaseous fuel line piping around gardens, shrubs and other landscaping to prevent any damage.

Special considerations should be given when installing the unit where local conditions include flooding, tornadoes, hurricanes, earthquakes and unstable ground for the flexibility and strength of piping and their connections.

Use an approved pipe sealant or joint compound on all threaded fittings.

All installed gaseous fuel piping must be purged and leak tested prior to initial start-up in accordance with local codes, standards and regulations.

5.3 — Fuel Consumption

NOTE: Required fuel pressure for natural gas is 5-7 in. water column (9-13 mm mercury). The required fuel pressure for LP Vapor is 10-12 in water column (19-22 mm mercury).

These are approximate values, use the appropriate spec sheet or owner's manual for specific values.

Unit	Natural Gas		LP Vapor	
	1/2 Load	Full Load	1/2 Load	Full Load
6 / 7 kW	73 / 2.07	117 / 3.31	26.1 / 0.73 / 2.75	46.8 / 1.3 / 4.9
* NG given in cubic feet / cubic meter. LP given in cubic feet / gallons per hour / liter per hour. ** Values given are approximate.				

Verify that gas meter is capable of providing enough fuel flow to include household appliances and all other loads.

⚠ DANGER!



Gaseous fuels such as natural gas and liquid propane (LP) gas are highly explosive. Even the slightest spark can ignite such fuels and cause an explosion. No leakage of fuel is permitted. Natural gas, which is lighter than air, tends to collect in high areas. LP gas is heavier than air and tends to settle in low areas.

NOTE: A minimum of one approved full flow manual shut-off valve must be installed in the gaseous fuel supply line. The valve must be easily accessible. Local codes determine the proper location.

NOTE: The gas supply and pipe MUST be sized at 125% Load BTU / megajoule rating.

5.4 — Fuel Line Sizing

- First, determine what size pipe is required. Refer to NFPA 54 for NG or NFPA 58 for LP for further information.
- Always refer to the owner’s manual for the proper BTU / megajoule and required gas pressures. To calculate BTU or Megajoules:
 - Natural Gas: $BTU = \text{Cubic feet} / \text{hour} \times 1000$
 $\text{Megajoules} = \text{Cubic meters} / \text{hour} \times 37.26$
 - Liquid Propane Vapor: $BTU = \text{Cubic feet} / \text{hour} \times 2500$
 $\text{Megajoules} = \text{Cubic meters} / \text{hour} \times 93.15$
- Start by measuring the distance from the generator to the gas source. The generator should be plumbed directly from the source, not off the end of an existing system.
- When measuring the pipe length, add 2.5 ft (.76 m) for every angle or bend in the pipe and add that to the overall pipe distance.

5.4.1— Natural Gas Pipe Sizing

To properly use this chart, find the kW rating of the generator in the left column, and trace to the right. The number to the right is the maximum length (measured in feet / meters) allowed for the pipe sizes on top. The pipe sizes are measured by inside diameter (ID) to include any fittings, valves (must be full flow), elbows, tees or angles. Add 2.5 ft (.76 m) per any bend, tee or angle in the pipe to the overall distance.

Pipe Size					
kW	.75 in. / 19 mm	1 in. / 25 mm	1.25 in. / 32 mm	1.5 in. / 38 mm	2 in. / 51 mm
6	50 ft. / 15 m	150 ft. / 46 m	600 ft. / 183 m	-	-
For 5-7" of water column (9-13mm mercury).					

5.4.2— LP Vapor Pipe Sizing

To properly use this chart, find the kW rating of the generator in the left column, and trace to the right. The number to the right is the maximum length (measured in feet / meters) allowed for the pipe sizes on top. The pipe sizes are measured by inside diameter (ID) to include any fittings, valves (must be full flow), elbows, tees or angles. Add 2.5 ft (.76 m) per any bend, tee or angle in the pipe to the overall distance.

NOTE: Pipe sizes are using a second stage regulator.

NOTE: Determine the LP tank size based on the generator and connected loads required.

Pipe Size			
kW	.75 in. / 19mm	1 in. / 25mm	1.25 in. / 32mm
7	165 ft. / 50 m	450 ft. / 137 m	-

5.4.3— Gas Installation Summary

Gas pipe sizing is one of the most commonly made mistakes. A properly sized gas pipe is critical to the proper operation of the generator. **The generator inlet size has no bearing on the proper gas pipe size.**

NOTE: The gas supply and pipe MUST be sized at 125% Load BTU / megajoule rating.

5.5 — Installing and Connecting Gas Lines

- Both natural gas and LP Vapor are highly volatile substances, so strict adherence to all safety procedures, codes, standards and regulations is essential.

Gas line connections should be made by a certified plumber familiar with local codes. Always use AGA-approved gas pipe and a quality pipe sealant or joint compound.

Verify the capacity of the natural gas meter or the LP tank in regards to providing sufficient fuel for both the generator and other operating appliances.

- Fuel Regulator installed per laws or regulator manufacturer's specifications
 - AGA approved gas pipe
 - Flexible fuel line
 - Do not install vertically
 - Do not bend
 - Do not attach directly to generator
 - Check all connections for leaks
 - A bell reducer may be required to install the flexible fuel line to comply with the code.
 - Sediment trap near generator
 - Full flow rated shut-off near generator per local jurisdiction or code
- Most applications will require an external manual full flow shutoff valve on the fuel line.

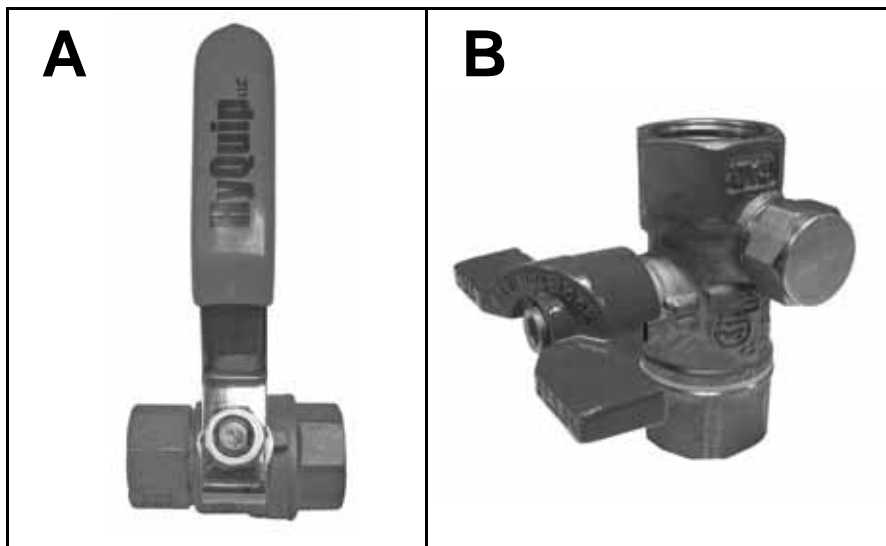

Figure 5-2. Accessory Valve with Manometer Port

NOTE: Figure 5-2 illustrates a fuel shut-off valve with a manometer port for making fuel pressure checks. This accessory valve permits making pressure checks without going into the generator enclosure.

Valves available through Generac and independent authorized dealers:

- 1/2" ball valve, part number 0K8752
- 3/4" ball valve, part number 0K8754

- When connecting the gas line to the generator, use the provided section of UL Listed or AGA-approved flexible fuel line installed horizontally in accordance with local regulations. The purpose of the flexible fuel line is to ensure that vibration from the generator does not cause a gas leak at one of the connection points, so it's important that the line be installed with as few bends as possible. Configure the sediment trap (if applicable or required by code) (Figure 5-3.).



Figure 5-3. Sediment Trap (typical)



Figure 5-4. Incorrect Routing of Flexible Hose

- Never bend the flexible fuel line to avoid using an elbow. Bending the flexible line decreases its ability to absorb vibrations and defeats its purpose, as well as constricts the actual fuel flow (Figure 5-4.).

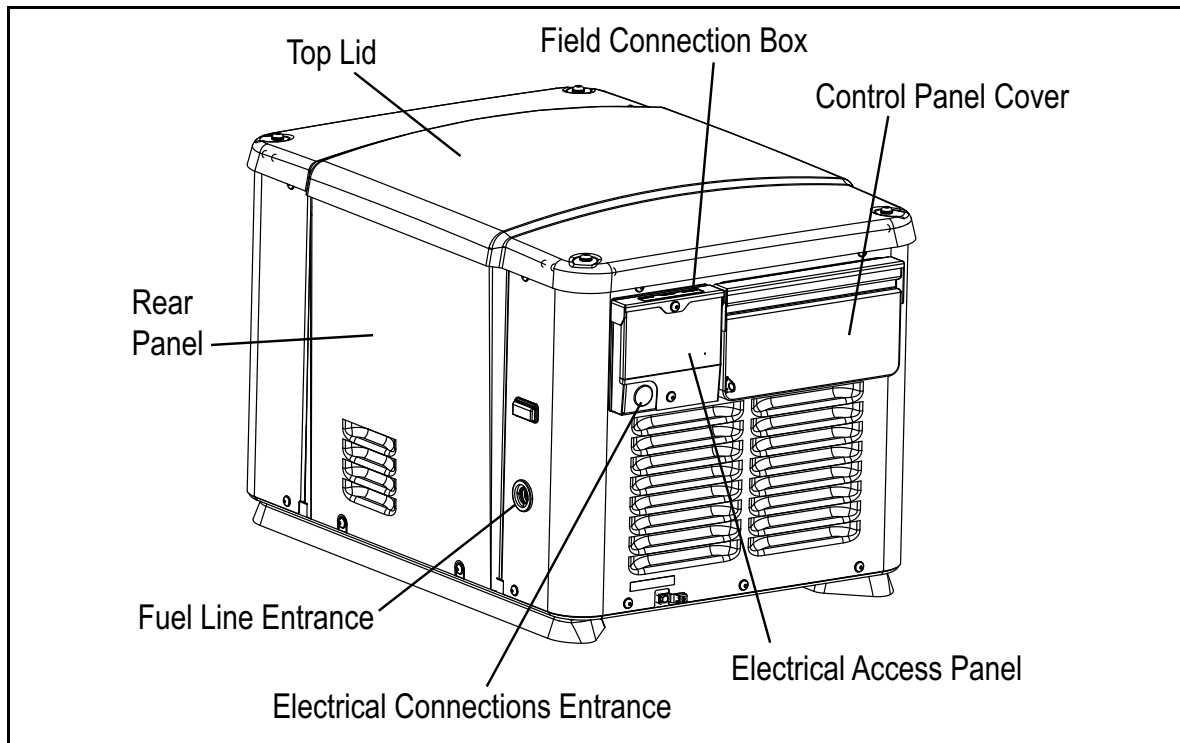

Figure 5-5. Fuel Line and Electrical Locations

5. Remove the top lid and rear panel.
6. Check for leaks by spraying all connection points with a soap solution made of dish washing soap and water. You should not see the solution be “blown away” or form “bubbles”. Next, check the gas pressure at the regulator in the generator by following these steps.
 - Close gas supply valve.
 - Remove the top gas pressure test port from the regulator (see Figure 5-6.) and install the gas pressure tester (manometer).
 - Slowly open the gas supply valve and ensure that the pressure is within the specified values.

NOTE: See owner’s manual or spec sheet for proper fuel pressure specifications. If the gas pressure is not within specifications, contact the local gas supplier.

7. Close gas valve when completed.
8. Reinstall the rear access panel by hooking it on the top of the unit. Check to be sure the alternator bellow is completely secure around the frame provided on the access panel. Attach the panel firmly to the unit with the 2 shorter Allen screws.
9. Reinstall the top lid firmly with the 4 long Allen screws.

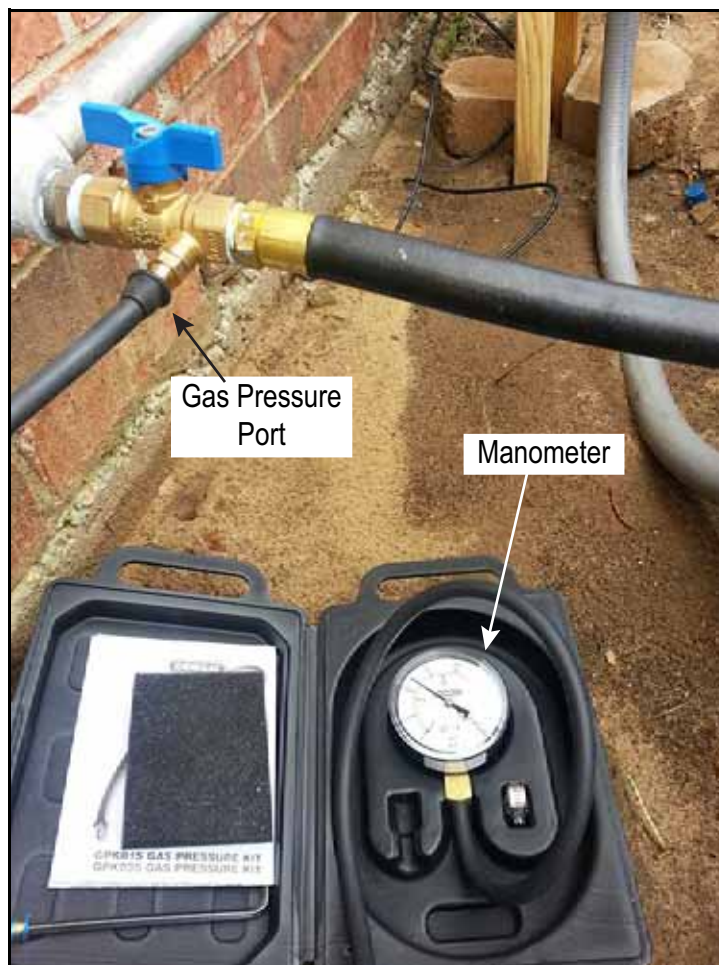

Figure 5-6. Checking Pressure with Manometer

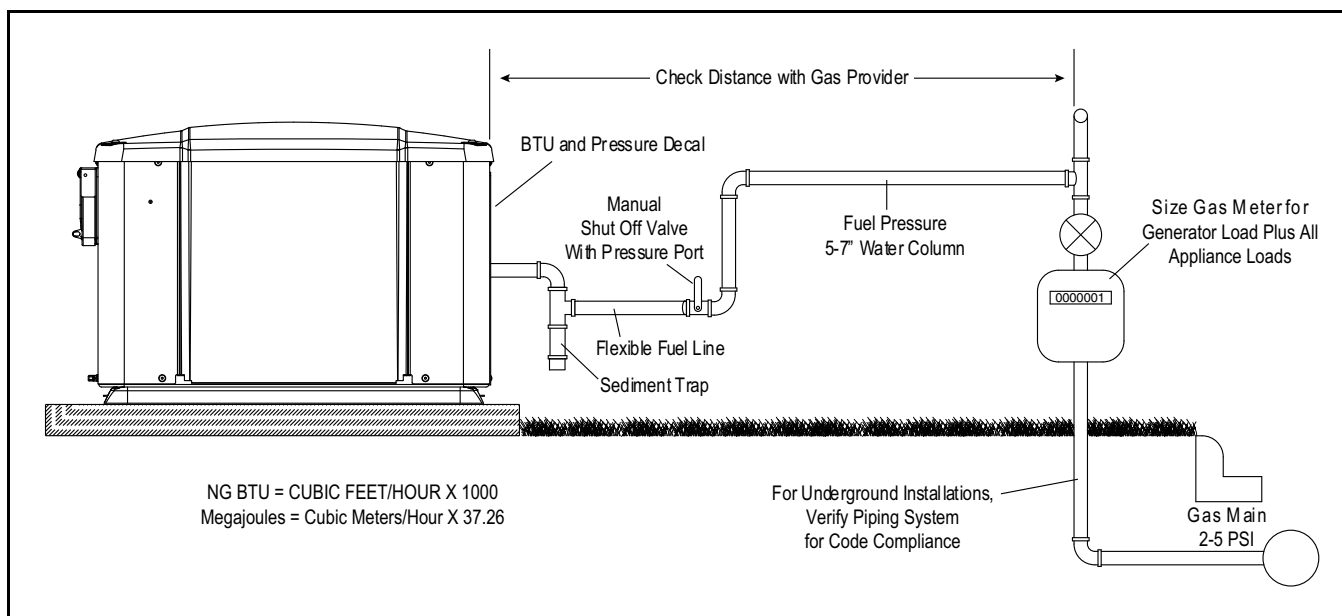

Figure 5-7. Typical Natural Gas Vapor Installation

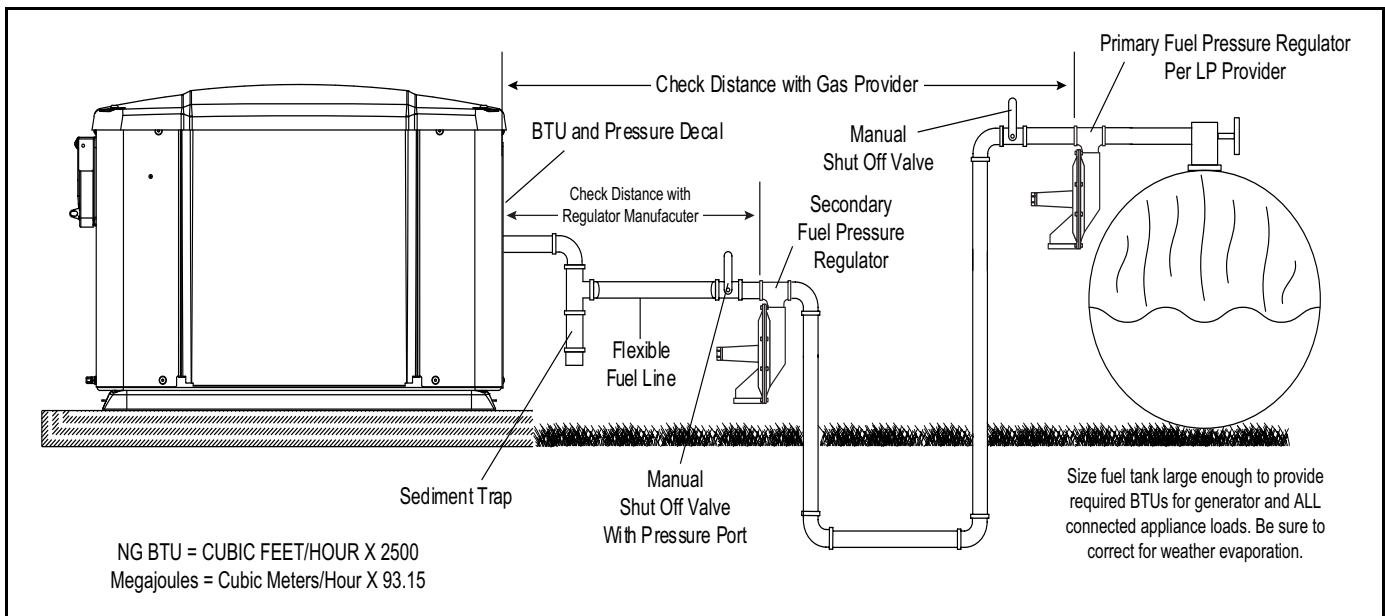

Figure 5-8. Typical LP Vapor Installation

NOTE: When sizing a secondary regulator for LP or high pressure natural gas applications be sure to note the maximum individual load capabilities which will be lower than total capacity. This could impact generator starting performance if sized too small.

NOTE: It is not recommended to reduce the fuel pipe size exiting the secondary regulator unless necessary to accommodate the 1/2" or 3/4" flexible fuel line that is shipped with the generator. This may potentially cause starting or performance issues.

Section 6 *Electrical Connections*

6.1 — Control Wiring

Control Wire Recommended Length and Size	
Maximum Wire Length	Recommended Wire Size
1-115 ft (1-35 m)	No. 18 AWG
116-185 ft (36-56 m)	No. 16 AWG
186-295 ft (57-89 m)	No. 14 AWG
296-460 ft (90-140 m)	No. 12 AWG

Control Panel Connections		
Terminal Numbering Decal		Wire Numbers
A	YELLOW #1 & #2	N1 & N2 - 240 VAC - Sensing for Utility Dropout and Pickup
B	BLUE #3	T1 - Fused 120VAC for Battery Charger (see NOTE)
C*	BLACK #3	0 - DC (-) Common Ground Wire
D	RED #4	194 - DC (+) 12 VDC for Transfer Controls
E	WHITE #5	23 - Transfer Control Signal Wire

NOTE: T1 must be connected to keep battery charged whether unit is running or not.
*** Required if generator is paired with a Generac Smart Power management transfer switch.**

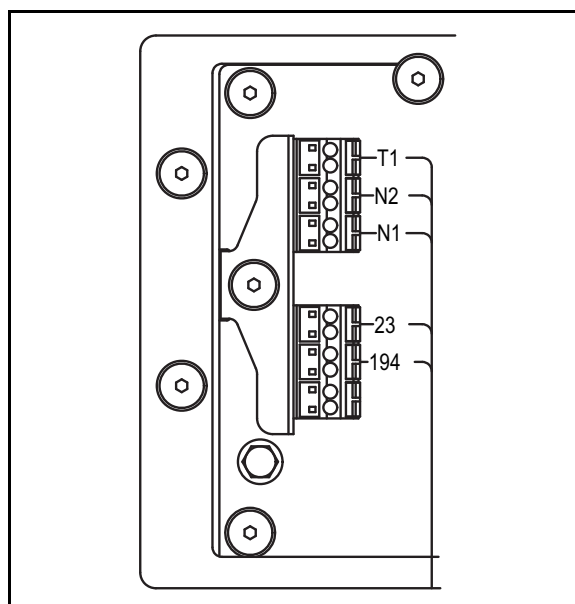

Figure 6-1. Control Wiring

NOTE: Control wiring must be in accordance with local jurisdiction and codes.

1. Remove the plug from the field connection box.
2. Remove the two Allen screws to remove the electrical access panel. The access panel will hang off of the grounding wire.

▲ CAUTION!



Do not pull the panel causing the ground wire to detach from the grounding bus bar.

3. Install the conduit and Main AC and Control Wires between the generator and the transfer switch (Figure 6-2). Through a NEMA 3 rated external connection box (not supplied).

NOTE: The Electrical access panel is grounded to the ground bar through a grounding wire. Ensure the integrity of this connection before closing the panel back.

NOTE: This wiring can be run in the same conduit if the appropriate insulation rated wire is used.

4. Seal the conduit at the generator and in compliance with any codes.
5. Strip the insulation from the ends of the wires. Do not remove excessive insulation.
6. To connect the control wires, push down on the spring loaded connection point with a flat head screwdriver, insert wire and release.

NOTE: No wire insulation should be in the connection point, only bare wire.

6.2 — Main AC Wiring

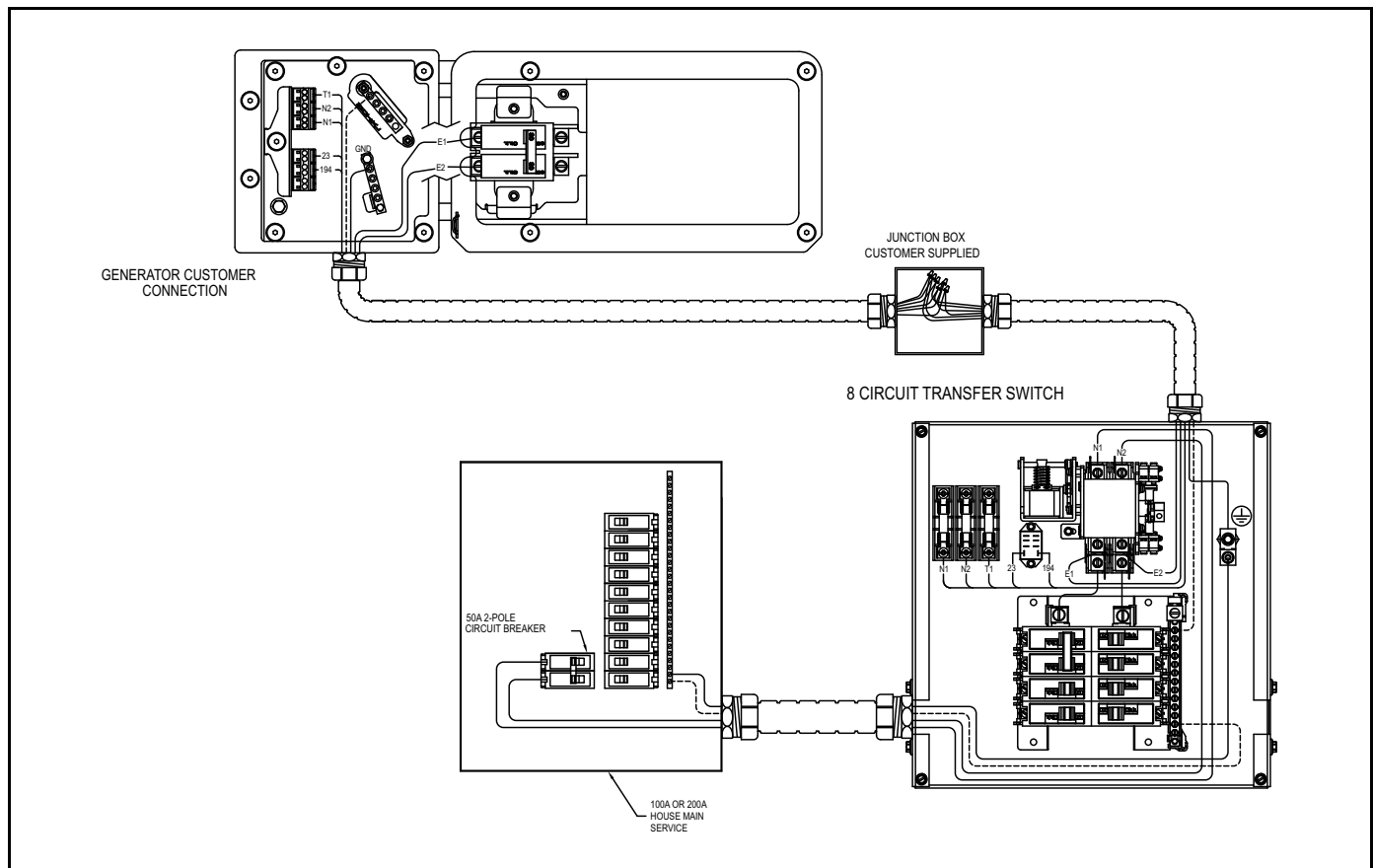

Figure 6-2. Main AC Wiring

NOTE: Main AC wiring must be in accordance with local jurisdiction and codes.

1. Strip the insulation off the wire ends. Do not remove excessive insulation.
2. Open the controller access panel and latch it. Loosen the lugs of the Main Breaker through the access holes.
3. Insert a power wire (E1 or E2) into the bottom lug of the Main Breaker. Torque to the proper specification.
4. Connect the Neutral wire to the Neutral Lug and torque to the required specification. See Figure 6.2.
5. Connect the Ground wire to the Ground Lug and torque to the required specification. See Figure 6.2.
6. Plug the breaker access hole with the cap plugs provided (see Loose Parts).
7. Unlatch the controller access panel by pulling towards you and then close the lid.
8. Confirm the integrity of the ground wire connection between the electrical access panel and the ground lug while closing the customer connection box using the two short allen screws.

NOTE: Neutral Bonding - For installations that require the neutral to be bonded to the ground, this is to be done on the customer connections terminals inside the generator. Connect a suitably sized wire from the neutral bar to the ground bar. This is normally required when the generator is the source in a separately derived system. It is not required when the generator is a backup source in a utility supplied electrical system with a 2-pole transfer switch. See Figure 6-1.

NOTE: Torque all wiring lugs, bus bars and connection points to the proper torque specifications. Torque specifications for the Main Line Circuit Breaker (MLCB) can be found on a decal located on the inside of the electrical access panel.

6.3 — Battery Requirements

Group U1, 12V, minimum 300 CCA (Generac Part No. OD4575).

6.4 — Battery Installation

Fill the battery with the proper electrolyte fluid if necessary and have the battery fully charged before installing it.

Before installing and connecting the battery, complete the following steps:

1. Verify that the generator has been turned OFF.
2. Turn off utility power supply to the transfer switch.
3. Remove the 7.5 Amp ATO[®] fuse from the generator control panel.
4. Remove the top lid of the generator by loosening the 4 Allen screws.
5. Remove the front access panel with the handle by unhooking it from the generator.
6. Remove the battery access panel by removing the 2 hex head screws.
7. Pull both the black and red battery cables through the battery access panel.

Battery cables were factory connected at the generator. Connect cables to battery posts as follows:

8. Place the recommended battery next to the engine of the generator with the positive post towards the front, and the negative towards the back.
9. Connect the red battery cable (from starter contactor) to the battery post indicated by a positive, POS or (+) and secure it using the bolt, washers and nut provided with the loose parts (Figure 6-3.).
10. Connect the black battery cable (from engine ground) to the battery post indicated by a negative, NEG or (-) and secure it using the bolt, washers and nut provided with the loose parts (Figure 6-3.).
11. Apply dielectric grease to battery posts and terminals after connection.
12. Install the red battery post cover (included).
13. Slide the battery through the battery access window and ensure it is seating correctly in the base, resting on a bracket in the back side. A hole provided in the angled pad on the base will be visible in this position.
14. Install the battery bracket provided in the loose parts and mount it securely to the base using the M6 thread forming screw provided (Figure 6-4.).

⚠ CAUTION!



Shorting battery terminal can cause equipment damage. Use caution to avoid shorting terminal during connection.

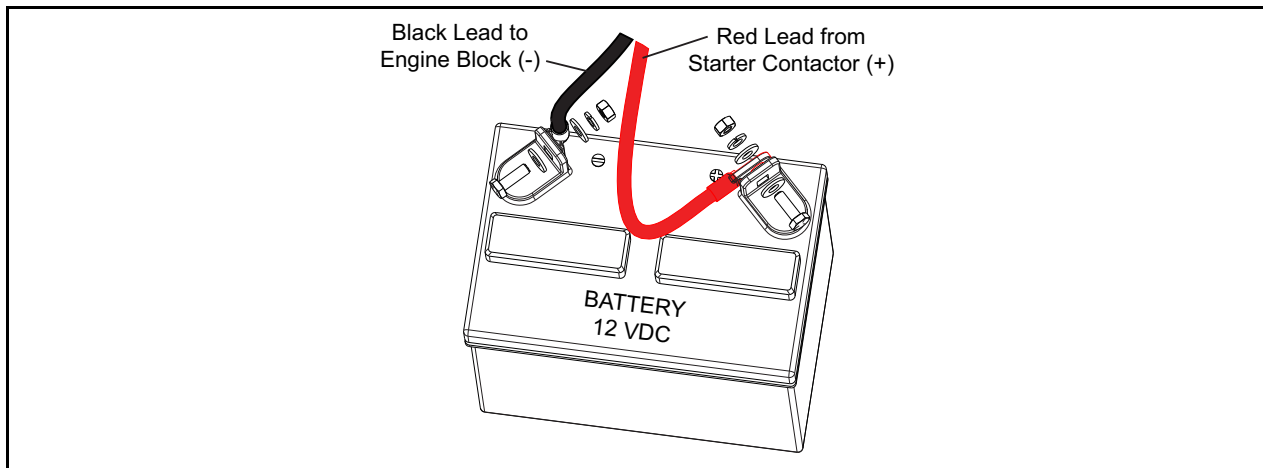

Figure 6-3. Battery Cable Connections

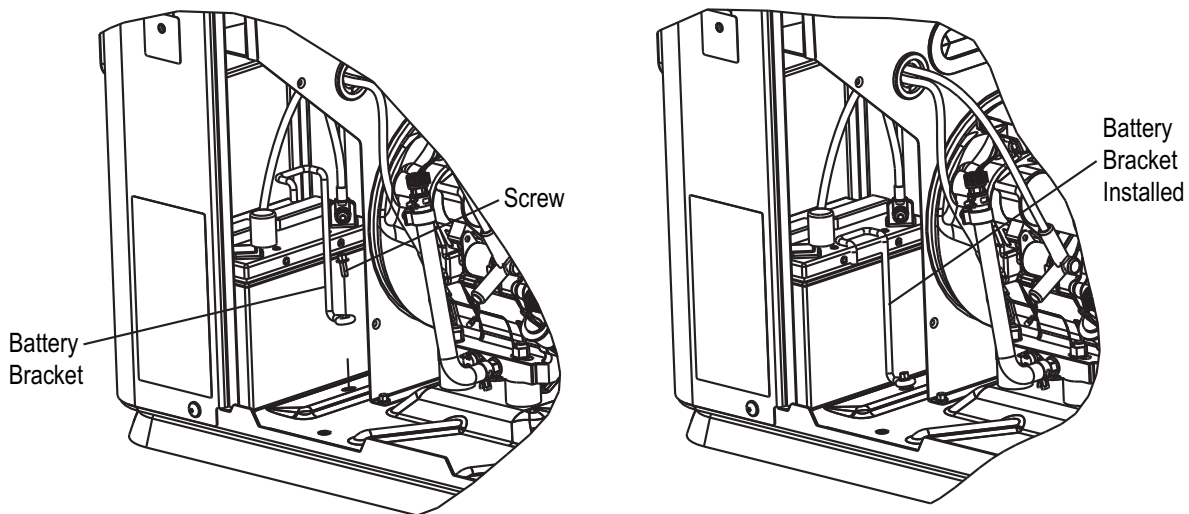

Figure 6-4. Battery Installation

15. Install the 7.5 Amp ATO® fuse in the generator control panel.
16. Assemble the battery access panel with the 2 hex head screws and tighten securely.
17. Assemble the front door by hooking it to the base and aligning the slots to the hooks on the top of the enclosure.
18. Assemble the top lid with the 4 Allen screws and secure it in place.

⚠ CAUTION!



Connecting battery incorrectly can cause equipment damage. Verify battery polarity before making connections.

NOTE: Use a pad-type battery heater in cold climate areas with temperatures typically below 32 °F (0 °C). See an authorized service dealer for the appropriate cold weather kit.

Section 7 Installation Checks and Tests

7.1 — Control Panel Interface

7.1.1— Using Auto/Manual/Off/Set Exercise Buttons

⚠ WARNING!



Engine may start without notice. Press the OFF button, remove fuses and disconnect battery before performing work on or around the generator or transfer switch. Failure to do so can cause death or serious injury.

⚠ CAUTION!



With AUTO mode active, the engine may crank and start at any time without warning. Such automatic starting occurs when utility power source voltage drops below a preset level or during the normal exercise cycle.

Button	Description of Operation
AUTO (GREEN)	Selecting this button activates fully automatic system operation. It also allows the unit to automatically start and exercise the engine every seven days with the setting of the exercise timer (see the “Setting the Exercise Timer” section).
OFF (RED)	This button shuts down the engine and also prevents automatic operation of the unit.
MANUAL (BLUE)	This button will crank and start the generator. Transfer to standby power will not occur unless there is a utility failure.
SET EXERCISE (GREY)	Used to establish generator exercise time. Hold the button for 3 seconds at the new exercise time desired. NOTE: Exercise time can only be set at the time you wish exercise to actually take place. If Exercise is not set, it will default to the last time power was applied (T1 or Battery) to the control panel.

NOTE: Damage caused by mis-wiring of the interconnect wires is not warrant-able.

NOTE: Loss of utility power will cause either the AUTO or OFF or MANUAL buttons to flash. Whichever mode the generator is in at the time of utility loss.

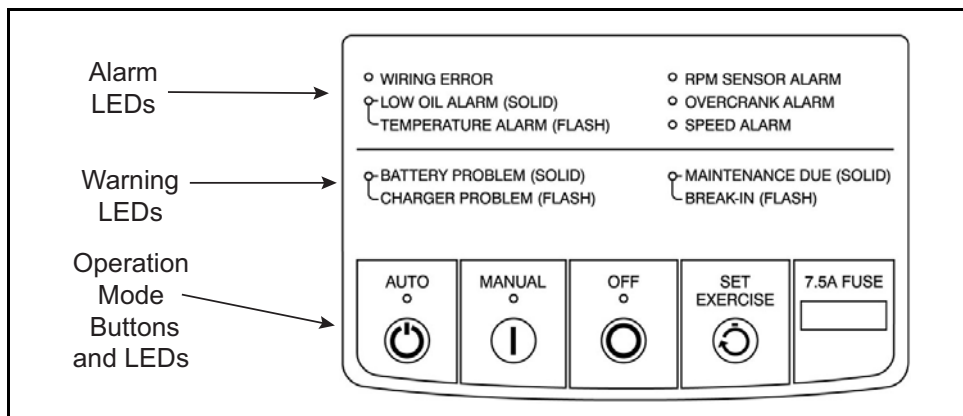

Figure 7-1. Control Panel

7.2 — Before Initial Start-Up

▲ CAUTION!



Never operate the engine with the oil level below the “Add” mark on the dipstick. Doing this could damage the engine.

NOTE: This unit comes filled with 30 weight organic oil from the factory. Check the oil level and add the appropriate viscosity and amount if necessary.

NOTE: Do not use or add synthetic oil until the generator has operated for a minimum of 50 hours.

7.3 — Generator Activation

The generator needs to be activated before it will automatically run in the event of a power outage.

Activating the generator is a simple, one-time process. Once the product is activated, you will not be prompted to activate again, even if you disconnect the generator battery.

NOTE: If the AUTO button is pressed prior to activation of the generator, the AUTO, OFF and MANUAL LEDs will all flash three (3) times indicating that activation is required.

7.3.1— Activation Sequence

NOTE: The generator is to be run with all appropriate panels in place, including during troubleshooting by a technician.

1. Locate and record the generator’s serial number. (Example: 7894562)
2. Contact Generac to obtain your activation code. Call - 1-888-9/ACTIVATE (922-8482, US & CA only) or go to www.activategen.com. For areas outside of the US & CA, please dial the international activation line 262-953-5155. The activation code, you will be given, consists of a sequence of six (6) button presses using the AUTO, OFF and SET EXERCISE buttons. See Figure 7-1. These **MUST** be entered in the exact and correct sequence in order to activate the generator.
3. Begin by holding the OFF button for 3 seconds. All the LEDs will flash twice telling you that the activation mode has begun. **NOTE:** You now have 20 seconds to correctly enter the press sequence or the unit will “time out” and not accept the activation code. If this occurs, you must begin the activation sequence again.
4. Enter the activation code by pressing the AUTO, OFF and SET EXERCISE buttons in the 6 press sequence you were given. (Example: AUTO / OFF / OFF / SET EXERCISE / SET EXERCISE / SET EXERCISE). The yellow maintenance LED will blink each time a button is pressed.
5. If the sequence is INCORRECTLY entered, the AUTO / OFF / MANUAL buttons will flash 3 times together. Return to Step 3 and continue.
6. If the sequence is CORRECTLY entered, all the LEDs will scroll from bottom to top 5 times. The OFF button will light. The activation process has been performed successfully and the generator is ready to operate.

7.3.2— Before Starting

Complete the following:

1. Ensure that the generator is OFF.
2. Set the generator’s main circuit breaker to the OFF (or OPEN) position.
3. Turn off all breakers that will be powered by the generator.
4. Check the engine crankcase oil level and, if necessary, fill to the dipstick FULL mark with the recommended oil. Do not fill above the FULL mark.
5. Check the fuel supply. Gaseous fuel lines must have been properly purged and leak tested in accordance with applicable fuel-gas codes. All fuel shutoff valves in the fuel supply lines must be open.

NOTE: During initial start up only, the generator may exceed the normal number of start attempts and experience an “overcrank” fault. This is due to accumulated air in the fuel system during installation. Reset the control board by pushing the OFF button twice, and restart up to two more times if necessary. If unit fails to start, contact a local dealer for assistance.

7.3.3— Setting Exercise Timer

This generator is equipped with an exercise timer. Once it is set, the generator will start and exercise every seven days, on the day of the week and at the time of day specified. During this exercise period, the unit runs for approximately 12 minutes and then shuts down. Transfer of loads to the generator output does not occur during the exercise cycle unless utility power is lost.

NOTE: The exercise timer does not correct for daylight savings time.

NOTE: The exerciser will only work in the AUTO mode, and will default to exercise weekly at the time the Control Panel was last powered on, unless this procedure is performed. The exercise function will need to be reset every time the 12 volt battery and T1 power to the generator are disconnected and then reconnected, and/or when the fuse is removed and T1 power is removed from the generator.

1. Place the generator in the AUTO mode.
2. Hold the SET EXERCISE Button for 3 seconds. The generator will start, run an exercise cycle, and confirm the setting. The exercise time must be established at the time you wish the exercise to take place.
3. The exercise time is now established. The generator will exercise each week at this time.

To CHANGE the exercise time once it has been set, hold the SET EXERCISE button on the generator for three (3) seconds at the time you wish the new exercise time to take place.

7.4 — Check Manual Transfer Switch Operation

Refer to the “Manual Transfer Operation” section of the owner’s manual for procedures.

⚠ DANGER!



Verify all voltage supplies have been turned OFF. Failure to turn off all power and voltage supplies can cause electrical shock or electrocution which can result in death or serious injury.

7.5 — Electrical Checks

Complete electrical checks as follows:

1. Ensure that the generator is OFF.
2. Set the generator’s main circuit breaker to the OFF (or OPEN) position.
3. Turn OFF all circuit breakers/electrical loads that will be supplied by the generator.
4. Turn on the utility power supply to the transfer switch using the means provided (such as a utility main line circuit breaker).

⚠ DANGER!



Contact with "hot" electrically charged components can cause electrical shock or electrocution. Failure to correctly follow this procedure can result in death or serious injury.

5. Use an accurate AC voltmeter to check utility power source voltage across transfer switch terminals N1 and N2. Nominal line-to-line voltage should be 240 volts AC. If it’s not, verify AC output and wiring from utility source to N1 and N2 lugs at transfer switch.
6. Check utility power source voltage across terminals N1 and the transfer switch neutral lug; then across terminal N2 and neutral. Nominal line-to-neutral voltage should be 120 volts AC. If it’s not, verify AC output and wiring from utility source to N1 and N2 lugs at transfer switch.
7. When certain that utility supply voltage is compatible with transfer switch and load circuit ratings, turn OFF the utility power supply to the transfer switch.
8. On the generator panel, push the MANUAL button. The engine should crank and start.
9. Let the engine warm up for about five minutes to allow internal temperatures to stabilize. Then, set the generator’s main circuit breaker to its ON (or closed) position.

⚠ DANGER!

Contact with "hot" electrically charged components can cause electrical shock or electrocution. Failure to correctly follow this procedure can result in death or serious injury.

10. Connect an accurate AC voltmeter and a frequency meter across transfer switch terminal lugs E1 and E2. Voltage should be 236-240 at a frequency of 62-63 Hertz at no load. If it's not, verify that the MLCB is closed and verify AC output and frequency (Hertz or Hz) at the MLCB. Also verify wiring from generator to E1 and E2 lugs at transfer switch.
11. Connect the AC voltmeter test leads across terminal lugs E1 and neutral; then across E2 and neutral. In both cases, voltage reading should be 118-120 volts AC. If it's not, verify that the MLCB is closed and verify AC output between the E1 and E2 of the MLCB and Neutral at the generator. Also, verify wiring from generator to E1, E2 and Neutral lugs at transfer switch.
12. Set the generator's main circuit breaker to its OFF (or OPEN) position.
13. Push the generator's OFF button. The engine should shut down.

NOTE: It is important not to proceed until certain that generator AC voltage and frequency are correct and within the stated limits.

7.6 — Generator Tests Under Load

To test the generator set with electrical loads applied, proceed as follows:

1. Ensure that the generator is OFF.
2. Turn OFF all breakers/electrical loads that will be powered by the generator.
3. Turn OFF the utility power supply to the transfer switch, using the means provided (such as a utility main line circuit breaker).

⚠ DANGER!

Verify all voltage supplies have been turned OFF. Failure to turn off all power and voltage supplies can cause electrical shock or electrocution which can result in death or serious injury.

4. Manually set the transfer switch to the STANDBY position, i.e., load terminals connected to the generator's E1/E2 terminals. The transfer switch operating lever should be down.
5. Push the generator's MANUAL button. The engine should crank and start immediately.
6. Let the engine stabilize and warm up for a few minutes.
7. Set the generator's main circuit breaker to its ON (or CLOSED) position. Loads are now powered by the standby generator.
8. Turn ON the circuit breaker/electrical loads that are powered by the generator one by one.
9. Connect a calibrated AC voltmeter and a frequency meter across terminal lugs E1 and E2. Voltage should be approximately 240 volts and frequency should be 60 Hz. If the voltage and frequency are rapidly dropping as the loads are applied, the generator may be overloading or there may be a fuel issue. Check amperage value of loads and/or fuel pressure.
10. Let the generator run at full rated load for 20-30 minutes. Listen for unusual noises, vibration or other indications of abnormal operation. Check for oil leaks, evidence of overheating, etc.
11. Verify gas pressure while under full load.
12. When testing under load is complete, turn OFF electrical loads.
13. Set the generator's main circuit breaker to the OFF (or open) position.
14. Let the engine run at no-load for 2-5 minutes.
15. Push the generator's OFF button. The engine should shut down.

7.7 — Checking Automatic Operation

To check the system for proper automatic operation, proceed as follows:

1. Ensure that the generator is OFF.
2. Install front cover of the transfer switch.
3. Turn ON the utility power supply to the transfer switch, using the means provided (such as a utility main line circuit breaker).

NOTE: Transfer Switch will transfer back to utility position.

4. Set the generator's main circuit breaker to its ON (or CLOSED) position.
5. Push the generator's AUTO button. The system is now ready for automatic operation.
6. Turn OFF the utility power supply to the transfer switch.

With the generator ready for automatic operation, the engine should crank and start when the utility source power is turned OFF after a 10 second delay (factory default setting). After starting, the transfer switch should connect load circuits to the standby side after a five (5) second delay. Let the system operate through its entire automatic sequence of operation.

NOTE: Loss of utility power will cause either the AUTO or OFF or MANUAL buttons to flash. Whichever mode the generator is in at the time of utility loss.

With the generator running and loads powered by generator AC output, turn ON the utility power supply to the transfer switch. The following should occur:

- After approximately 15 seconds, the switch should transfer loads back to the utility power source.
- Approximately one minute after re-transfer, the engine should shut down.

7.8 — Installation Summary

1. Ensure that the installation has been properly performed as outlined by the manufacturer and that it meets all applicable laws and codes.
2. Test and confirm proper operation of the system as outlined in the appropriate installation and owner's manuals.
3. Educate the end-user on the proper operation, maintenance and service call procedures.

IMPORTANT! If the end user ever finds it necessary to turn the generator off during prolonged utility outages to perform maintenance or conserve fuel, educate them on these simple, but important steps:

To turn the generator OFF (while running in AUTO and online):

1. Turn OFF (or OPEN) the main Utility disconnect.
2. Turn OFF (or OPEN) the Main Line Circuit Breaker (MLCB) on the generator and allow the generator to cool down for one minute.
3. Turn the generator OFF.

To turn the generator back ON:

1. Put the generator back into AUTO and allow to start and warm-up for a few minutes.
2. Turn ON (or CLOSE) the MLCB on the generator.

The system will now be operating in its automatic mode. The main utility disconnect can be turned ON (or CLOSED), but to shut the unit off, this complete process must be repeated.

This page intentionally left blank.

Section 8 *Troubleshooting*

8.1 — Troubleshooting Guide

Problem	Cause	Correction
Engine will not crank.	<ol style="list-style-type: none"> 1. Fuse blown. 2. Loose, corroded or defective battery cables. 3. Defective starter contact. 4. Defective starter motor. 5. Dead Battery. 	<ol style="list-style-type: none"> 1. Correct short circuit condition by replacing 7.5 Amp fuse in generator control panel. 2. Tighten, clean or replace as necessary.* 3. *See #2. 4. *See #2. 5. Charge or replace battery.
Engine cranks but will not start.	<ol style="list-style-type: none"> 1. Out of fuel. 2. Defective fuel solenoid (FS). 3. Defective spark plug(s). 4. Valve lash out of adjustment. 5. Cold weather condition. 	<ol style="list-style-type: none"> 1. Replenish fuel / turn on fuel valve. 2. * 3. Clean, re-gap or replace plug(s). 4. Adjust valve lash. 5. Install recommended cold weather kit.
Engine starts hard and runs rough.	<ol style="list-style-type: none"> 1. Air cleaner plugged or damaged. 2. Defective spark plug. 3. Fuel pressure incorrect. 4. Wrong fuel jet used. 	<ol style="list-style-type: none"> 1. Check / replace air cleaner. 2. Clean, re-gap or replace plug. 3. Confirm fuel pressure to regulator is 10-12" water column (19-22mm mercury) for LP, and 3.5 - 7" water column (9-13mm mercury) for natural gas. 4. Change the Fuel Jet to the recommended part for the fuel used.
Generator is set to OFF, but the engine continues to run.	<ol style="list-style-type: none"> 1. Control panel wired incorrectly. 2. Defective control board. 	<ol style="list-style-type: none"> 1. Repair wiring.* 2. Replace control panel.*
There is no AC output from generator.	<ol style="list-style-type: none"> 1. Main line circuit breaker is in the OFF (or OPEN) position. 2. Generator internal failure. 	<ol style="list-style-type: none"> 1. Reset circuit breaker to ON (or CLOSED). 2. *
There is no transfer to standby after utility source failure.	<ol style="list-style-type: none"> 1. Main line circuit breaker is in the OFF (or OPEN) position. 2. Defective transfer switch coil. 3. Defective transfer relay. 4. Transfer relay circuit open. 5. Defective control logic board. 	<ol style="list-style-type: none"> 1. Reset circuit breaker to ON (or CLOSED) position. 2. * 3. * 4. * 5. *
Unit consumes large amounts of oil.	<ol style="list-style-type: none"> 1. Engine over filled with oil. 2. Engine breather defective. 3. Improper type or viscosity of oil. 4. Damaged gasket, seal or hose. 	<ol style="list-style-type: none"> 1. Adjust oil to proper level. 2. * 3. See "Engine Oil Recommendations". 4. Check for oil leaks.
* Contact an independent Authorized Service Dealer for assistance.		

This page intentionally left blank.

Section 9 Quick Reference Guide

9.1 — System Diagnosis

Problem	Things to Check	Active Alarm	Solution
Unit running in AUTO but no power in house.	Check MLCB	NONE	Check MLCB. Contact servicing dealer if MLCB is in the ON position.
Unit shuts down during operation.	Check for alarms	HIGH TEMPERATURE	Check ventilation around the generator, intake, exhaust and rear of generator. If no obstruction contact servicing dealer.
Unit was running and shut down. Attempts to restart.	Check for alarms	RPM SENSE LOSS	Clear alarm and remove household loads from the generator. Put back in AUTO and restart. If problem returns, contact servicing dealer to investigate possible fuel issue.
After activation, unit will not start in AUTO with utility loss.	See if unit is activated	NOT ACTIVATED	Refer to activation section in Owner's Manual.
Unit will not start in AUTO with utility loss.	Check for alarms	LOW OIL LEVEL	Check oil level. Add oil per Owner's Manual. Contact servicing dealer if oil level is correct.
Unit will not start in AUTO with utility loss.	Check for alarms	RPM SENSE LOSS	Clear alarm. Contact servicing dealer if battery is GOOD. Replace battery if battery problem is displayed.
Unit will not start in AUTO with utility loss.	Check for alarms	OVERCRANK	Check fuel line shutoff valve is in the ON position. Clear alarm. Attempt to start the unit in MANUAL. If it does not start or starts and runs rough, contact servicing dealer.
Unit will not start in AUTO with utility loss.	Check for alarms	NO LEDs LIT	Check ATO 7.5 Amp ATO [®] fuse. Replace with same type fuse if bad. Contact servicing dealer if fuse is good.
Unit will not start in AUTO with utility loss.	Check for alarms	OVERSPEED UNDERSPEED	Contact servicing dealer.
Unit will not start in AUTO with utility loss.	Check for alarms	WIRING ERROR	Contact servicing dealer.
Control panel indicates battery problem.	Check for additional information	BATTERY PROBLEM	Contact servicing dealer.
Control panel indicates charging problem.	Check for additional information	CHARGER PROBLEM	Contact servicing dealer
Control panel indicates break-in maintenance due	Check for additional information	BREAK IN MAINTENANCE DUE	Perform break in maintenance. Clear Maintenance Due light.
Control panel indicates maintenance due	Check for additional information	1 YEAR / 100 HOUR MAINTENANCE DUE	Perform scheduled maintenance. Clear Maintenance Due light.
Utility present. Active mode LED (AUTO/MANUAL/OFF) is flashing.	Check utility sense lines/ utility disconnect	NONE	Contact servicing dealer. Close utility disconnect.

This page intentionally left blank.

Section 10 Accessories

10.1 — Descriptions

Accessory	Description
Cold Weather Kit	Required in areas where temperatures regularly fall below 32 °F (0 °C).
Scheduled Maintenance Kit	Includes all pieces necessary to perform maintenance on the generator along with oil recommendations.
Auxiliary Transfer Switch Lockout	Enables any of the transfer switches to completely lock out one large electrical load by tying into its control system.
Mobile Link™	Provides a personalized web portal that displays the generator's status, maintenance schedule, event history and much more. This portal is accessible via computer, tablet or smart phone. Sends emails and/or text notifications the moment there is any change in the generator's status. Notification settings can be customized to what type of alert is sent and how often. For more information visit www.standbystatus.com .
Wireless Local Monitor	Completely wireless and battery powered, the Wireless Monitor provides you with instant status without ever leaving the house. Status lights (red, yellow and green) alert owners when the generator needs attention. Magnetic backing permits refrigerator mounting and gives a 600 foot line of sight communication.
Touch-Up Paint Kit	Very important to maintain the look and integrity of the generator enclosure. This kit includes touch-up paint and instructions.
Extended Warranty Coverage	Extend your generator's warranty coverage by purchasing the 5 year extended warranty coverage. Covers 5 years of both parts and labor. Extended coverage can be purchased within 12 months of the end-users purchase date. This extended coverage is applicable to registered units and end-user proof of purchase must be available upon request. Available for Generac®, Guardian® and Centurion® products. Not available for Corepower™ and EcoGen products or all international purchases.

NOTE: Contact a Dealer for additional information on accessories.

This page intentionally left blank.

Section 11 Diagrams

11.1 — Installation Diagram

Drawing 0K8350 Rev. A page 1

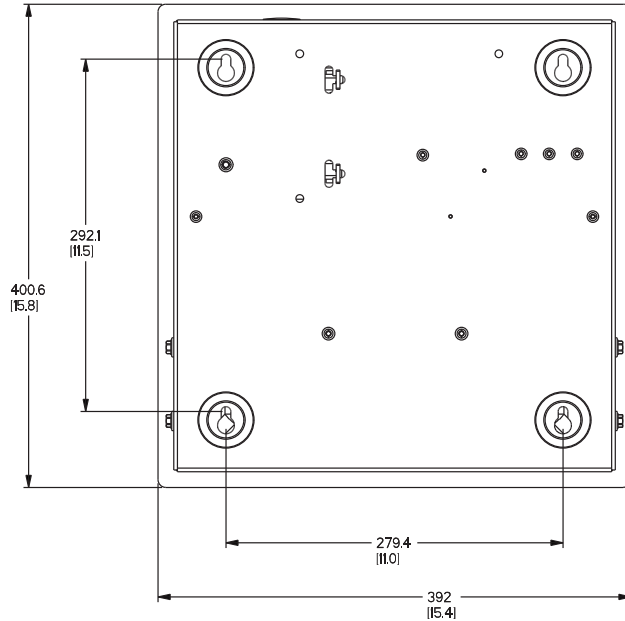

TRANSFER SWITCH
7kW
(IF SUPPLIED)

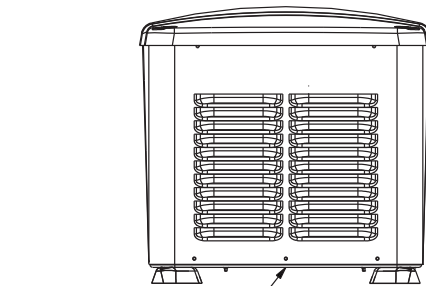

LIFT UNIT BY CENTER
CLEAR FROM MOUNTING FEET

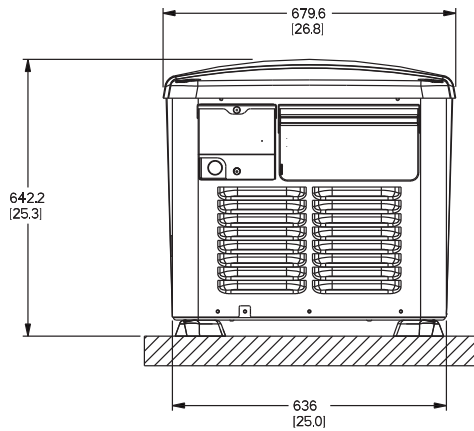

LEFT SIDE VIEW

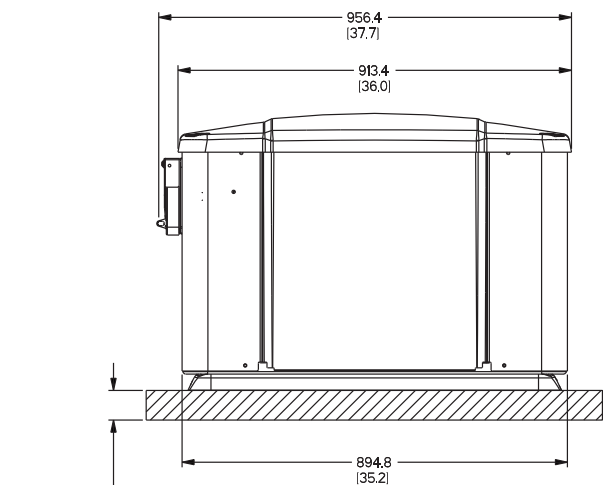

FRONT VIEW

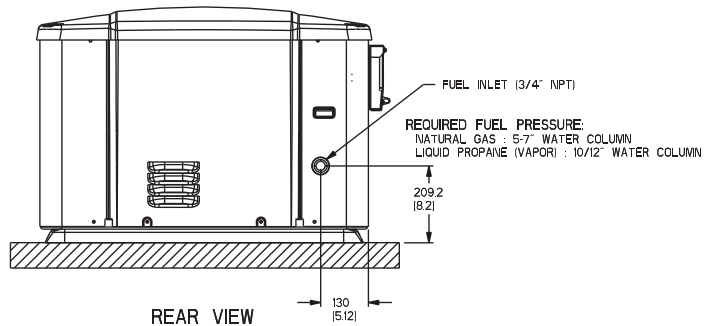
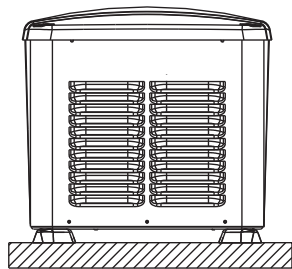
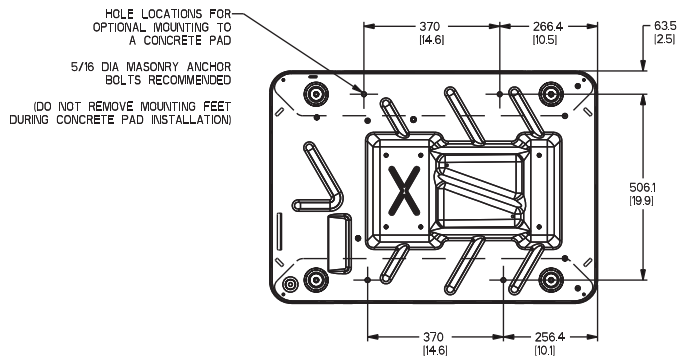
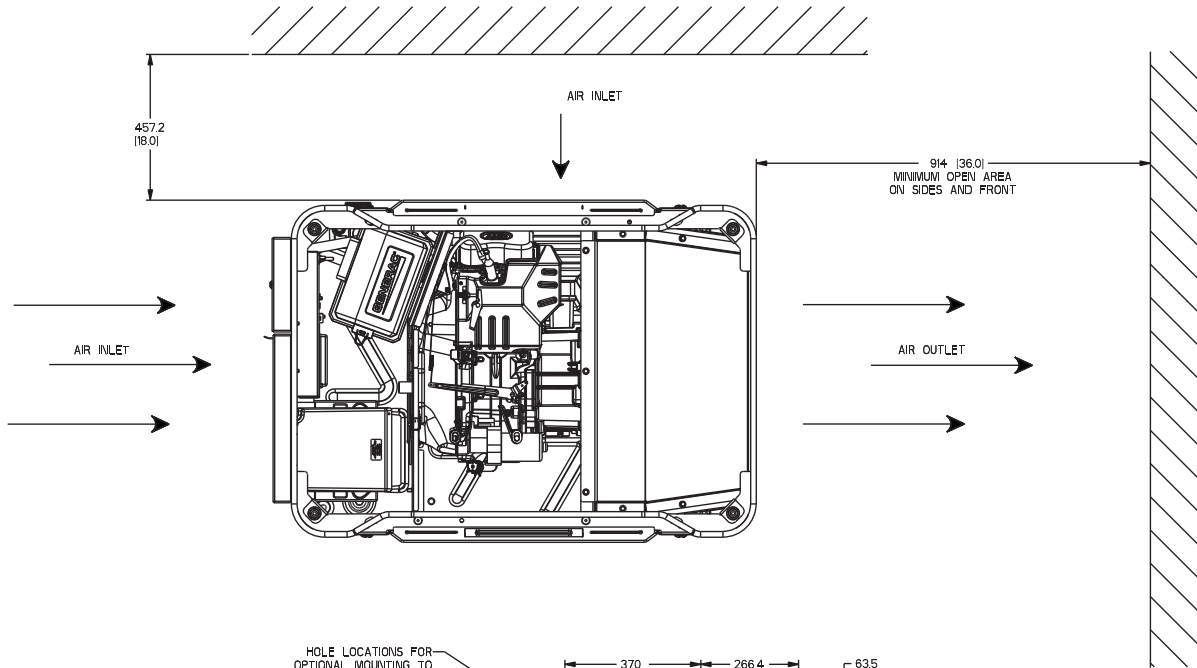

11.2 — Wiring Diagram

Drawing 0K7328 Rev. B page 1

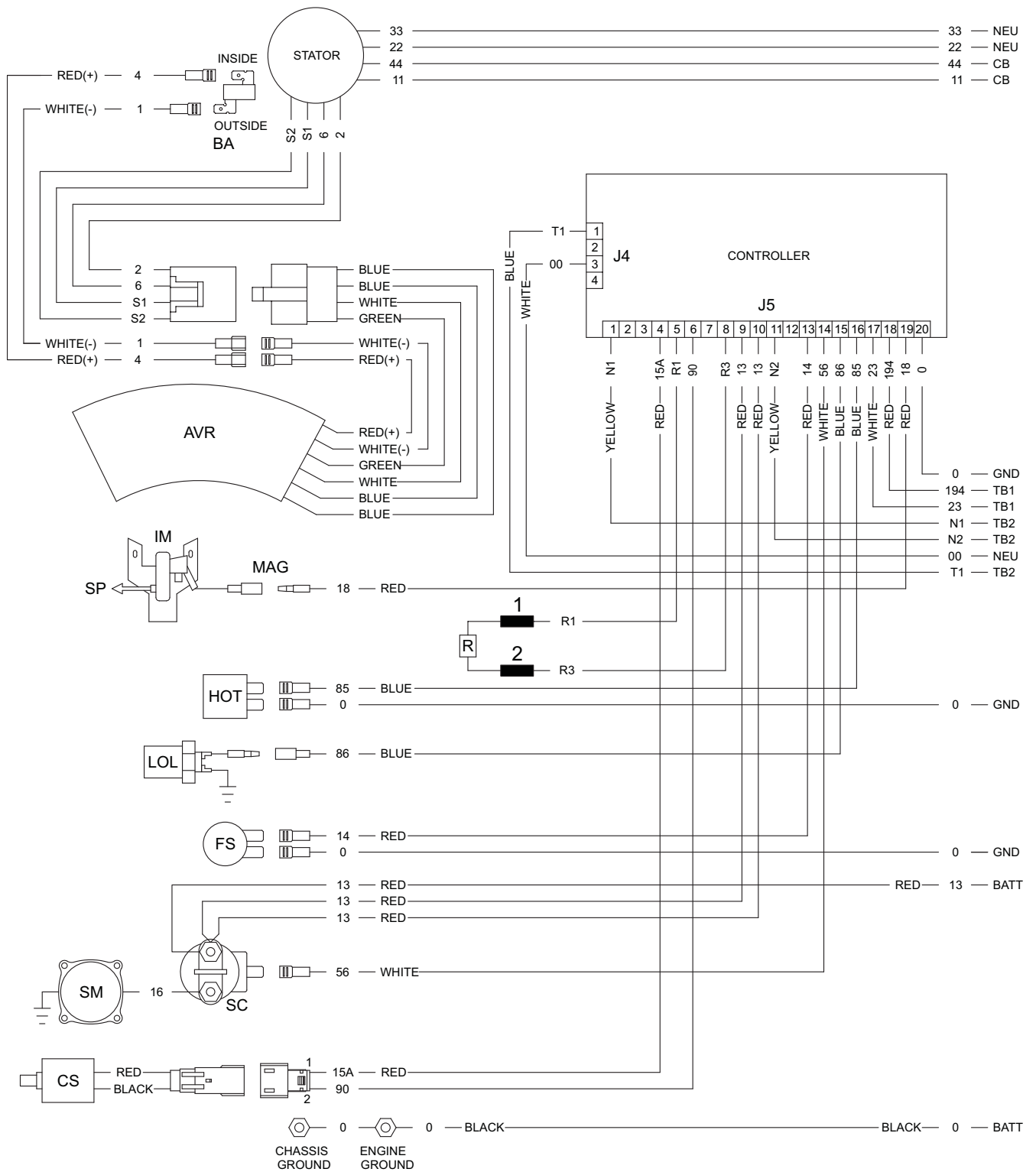

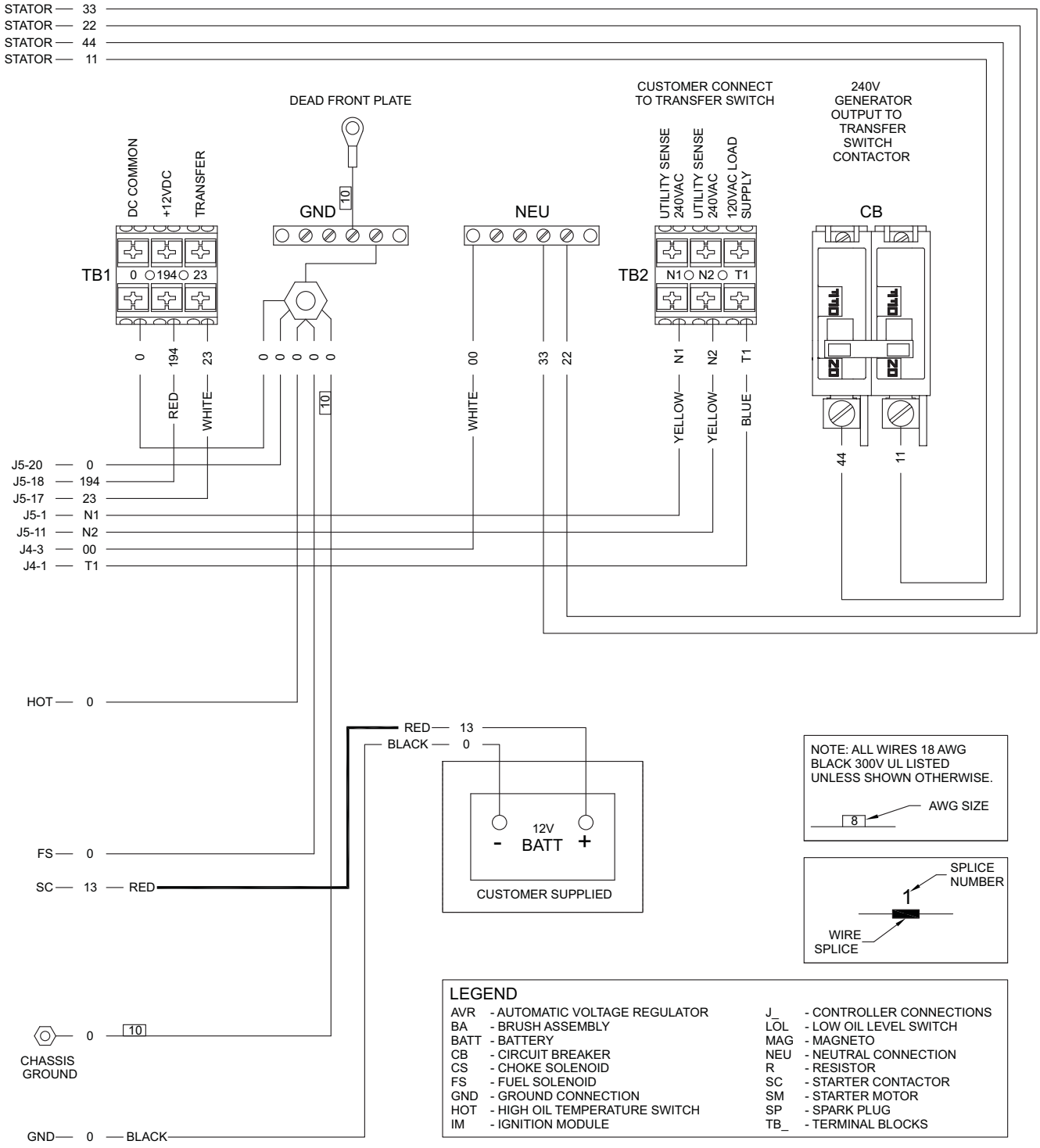

Drawing 0K7328 Rev. B page 3

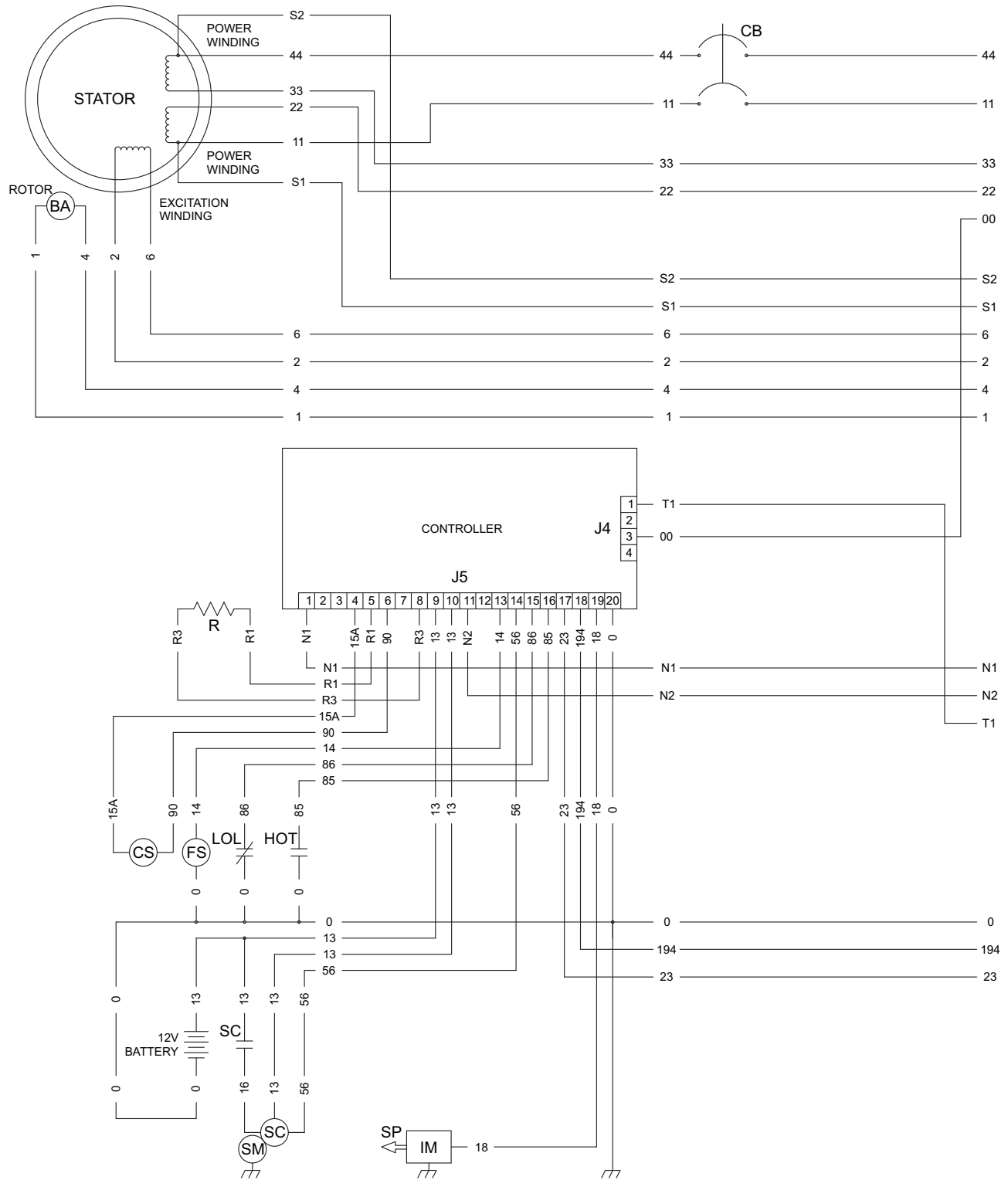

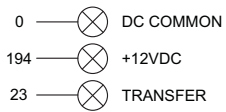
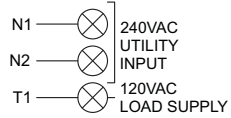
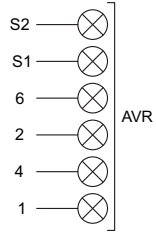
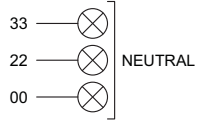
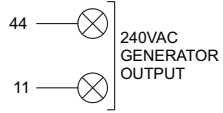

LEGEND

AVR - AUTOMATIC VOLTAGE REGULATOR	J - CONTROLLER CONNECTIONS
BA - BRUSH ASSEMBLY	LOL - LOW OIL LEVEL SWITCH
CB - CIRCUIT BREAKER (MAIN OUTPUT)	R - RESISTOR
CS - CHOKE SOLENOID	SC - STARTER CONTACTOR
FS - FUEL SOLENOID	SM - STARTER MOTOR
HOT - HIGH OIL TEMPERATURE SWITCH	SP - SPARK PLUG
IM - IGNITION MODULE	

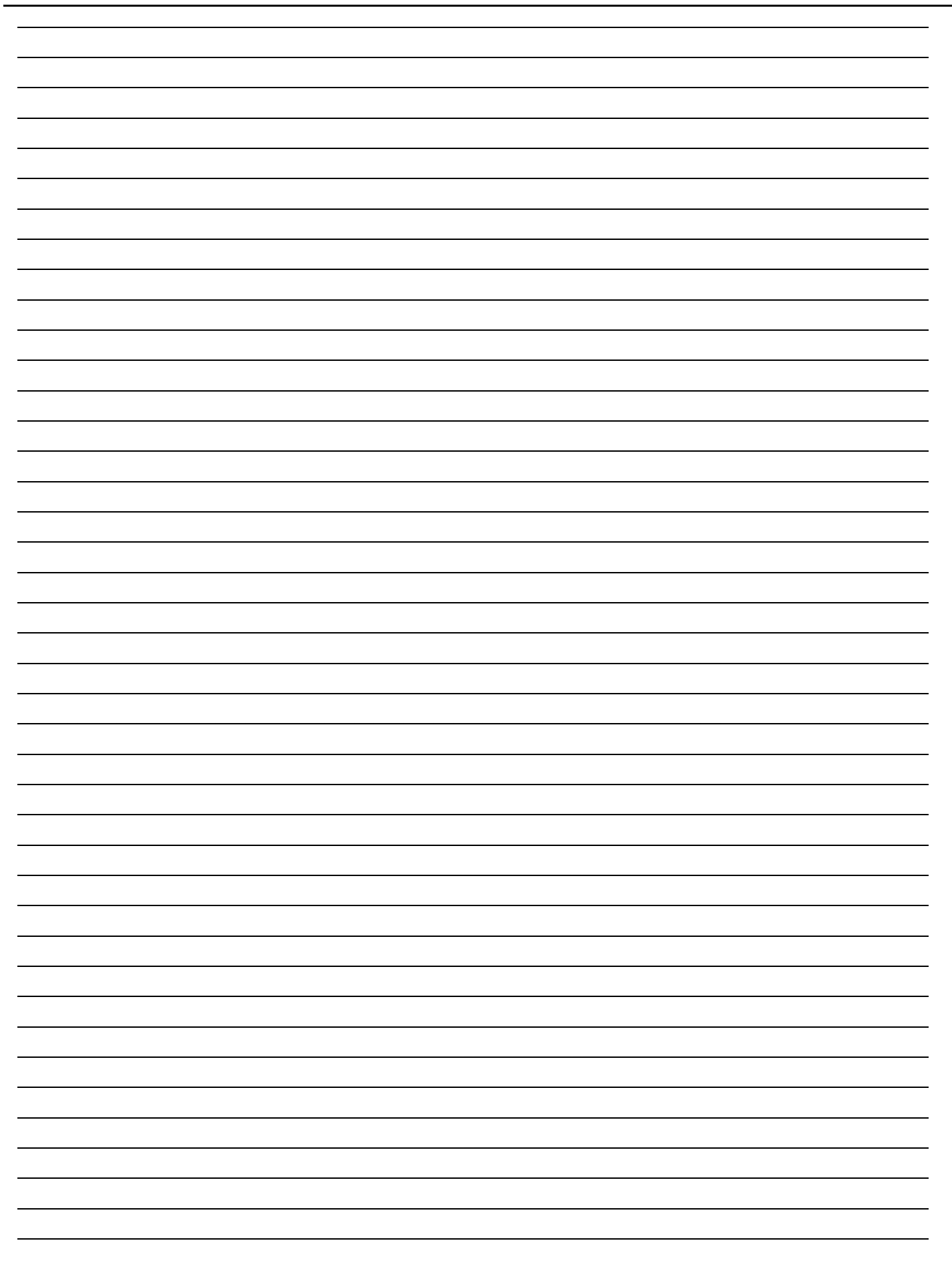



Part No. 0K6022 Rev. B 09/24/2014 Printed in USA
© Generac Power Systems, Inc. All rights reserved
Specifications are subject to change without notice.
No reproduction allowed in any form without prior written
consent from Generac Power Systems, Inc.

Generac Power Systems, Inc.
S45 W29290 Hwy. 59
Waukesha, WI 53189
1-888-GENERAC (1-888-436-3722)
generac.com