

# INSTALLER'S GUIDE

18-HE97D1-2

ALL phases of this installation must comply with NATIONAL, STATE AND LOCAL CODES

## R-410A TXV Kit:

4AYTXVH3G2436A  
4AYTXVH3G4248A  
4AYTXVH3G6000A

Fits Models:

4GXC/4MXC Coils and  
TMM4 Air Handlers

**IMPORTANT** — This document is customer property and is to remain with this unit. Please return to service information pack upon completion of work.

### General Information

The TXV Kit is intended only for use with specific models of the 4GXC/4MXC coils and TMM4 air handlers.

The Thermostatic Expansion Valve (TXV) Kit is used to increase the efficiency and ratings.

**NOTE: This TXV kit is for R-410A refrigerant and must always match the refrigerant type listed on the name plate of the outside unit.**

### Kit Identification

Confirm the TXV Kit type that is approved to be used with the coil or air handler. See Table 1 to verify proper kit and product model number.

### Inspection

Check carefully for any shipping damage. Any damage must be reported to, and claims made against the transportation company immediately. Any missing parts should be reported to your supplier at once and replaced with authorized parts only.

## Coil TXV Kit Contents

Inspect contents for damage or missing items.

Each kit contains:

No.	Qty	Description
1	1	R-410A Expansion Valve
2	3	Teflon® O-ring
3	1	Installer's Guide (Not shown)
4	1	Bulb/TXV Insulation
5	1	Cable Tie
6	1	Inlet Tube Assembly
7	1	Sensing Bulb Strap
8*	1	Outlet Tube Assembly
9	1	Vapor Line Adapter

\* Note: Item 8 is only used with TMM4 air handler

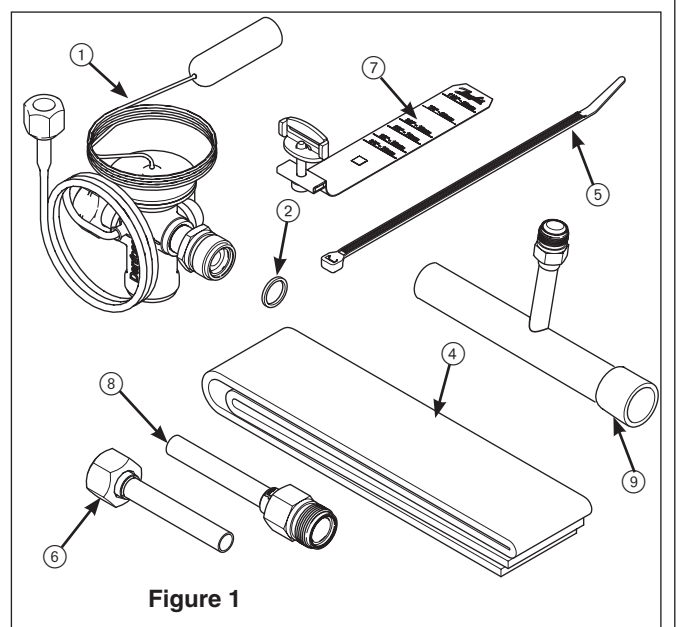

Figure 1

**Installation Instructions for 4GXC/4MXC coils**

1. Remove the mechanical fitting cap on the liquid line entering the coil.
2. Remove the existing piston, the piston housing, and the two (2) O-rings shown in Figure 2 inset, from the mechanical fitting in the liquid line.

**NOTE: Before the TXV is installed, remove the piston.**

**NOTE: Remove the existing Teflon O-rings from the existing liquid line connections. New supplied O-rings must be used between the TXV fittings and line fittings.**

3. Braze the vapor line adapter to the coil refrigerant gas line. The fitting on the adapter must point upward to avoid interference with the TXV.

**IMPORTANT: Wrap the adapter around the equalizer port connection with a wet rag when brazing connections to protect the braze alloy connecting the the equalizer port tube to the adapter.**

4. Braze the field refrigerant gas line to the vapor line adapter.
5. Braze the field liquid line to the liquid line tube assembly.

**TXV Installation Instructions**

6. DO NOT oil threads. Before installing the TXV, install one O-ring on the Liquid Line Fitting. Install the other O-ring on the Inlet Tube Assembly. See Figure 3.
7. Connect the TXV by hand to ensure proper mating of threads. Tighten until bodies "bottom" or a definite resistance is felt. The valve will only fit in one direction of flow. Use a back-up wrench and tighten an additional 1/6 turn past finger tight.
8. Attach the Inlet Tube Assembly to the TXV. Use a back-up wrench and tighten 1/6 turn past finger tight.

**IMPORTANT: Correct tightening of the couplings is very important. Under- or over-tightening may result in a coupling leak.**

**IMPORTANT: Finger tighten then use a back-up wrench to tighten and additional 1/6 turn.**

9. Install the Equalizer Line, hand-tighten until flare bottoms, then use a back-up wrench to tighten securely an additional 1/6 turn.

**IMPORTANT: Replacing the liquid line filter drier is recommended if system has been commissioned. This is not necessary if this kit is being installed on a new coil.**

10. Use the supplied bulb strap to attach the sensing bulb onto a straight section of the refrigerant gas line. See Figure 5 for instructions on attaching the bulb strap. In some cases, the bulb strap is required when the new bulb size is different from the existing sensing bulb.

The entire length of the bulb must be in firm contact with the refrigerant gas line. The remote bulb tubing must not be allowed to touch a surface colder than the remote bulb location. The remote bulb tubing must be isolated from rubbing all other components

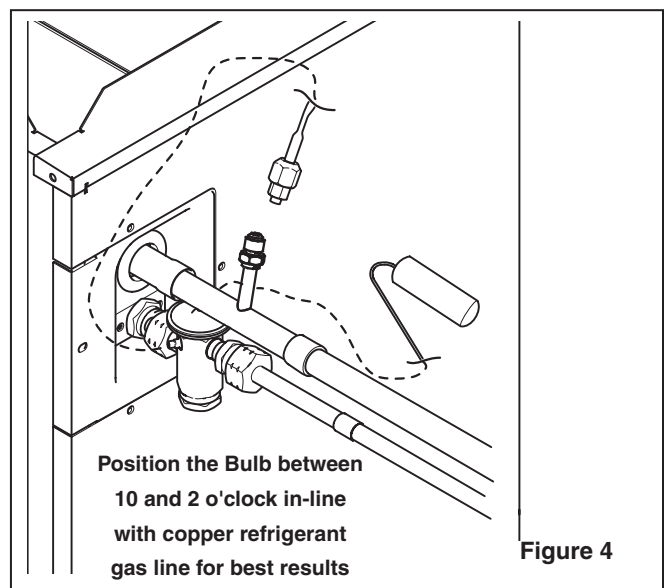
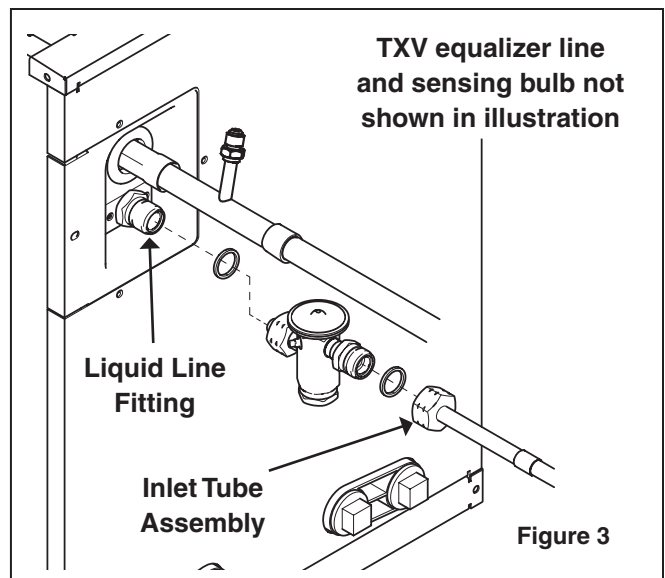
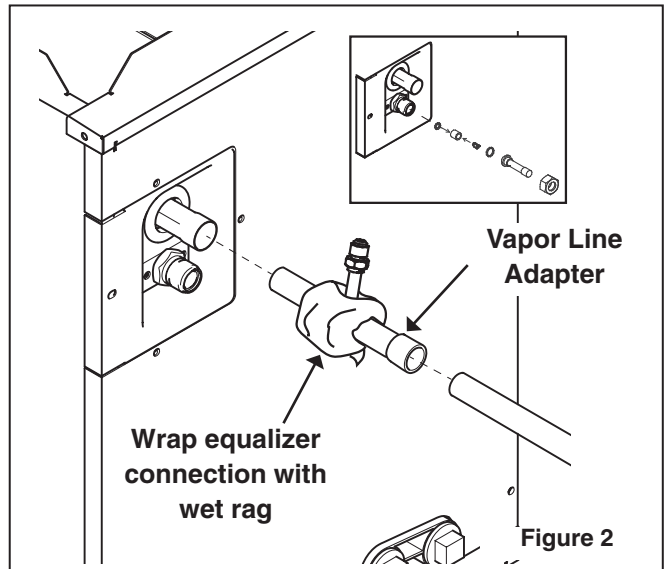

11. Wrap the TXV and the sensing bulb with supplied insulation.
12. Use the cable tie to secure the extra lengths of the capillary tubing of the equalizer and sensing bulb.
13. Pressurize with dry nitrogen and leak test all joints to insure no leaks exist. Evacuate system to a minimum of 500 microns.
14. Open valves to outdoor unit if pumped-down or charge to a minimum of 50 psig static pressure. Start system and charge to appropriate level per the charging method recommended in the Outdoor Unit Installer's Guide.

**Make contact tight.**

- Clean the suction line thoroughly before clamping the bulb in place.
- Bulb has to be mounted in tight contact with pipe. (TIP: Shine a flashlight between bulb and suction line, realign the bulb if light is visible.)
- Align the bulb with copper refrigerant gas line and position at 10 or 2 o'clock.
- Pull the bulb strap tight around the copper refrigerant gas line and bulb before tightening the screw.
- After tightening, it should not be possible to move the bulb by hand.

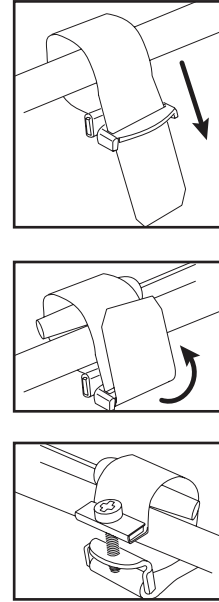

**Figure 5**

**Installation Instructions for TMM4 air handlers**

1. Pull back the insulation at the fitting connection. See Figure 6.
2. Using a back-up wrench, loosen the mechanical fittings.
3. Remove the piston from the mechanical fitting in liquid line. Remove and discard the O-ring.

**NOTE: Remove the piston.**

4. Install new O-ring on fitting. O-ring is supplied in kit.
5. Using a back-up wrench, reattach the fittings. Tighten until bodies "bottom" or a definite resistance is felt. The valve will only fit in one direction of flow. Use a back-up wrench and tighten an additional 1/6 turn.
6. Reinstall the insulation over the fittings.

**IMPORTANT: Correct tightening of the couplings is very important. Under- or over-tightening may result in a coupling leak.**

7. Braze the outlet tube to the unit (male fitting).
8. Braze the inlet tube assembly (female fitting) to the field refrigerant line.
9. Braze vapor line adapter to vapor line making sure Schrader valve is towards the left side when viewing the front of the unit.

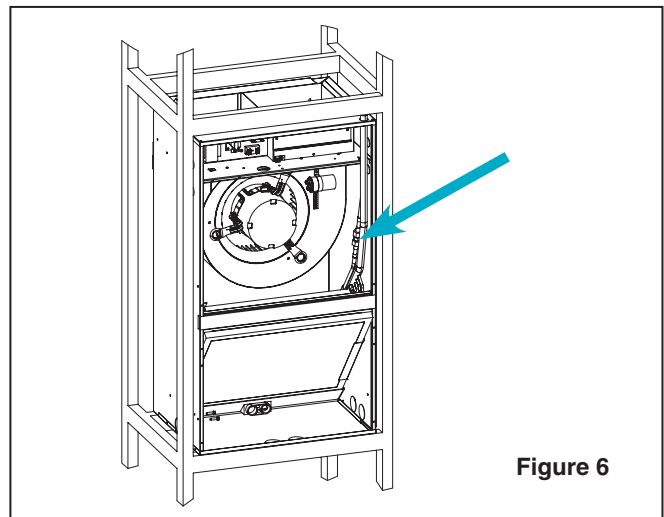

**Figure 6**

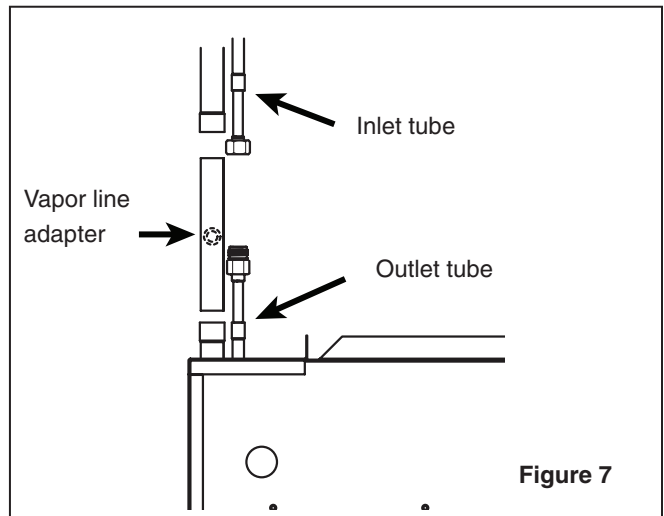

**Figure 7**

TXV Installation Instructions

- DO NOT oil threads. To install the TXV, install one new O-ring over the Distributor Fitting (Figure 8). Install the other new O-ring over the Liquid Line Fitting and connect the adapters by hand to ensure proper mating of threads. The new O-rings are supplied in the kit. Tighten until bodies “bottom” or a definite resistance is felt. The valve will only fit in one direction of flow. Use a back-up wrench and tighten an additional 1/6 turn.

**IMPORTANT: Correct tightening of the couplings is very important. Under- or over-tightening may result in a coupling leak.**

**IMPORTANT: The arrow on the TXV will point downward towards unit when installed correctly.**

- Install the Equalizer Line, hand-tighten until flare bottoms, then use a back-up wrench to tighten an additional 1/6 turn.
- Orient the sensing bulb with the tube exiting out the top to the vapor line extension onto a straight section of the refrigerant gas line as shown in Figure 9. Use the supplied TXV bulb strap shown in Figure 5 to secure the bulb in place. In some cases, the bulb strap is required when the new bulb size is different from the existing sensing bulb.

The entire length of the bulb must be in firm contact with the refrigerant gas line. The remote bulb tubing must not be allowed to touch a surface colder than the remote bulb location. The remote bulb tubing must be isolated from rubbing all other components.

- See the coil TXV installation on page 3 and follow Steps 11-14 to complete the installation.

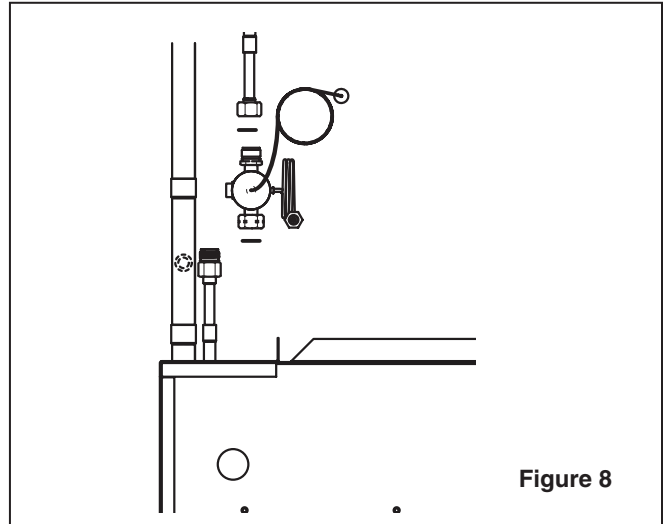

Figure 8

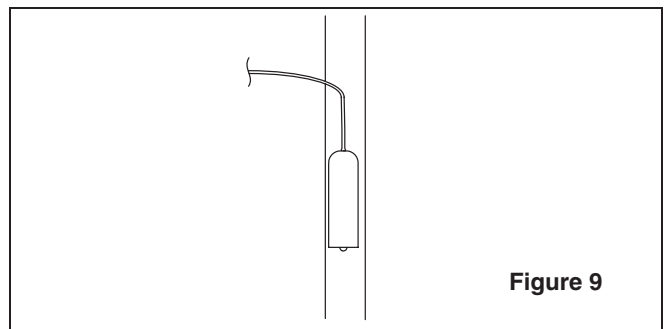

Figure 9

**TABLE 1** Coil and Air Handler TXV Matches

Coil Model	Tonnage	R-410A TXV kit (if required)
4GXC/4MXC	1.5 - 3.0	4AYTXVH3G2436A
	3.5 - 4.0	4AYTXVH3G4248A
	5.0	4AYTXVH3G6000A
Air Handler Model	Tonnage	R-410A TXV kit (if required)
TMM4	1.5 - 3.0	4AYTXVH3G2436A