

No. 674,874.

Patented May 28, 1901.

H. S. PALMER.
CONCRETE WALL FOR BUILDINGS.

(Application filed Mar. 21, 1900.)

(No Model.)

2 Sheets—Sheet 1.

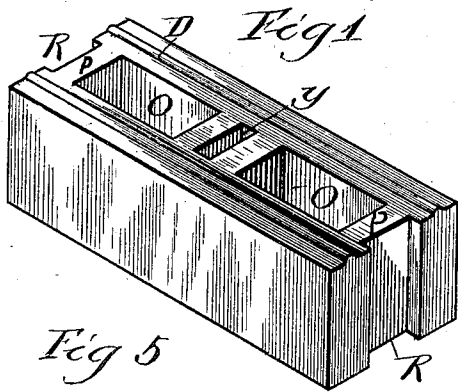

Fig 1

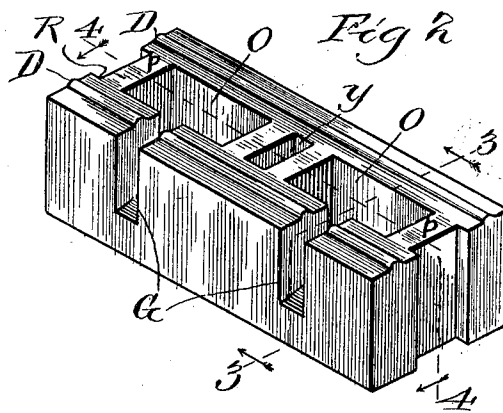

Fig 2

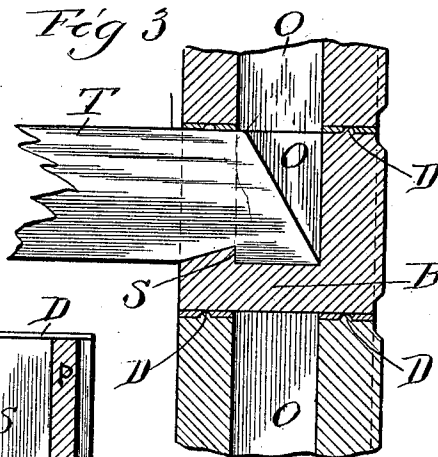
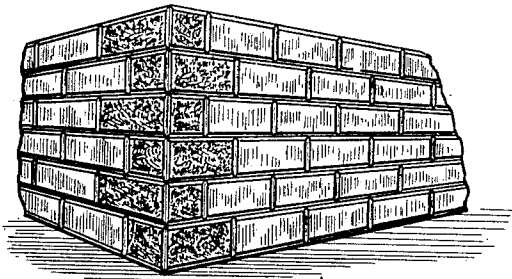

Fig 3

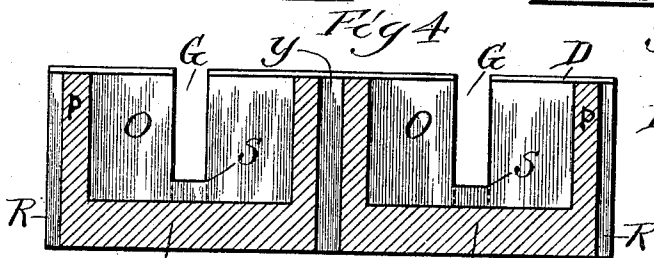

Fig 5

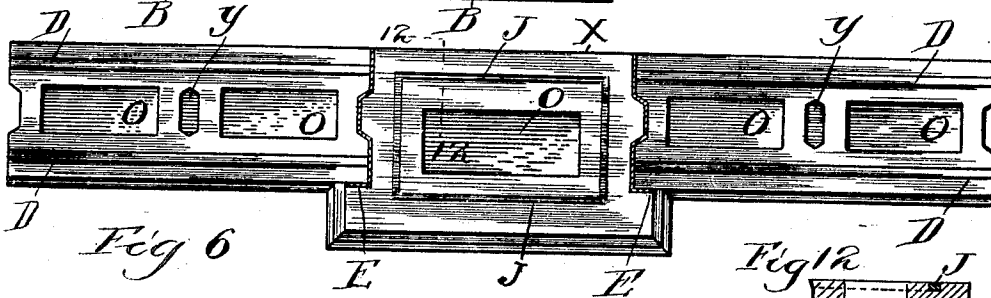

Fig 6

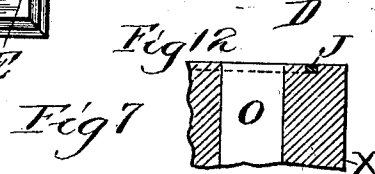
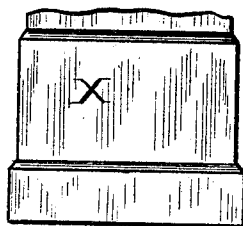

Fig 7

Witnesses
 W. C. Collier
 Wm. Geiger



Inventor
 Harmon S. Palmer

No. 674,874.

Patented May 28, 1901.

H. S. PALMER.
CONCRETE WALL FOR BUILDINGS.

(Application filed Mar. 21, 1900.)

(No Model.)

2 Sheets—Sheet 2.

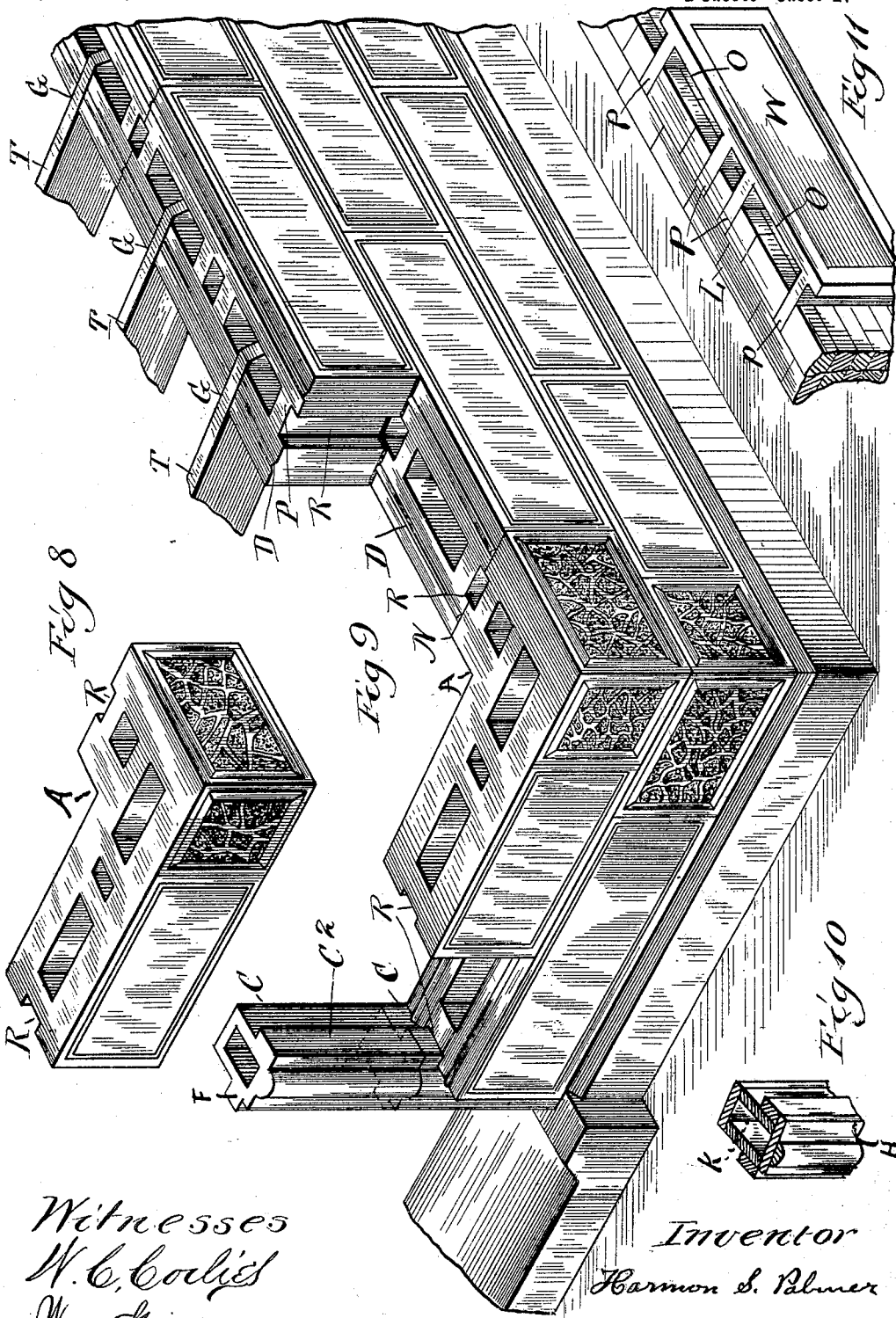

Witnesses
W. C. Collier
Wm. Geiger

Inventor
Harmon S. Palmer

UNITED STATES PATENT OFFICE.

HARMON S. PALMER, OF CHICAGO, ILLINOIS.

CONCRETE WALL FOR BUILDINGS.

SPECIFICATION forming part of Letters Patent No. 674,874, dated May 28, 1901.

Application filed March 21, 1900. Serial No. 9,631. (No model.)

To all whom it may concern:

Be it known that I, HARMON S. PALMER, a citizen of the United States, residing at Chicago, in the county of Cook and State of Illinois, have invented certain new and useful Improvements in Concrete Walls for Buildings, of which the following is a specification.

My improvement relates to the construction of buildings; and the object is to simplify, cheapen, and to produce stronger buildings as well as more efficient in protecting from the elements, and relates to that class usually made of concrete or similar material in which separate blocks are united to make the desired wall.

With this end in view my invention consists in certain features of construction and combination of parts, as will be hereinafter set forth, and pointed out in the claims.

In the accompanying drawings, which form part of this specification, Figure 1 is a perspective view of one of my building-blocks designed to be laid with others in position to form the whole and complete wall. Fig. 2 is a similar block, but provided with the openings to receive the floor-joists and a bottom on which the joists rest. Fig. 3 is a detailed vertical section taken through the line 3 3 of Fig. 2, but showing the floor-joists in position. Fig. 4 is a longitudinal section taken on the line 4 4, Fig. 2, but with the joists removed. Fig. 5 is the perspective view of the outside corner of a completed wall. Fig. 6 is a detailed plan view showing the building-blocks as applied to a chimney or pilaster. Fig. 7 is a detailed elevation of a pilaster or chimney removed. Fig. 8 is a detailed perspective view of one of the corner-blocks as shown in Fig. 9. Fig. 9 is a perspective detail view with the several blocks and parts assembled, showing the relation that each bears to the other. Fig. 10 shows a modified form of the door or window frame which is shown in Fig. 9, and the same may be made of wood in place of stone or concrete. Fig. 11 shows a modified form of building these walls with one side concrete and the other side of brick or other material, which is done by splitting the block, Fig. 1, and substituting for the discarded side some other material. Fig. 12 is a cross-section of Fig. 6 on the line 12 12.

In all buildings constructed of soft and por-

ous material—such as brick, sandstone, &c.—a great detriment exists in the absorbent nature of the material and the long time required to dry out such walls after heavy rains, and the unsanitary, damp, and musty condition of such walls after years of service renders any method to prevent or better such conditions valuable. In my method advantage is taken of a cavity or opening O, molded vertically through the concrete block a few inches from the side which forms the outside of the building. By this means a thin wall of stone is made to receive the rain and dampness which is prevented from penetrating to the inside by this opening O, and thus it will be understood that a few hours of sunshine will remove all dampness, leaving the walls dry and the building in a sanitary and healthy condition, and as a further aid to this end this opening O may be used as a ventilator, which can be connected with every room in the house, thereby securing a circulation of air of the most desirable kind. In order to prevent the dampness and frost from penetrating at the joints where the ends of the blocks come together, I set the end partitions (marked P, Fig. 1) a little back from the end of the block, thus leaving an opening R corresponding in purpose to the opening O and intermediate opening Y. When two blocks are joined together thus, a continuous joint is obviated and the object is secured. This is shown at N in Fig. 9. In the use of such hollow walls it is desirable to distribute the minimum amount of material in such a manner as to secure the greatest strength where it is most needed in the building, and as that part of the wall which supports the joists and floors is in need of more strength than other parts I use a course of blocks around the building especially adapted for this purpose. (Represented by Fig. 2.) By reference to the cross-section of this block, Fig. 3, on the line 3 3, it will be seen that the opening O does not extend entirely through the block, and thus is left a solid bottom, (marked B,) the object of which is to, first, give additional strength to resist lateral pressure of the wall, and, second, to make a firm and substantial seat for the joists which support the floors, &c. It will be seen that this block, Fig. 2, is provided with side openings (marked

G) extending to the central opening O, and these are receptacles to receive and hold the joists or bond-timber, (marked T in Figs. 3 and 9.) By forming the lower ends of these receptacles in the manner shown a shoulder is left on the inside of the opening O, as shown by the letter S in Figs. 3 and 4, and the object of this shoulder is to enter a corresponding notch cut into the joists or bond-timber, as shown by the letter S, Fig. 3, and is for the purpose of tying and binding the walls firmly together. By the use of this particular block three important results are attained—viz., first, the means by which the joists bind the walls together; second, greatly increased strength under the joists which have to support the floors, &c., and, third, a long and perfect seat on which the joists rest. In order to strengthen the building still more, a block especially adapted to form the corner is shown by Fig. 8. Two desirable advantages are gained by the use of this block, which has an inner angle, as shown at A in Figs. 8 and 9—first, a corner of the building is secured without a single joint, which is a most desirable feature; but the second advantage is the means by which a perfect bond of the different courses of the blocks is preserved, as shown in Fig. 5. If the blocks of the side walls came through at the corners, as heretofore, the joints thus occasioned would not come in the center of the long blocks, thus destroying the perfect bond and harmony of the ashlar; but with a block containing an inner angle, as shown by the letter A in Figs. 8 and 9, the bond and harmony, perfectly retained and combined with the increased strength, are valuable. As a further means to secure the greatest strength with a minimum amount of material I provide a raised projection or longitudinal bead, molded lengthwise on the stone, as shown at D in nearly all the figures. By the use of this bead the bearings are always in the center of the stone, which is the strongest part, as shown more particularly at D, Fig. 3. It is also a gage by which to spread the thickness of the mortar as the blocks are laid in the wall, thus giving a true and even bearing and materially adding to the strength of the wall when the mortar is dry and hard.

In Fig. 6 is shown a section of blocks (marked X) of a different shape from and for a different purpose than any of the others. These sections of blocks are built into the walls wherever desired to secure the results and are for one or more of the following purposes: as a chimney for conducting smoke, as a pilaster for giving strength, and as a means for preventing vertical cracks in the walls. It will be understood that while heat is conducted when used as a chimney the change of temperature is liable to expand and contract the material of which the wall is composed, sometimes causing harmless, but unsightly, cracks to appear if the walls are long and unbroken, and to prevent this advantage is taken at this point

to form a "sliding joint," which will allow of expansion and contraction without pulling the blocks apart to cause the crack. It will be seen by reference to the letters E E, Fig. 6, that these joints are in the nature of a mortise and tenon, and while they allow for expansion and contraction will not produce an unsightly crack. It should be understood that these sections can be used for this purpose alone when no chimney or pilaster is required, in which case shorter sections of different designs on the outside can be arranged with the sliding joint, as shown at E E, Fig. 6. It will be observed that in nearly all these blocks there are two large openings (marked O) and an intermediate opening (marked Y) which corresponds in size and shape to an opening formed by uniting the ends of two other blocks having the opening marked R. By this means the builder is enabled to keep these openings in alinement one above the other, thus giving more perfect ventilation and also allowing the air to pass that course of blocks which have the bottom to support the joist, as shown at Y in Fig. 4.

When absolutely fireproof buildings are to be constructed by this method, it should be understood that the wooden joists can be dispensed with and in their place iron or steel beams be used; but the general construction of tying the walls and supporting these beams is the same, also in regard to the door and window frames, of which both wood and stone or metal can be used, as desired, the construction of both wood and stone being shown by Fig. 10.

In Fig. 9 is shown a section of frame made of artificial stone or concrete C C, resting on the door-sill. In this way the frame can be put up in sections as the wall is laid or in one piece, as desired; but in either case the projecting lug C² is made to enter the opening of the block marked R, thus making a perfectly water-tight joint at this point all around the frame. The rabbet or offset on the inside of this frame (shown by the letter F) is for the same purpose when a metal sash is used.

When from any cause it is desired to use a wooden frame, I construct them, as shown by Fig. 10, with the front casing H in one piece and forming a part of the projecting lug C², Fig. 9. By this means it will be seen that as this part sets back into the opening R (represented at C, Fig. 9) a crack or joint is obviated. The shown in Fig. 10 (marked K) is for cords and window-weights.

In Fig. 9 the different blocks are assembled in the wall to form a building possessing the merits which I claim in the foregoing specification. Beginning with the lower course of blocks at the right in Fig. 9, I use the blocks shown by Fig. 1, joining the ends, as shown at N. A continuous joint is obviated, and the shape and size of the opening thus made are the same as the intermediate opening Y. When the corner is reached, the block repre-

5 sented by Fig. 8 is placed in position, with the short side (which is a half-block) to the left, and to this is joined another whole block, as shown by Fig. 1, and to this is attached the frame, as before described. Returning to the corner, I reverse the corner-block and put the short side to the right, thus making a perfect bond and all openings in alinement one above the other. When the desired height is attained for the floors or bond-timbers, the block shown by Fig. 2 is placed in position around the building, the joists are notched and fitted and placed in the gains G, and the next course of blocks, Fig. 1, is laid over the joists, and so on to the roof.

15 While only right angles are above referred to, it will be understood that any other angle can be made in the same way and for the same purpose.

20 In Fig. 11 is shown a modified form in which these walls can be constructed combined with brick or similar material. By dividing the blocks represented by Fig. 1 on the line 4 4, Fig. 2, I have one side of the block W provided with the cross-partitions P P. By these cross-partitions the other side, made of brick or other material L, may be united to the concrete side W, thus preserving the opening O substantially as though both sides were made of concrete and either side may be the outside of the building.

35 In Fig. 6 (letters) J J is shown an iron band which is sometimes embedded in the concrete block when the same is molded and is for the purpose of strengthening and preventing the blocks from cracking when extra or unusual weight or stress is brought to bear upon them. This can also be put in any of the other blocks and is designed to be a continuous band, strengthening the ends as well as the sides. In Fig. 12, which is a cross-section of Fig. 6 on the line 12 12, this band is at the top of the block, but may be in the middle or where desired.

45 Having thus described my invention, what

I claim as new, and desire to secure by Letters Patent, is—

1. The within-described building-wall constructed of hollow concrete blocks, and containing the corner-block with the inner angle as shown at A in Figs. 8 and 9, and opening O for the purpose as shown and described. 50

2. The within-described building-wall constructed of hollow concrete blocks, containing the block Fig. 2, provided with the bottom B substantially as specified. 55

3. The within-described building-wall constructed of hollow concrete blocks, one or more sections connected by an exterior lap projecting from one of the adjacent pairs as shown at E for the purpose of hiding exteriorly the crack caused by expansion and contraction of the material employed, substantially as and for the purpose set forth. 60

4. The above-described building-wall constructed of hollow concrete blocks shown by Figs. 1, 2, 6, and 8, all combined substantially as and for the purpose herein shown and described. 65

5. The within-described building-wall constructed of hollow concrete blocks, in combination with a wooden frame containing the cavity K, and the casing H forming a part of the projecting lug C², as shown in Fig. 9, all combined substantially as set forth. 70

6. The within-described hollow building-wall consisting of one concrete side W (Fig. 11) provided with the cross-partitions P P by which is connected the opposite side L made of brick or other material, so as to leave an air-space O, substantially as set forth. 75

7. The within-described building-wall constructed of hollow concrete blocks, said blocks containing a band of metal embedded therein as shown by the letters J J Fig. 6, as set forth. 80

HARMON S. PALMER.

Witnesses:

DUNCAN M. MOORE,
LOUIS B. DORR.