

A PROGRAM OF IBHS

FORTIFIED

HOME

NEW CONSTRUCTION

TM

HURRICANE

TECHNICAL SUMMARY



2012

FORTIFIED HOME™
Technical Requirements
New Home



INTRODUCTION

The Insurance Institute for Business & Home Safety's FORTIFIED Home™: Hurricane Standard helps homeowners in coastal areas strengthen their houses against these powerful storms. Incorporating FORTIFIED features when repairing, rebuilding or renovating your single-family home will transform your house into a more a resilient and durable property.

The FORTIFIED features focus first on strengthening and protecting the roof because it is the home's first line of defense against severe weather events. This can include things like sealing the roof deck to prevent wind-driven rain from getting inside, using roof covering that is rated for the wind speeds in your area to reduce the chances it will lift up or blow off during high winds, and using soffit vents that resist water intrusion. Protecting the openings in the house, such as doors and windows, also is important. One of the most effective FORTIFIED features you can incorporate when rebuilding is to think of your house as a system and create a continuous load path by tying the structural elements of the building together. Tying the roof to the walls, the walls to the floor and the floor to the foundation will significantly strengthen your home when Mother Nature strikes.

For more detailed information about how to make your home stronger, safer and more hurricane-resistant, please visit www.DisasterSafety.org/FORTIFIED. Also, follow us on Twitter at @DisasterSafety and on Facebook at www.facebook.com/buildfortified.



Hazard: Hurricane

Locations where the design wind speed exceeds 90 mph as determined in ASCE7-05

Construction Type: New residential, single-family detached homes

FORTIFIED Home™: Hurricane Bronze Requirements:

- Roof deck must be a minimum of 7/16 in. OSB or Plywood.
- Roof deck must be attached with 8d ring shank nails, spaced nominally at 6 in. o.c. along the edges and in the field; unless engineering analysis or local code requires more fasteners at the corners.
- Roof deck must be sealed with a qualified system. There are three qualified methods for sealing from the top side (described below).
 - Cover the entire roof deck with a full layer of self-adhering polymer modified bitumen membrane meeting ASTM D1970 requirements. It is recommended that the membrane is covered with 15# felt before shingles are applied to provide bond break, and to keep shingles from fusing with the self-adhering membrane.
 - Apply a self-adhering polymer modified bitumen flashing tape, which is at least 4 in. wide, directly to the roof deck to seal the horizontal and vertical joints. Next, apply a code-compliant 30-pound ASTM D226, Type II underlayment over the self-adhering tape. This underlayment must be attached using annular ring or deformed shank roofing fasteners with minimum 1 in. diameter caps at 6 in. o.c. spacing along all laps and at 12 in. o.c. in the field, or a more stringent fastener schedule, if required by the manufacturer for high-wind installations. Horizontal laps shall be a minimum of 2 in. and end laps shall be a minimum of 6 in. Nails with plastic or metal caps are allowed in areas where the design wind speed is less than 140 mph. Metal caps are required for areas where the design wind speed is greater than or equal to 140 mph.

FORTIFIED HOME™
 Technical Requirements
 New Home



- Apply reinforced synthetic roof underlayment that has an ICC approval as an alternate to ASTM D226 Type II felt paper. The synthetic underlayment must have minimum tear strength of 20 lbs. per ASTM D1970 or ASTM D4533. This underlayment must be attached using annular ring or deformed shank roofing fasteners with minimum 1 in. diameter caps at 6 in. o.c. spacing along all laps and at 12 in. o.c. in the field, or a more stringent fastener schedule, if required by the manufacturer for high-wind installations. Metal caps are required for areas where the design wind speed is greater than or equal to 140 mph.
- A drip edge must be installed (at eaves and rakes) with 3 in. laps. Drip shall extend ½ in. below sheathing and extend back on the roof a minimum of 2 in. Drip edge at eaves shall be permitted to be installed either over or under the underlayment. Drip edge at gable rake shall be installed over the underlayment. The drip edge shall be mechanically fastened to the roof deck at a maximum of 4 in. o.c.
- Shingle roof covering must be high-wind rated (Class F or higher) based on design wind speed. See chart below:

ASCE 7-05 Wind Speed (V_{asd})	ASCE 7-10 Wind Speed (V_{ult})	Shingle Wind Testing Standard/Classification
100 MPH	129 MPH	ASTM D3161 (Class F) or ASTM D 7158 (Class G or H) ¹
110 MPH	142 MPH	ASTM D3161 (Class F) or ASTM D 7158 (Class G or H) ¹
120 MPH	155 MPH	ASTM D 7158 (Class G or H) ¹
130 MPH	168 MPH	ASTM D 7158 (Class H) ¹
140 MPH	180 MPH	
150 MPH	H	

¹ **Note:** When used in Exposure D locations, shingles must pass both ASTM D3161 Class F **and** ASTM D7158 Class H testing standard.

FORTIFIED HOME™
Technical Requirements
New Home



- Concrete and clay tile systems and their attachment shall meet the requirements of the site design wind speed and exposure category.
- Metal panel roof systems and their attachment shall be installed in accordance with the manufacturer's installation instructions and shall provide uplift resistance equal to or greater than the design uplift pressure for the roof based on the site design wind speed and exposure category.
- Gable walls must have minimum of 7/16 in. structural sheathing (OSB or Plywood).
- Gable overhangs must not be vented.
- Gable wall vents must be protected against water intrusion.
- Gable overhangs framed using outlooker framing must have adequate connection at gable wall and at roof framing members. Connection can be determined by structural engineer or by using IBHS prescriptive connection detail (see page 19 of the FORTIFIED Home™: Hurricane Standards, http://disastersafety.org/wp-content/uploads/fortified-hurricane-standards_IBHS.pdf).
- Box type soffit overhangs (eave) and gable overhangs with a depth greater than 12 in. (measured from the back of fascia to exterior wall surface) and covered with aluminum or vinyl material, must have a center brace installed mid-span.
- Roof-mounted vents, including but not limited to ridge vents, off-ridge vents and turbines, must meet Florida Building Code TAS 100(A).

FORTIFIED HOME™
Technical Requirements
New Home



Hurricane Silver Requirements:

- All Bronze requirements must be satisfied.
- Gable end walls on gables greater than 48 in. in height must be braced.
- Porches and carports must have adequate connections for uplift pressures based on site design wind speed and exposure category. Connections must be provided from the roof framing to the beam/wall, from beam to column and column to structure below.
- Garage doors must be pressure rated for pressures associated with site design wind speed and exposure category.
 - Exception: if garage door has glazing, door must be pressure rated and impact rated, or pressure rated and protected with a qualified impact-resistant system.
- All window, exterior door and skylight openings must be protected with qualified opening protection systems.
 - Qualified opening protection systems must have passed an ASTM E 1996 and E 1886 impact test for large missile "D".

FORTIFIED HOME™
Technical Requirements
New Home



Hurricane Gold Requirements:

- All Bronze and Silver requirements must be satisfied.
- Chimneys must be adequately connected to the roof structure to resist loads based on site design wind speed and exposure category.
- Windows, skylights and glass doors: Windows and glass doors must be rated for the design pressures appropriate for the exposure category, wind speed, window size, and window location on the building. See Appendix C of the FORTIFIED Home™: Hurricane Standards, http://disastersafety.org/wp-content/uploads/fortified-hurricane-standards_IBHS.pdf.
- A continuous load path must be designed and installed providing connection from roof to wall, wall to floor and floor to foundation.
- Walls must have minimum of 7/16 in. structural sheathing (OSB or Plywood).

NOTICE: ALL OF THE ABOVE MUST BE DOCUMENTED PRIOR TO BEING CONCEALED BY FINISHED MATERIALS. TAKE PHOTOGRAPHS OF THE IMPROVEMENTS WHILE THE HOME IS UNDER CONSTRUCTION. A COMPLETE PHOTO FILE SHOULD BE PRESENTED TO THE FORTIFIED EVALUATOR WORKING ON THE PROJECT.

In addition, certification letters from a structural engineer will be required to satisfy the documentation requirements for outlooker framing, gable framing and bracing, porch/carport connections, chimney connections and load path design. Copies of these letters can be obtained from IBHS or your FORTIFIED Evaluator.



Sealed Roof Deck

Bulletin No. 2015-01

First Release:

March 19, 2015

Prepared by:

Fred Malik, Vice President,
FORTIFIED Programs

Applicable Standards:

FORTIFIED Home™–Hurricane
FORTIFIED Home™–High Wind
FORTIFIED Home™–High Wind & Hail
FORTIFIED for Safer Living™

Applicable Designation Level:



Installation of 2 Layers of #30 Felt as a Qualified Sealed Roof Deck System for Asphalt Shingle or Metal Roofing

Abstract

The installation of 2 layers of #30 roofing felt has been tested, evaluated and approved by IBHS as a qualified sealed roof deck system for asphalt shingle or metal roofing.

Requirements

- Two (2) layers of ASTM D226 Type II (#30) or ASTM D4869 Type III or Type IV (#30) underlayment shall be installed in a shingle fashion, lapped 19 in. on horizontal seams (36-in. roll), and 6 in. on vertical seams.
 - **NOTE:** Be sure to check product labeling carefully. Not all products labeled ASTM D4869 are Type III or Type IV. Look for ASTM D4869 felt that is labeled Type III or Type IV. ASTM D4869 Type I or Type II will **NOT** be accepted.
- Installation of first course of felt to be installed as described below and shown in Figure 1.
 - Cut 17 in. off one side of the roll and install the remaining 19-in.-wide strip of underlayment* along the eave. Safely tack in place. Carefully install a 36-in.-wide roll of underlayment* over the 19-in.-wide course of underlayment along the eave. Follow the same procedure for each, overlapping the sheets 19 in. (leaving a 17-in. exposure). Fasten with one row in the field of the sheet at 12 in. o.c. and one row at the overlaps fastened 6 in. o.c.
- Fasten underlayment at approximately 6 in. o.c. along the laps and at approximately 12 in. o.c. in the field of the sheet between the side laps.
 - For design wind speeds less than 140 mph (ASCE 7-05): secure underlayment using annular ring or deformed shank nails with 1-in.-diameter caps (button cap nails).

*Must use ASTM D226 Type II (#30) or ASTM D4869 Type III or Type IV (#30) underlayment.

Sealed Roof Deck

Bulletin No. 2015-01

First Release:

March 19, 2015

Prepared by:

Fred Malik, Vice President,
FORTIFIED Programs

Applicable Standards:

- FORTIFIED Home™–Hurricane
- FORTIFIED Home™–High Wind
- FORTIFIED Home™–High Wind & Hail
- FORTIFIED for Safer Living™

Applicable Designation Level:



- For design wind speeds 140 mph or greater (ASCE 7-05): secure underlayment using annular ring or deformed shank nails with thin metal disks (“tincaps”).

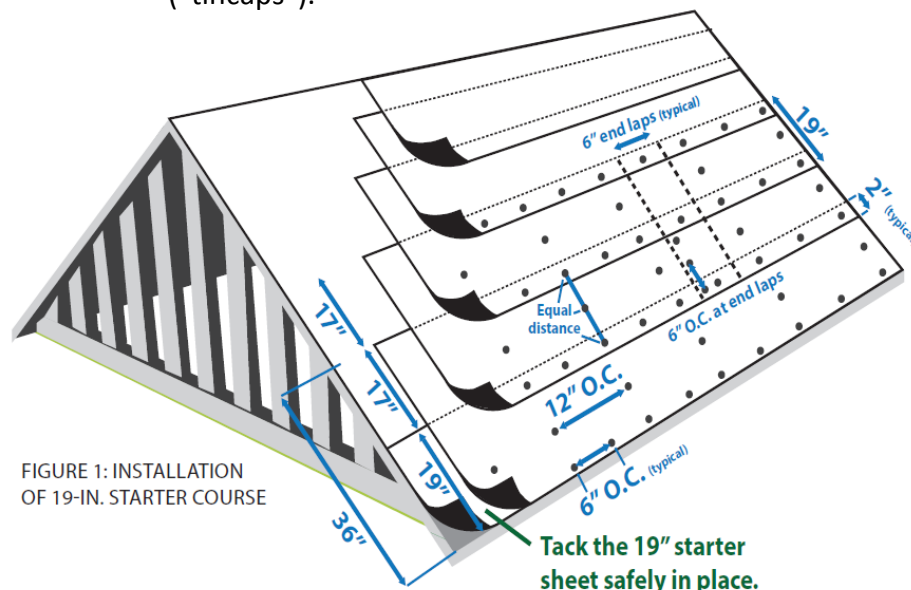

FIGURE 1: INSTALLATION OF 19-IN. STARTER COURSE

Compliance Verification Requirements

This method of sealing the roof deck is to be documented and verified by a certified FORTIFIED evaluator. Acceptable documentation includes but is not limited to: pictures of laps and fasteners at 4 different locations of the roof; a completed Roof Compliance Form (RCF-1); certification by the installer; bills of lading; invoices; and product packaging.

Completing Evaluation Form (For FORTIFIED Evaluators Only)

On the evaluation form, in the “Sealed Roof Deck” section, for question SRD System Type, select “Other” (see Figure 2 below). It will be necessary to provide documentation as described above.

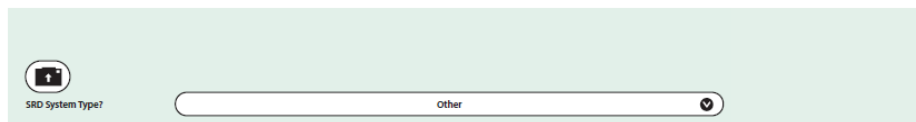

Figure 2. Evaluation Form; Section—Sealed Roof Deck; Question—SRD System Type?



Sealed Roof Deck

Material Options for Taping Roof Deck Seams

Bulletin No. 2015-02

First Release:

July 31, 2015

Prepared by:

Fred Malik, Vice President,
FORTIFIED Programs

Applicable Standards:

- FORTIFIED Home™–Hurricane
- FORTIFIED Home™–High Wind
- FORTIFIED Home™–High Wind & Hail
- FORTIFIED for Safer Living™

Applicable Designation Level:



Abstract

The material options for taping the seams of the roof deck have been expanded to include AAMA 711-13, Level 3 (for exposure up to 80°C/176°F).

Requirements

There are two material options for taping the seams on the roof deck.

Option 1

Apply an ASTM 1970 compliant self-adhering polymer-modified bitumen flashing tape, at least 4-in. wide, directly to the roof deck to seal the horizontal and vertical joints in the roof deck.

Option 2

Apply an AAMA 711-13, Level 3 (for exposure up to 80°C/176°F) compliant self-adhering flexible flashing tape, at least 3¼-in. wide, directly to the roof deck to seal the horizontal and vertical joints in the roof deck.

Any flashing tape used to achieve a sealed roof deck must be fully adhered without voids (e.g., wrinkles) in order to be accepted. In some instances, the ability of self-adhered flashing tapes to adhere to Oriented Strand Board (OSB) sheathing may be compromised by the level of surface texture or the wax used to improve the water resistance of the OSB panel. In applications where flashing tape adhesion to OSB is marginal, apply a manufacturer-specified compatible primer to the OSB panels where the tape will be applied to ensure the proper attachment of the self-adhering tape to the sheathing. Do not nail or staple the tape to the roof sheathing. Refer to the manufacturer’s recommendations for installation and primer requirements (if applicable). Next, apply a code-compliant #30 ASTM D226 Type II or ASTM D4869 Type IV underlayment over the self-adhering tape. This underlayment must be attached using annular ring or

Sealed Roof Deck

Bulletin No. 2015-02

First Release:

July 31, 2015

Prepared by:

Fred Malik, Vice President,
FORTIFIED Programs

Applicable Standards:

- FORTIFIED Home™–Hurricane
- FORTIFIED Home™–High Wind
- FORTIFIED Home™–High Wind & Hail
- FORTIFIED for Safer Living™

Applicable Designation Level:



Note: Although 4 photographs is the minimum number of pictures required, the goal is to achieve a 360° view of the house and FORTIFIED upgrades. Most photographs will be taken from the ground and site conditions may dictate that more than the minimum be provided.

deformed shank roofing fasteners with minimum 1-in.-diameter caps (button cap nails) at 6 in. o.c. spacing along all laps and at 12 in. o.c. in the field or a more stringent fastener schedule if required by the manufacturer for high-wind and prolonged exposure installations. Horizontal laps must be a minimum of 2 in. and end laps must be a minimum of 6 in.

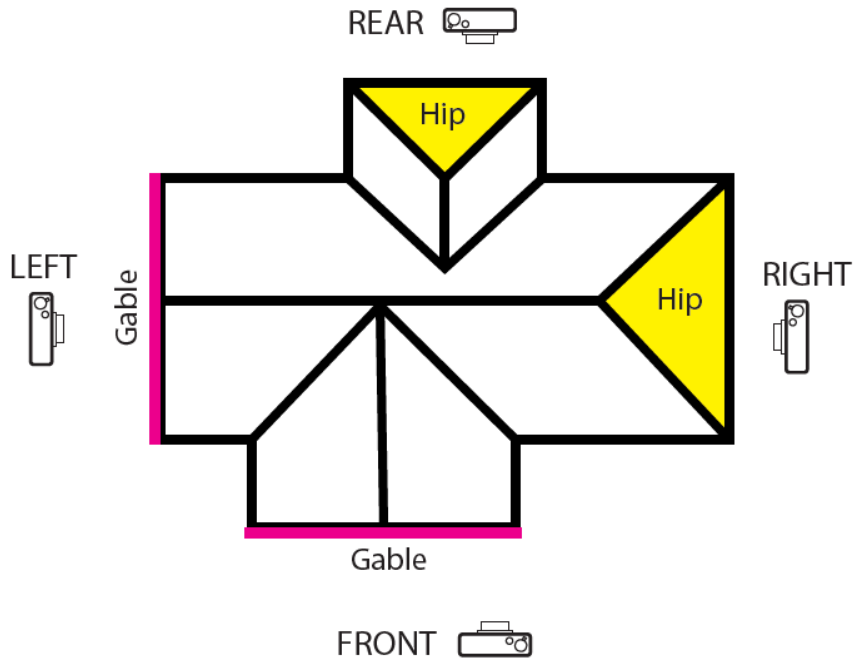

Figure 0-1. Minimum photograph requirement and locations (Front, Rear, Left and Right).

Compliance Verification Requirements

This method of sealing the roof deck is to be documented and verified by a certified FORTIFIED Evaluator. Acceptable documentation includes, but is not necessarily limited to:

Pictures of Tape Installed

Count: Minimum = 4

- Must show 4 different sections of the roof (Front, Rear, Left and Right). See Fig. 0-1.
- Must clearly show tape fully adhered to the deck without wrinkles or voids. See Fig. 0-2.
- Must show at least one full sheet of roof decking (with all 4 seams taped) per photo.
- Must be in focus.

Sealed Roof Deck

Bulletin No. 2015-02

First Release:

July 31, 2015

Prepared by:

Fred Malik, Vice President,
FORTIFIED Programs

Applicable Standards:

FORTIFIED Home™–Hurricane
FORTIFIED Home™–High Wind
FORTIFIED Home™–High Wind & Hail
FORTIFIED for Safer Living™

Applicable Designation Level:



- Must have the following clearly visible: date, address or FORTIFIED ID, location (e.g., Front, Rear, Left and Right). See Fig. 0-3.

Pictures of Felt Installed

Count: Minimum = 4

- Must show 4 different sections of the roof (Front, Rear, Left and Right).
- Must clearly show laps and fasteners.
- Must have the following clearly visible: date, address or FORTIFIED ID, location (e.g., Front, Rear, Left and Right).

Other Documentation Required

- Completed Roof Compliance Form (RCF-1) identifying tape manufacturer, specification requirement (ASTM 1970 or AAMA 711-13, Level 3) and type of compatible primer, if used.

OR

- Invoices and product packaging identifying tape product name, manufacturer, specification requirement (ASTM 1970 or AAMA 711-13, Level 3) and type of compatible primer, if used.



Figure 0-2. Applying qualified tape to roof deck seams using flat blade to eliminate voids and wrinkles.

Sealed Roof Deck

Bulletin No. 2015-02

First Release:

July 31, 2015

Prepared by:

Fred Malik, Vice President,
FORTIFIED Programs

Applicable Standards:

- FORTIFIED Home™–Hurricane
- FORTIFIED Home™–High Wind
- FORTIFIED Home™–High Wind & Hail
- FORTIFIED for Safer Living™

Applicable Designation Level:

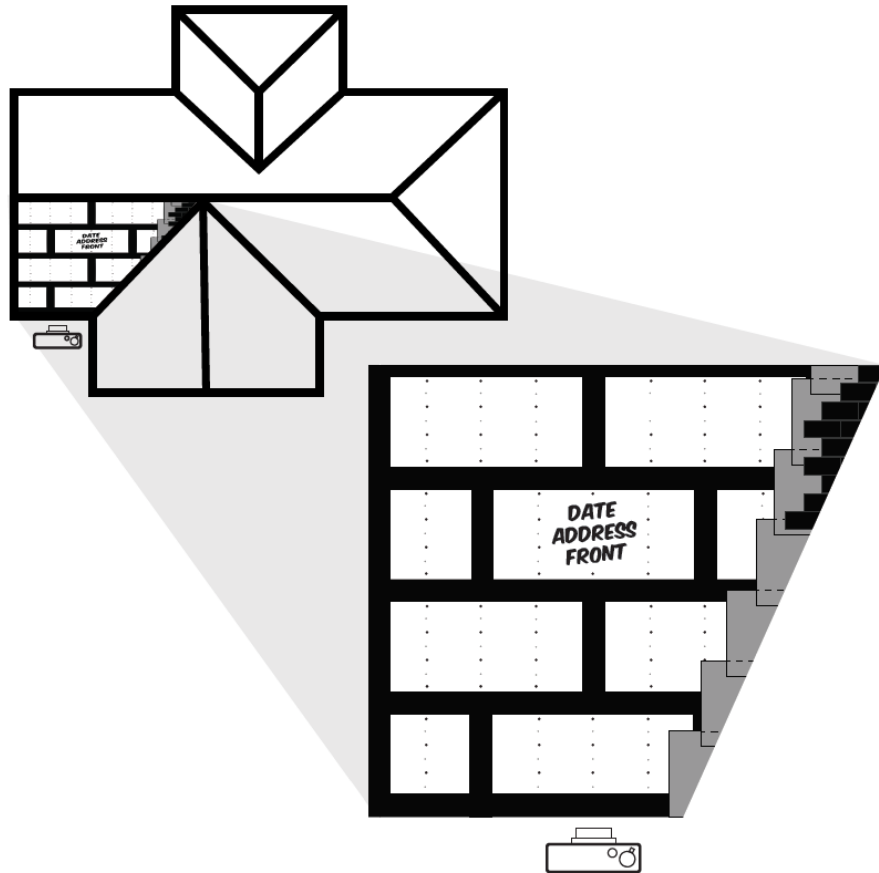

Figure 0-3. Labeling of roof deck to identify project and photo location.

Completing Evaluation Form

When completing the Sealed Roof Deck section of a FORTIFIED Home Evaluation form, select SRD System Type as shown in Fig. 0-4. Add photos and other documentation by clicking on the camera icon.

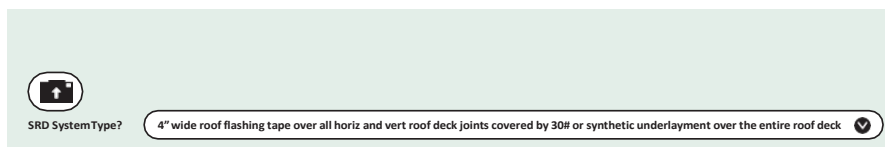

Figure 0-4. Selection for SRD system type.

Bulletin No. 2015-04

First Release:

October 13, 2015

Prepared by:

Fred Malik, Vice President,
FORTIFIED Programs

Applicable Standards:

FORTIFIED Home™–Hurricane
 FORTIFIED Home™–High Wind
 FORTIFIED Home™–High Wind & Hail
 FORTIFIED for Safer Living®

Applicable Designation Level:



Using 2-Part Closed-Cell Foam Adhesive

Abstract

Strengthening the attachment of roof sheathing and installation of a sealed roof deck system can be achieved simultaneously by applying an ASTM or TAS tested two-part, spray polyurethane foam adhesive to the underside of the roof deck as shown in Figure 1.

This system can satisfy two FORTIFIED Home™–Bronze requirements:

1. Sealing the roof deck.
2. Supplemental deck attachment, when the roof deck is fastened with staples, 6d common nails or 8d common nails at 12 in. on center in the field.



Figure 1. Closed-cell polyurethane foam adhesive applied to the underside of the roof sheathing at the joints between the sheathing panels and along all intersections between roof sheathing and all roof framing members.



Sealed Roof Deck Supplemental Deck Attachment

Bulletin No. 2015-04

First Release:

October 13, 2015

Prepared by:

Fred Malik, Vice President,
FORTIFIED Programs

Applicable Standards:

FORTIFIED Home™–Hurricane
FORTIFIED Home™–High Wind
FORTIFIED Home™–High Wind & Hail
FORTIFIED for Safer Living®

Applicable Designation Level:



Requirements

A 2-part closed-cell foam polyurethane adhesive can be used on new or existing homes. This system is most commonly used on existing homes where the roof cover is deemed to be in good condition and NOT in need of replacement. When the roof cover is not being replaced, other systems that are installed from the topside cannot be used. Spray foam allows for improvements to be made from within the attic. This system can be used to satisfy two FORTIFIED Home™–Bronze requirements:

1. Sealing the roof deck.
2. Supplemental deck attachment, when the roof deck is fastened with staples, 6d common nails or 8d common nails at 12 in. on center in the field.

The minimum requirements for spray adhesives are:

- Product must be tested and evaluated in accordance with either ASTM E330, Standard Test Method for Structural Performance of Exterior Windows, Doors, Skylights and Curtain Walls by Uniform Static Air Pressure Difference (applied to roof sheathing), or TAS 202-94, Criteria for Testing Impact and Non- Impact Resistant Building Envelope Components Using Uniform Static Air Pressure. The minimum allowable Design Uplift Pressure must be greater than or equal to those listed below.
 - FORTIFIED Home™–Hurricane: at least 110 psf (proof test of at least 165 psf)
 - FORTIFIED Home™–High Wind: at least 80 psf (proof test of at least 120 psf)
 - FORTIFIED Home™–High Wind & Hail: at least 80 psf (proof test of at least 120 psf)
- Two-component spray polyurethane foam system with a minimum core density of 1.5–3.0 pcf in accordance with ASTM D1622, Standard Test Method for Apparent Density of Rigid Cellular Plastics.
- Spray polyurethane foam adhesive system must be installed by a properly trained and qualified applicator in accordance with the manufacturer’s maintenance and installation guidelines.



Sealed Roof Deck Supplemental Deck Attachment

Bulletin No. 2015-04

First Release:

October 13, 2015

Prepared by:

Fred Malik, Vice President,
FORTIFIED Programs

Applicable Standards:

FORTIFIED Home™–Hurricane
FORTIFIED Home™–High Wind
FORTIFIED Home™–High Wind & Hail
FORTIFIED for Safer Living®

Applicable Designation Level:



Note: In order for this method to be accepted for sealing the roof deck and for adding supplemental roof deck attachment, access to the entire underside of the roof deck within the attic must be available. If the slope of the roof is low, such that eaves are inaccessible, or any portion of the underside of the deck is obstructed by equipment or ductwork, or is otherwise inaccessible, it will be necessary to use an alternative qualified method to seal the portion of the deck that is unreachable by the spray foam installer.

To provide enhanced roof sheathing attachment and to seal the roof deck, apply a 1.5- to 3-in. fillet of 2-part spray-applied polyurethane foam adhesive to:

- All joints between sheathing
- All intersections between roof sheathing and roof framing members
- All valleys

Use the minimum density and installation requirements prescribed by the manufacturer to meet a minimum Design Uplift Pressure on the sheathing of 80 psf or 110 psf; as appropriate to the applicable standard.

All installations must be in accordance with the manufacturer’s instructions.

Compliance Verification Requirements

It is not possible to determine the chemistry of a spray foam product by visual inspection. Therefore, it is necessary to collect documentation from the installing contractor identifying the manufacturer and product used for the improved roof sheathing attachment/sealed roof deck.

Documentation must be provided to the Certified FORTIFIED Home™ Evaluator and be included with the FORTIFIED Home evaluation checklist. Documentation must state the installation meets the manufacturer’s requirements for an allowable Design Uplift Pressures detailed below.

- FORTIFIED Home™–Hurricane: at least 110 psf (proof test of at least 165 psf)
- FORTIFIED Home™–High Wind: at least 80 psf (proof test of at least 120 psf)
- FORTIFIED Home™–High Wind & Hail: at least 80 psf (proof test of at least 120 psf)



Sealed Roof Deck Supplemental Deck Attachment

Bulletin No. 2015-04

First Release:

October 13, 2015

Prepared by:

Fred Malik, Vice President,
FORTIFIED Programs

Applicable Standards:

FORTIFIED Home™–Hurricane
FORTIFIED Home™–High Wind
FORTIFIED Home™–High Wind & Hail
FORTIFIED for Safer Living®

Applicable Designation Level:



Note: Although 4 photographs is the minimum number of pictures required, the goal is to achieve a complete view of the underside of the roof deck. Photographs must be taken from inside the attic and show product installed in accordance with the requirements listed above. Site conditions may dictate that more than the minimum be provided.

Minimum Documentation Required

- Letter from installing contractor, on company letterhead, that the material was applied by a trained installer and the installation meets the manufacturer’s requirements for an allowable Design Uplift Pressure specified for the appropriate standard.
- Documentation from Miami-Dade, FBC, TDI product approvals or ICC Evaluation Reports, if applicable (invoices and/or product labels identifying product name and manufacturer may be substituted in the absence of product test documents).
- A minimum of 4 photos of the material applied to the entire underside of the roof deck. Pictures must be taken at 4 different locations of the attic to show complete coverage.

Completing Evaluation Form

(For FORTIFIED Evaluator)

Entering Supplemental Deck Attachment

Section: Roof Deck

First, identify type of attic accessibility.

Attic accessibility

Next, indicate qualified supplemental documentation is installed. Select closed-cell foam adhesive and upload documentation.

Is qualified supplemental deck attachment installed? Yes

What type of supplemental deck attachment is installed?

Entering the SRD System Type

Section: Sealed Roof Deck

Select a closed-cell foam applied along all roof framing members and over all horizontal roof deck seams. Upload documentation.

SRD System Type?



Eligible Dwellings

FORTIFIED Home™ Dwelling Type Eligibility Requirements

Bulletin No. 2016-01

First Release:

March 4, 2016

Prepared by:

Remington Brown,
Senior Engineering Director

Applicable Standards:

- FORTIFIED Home™–Hurricane
- FORTIFIED Home™–High Wind
- FORTIFIED Home™–High Wind & Hail
- FORTIFIED for Safer Living®

Applicable Designation Level:



Abstract

The purpose of this document is to provide specific information about the type of residential building that is eligible for designation consideration in the FORTIFIED Home™ program.

Introduction

The goal of IBHS FORTIFIED Home™ program is to strengthen homes against specific natural hazards using system-based resilience upgrades and a comprehensive verification process. “Home” or “dwelling” encompasses a broad category of residential buildings. This technical bulletin defines the specific types of residential buildings that are eligible for consideration in the FORTIFIED Home™ program.

Eligibility

Qualifying Homes—Dwelling Type

1. Single-family detached homes
2. Two-family dwelling units (duplex)
3. (HUD) manufactured homes
4. Townhouses

Definitions and Conditions

1. **Single-family detached home**—a freestanding residential building occupied by one family. Limited to three stories above grade. This also includes detached single-family factory-built modular homes that are designed, built and sited to meet all local building codes.
2. **Two-family dwelling units (duplex)**—a freestanding residential building occupied by two families. Limited to three stories above grade. Note: The entire two-family building, which includes both dwelling units under consideration, must be evaluated under the appropriate FORTIFIED Home™ requirements. Individually evaluated



Eligible Dwellings

Bulletin No. 2016-01

First Release:

March 4, 2016

Prepared by:

Remington Brown,
Senior Engineering Director

Applicable Standards:

- FORTIFIED Home™–Hurricane
- FORTIFIED Home™–High Wind
- FORTIFIED Home™–High Wind & Hail
- FORTIFIED for Safer Living®

Applicable Designation Level:



units are NOT eligible for designation outside of the entire building being designated.

- (HUD) manufactured homes**—a single-family residential home manufactured to HUD’s Manufactured Home Construction and Safety Standards. Must be sited on a permanent foundation. HUD manufactured homes built before July 1994 are NOT eligible.
- Townhouse**—a single-family dwelling unit constructed in a group of three or more attached units in which *each unit extends from foundation to roof and has a yard or public way on not less than two sides*. Limited to three stories above grade. Mixed use (commercial and residential) buildings are NOT eligible. Note: The entire townhouse building, which includes all townhouse units under consideration, must be evaluated under the appropriate FORTIFIED Home™ requirements. Individually evaluated townhouse units are NOT eligible for designation outside of the entire building being designated. Example: A four-unit, two-story townhouse with all units attached is eligible for FORTIFIED only if the entire building, including each and every townhouse unit, is evaluated.

Completing Evaluation Forms

(For the FORTIFIED Evaluator)

Address Entry in Evaluation Application

When completing the FORTIFIED Home Evaluation Application for two-family dwelling units (duplex) or townhouses, list all dwelling unit addresses for the entire building under consideration on the Property Address lines. The example below lists four address numbers for a four-unit townhouse.



Eligible Dwellings

Bulletin No. 2016-01

First Release:

March 4, 2016

Prepared by:

Remington Brown,
Senior Engineering Director

Applicable Standards:

- FORTIFIED Home™–Hurricane
- FORTIFIED Home™–High Wind
- FORTIFIED Home™–High Wind & Hail
- FORTIFIED for Safer Living®

Applicable Designation Level:



FORTIFIED Home Evaluation Application

Choosing to have a FORTIFIED Home™ evaluation conducted is important to understanding where your home is vulnerable to severe weather. A FORTIFIED Home is more resistant to damage from high winds and wind-driven rain common in thunderstorms, tropical storms, hurricanes and hailstorms. With three levels of FORTIFIED designation available: Bronze, Silver and Gold, you can choose a level of protection best suited to your budget and resilience goals. Take the first step and complete the FORTIFIED application below. Fields marked with an (*) are required.

1. Applicant Information

*I am :

*Application Type :

4. Property Information

*Estimated year your home was built?

3. Property Address

*Address Line1 :

Address Line2 :

*City :

*State :

*ZIP / Postal Code :

*Country :

2. Property Owner's Name

*Title :

*First Name :

*Last Name :

*HomeOwner Email :

*Confirm HomeOwner Email :

3. Property Address

*Address Line1 :

Address Line2 :

*City :

*State :

*ZIP / Postal Code :

*Country :

*Which FORTIFIED Home program are you interested in?

*Which level of FORTIFIED designation are you interested in achieving?

Figure 1. Application indicating four addresses for a four-unit townhouse.

Dwelling Type Entry in Evaluator Checklist

Figure 2 shows dwelling type options available on the Evaluator Checklist. This drop-down menu can be found in the General/Site Information section.

FORTIFIED HOME™
Where building safety research leads to real-world solutions.

IBHS Home My Evaluations Reports New Application Library Alerts

Section Navigation Menu Section Help Save Save & Exit Validation Error(s) FEH***** General Site Information Evaluation In Progress

Dwelling Type (Dropdown menu open showing: Single-family detached, Duplex, Townhouse, Manufactured Home)

Exposure Category

Finished Elevation Photos

Year Built

How was year built determined?

Building Height (to the nearest foot)

Is structure supported by dry stack or unreinforced foundation?

Is documentation of current termite bond or inspection available?

Was termite bond or inspection issued/performed within past 12 months?

Wind Speed (ASCE 7-05)

Figure 2. FORTIFIED Home Evaluator Checklist indicating dwelling type options.



Eligible Dwellings

Designation Certificates

Designation certificates will be issued based on verification of the appropriate FORTIFIED requirements and will list a single address for single-family detached homes. Two-family homes (duplex) and townhouse designation certificates will be issued with all addresses for the building listed on the certificate. Figure 3 is an example of a designation certificate for a four-unit townhouse.

Bulletin No. 2016-01

First Release:

March 4, 2016

Prepared by:

Remington Brown,
Senior Engineering Director

Applicable Standards:

- FORTIFIED Home™–Hurricane
- FORTIFIED Home™–High Wind
- FORTIFIED Home™–High Wind & Hail
- FORTIFIED for Safer Living®

Applicable Designation Level:



Figure 3. Example certificate for a qualified, four-unit townhouse.



Shingle Installation at Roof Edge

Bulletin No. 2016-05

First Release:

November 3, 2016

Prepared by:

Fred Malik, Vice President,
FORTIFIED Programs

Mark Zehnal, Senior Roofing Specialist,
FORTIFIED Program Manager – Great
Plains

Applicable Standards:

- FORTIFIED Home™–High Wind
- FORTIFIED Home™–High Wind & Hail
- FORTIFIED Home™–Hurricane

Applicable Designation Level:



Asphalt Shingle Installation at Roof Edges, Intersections and Valleys

Abstract

This updated document is intended to provide additional guidance and options for asphalt shingle installations at roof edges, intersections and valleys. The verification and documentation requirement referenced in the original technical bulletin (Technical Bulletin 2016-05, released November 3, 2016) was effective December 5, 2016.

Introduction

Research conducted at the IBHS Research Center on a number of three-year-old roofs with various edge attachment details clearly demonstrated the need to ensure that shingles are properly installed and well adhered along the perimeter of a roof. While this directive has been included in standards and guidance since the beginning of the program, and also addressed in manufacturers’ high-wind guidance for asphalt shingle installation, it has not been specifically spotlighted in compliance forms or in evaluator training.

As a result, IBHS is issuing this updated technical bulletin to provide additional guidance with options that describe alternate methods to help ensure that asphalt shingles are well sealed and connected at roof edges, intersections and valleys. Please make sure you become familiar with the installation requirements outlined below and work with roofers to ensure proper installation instructions are followed. **Additionally, appropriate documentation described at the end of this bulletin continues to be required for all asphalt shingle roof installations.**



Shingle Installation at Roof Edge

Bulletin No. 2016-05

First Release:

November 3, 2016

Prepared by:

Fred Malik, Vice President,
FORTIFIED Programs

Mark Zehnal, Senior Roofing Specialist,
FORTIFIED Program Manager – Great
Plains

Applicable Standards:

- FORTIFIED Home™–High Wind
- FORTIFIED Home™–High Wind & Hail
- FORTIFIED Home™–Hurricane

Applicable Designation Level:



Sealed Roof Deck Installation Options

Taped Sheathing Seams

Tape Installation

Tape must be rolled to help ensure it is installed flat and adheres to the deck. If the tape doesn't stick well, the seams must be primed or a different product that does stick well must be used. Recent IBHS experience suggests that there may be fewer adhesion problems for installations on OSB decks with the high temperature-rated acrylic tape allowed by the program.

Underlayment Installation

Apply a code-compliant ASTM D226, Type II underlayment over the self-adhering tape (felt or synthetic is allowed). This underlayment shall be attached using annular ring or deformed shank roofing fasteners with minimum 1-in.-diameter caps at 6 in. o.c. spacing along all laps and two rows 12 in. o.c. in the field or a more stringent fastener schedule if required by the manufacturer for high-wind installations. Horizontal laps shall be a minimum of 2 in. and end laps shall be a minimum of 6 in. Nails with plastic or metal caps are allowed in areas where the design wind speed is less than 140 mph. Metal caps are required for areas where the design wind speed is greater than or equal to 140 mph.

ASTM D1970 Self-Adhered Membranes

ASTM D1970 Membrane Installation

Cover the entire roof with a full layer of self-adhering polymer-modified bitumen membrane meeting ASTM D1970 requirements.

Recommended Bond Break Installation

It is recommended that #15 felt be installed over the membrane to provide a bond break between the self-adhering membrane and the shingles in order to prevent the shingles from fusing with the self-adhering membrane. The bond break shall be held back 8 in. from the eave and rake edges to allow application of flashing cement along the edges to ensure proper sealing of shingles along the roof edges.



Shingle Installation at Roof Edge

Bulletin No. 2016-05

First Release:

November 3, 2016

Prepared by:

Fred Malik, Vice President,
FORTIFIED Programs

Mark Zehnal, Senior Roofing Specialist,
FORTIFIED Program Manager – Great
Plains

Applicable Standards:

FORTIFIED Home™–High Wind

FORTIFIED Home™–High Wind & Hail

FORTIFIED Home™–Hurricane

Applicable Designation Level:



Roof Edges, Intersections and Valleys

Drip Edge Installation Requirements

1. Provide code-compliant, minimum gauge metal drip edge at eaves and gables.
2. Overlap to be a minimum of 3 in. at joints.
3. Eave drip edges shall extend ½ in. below sheathing and extend back on the roof a minimum of 2 in.
4. The drip edge shall be mechanically fastened to the roof deck. Fasteners shall be fabricated from similar or compatible material. For FORTIFIED–Hurricane compliance, spacing shall be a maximum of 4 in. o.c. For FORTIFIED–High Wind and FORTIFIED–High Wind & Hail compliance, spacing shall be a maximum of 12 in. o.c. Mechanical fasteners shall be applied in an alternating (staggered) pattern along the length of the drip edge with adjacent fasteners placed near opposite edges of the leg/flange of drip edge on the roof.
5. Drip edge at eaves shall be installed over the underlayment (this is compatible with high-wind installations where flashing cement is used to seal the edges).

Installation of Starter Strips at Eaves (Drip Edge Installed Over Underlayment)

Manufacturer-approved starter strips at eaves shall be set in a minimum 8-in.-wide strip of compatible flashing cement.

Maximum thickness of flashing cement shall be ⅛ in. Fasten starter strips parallel to the eaves along a line above the eave line according to the manufacturer’s specifications. Position fasteners to ensure they will not be exposed under the cutouts in the first course. Starter strips and shingles must not extend more than ¼ in. beyond the drip edge.

Approved Option

Shingle manufacturer–approved ASTM D1970 fully adhered (peel-and-stick) starter strip with asphaltic adhesive strip at eave— installed so that starter strip adheres to and covers the drip edge top surface.



Shingle Installation at Roof Edge

Bulletin No. 2016-05

First Release:

November 3, 2016

Prepared by:

Fred Malik, Vice President,
FORTIFIED Programs

Mark Zehnal, Senior Roofing Specialist,
FORTIFIED Program Manager – Great
Plains

Applicable Standards:

- FORTIFIED Home™–High Wind
- FORTIFIED Home™–High Wind & Hail
- FORTIFIED Home™–Hurricane

Applicable Designation Level:



Installation of Shingles at Rakes (Drip Edge Installed Over Underlayment)

Install shingles at rakes set in a minimum 8-in.-wide strip of compatible flashing cement. Maximum thickness of flashing cement shall be 1/8 in. Fasten shingles at the rakes according to the manufacturer’s specifications.

Optional Installation of Starter Strips at Rakes (Drip Edge Installed Over Underlayment)

Manufacturer-approved starter strips at rakes shall be set in a minimum 8-in.-wide strip of compatible flashing cement. Maximum thickness of flashing cement shall be 1/8 in. Fasten starter strips parallel to the rakes according to the manufacturer’s specifications. Position fasteners to ensure they will not be exposed. Starter strips and shingles must not extend more than 1/4 in. beyond the drip edge.

Approved Option

Shingle manufacturer–approved ASTM D1970 fully adhered (peel-and-stick) starter strip with asphaltic adhesive strip at rake—installed so that starter strip adheres to and covers the drip edge top surface.

Attachment of Shingles at Intersections and Valley

Shingles installed at all intersections and both sides of open valleys shall be set in a minimum 8-in.-wide strip of flashing cement. Maximum thickness of flashing cement shall be 1/8 in. Cut side of closed valleys shall be set in a minimum 2-in.-wide, 1/8-in.-thick strip of flashing cement. Woven valleys to be according to the manufacturer’s specifications.



Shingle Installation at Roof Edge

Bulletin No. 2016-05

First Release:

November 3, 2016

Prepared by:

Fred Malik, Vice President,
FORTIFIED Programs

Mark Zehnal, Senior Roofing Specialist,
FORTIFIED Program Manager – Great
Plains

Applicable Standards:

FORTIFIED Home™–High Wind

FORTIFIED Home™–High Wind & Hail

FORTIFIED Home™–Hurricane

Applicable Designation Level:



Verification and Documentation

The contractor shall complete the revised compliance form and provide in-progress photos with identifiable traits or landmarks of the property showing the following:

1. Installation of tape or self-adhered membrane.
2. Fastening of underlayment.
3. Fastening of drip edge metal over underlayment.
4. Application of flashing cement or approved alternate means of attachment along roof edges, intersections and valleys.
5. Installation of approved starter strips at eaves.

The Evaluator shall verify that shingles along the edges of the roof do not overhang more than ¼ in. beyond the drip edge metal.



Roof Flashing

Bulletin No. 2017-01

First Release:

January 6, 2017

Prepared by:

Remington Brown,
Senior Engineering Director

Applicable Standards:

- FORTIFIED Home™–Hurricane
- FORTIFIED Home™–High Wind
- FORTIFIED Home™–High Wind & Hail
- FORTIFIED for Safer Living®

Applicable Designation Level:



Abstract

Roof flashing is an integral component of the roof system. It is used to seal roof systems where the system is interrupted or terminated and is **always** required when installing a new roof or re-roofing an existing home. Examples of roof flashing include: drip edge at the eave and rake, valley flashing, wall and chimney flashing, flashing at roof pitch changes, and flashing at all roof penetrations. This bulletin instructs installers that all flashing installed on a FORTIFIED roof must be in **new condition** and points to roof covering manufacturers for flashing installation instructions.

Requirements

When re-roofing an existing home or installing a roof on a new home, all installed flashing shall be new material. When re-roofing, all existing flashing material shall be removed and discarded. New flashing shall be properly installed in accordance with the roof manufacturer’s installation instructions and in compliance with all applicable building codes.

FORTIFIED has specific requirements for asphalt shingle drip edge flashing installation and attachment that may go beyond roof manufacturers’ flashing installation instruction and/or typical building code requirements. New drip edge metal must be installed at the eaves and the gable rakes.

Documentation Requirements

The installation of **new** roof flashing is to be verified by a certified FORTIFIED Evaluator through observation and photographs.



Gable End Overhang: Existing Homes Only

Bulletin No. 2017-02

First Release:

April 12, 2017

Prepared by:

Remington Brown,
Senior Engineering Director

Applicable Standards:

FORTIFIED Home™–Hurricane

Applicable Designation Level:



Retrofit for Ladder Framed Gable Overhang 12–18 in. Depth

Applicable Conditions

1. Existing homes only
2. Silver and Gold designation levels

Abstract

Older homes are often constructed with overhangs greater than 12 in. in depth. This bulletin provides prescriptive instructions, for the site condition limitations outlined below, on how to retrofit ladder framing on gable end overhangs to achieve a maximum depth of 18 in. from the face of the wall. Gable ends with ladder framed plywood/OSB overhangs greater than 18 in. seeking a Silver or Gold designation will require a site-specific engineered solution.

Site Condition Limitation

Exposure B

Mean Roof Height = 30 ft maximum

Wind Provision	ASCE 7-10
Wind Speed (mph)	160 (ultimate)

Requirements

FORTIFIED Home™ requirements have not changed. This prescriptive retrofit utilizes 2x framing members and 7/16-in. structural sheathing (plywood or OSB) at soffits to form a structural box which will enable an existing gable overhang to extend 18 in. to the outermost surface of the overhang without site-specific engineering.

Documentation Requirements

All components installed must be documented with photos and verified by a certified FORTIFIED Evaluator. Required photos include all installed framing and sheathing. Include photos of fasteners that clearly indicate sizes and spacing of the fasteners installed as well as at least one overview showing the continuous ledgers in place.

Bulletin No. 2017-02

First Release:

April 12, 2017

Prepared by:

Remington Brown,
Senior Engineering Director

Applicable Standards:

FORTIFIED Home™—Hurricane

Applicable Designation Level:



For Evaluators Only: Evaluation Form Input

Overhang retrofit documentation photos, material invoices, etc., should be uploaded into the SOFFIT section of the evaluation in FOCUS.

Retrofit Specifications

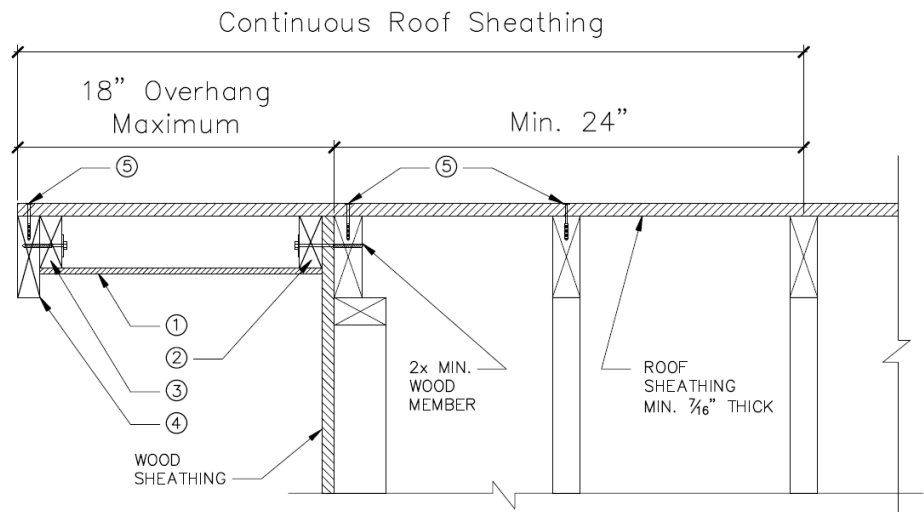

1. 7/16-in. structural sheathing (plywood or OSB) fastened to 2- x 4-in. ledgers with 8d nails at 3 in. o.c. at each end. Provide 2- x 4-in. blocking at all soffit panel joints.
2. 2- x 4-in. continuous ledger fastened to wall framing through exterior sheathing with #10 x 4-in.-long deck screw and a 1.5-in.-diameter washer at 6 in. o.c. and 3 in. from each end of the ledger.
3. 2- x 4-in. continuous ledger fastened to 2- x 6-in. fascia with #10 x 3-in.-long deck screw and a 1.5-in.-diameter washer at 8 in. o.c. and 3 in. from each end of the ledger.
4. 2x minimum fascia board.
5. Nail the roof deck to the fascia and first and second rafters with 8d ring shank nails at 4 in. o.c. (minimum 1½-in. penetration).



Bulletin No. 2017-03

First Release:

November 15, 2017

Prepared by:

Remington Brown
Senior Engineering Director

Applicable Standards:

FORTIFIED Home™–Hurricane
FORTIFIED for Safer Living™

Applicable Designation Level:

Low-Slope Roof Guidelines in Mobile and Baldwin Counties, Alabama

Abstract

This bulletin is intended to provide design guidance for residential roof systems installed over wood roof decks with a roof slope less than 2/12 (10 degrees). Low-slope roof systems must meet the required design pressures for the site and the locations on the building. Roofing manufacturers' tested uplift design pressures must have a factor of safety of 2:1; roof system design pressures listed in an ICC Evaluation Service Report, Florida Product Approval, or Miami-Dade Notice of Acceptance (NOA) have the 2:1 factor of safety already applied. These reports can be used to validate compliance with the project site-specific design pressure requirements. The report documents can be difficult to navigate; the roofing manufacturer technical services department is the best resource to help identify the correct system for the project.

Typical Residential Low-Slope Systems

Built-up roof (BUR) systems are composed of multiple layers of reinforcing membranes held together with hot bitumen, solvent-based adhesives, torch welding and self-adhered plies that create a finished membrane. The number of plies in a cross section is the number of membrane layers on a roof. The term "two-ply" denotes a two-layer membrane construction. When installed directly over the wood deck, the base sheet (also known as an anchor sheet) can either be mechanically fastened or attached with an adhesive foam or be a self-adhered product.

Modified bitumen roof systems are a form of BUR system that uses multiple layers of reinforcing membranes with a granulated or uncoated finish cap sheet that includes added modifiers to give plastic or rubber-like properties. Modified bitumen roof systems usually consist of two- or three-ply systems.



Roof System

Bulletin No. 2017-03

First Release:

November 15, 2017

Prepared by:

Remington Brown
Senior Engineering Director

Applicable Standards:

FORTIFIED Home™–Hurricane
FORTIFIED for Safer Living™

Applicable Designation Level:



Single-ply roofing membranes are flexible sheets of compounded synthetic materials that are generally mechanically attached or fully adhered to rigid insulation or a cover board. There are two categories of single-ply membranes: thermoplastic membranes such as TPO (thermoplastic olefin), PVC (polyvinyl chloride), and KEE (ketone ethylene ester), and thermoset membranes such as EPDM (ethylene propylene diene monomer).

Example for Mobile and Baldwin Counties

Low-slope roofs must be installed to meet design pressures for the site location *and* for the location on the roof. **Figure 1** (below) shows three roof “zones.” **Use 4 ft for dimension “a.”** The Corner Zone (Zone 3) is the roof zone that has the highest pressure (see **Table 1**) and is a 4-ft x 4-ft area in each of the four corners of the roof. The End Zone (Zone 2) is a 4-ft wide strip around the perimeter of the roof and the Interior Zone is the rest of the roof (anything not in Zones 2 or 3).

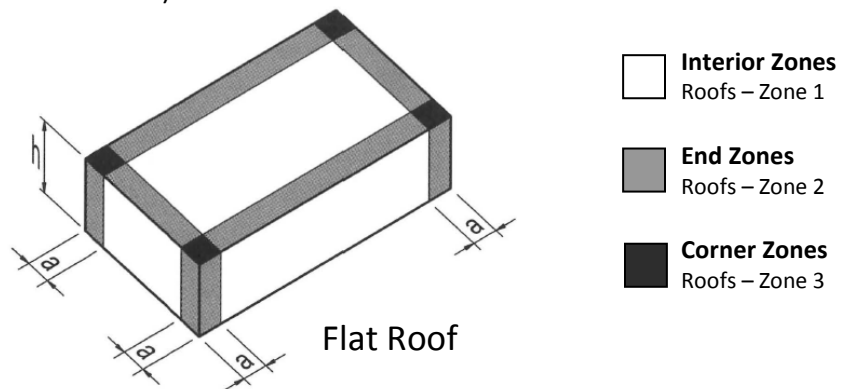

Figure 1. Flat Roof Zones

In Mobile and Baldwin counties, use **Table 1** to determine the roof uplift pressure you need for an approved roof system. Note that the ASCE 7-10 wind speed in Mobile and Baldwin counties does not exceed 160 mph in any location.

Table 1. Roof Uplift Pressures: 160 mph, 30 ft Max Roof Height

160 mph (ASCE 7-10)	Zone 1 (interior)	Zone 2 (end)	Zone 3 (corner)
Exposure B (residential neighborhood)	-28 psf	-47 psf	-70 psf
Exposure C (open area)	-39 psf	-66 psf	-98 psf
Exposure D (on water)	-47 psf	-78 psf	-116 psf



Roof System

Bulletin No. 2017-03

First Release:

November 15, 2017

Prepared by:

Remington Brown
Senior Engineering Director

Applicable Standards:

FORTIFIED Home™–Hurricane
FORTIFIED for Safer Living™

Applicable Designation Level:



Basic Procedure for Selecting a Roof Assembly

1. From **Table 1**, determine uplift pressure required for Zone 1 (field), Zone 2 (perimeter), and Zone 3 (corners).
2. Select a roofing system manufacturer and a method of application (self-adhered, mechanically fastened, hot mopped, single-ply, etc.).
3. There are many variables associated with flat roof systems; make sure you select a system that's appropriate for the roof deck. Most residential flat roof assemblies are applied over a wood deck without insulation; make sure the system you choose is compatible.
4. Select a roof assembly from the manufacturer that has an approval for a design pressure greater than or equal to the uplift pressures determined in step 1.
 - **NOTE:** It would be best to select a system rated for the corner (Zone 3) uplift pressures and use it for the entire roof. **For a home located in a residential neighborhood (Exposure B) in Mobile or Baldwin county, look for a roof assembly system that has an approval indicating a design uplift pressure of 70 psf. The ICC Evaluation Service Report, Florida Product Approval, and Miami-Dade Notice of Acceptance (NOA) already have the required 2:1 factor of safety incorporated in the listed design pressures.**

Installation

1. Re-fasten the wood deck as required by FORTIFIED or the roofing approval if it's more restrictive.
2. Apply base/anchor sheet, intermediate plies, cap sheet, and roof coating as required by the system approval. **Do not substitute materials; use the components and fasteners as listed in the system approval.**
3. Follow roof manufacturers' installation guidelines for edge details, parapet details, skylight curb details, pitch transitions, wall connections where roofs meet upper stories, and penetrations for vent stacks or hardware mounts.



Roof System

Bulletin No. 2017-03

First Release:

November 15, 2017

Prepared by:

Remington Brown
Senior Engineering Director

Applicable Standards:

FORTIFIED Home™–Hurricane
FORTIFIED for Safer Living™

Applicable Designation Level:



Documentation Requirements

The **Roofing Compliance Form** must indicate the manufacturer and system type of the roof assembly.

The product approval indicating the design pressure rating for the installed system must be provided to the Evaluator.

Photos indicating the attachment of the base/anchor sheet in compliance with the roofing system approval must be provided.



Bulletin No. 2017-04

First Release:

December 12, 2017

Prepared by:

Fred Malik, Vice President,
FORTIFIED Programs

Applicable Standards:

FORTIFIED Home™—Hurricane
FORTIFIED Home™—High Wind
FORTIFIED Home™—High Wind & Hail
FORTIFIED for Safer Living™

Applicable Designation Level:



Eligibility Requirements and Retrofit Requirements for Elevated-Floor (Not Slab-on-Grade) Houses

Applicable Conditions

1. Dry stack foundations: all house types
2. All elevated-floor home-to-foundation connections

Abstract

This technical bulletin is intended to clarify FORTIFIED Home™ requirements that relate to a home’s foundation and the need for the home to have a positive connection to the foundation in order to be eligible for a FORTIFIED Home designation. The criteria included are requirements for any and all FORTIFIED Home designations and are not limited to FORTIFIED Home Gold designations which address the continuous load path.

Requirements

Dry Stack Foundations

A dry stack foundation is defined as a foundation constructed of unrestrained stacked masonry or stone.

Eligibility: Homes that are supported by a dry stack foundation are ineligible for any level of FORTIFIED Home designation unless the home is retrofitted so that it is supported by and attached to a permanent foundation capable of resisting the design level wind uplift and lateral forces on the building.

All Foundations

To be eligible for designation or re-designation under the FORTIFIED Home program, homes with elevated floors (not slab-on-grade construction) must have adequate positive connections from the floor or wall structure to the supporting foundation, e.g. homes on piers or pilings must have a connection from the



Eligibility Requirements—Foundations

Bulletin No. 2017-04

First Release:

December 12, 2017

Prepared by:

Fred Malik, Vice President,
FORTIFIED Programs

Applicable Standards:

FORTIFIED Home™—Hurricane
FORTIFIED Home™—High Wind
FORTIFIED Home™—High Wind & Hail
FORTIFIED for Safer Living™

Applicable Designation Level:



piers/pilings to the perimeter beams of the house. All connectors must be free from damage, corrosion-resistant (if applicable) in accordance with Appendix D of the FORTIFIED Home—Hurricane standards, and installed per the connector manufacturer’s installation instructions.

HUD-Code Manufactured Home Foundations

Foundation must meet the design wind load requirements with no more than ¼-in. lateral deflection. Requirements specified in the U.S. Department of Housing and Urban Development (HUD) Permanent Foundation Guide for Manufactured Housing (HUD-4930.3G) dated September 1996 or later provide useful assistance in identifying suitable foundation options. Based on results of past inspections of home installations that were reported as permanent, the following requirements of the HUD Guide and FORTIFIED Home requirements are emphasized and are part of the Field Evaluation inspection.

1. Screw-in soil anchors are not considered a permanent anchorage and cannot be used as any part of the required permanent foundation unless their heads are restrained from lateral movement by embedment in a reinforced concrete footing or concrete slab.
2. All concrete masonry unit (CMU) bearing walls, piers and columns, as well as any units used as part of systems to resist uplift, overturning and lateral loads must be composed of reinforced concrete masonry with mortared bed and head joints. Cells with reinforcing must be fully grouted. Dry-stacking of CMU is not allowed.
3. All bearing walls, piers and columns must be installed on and connected to acceptable footings or a concrete slab. Footings and slabs must be protected from the effects of frost heave by extending below the frost line or by using a frost protected shallow foundation design.
4. Walls and piers used as part of the uplift, overturning or lateral load-resisting system must include adequately sized connections and elements capable of resisting tension or compression loads as appropriate. Straps or cables are acceptable, provided they are connected to the home or its chassis and transfer the design loads to the slab or footings supporting the walls, piers or columns. Use



Eligibility Requirements—Foundations

Bulletin No. 2017-04

First Release:

December 12, 2017

Prepared by:

Fred Malik, Vice President,
FORTIFIED Programs

Applicable Standards:

FORTIFIED Home™–Hurricane
FORTIFIED Home™–High Wind
FORTIFIED Home™–High Wind & Hail
FORTIFIED for Safer Living™

Applicable Designation Level:



of frictional resistance between the home or its chassis and the tops of the walls, piers or columns or between the bottom of the walls, piers or columns and the footings to resist lateral loads is not allowed.

Eligibility: Manufactured homes must be installed on a foundation designed and installed in accordance with the criteria outlined above. A certification attesting to compliance with the design requirements of the HUD Permanent Foundations Guide for Manufactured Housing (HUD-4930.3G) dated September 1996 or later, and the requirements outlined above must be provided by a licensed professional engineer or registered architect. A copy of the certification and foundation design must be provided before or during the Field Evaluation at the time of the house setting for reference by the inspector and submission to IBHS.

Documentation Requirements

A minimum of four (4) photographs of a home’s foundation is required. The photographs must be taken from four different locations around the perimeter of the home.

Photographs of connectors are required. If any damaged or corroded connectors are present, photographs of the damaged connector(s) need to be provided in the “General/Site Information” section of the evaluation form regardless of designation level being sought. Photographs can be added to the **Finished Elevation Photos** portion of the form.

For Evaluators Only: Evaluation Form Input

Photographs of the foundation and connectors from perimeter beam to foundation need to be uploaded in the “General/Site Information” section of the evaluation form regardless of designation level being sought. Photographs can be added to the **Finished Elevation Photos** portion of the form.



Technical Bulletin FH 2018-01

First Release:

March 20, 2018

Prepared by:

Fred Malik, Vice President,
FORTIFIED Building Programs

Applicable Standards:

FORTIFIED Home™–Hurricane

Applicable Designation Level:



New Documentation Requirements

Abstract

Metals exposed to salt and moisture in the air in coastal areas are highly susceptible to accelerated corrosion. The intent of this bulletin is to highlight the requirement for metal structural connections and materials fasteners used to retrofit or construct FORTIFIED buildings less than 3,000 ft. from saltwater to be suitably protected from corrosion. The corrosion resistance outlined in the FORTIFIED standards is not new; however, there are new documentation requirements.

Introduction

The minimum fastener and connector corrosion-protection retrofit requirements for FORTIFIED Home are outlined in Appendix D (page 85) of the FORTIFIED Home–Hurricane standards at DisasterSafety.org/wp-content/uploads/FORTIFIED-Home-Hurricane-Standards-2012.pdf.

Appendix D: Corrosion Protection Retrofit Requirements

Fasteners/ Connector	Structures within 300 ft. of saltwater	Structures more than 300 ft. but less than 1000 ft. from saltwater ¹	Structures more than 1000 ft. but less than 3000 ft. from saltwater	Structures more than 3000 ft. from saltwater
Roofing nails for shingles	Stainless steel	Stainless steel	Hot dip galvanized ⁴	Corrosion resistant ⁵
Concrete and clay roof tile fasteners	Stainless steel	Stainless steel	Hot dip galvanized ⁴	Corrosion resistant ⁵
Metal roof clips and fasteners (exposed)	Stainless steel	Stainless steel	Stainless steel	Corrosion resistant ⁵
Fasteners used for attachment of underlayment to roof deck	Hot dip galvanized ⁴	Hot dip galvanized ⁴	Hot dip galvanized ⁴	Corrosion resistant ⁵
Aluminum soffits	Not allowed	Not allowed	Not allowed	Allowed
Soffit and roof vent fasteners	Stainless steel	Stainless steel	Stainless steel	Corrosion resistant ⁵
Metal framing connectors, fasteners, anchors, and hangers in exposed areas ²	Stainless steel	Stainless steel	Stainless steel	Stainless steel or G185 galvanized
Metal framing connectors, fasteners, anchors, and hangers in vented enclosed areas ³	Stainless steel	Stainless steel or G185 galvanized coating	Stainless steel or G185 galvanized coating	Corrosion resistant ⁵



Corrosion-Resistant Fasteners

Technical Bulletin FH 2018-01

First Release:

March 20, 2018

Prepared by:

Fred Malik, Vice President,
FORTIFIED Building Programs

Applicable Standards:

FORTIFIED Home™–Hurricane

Applicable Designation Level:



¹Buildings on open, elevated foundations within 1,000 ft of saltwater shall follow the requirements of structures within 300 ft of saltwater.

²Examples of exposed areas include areas that are under roof overhangs, decks and covered walkways, or in any location that is openly or partially exposed to saltwater air.

³Examples of vented enclosed areas include attics with vents.

⁴Hot-dip galvanized shall meet the requirements of ASTM A153, Class D for nails and screws.

⁵Corrosion-resistant nails and screws shall meet the requirements of ASTM A641, Class 1 or an equal corrosion resistance by coating, galvanization, stainless steel, or other suitable corrosion-resistant material. Corrosion-resistant sheet metal connectors, anchors and hangers shall meet the requirements of ASTM A653, G90.

FORTIFIED Home Evaluators Only: New Applications & Evaluation Form Input

When a new residential application is made, a notification will appear if the address is within a coastal zip code. You will be asked to select one of four approximate distances from a shoreline.

3. Property Address

*Address Line1 :

Address Line2 :

*City :

*State :

*ZIP / Postal Code :

*Country :

Mailing Address If Mailing Address is

*Address Line1 :

Address Line2 :

NOTE: This home is in a coastal region. If the home is within 3000 linear feet of a salt water shore, special corrosion resistant requirements apply for all designation levels. See [Appendix D](#) of the FORTIFIED Standards - Hurricane.

Distance From Salt Water Shore:

- <Select>
- 300' or less
- More than 300' but less than 1000'
- More Than 1000' but less than 3000'
- More than 3000'

For reference, there is a direct weblink to Appendix D within the note.



Corrosion-Resistant Fasteners

Technical Bulletin FH 2018-01

First Release:

March 20, 2018

Prepared by:

Fred Malik, Vice President,
FORTIFIED Building Programs

Applicable Standards:

FORTIFIED Home™–Hurricane

Applicable Designation Level:



FORTIFIED Home Evaluators Only: Documentation Requirements

If the distance from a saltwater shoreline is MORE than 3,000 ft, no additional documentation is required. If the distance is LESS than 3,000 ft, documentation of the corrosion-resistant connections and fasteners used on the home is now required. This information will be entered on the first page of the evaluation.

The screenshot shows a web-based evaluation form. At the top, there are menu items: Errors, Save, Save & Exit, and Help. The form fields are as follows:
- Dwelling Type: Select Option (dropdown)
- Exposure Category: Select Option (dropdown)
- Finished Elevation Photos: Includes a photo upload icon and a text prompt: "Include at least 4 new photos of exposed connections" with another photo upload icon.
- Indicate the distance from salt water shore: A dropdown menu with the selected option "More Than 1000 ft but less than 3000 ft". A red arrow points to this dropdown.
- Year Built: Text input field.
- How was year built determined?: Text input field.
- Building Height (to the nearest foot): Text input field.
- Is structure supported by dry stack or unreinforced foundation?: Select Option (dropdown) with a photo upload icon.
- Wind Speed (ASCE 7-05): Text input field with the value "130".
At the bottom, there is a status bar with the ID "FEH36612020180000014" and the address "4824 yahoo ave, tampa Florida". The bottom navigation bar shows "Evaluation Profile" and "General/Site Information".

Photographs of labels, copies of invoices, and/or field delivery tickets indicating corrosion-resistance level for the connections and fasteners used are required. Photographs of the connections and fasteners should also be provided in this location.



Corrosion-Resistant Fasteners

Technical Bulletin FH 2018-01

First Release:

March 20, 2018

Prepared by:

Fred Malik, Vice President,
FORTIFIED Building Programs

Applicable Standards:

FORTIFIED Home™–Hurricane

Applicable Designation Level:



Examples

GULF SHORES, AL			
Sections		Notes	
Item Code	Description	Qty/Footage	Price
	EZ-FIT 17134 HDG 1-1/2"X.148 PP 2M JOIST HANGER NAIL 34DG	2 BOX	55
	EZ-FIT 650385 3X120 HDG RING 33D 2.5M/CTN	2 BOX	85
	EZ-FIT 650383 2-3/8"x.113 RS HDG 2.5M	2 BOX	65
	STAINLESS STEEL JOIST HANGER 17154 PNEU 1-1/2X148 1M	2 BOX	115
	MFM WIND AND WATER SHIELD SMOOTH 2SQ/F	4 EA	115
	FRM RT7A-SS STAINLESS STEEL HURRICANE C	100 EA	25
	SPF 2X6-18 #2 & BTR. SPRUCE-PINE-FIR	10 pc	15





Technical Bulletin FH 2018-02

First Release:

March 28, 2018

Prepared by:

Remington Brown,
Senior Engineering Director

Applicable Standards:

FORTIFIED Home™–Hurricane

Applicable Designation Level:



Gable End Overhangs and Roof Sheathing Fastening: Re-Roofing to Meet Bronze, New Roof Designation

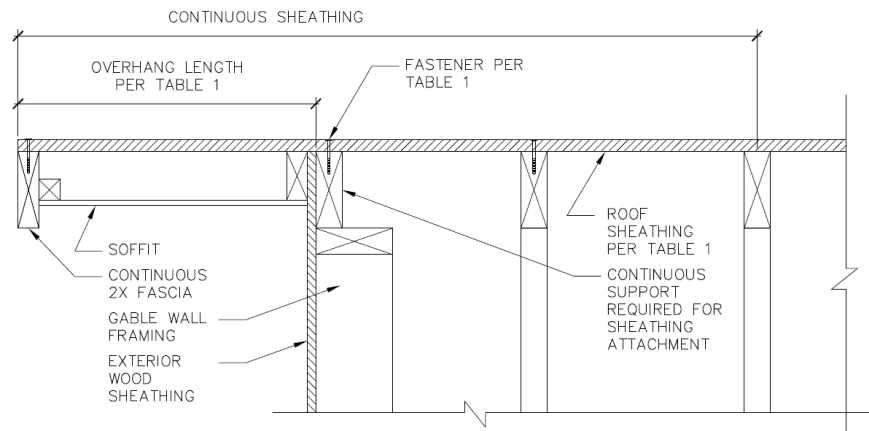

Applicable Conditions

1. Re-roofing projects only.
2. Bronze, new roof designation only. Silver or Gold designations for existing homes with gable overhangs greater than 12 in. require retrofit in accordance with [TB2017-02](#), revised March 21, 2018.

Abstract

Attachment requirements for roof sheathing along the gable end truss or rafter to achieve a FORTIFIED Home™–Hurricane Bronze new roof designation have been enhanced to allow roofers, in most cases, to complete necessary retrofits without having to engage a general contractor. Exceptions, which still require structural modifications by a general contractor, include vented gable rakes and gable ends with overhangs greater than those shown in Table 1 on page 2 of this document.



Technical Bulletin FH 2018-02

First Release:

March 28, 2018

Prepared by:

Remington Brown,
Senior Engineering Director

Applicable Standards:

FORTIFIED Home™–Hurricane

Applicable Designation Level:

BRONZE, New Roof Requirements

Roof sheathing shall be continuously fastened to the top of the gable wall with the minimum fastener size and spacing specified in Table 1 below. These solutions are limited to the maximum overhang length listed in Table 1 and to gable ends with roof sheathing continuously supported by and attached to the gable wall framing.

For gable rake overhangs exceeding the maximum overhang length in Table 1 or for unsupported gable rakes, a professional engineer must develop a building-specific solution.

Table 1. Roof Sheathing Minimum Fastening Requirements at the Gable Truss or Rafter

Roof Sheathing Thickness	Maximum Overhang Length	Attachment
7/16–1/2 in. OSB or plywood	18 in.	8d ring shank nails at 4 in. o.c.
19/32–3/4 in. OSB or plywood	18 in.	10d ring shank nails at 4 in. o.c.
1x6 or narrower planks	24 in.	(2) 10d common nails per plank
1x8 to 1x10 planks	24 in.	(3) 10d common nails per plank

Compliance Verification Requirements

The re-nailing of the deck at all applicable gable end overhangs is to be documented and verified by a certified FORTIFIED evaluator. Acceptable documentation includes but may not be limited to the following:

- Pictures of roof deck nailed in accordance with Table 1.
- Size, type and spacing of the fastener attaching the roof sheathing to the gable end must be listed in the RE-NAILING section of the Roofing Compliance Form.



Completing Evaluation Form (For FORTIFIED Evaluators Only)

Technical Bulletin FH 2018-02

First Release:

March 28, 2018

Prepared by:

Remington Brown,
Senior Engineering Director

Applicable Standards:

FORTIFIED Home™–Hurricane

Applicable Designation Level:



In the FOCUS software:

Photos showing roof sheathing attachment at the gable wall that clearly illustrate the fastener spacing conforms to Table 1 requirements must be uploaded by the Evaluator as additional photos in the Roof Deck section of FOCUS under “Roof deck fastener count.”

Roof deck fastener count in 48" location 1

From inside the attic, if adequate access exists, verify roof sheathing is supported at the top of the gable wall. If roof sheathing support at the gable end wall cannot be verified from within the attic, evaluator should select “Partial” under Attic Accessibility, in the Roof Deck portion of the evaluation form. Then describe limited access (e.g., Gable end sheathing support cannot be verified due to limited attic access).

Attic accessibility

If access is Partial or None, describe what restricts access? (Type n/a, if not applicable)