



INSTALLATION MANUAL

JET PUMPS

CONSUMER HOT-LINE: 1-800-942-3343 • MONDAY - FRIDAY • 7 AM to 5 PM

**EASTERN
STANDARD
TIME**

SHALLOW WELL PUMP

MODEL RTS5 1/2 HP
MODEL RTS7 3/4 HP
MODEL RTS10 1 HP

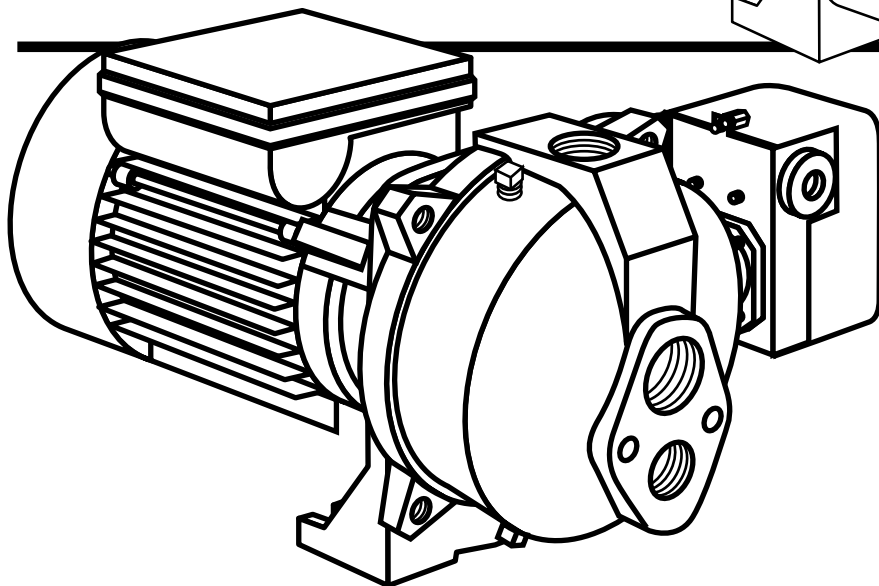
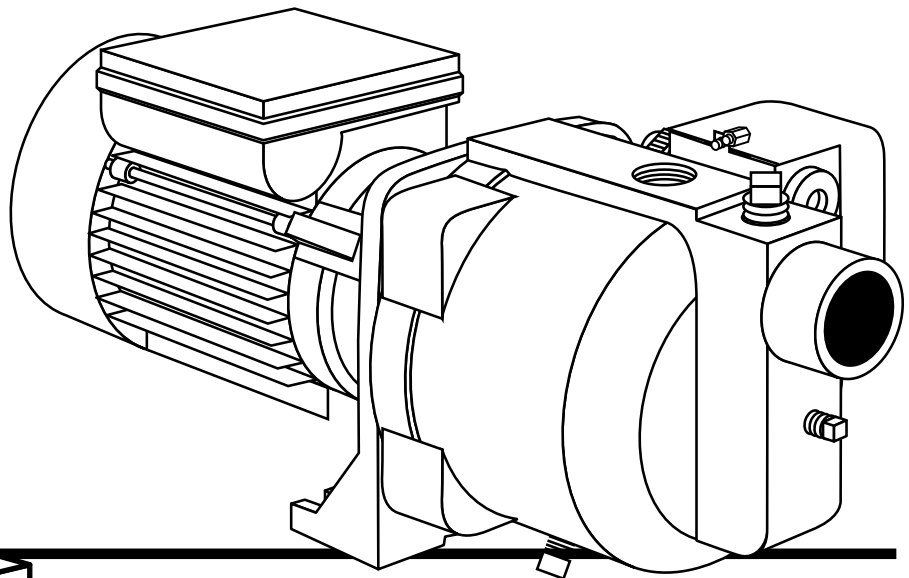

DEEP WELL PUMP

**MODEL RC10
CONVERTIBLE
1 HP**
**MODEL RC5
CONVERTIBLE
1/2 HP**



WARRANTY: PRODUCT DEFECTS COVERED 12 MONTHS FROM DATE OF PURCHASE OR 18 MONTHS FROM DATE OF MANUFACTURE. RECEIPT AND PRODUCT DATE CODE REQUIRED FOR WARRANTY CLAIM.

WATER ACE PUMP COMPANY • ASHLAND, OHIO 44805-1969

IMPORTANT INSTRUCTIONS BEFORE INSTALLATION

Failure to follow these instructions may cause serious bodily injury and/or property damage.



WARNING Warranty void if product modified, drilled, painted, or altered in any way; if used to pump hot water, or to pump liquids other than water (such as but not limited to chemicals, fertilizers, flammable liquids, herbicides, mud, tar, cement, wood chips); or otherwise abused.

1. Before installing or servicing your pump, BE CERTAIN pump power source is disconnected.
2. All installation and electrical wiring must adhere to state and local codes and must be complete before priming the pump. Check with appropriate community agencies, or contact your local electrical and pump professionals.
3. Pump should be installed in a dry, convenient location which is close to the well and provides ample space for installation and servicing the well. A dry basement, pit, or utility room is an excellent choice when allowed by law.
4. **CALL AN ELECTRICIAN WHEN IN DOUBT.** Pump motor should be connected to a separate electrical circuit directly from main switch. There must be a fuse box or circuit breaker installed in this line. Plugging into existing outlets may cause low voltage at motor, resulting in blown fuses, tripping of motor overload, or burned out motor. **Refer to electrical diagrams on following page for electrical connections.**
5. It is mandatory that a permanent ground connection be made from the pump motor to the grounding bar at the service panel. Do not connect pump motor to a power supply until permanently grounded. For maximum safety, ground the pump motor to a circuit equipped with a fault interrupter device.
6. **Motor Grounding Instructions: WARNING** Reduced risk of electric shock during operation of this pump requires the provision of acceptable grounding. **Caution: Failure to ground this unit properly may result in severe electrical shock.** If the means of connection to the supply-connection box is other than grounded metal conduit, ground the pump motor back to the service by connecting a copper conductor, at least the size of the circuit conductors supplying the pump motor, to the grounding screw provided within the wiring compartment. NOTE: N.E.C. requires pumps be grounded at installation.

CAUTION



Pump must be primed! Make sure pump is full of water before running! Failure to do so will cause damage to mechanical seal, leakage and flooding!



Never run pump against closed discharge valve! To do so can cause high temperatures, pump damage, personal injury and property damage!



WARNING Hazardous voltage! Can shock, burn or cause death. Read instructions before installing!



To avoid dangerous or fatal shock hazard turn off power and ground motor before connecting motor to electrical power supply!



Do not ground to a gas supply line!



Match supply voltage to nameplate voltage. Wrong voltage can cause fire or motor damage and voids warranty. If in doubt, consult a licensed electrician.



Pump may be **HOT** to touch. Use caution!

7. Voltage of power supply must match the voltage of the pump. The 1/2 HP pump motors are factory preset to 115V. The 3/4 and 1 HP pump motors are preset to 230V. Both types of motors may be wired for either 115V or 230V. If the motor is converted to 115V, electrician should insure that electrical and power leads can handle the higher amps.
8. During installation, cover well to prevent foreign matter from contaminating the well or later damaging the pump during operation. Test well water for purity. Chlorination may be necessary. Check local Health Department for proper testing and recommendations.
9. Hand pump new wells until clear. Sand or other sediment will seriously damage the pump.
10. The following may cause severe damage to pump and/or piping and will void warranty:
 - Failure to protect pump and piping against below freezing temperatures.
 - Pumping chemicals or corrosive liquids.
 - Running the pump dry. Follow priming instructions on pages 5 or 8, depending on the installation.
11. Do NOT use extension cords.
12. Do NOT pump gasoline or other flammable liquids.
13. Do NOT use this pump in or near a swimming pool, lake or pond.

FINDING THE DEPTH OF YOUR WELL

Tie a small but heavy weight to the end of a piece of string (be sure there is enough string; some wells are very deep). Lower the weight into the well until it reaches the bottom. Take up the slack and mark the string at ground level. Pull the weight out of the well and measure from the bottom of the weight to the ground level mark. This is the depth of your well. Subtract five feet from the depth of your well. This number should not exceed the maximum rated depth for your pump. If it does, it will greatly hinder or prevent the proper operation of the pump.

SHALLOW WELL PUMP CAPACITIES

FOR RTS5 (1/2 HP), RTS7 (3/4 HP) & RTS10 CONVERTIBLE (1 HP)

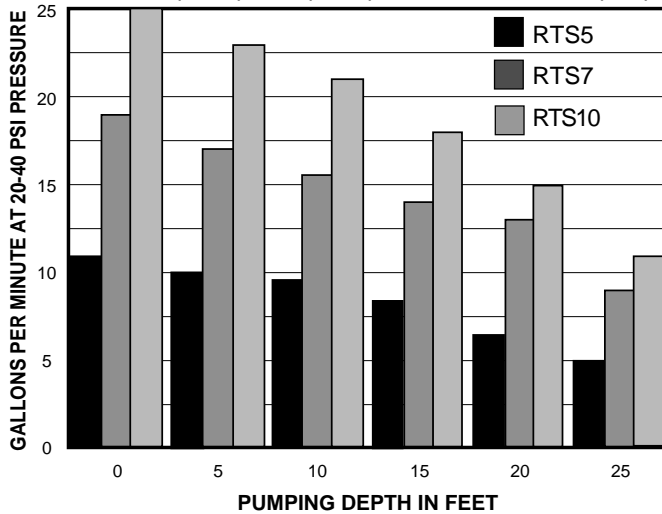

DEEP WELL PUMP CAPACITIES

FOR RC5 (1/2 HP) & RC10 CONVERTIBLE (1 HP)

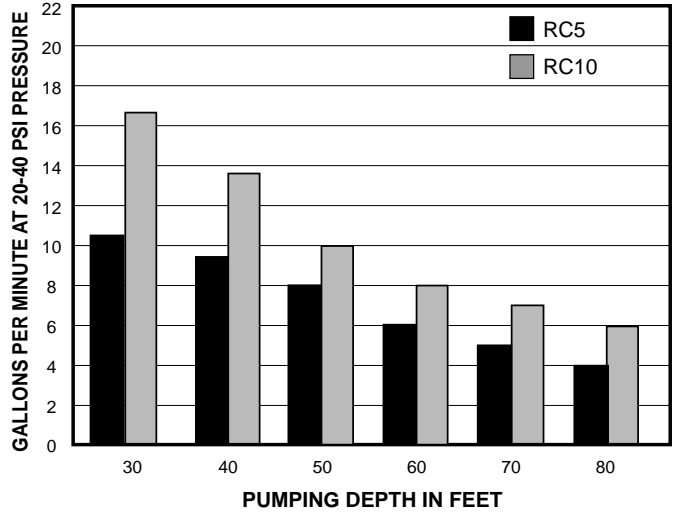

IMPORTANT SELECT CORRECT VOLTAGE

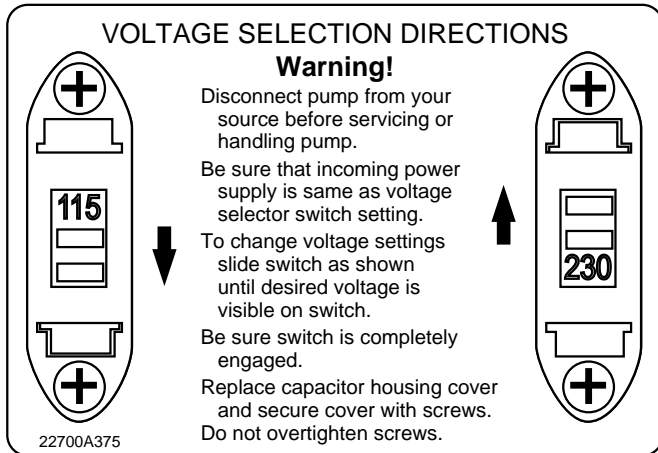

Disconnect pump from power source before changing the pump voltage. To change the voltage, the selector switch is located underneath the plastic cover on top of the motor. To access the switch, remove the four screws holding the plastic cover. To change the voltage setting, slide the switch as shown until desired voltage is visible on the switch. The voltage number that appears is the voltage setting for the pump. Be sure the switch is completely engaged. Replace the capacitor cover and secure the cover with the four screws.

WIRE SELECTION GUIDE

PUMP MODEL	HORSE POWER	VOLTAGE	NAME PLATE AMPS	MAX. WIRE LENGTH IN FEET USING AWG SIZE			
				#14	#12	#10	#8
RTS5 or RC5	1/2	115	8.6	118	189	296	464
		230	4.3	475	756	1184	1857
RTS7	3/4	115	11.2	100	160	250	385
		230	5.6	400	630	1000	1545
RTS10 or RC10	1	115	12.6	84	135	211	331
		230	6.3	339	540	845	1327

FUSE AND CIRCUIT BREAKER SIZE GUIDE

HORSE POWER	STANDARD LINE PLUG FUSE*		LOW PEAK - CART. TYPE FUSETRON - CART. TYPE FUSTAT - PLUG TYPE*		CIRCUIT BREAKER	
	115V	230V	115V	230V	115V	230V
1/2	20	10	12	6-1/4	20	15
3/4 & 1	30	15	20	10	30	15

*For circuits not over 150 volts to ground.

WIRING YOUR PUMP

Disconnect pump from power before servicing or handling pump. Remove the cover from the pressure switch. Connect the bare copper ground to the ground screw in the pressure switch. Connect the power supply to the terminals marked "Line" in the diagram below.

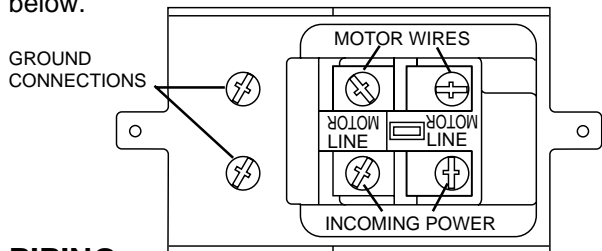

PIPING

Plastic PVC pipe is shown in the illustrations, but galvanized steel pipe may be used if desired. All piping must be clean and free of all foreign matter to prevent clogging. **ALL JOINTS AND CONNECTIONS IN THE WELL ASSEMBLY MUST BE AIRTIGHT.** Even a pin-hole leak will prevent the proper operation of the pump (this is the most common problem). Use thread compound on all threaded joints unless specified otherwise.

DRAINING FOR SERVICING OR FOR WINTER

The pump should be drained before it is disconnected for servicing or if it is in danger of freezing. To drain:

- Remove drain plug from bottom of pump case.
- Remove discharge tee to vent the pump.
- Drain all piping to a point 3 feet (1 meter) below ground level.

SHALLOW WELL PUMP INSTALLATION (4" DIAMETER CASED WELL)

For wells 25 feet or less in depth, the 1/2 HP RTS5, 3/4 HP RTS7 and 1 HP RTS10 pumps are recommended. However, the 1 HP RC10 and 1/2 HP RC5 convertible pumps may be adapted to shallow wells with ejector kits R-E100 and R-E520 respectively. All materials with part numbers are quality Water Ace parts.

General Materials

- One can PVC cement (read instructions carefully)
- One can thread compound (read instructions carefully)
- One 1-1/4" foot valve RFV-12
- Two male 1-1/4" PVC adapters
- Enough rigid 1-1/4" PVC pipe and couplings to reach from bottom of well to pump.
- One 4" well seal RWS4-12 with vent plug
- One 1-1/4" PVC elbow
- One discharge tee RDT

- One pressure gauge RG-2
- One male 1" PVC adapter
- Enough rigid 1" PVC pipe to reach from pump to pressure tank to service line.
- One female 1" PVC adapter
- One 1" tank cross RTC290-1 (for diaphragm tanks)
- Two 1/4" plugs
- One 1/2" drain cock
- One 10" x 1" nipple

In addition to General Materials, for the RC10 and RC5 Convertible only

One ejector kit R-E100 or R-E520; includes ejector, venturi tube, gasket, bolts, plug, tubing, and fittings.

Tools Needed for all pump installations

Pipe wrench, pipe clamp, crescent wrench, slot screwdriver, 24-tooth hacksaw, knife or round file.

REMINDER: ALL JOINTS AND CONNECTIONS MUST BE AIRTIGHT. A SINGLE PIN-HOLE LEAK WILL PREVENT THE PROPER OPERATION OF THE PUMP. USE THREAD COMPOUND ON ALL THREADED CONNECTIONS UNLESS SPECIFIED OTHERWISE.

STEP 1 Thread 1-1/4" male PVC adapter into foot valve RFV-12. Hand tighten, then tighten 1/4 turn with crescent wrench.

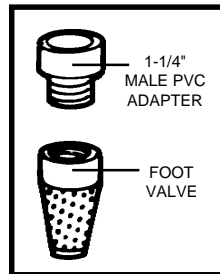

STEP 2 Subtract four feet from the depth of your well (See page 1 "Finding the Depth of Your Well"). This is the total length of rigid PVC pipe and couplings to cement onto the 1-1/4" male PVC adapter. Cement one section of rigid PVC pipe to the PVC adapter which is connected to the foot valve, then lower the whole assembly into the well, foot valve first. Firmly clamp the end of the rigid PVC pipe with a pipe clamp to prevent the assembly from sliding down into the well.

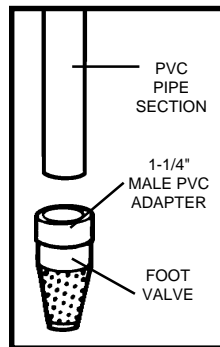

STEP 3 Cement as many couplings and sections of rigid PVC pipe as it takes to equal the depth of your well minus four feet, then firmly clamp the assembly with a pipe clamp to prevent the assembly from sliding down into the well.

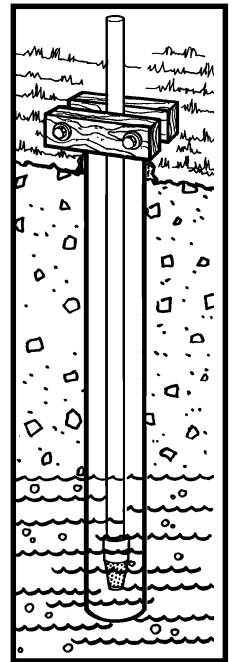

STEP 4 Remove pipe clamp and slide well seal RWS4-12 over rigid PVC pipe and onto well casing. Position assembly so that twelve inches of rigid PVC pipe protrude from well seal. Alternately turn bolts on well seal counterclockwise until rubber gaskets are tight against well casing and rigid PVC pipe.

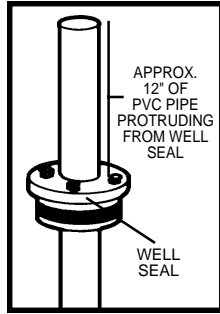

STEP 5 Cement 1-1/4" PVC elbow onto rigid PVC pipe protruding from well seal. If desired, some length may be cut off of rigid PVC pipe before cementing elbow. Smooth the inside of any rigid PVC pipe that has been cut with a round file or knife.

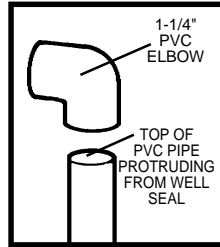

STEP 6 If you are using the RTS5, RTS7 or RTS10 pump, thread a 1-1/4" male PVC adapter into the front of it. Hand tighten, then turn 1/4 turn with crescent wrench.

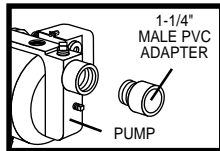

STEPS 7-12 FOR THE RC5 & RC10 CONVERTIBLE PUMPS

STEP 7 Open ejector kit (R-E520 for RC5 pump with venturi tube part #1, shorter tube), (R-E100 for RC10 pump with venturi tube part #1, shorter tube). Thread venturi tube into ejector until snug. Place gasket over venturi tube so that openings in gasket line up with openings in ejector.

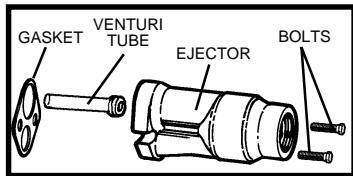

STEP 8 Slide bolts through the bolt openings on either side of the ejector, through the gasket and bolt ejector to front of the pump. Tighten bolts securely.

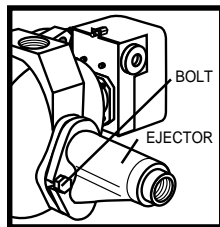

STEP 9 Thread a 1-1/4" male PVC adapter into front of ejector. Hand tighten, then turn 1/4 turn with wrench.

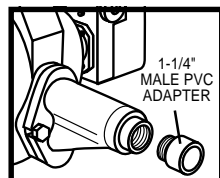

STEP 10

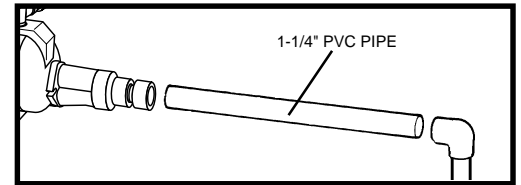

Cement as many sections and couplings of PVC pipe needed to connect the PVC elbow to the 1-1/4" male PVC adapter in the front of the pump.

PRIMING SHALLOW WELL JET PUMPS

STEP 11 Using pipe wrench, thread 1" discharge tee RDT into top of pump. Remove pressure gauge plug from top of discharge tee. **TO PRIME:** Put a garden hose into top of discharge tee and fill pipes and pump until water overflows from top of discharge tee. This may take several minutes.

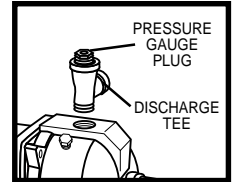

STEP 12 Thread pressure gauge plug back into discharge tee and thread pressure gauge RG-2 into pressure gauge plug. Make sure all connections are tightly sealed.

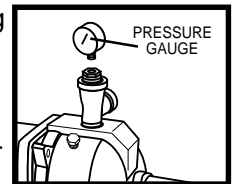

STEP 13 Complete all electrical connections as specified on pages 1 and 2 in the pre-installation instructions.

STEP 14 Place a large bucket beneath discharge tee outlet. Start motor. If pump is off-set from well 4 feet or more, it may take a few minutes for pump to prime. **Failure to prime in 5 minutes:** Stop motor, remove pressure gauge plug from discharge tee, add more water, try again.

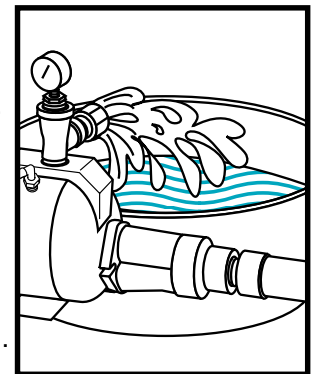

STEP 15 Allow pump to run long enough to clear the well of sand or dirt and to insure well will not run dry. Stop motor. Screw 1" male PVC adapter into discharge tee outlet.

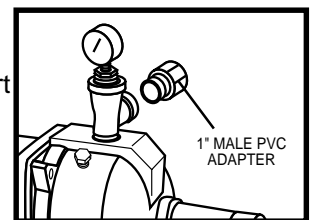

STEP 16 Thread 10" x 1" nipple into pressure tank. Thread tank cross RTC-290-1 into nipple so that the two 1/4" holes in tank cross face upward. Plug two outlets on tank cross with two 1/4" plugs.

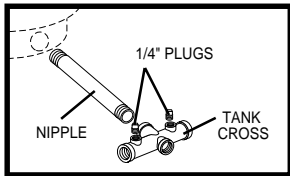

STEP 17 Thread 1/2" boiler drain into front of tank cross. Thread 1" male PVC adapter into inlet side of tank cross.

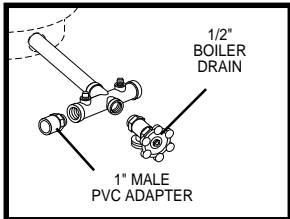

STEP 18 Cement as many sections and couplings of rigid 1" PVC pipe needed to connect the 1" male PVC adapter in the discharge tee to the 1" male adapter on the tank cross inlet. Set pressure in the diaphragm pressure tank to 2 pounds less than the cut-in pressure of the pump. The cut-in pressure of all Water Ace pumps is factory preset to 20 PSI. If this cut-in setting has not been changed, then the diaphragm pressure tank should be set to 18 PSI. Total installation should look like the shallow well drawing below.

WELL POINT PUMP INSTALLATION

Materials needed in addition to Shallow Well General Materials, for Well Points only

- Enough galvanized 1 1/4" pipe and unions to reach from bottom of well to one foot above ground level
- One 1-1/4" galvanized elbow
- One 1-1/4" galvanized nipple
- One 1-1/4" check valve RCV-12
- One 1-1/4" male PVC adapter

STEP 1: Drive the well point into the ground according to the instructions included with your well point. Use as much galvanized pipe and unions as it takes to both reach the water and leave approximately one foot of pipe protruding from the ground.

STEP 2: Thread 1 1/4" galvanized elbow onto the pipe protruding from the ground.

STEP 3: Thread 1-1/4" galvanized nipple into the 1-1/4" galvanized elbow.

STEP 4: Thread 1-1/4" check valve onto the 1-1/4" galvanized nipple.

STEP 5: Thread 1-1/4" male PVC adapter into the 1-1/4" check valve.

STEP 6: FOLLOW STEPS 6-20 IN SHALLOW 4" DIAMETER CASED WELL INSTRUCTIONS. Total installation should look like the drawing below.

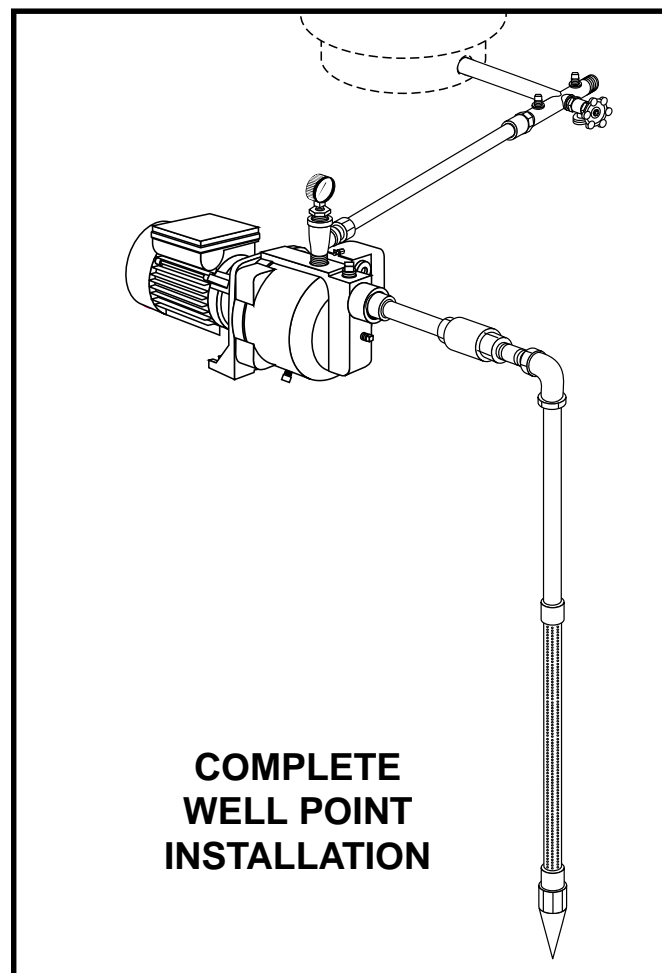
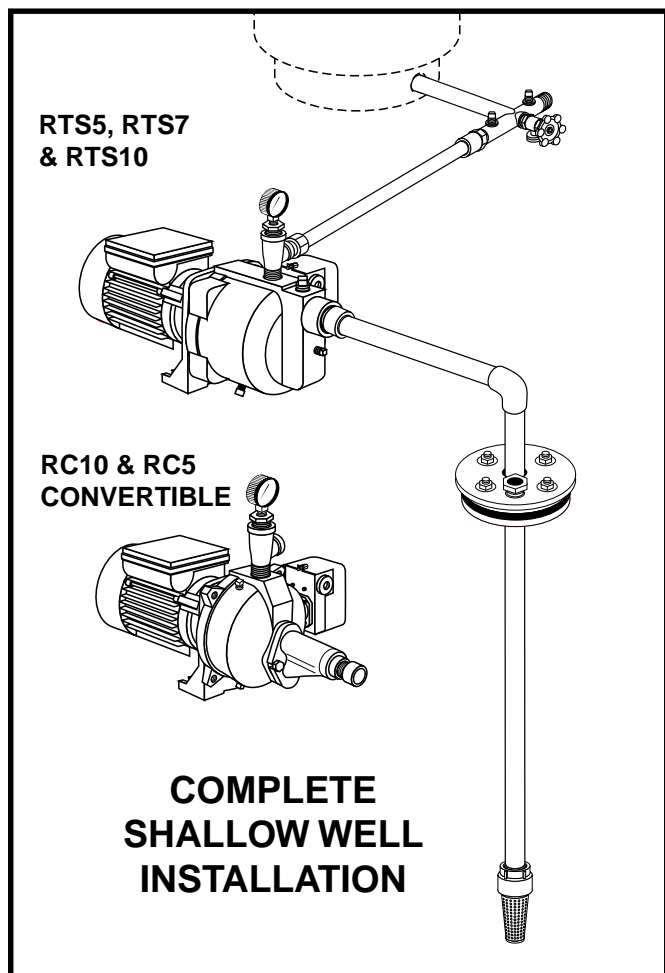

DEEP WELL PUMP INSTALLATION (4" DIAMETER CASED WELL)

For wells over 25, but not exceeding 80 feet in depth, the 1 HP RC10 Convertible Deep Well Pump is recommended. However, the 1/2 HP RC5 Deep Well Pump may also be used for depths not exceeding 70 feet. Materials with part numbers are quality Water Ace parts.

General Materials Needed for either the RC5 or RC10 convertible pumps

- One can PVC cement (read instructions carefully)
- One can thread compound (read instructions carefully)
- Two 1" female PVC adapters
- Enough rigid 1-1/4" PVC pipe and couplings to reach from bottom of well to pump (delivery pipe)
- One 1-1/4" PVC elbow
- One 1-1/4" male PVC adapter
- One pressure regulator Kit RPR (includes fittings, tubing, and 1/4" plug)
- One pressure gauge RG-2
- Two male 3/4" PVC adapters
- Enough rigid 3/4" PVC pipe to reach from pump to pressure tank to service line

- Tank tee RTT1-LF (for diaphragm pressure tanks)
- Two 1/4" plugs
- One 1/2" drain cock

In addition to General Materials for RC10 & RC5

- One 1-1/4" foot valve RFV-12
- One 1-1/4" close nipple
- One ejector (R-E100 for RC10) (R-E520 for RC5)
- One 1" x 5" nipple
- One 1-1/4" female adapter
- One well seal RWS4-1012
- Enough rigid 1" PVC pipe and couplings to reach from bottom of well to pump (pressure pipe)
- One 1" PVC elbow
- Two 1-1/4" male PVC adapters
- One 1" x 4" nipple

REMINDER: ALL JOINTS AND CONNECTIONS MUST BE AIRTIGHT. A SINGLE PIN-HOLE LEAK WILL PREVENT THE PROPER OPERATION OF THE PUMP. USE THREAD COMPOUND ON ALL THREADED CONNECTIONS UNLESS SPECIFIED OTHERWISE.

TO INSTALL THE RC10 & RC5 CONVERTIBLE

- STEP 1** Thread 1-1/4" close nipple into foot valve RFV-12. Thread the other end of 1-1/4" close nipple into bottom of twin ejector. Hand tighten, then tighten 1/4 turn with pipe wrench.

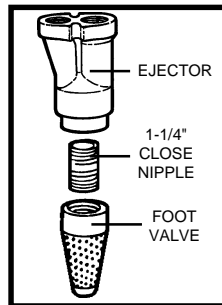

- STEP 2** The ejector has two holes in the top of it. Thread deep well venturi tube (part #2 longer tube for R-E520, part #2 longer tube for R-E100) into larger hole until snug. Thread 1" x 5" nipple into smaller hole. Only hand tighten venturi tube. Tighten nipple 1/4 turn with pipe wrench.

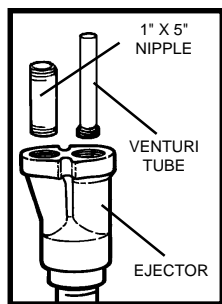

- STEP 3** Thread a 1-1/4" male PVC adapter over the venturi tube and into ejector. Thread a 1" female PVC adapter onto the 1" x 5" nipple. Tighten adapters 1/4 turn with crescent wrench.

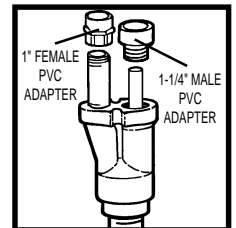

- STEP 4** Subtract five feet from the depth of your well. This is the total length of PVC pipe and couplings to cement onto both 1-1/4" male and 1" female PVC adapters. Cement a section of PVC pipe to each adapter, then lower the whole assembly into the well, foot valve first. Firmly clamp the end of the PVC pipes with a pipe clamp to prevent the assembly from sliding down into well.

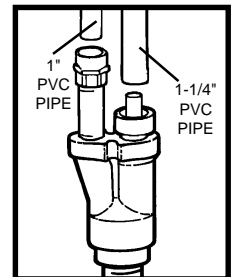

STEP 5 Cement as many couplings and sections of rigid PVC pipe on both the pressure and delivery sides as it takes to equal the depth of your well minus four feet, then firmly clamp the assembly with a pipe clamp to prevent the assembly from sliding down into the well. Be sure to keep track of which pipe is the pressure pipe and which is the delivery pipe.

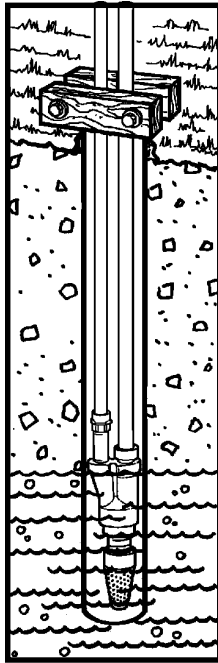

STEP 6 Remove pipe clamp and slide well seal RWS4-1012 over PVC pipes and onto well casing. DO NOT let assembly slide down into well. Position assembly so that twelve inches of PVC pipes protrude from well seal. Using crescent wrench, turn bolts on well seal counterclockwise until rubber gaskets are tight against the well casing and the PVC pipes.

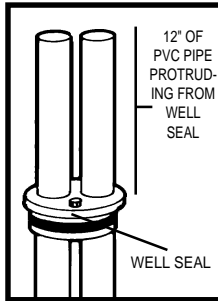

STEP 7 Cut 1" pipe 2" shorter than the 1-1/4" pipe. Smooth rough edges. Cement 1" and 1-1/4" PVC elbows to pipes protruding from the well seal.

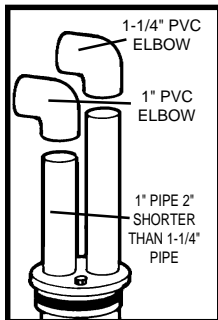

STEP 8 Thread a 1-1/4" male PVC adapter into top hole in front of pump. Thread 1" x 4" nipple into bottom hole in front of pump. Thread the 1" female PVC adapter onto the 1" x 4" nipple.

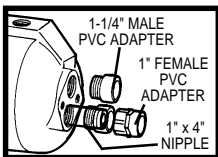

STEP 9

Cement as many sections and couplings of rigid 1" and 1-1/4" PVC needed to connect the 1" female PVC adapter and the 1-1/4" male PVC adapter to the 1" and 1-1/4" PVC elbows.

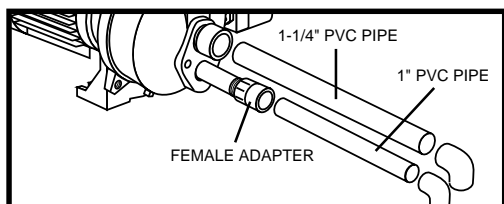

STEP 10 Open pressure regulator kit RPR. With pipe wrench, thread the pressure regulator into 1" discharge at top of pump. Thread pressure gauge RG-2 into side of pump case.

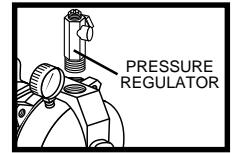

STEP 11 Thread plug into opening to right of pressure regulator outlet.

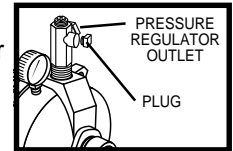

PRIMING DEEP WELL JET PUMPS

STEP TO PRIME: 12 Remove pressure regulator, put a garden hose into the top of the pump discharge and fill pipes and pump with water until water overflows from top of pump. This may take several minutes. Put regulator back on pump.

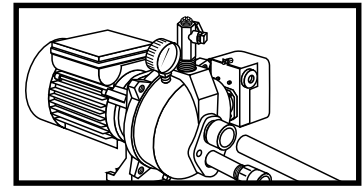

STEP 13 Complete all electrical connections as specified on pages 2 and 3 in the pre-installation instructions.

STEP 14 Place a large bucket beneath the pressure regulator outlet. Start motor. Turn regulator adjustment screw down tight. If pump is properly primed a high pressure will immediately show on the pressure gauge. With pump operating at high pressure, slowly unscrew regulator stem until maximum water flow is obtained without pressure dropping to zero. If pressure falls completely, retighten stem and readjust. **Steady pressure must not be less than 24 lbs. for the RC5 and 32 lbs. for the RC10. If no pressure shows:** Stop motor, remove pressure regulator from pump, add more water, and try again.

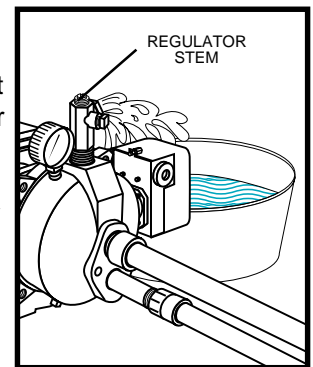

STEP 15 Allow pump to run long enough to clear well of sand or dirt and to insure well will not run dry. Stop motor. Thread 3/4" male PVC adapter into pressure regulator outlet.

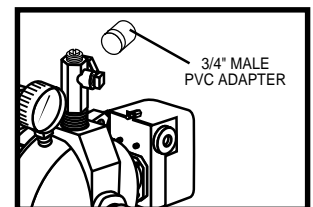

STEP 16 Thread tank tee RTT1-LF into diaphragm pressure tank. Plug two outlets on tank tee with two 1/4" plugs.

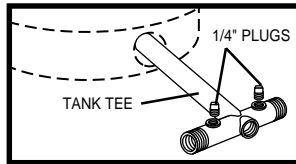

STEP 17 Thread boiler drain into front of tank tee. Thread 3/4" male PVC adapter into inlet side of tank tee.

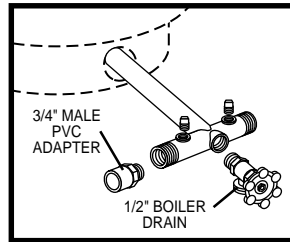

STEP 18 Cement as many sections and couplings of rigid 3/4" PVC pipe needed to connect the 3/4" male PVC adapter in the discharge tee to the 3/4" male adapter on the tank tee inlet. Set pressure in the diaphragm pressure tank to 2 pounds less than the cut-in pressure of the pump. The cut-in pressure of all Water Ace pumps is factory preset to 20 PSI. If this cut-in setting has not been changed, then the diaphragm pressure tank should be set to 18 PSI. Total installation should look like the drawing at right.

CAUTION: If you change pressure switch settings, set the cut-off pressure low enough to shut off the pump. If a valve shuts off and the cut-off setting is too high, the pump will run continuously without water flow causing overheating and serious damage.

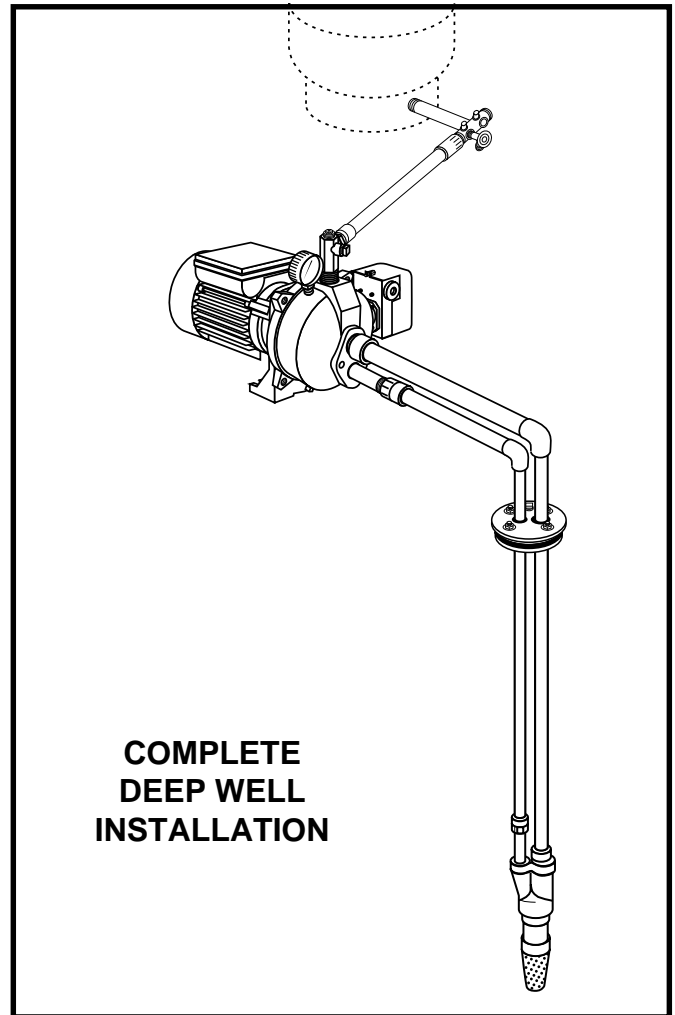

DEEP WELL PACKER PUMP INSTALLATION (2" DIAMETER CASED WELL)

For wells over 25, but not exceeding 80 feet in depth, the 1 HP RC10 Convertible Deep Well Pump is recommended. However, the 1/2 HP RC5 Deep Well Pump may be used as well for depths not exceeding 70 feet. Materials with part numbers are quality Water Ace parts.

General Materials Needed for either RC5 or RC10

- One can PVC cement (read instructions carefully)
- One can thread compound (read instructions carefully)
- One foot valve RFV-10
- Two 1" male PVC adapters
- Two 1" female PVC adapters
- One 1" x 8" nipple
- One 2" packer well adapter kit RWA-2 (includes adapter, adapter gasket, compression plate, compression gasket, 3/4" plug, nuts and bolts)
- Two 1-1/4" male PVC adapters
- Enough rigid 1-1/4" PVC pipe and couplings to reach from packer well adapter to pump (delivery pipe)
- One pressure regulator kit RPR (includes fittings, tubing, and 1/4" plug)
- One pressure gauge RG-2

- Enough rigid 1" PVC pipe and couplings to reach from bottom of well to packer well adapter, and from pump to pressure tank to service line.
- One 1" x 11" tank tee RTC290-1 (for diaphragm tanks)
- Two 1/4" plugs
- One 1/2" drain cock

In addition to General Materials for RC10 & RC5

- One packer ejector kit (RP2-7-10 for RC10 includes ejector, venturi tube, and fitting); (RP2-3-5 for RC5 includes ejector, two venturi tubes, and fitting)
- One 1-1/4" male PVC adapter
- One 1-1/4" to 1" PVC reducer
- Enough rigid 1" PVC pipe and couplings to reach from packer well adapter to pump (pressure pipe)
- One 1" female PVC adapter
- One 1" x 4" nipple

Optional: 2" adapter plate RPA for direct connection to packer well adapter (includes adapter plate, gasket, and bolts. See "Alternate Pump/Packer Connection" on page 11.

REMINDER: ALL JOINTS AND CONNECTIONS MUST BE AIRTIGHT. A SINGLE PIN-HOLE LEAK WILL PREVENT THE PROPER OPERATION OF THE PUMP. USE THREAD COMPOUND ON ALL THREADED CONNECTIONS UNLESS SPECIFIED OTHERWISE.

TO INSTALL THE RC10 & RC5

- STEP 1** Open packer ejector kit. Thread foot valve RFV-10 onto packer ejector. Thread the venturi tube into other side of packer ejector.

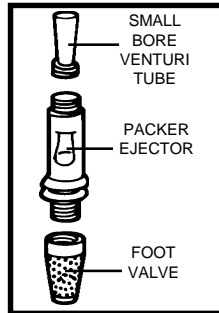

- STEP 2** Slide the fitting from packer ejector kit over venturi tube and thread onto packer ejector. Thread a 1" male PVC adapter into the brass fitting.

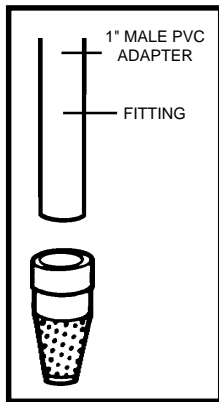

- STEP 3** Subtract seven feet from the depth of your well. This is the total length of rigid 1" PVC pipe and couplings to cement onto the 1" male PVC adapter. Cement one section of rigid PVC pipe to the male PVC adapter, then lower the whole assembly into the well, foot valve first. Firmly clamp the end of the rigid PVC pipes with a pipe clamp to prevent the assembly from sliding down into the well. Cement as many couplings and sections of rigid 1" PVC pipe as it takes to equal the depth of your well minus seven feet, then firmly clamp the assembly with a pipe clamp to prevent the assembly from sliding down into the well. Clamp the assembly so approximately twelve inches of rigid 1" PVC pipe protrudes from the well.

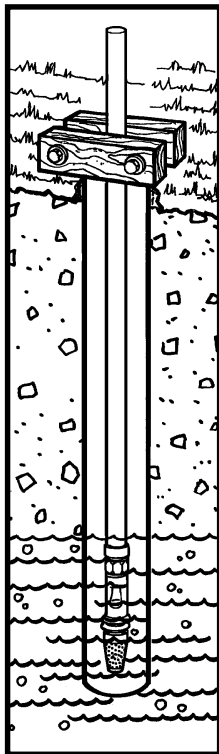

- STEP 4** Open packer well adapter kit RWA-2. Slide compression plate and rubber compression gasket over rigid 1" PVC pipe protruding from well.

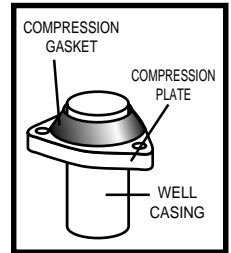

- STEP 5** Thread 1" x 8" nipple into bottom of packer well adapter. Thread 1" female PVC adapter onto 1" x 8" nipple. Thread 3/4" plug into top of packer well adapter.

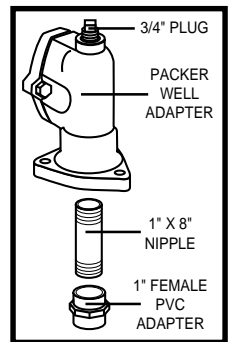

- STEP 6** Cement packer well adapter assembly to top of rigid 1" PVC pipe protruding from well.

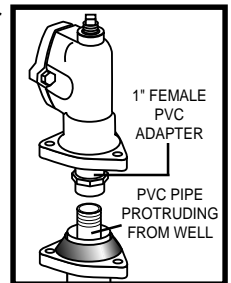

- STEP 7** Remove pipe clamp. Line up the holes in well casing, compression plate, and packer well adapter and fasten them together with the three nuts and bolts provided in packer well adapter kit RWA-2.

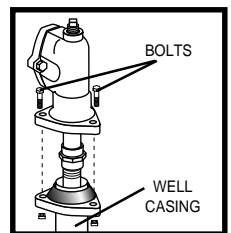

- STEP 8** Thread two 1-1/4" male PVC adapters into front of packer well adapter. The top hole is for the delivery pipe. The bottom hole is for the pressure pipe.

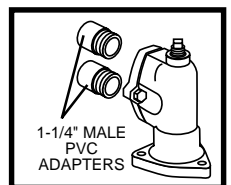

- STEP 9** Cement the 1-1/4" to 1" PVC reducer to the bottom male PVC adapter on the packer well adapter.

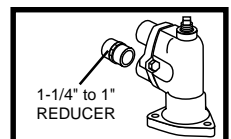

STEP 10 Thread the 1-1/4" male PVC adapter into top hole in front of the pump. Thread 1" x 4" nipple into bottom hole in front of the pump.

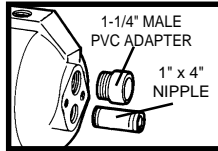

STEP 11 Thread the 1" female PVC adapter onto the 1" x 4" nipple.

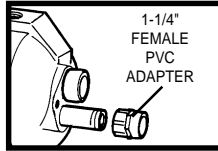

STEP 12

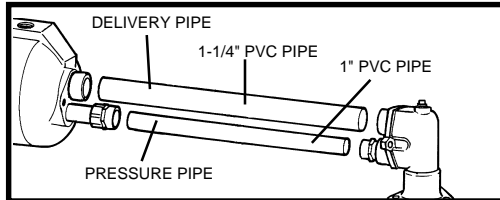

Cement as many sections and couplings of 1-1/4" PVC pipe as needed to connect top male 1 1/4" PVC adapter on front of the pump to top male 1-1/4" PVC adapter on front of packer well adapter. Cement as many sections and couplings of 1" PVC pipe as needed to connect 1" female PVC adapter on 1" x 4" nipple to 1-1/4" to 1" PVC reducer on front of packer well adapter. (FOLLOW STEPS 10-19 IN THE RC10 4" DIAMETER DEEP WELL PUMP INSTALLATION INSTRUCTIONS on pages 8 and 9. Complete installation should look like drawing to the right.)

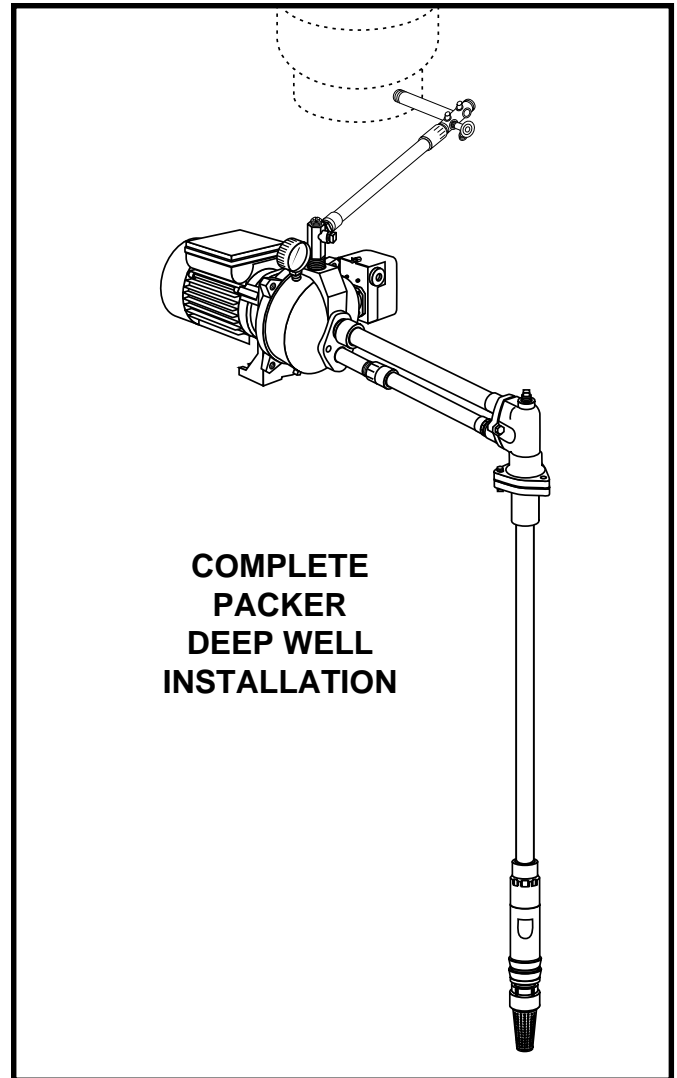

ALTERNATE PACKER/PUMP CONNECTION FOR RC10 & RC5

The Adapter Plate RPA connects directly to packer well adapter. Position adapter plate gasket between pump and adapter plate (large holes of adapter plate should face away from pump). Bolt adapter plate to front of pump with two allen bolts included with Adapter Plate RPA, then bolt packer well adapter to adapter plate.

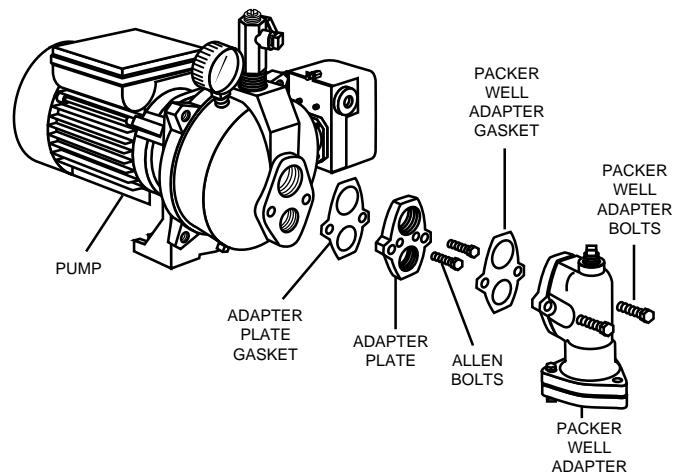

TROUBLESHOOTING CHECKLIST (CAUTION: SHUT OFF POWER TO PUMP)

PROBLEM	POSSIBLE CAUSES
Pump will not prime	<ul style="list-style-type: none"> • Not enough water. Stop motor, remove pressure gauge plug, and fill case and suction line with water. • Pump wired incorrectly. • Plugged venturi tube or nozzle. • Foot valve is sitting in sand or mud, or is stuck shut, or leaks. • Low well water level. In deep wells, the ejector as well as the foot valve must be below water level. • For the RC10 & RC5, the diffuser O-ring seal may be improperly positioned. • Air leaks. Check all connections for airtightness.
Pump delivers water for a period of time, then stops pumping	<ul style="list-style-type: none"> • Low well water level. Use a water-level tester while pump is operating. • Plugged venturi tube, nozzle, or impeller parts. • In deep wells, the regulator may be set incorrectly. See Step 14 in the 4" diameter Deep Well Installation Instructions.
Pump does not deliver rated capacity	<ul style="list-style-type: none"> • Plugged venturi or nozzle. • Faulty pressure gauge resulting in false readings. • In deep wells, the operating pressure may be too high. See Step 14 in the 4" diameter Deep Well Installation Instructions. • Low well water level. Use a water-level tester while pump is operating. • For the RC10 & RC5, the diffuser O-ring seal may be improperly positioned. • Over-submergence of ejector. In deep wells, if ejector is more than 10 feet below pumping level, pumping capacity is reduced. • In deep wells, the ejector may have improper size and depth setting.
Motor overheats and shuts off (overload)	<ul style="list-style-type: none"> • Motor voltage does not match power supply voltage. See pages 2 and 3. • Improper wire size. See Wire Size Guide on page 3. • Impeller is rubbing against pump case.
Pump delivers water but will not shut off	<ul style="list-style-type: none"> • Impeller neck is worn. • Defective pressure switch. • For the RC10 & RC5, the O-ring seal may be improperly positioned. • Tank precharge pressure too high. Tank precharge pressure must be 1-2 pounds less than switch turn-on setting. • In deep wells, the water level may be going below limit of ejector. Use water-level tester while pump is operating.
Pressure switch turns on and off every few seconds	<ul style="list-style-type: none"> • Galvanized storage tank is waterlogged. • Leaky foot valve. • Too much tank pressure.
Motor fails or does not operate properly	<ul style="list-style-type: none"> • If within Warranty, return pump/motor unit to place of purchase (with proof of purchase) for exchange.

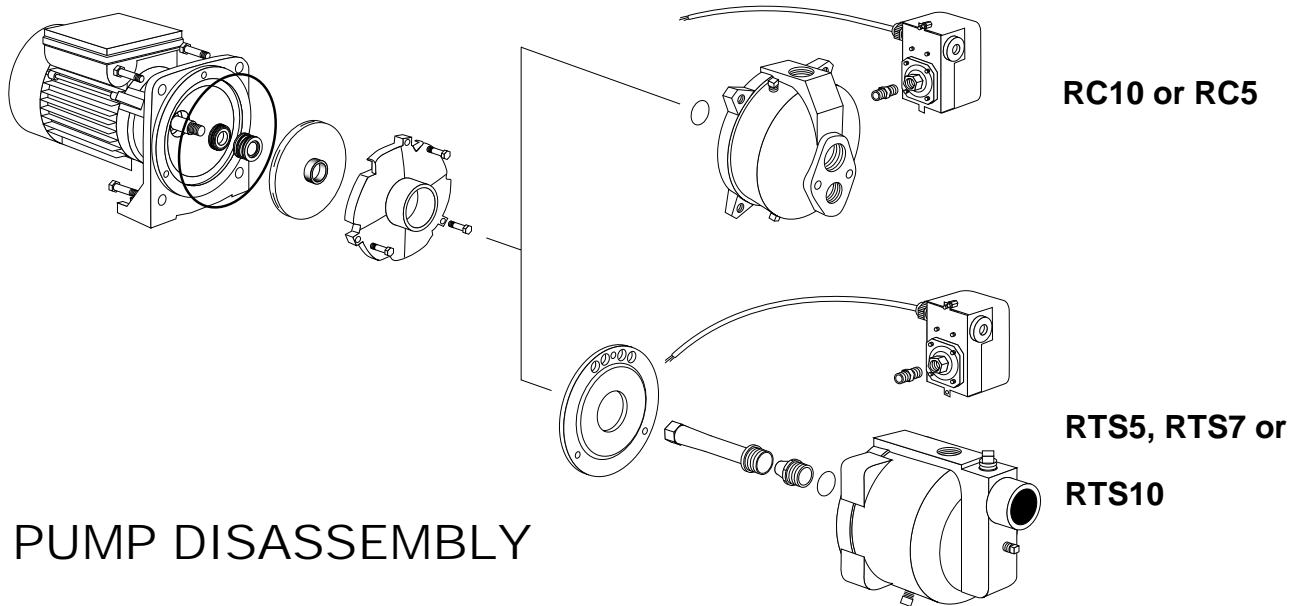

PUMP DISASSEMBLY

REPAIR KITS

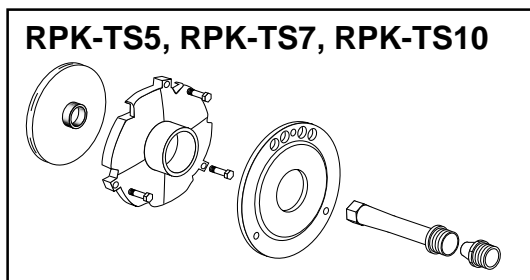

REPAIR KITS FOR RTS5, RTS7, RTS10 & RC5 PUMPS

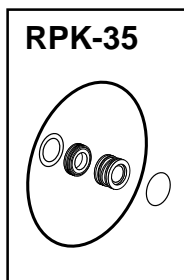

REPAIR KIT FOR THE RC10 PUMP

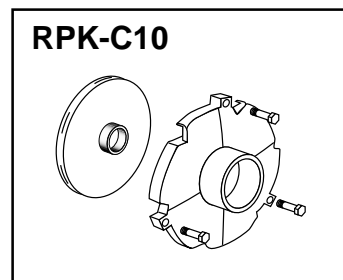

LIMITED WARRANTY

WATER ACE PUMP CO. will repair or replace for the original user any portion of a new WATER ACE product which proves defective due to materials or workmanship of WATER ACE PUMP CO. Contact the nearest authorized WATER ACE PUMP dealer for warranty service. WATER ACE PUMP CO. shall possess the sole right to determine whether to repair or replace defective equipment, parts or components. **THIS WARRANTY DOES NOT COVER DAMAGE DUE TO LIGHTNING OR OTHER CONDITIONS BEYOND THE CONTROL OF WATER ACE PUMP CO.**

PUMPS: Warranted 12 months from date of purchase or 18 months from date of manufacture. Receipt and product date code required for warranty claim.

LABOR & COSTS: WATER ACE PUMP CO. shall IN NO EVENT be liable for the cost of field labor or other charges incurred by any customer in removing and/or reaffixing any WATER ACE PUMP product, part or component.

THIS WARRANTY WILL NOT APPLY: (a) to defects or malfunctions resulting from failure to properly install, operate, or maintain the unit in accordance with printed instructions provided; (b) to failures resulting from abuse, accident, or negligence; (c) to normal maintenance services and the parts used in connection with such service; (d) to units which are not installed in accordance with applicable local codes, ordinances, and good trade practices; (e) if the unit is moved from its original installation location; (f) if unit is used for purposes other than for what it was designed and manufactured.

PRODUCT IMPROVEMENTS: WATER ACE PUMP CO. reserves the right to change or improve its products or any component without obligation to provide such a change or improvement for units previously sold and/or shipped.

WARRANTY EXCLUSIONS: WATER ACE PUMP CO. SPECIFICALLY DISCLAIMS THE IMPLIED WARRANTIES OF MERCHANTABILITY AND FITNESS FOR A PARTICULAR PURPOSE AFTER THE TERMINATION OF THE WARRANTY PERIOD SET FORTH HEREIN.

Some states do not permit some or all of the above warranty limitations and, therefore, such limitations may not apply to you. No warranties or representations at any time made by any representatives of WATER ACE PUMP CO. shall vary or expand the provision hereof.

LIABILITY LIMITATION: IN NO EVENT SHALL WATER ACE PUMP CO. BE LIABLE OR RESPONSIBLE FOR CONSEQUENTIAL, INCIDENTAL OR SPECIAL DAMAGES RESULTING FROM OR RELATED IN ANY MANNER TO ANY WATER ACE PUMP PRODUCT OR PARTS THEREOF. PERSONAL INJURY AND/OR PROPERTY DAMAGE MAY RESULT FROM IMPROPER INSTALLATION. WATER ACE PUMP CO. DISCLAIMS ALL LIABILITY, INCLUDING LIABILITY UNDER THIS WARRANTY, FOR IMPROPER INSTALLATION – WATER ACE PUMP CO. RECOMMENDS FOLLOWING THE INSTRUCTIONS IN THE INSTALLATION MANUAL. WHEN IN DOUBT, CONSULT A PROFESSIONAL.

Some states do not allow the exclusion or limitation of incidental or consequential damages, so the above limitation or exclusion may not apply to you.

This warranty gives you specific legal rights and you may also have other rights which vary from state to state.

In the absence of suitable proof of this purchase date, the effective date of this warranty will be based upon the date of manufacture.

Direct all Notices, etc. to: Product Warranty and Return Dept., Water Ace Pump Co., 1101 Myers Parkway, Ashland, OH 44805-1969.