

Southern Nevada District Board of Health

REGULATIONS GOVERNING INDIVIDUAL SEWAGE DISPOSAL SYSTEMS AND LIQUID WASTE MANAGEMENT

ADOPTED JULY 24, 1984 | AMENDED APRIL 28, 1994

REVISED FEBRUARY 26, 2009



Southern Nevada Health District
P.O Box 3902
Las Vegas, NV 89127
(702) 759-0588

Environmental Health Division | Engineering and Plan Review Section
Individual Sewage Disposal Systems Program
(702) 759-0660

SOUTHERN NEVADA HEALTH DISTRICT

REGULATIONS GOVERNING INDIVIDUAL SEWAGE DISPOSAL SYSTEMS AND LIQUID WASTE MANAGEMENT

WHEREAS, the Southern Nevada Health District (SNHD) has been established by the County of Clark and the cities of Las Vegas, North Las Vegas, Henderson, Mesquite, and Boulder City as the public health authority for those entities, and pursuant to Nevada Revised Statutes (NRS) Chapter 439; has jurisdiction over all public health matters in the health district; and

WHEREAS, the Southern Nevada District Board of Health (Board) is the governing body of the SNHD, and is authorized to adopt regulations to regulate sewage disposal and liquid waste management in the interest of the public health, and to protect and promote the public health and safety in the geographical area subject to the jurisdiction of the health district; and

WHEREAS, the Board finds that individual sewage disposal systems and liquid waste management impacts the public health, and finds that it is necessary to adopt Southern Nevada Health District Regulations Governing Individual Sewage Disposal Systems and Liquid Waste Management to regulate the construction, operation and servicing of septic tanks and soil absorption systems, or other sewage treatment systems, and liquid waste management; and

WHEREAS, the Board finds that the following Regulations are designed to protect and promote the public health and safety, it does therefore publish, promulgate and order compliance within Clark County, Nevada with the substantive and procedural requirements hereinafter set forth.

INTENT AND SCOPE

Intent The purpose of these Regulations is to protect and promote the public health, safety, and environment through preventative measures and timely correction of public health and environmental issues relating to individual sewage disposal systems and liquid waste management.

Scope These Regulations establish definitions; set standards for the location, design, construction, operation, and maintenance of individual sewage disposal systems; provide for the issuance, modification and revocation of permits.

These Regulations also set standards for liquid waste management, the operation and permitting of liquid waste haulers; provide for the issuance, modification, suspension and revocation of liquid waste hauler permits.

PREFACE

A properly planned, maintained, and installed individual sewage disposal system will:

- 1) Promote the health and welfare of citizens of this Health District by preventing the pollution of ground and surface water.
- 2) Prevent nuisances;
- 3) Eliminate hazards to the public health by minimizing pollution of water supplies and hazards to recreational areas; and
- 4) Minimize disease transmission potential.

It is the policy of the Southern Nevada Health District, therefore, to eliminate and prevent public health and safety hazards by regulating proper planning, design, construction, operation and maintenance of individual sewage disposal systems. This will be achieved through plan review, the issuance of permits and field surveillance.

The most satisfactory method of sewage disposal is by connection to a public sewer system. Where such systems exist, every effort should be made to secure sewer extensions. When connection to a public sewerage is not feasible, particularly where a large number of residences are to be served, consideration should be given to the construction of a community sewerage system and treatment plant. Specific information on this matter may be obtained from the Southern Nevada Health District.

The Southern Nevada District Board of Health having considered and taken into account the geological, hydrological, and topographical characteristics within the area of its jurisdiction, adopts the following Regulations Governing Individual Sewage Disposal Systems and Liquid Waste Management and orders compliance with the terms and provisions thereof which shall become effective upon the date of passage and approval of the Southern Nevada District Board of Health pursuant to its statutory authority as set forth in **Nevada Revised Statute (NRS) 444.650**.

TABLE OF CONTENTS

Section 1 GENERAL PROVISIONS

Definitions

- 1.1 “Absorption trench” defined.
- 1.2 “Additive” defined.
- 1.3 “Aeration risers” defined.
- 1.4 “Acre site” defined.
- 1.5 “Aerobic bacteria” defined.
- 1.6 “Aerobic wastewater treatment system unit” defined.
- 1.7 “Anaerobic bacteria” defined.
- 1.8 “Alternative absorption system” defined.
- 1.9 “Alternative treatment system” defined.
- 1.10 “Approved water source” defined.
- 1.11 “Backwash” defined.
- 1.12 “Bedrock” defined.
- 1.13 “Biochemical oxygen demand (BOD)” defined.
- 1.14 “Biomat” defined.
- 1.15 “Block wall” defined.
- 1.16 “Cease and desist order” defined.
- 1.17 “Caliche” defined.
- 1.18 “Capacity of septic system” defined.
- 1.19 “Chamber leach field” defined.
- 1.20 “Commercial facility” defined.
- 1.21 “Commercial holding tank” defined.
- 1.22 “Community sewerage system” defined.
- 1.23 “Composting toilet” defined.
- 1.24 “Cone of influence letter” defined.
- 1.25 “Constructed wetland” defined.
- 1.26 “Deep absorption system” defined.
- 1.27 “De-nitrification” defined.
- 1.28 “Distribution box” defined.
- 1.29 “Distribution line” defined.
- 1.30 “District” defined.
- 1.31 “Domestic sewage” defined.
- 1.32 “Dosing tank” defined.
- 1.33 “Drip field” defined.
- 1.34 “Effluent” defined.
- 1.35 “Facultative bacteria” defined.
- 1.36 “Fixture unit (FU)” defined.
- 1.37 “Geo-textile fabric” defined.
- 1.38 “Grinder pump” defined.
- 1.39 “Health Authority” defined.
- 1.40 “Holding tank” defined.

- 1.41 **“Individual sewage disposal system (ISDS)” defined.**
- 1.42 **“Inlet and Outlet tees” defined.**
- 1.43 **“Impervious material” defined.**
- 1.44 **“Influent” defined.**
- 1.45 **“Leach field” defined.**
- 1.46 **“Lift pump” defined.**
- 1.47 **“Lot” defined.**
- 1.48 **“Mound or Septic mound system” defined.**
- 1.49 **“Natural drainage channel” defined.**
- 1.50 **“Nitrogen removal system” defined.**
- 1.51 **“Percolation rate” defined.**
- 1.52 **“Percolation test” defined.**
- 1.53 **“Person” defined.**
- 1.54 **“Pipe and gravel leach field” defined.**
- 1.55 **“Potable water” defined.**
- 1.56 **“Public health hazard” defined.**
- 1.57 **“Repair of ISDS” defined.**
- 1.58 **“Retaining wall” defined.**
- 1.59 **“Right-of-way” defined.**
- 1.60 **“Sand filter septic system” defined.**
- 1.61 **“Sand layer” defined.**
- 1.62 **“Scum” (also referred to as “FOG”) defined.**
- 1.63 **“Seepage bed” defined.**
- 1.64 **“Seepage pit” defined.**
- 1.65 **“Septic system” defined.**
- 1.66 **“Septic tank” defined.**
- 1.67 **“Septic tank pumping contractor” defined.**
- 1.68 **“Shall” defined.**
- 1.69 **“Sequencing batch reactor” defined.**
- 1.70 **“Sewage” defined.**
- 1.71 **“Shallow absorption system” defined.**
- 1.72 **“Sludge” defined.**
- 1.73 **“Soil absorption system” defined.**
- 1.74 **“Soil permeability” defined.**
- 1.75 **“Streets” defined.**
- 1.76 **“Structure” defined.**
- 1.77 **“Subsurface drip disposal system (SDD)” defined.**
- 1.78 **“Substantially compliant” defined.**
- 1.79 **“Sweeping Tee” defined.**
- 1.80 **“System failure” defined.**
- 1.81 **“Tenant improvement” defined.**
- 1.82 **“Test hole” defined.**
- 1.83 **“Total nitrogen (TN)” defined.**
- 1.84 **“Total suspended solids (TSS)” defined.**
- 1.85 **“Tree” defined.**
- 1.86 **“Vapor barrier” defined.**

- 1.87 **“Wastewater” defined.**
- 1.88 **“Watercourse” defined.**
- 1.89 **“Waters of the state” defined.**
- 1.90 **“Water softener” defined.**
- 1.91 **“Water table” defined.**
- 1.92 **“Waterproof” defined.**

Section 2 PERMIT TO CONSTRUCT – APPLICATION REQUIREMENTS

- 2.2 Residential ISDS Permit
- 2.3 Commercial ISDS Permit
- 2.4 Commercial Holding Tank Permit

Section 3 TENANT IMPROVEMENT APPLICATIONS

Section 4 CERTIFICATION OF INDIVIDUAL SEWAGE DISPOSAL SYSTEMS (ISDS)

- 4.4 ISDS Certification Procedure
- 4.5 Water Well Certification Procedure

Section 5 LOCATION OF INDIVIDUAL SEWAGE DISPOSAL SYSTEMS

TABLE I Minimum Horizontal Separations

Section 6 SPECIFICATIONS FOR SEPTIC TANKS

- 6.3 Septic Tank Construction
- 6.9 Septic Tank Dimensions

TABLE II Estimated Waste / Sewage Flow Rates

TABLE III Quantity of Sewage Flow per Fixture

TABLE IV Septic Tank Capacities

- 6.11 Inlets and Outlet Tees; Baffles
- 6.12 Manholes

Section 7 MAINTENANCE AND SLUDGE DISPOSAL

Section 8 DISTRIBUTION BOX

Section 9 EFFLUENT DISPOSAL

- 9.1 Location and Method
- 9.2 Pipe and Gravel Leach Fields
- 9.3 Chamber System Leach Fields
- 9.4 Seepage Pits
- 9.5 Subsurface Drip Disposal Systems (SDD)
- 9.6 Mound Systems
- 9.7 Absorption Trenches

- 9.8 Aerobic Treatment Units (ATU)
- 9.9 Absorption Area
- TABLE V Required Absorption Field Area for Pipe and Gravel Leach Fields,
Seepage Pits and Trenches

- 9.9.1 Dosing Tanks

- 9.10 Sand Layer Requirement

Section 10 NITROGEN REMOVAL SYSTEMS

- 10.2 Approval of Nitrogen Removal Systems
- 10.3 NSF Certification
- 10.4 Design of Nitrogen Removal Systems
- 10.5 Installation Requirements
- 10.6 Operation and Maintenance
- 10.7 Annual Nitrogen Removal System Surveillance
- 10.8 Revocation of Nitrogen Removal System Permits

Section 11 SPECIFIC LIMITATIONS AND REQUIREMENTS

- 11.22 Lot Size (s) Requirement

Section 12 SEWER CONNECTION

Section 13 INDUSTRIAL WASTES

Section 14 LAND SLOPE REQUIREMENTS

- 14.2 Supplemental Horizontal Requirements

Section 15 SOIL PERCOLATION RATES AND SOIL CHARACTERIZATION

- 15.1 Soil Boring and Percolation Tests
- 15.2 Percolation Test Procedure
- 15.3 Soil Borings
- 15.4 Soil Characterization

Section 16 INSPECTION OF INDIVIDUAL SEWAGE DISPOSAL SYSTEMS

Section 17 REMOVAL AND ABANDONMENT OF SEPTIC TANK AND LEACH FIELD

- 17.2 Abandonment of Septic Tank and Leach Field in Place
- 17.3 Removal of Septic Tank and Leach Field

Section 18 SOLID AND LIQUID WASTES: GENERATED FROM SEPTIC TANK, HOLDING TANK, CHEMICAL TOILET WASTE, OR GREASE INTERCEPTOR TANK OR INEDIBLE KITCHEN GREASE CONTAINERS, AND PUMPING AND HAULING CONTRACTORS (INCLUDING PETROLEUM HYDROCARBON CONTAMINATED WASTE WHICH MAY BE GENERATED BY SAND-OIL-WATER SEPARATORS)

- 18.2 Permit Requirements
- 18.3 Septic tank waste
- 18.4 Chemical toilet waste
- 18.5 Holding tank waste
- 18.6 Grease interceptor waste
- 18.7 Inedible kitchen waste
- 18.8 Industrial liquid waste
- 18.9 Vehicle identification
- 18.10 Vehicle maintenance
- 18.11 Portable receptacles
- 18.12 Disposal site
- 18.13 Record keeping requirements concerning inedible kitchen grease
- 18.14 Documentation and filing of reports
- 18.15 Automatic shutoffs
- 18.16 Suspension or Revocation of Waste Permittees' Permits

Section 19 HEARING AND APPEALS

- 19.2 Application for Variances
- 19.3 Notice of Hearing
- 19.4 The Hearing
- 19.5 Criteria
- 19.6 The Order
- 19.7 Duration of Variance
- 19.8 ISDS Hearing Officer Process

Section 20 INTERPRETATION AND SEVERABILITY

LIST OF FIGURES

- FIGURE 1 Typical Plot Plan
- FIGURE 2 Two Compartment Tank
- FIGURE 2A Individual Sewage Disposal Systems
- FIGURE 3 Distribution Box
- FIGURE 4 Pipe and Gravel System
- FIGURE 5 Chamber System
- FIGURE 6 Rectangular Leach Pit
- FIGURE 7 Absorption Trench
- FIGURE 8 Supplemental Horizontal Requirement
- FIGURE 9 Grease Interceptor
- FIGURE 10 Sand Layer Detail (Chamber System)
- FIGURE 10A Sand Layer Detail (Pipe and Gravel System)
- FIGURE 11 Aeration Riser Details
- FIGURE 12 Vapor Barrier Details
- FIGURE 13 Leach Field Area Requirements

Section 1

GENERAL PROVISIONS

Summary of acronyms and abbreviations of terms used in these Regulations

Board	Southern Nevada District Board of Health
EPA	United States Environmental Protection Agency
NRS	Nevada Revised Statutes
RCRA	Resource Conservation and Recovery Act
mg/L	Milligrams per Liter
mL	Milliliters
SNHD	Southern Nevada Health District
NDEP	Nevada Division of Environmental Protection

Definitions. As used in these Regulations, unless the context otherwise requires, the following words and terms defined have the meanings ascribed to them in this document as they pertain to individual sewage disposal systems (ISDS).

1.1 **“Absorption trench” defined.** A system of soil absorption using a trench not over thirty-six inches (36”) in width with a minimum of eighteen inches (18”) of clean, coarse aggregate under a distribution pipe and covered with a minimum of twelve inches (12”) of earth cover, that utilizes the soil for subsequent absorption and treatment of septic tank effluent. The maximum length of perforated pipe shall be one hundred feet (100’) per trench

1.2 **“Additive” defined.** Also referred to as septic additive, septic chemical, septic treatment, septic tank additive: A septic additive is a chemical, bacteria, or other product sold to be placed into a septic tank or septic absorption system, purportedly to improve the function of the system, improve leach field performance, avoid septic tank pumping, or other repair or maintenance need. The use of additives in septic systems in Clark County is not recommended.

1.3 **“Aeration risers” defined.**

- With a Pipe and Gravel Leach Field:
Pipes extending from the end of perforated pipes vertically with a solid 90 degree bend and a solid pipe to perforated pipes within 12” of the surface encased in a 24” x 24” x 24” cube with ½” to 2 ½” gravel.
- With a Chamber Leach Field:
Pipes extending from the top of chambers vertically with solid 90 degree bend and a solid pipe to perforated pipes within 12” of the surface encased in a 24” x 24” x 24” cube with ½” to 2 ½” gravel.

- 1.4 **“Acre site” defined.** This consists of 43,560 square feet of land and includes any public streets, alleys, rights-of-way, and easements.
- 1.5 **“Aerobic bacteria” defined.** Bacteria that require free dissolved oxygen for growth.
- 1.6 **“Aerobic wastewater treatment system unit” defined.** This is a chamber that receives sewage and through oxidation, decomposes the sewage by the mechanical (pump) introduction of air into the wastewater to reduce both the level of total suspended solids and the level of biological oxygen demand to thirty (30) milligrams or less per liter.
- 1.7 **“Anaerobic bacteria” defined.** Bacteria that grow only in the absence of free dissolved oxygen. Bacteria that obtain oxygen from breaking down complex organic substances.
- 1.8 **“Alternative absorption system” defined.** This is a system other than an absorption trench that uses the native soil for the subsequent absorption and treatment of effluent from a primary treatment unit. The term includes, without limitation, a capping fill trench, composting toilet, constructed wetlands, stepped absorption system utilizing relief lines, subsurface drip disposal system, sand filter and elevated mound system, and any other system not addressed in these Regulations.
- 1.9 **“Alternative treatment system” defined.** A system or a receptacle other than a septic tank that is designed and constructed to: receive the discharge of sewage from a building sewer; partially or completely treat such sewage; and discharge effluent for final disposal.
- 1.10 **“Approved water source” defined.** An individual sewage disposal system permit or tenant improvement approval cannot be issued without a guarantee of potable water from a municipal source or a well in good standing with the Nevada Division of Water Resources.
- 1.11 **“Backwash” defined.** This is normally highly concentrated wastewater generated from the cleaning of water and wastewater treatment filters. Backwash from pools and water softeners into the septic system is prohibited.
- 1.12 **“Bedrock” defined.** Bedrock is defined as materials which generally cannot be excavated with normal power-excavating equipment. In the case of badly creviced sandstone or granite, andesite, etc., and for limestone or shale, bedrock is considered to be present when fifty percent (50%) of the material has rock-like characteristics even though it can be excavated. Cemented soils, sometimes termed as caliche, occurring in layers and lenses with soil found below the cemented deposit shall not be defined as bedrock.
- 1.13 **“Biochemical oxygen demand (BOD)” defined.** This is the difference between the initial dissolved oxygen in a sample and the dissolved oxygen in a duplicate sample after a stated period of time, usually over a period of five (5) days.
- 1.14 **“Biomat” defined.** A biological layer formed by anaerobic bacteria. They secrete a gluey substance to anchor themselves to the soil or rock particles.

- 1.15 **“Block wall” defined.** A free standing wall constructed with concrete masonry unit (CMU) block and a concrete foundation.
- 1.16 **“Cease and desist order” defined.** A **Cease and Desist Order** is a written Order issued by the Health Authority which directs the responsible person to stop causing or allowing a violation of these or any applicable Regulations on a property. As specified in the **Cease and Desist Order**, a timeframe to achieve compliance with the Order may be included.
- 1.17 **“Caliche” defined.** This is a hardened deposit of calcium carbonate. This calcium carbonate cements together other materials, including gravel, sand, clay, and silt.
- 1.18 **“Capacity of septic system” defined.** This is the maximum volume of wastewater a septic system is designed to be capable of handling.
- 1.19 **“Chamber leach field” defined.** A chamber leach field is an absorption field consisting of leaching chambers. A leaching chamber is a wastewater treatment system consisting of beds, together with one or more distribution pipes or open-bottomed plastic chambers, installed in appropriate soils. These chambers receive wastewater flow from a septic tank or other treatment device and transmit it into soil for final treatment and disposal.
- 1.20 **“Commercial facility” defined.** Any structure or building(s), mobile home parks or any portion thereof, other than a residential single family dwelling or residential accessory structure, as defined by the Building Department.
- 1.21 **“Commercial holding tank” defined.** This is a non-residential, above ground holding tank for the containment of wastewater on a temporary basis and must be pumped periodically.
- 1.22 **“Community sewerage system” defined.** Any system owned and operated by a public entity such as a general improvement districts, sanitation districts, city, county or state governments.
- 1.23 **“Composting toilet” defined.** A manufactured turnkey or kit form treatment technology that receives human waste from a waterless toilet directly into an aerobic composting chamber where dehydration and biological activity reduce the waste volume and the content of nutrients and harmful microorganisms to an appropriate level for later disposal.
- 1.24 **“Cone of influence letter” defined.** A letter signed and sealed by a State of Nevada registered professional engineer stating the separation distance, leach field depth if applicable, and that the stress influence of the building foundation will not adversely affect the leach field and/or septic tank and the stress influence of the leach field and/or septic tank will not adversely affect the building foundation. This letter is required when the setbacks to the building foundation are closer than minimum requirements stated in these Regulations.

- 1.25 **“Constructed wetland” defined.** This is an engineered wastewater treatment system designed to simulate natural wetlands. This wetland consists of former upland environments that have been modified to create poorly drained soils and wetlands flora and fauna for the primary purpose of wastewater treatment.
- 1.26 **“Deep absorption system” defined.** A leach field developed to a depth of more than fifty-four inches (54”) below the final grade.
- 1.27 **“De-nitrification” defined.** This is the systematic removal of nitrogen from wastewater, which normally involves anaerobic bacteria.
- 1.28 **“Distribution box” defined.** A watertight structure, which receives sewage from a septic tank and distributes such sewage in theoretically equal portions to pipelines leading to the disposal area.
- 1.29 **“Distribution line” defined.** Pipe used for dispersion of septic tank effluent into leach fields.
- 1.30 **“District” defined.** The term “District” shall mean the Southern Nevada Health District.
- 1.31 **“Domestic sewage” defined.** The liquid and waterborne wastes derived from the ordinary living processes, free from industrial wastes and of such character as to permit satisfactory disposal without special treatment into the public sewer or by means of an individual sewage disposal system.
- 1.32 **“Dosing tank” defined.** A watertight receptacle located between a septic tank and a disposal area equipped with an automatic siphon device or pumps designed to discharge sewage intermittently in the distribution lines in amounts proportioned to the capacity of such lines and provide adequate rest periods between such discharges.
- 1.33 **“Drip field” defined.** This is the disposal field for treated wastewater in subsurface drip disposal systems.
- 1.34 **“Effluent” defined.** This is a partially or completely treated sewage that flows out of a septic tank or an alternative treatment system
- 1.35 **“Facultative bacteria” defined.** Bacteria that have the ability to live under both aerobic and anaerobic conditions.
- 1.36 **“Fixture unit (FU)” defined.** A fixture unit (FU) is equal to one cubic foot (1 ft³) of wastewater per minute, equal to 7.5 gallons per minute. A fixture unit is not a flow rate unit but a design factor.
- 1.37 **“Geo-textile fabric” defined.** These are permeable fabrics which, when used in association with sand, have the ability to separate, filter, reinforce, protect, or drain.

- 1.38 **“Grinder pump” defined.** This is a macerating pump capable of grinding up sewage, including the solid waste, so that the waste product can be pumped at pressure to a treatment system. These can be found in basements where the waste is then lifted to the surface under pressure.
- 1.39 **“Health Authority” defined.** The Southern Nevada Health District Officer or his designee.
- 1.40 **“Holding tank” defined.** A watertight, covered receptacle that is designed and constructed to receive the discharge of sewage from a building sewer and temporarily store that sewage until the sewage is removed by a septic tank pumping contractor.
- 1.41 **“Individual sewage disposal system (ISDS)” defined.** A single system for the treatment and disposal of domestic sewage by means of septic tank and soil absorption system.
- 1.42 **“Inlet and Outlet tees” defined.** These are devices on the inlet and outlet ports of a septic tank. The sanitary tee pipe at the tank inlet slows the incoming rush of influent to prevent disturbance to the scum layer and reduce turbulence. The sanitary tee pipe located at the tank's outlet keeps solids, scum and grease from leaving the tank and entering the soil absorption system. These must be in place at the time of inspection by the Health Authority.
- 1.43 **“Impervious material” defined.** This is a material having a percolation rate greater than sixty (60) minutes per inch.
- 1.44 **“Influent” defined.** This is wastewater, partially or completely treated, or in its natural state, flowing into a septic tank, treatment unit, or disposal unit.
- 1.45 **“Leach field” defined.** This is a soil absorption system involved in the treatment of wastewater.
- 1.46 **“Lift pump” defined.** A lift pump is used to move liquid effluent from a lower pumping chamber or effluent tank to a higher level tank or possibly out of an effluent tank up to a soil absorption system.
- 1.47 **“Lot” defined.** A distinct parcel of land assigned its own Assessor’s Parcel Number (APN). The term does not include a parcel of land used or intended solely for use as a location for a water well.
- 1.48 **“Mound or Septic mound system” defined.** An effluent treatment disposal system composed of fill and a network of perforated pipes in which effluent treatment occurs within the filled bed. This is also called the Wisconsin Mound System.
- 1.49 **“Natural drainage channel” defined.** Canyons, swales or depressions upon and over which storm waters are sometimes transported. They may sometimes be, and generally are, dry.

- 1.50 **“Nitrogen removal system” defined.** A system that receives sewage, and through biological de-nitrification, chemical reduction or ion exchange, reduces the average total nitrogen concentration in the treated effluent to less than or equal to ten (10) milligrams per liter or parts per million.
- 1.51 **“Percolation rate” defined.** The relatively constant rate, calculated in minutes per inch, at which clear water maintained at a constant depth that seeps out of a standard-size test hole that has been previously saturated.
- 1.52 **“Percolation test” defined.** This is a procedure to measure the percolation rate.
- 1.53 **“Person” defined.** An individual, firm, partnership, association, corporation, company, governmental entity, club, or organization of any kind.
- 1.54 **“Pipe and gravel leach field” defined.** This is an absorption field utilizing perforated pipes and infiltration of wastewater over ½” to 2 ½” gravel.
- 1.55 **“Potable water” defined.** Water that is satisfactory for drinking, culinary and other domestic purposes and which meets the applicable requirements of the Health Authority relating to potable water.
- 1.56 **“Public health hazard” defined.** For the purpose of these Regulations, a condition whereby there are sufficient types and amounts of biological, chemical, or physical agents relating to wastewater or sewage which are likely to cause human illness, disorders, or disability. These include, but are not limited to, pathogenic viruses and bacteria, parasites, toxic chemicals and radioactive isotopes. A malfunctioning individual sewage disposal system constitutes a public health hazard.
- 1.57 **“Repair of ISDS” defined.** At the discretion of the Health Authority, the repair of an individual sewage disposal system is any action that allows for the unrestricted movement of effluent, which includes: the flushing and unplugging of solid pipes, installation and repair of inlet and outlet tees, and the removal and replacement of solid pipes only. Repairs include, without limitation: adding a distribution box, adding a riser for septic tank lid (s), septic tank lid replacements, centering connection to manifold (header line), adding an end cap to leach line(s), and the installation of aeration risers. Repair work does not require the issuance of an ISDS permit; however, an inspection by the Health Authority at the applicable fee may be required (see **Section 16**).
- 1.58 **“Retaining wall” defined.** A wall constructed to hold back at least three (3) corrugated masonry units (CMUs) high of soil or rock from a building, structure or area. Retaining walls prevent downslope movement or erosion and provide support for vertical or near-vertical grade changes.
- 1.59 **“Right-of-way” defined.** Includes all public and private rights-of-way and shall include all areas required for public use in accordance with any master plan or parts thereof.

- 1.60 **“Sand filter septic system” defined.** This is a wastewater treatment system in which the septic tank or aerobic unit effluent is intermittently spread across the surface of a bed of sand through a network of distribution lines.
- 1.61 **“Sand layer” defined.** This is a layer of sand at least two feet (2’) thick of fine or loamy sand with geo-textile fabric lining the bottom and sides, placed below a leach field when the soil percolation rate is less than one (1) minute per inch.
- 1.62 **“Scum” defined.** Also referred to as “FOG” – fats, oils, and grease. This is a mass of sewage solids floating on the surface of wastes in a septic tank which is buoyed up by entrained gas, grease, or other substances.
- 1.63 **“Seepage bed” defined.** A trench or bed not containing a minimum of twenty-four inches (24”) of clean, coarse aggregate and a system of distribution piping through which treated sewage may seep into the surrounding soil.
- 1.64 **“Seepage pit” defined.** An underground receptacle with manhole cover brought to the surface for observation and cleaning purposes to insure the disposal of septic tank effluent by soil absorption through its walls and bottom.
- 1.65 **“Septic system” defined.** See definition of **“Individual sewage disposal system (ISDS)”**
- 1.66 **“Septic tank” defined.** A watertight reservoir or tank which receives raw sewage, and by bacterial action and sedimentation, affects a process of clarification and decomposition of solids.
- 1.67 **“Septic tank pumping contractor” defined.** Any person engaged in the operation of removing and disposing of the solid and liquid contents of septic tanks, holding tanks or other sewage treatment or disposal facilities.
- 1.68 **“Shall” defined.** A mandatory requirement except when modified by action of the Health Authority on the basis of justifying facts submitted as part of plans and specifications for a specific installation.
- 1.69 **“Sequencing batch reactor” defined.** A sequencing recycling batch reactor, (SRBR®) is a form of an SBR that normally contains 2 or more tanks in series to help improve the quality of treatment and response to varying loading conditions usually encountered for small systems.
- 1.70 **“Sewage” defined.** The water-carried wastes created in and to be conducted away from residences, industrial establishments and public buildings.
- 1.71 **“Shallow absorption system” defined.** A leach field having a depth of fifty-four inches (54”) or less below final grade shall be termed a shallow absorption system.

- 1.72 **“Sludge” defined.** This is the accumulation of solids which have settled in a septic tank or a sewage holding tank.
- 1.73 **“Soil absorption system” defined.** Any system that utilizes the soil for subsequent absorption of treated sewage, such as an absorption trench, seepage bed or a seepage pit.
- 1.74 **“Soil permeability” defined.** This is the rate of wastewater movement through saturated soil in inches per hour.
- 1.75 **“Streets” defined.** Streets include avenues, boulevards, roads, lanes, alleys, viaducts, public easements and rights-of-ways.
- 1.76 **“Structure” defined.** A structure is something built or constructed. A structure is synonymous with a building and has columns that support a roof.
- 1.77 **“Subsurface drip disposal system (SDD)” defined.** This is a shallow, pressure-dosed, slow-rate, underground disposal system for treated wastewater, utilizing drip technology. It uses several hundred or thousand dosing points equally. Disposal of wastewater above the ground surface is prohibited.
- 1.78 **“Substantially compliant” defined.** At the discretion of the Health Authority, this is less than or equal to a 10% variation from the required measurement or area, excluding structure, property line, and drinking water well setback requirements.
- 1.79 **“Sweeping Tee” defined.** This is a tee fitting that allows direct flow in one direction by the use of an internal baffle. Sweeping Tees are prohibited.
- 1.80 **“System failure” defined.** Sewage effluent exceeds the infiltration capacity of the soil resulting in noxious odors, and ponding.
- 1.81 **“Tenant improvement” defined.** This is a revision to an ISDS permit issued by the Health Authority for the construction of a structure or the remodel of an existing structure prior to the issuance of a building permit.
- 1.82 **“Test hole” defined.** A test hole is ground penetration for the purpose of geotechnical, geophysical or geologic investigation. For the purpose of these Regulations, it is used to determine the depth of groundwater. There must be a five feet (5’) minimum vertical separation between the groundwater table and the bottom of the soil absorption system.
- 1.83 **“Total nitrogen (TN)” defined.** The total nitrogen in wastewater is comprised of dissolved inorganic and organic nitrogen and particulate organic and inorganic nitrogen, minus nitrogen gas.
- 1.84 **“Total Suspended Solids (TSS)” defined.** These are particles that are not dissolved in solution.

- 1.85 **“Tree” defined.** A tree is a plant having a main stem or trunk, including palm trees.
- 1.86 **“Vapor barrier” defined.** This is a one foot wide trench to the depth of the leach field, lined with 10 mL or greater of visqueen and filled with utility sand.
- 1.87 **“Wastewater” defined.** See definition of **“Sewage”**
- 1.88 **“Watercourse” defined.** Any channel through which water flows, or any stream of water such as a river, a brook or an underground stream. The term does not include intermittent natural streams or washes which have no lasting effect on the bacteriological process in the soil which could change the process from predominantly aerobic to predominantly anaerobic.
- 1.89 **“Waters of the state” defined.** Per NRS 445A.415, these are all waters situated wholly or partly within or bordering upon this State, including but not limited to: all streams, lakes, ponds, impounding reservoirs, marshes, watercourses, water ways, wells, springs, irrigation systems and drainage systems; and all bodies or accumulations of water, surface and underground natural or artificial.
- 1.90 **“Water softener” defined.** Water softeners remove unwanted minerals from the water supply using one of several methods such as ion exchange, producing a brine waste stream. The Health Authority does not recommend the discharge of water softener backwash brine into the septic system.
- 1.91 **“Water table” defined.** This is the level in saturated soil at which the hydraulic pressure is zero.
- 1.92 **“Waterproof” defined.** Coated with a material to prevent permeation by water.

Section 2

PERMISSION TO CONSTRUCT – PERMIT APPLICATIONS

- 2.1 In cities, political subdivisions and in all unincorporated areas within the District's boundaries, prior permission to construct, alter or extend an ISDS shall be obtained from the District. This permission shall be required before any building permit or certificate of occupancy can be issued for any structure to be served by an individual sewage disposal system.
- 2.2 **Residential ISDS Permit.** The Health Authority may require additional information on a case-by-case basis to fulfill the requirements for all septic system permit applications. The septic system permit application shall include the following:
 - 2.2.1 An application to the Health Authority constitutes the submittal of **all** of the requirements for the permit sought. This includes, without limitation: a plot plan, with the north directional arrow, drawn to an engineer or architect's scale including the dimensions of lot lines, land area available, applicable street names, easements, driveway, and topography. The plot plan shall also locate the proposed individual sewage disposal system with reference to distances of separation from water supply line(s), water meter, watercourse, wash, flood control way, fire hydrant(s), well(s), building(s), structure(s), retaining wall(s), block wall(s), tree(s), proposed swimming pool, spa, pool equipment and property lines. The plot plan must include the distance to the nearest sewer line, if the community is served by public sewer.
 - 2.2.2 The submittal shall include soil characteristics, depth to water table or bedrock, if soil percolation rate submitted is lower than the standard used which is fifteen minutes per inch (15 min/inch), and plumbing fixture units.
 - 2.2.3 The submittal shall include the recorded deed for the property and a full-sized parcel map or subdivision map as recorded with the Clark County Recorder's Office.
 - 2.2.4 The application shall not be processed without proof of an approved water source, which includes, without limitation, a letter from a municipal water agency (if not served by the Las Vegas Valley Water District) stating that the property will be served with water, or a well driller's report and approval by the Nevada Division of Water Resources.
 - 2.2.5 The application shall not be processed without an inquiry response from the municipal sewer agency within jurisdiction of the property or from the Public Works Department setting forth whether the property fits the criteria to connect the public system.

- 2.2.6 Additional information may be required by the Health Authority and will be determined on an individual basis.
- 2.2.7 If the information and data submitted above do not meet the requirements of these Regulations, the application to construct shall be denied.

2.3 **Commercial ISDS Permit.** The issuance of a commercial ISDS permit from SNHD shall be in conformance with the most current Memorandum of Agreement signed with the Nevada Division of Environmental Protection (NDEP). The application for the installation of a sewage disposal system for a commercial facility shall include two (2) percolation tests consisting of two (2) test holes and one (1) soil boring, as described in **Section 15**, all items in **Section 2.2**, inclusive, with all design computations for review by the Health Authority, along with the following additional commercial ISDS application requirements:

- 2.3.1 For food establishments, childcare facilities and any other facility requiring Plan Reviews from other Health District sections, the floor plan(s) must first be approved by the District's Plan Review Section, prior to submission for a commercial ISDS permit. Floor plans submitted should be signed and dated by the assigned Plan Review person.
- 2.3.2 The plot plan, showing finished grade contour elevations, must be signed and sealed by a State of Nevada registered professional engineer.
- 2.3.3 The plot plan must include invert elevations for all plumbing relating to the septic system.
- 2.3.4 The plot plan must include a permanent barrier to prevent vehicular access and/or traffic over the septic system. If a traffic-rated septic tank is proposed, the septic tank detail must be submitted.
- 2.3.5 Parking lots must be shown, along with bumpers (if applicable).
- 2.3.6 The mechanical plumbing plans for condensate waste lines / evaporative cooler overflow lines must drain indirectly to the septic system through a sand/oil or similar interceptor. If a closed air conditioning (AC) unit is proposed, with no condensate to be drained, then a note to that effect must be included on the mechanical plumbing plan that is signed and sealed by the engineer.

- 2.3.7 A statement either on the plot plan or on letterhead, signed and sealed by a State of Nevada registered professional engineer regarding the relationship of the property to the 50-year flood plain.
- 2.3.8 Each commercial building with plumbing requires its own septic system.
- 2.3.9 Commercial ISDS permits will be approved for the treatment of human waste only. No chemical waste shall be allowed to enter the ISDS. Any transfer of a property with a commercial ISDS must have the approval of the Health Authority for continued use.
- 2.3.10 A commercial water supply well per the Nevada Division of Water Resources is required for all commercial ISDS permits.

2.4 **Commercial Holding Tank Permit.** The issuance of a commercial holding tank permit from SNHD shall be in conformance with the most current Memorandum of Agreement signed with the Nevada Division of Environmental Protection (NDEP). A commercial holding tank permit shall only be installed on non-residential properties on a temporary basis. The maximum length of time for a commercial holding tank permit shall be twelve (12) months from the date of issuance. The application requirements for commercial holding tanks shall include:

- 2.4.1 The legal description of the property, tax assessor's parcel number (APN), recorded deed, and a map of the site with a north directional arrow indicating the nearest street intersection.
- 2.4.2 A plot plan, signed and sealed by a State of Nevada registered professional engineer, drawn to an engineer or architect's scale showing the proposed location of the holding tank (along with the tank capacity), modular/trailer or temporary structure, water meter, water lines (s), sewer line (s) with invert elevations, and parking area.
- 2.4.3 A floor plan showing all plumbing fixtures.
- 2.4.4 A letter from the applicant requesting the permit, including the following: the location of the property, reason for the request, time frame anticipated (12 months maximum).
- 2.4.5 An inquiry response from the municipal sewer agency within the jurisdiction of the property or from the Public Works Department setting forth whether the property fits the criteria to connect to the public system.
- 2.4.6 A copy of a contract with a Health Authority approved liquid waste hauler.

- 2.4.7 A copy of a water meter receipt or a water service application acknowledgement from the water utility within the jurisdiction of the property. If the property will be served by a well, a copy of the well driller's log including the Nevada Division of Water Resources permit number is required. The water supply from the well must be approved by the Nevada Division of Water Resources for the commercial holding tank permit. Water connection to the modular/trailer or temporary structure must be completed prior to inspection from Health Authority.
- 2.4.8 Inspection of the commercial holding tank shall be according to the inspection requirements in **Section 16** of these Regulations.
- 2.4.9 **Commercial Re-submittal Fee.** If all items are not submitted to the Health Authority for the processing of a commercial ISDS or commercial holding tank permit **or** if revisions are necessary, a re-submittal fee as referenced by the current SNHD Environmental Health Permit Fee Schedule as it applies to individual sewage disposal systems shall be applicable. The re-submittal fee must be paid and the corrective actions addressed prior to the issuance of the permit.
- 2.5 **ISDS Permit Fee.** Pursuant to NRS 439.360(5) and NRS 439.366(1), the Board adopts by reference the current SNHD Environmental Health Permit Fee Schedule as it applies to individual sewage disposal systems (ISDS). The permit fee must be paid at the time of application to the Health Authority. All permit fees are non-refundable.
- 2.6 An individual sewage disposal system permit issued under these Regulations shall be considered as a temporary permit to operate the ISDS. The operating permit shall be valid until the disposal system fails; or a community sewerage system is installed to service the area and connection hereto is legally required.
- 2.7 Permission to construct shall be denied if:
- 2.7.1 The Health Authority determines that the proposed installation will not comply with these Regulations; or
- 2.7.2 A public or community sewerage system is available within four hundred feet (400') of the nearest property line and can be accessed by a gravity flow line, and is accessible per the sewer authority of jurisdiction.
- 2.8 Where the natural soil condition has been altered by filling or other attempts to improve wet areas, verification may require observations of high groundwater levels under saturated soil conditions.
- 2.9 Permits shall be null and void after twelve (12) months from the date of issuance, if the proposed construction, alteration or extension of the sewage disposal system

is not started within this time. A **one time** ninety (90) day extension of time may be requested in writing by the ISDS permit holder **before** the permit expiration date, including without limitation, the ISDS permit number, the active building permit number, and the signature of the permittee.

- 2.10 At the discretion of the Health Authority, the ISDS may be required to be installed by a State of Nevada licensed contractor.

Section 3

TENANT IMPROVEMENT APPLICATIONS

- 3.1 A Tenant Improvement Application is required for the construction of a new structure with or without plumbing or the remodel of an existing structure, prior to the issuance of a building permit or certificate of occupancy from the Building Department of the local jurisdiction.
- 3.2 The Tenant Improvement Application constitutes the submittal of all of the requirements for processing to the Health Authority.
- 3.3 A plot plan shall be submitted in accordance with **Section 2.2** inclusive for residential and **Section 2.3** inclusive for commercial, for the processing of all tenant improvement approval requests.
- 3.4 Any plumbing additions to parcels being served by a community well (quasi-municipal well) shall require the approval of the Nevada Division of Water Resources prior to approval from the Health Authority.
- 3.5 Any Tenant Improvements with additional plumbing will require a septic system installed according to these Regulations, which may require a new ISDS Residential Permit or repairs to an existing ISDS.
- 3.6 **Tenant Improvement Processing Fee.** Pursuant to NRS 439.360(5) and NRS 439.366(1), the Board adopts by reference the current SNHD Environmental Health Permit Fee Schedule as it applies to individual sewage disposal systems (ISDS). The tenant improvement processing fee must be paid at the time of application. All fees shall be non-refundable. At the discretion of the Health Authority, an inspection based on the current Environmental Health Fee Schedule to verify the location of the ISDS, verify repairs or to verify compliance with these Regulations.
- 3.7 The Tenant Improvement approval request shall be denied if the existing individual sewage disposal system (ISDS) is in violation of any of these Regulations.
- 3.8 Detached corner buildings with plumbing will not be approved as Tenant Improvements. A separate commercial ISDS permit will be required.
- 3.9 Tenant Improvements will not be approved for properties without a Health Authority approved ISDS permit.
- 3.10 In lieu of building plans showing plumbing fixtures, a letter signed by a State of Nevada licensed plumber, including licensed number, will be acceptable. The letter must detail the number of individual plumbing fixtures, and specify how many toilets are low-flow (1.6 gallons per flush).

Section 4

CERTIFICATION OF INDIVIDUAL SEWAGE DISPOSAL SYSTEMS (ISDS)

- 4.1 The Health Authority shall be the sole entity within its jurisdiction that provides official certification for permitted individual sewage disposal systems.
- 4.2 The Health Authority shall only provide certification of permitted individual sewage disposal systems (ISDS) in compliance with these Regulations, and water wells logged with the Nevada Division of Water Resources.
- 4.3 The certification of an ISDS and/or water well shall be valid for one (1) year after issuance provided that no changes are made to the property. Certifications shall be null and void if any changes are made to the property, septic system, or water supply.
- 4.4 **ISDS Certification Fee.** Pursuant to NRS 439.360(5) and NRS 439.366(1), the Board adopts by reference the current SNHD Environmental Health Permit Fee Schedule as it applies to individual sewage disposal systems (ISDS). The ISDS certification fee must be paid to the Health Authority prior to scheduling an inspection. The ISDS certification fee shall be non-refundable.
- 4.5 The ISDS certification procedure includes the following requirements:
 - 4.5.1 If the final ISDS construction approval occurred within the last three (3) months to date when the certification is requested, a file search fee, according to the current SNHD Environmental Health Fee Schedule, shall be required for the ISDS certification and an onsite inspection will not be required.
 - 4.5.2 If the final construction approval occurred within twelve (12) months to the date when the certification is requested, an onsite inspection of the property is required and the septic tank lid does not have to be removed.
 - 4.5.3 If the final ISDS construction approval is over twelve (12) months to the date when the certification is requested, the septic tank lid must be removed for inspection, that is, first compartment of the septic tank that connects directly to the sewer line from the building. However, if a pumping receipt is submitted to the Health Authority from an approved liquid waste hauler dated within twelve (12) months to the date the certification is requested, then the septic tank lid does **not** have to be removed for inspection.
 - 4.5.4 The Health Authority may request additional information to complete the ISDS certification process.
 - 4.5.5 If the certification is not approved, the re-inspection fee shall be assessed according to the current SNHD Environmental Health Fee Schedule. The re-inspection fee must be paid prior to scheduling another inspection.

- 4.5.6 If plumbing additions have been made to the property without Health Authority approval, a Tenant Improvement must be approved before any certification is issued.
- 4.6 The water well certification procedure includes the following requirements:
 - 4.6.1 A copy of the well driller's log approved by the Nevada Division of Water Resources is required, if a copy is not on file with the Health Authority.
 - 4.6.2 The certification fee shall be paid prior to scheduling the inspection of the water well. The certification fee shall be non-refundable.
 - 4.6.3 The Health Authority shall have full access to the well and pump for inspection purposes.
 - 4.6.4 A chemical and bacteriological analysis shall be required for the certification of the well water. This may be done through a private laboratory certified by the State of Nevada. The original test results must be submitted to the Health Authority for review before the certification of the well can be processed.
 - 4.6.5 The water sample tested must meet all the EPA and State of Nevada Safe Drinking Water Standards in order for the well to be certified.
 - 4.6.6 If the certification is not approved, the re-inspection fee shall be according to the current SNHD Environmental Health Fee Schedule. The re-inspection fee must be paid prior to scheduling another inspection.
 - 4.6.7 The Health Authority may request additional information to complete the water well certification process.

Section 5

LOCATION OF INDIVIDUAL SEWAGE DISPOSAL SYSTEMS

- 5.1 No septic tank or soil absorption system shall be located within ten feet (10') of any property line or tree, or shall trees be planted within ten (10') of a soil absorption system or septic tank.
- 5.2 The horizontal separation from a shallow absorption system to the foundation of a building or structure shall be at least eight feet (8'), and twenty feet (20') from a deep absorption system, unless a Cone of Influence Letter is submitted by State of Nevada registered professional engineer.
- 5.3 Septic tank and shallow absorption system located within one hundred feet (100') nor shall a deep absorption system be located within one hundred and fifty feet (150') of any well.
- 5.4 See TABLE I for other separation requirements

TABLE I

Minimum Horizontal Separation Distance from:	Building Sewer Drain	Septic Tank	Shallow Soil Absorption System	Deep Absorption System
Building or Structure	3 ft	8 ft	8 ft	20 ft
Block Wall	3 ft	3 ft	3ft	3 ft
Retaining Wall	3 ft	8 ft	8 ft	20 ft
Property Line	10 ft	10 ft	10 ft	10 ft
Water Supply – Wells	50 ft	100 ft	100 ft	150 ft
Streams or Watercourses	50 ft	100 ft	100 ft	150 ft
Soil Disposal Systems	--	5 ft	5 ft	5 ft
Community Water Main Lines	10 ft	10 ft	25 ft	25 ft
Individual Water Service Lines	6 ft	10 ft	25 ft	25 ft
Swimming Pool and Spa Water Lines and Equipment	3 ft	10 ft	25 ft	25 ft

Section 6

SPECIFICATIONS FOR SEPTIC TANKS

- 6.1 Septic tanks shall have a minimum of two (2) compartments. The inlet compartment of any septic tank shall be not less than two-thirds (2/3) of the total capacity of the tank. See Figures 2 and 2A. When the septic is to be used for a de-nitrification system, the inlet compartment may be one-third (1/3) the total capacity of the tank if approved by the Health Authority.
- 6.2 All septic tanks, along with their manufacturers, must be approved by the Health Authority prior to installation. An approved septic tank manufacturer list may be requested from the Health Authority.
- 6.3 **Septic Tank Construction.** Septic tanks shall be watertight below the cover and shall be built so as to constitute a separate structure. They shall be constructed of materials resistant to decay, such as pre-cast concrete, and polyethylene. Other materials, equal in structural capability of withstanding all anticipated earth or other loads, may be approved by the Health Authority through a product review process.
- 6.3.1 Pre-cast concrete tanks shall have a minimum wall, floor and roof thickness of three inches (3"). The concrete shall have a minimum compressive strength of three thousand pounds per square inch (3,000 psi). The concrete shall be produced in accordance with the practices outlined in the American Concrete Institute Standards 301 and 318. Precast sections shall be set evenly in a full bed of sealing mortar or equivalent. Excessively mortared joints shall be sealed with bituminous sealing compound.
- 6.4 Type 5, sulfate resistant cement shall be used for all concrete mixes.
- 6.5 Each tank shall be clearly marked to show capacity, name and address of the registered trademark of the manufacturer.
- 6.6 Backfilling, after inspection and approval from the Health Authority, shall be carefully done to prevent damage to the septic tank. Before backfilling, each septic tank shall be adequately supported and may be required to be filled with water 24 hours prior to inspection to determine that it is watertight. The septic tank shall be level after setting.
- 6.7 All pre-fabricated tanks shall be watertight.
- 6.8 Septic tank capacity and design. The liquid capacity of a septic tank shall be determined by the number of persons using the building to be served or upon the nature of use and type of waste as determined from Table III, whichever is greater. The minimum liquid capacity of a septic tank measured below the outlet

shall be one thousand (1,000) gallons for any installation. The liquid depth shall not be less than thirty inches (30") or more than five feet (5'). The air space shall be at least nine inches (9") or 20% of the liquid depth.

6.9 **Septic Tank Dimensions:**

- 6.9.1 Rectangular septic tanks shall have a minimum width of thirty inches (30") and shall be constructed with the longest dimensions parallel to the direction of flow.
- 6.9.2 When increased capacity is to be provided by using a number of prefabricated tanks, the minimum capacity of any unit shall be one thousand (1,000) gallons.
- 6.9.3 When two (2) or more tanks are installed in series, the baffle for the first tank is removed. The volume first tank will contribute to the second tank's first compartment. The combination of the first tank capacity and the volume first compartment for the second tank must equal $\frac{2}{3}$ the septic tank waste.

6.10 **Estimated Waste / Sewage Flow Rates; Recommended Design Criteria; Quantity of Sewage Flow per Fixture; Septic Tank Capacities** (see TABLE II, TABLE III, and TABLE IV, respectively).

TABLE II
ESTIMATED WASTE / SEWAGE FLOW RATES

Type of Occupancy	Unit Gallons Per Day
Airports	15 per employee 5 per passenger
Auto washers	Check with equipment manufacturer
Bowling alleys (snack bar only)	75 per lane
Camps: Campground with central comfort station Campground with flush toilets, no showers Day Camps (no meals served) Summer and Seasonal	35 per person 35 per person 15 per person 50 per person
Churches (Sanctuary) with kitchen waste	5 per seat 7 per seat
Dance Halls	5 per person
Factories No showers With showers Cafeteria, add	25 per person 35 per employee 5 per employee
Hospitals Kitchen waste only Laundry waste only	250 per bed 25 per bed 40 per bed
Hotels (no kitchen waste)	60 per bed (2 person)
Institutions (Resident) Nursing Home Rest Home	75 per person 125 per person 125 per person
Laundries , self-service (minimum 10 hours per day)	50 per wash cycle Per manufacturer's specifications
Motel With Kitchen	50 per bed space 60 per bed space

Offices	20 per employee
Golf Course [(18 holes x # of shifts x 4 people per round)] / 2 x 10 gallons per day per golfer * note that one shift = 8 hrs	10 per golfer
Restaurants – Cafeterias Toilet Kitchen waste Add for garbage disposal Add for cocktail lounge Kitchen waste – disposal service	20 per employee 7 per employee 6 per meal 1 per meal 2 per customer 2 per meal
Schools – Staff and Office Elementary students Intermediate and high with gym and showers, add with cafeteria, add Boarding, total waste	20 per person 15 per person 20 per person 5 per student 3 per student 100 per person
Service Station, toilets	1000 for 1 st bay 500 for each and additional bay
Stores Public restrooms, add	20 per employee 0.1 per square feet of floor space
Swimming Pools, public	10 per person
Theaters, Auditoriums Drive-In	5 per seat 10 per person

RECOMMENDED DESIGN CRITERIA. Sewage disposal systems sized using the estimated waste/sewage flow rates should be calculated as follows:

- 1) Waste/sewage flow, up to 1,500 gallons/day
Flow x 1.5 = septic tank size
- 2) Waste/sewage flow, over 1,500 gallons/day
Flow x 0.75 + 1125 = septic tank size
- 3) Secondary system shall be sized for total flow per 24 hours

TABLE III

Quantity of Sewage Flow per Fixture

Kind of Fixture	Private Use	Public Use
Bar Sink	1	2
Bathtubs (with or without shower over)	2	4
Bidets	2	2
Dental units or cuspidors		1
Drinking Fountains (each head)	1	2
Floor Drains	2	2
Interceptors for grease, oil, solids, etc	3	3
Interceptors of sand, auto wash, etc		6
Laundry tubs	1	2
Clothes washers	2	4
Receptors (floor sinks) indirect waste receptors for refrigerators, coffee urns, water stations, etc	1	1
Receptors indirect waste receptors for commercial sinks, dishwashers, air washers		3
Showers (each head)	2	4
Sinks, commercial or industrial, schools, etc (including dishwashers, wash-up sinks, and wash fountains, 2" min waste)		4
Sinks, flushing rim, clinic		10
Sinks, and/or dishwashers (residential, 2" min waste)	2	
Sinks, service	3	3
Trailer Park Traps (one for each trailer)	6	6
Urinals, pedestal	2	10
Urinals, stall	2	5
Urinals, wall (2" min waste)	2	5
Wash basins (lavatories) single	1	1
Wash basins (lavatories) double	2	2
Water closets (flush tanks)	4	5
Low water consumption water closet	2*	
Water closets (flushometer valve)	6	10

*NOTE: The total fixture count on existing permits may be reduced for low water consumption fixtures. Reductions will be determined by the Health Authority on a case-by-case basis, depending on the type of fixture to be used and the nature of the use.

TABLE IV
SEPTIC TANK CAPACITIES

Maximum Fixture Units Served	Minimum Septic Tank Capacity in Gallons
20	1000
25	1200
35	1500
45	2000
55	2250
60	2500
70	2750
80	3000
90	3250
100	3500
<p>Fixture units over 100 – 25 gallons per fixture unit.</p> <p>NOTE: Septic tank sizes in this table include sludge storage capacity and the connection of domestic food waste disposal units and dishwashers without further volume increase.</p>	

6.11 **Inlets and Outlets Tees; Baffles**

- 6.11.1 The inlet and outlet of septic tanks or tank compartments shall be provided with open-end schedule forty (40) polyvinyl chloride (PVC) sanitary tees or equivalent or baffles made of approved materials, so constructed as to distribute flow and retain scum in tank or compartments. The tees or baffles shall extend at least six inches (6") above the liquid level. The inlet device shall penetrate at least six inches (6") but not more than the outlet device. The outlet tee or baffle shall extend to a distance below the surface equal to forty percent (40%) of the liquid depth, and thirty-six percent (36%) for horizontal cylindrical tanks. The inlet and the outlet arrangements shall provide for free flow of air between inlet and outlet. At least two inches (2") of clear space shall be provided over the top baffle or tees. The invert of the outlet pipe shall be at least three inches (3") lower than the invert of the inlet pipe.
- 6.11.2 The inlet and outlet pipes between a septic tank and firm ground beyond the excavation made to install the tank shall be schedule forty (40) PVC or other pipe approved by the District for this specific purpose. The joint between the pipe and tank shall be made watertight.
- 6.11.3 The inlet and outlet openings of all tanks shall contain a "boss," stop or other provision to which will prevent the insertion of the sewer piping beyond the inside tank wall facing.

6.12 **Manholes**

Access to each septic tank shall be provided by at least two (2) manholes, with a minimum dimension of twenty inches (20") square or twenty inches (20") in diameter at the top. Manholes shall extend to within at least twelve inches (12") of the ground surface and provided with substantial concrete, steel, stone, fiberglass or cast iron covers. On steel tanks, the collar for manhole extensions shall be at least two inches (2") high.

Section 7

MAINTENANCE AND SLUDGE DISPOSAL

- 7.1 Septic tanks shall be cleaned whenever the sludge and scum occupies one-third (1/3) of the tank volume.
- 7.2 Sludge and scum from septic tanks and any other material removed from a sewage disposal unit, all hereafter referred to as sludge, shall be pumped by a liquid waste hauler approved by the Health Authority and disposed of at an approved disposal facility in such a manner as not to create a nuisance or menace to public health. Unless otherwise authorized by the Health Authority, the sludge shall be disposed of as follows:
 - 7.2.1 By discharge into a public sewerage system when practical. The point and method of discharge into the system shall be subject to the requirements of the municipality.
 - 7.2.2 By discharge at a disposal site designated by a city or political subdivision for such purpose.
- 7.3 Sludge shall not be disposed of by discharge into a lake, stream, ditch or dry run or be deposited within one hundred feet (100') of such watercourses.

Section 8

DISTRIBUTION BOX

- 8.1 A distribution box shall be used for all systems (commercial and residential) greater than two thousand (2,000) gallons or a system utilizing an odd number of chamber rows, leach lines or trenches. Distribution boxes shall also be used when split soil absorption systems are installed.
- 8.2 Each distribution line or chamber row shall be connected separately to the distribution box. The outlet lines shall be set at the same level and four inches to six inches (4" to 6") above the bottom of the box. The inlet shall be at least one inch (1") above the outlet.
- 8.3 The size of the distribution box shall be sufficient to accommodate the required number of distribution lines. The box shall be of watertight construction.
- 8.4 The distribution box shall be installed on cast-in-place or on a pre-cast concrete pad that extends three inches (3") beyond its edge, or on compacted soil. The distribution box must be level and steady. Precautions must be taken during backfilling, after inspection and approval from the Health Authority, to prevent shifting of the distribution box.

Section 9

EFFLUENT DISPOSAL

- 9.1 **Location and Method.** The effluent from septic tanks shall be disposed of by a soil absorption system or by some other manner approved by the Health Authority provided such disposal does not create a nuisance or hazard to public health.
- 9.1.1 All soil absorption disposal units should be located at a point lower than the grade of any nearby water well, unless permission is obtained from the Health Authority.
- 9.1.2 The horizontal separation from a shallow absorption system to the foundation of a building or structure shall be at least eight feet (8'), and twenty feet (20') from a deep absorption system.
- 9.1.3 Effluent disposal fields shall not be located within one hundred feet (100') nor shall a deep absorption system be located within one hundred and fifty feet (150') of any well or watercourse.
- 9.1.4 Wells should be above the elevation of the septic system, as determined from the contour elevations.
- 9.1.5 Effluent disposal systems shall not be permitted in areas subject to flooding.
- 9.1.6 The size of the soil absorption system to be used for effluent disposal shall be determined through percolation tests made in accordance with **Section 15** of these Regulations.
- 9.2 **Pipe and Gravel Leach Fields.** The following design and construction procedures providing for gravel fill, and adequate distribution system and protection of the absorption area shall be observed (See Figure 4):
- 9.2.1 The bed shall have a minimum depth of thirty-six inches (36") below natural ground level to provide minimum earth backfill of twelve inches (12").
- 9.2.2 The bed should have a minimum of twenty-four inches (24") of gravel. The piping shall be laid on a minimum of eighteen inches (18") of gravel and shall be surrounded by the aggregate which shall extend at least two inches (2") above the top of the pipe.
- 9.2.3 The bottom of the bed and distribution pipe or perforated pipe shall be level or two inches per hundred feet (2"/100') maximum slope.

- 9.2.4 Lines for distributing effluent shall be spaced a minimum of six feet (6') apart and a minimum of three feet (3') from bed sidewall. The maximum length of lines distributing effluent shall be one hundred (100') feet.
- 9.2.5 Only straight tees are allowed for distribution piping in the leach field. Sanitary, sweeping and directional tees are prohibited.
- 9.2.6 Clean graded rock, gravel or similar aggregate ranging in size from one-half inch (1/2") to two and one-half inches (2-1/2") shall be laid in the bed.
- 9.2.7 Distribution piping shall be perforated. The holes of the perforated pipe shall be pointed downwards.
- 9.2.8 The top of the aggregate shall be covered with untreated building paper or a two inch (2") layer of hay or straw to prevent the stone from becoming clogged by the earth backfill.
- 9.2.9 If the backfill cover over the aggregate exceeds three feet (3'), then aeration risers will be required (See Figure 11). If the horizontal separation of the deep absorption field is within twenty feet (20') or a shallow absorption field is within eight (8) feet of the foundation of a structure, building or retaining wall, a Cone of Influence Letter will be required.

9.3 **Chamber System Leach Fields.** Chamber system leach fields shall be gravel less. Leaching chambers allow for more of the soil profile to be used since the septic tank effluent is distributed to the ground below and the soil surrounding the chamber. Hence, the disposal area shall be thirty percent (30%) less than the area required for pipe and gravel disposal fields. All leaching chambers, along with their manufacturers, must be approved by the Health Authority prior to their installation. A list of approved leaching chambers and their manufacturers may be requested from the Health Authority.

- 9.3.1 The excavation in which leaching chambers are placed shall be level.
- 9.3.2 Leaching chambers shall be installed and connected based on the manufacturer's installation guidelines. This includes, without limitation, the feeder line connections and end caps.
- 9.3.3 Leaching chambers from different manufacturers shall not be used in combination.
- 9.3.4 The distribution header line or manifold shall be level and made of solid PVC piping, or other piping approved by the Health Authority.
- 9.3.5 The effluent line from the septic tank shall bisect the distribution header line or manifold in the middle, except when utilizing a distribution box. A chamber

system utilizing a distribution box must have outlet pipes from the distribution box connected directly to each chamber row.

- 9.3.6 Leaching chamber rows shall be equal in length and shall not exceed one hundred (100') feet. A distribution box shall be required for any configuration utilizing an odd number of chamber rows.
 - 9.3.7 If more than one leaching chamber field is being installed, each field shall have an equal number of leaching chambers with a distribution box splitting the effluent flow between the fields. There shall be a minimum of five (5') feet separation between the leach fields.
 - 9.3.8 There shall be no lateral spacing between individual chamber rows.
 - 9.3.9 There shall be a minimum of one foot (1') of native backfill cover over of the leaching chambers.
 - 9.3.10 If the backfill cover over the leaching chambers exceeds three feet (3'), then aeration risers shall be required (See Figure 11). If the horizontal separation of the deep absorption field is within twenty feet (20') or eight (8') feet for a shallow absorption field **or** within eight (8') feet of the foundation of a structure, building or retaining wall, a Cone of Influence Letter shall be required.
- 9.4 **Seepage Pits.** Seepage pits should be used when deeper soil formations are more porous than the upper soil. The seepage pits shall consist of a chamber, walled up with materials which allow water to percolate through it, such as a joint brick, concrete block, dry rubble or an approved equal. (See Figure 6)
- 9.4.1 The seepage pit must be designed by a State of Nevada registered professional engineer.
 - 9.4.2 The capacity of the seepage pit shall be computed on the basis of percolation tests made in each vertical stratum penetrated. No allowance shall be made for impervious strata or bottom area.
 - 9.4.3 The seepage pit bottom shall be left open to the soil.
 - 9.4.4 Pits shall be backfilled with clean ½" to 2 ½" gravel to a depth of one foot (1') above the pit bottom.
 - 9.4.5 The diameter of a pit shall not be less than five feet (5').
 - 9.4.6 The annular space between the outside of the lining and the pit wall shall be a minimum of twelve inches (12").

- 9.4.7 The annular space shall be filled with coarse aggregate, one half inch (1/2") to one inch (1") in size to the top of the pit.
- 9.4.8 Seepage pits shall not extend into creviced rock formation and shall terminate at least five feet (5') above the maximum seasonal water table.
- 9.4.9 Each seepage pit shall be provided with a watertight cover equipped with a manhole and fresh air inlet.
- 9.4.10 The seepage pit shall not be deeper than its width.

9.5 **Subsurface Drip Disposal Systems (SDD).** This system uses small diameter (usually 1/2") piping with underground emitters, which are preceded by a treatment system, approved by the Health Authority that conforms to the manufacturer's specifications for that system. Subsurface drip disposal systems are often used for sites with adverse conditions such as insufficient depth to a restrictive horizon, groundwater, and steep slopes.

- 9.5.1 The effluent shall be adequately filtered before distribution through the underground emitter system.
- 9.5.2 All subsurface drip disposal systems shall be designed and all plans submitted, signed and sealed by a State of Nevada registered professional engineer.
- 9.5.3 A contract with a Health Authority approved maintenance provider is required for the life of all subsurface drip disposal systems.
- 9.5.4 The subsurface drip disposal system shall be installed and maintained by the manufacturer or his designee.
- 9.5.5 To insure equal dosing of the drip disposal field, there shall be no more than a ten percent (10%) variation in the flow between any two emitters in the entire drip disposal field.
- 9.5.6 The primary treatment facility and dosing chamber shall be designed, constructed and installed to insure that all joints, seams, and component parts shall preclude infiltration of groundwater and the release of wastewater or liquids.
- 9.5.7 All electrical equipment shall be protected with safety devices (ground fault circuit interrupters, fuses, etc). All electrical equipment shall comply with appropriate National Electrical Manufacturer's Association (NEMA) requirements. Electrical components shall be covered by a manufacturer's limited warranty.

- 9.5.8 Valves, fittings and level control switches and all other components shall be designed and manufactured to resist the corrosive effects of wastewater and common household chemicals.
- 9.5.9 Prior to the design of the subsurface drip disposal system, the suitability of the site must be demonstrated through acceptable soil percolation tests and other topographical characteristics. The design and construction of the surface drip disposal system shall conform to the manufacturer's specification and to all criteria outlined in these Regulations.
- 9.5.10 Dosing Tanks for Subsurface Drip Disposal Systems.
- 9.5.10.1 The dosing tank shall have grade level access large enough to allow servicing and/or removal of the largest component in the chamber. All access ports shall be protected against unauthorized entrance or removal.
- 9.5.10.2 The dosing tank shall be made of material that is watertight, resistant to the corrosive effects of wastewater, and designed to withstand the lateral and bearing loads to which it is expected to be subjected.
- 9.5.11 Minimum Pump Specifications for Subsurface Drip Disposal Systems.
- 9.5.11.1 Only timed dosing subsurface drip disposal systems shall be permitted.
- 9.5.11.2 The pumping system shall be capable of dosing the drip field a minimum of six (6) equally spaced doses per twenty-four hour (24 hour) period. Each dose volume shall not exceed the estimated maximum daily flow divided by the number of dosing cycles.
- 9.5.11.3 The pump system shall be designed to discharge the required volume of wastewater within the pressure range specified by the tubing manufacturer.
- 9.5.11.4 The pump shall be equipped with a low water cutoff to prevent damage to pump during low water conditions in the dosing chamber.
- 9.5.11.5 The pump shall be constructed with corrosive resistant materials suitable for effluent pumping.

9.5.11.6 The pump shall be sized based on the manufacturer's specifications to meet or exceed the hydraulic requirement of the system. The pump shall also be installed in compliance with manufacturer's specifications so as not to violate the pump warranty.

9.5.11.7 The suction pressure lines shall be PVC schedule 40 or equal and sized to meet or exceed the hydraulic requirements of the system.

9.5.12 Minimum Filter Requirements for Subsurface Drip Disposal Systems.

9.5.12.1 The effluent shall be filtered to the specifications of the drip disposal manufacturer to prevent clogging of the emitters.

9.5.12.2 The filter shall achieve the required filtration rate at a rate equal to or greater than the peak discharge rate, including filter and/or system backwash, from either the treatment facility or pump, where applicable.

9.5.12.3 The filter shall be made of material resistant to the corrosive effects of wastewater and common household chemicals.

9.5.12.4 The filters shall be readily accessible for inspection and/or service.

9.5.12.5 The filter flush volume and velocity shall be based on the manufacturer's specifications.

9.5.12.6 The filter residue shall be returned to the treatment facility.

9.5.13 Minimum Specifications for Subsurface Drip Disposal Fields

9.5.13.1 Drip disposal lines shall be installed in the "A" horizon six to eight inches (6" – 8") deep. The maximum depth shall not exceed eighteen inches (18"). In all cases, there shall be a minimum of twelve inches (12") separation between the water table and the restrictive horizon.

9.5.13.2 The drip lines may be installed using any of the following methods:

9.5.13.2.1 Installed in a trench excavated by a trenching machine.

- 9.5.13.2.2 Installed using an approved plowing method. The insertion tool must be of the type that does not pull or stretch the drip line during insertion. The use of “cable plows” or any type insertion method that employs pulling the drip line through the plowed trench is prohibited.
- 9.5.13.3 A subsurface drip disposal system shall contain, if necessary, pressure compensating devices or regulators to insure equal distribution from all emitters at +/- 10 % of the designed discharge rate.
- 9.5.13.4 The drip lines shall be on contour and shall not be installed perpendicular (or up and down, etc) to the slope. The difference in a drip line or the entire grid shall not exceed the manufacturer’s specifications.
- 9.5.13.5 The length of each distribution line shall not exceed one hundred feet (100’).
- 9.5.13.6 Vacuum breakers shall be installed based on the manufacturer’s specification, a minimum of one vacuum breaker / air release valve for each drip field zone.
- 9.5.13.7 All materials shall meet applicable American Society for Testing and Materials (ASTM) standards and be resistant to common manufacturer as designed and manufactured for the disposal of wastewater. **The drip line tubing must be color coded, by the manufacturer, to be easily identified as tubing designed for wastewater disposal.**
- 9.5.13.8 The separation between emitter line laterals shall be a minimum of two feet (2’).
- 9.5.13.9 Lateral spacing of three feet (3’) or more should be used for slopes 20% or greater.
- 9.5.13.10 Drip disposal tubing shall be either four inches (4”) lower than the supply manifolds or water breaks shall be used to prevent effluent from flowing from drip trenches to the supply manifold trenches.
- 9.5.13.11 Vacuum breaker shall be located in a protective enclosure that will prevent the accumulation of any substance that would prevent their proper operation and shall have a grade level access.

- 9.5.13.12 Equipment susceptible to freezing must be adequately protected to prevent freezing.
- 9.5.13.13 A system must be provided for the flushing of distribution lines to prevent the build-up of solids in the distribution system, with its discharge returning to the treatment facility. The system shall be capable of achieving a flushing velocity of a minimum of two feet per second (2 ft /s). The return line must be permanently installed as a component of the system. **A hose bib shall be prohibited as a component part of the drip disposal system.**

9.5.14 Placement of Subsurface Drip Disposal System.

- 9.5.14.1 All components of the drip disposal system shall be located a minimum of:
 - 9.5.14.1.1 Eight feet (8') from the foundation of any building, structure or retaining wall.
 - 9.5.14.1.2 Ten feet (10') from any property line.
 - 9.5.14.1.3 Twenty-five feet (25') from any water supply line and water circulation lines of a swimming pool or spa and pool equipment.
- 9.5.14.2 The aerobic treatment unit, pump chamber, and drip disposal field shall be located a minimum of one hundred feet (100') from any well or watercourse.
- 9.5.14.3 Where a water supply line must cross over a sewer line, the bottom of the water service within ten feet (10') of the point of crossing shall be at least eighteen inches (18") above the top of the sewer line.
- 9.5.14.4 The drip disposal field shall not be located in an area subject to vehicular access or traffic, or any area to be paved.
- 9.5.14.5 There shall be a ten feet (10') minimum horizontal separation between any tree and the drip disposal field, aerobic treatment unit or dosing chamber.

9.6 **Mound System.** Also known as the “Wisconsin Mound,” disposal is characterized by an above-grade infiltration bed system that blends with the land surface into which is dispensed pressure dosed wastewater from a septic tank or an alternative treatment system. Mound systems are usually installed in areas with high groundwater tables, slow or fast permeability soils, and shallow cover over creviced or porous bedrock.

9.6.1 Design of Mound System.

9.6.1.1 All mound systems shall be designed and all plans submitted, signed and sealed by a State of Nevada registered professional engineer. The design shall generally be based on the most current edition of the “Wisconsin Mound Soil Absorption System: Siting, Design and Construction Manual,” published by the University of Wisconsin – Madison Small-Scale Waste Management Projects, with the following inclusions:

9.6.1.2 The mound system may be built over natural existing soil with a percolation rate between three (3) to sixty (60) minutes per inch provided:

9.6.1.3 The minimum separation distance between the anticipated maximum groundwater table and the natural ground surface shall be twelve (12”) inches.

9.6.1.4 A minimum of one foot (1’) of mound fill and one foot (1’) of natural soil percolating between three (3) to sixty (60) minutes per inch is available to form the minimum two feet (2’) of unsaturated soil below the bottom of the absorption system.

9.6.1.5 At least thirty-six inches (36”) of suitable soil percolating between three (3) to sixty (60) minutes per inch is available between bedrock and impervious strata and the native ground surface.

9.6.1.6 Effluent shall be applied to the inlet surface of the mound media at not more than one (1) gallon per day per square foot of mound bed inlet surface if the mound bed media conforms with the “Standard Specification for Concrete Aggregates, C33-03,” published by the American Society for Testing Materials and the Wisconsin Mound manual, except if cinder sand is used that is the appropriate grade with not more than five percent (5%) passing a #200 screen.

9.6.1.7 The top and bottom surfaces of the aggregate infiltration bed shall be level and shall not exceed ten feet (10’) in width.

- 9.6.1.8 The minimum depth of the aggregate infiltration bed shall be nine inches (9").
- 9.6.1.9 The minimum thickness of aggregate media around the distribution pipes of the absorption system shall be equal to:
= six inches (6") below the distribution pipe + the diameter of the distribution pipe + two inches above the distribution pipe **or** ten inches (10"), whichever is greater.
- 9.6.1.10 The synthetic fiber placed on the top surface of the aggregate infiltration bed shall be permeable to water and air and capable of supporting the cap and topsoil load.
- 9.6.1.11 The slope of the native ground surface shall not exceed twenty-five percent (25%) for the installation of a mound system.
- 9.6.1.12 The aggregate infiltration bed and mound bed shall be capped by coarser textured soil, such as sand, sandy loam or silt loam. Clay or clay loam is prohibited.
- 9.6.1.13 Ports shall be included for inspection and monitoring to verify performance, including verification of unsaturated flow within the aggregate infiltration bed by:
- 9.6.1.13.1 Installing a vertical PVC pipe with a minimum diameter of four inches (4") as an inspection port at the end of the disposal line, and
 - 9.6.1.13.2 Installing the pipe with physical restraint to maintain the pipe position.
- 9.6.1.14 The main pressurized line and secondary distribution lines for the aggregate infiltration bed shall be equipped at appropriate locations with cleanouts to grade.
- 9.6.1.15 The top soil shall be graded to drain surface water from the system and adjoining area.
- 9.6.1.16 Setback shall be increased for the following down slope features to thirty feet (30') from the toe of the mound system:
- 9.6.1.16.1 Property line.
 - 9.6.1.16.2 Driveway.
 - 9.6.1.16.3 Foundation of building or structure.

9.6.1.16.4 Ditch or interceptor drain, or any feature that impedes water movement away from the mound.

9.6.2 Installation and Construction Details.

9.6.2.1 The site shall be cleared of vegetation and trees cut down in the vicinity of the basal area site to within two (2) inches of the surface. Leave boundaries and tree stumps and other herbaceous material that would excessively alter the soil structure if removed after the site is cleared. The native soil serving the basal area footprint shall be plowed along contours to a seven to eight inch (7" – 8") depth. Begin construction immediately after plowing.

9.6.2.2 Each layer of the system shall be placed to prevent differential settling and promote uniform density.

9.6.3 **Maintenance Provider.** A contract with a Health Authority approved maintenance provider is required for the life of all mound systems.

9.7 Absorption Trenches

9.7.1 The bottom of the trench shall be laid level at a minimum depth of thirty-six inches (36") below ground level. The width of the trench shall be a minimum of eighteen inches (18") to a maximum of thirty-six inches (36"). Trenches shall be spaced in accordance with the following formula: the minimum spacing between trenches, measured from sidewall to sidewall = 2 x total depth (distance from finished grade to bottom of excavation).

9.7.2 Trenches shall not be excavated when the soil is wet enough to smear or compact easily.

9.7.3 Trench bottom and sidewall areas damaged or compacted during excavation shall be raked to a depth of one inch (1") and loose material removed before gravel is placed in the trench.

9.7.4 Distribution piping shall be four inches (4") minimum diameter and PVC.

9.7.5 The distribution pipe shall be surrounded by clean graded gravel or rock ranging in size from one-half inch (1/2") to two and one-half inches (2-1/2"). The aggregate shall extend from at least two inches (2") above the top of the pipe to at least eighteen inches (18") but not more than seventy-two (72") below the bottom of the pipe.

- 9.7.6 The top of the aggregate shall be covered with untreated building paper, a two inch (2") layer of hay / straw to prevent the stone from becoming clogged by the earth backfill.
 - 9.7.7 The length of pipe lines and individual trenches shall not exceed one hundred feet (100').
 - 9.7.8 Aeration risers (see Figure 11) shall be required if the backfill cover over the distribution pipes exceeds three feet (3').
 - 9.7.9 Trench beds with multiple trench lines shall be equal in length.
- 9.8 **Aerobic Treatment Unit (ATU).** An aerobic treatment unit is used when enhanced biological processing is needed to treat wastewater with high organic content, when soil or site condition are not adequate for installation of a standard septic system, or when highly treated wastewater amenable to disinfection is needed.
- 9.8.1 Certification. All aerobic treatment units must be certified by the National Sanitation Foundation (NSF) Standard 40, Class I, or authorized by the Nevada Department of Environmental Protection (NDEP) or the State Health Authority.
 - 9.8.2 Design of Aerobic Treatment Unit
 - 9.8.2.1 ATUs shall only treat influent, which have a 100 mg/L to 300 mg/L total organic compounds, and 100 mg/L to 350 mg/L total suspended solids (TSS), unless certification provided by the manufacturer is approved by the Health Authority.
 - 9.8.2.2 The wastewater shall be delivered to the aerobic treatment unit by gravity flow either directly or by a lift pump.
 - 9.8.2.3 The ATU shall be constructed of non-corrosive materials.
 - 9.8.2.4 Mechanical and electrical components shall either be waterproofed and/or protected from the elements
 - 9.8.2.5 Air diffusers shall be constructed of PVC or other approved materials.
 - 9.8.2.6 A clarifier shall be provided after aeration.
 - 9.8.2.7 An interceptor or other pretreatment device shall be incorporated, if necessary, or if recommended by the manufacturer for pretreatment.

9.8.2.8 Ports for inspection and monitoring shall be provided to verify performance.

9.8.2.9 The ATU shall be equipped with an audio and visual alarm to warn of compressor failure / aerator failure and high groundwater.

9.8.3 Installation requirements for Aerobic Treatment Units.

9.8.3.1 Installation of the aerobic treatment components shall conform to manufacturer's specifications.

9.8.3.2 The excavation, foundation, and backfill placement shall be performed to prevent differential settling and adverse drainage conditions.

9.8.4 Operation and Maintenance.

9.8.4.1 A contract with a maintenance provider approved by the Health Authority is required for the life of all aerobic treatment units.

9.9 **Absorption Area.** The absorption area required for seepage pit, pipe and gravel leach field, and absorption trenches shall be determined from Table V using soil percolation test data.

TABLE V

Minimum Liquid Capacity of Septic Tank (in Gallons)	Required Absorption Bottom Area for Seepage Beds (Pipe and Gravel Leach Field) or Sidewall Area for Seepage Pits and Trenches (in Square Feet)							
	1000	350	400	450	635	775	1100	1345
1200	420	480	540	760	935	1315	1610	1860
1500	520	600	710	350	1165	1645	2015	2325
2000	700	800	900	1272	1550	2200	2690	3100
2250	788	900	1013	1429	1744	2475	3075	3488
2500	875	1000	1125	1588	1940	2750	3363	3875
2750	963	1100	1238	1747	2132	3025	3699	4263
3000	1050	1200	1350	1905	2325	3300	4035	4650
3250	1138	1300	1463	2064	2519	3575	4371	5038
3500	1225	1400	1575	2223	2713	3850	4708	5425
Percolation Rate Time in Minutes for Water to Fall One Inch (1")	3 (c)	4	5	10	15	30 (a)	45 (a)	60 (a) & (b)
<p>NOTE: Reduce absorption field area by thirty percent (30%) when using leaching chambers</p> <ul style="list-style-type: none"> a) Unsuitable for seepage pits if over thirty (30) b) Soils with a percolation rate over sixty (60) minutes per inch shall not be used for absorption systems c) A minimum percolation rate of three (3) minutes per inch shall be used to calculate absorption area requirements. 								

9.9.1 **Dosing Tanks.** When the quantity of septic tank effluent to be discharged into the soil absorption system exceeds the amount that can be disposed of through five hundred (500) lineal feet of pipe, a dosing tank, equipped with an automatic siphon, shall have a capacity equal to combined volume of the pipe lateral exceeds one thousand feet (1,000'), the dosage tank shall be provided with two (2) automatic siphons dosing alternately and each serving one-half (1/2) of the pipe field.

NOTE: Each foot of four-inch (4") pipe has a capacity of 0.652 gallons; five-inch (5") pipe, 1.02 gallons; six-inch (6") pipe 1.46 gallons; seven-inch (7") pipe, 2.012 gallons; eight-inch (8") pipe, 2.599 gallons; 10-inch (10") pipe, 4.0195 gallons; 12-inch (12") pipe, 5.875 gallons. The amount of pipe required is governed by the lay of the land and character of the soil. This is important and must receive careful attention. The drainage surface of the ground and in cases where it is necessary to lay the pipe deeper than three feet (3'), an adequate system of ventilation should be provided.

9.10 **Sand Layer Requirement.**

9.10.1 If the soil percolation rate is less than one (1) minute per inch, a sand layer shall be required. The sizing of the absorption field shall be the minimum absorption field area that corresponds to three (3) minutes per inch percolation rate.

9.10.2 The geo-textile fabric shall be "Mirafi" (140 NC) or equal N-series non-woven polypropylene for soil separation, filtration and protection. The sand layer shall utilize fine sand or loamy sand with the following gradation and requirements:

<u>Sieve Size</u>	<u>Percentage by Weight Passing</u>
3/8"	100%
No. 4	80% - 100%
No. 200	0% - 5%

9.10.3 The plasticity index shall not exceed nine (9). The soluble sulfate content shall not exceed 0.3% by dry weight of soil. The uniformity coefficient shall be less than four (4). The infiltration rate shall be between 1.5 gpd /sf and 2.5 gpd / sf. A sieve analysis of the sand to be used for the sand layer shall be submitted for approval to the Health Authority prior to the sand layer inspection.

9.10.4 The sand layer shall be a minimum of twenty-four (24") inches below the absorption field.

9.10.5 Sand Layer with Chamber Leach Field (see Figure 10):

9.10.5.1 There shall be at least two (2) inspections by the Health Authority:

First Inspection: Inspection of the excavation below subsequent placement of leaching chambers, with the bottom of the excavation exposed to verify that bedrock is fractured to a minimum depth of two feet (2') below the bottom of proposed leaching chambers, and that the bottom of the excavation is lined with the geo-textile fabric.

Second Inspection: Inspection to verify that a sand layer at a minimum of twenty four inches (24") is overlying geo-textile fabric and that the fabric extends at least six inches (6") vertically above top of sand layer. The chamber leach field and septic tank installed shall be inspected to determine if it is in compliance with these Regulations.

9.10.5.2 Sand Layer with a Pipe and Gravel Leach Field (See Figure 10A):

There shall be at least two (2) inspections by the Health Authority:

First Inspection: Inspection of the excavation below the subsequent placement of coarse gravel ($\frac{1}{2}$ " to 2 $\frac{1}{2}$ "), with the bottom of the excavation exposed to verify that bedrock is fractured to a minimum depth of two feet (2') below the bottom of the proposed pipe and gravel leach field, and that the bottom of the excavation is lined with the geo-textile fabric.

Second Inspection: Inspection to verify that a sand layer at a minimum of twenty four inches (24") is overlying geo-textile fabric and that the fabric extends at least six inches (6") vertically above top of sand layer. The pipe and gravel leach field and septic tank installed shall be inspected to determine if it is in compliance with these Regulations.

Section 10

NITROGEN REMOVAL SYSTEMS

- 10.1 A **nitrogen removal system** is a system that receives sewage, and through biological denitrification, chemical reduction or ion exchange reduces the total nitrogen level of the effluent to less than or equal to ten (10) milligrams per liter or parts per million, measured as total nitrogen.
- 10.2 **Approval.** All nitrogen removal systems must be approved by the Health Authority through a product review process. A list of approved nitrogen removal systems and their manufacturers can be requested from the Health Authority.
- 10.3 **NSF Certification.** All nitrogen removal septic systems must be approved by the National Sanitation Foundation (NSF) Standard 40, Class I, or authorized by the NDEP or the State Health Authority, prior to application to SNHD through its product review process.
- 10.4 Design for Nitrogen Removal Septic Systems.
- 10.4.1 The wastewater shall be delivered to the nitrogen removal system by gravity flow either directly or by a lift pump.
 - 10.4.2 The nitrogen removal system shall be constructed from non-corrosive materials.
 - 10.4.3 All mechanical and electrical components shall be waterproofed and/or protected from the elements. Electrical components shall be protected with safety devices (ground fault circuit interrupters, fuses, etc).
- 10.5 Installation Requirements for Nitrogen Removal Septic Systems.
- 10.5.1 Installation of the nitrogen removal septic system components shall conform to the manufacturer's specifications.
 - 10.5.2 The excavation, foundation and backfill placement shall be performed to prevent differential settling and the adverse effects of drainage.
- 10.6 Operation and Maintenance.
- 10.6.1 A current contract with a maintenance provider approved by the Health Authority is required for the life of all nitrogen removal septic systems. New property owner (s) shall provide the Health Authority with an updated maintenance contract within thirty (30) days from the close of escrow.
 - 10.6.2 If there is a change in the maintenance provider, the property owner must provide with a new Health Authority approved maintenance provider's contract within thirty (30) days.

- 10.6.3 The maintenance provider shall sample and test for total nitrogen on a quarterly basis starting ninety (90) days after approved final inspection or date of occupancy, and every year thereafter for as long as the system is required to be operational. The maintenance provider shall provide unmodified test results to Health Authority from the testing laboratory. The Health Authority may at any time request and/or conduct additional sampling and testing to insure compliance. Any maintenance provider not adhering to these Regulations, at the discretion of the Health Authority, shall be removed from the Approved Maintenance Provider list
- 10.6.4 The nitrogen removal system effluent shall be tested by a laboratory certified by the Nevada State Health Division.

10.7 Annual Nitrogen Removal System Surveillance

- 10.7.1 An **annual nitrogen removal system surveillance fee** shall be required in the amount specified in the current SNHD Environmental Health Fee Schedule.
- 10.7.2 All nitrogen removal systems shall be inspected by the Health Authority at least once per year starting one year from the date of approved final inspection, until proof of municipal sewer connection is provided and the septic system is abandoned according to **Section 17** of these Regulations. The inspection shall be in accordance with **Section 16** of these Regulations.
- 10.7.3 If the annual surveillance inspection is not approved, a re-inspection fee in the amount specified in the current SNHD Environmental Health Fee Schedule shall be applicable. The re-inspection fee must be paid prior to scheduling another inspection.

10.8 Revocation of Nitrogen Removal System Permit

- 10.8.1 The Health Authority may revoke a Nitrogen Removal System permit if applicable fees are not paid, annual inspections are not approved or resolved within sixty (60) days of the inspection date, effluent test results are not provided to the Health Authority as required, or the effluent test results consistently do not meet the required parameters, and/or the property owner does not have an approved maintenance contract.
- 10.8.2 The Health Authority shall not approve Tenant Improvements, pool plans, or certifications for revoked permits
- 10.8.3 If municipal sewer is more than four hundred (400') feet from the nearest property line, the revoked Nitrogen Removal System permit may be activated

by paying all accumulated fees and meeting all the requirements in **Section 10**, including an approved annual inspection.

- 10.8.4 If gravity connection to municipal sewer is available within four hundred (400') to the nearest property line, then the revoked Nitrogen Removal System permit shall not be activated. Municipal sewer connection and abandonment of the existing ISDS according to **Section 17** shall be required.

Section 11

SPECIFIC LIMITATIONS AND REQUIREMENTS

- 11.1 The use of cesspools for the disposal of untreated sewage is prohibited.
- 11.2 The discharge of surface rain and other large volumes of clear water into an individual sewage disposal system are prohibited.
- 11.3 All trees shall be at least ten feet (10') from both the septic tank and leach field.
- 11.4 The disposal of water from swimming pool or spa into or over the septic system is prohibited. The disposal of backwash waste from pool or spa filters into the septic system is prohibited.
- 11.5 The disposal of recreational vehicle (RV) waste into the septic system is prohibited.
- 11.6 The disposal of oils, grease, flammable toxic products and chemicals, pharmaceutical products, which includes, without limitation: gasoline, motor oil, household cleaners, pool/spa products, chlorides, pesticides, herbicides, agricultural chemicals or fertilizers, pills, capsules and tablets, into the septic system is prohibited.
- 11.7 Irrigation above the ground surface with effluent is prohibited.
- 11.8 The design of all prefabricated septic tanks shall be approved by the Health Authority prior to their installation.
- 11.9 The five foot (5') minimum vertical separation shall be maintained between the bottom of the soil absorption system and the maximum seasonal elevation of the groundwater table. In areas where it is presumed that the groundwater level is high, that is, less than nine feet (9') from finished grade to the highest seasonal groundwater level, a boring shall be provided to the Health Authority. The boring log may be submitted from the geotechnical report for a proposed building or structure.
- 11.10 An individual sewage disposal system may serve only one (1) single building for commercial applications.
- 11.11 The Health Authority shall review every sewage disposal system proposed for single buildings containing multiple dwelling units or single building multi-unit warehouses to determine compliance with all pertinent state and local Regulations.

- 11.12 A septic tank shall not be installed independently without a soil absorption system to receive the septic tank effluent.
- 11.13 A soil absorption system shall not be in the fifty (50) year flood plain:
- 11.13.1 When soil absorption systems are located in the one hundred (100) year flood plain, the septic tank will be made waterproof by completely coating the tank and having a minimum of twelve inches (12") of soil over the top.
- 11.14 A soil absorption system shall not be installed in a non-compacted fill area without approval from the Health Authority.
- 11.15 An individual sewage disposal system is prohibited in an area subject to vehicular access or traffic, or any area to be paved.
- 11.16 The placement of any impervious covering, or any material deemed to be unacceptable to the Health Authority, over the soil absorption system is prohibited.
- 11.17 A pre-site evaluation inspection by the Health Authority shall be required before application is made for a septic system permit in Mount Charleston, and any other environmentally sensitive area, as determined by the Health Authority.
- 11.18 A septic system shall not be constructed in an easement of any kind, unless the easement is for that purpose.
- 11.19 All change (s) in directions of sewers in a sewage disposal system shall be accomplished by the use of ninety (90) degree bends or lesser angle bend pipe fittings.
- 11.20 **Lot Size (s) Requirement:**
- 11.20.1 A minimum area of one (1) acre (43,560 square feet), including public streets and alleys, or other right-of-way or easements, or any portion thereof abutting on, running through or within a building site, is required for the installation of an individual sewage disposal system where the water supply is from a well serving only that property.
- 11.20.2 A minimum of one-quarter (1/4) acre (10,900 square feet), including public streets or alleys or other rights-of-way or easements, or any portions thereof abutting on, running through or within a building site, is required on a lot served by a community well or municipal water.

- 11.21 Excavations for the septic tank and leach field shall be separated by a minimum of five (5') feet of undisturbed earth. (See Figure 4)
- 11.22 The requirement for allocating an area for the installation of another leach field (equal in size to the original leach field) if the original leach field should fail will not normally be required by the Health Authority. The requirement for a backup leach field area may be required, however, based on the specific system proposed at the discretion of the Health Authority.
- 11.23 These Regulations shall not preclude the use of treatment devices other than septic tanks, as may be approved by the Health Authority. Such treatment devices shall bear the certification of the National Sanitation Foundation (NSF).
- 11.24 The use of sweeping T's is prohibited.
- 11.25 Provisions not covered by these Regulations shall meet the requirements of the latest edition of the Uniform Plumbing Code (UPC).
- 11.26 ISDS must be constructed on and remain on the same parcel as the structure(s) it serves.
- 11.27 Floor drains are not allowed in garages because of the potential of introducing industrial system into the ISDS (see NAC 444.759 and NAC 444.8766)

Section 12

SEWER CONNECTION

- 12.1 When community sewers become available, the owner of any property served by an individual sewage disposal system shall abide by the local governmental regulation requiring connection to the community sewerage system.
- 12.2 The individual septic system shall be discontinued and the structure shall be connected to the community sewerage system when the owner is notified to do so.
- 12.3 All abandoned septic tanks shall be immediately pumped and filled with dry earth and proof supplied to the Health Authority (See **Section 17** for applicable abandonment procedure).

Section 13

INDUSTRIAL WASTES

- 13.1 Treatment and disposal systems for industrial wastes shall be individually designed and shall be of a type that will adequately purify the specific waste. Any system designed to treat industrial waste must be approved by the Health Authority.
- 13.2 Owners of industrial establishments producing trade wastes of toxic, putrescible, or otherwise hazardous character shall consult with the Health Authority and comply with the instructions and requirements in the design of their systems.

Section 14

LAND SLOPE REQUIREMENTS

14.1 As the slope of the ground increases, the minimum depth to the bottom of the soil absorption system must be increased to prevent effluent from discharging downhill. The minimum depth from top of existing ground to the bottom of the soil absorption system shall be as follows: (See Figure 7)

14.1.1 For slope less than five percent (5%), no increase. The depth to the bottom of the soil absorption system shall be thirty-six inches (36") minimum.

14.1.2 For slopes five percent (5%) but less than ten percent (10%), minimum depth shall be forty-eight inches (48").

14.1.3 For slopes ten percent (10%) but less than twenty percent (20%) minimum depth shall be sixty inches (60").

14.1.4 Slopes greater than twenty percent (20%)

Depth equals three feet (3') plus ten (10) times the percent of slope.
[$D = 3' + 10 (\% \text{ of slope})$]

For example: If slope equals twenty-eight percent (28%):
 $D = 3' + 10 (0.28) = 3 + 2.8 = 5.8 \text{ ft}$

This is the minimum depth to bottom of soil absorption system

14.2 **Supplemental Horizontal Requirements.** Regardless of the slope of the land, the distance from the soil absorption system to any ground surface (face to slope) shall be removed at least twenty feet (20') (measured vertically and horizontally). The Health Authority may require additional horizontal clearances from face of slope after evaluating the topographical and/or geologic conditions of a specific site. (See Figure 8)

Section 15

SOIL PERCOLATION RATES AND SOIL CHARACTERIZATION

15.1 Soil Boring and Percolation Tests.

- 15.1.1 Soil boring and percolation tests shall be made or be supervised by professional engineer, registered in Nevada. The person supervising the tests shall certify as to the correctness of the procedure and the results.
- 15.1.2 Percolation test data from a minimum of two (2) test holes on the area of the proposed soil absorption system shall be required. The location of the test holes shall be indicated on a site plan of the property and submitted with the percolation test results to the Health Authority.
- 15.1.3 Percolation tests are only acceptable for the parcel on which the test was conducted, in the area of proposed soil absorption system.
- 15.1.4 A new percolation test shall be required if the soil composition is changed, an engineered fill is utilized, a septic system fails or any other purpose as deemed necessary by the Health Authority.

15.2 Percolation Test Procedure.

- 15.2.1 **Type of hole.** The hole shall be dug or bored. It shall have vertical sides and have a horizontal dimension of four to twelve inches (4" to 12"). A four inch (4") or larger auger may be used. The hole shall be dug to the depth of the proposed absorption trench, bed, field, or pit.
- 15.2.2 **Preparation of hole.** The bottom and sides of the hole shall be carefully scratched with a sharp-pointed instrument to expose the natural soil interface. All loose material shall be removed and from the bottom of the hole which shall then be covered with two inches (2") of coarse sand or gravel when necessary to prevent scouring.
- 15.2.3 **Saturation and swelling of the soil.** The hole shall be carefully filled with clear water to a minimum depth of twelve inches (12") over the gravel. By refilling, if necessary, or by supplying a surplus reservoir of water, such as an automatic siphon, the test hole shall be filled with water for at least four (4) hours and preferably overnight, so that it will approach the conditions that will exist during the wettest season of the year. In sandy soils, containing little or no clay, the swelling procedure is not essential and the test may proceed, as hereafter described, if the water from a second filling of the hole seeps away in ten (10) minutes or less.

15.2.4 **Percolation rate measurements.** With the exception of sandy soils, percolation rate measurements shall be made on the day following the procedure described in **Section 15.2.3** above. If water remains in the test hole after an overnight swelling period, the depth shall be adjusted to a level of six reference point, the drop in water level shall be measured over thirty (30) minutes, or longer period. This drop shall be used to calculate the percolation rate. If not water remains in the hole after the overnight swelling period, there shall be added clear water shall be added to bring the depth of the water in the hole to a level which is six inches (6") over the gravel. Thereupon, from a fixed reference point, the drop in water level shall be measured at thirty (30) minute intervals until two (2) successive readings do not vary by more than five percent (5%), or for a period of four (4) hours, refilling the hole whenever it becomes nearly empty with clear water to a level which is six inches (6") above the gravel. The drop that occurs during the final two (2) successive thirty (30) minute periods with less than a five percent (5%) difference shall be used to calculate the percolation rate. Percolation rates may also be determined by the volume of the water displaced from a reservoir when accurately determined and the water feeding device is such as to maintain a constant water level in the hole.

15.2.5 **Interpretation.** In interpreting percolation test results, emphasis shall be given to the highest percolation rates for the same type of soil, and this shall be rounded-up to the nearest whole number. The final interpretation of the soil percolation test result (s) shall be made by the Health Authority.

15.3 **Soil Borings.**

15.3.1 Soil borings shall be drilled to a depth of five feet (5') beyond the depth of the soil percolation test hole.

15.3.2 Soil borings shall indicate whether or not groundwater was encountered, and if groundwater was encountered, the depth shall be indicated.

15.4 **Soil Characterization.**

In lieu of soil percolation tests, the Health Authority may consider soil characterization methodologies in approving the design of soil absorption systems.

Section 16

INSPECTIONS OF INDIVIDUAL SEWAGE DISPOSAL SYSTEMS

- 16.1 Inspections by the Health Authority shall be required prior to covering the sewer line, septic tank and soil absorption system or commercial holding tank.
- 16.2 The Health Authority must have access to the property and area where the individual sewage disposal system is being inspected. Gates must be unlocked and animals restrained. If the property is located in a gated community, the gate access code must be provided.
- 16.3 All requests for inspections must be received by the Health Authority at least twenty-four (24) hours in advance. The request must include the septic system permit number, the Assessor's Parcel Number (APN) or the address for the property, along with the contact name and number of the person requesting the inspection.
- 16.4 The Health Authority reserves the right to schedule inspections in outlying areas on a particular day of the week **or** to reschedule inspections. The Health Authority also reserves the right to cancel an inspection if conditions on the property pose an immediate threat to human life or health.
- 16.5 A pre-site evaluation inspection by the Health Authority shall be required before application is made for a septic system permit in Mount Charleston, and any other environmentally sensitive area as determined by the Health Authority.
- 16.6 Inspections may be required by the Health Authority for site surveys and evaluations.
- 16.7 For commercial holding tanks, the Health Authority must have access inside the modular/trailer to check for running water connection
- 16.8 In case of questionable soil conditions, inspections will be required prior to any installation.
- 16.9 Until the sewage disposal system inspection is approved by the Health Authority, there shall be no occupancy of the building
- 16.10 If the inspection of the individual sewage disposal system in **not approved**, a re-inspection fee will be applicable. The re-inspection fee shall be according to the current SNHD Environmental Health Fee Schedule. The re-inspection fee must be paid prior to scheduling another inspection.

16.11 Inspections of existing septic systems require the entire septic tank, entire header line and at least one (1) end cap closest to the structure to be uncovered at the time of inspection. The lids of the septic tank must be removed. The Health Authority reserves the right to charge an inspection fee according to the current SNHD Environmental Health Fee Schedule.

Section 17

REMOVAL AND ABANDONMENT OF SEPTIC TANK AND LEACH FIELD

- 17.1 An individual sewage disposal system (ISDS) may be abandoned due to replacement, failure, or connection to municipal sewer. If a septic system is being replaced and connection to municipal sewer is not required based on these Regulations, a new septic system permit shall be obtained from the Health Authority. This new septic system shall be inspected and approved by the Health Authority prior to being used for sewage disposal. If the property is being connected to municipal sewer, a receipt from the municipal sewer authority showing that the fees for sewer connection have been paid shall be submitted to Health Authority.
- 17.2 Abandonment of Septic Tank and Leach Field in Place.
- 17.2.1 Abandonment of Septic Tank.
- 17.2.1.1 The septic tank shall be pumped with pumping receipt submitted to the Health Authority from a Health Authority permitted liquid waste hauler.
- 17.2.1.2 The septic tank shall either be crushed **OR** filled with dry earth with proof provided to Health Authority in the form of receipts or before and after photos (from the same angle).
- 17.2.2 Abandonment of Leach Field.
- 17.2.2.1 A written note from the owner or contractor shall be provided to the Health Authority stating that the leach field is abandoned in place
- 17.3 If the septic tank is within eight feet (8') of an existing or future structure, it must be pumped and removed to a Health Authority approved disposal facility with receipts provided to the Health Authority. **Any part** of the leach field within eight feet (8') for a shallow absorption system or twenty feet (20') for a deep absorption system must also be removed with copies of receipts provided to Health Authority as listed above.
- 17.4 Removal of Septic Tank and Leach Field
- 17.4.1 Removal of Septic tank and leach field
- 17.4.1.1 The septic tank shall be pumped with a copy of the pumping receipt submitted to the Health Authority from a Health Authority permitted liquid waste hauler.

- 17.4.1.2 The septic tank shall be disposed of at a Health Authority approved disposal facility with receipts provided to the Health Authority.
- 17.4.1.3 Any stained soil shall be removed to the end of the stain mark or within a **two (2) feet maximum distance to the bottom and sides of the entire length and width of the leach field and leach lines** to a Health Authority approved disposal facility, and provide the Health Authority with receipts.

Section 18

SOLID AND LIQUID WASTES: GENERATED FROM SEPTIC TANK, HOLDING TANK, CHEMICAL TOILET WASTE, OR GREASE INTERCEPTOR TANK OR INEDIBLE KITCHEN GREASE CONTAINERS, AND PUMPING AND HAULING CONTRACTORS (INCLUDING PETROLUEM HYDROCARBON CONTAMINATED WASTE WHICH MAY BE GENERATED BY SAND-OIL-WATER SEPARATORS)

- 18.1 **Waste permittee** means all persons engaged in the operation of removing, hauling and disposing of the solid and liquid contents of septic tanks, holding tanks, chemical toilets, grease interceptor tanks, inedible kitchen grease containers or sand-oil-water separators within Clark County. Permits must be obtained annually from the Health District.
- 18.2 **Permit Requirements.** This permit must contain the following information:
- 18.2.1 Type of waste to be hauled – liquid or effluent from septic tank, holding tank, chemical toilet, grease interceptor tank, inedible kitchen grease, and sand-oil-water separators. Liquid wastes from sand-oil-water separators must not be blended with other liquid wastes.
 - 18.2.2 Location of all discharge points and type of waste discharged at each location
 - 18.2.3 License number and state registration of each truck
 - 18.2.4 Capacity of each truck
 - 18.2.5 A statement signed by the vehicle operator that all waste material collected will be disposed of in accordance with these Regulations and that such waste will not be discharged to a waterway, sewer, or deposited on land without prior approval of the Health Authority.
- 18.3 **Septic tank waste** shall mean any sanitary waste from a septic tank for human waste at a residential or commercial location. None of these wastes shall contain industrial waste, toxic wastes, radiological waste, and/or hazardous waste as defined in the Resource Conservation and Recovery Act (RCRA), including its applicable regulations (RCRA, 40 CFR 26, a copy of which is on file with the Environmental Health Division of the District). The generator of a waste is responsible for the proper disposal thereof.
- 18.4 **Chemical toilet waste** shall mean any sanitary waste from a portable toilet or one-door movable sanitary facilities. None of the waste shall contain wastes prohibited in **Section 18.3.**
- 18.5 **Holding tank waste** shall mean sanitary waste from temporary holding tanks for commercial facilities. None of the wastes shall contain wastes prohibited in **Section 18.3.**

- 18.6 **Grease interceptor waste** shall mean non-petroleum based grease, oil, and fats generated with wastewater from fixtures and equipment such as, but not limited to, scullery sinks, pot and pan sinks, dishwashing machines, soup kettles and similar cooking equipment, trash compactors, floor drains in grease generating areas, and trash can washing areas of foodservice establishments.
- 18.7 **Inedible kitchen grease** shall mean fat or used cooking grease and oils obtained from kitchen grease generators.
- 18.8 **Industrial liquid waste** shall mean that which is generated by manufacturing or commercial process that is not a hazardous waste regulated within Subtitle C of RCRA (40 CFR 261). This includes sand-oil-water separators from automatic services, and equipment washing businesses.
- 18.9 **Vehicle identification.** The name, address, and phone number of the waste permittee and the permit number shall be legibly lettered on both sides of each vehicle used for activities defined herein. The size of the lettering shall be at least two inches (2”), placed on a contrasting background.
- 18.10 **Vehicle maintenance.** Every vehicle used for pumping or hauling of effluents set forth in **Section 18** shall be equipped with a watertight tank or body except when hauling solid inedible kitchen grease and be maintained in a clean and sanitary condition. Liquid wastes shall be maintained so as to prevent the release of a pollutant into the waters of the State.
- 18.11 **Portable receptacles.** All portable receptacles used for transporting liquid or septage wastes shall be watertight, equipped with tight-fitting lids, and shall be cleaned after each use.
- 18.12 **Disposal site.** Prior approval in writing shall be obtained from the Health Authority for every destination to which a septic tank, holding tank, chemical toilet, grease interceptor, or industrial liquid waste permit holder plans to discharge waste material collected. Liquid waste collected by the waste permittee shall only be discharged at an approved facility.
- NOTE: Emergency sanitary waste disposal points will be established with the concurrence of the appropriate government official. The waste permittee will be responsible for notifying the Health Authority within 24 hours of the beginning of the emergency operation.
- 18.13 **Record keeping requirements concerning inedible kitchen grease:** Every waste permittee of inedible kitchen grease shall record, make available to the Health District as requested, and maintain for one year all of the following:

- 18.13.1 The name and address of each location from which the waste permittee obtained the inedible kitchen grease.
 - 18.13.2 The quantity of grease received from each location.
 - 18.13.3 The date on which the inedible kitchen grease was obtained from each location.
 - 18.13.4 The name and address of the processing plant (renderer) to which the inedible kitchen grease was transported.
 - 18.13.5 The date and quantity of inedible grease transported to the processing plant (renderer).
- 18.14 **Documentation and filing of reports.** Each waste permittee is required to keep accurate records via a manifest system approved by the Health Authority. This monthly audit trail of all liquid waste collected must include the generator/source; the amount removed for disposal including date and time of collection; vehicle permit number; and a proper receipt for discharge of the liquid waste at an approved disposal site.
- 18.15 **Automatic shutoffs.** All pumping equipment on waste permittee trucks shall be fitted with automatic shutoff valves.
- 18.16 **Suspension or Revocation of Waste Permittees' Permits.** Permits shall be subject to suspension or revocation by the Health Authority for violation of these Regulations, or Clark County Water Reclamation District Resolution No. 91-014, in accordance with the following procedures or permit conditions:
- 18.16.1 Staff shall serve upon the waste permittee, personally or by certified mail, a written, detailed statement of the charges against him together with a notice of hearing before the Health Authority stating the time, date, place, and purpose of the hearing.
 - 18.16.2 The waste permittee may appear in person or with counsel, and shall be extended a full opportunity to call witnesses and produce evidence to counter the charges made against him.
 - 18.16.3 The decision of the Health Authority in writing, shall contain findings of fact and conclusions of the law separately stated, and shall be served upon the waste permittee within 10 days of the hearing, personally or by certified mail.
 - 18.16.4 The Health Authority reserves the right to issue a temporary suspension order immediately effective, if a significant public health hazard exists.

18.7 **Fee(s).** Pursuant to NRS 439.360(5) and NRS 439.366(1), the Board adopts by reference the current SNHD Environmental Health Permit Fee Schedule as it applies to liquid waste haulers. All fees must be paid to the Health Authority prior to scheduling an inspection. All fees related to liquid waste haulers shall be non-refundable.

Section 19

HEARING AND APPEALS

19.1 Requests for variances from the provisions of these Regulations may be reviewed by the District Board of Health at its regular monthly meetings, in accordance with the following terms, conditions, and procedures.

19.2 Application for Variances

19.2.1 Persons seeking variances from any provision of these Regulations may apply for a variance order from the Board by filing a written application with the Environmental Health Division on forms provided by the Health Authority for that purpose.

19.2.2 The application shall include the following information:

19.2.2.1 The applicant's name and mailing address.

19.2.2.2 The property address.

19.2.2.3 The specific provision (s) of the Regulations for which variance is requested.

19.2.2.4 A brief statement from the applicant regarding the reasons for the variance.

19.2.2.5 Any information as may be required by the Health Authority to enable it to process the application.

19.2.2.6 The street address (if any) and legal description of the property affected.

19.2.2.7 A plot plan showing dimensions of the property, and the locations and dimensions of the proposed septic tank and leach field shown in relation to any structures on the property, whether proposed or already existing.

19.2.2.8 Evidence of an ownership interest in the affected property vested in the applicant.

19.2.2.9 The application shall be accompanied by a nonrefundable filing fee in the amount specified in the current SNHD Environmental Permit Fee Schedule.

19.3 Notice of Hearing

19.3.1 The applicant shall be notified in writing of the date, time, and place of the hearing before the Board on application for variance, and of the right to appear and be heard at such hearing.

19.3.2 A notice of the hearing on the application shall be published at least once by the Health Authority in newspaper of general circulation published in Clark County, Nevada, best suited to give notice to the public in the area where the affected property is situated, at least fourteen (14) days before the hearing scheduled on the application. The notice shall state:

19.3.2.1 The name of the applicant.

19.3.2.2 The location of the property.

19.3.2.3 The nature of the variance requested.

19.3.2.4 The date, time, and place of the hearing.

19.3.2.5 That all interested persons are entitled to appear at the hearing and state their views or provide relevant information regarding the application, or to furnish the same in writing prior to the hearing.

19.3.2.6 The Health Authority shall mail a copy of the public notice to the property owners adjoining the affected property.

19.4 **The Hearing.** At the time and place set for the hearing, the Board shall utilize the following procedures:

19.4.1 Staff shall be asked to comment on the application and state their recommendation regarding the same. Staff will not recommend variance approval for septic systems on lots where municipal sewer is gravity accessible within four hundred feet (400') from the nearest property line.

19.4.2 The applicant, or authorized representative, shall be given an opportunity to address the Board and to present any additional evidence, if any, that may support the application.

19.4.3 Other interested persons may then address the Board and present evidence relevant to the application.

19.4.4 The Board shall then publicly consider the application and reach a decision; however, the final vote on the decision may be postponed until the next regular meeting of the Board.

19.4.5 No person shall be entitled to a variance as a matter of right, and the burden of proof as to the justification for the variance shall be on the applicant.

19.4.6 Formal rules of evidence are not applicable in conducting the hearing, but the Board may exclude redundant or irrelevant evidence or testimony.

19.5 **Criteria.** In reaching a decision on an application, the Board shall consider the relative interests of first, the public; second, other property owners likely to be affected; third, the applicant; in that order.

19.5.1 No variance shall be granted in the absence of a showing that:

19.5.1.1 The variance would not endanger or tend to endanger human health or safety.

19.5.1.2 Compliance with the Regulation from which the variance is sought would produce serious hardship without equal or greater benefits to the public.

19.5.1.3 The applicant shall comply with all other provisions of applicable law and Regulations in the installation and maintenance of the sewage disposal system and/or septic tank pumping contractor permits.

19.6 **The Order**

19.6.1 Within fourteen (14) days after the final decision of the Board, a formal written Variance Order shall be signed by the Chairman, Vice Chairman, or acting Chairman stating the decision of the Board, and personally delivered or mailed to the applicant address given on his application.

19.6.2 The Order shall describe the subject property, identify the specific sections of these Regulations from which the variance was sought, state the decision of the Board, and the findings of fact upon which it was based.

19.6.3 The Order shall also set forth any conditions imposed by the Board for the granting of the variance.

19.6.4 A copy of the Order shall be recorded in the office of the Clark County Recorder.

19.7 Duration of Variance

- 19.7.1 Variance for the installation of the sewage disposal system shall expire and be of no further force and effect twelve (12) months after it is granted unless the applicant or the successors in interest commence construction of the individual sewage disposal system within that period of time, or an extension of the variance is granted by the Board by application made within that period of time by the applicant or the successors in interest.
- 19.7.2 If ISDS construction has been started within twelve (12) months of the variance approval, and the ISDS permit expires, the variance may stand for the property as long as the applicant (s) for the variance continue(s) to be the owners of the property and no changes in the design/ plot plan are made. If the variance granted is to be considered for a new ISDS permit to replace the expired ISDS permit, the variance applicant (s) must re-apply for a ISDS Permit to construct (See **Section 2.2**).
- 19.7.3 All such variances are temporary. They are automatically revoked in the event a community sewerage system becomes available within four hundred feet (400') to which a connection can be made by gravity flow, and legal notice is given to the then record owner of the property requiring connection with such community sewerage system.
- 19.7.4 A variance may be revoked for failure of the property owner to comply with any of the conditions imposed thereon by the Board or a violation of other applicable laws and regulations, upon notice and hearing.

19.8 ISDS Hearing Officer Process

- 19.8.1 The District Board of Health shall appoint an Individual Sewage Disposal Systems Hearing Officer(s) who shall adjudicate alleged violations of all Individual Sewage Disposal Systems Regulations and matters for which a hearing is provided by law. The Hearing Officer(s) shall act independent of each other regarding decisions. The Hearing Officer(s) shall have a working knowledge of environmental health issues, arbitration, law and/or engineering.
- 19.8.2 Hearing Officer(s) shall be selected by the District Board of Health from qualified applicants to the Health District. Such individual(s) shall not be employees of the State or any political subdivision of the State. The Hearing Officer(s) will be an independent contractor who serves at the pleasure of the District Board of Health, paid in accordance with a fee schedule approved by the District Board of Health.
- 19.8.3 Adjudication by the Hearing Officer(s) of alleged violations of the Individual Sewage Disposal Systems Regulations shall be in accordance with the following:

- 19.8.3.1 All parties must be afforded an opportunity for a hearing after reasonable notice. The Notice must include a statement of the time, place and nature of the hearing; a reference to the particular sections of the statutes and regulations involved; and a short and plain statement of the matters asserted.
- 19.8.3.2 Any party may be represented by counsel.
- 19.8.3.3 Opportunity shall be afforded all parties to respond and present evidence and argument on all issues involved.
- 19.8.3.4 Each party may call and examine witnesses, introduce exhibits, cross examination of opposing witnesses on any matter relevant to the issues even though the matter was not covered in the direct examination, impeach any witness, regardless of which party first called him to testify, and rebut the evidence against it.
- 19.8.3.5 Every witness shall declare, by oath or affirmation, that he will testify truthfully. Unless limited by a specific statute, the Hearing Officer(s) may administer oaths or affirmations to witnesses appearing before him in the hearing.
- 19.8.3.6 Irrelevant, immaterial or unduly repetitious evidence must be excluded. Evidence may be admitted, except where precluded by statute, if it is of a type commonly relied upon by reasonable and prudent persons in the conduct of their affairs. Effect shall be given to the rules of privilege recognized by law. Objections to evidentiary offers may be made and shall be noted in the record. Subject to these requirements, when a hearing will be expedited and the interest of the parties will not be prejudiced substantially, any part of the evidence may be received in written form.
- 19.8.3.7 The Hearing Officer(s) may issue subpoenas to compel attendance of any person at the hearing, and require the production of books containing compliance violation notices, records and other documents material to a hearing.
- 19.8.3.8 The Hearing Officer(s) may inquire of any witness following any segment of testimony.
- 19.8.3.9 Members of the public may testify in cases before the Hearing Officer(s).
- 19.8.3.10 All testimony shall be recorded verbatim, by human or electronic means. Any party requesting a transcript of any oral proceeding, or any part thereof, shall pay the cost thereof.

- 19.8.4 Upon the Hearing Officer(s) finding a violation has occurred, the Hearing Officer(s) shall levy such penalty, and require corrective action as he deems appropriate to the violation, subject to the following penalties per NRS 444.635:
- 19.8.4.1 For a first offense, at least \$500 but not more than \$5,000, per day;
 - 19.8.4.2 For a second offense, at least \$1,000 but not more than \$5,500, per day;
 - 19.8.4.3 For a third offense, at least \$1,500 but not more than \$6,000, per day;
 - 19.8.4.4 For any subsequent offense, at least \$500 more than the most recent previous penalty levied by the Hearing Officer, per day.
- 19.8.5 Factors to be considered by the Hearing Officer(s) in determining the amount of any penalty imposed pursuant to section **19.8.4** herein includes but are not limited to the following:
- 19.8.5.1 Failure to respond to compliance notices within the time (s) specified.
 - 19.8.5.2 Gravity of the violation.
 - 19.8.5.3 Environmental impact.
 - 19.8.5.4 Public health impact.
- 19.8.6 The decision of the Hearing Officer(s) must be reduced to writing and shall be final 10 days after mailing to by certified mail, return receipt requested or personal service upon each party.
- 19.8.7 All penalties levied by the Hearing Officer(s) shall be paid to the Health District, and used only to pay for management of the Individual Sewage Disposal Systems program within the jurisdiction of the Environmental Health Division.
- 19.8.8 Failure to comply with any order of the Hearing Officer(s) requiring corrective action constitutes a separate violation of these regulations, and subjects the responsible party to additional cases of alleged violations with separate and additional penalties thereof.
- 19.8.9 Any party aggrieved by a decision of the Hearing Officer(s) may seek judicial review of the decision of the Hearing Officer(s), in accordance with the provisions of NRS 233B.130(2), and NRS 233B.131 through 233B.150, inclusive.

Section 20

INTERPRETATION AND SEVERABILITY

Where the context as requires, in interpreting these Regulations, the singular shall include the plural, the singular, the masculine gender and the feminine gender. Should any provision of these Regulations be held invalid or unconstitutional, such invalidity or unconstitutionality shall not affect the remaining provisions, and to this end the provisions hereof are declared to be severable. Paragraph headings are intended for convenience of identification only, and not as an aid to interpretation.

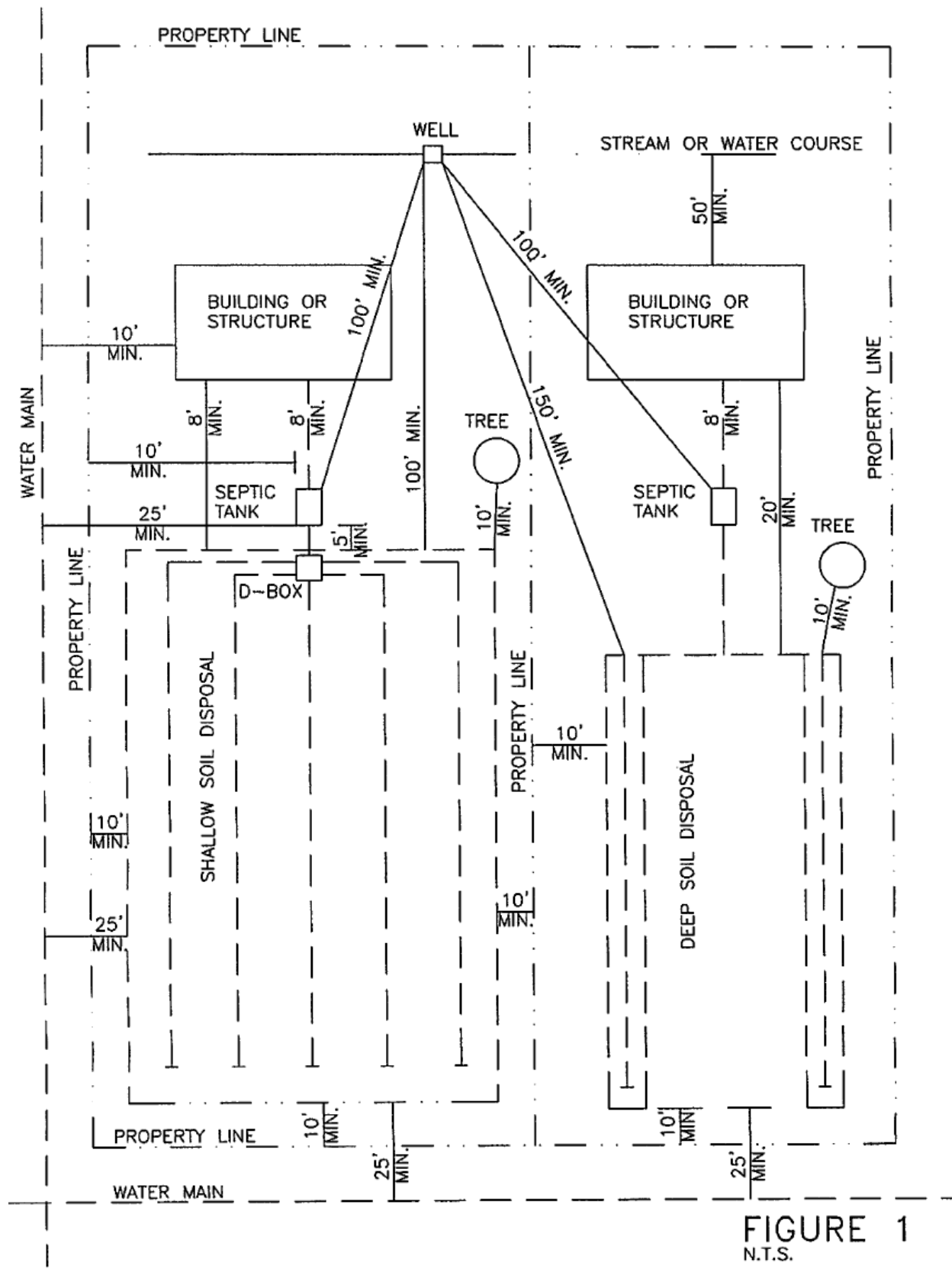
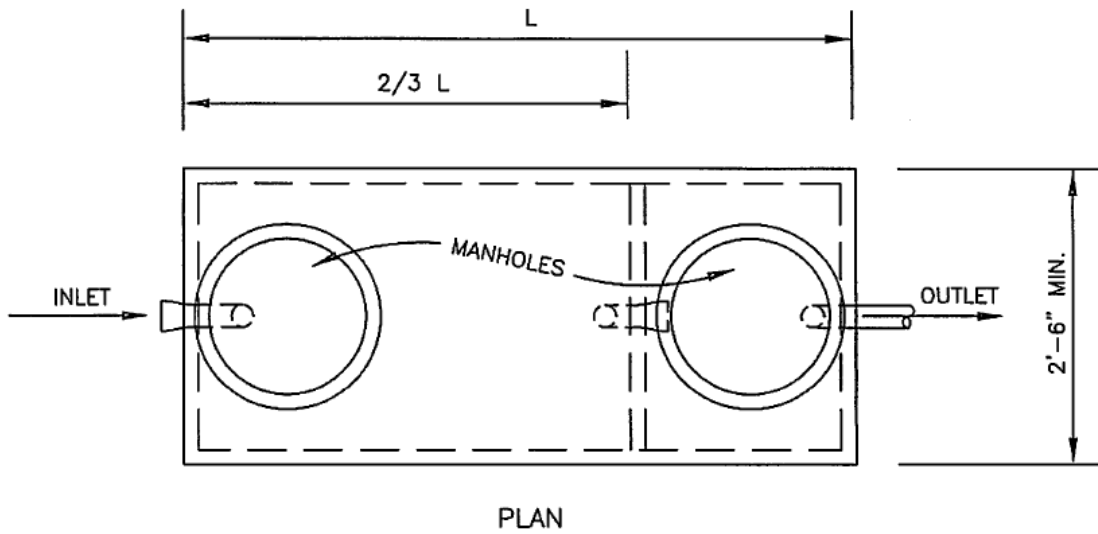
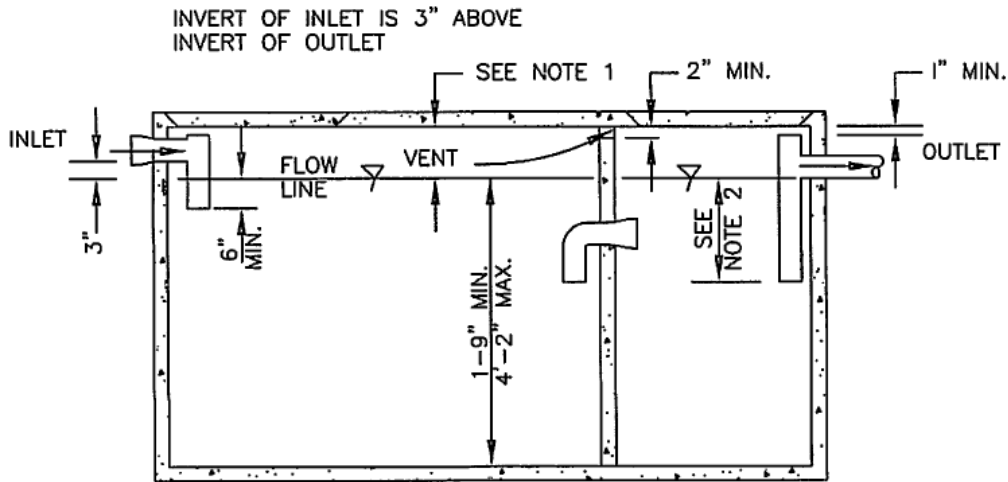

FIGURE 1
N.T.S.



NOTE: SEE REGULATIONS FOR
CONCRETE THICKNESS
AND REINFORCEMENT



LONGITUDINAL SECTION

- NOTES:
1. 9" OR 20% OF TOTAL LIQUID DEPTH
2. 40% OF TOTAL LIQUID DEPTH

TWO COMPARTMENT SEPTIC TANK
N.T.S.

FIGURE 2

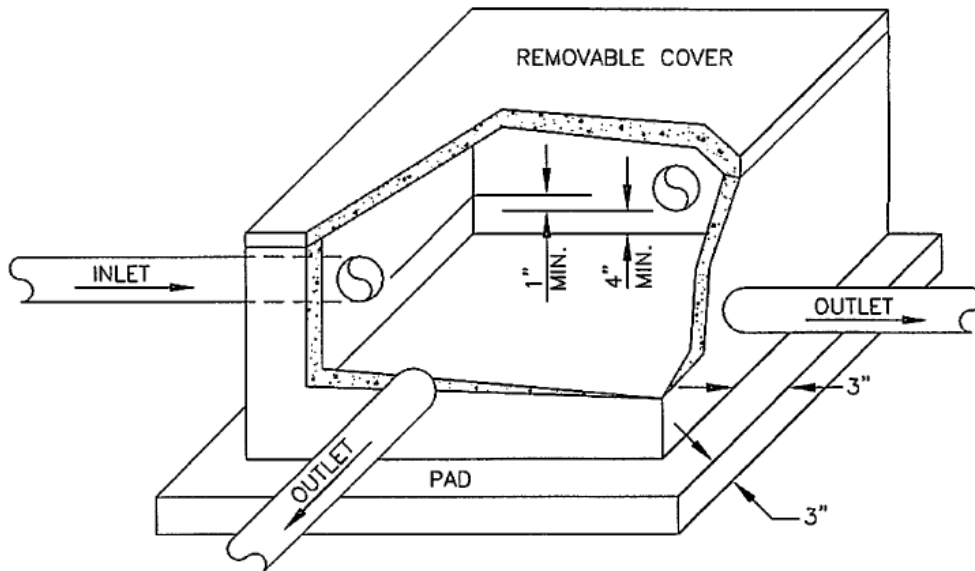
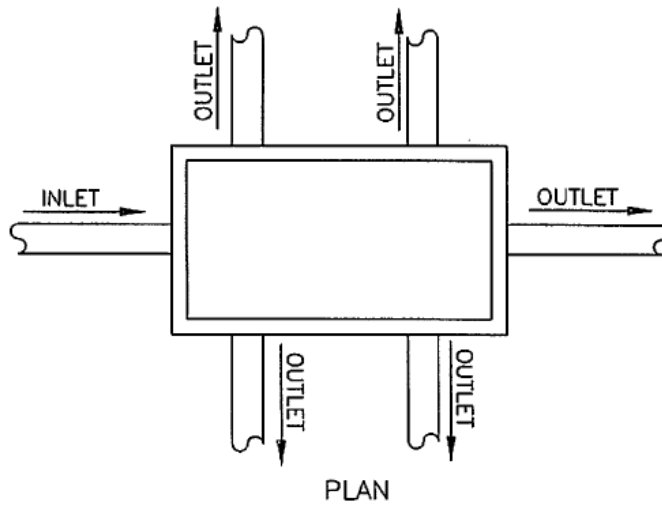

NOTES:

1. ALL OUTLET INVERTS ARE TO BE LEVEL AND FROM 4" TO 6" ABOVE THE FLOOR OF THE BOX.
2. INLET INVERT HEIGHT IS TO BE 1" MIN. ABOVE OULET INVERTS.
3. EACH FIELD LATERAL IS TO BE CONNECTED INDIVIDUALLY TO THE DISTRIBUTION BOX AND IS NOT TO BE SUBDIVIDED.

DISTRIBUTION BOX DETAIL
N.T.S. FIGURE 3

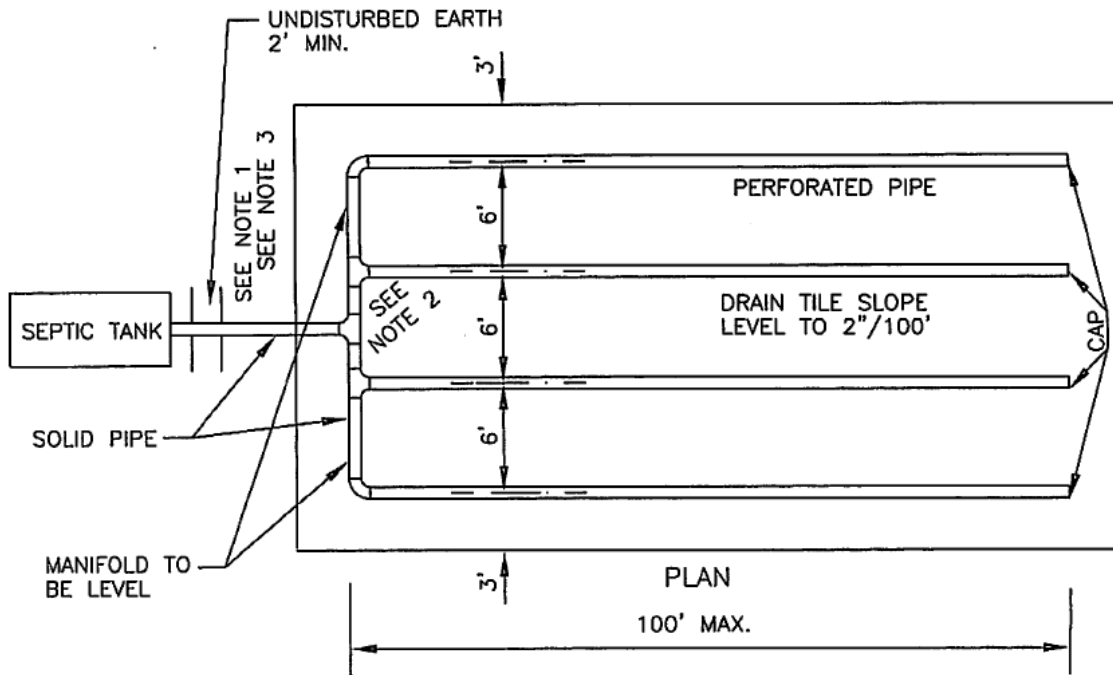

- NOTES:
1. WIDTH OF BED IN MULTIPLES OF 6'
 2. D-BOX IS REQUIRED WHEN VOLUME OF SEPTIC TANK GREATER THAN 2000 GALLONS OR IF THERE ARE AN ODD NUMBER OF LINES
 3. 5' MIN. BETWEEN THE SEPTIC TANK AND LEACH FIELD

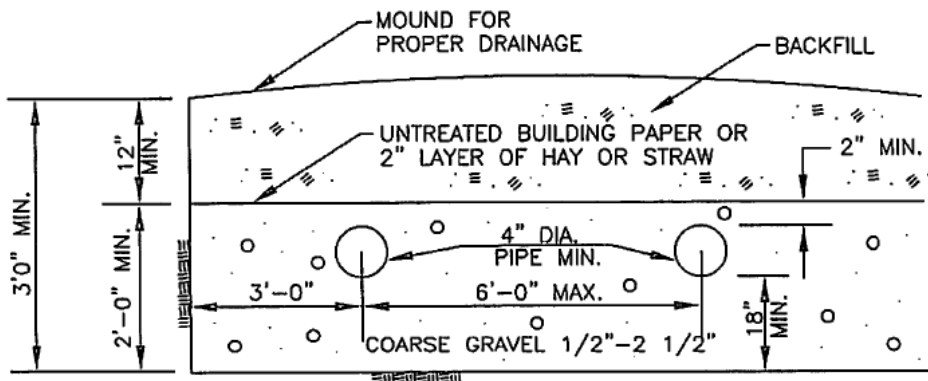

SECTION

TYPICAL SEEPAGE BED
PIPE AND GRAVEL SYSTEM
N.T.S.

FIGURE 4

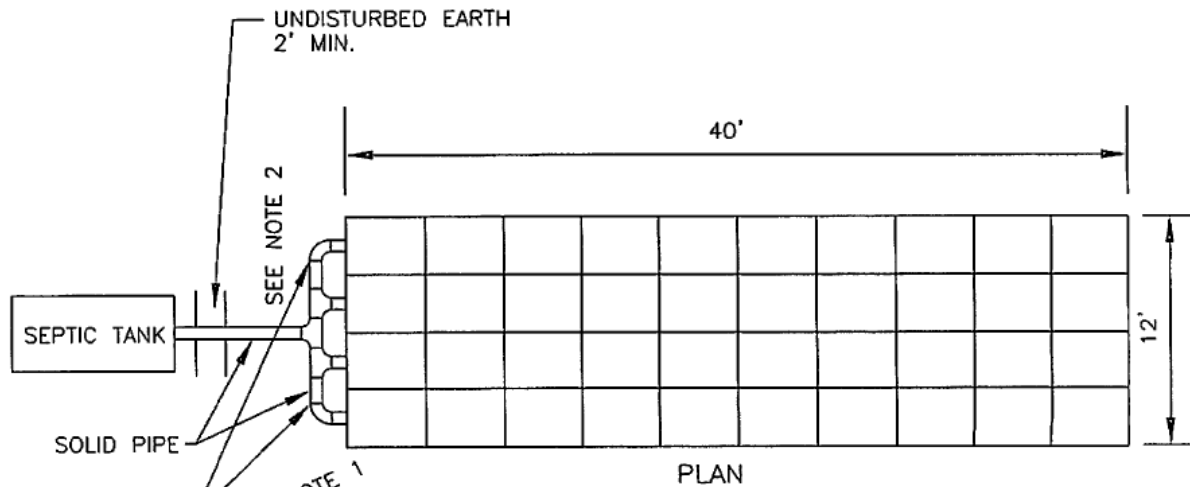

NOTES:

1. D-BOX IS REQUIRED FOR VOLUME OF SEPTIC TANK GREATER THAN 2000 GALLONS OR IF THERE ARE AN ODD NUMBER OF LINES
2. 5' MIN. BETWEEN THE SEPTIC TANK AND LEACH FIELD

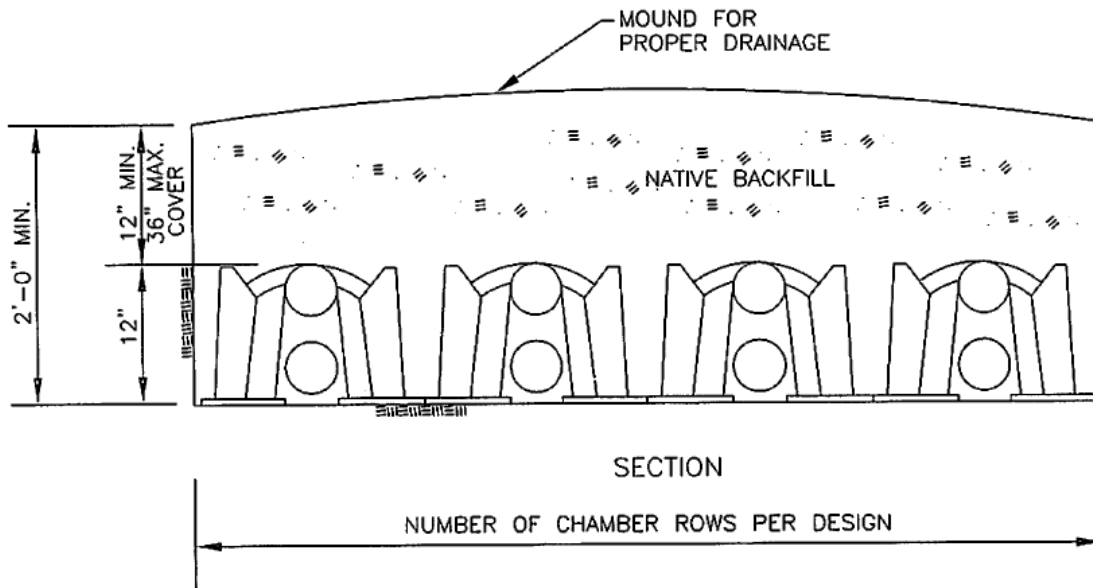

TYPICAL SEEPAGE BED
 CHAMBER SYSTEM
 N.T.S. FIGURE 5

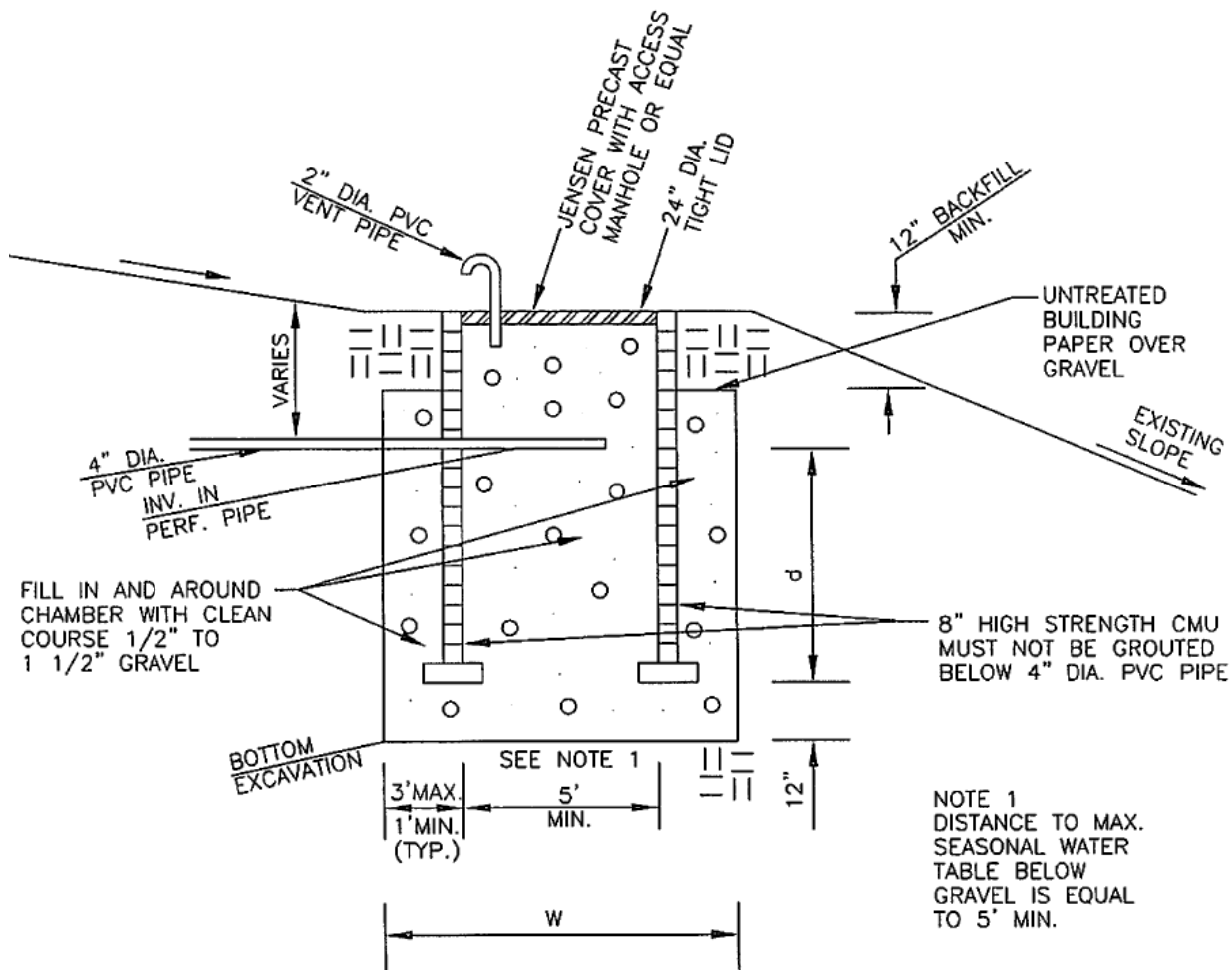

$ABSORPTION\ AREA = 2dW + 2dL$
 $d < W\ OR\ L$
 $d = \text{EFFECTIVE DEPTH BELOW 4" DIA. PIPE}$
 $W = \text{WIDTH OF PIT}$
 $L = \text{LENGTH OF PIT}$

RECTANGULAR LEACH PIT

N.T.S.

FIGURE 6

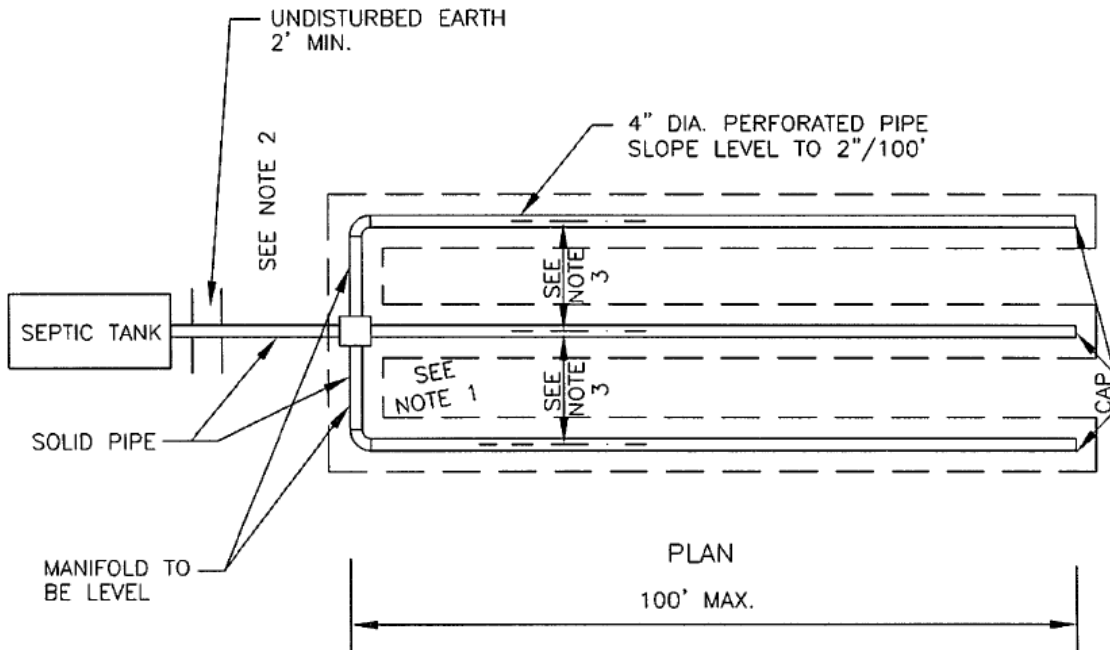

SCHEDULE

DEPTH "D" BELOW PIPE	MIN. DIST. BETWEEN TRENCH SIDEWALLS
18" - 23"	6' - 7'
24" - 29"	7' - 8'
30" - 36"	8' - 9'

1. D-BOX IS REQUIRED WHEN VOLUME OF SEPTIC TANK GREATER THAN 2000 GALLONS OR IF THERE ARE AN ODD NUMBER OF LINES
2. 5' MIN. BETWEEN THE SEPTIC TANK AND LEACH FIELD
3. DISTANCE BETWEEN TRENCHES VARIES, SEE SCHEDULE BELOW

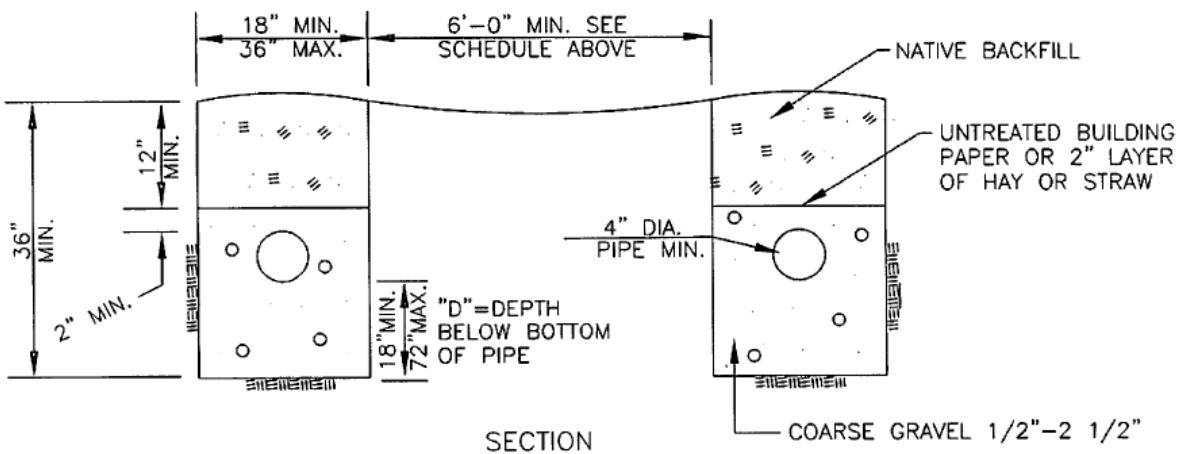

ABSORPTION TRENCH

N.T.S.

FIGURE 7

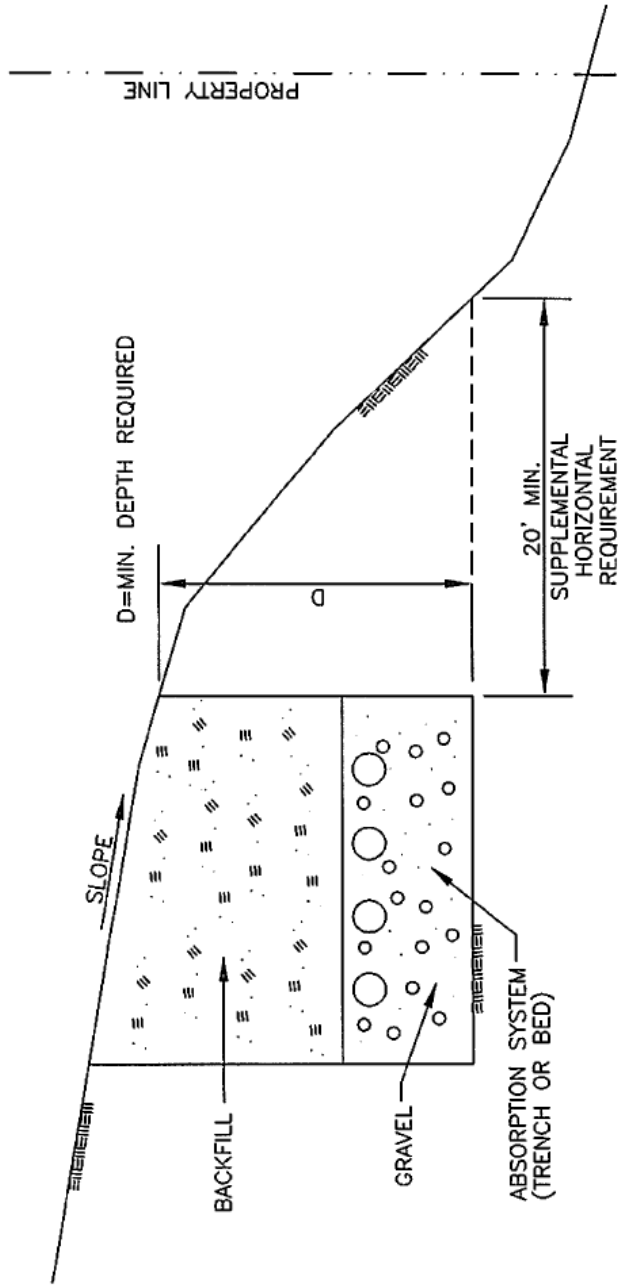

* FOR SLOPES GREATER THAN 20%
 USE EQUATION $D = 10 \times \text{SLOPE} + 3'$

EXAMPLE
 IF $S = 27\%$ THEN $D = 10 \times 0.27 + 3' = 5.7 \text{ FEET}$

FIGURE 8

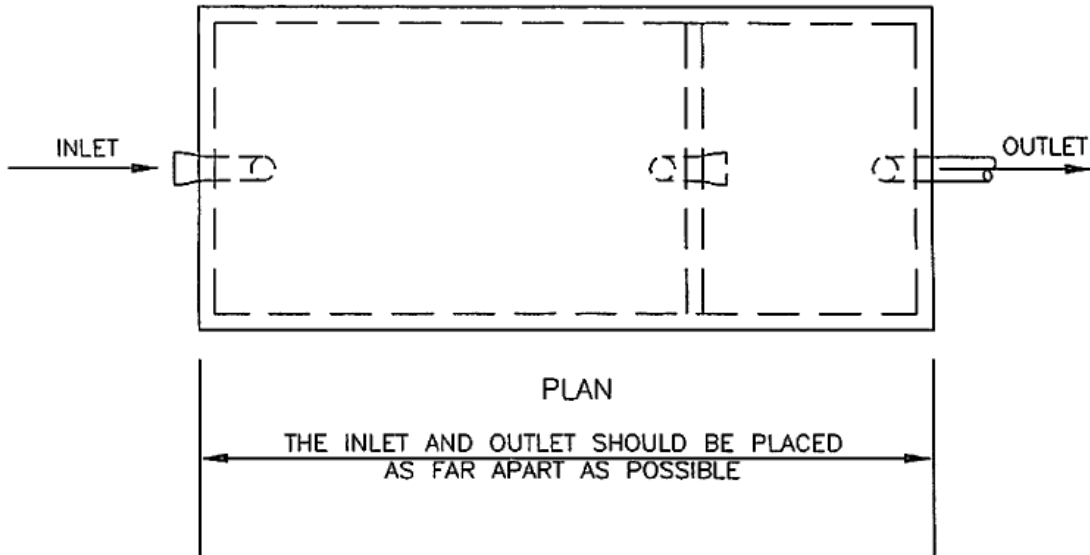

INVERT OF INLET IS 3" ABOVE
INVERT OF OUTLET

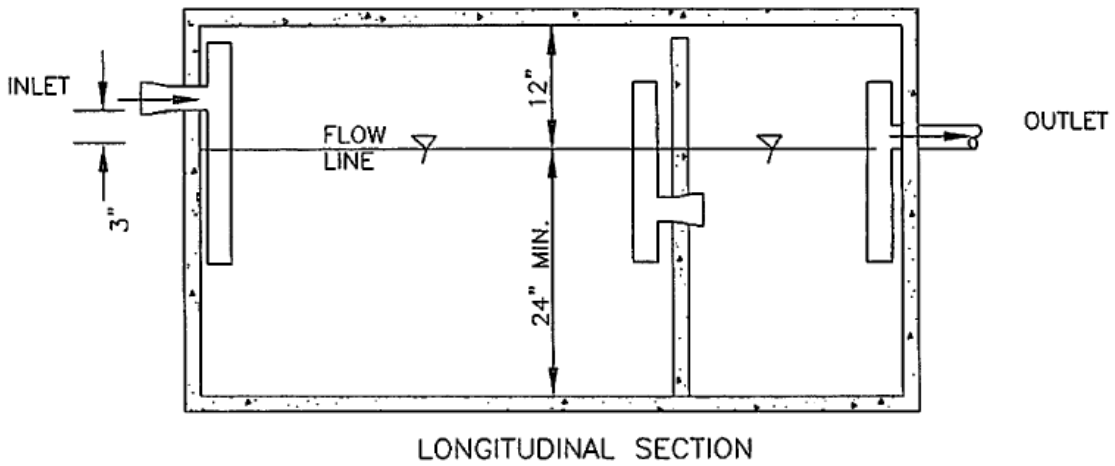

GREASE INTERCEPTOR

N.T.S.

FIGURE 9

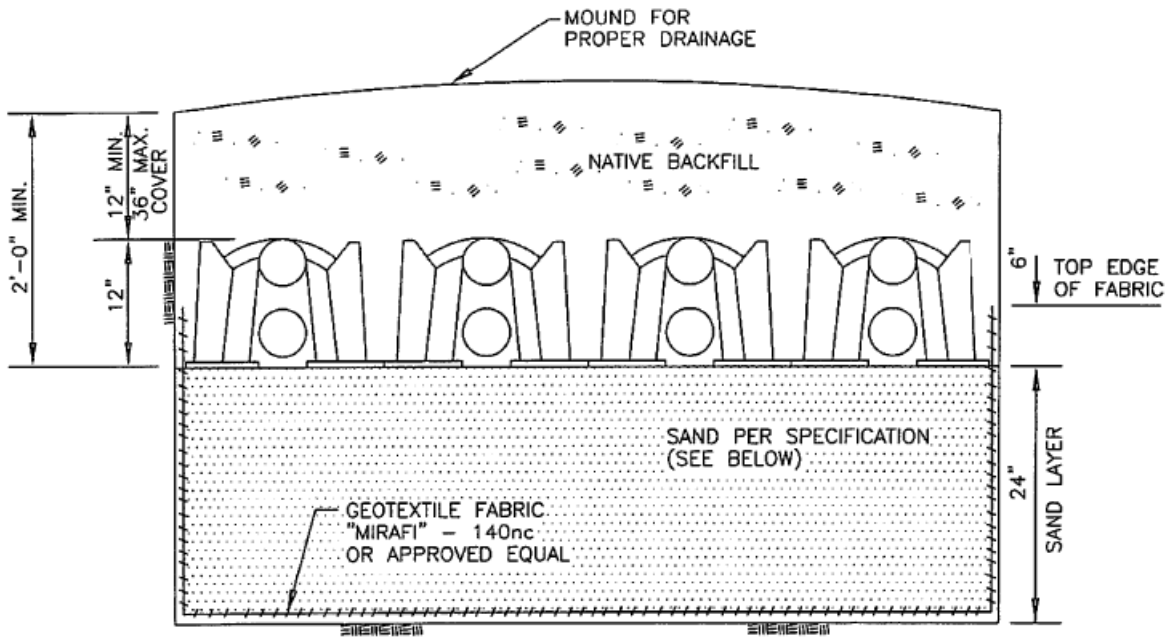

END VIEW

SAND SPECIFICATION - BELOW CHAMBER BED PLACE A TWO (2) FOOT THICK LAYER OF A FINE SAND OR A LOAMY SAND WITH THE FOLLOWING GRADATION AND REQUIREMENTS:

SIEVE SIZE	PERCENTAGE BY WEIGHT PASSING
3/8"	100%
No. 4	80 - 100%
No. 200	0 - 5%

THE PLASTICITY INDEX SHALL NOT EXCEED 9. THE SOLUBLE SULFATE CONTENT SHALL NOT EXCEED 0.3% BY DRY WEIGHT. THE UNIFORMITY COEFFICIENT SHALL BE LESS THAN 4. THE INFILTRATION RATE SHALL BE BETWEEN 1.5 GPD/SF AND 2.5 GPD/SF.

SAND LAYER DETAIL

CHAMBER SYSTEM

N.T.S.

FIGURE 10

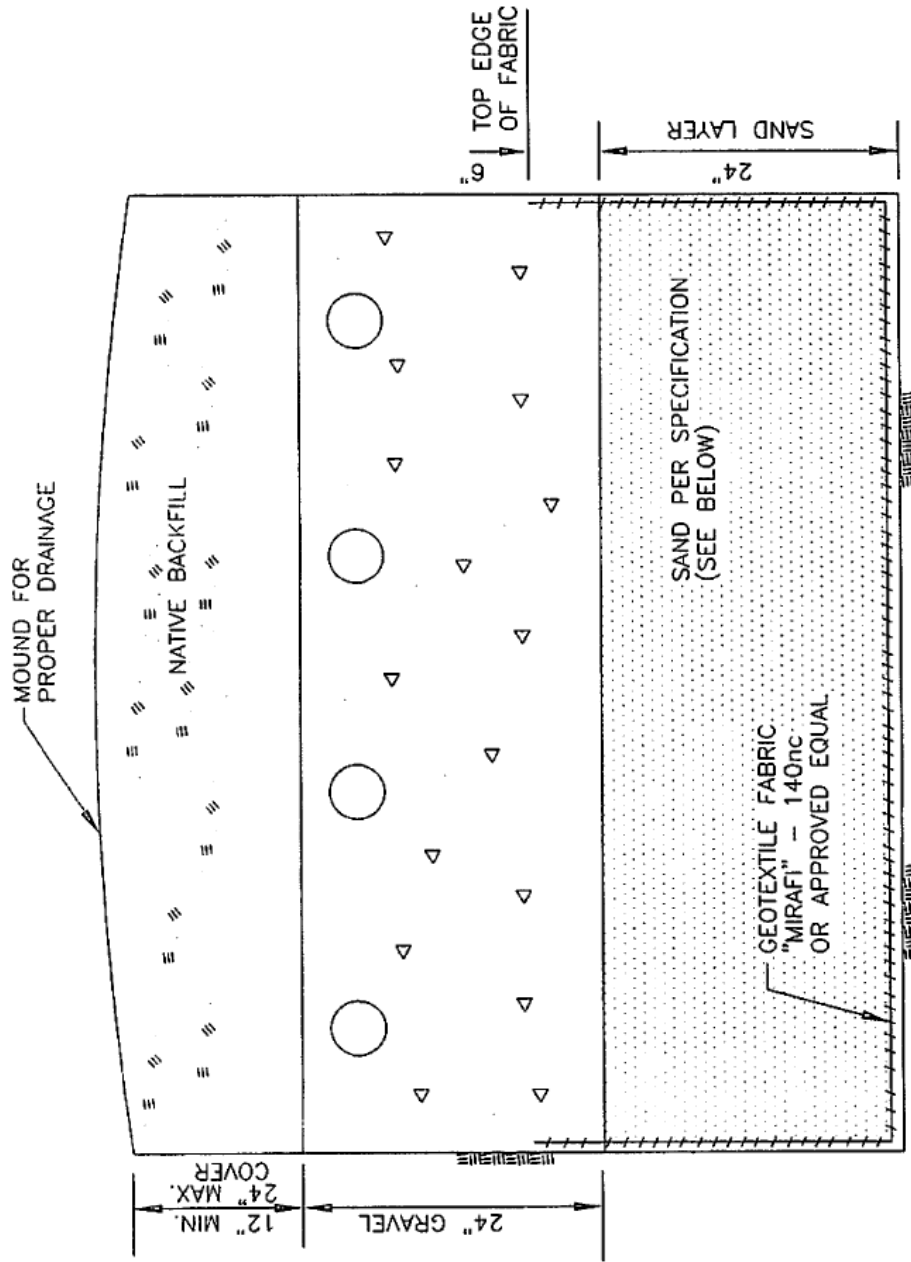

END VIEW

SIEVE SIZE	PERCENTAGE BY WEIGHT PASSING
3/8"	100%
No. 4	80 - 100%
No. 200	0 - 5%

THE PLASTICITY INDEX SHALL NOT EXCEED 9. THE SOLUBLE SULFATE CONTENT SHALL NOT EXCEED 0.3% BY DRY WEIGHT. THE UNIFORMITY COEFFICIENT SHALL BE LESS THAN 4. THE INFILTRATION RATE SHALL BE BETWEEN 1.5 GPD/SF AND 2.5 GPD/SF.

SAND SPECIFICATION - BELOW GRAVEL PLACE A TWO (2) FOOT THICK LAYER OF A FINE SAND OR A LOAMY SAND WITH THE FOLLOWING GRADATION AND REQUIREMENTS:

SAND LAYER DETAIL
 PIPE AND GRAVEL SYSTEM
 N.T.S. FIGURE 10A

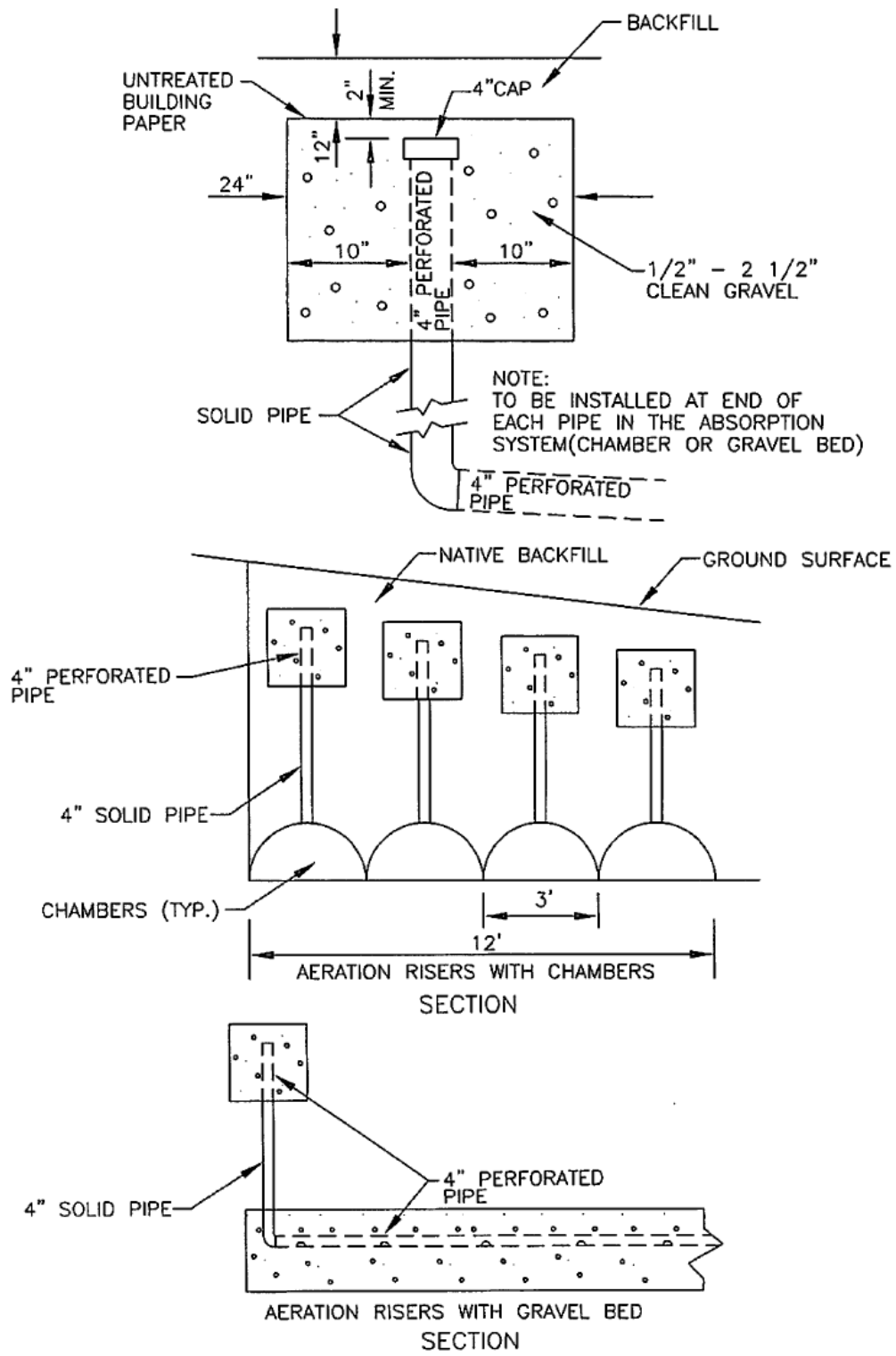

AERATION RISER DETAILS
 N.T.S. FIGURE 11

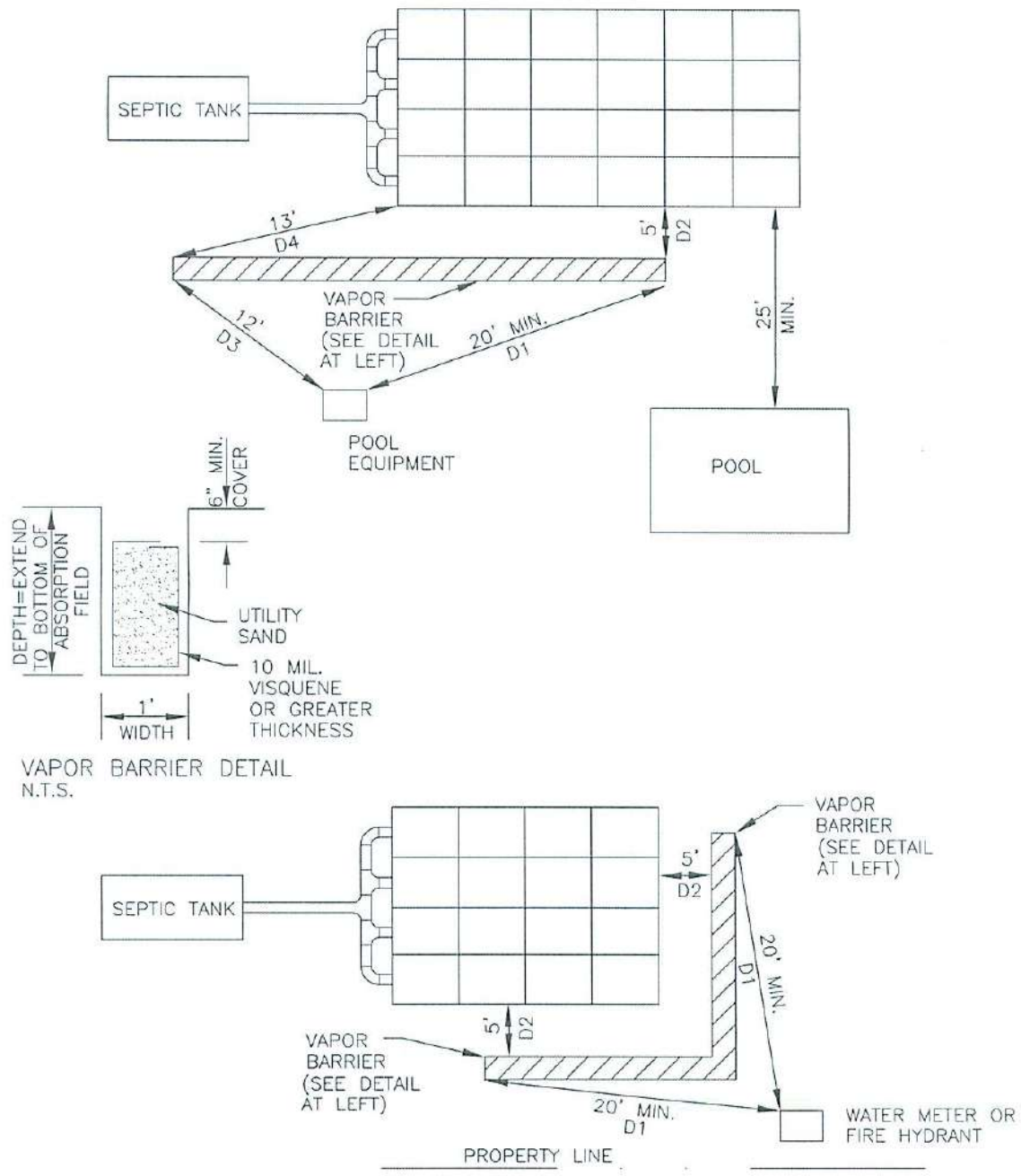

VAPOR BARRIER DETAILS
 N.T.S. FIGURE 12

LEACH FIELD AREA REQUIREMENTS (IN SQUARE FEET)

MAX. FIXTURE UNITS SERVED	MIN. SEPTIC TANK CAPACITY (GALLONS)	PERCOLATION RATE (MIN/INCH)								
		3	4	5	10	15	30	45	60	
0-20	1000	A	350	400	450	635	775	1100	1345	1550
		B	245	280	315	445	545	770	940	1085
		C	(21)	(24)	(27)	(38)	(46)	(65)	(79)	(91)
		D	(13)	(15)	(17)	(24)	(29)	(41)	(50)	(58)
21-25	1200	A	420	480	540	760	935	1315	1610	1860
		B	300	335	380	530	655	920	1130	1300
		C	(25)	(28)	(32)	(45)	(55)	(77)	(95)	(109)
		D	(16)	(18)	(20)	(28)	(35)	(49)	(60)	(69)
26-35	1500	A	520	600	710	950	1165	1645	2015	2325
		B	355	420	500	665	815	1150	1410	1630
		C	(30)	(35)	(42)	(56)	(68)	(96)	(118)	(136)
		D	(19)	(22)	(27)	(35)	(43)	(61)	(75)	(87)
36-45	2000	A	700	800	900	1272	1550	2200	2690	3100
		B	490	560	630	890	1085	1540	1885	2170
		C	(41)	(47)	(53)	(75)	(91)	(129)	(158)	(181)
		D	(26)	(30)	(34)	(47)	(58)	(82)	(100)	(116)
46-55	2250	A	788	900	1013	1429	1744	2475	3027	3488
		B	552	630	709	1000	1220	1722	2118	2442
		C	(46)	(53)	(59)	(83)	(102)	(144)	(177)	(204)
		D	(29)	(34)	(38)	(53)	(65)	(92)	(113)	(130)
56-60	2500	A	875	1000	1125	1588	1940	2750	3363	3875
		B	613	700	788	1112	1360	1925	2354	2715
		C	(51)	(59)	(66)	(93)	(114)	(160)	(196)	(227)
		D	(33)	(37)	(42)	(59)	(72)	(103)	(126)	(145)
61-70	2750	A	963	1100	1238	1747	2132	3025	3699	4263
		B	674	770	867	1223	1492	2118	2589	2984
		C	(56)	(64)	(72)	(102)	(124)	(177)	(216)	(248)
		D	(36)	(41)	(46)	(65)	(80)	(113)	(138)	(159)
71-80	3000	A	1050	1200	1350	1905	2325	3300	4035	4650
		B	735	840	945	1334	1628	2310	2825	3255
		C	(61)	(70)	(78)	(111)	(135)	(192)	(235)	(271)
		D	(39)	(47)	(53)	(74)	(91)	(129)	(157)	(181)
81-90	3250	A	1138	1300	1463	2064	2519	3575	4371	
		B	797	910	1024	1445	1763	2503	3060	
		C	(66)	(75)	(85)	(120)	(146)	(177)	(216)	
		D	(42)	(49)	(55)	(77)	(94)	(133)	(163)	
91-100	3500	A	1225	1400	1575	2223	2713	3850	4708	
		B	858	980	1103	1556	1899	2695	3296	
		C	(71)	(81)	(91)	(129)	(158)	(224)	(274)	
		D	(46)	(52)	(59)	(83)	(101)	(144)	(176)	

A=LEACHFIELD AREA REQUIREMENT FOR A PIPE AND GRAVEL SYSTEM
 B=LEACHFIELD AREA REQUIREMENT FOR A CHAMBER SYSTEM
 C=MINIMUM NUMBER OF CHAMBERS 3'WIDE x 4'LONG
 D=MINIMUM NUMBER OF CHAMBERS 3'WIDE x 6.25'LONG

LEACH FIELD AREA REQUIREMENTS

N.T.S.

FIGURE 13





STATE OF NEVADA
Department of Conservation & Natural Resources
DIVISION OF ENVIRONMENTAL PROTECTION

Jim Gibbons, Governor
Allen Biaggi, Director
Leo M. Drozdoff, P.E., Administrator

**MEMORANDUM OF AGREEMENT BETWEEN THE
NEVADA DIVISION OF ENVIRONMENTAL PROTECTION
AND THE SOUTHERN NEVADA HEALTH DISTRICT**

The Southern Nevada Health District, hereinafter referred to as the "SNHD", and the Nevada Division of Environmental Protection, hereinafter referred to as "NDEP" enter into this Memorandum of Agreement (MOA) with the purpose to provide a transfer of jurisdiction for the Onsite Sewage Disposal System (OSDS) program from NDEP to SNHD as described in NAC445A. Under this MOA, the OSDS program within Clark County will be administered by the SNHD under the following conditions:

1. This Memorandum of Agreement applies only to OSDS and Holding Tanks systems within Clark County starting on November 4, 2008.
2. After review by coordination with NDEP, SNHD will adopt NDEP Regulations for Onsite Sewage Disposal Systems by reference.
3. SNHD will review, approve and permit Onsite Sewage Disposal Systems (OSDS) with total volume capacity of 3,000 gallons or less. Holding tanks also be permitted by SNHD.
4. SNHD may review, approve and permit OSDS systems above a 3,000 gallon capacity at NDEP's discretion. Some monitoring & inventory requirements may apply.
5. SNHD will not permit any wastewater treatment systems which may have industrial waste.
6. SNHD will take immediate steps to abate and resolve any health hazards which may happen as a result of OSDS failures. SNHD will inform NDEP on all discharge permit violations for which corrective or enforcement actions are taken.
7. NDEP retains the authority to regulate Clark County's OSDS program upon a 90 day notification process.

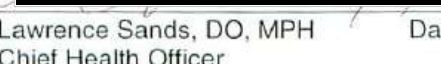

 Leo Drozdoff, P.E. 11/6/08
 Administrator Date
 Nevada Division of Environmental Protection



 Lawrence Sands, DO, MPH Date
 Chief Health Officer
 Southern Nevada Health District

