

This paper was first presented by Terry R. Bounds, PE., at the 1997 conference of the American Society for Testing and Materials, in Philadelphia, Pennsylvania. This article may describe design criteria that was in effect at the time the article was written. FOR CURRENT DESIGN CRITERIA, call Orenco Systems, Inc. at 1-800-348-9843.

Design and Performance of Septic Tanks

T.R. Bounds, P. E.¹

Reference

Bounds, T.R., “**Design and Performance of Septic Tanks,**” Site Characterization and Design of Onsite Septic Systems ASTM STP 901, M.S. Bedinger, A.I. Johnson, and J.S. Fleming, Eds., American Society for Testing Materials, Philadelphia, 1997.

Abstract

More than forty million people in the United States currently use onsite wastewater disposal or decentralized sewerage collection and treatment that rely on septic tanks for primary treatment. There is a good reason why, in this age of advanced technology, the septic tank is still in use. It works. More than 45% of ultimate treatment can be accomplished in the septic tank. Advanced onsite and effluent sewer technologies have established their environmental importance by bringing highly reliable, affordable and permanent wastewater treatment to users worldwide. In short, passive—energy free—septic tanks provide the most cost efficient form of primary treatment available for nonindustrial sewage.

Decentralized sewers and onsite alternatives have advanced us to a new era of wastewater treatment and management where designers must be able to rely on the many essential components of the system. System components must be designed and constructed with the same permanency and quality expected of any long-term option. Because the septic tank is an essential ingredient to the success of these systems, a new generation of structurally-sound, watertight septic tanks is evolving.

Keywords

septic tanks, septage, structural adequacy, watertightness, biochemical, pumping interval, frequency, accumulation rates, retention time

The Septic Tank

The septic tank is an enclosed receptacle designed to collect wastewater, segregate settleable and floatable solids (*sludge and scum*), accumulate, consolidate and store solids, digest organic matter and discharge treated effluent. Currently more than one-third of the nation’s wastewater treatment is provided by septic tank systems. The septic tank may be the single most important component used in all onsite treatment and collection alternatives.

¹T. R. Bounds, P.E., E.Vice President, Orenco Systems, Inc., 814 Airway Ave., Sutherlin, Oregon 97479

Usage

The most common usage is in rural residential applications. Besides its role in standard subsurface soil absorption systems, the pre-treatment provided by the septic tank is equally important in ensuring the success of other secondary treatment alternatives such as constructed wetlands, ponds, intermittent and recirculating sand filters, peat filters, mound systems, synthetic filters or membrane systems, up-flow filters, pressure distribution systems, and nitrogen reduction systems. In addition, septic tank pre-treatment often precedes packaged aerobic treatment processes (see Figure 1). Multiple tanks are often used in parallel or series configurations when greater treatment, storage or surge capacity is necessary.

The septic tank is also a major component in pressure and variable grade effluent sewer collection alternatives (*STEP and STEG systems*). The reason is simple: the primary-treated effluent discharged from the septic tank is mild, consistent, easy to convey and easily treated by either aerobic or anaerobic secondary processes.

In this age of advanced technology, there is a good reason why the septic tank is still in use; it works. Passive—energy free—septic tanks provide the most cost efficient method of primary treatment available for nonindustrial sewage; BOD (biochemical oxygen demand) removals of greater than 65 percent and TSS (total suspended solids) removals of greater than 70 percent are easily accomplished (Bitton, 1994).

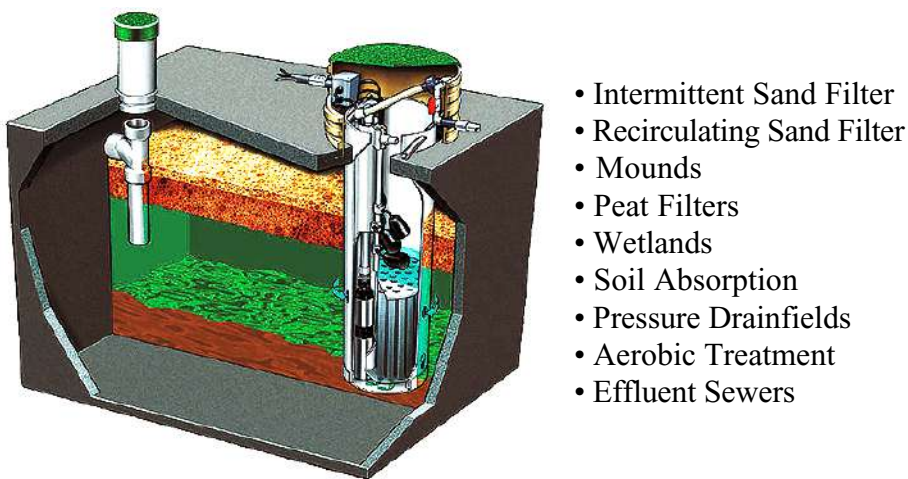

Figure 1: Typical applications that require septic tank pre-treatment.

Unfortunately, the septic tank is often the most disregarded component in the system. The performance and success of a properly sized tank relies on its structurally-adequate, watertight design and construction. If these simple criteria are not met, infiltration or exfiltration will fix the fate of the system.

Septic Tank Biology

Septic tanks are passive low-rate anaerobic digesters, with their own ecosystem, in which facultative and anaerobic organisms perform complex biochemical processes. The tank operates as a plug-flow type of reactor (*fluid and particles enter and exit the tank in progressive sequence*), so there is usually no mixing

or heating, particles ascend or descend and stratification develops. Effluent quality suffers when this stratification doesn't develop. The environment within the tank's clear zone is generally anoxic, or inadequate in oxygen, while sites within the sludge and scum layers may be completely free of oxygen, or anaerobic.

The inflowing wastewater directed into the clear zone (*just beneath the scum layer*) by the inlet fixture normally contains high levels of dissolved oxygen. The microbial population, however, rapidly depletes the dissolved oxygen as the flow disperses in the tank and moves towards the outlet. The bacteria found in residential wastewater are enteric, the same as those found in the gut (Ziebell et al. 1974). These organisms are primarily heterotrophic bacteria which oxidize and solubilize organic matter. Facultative microbes (*organisms that can function in either aerobic or anaerobic conditions*) solubilize complex organic material to volatile organic acids, while strict anaerobes ferment the volatile organic acids to gases (*methane, carbon dioxide, hydrogen sulfide, etc.*). The microbes use the solubilized nutrients in the wastewater for cell growth and energy. The microbes are enteric, therefore, natural inhabitants of the wastewater, but it takes years to develop volatile organic acid and metabolite concentrations sufficient for colonization of methane formers and optimum digestion. Their population, growth and effectiveness are dependent on the characteristics of the wastewater (*e.g., temperature, organic load, inorganic trash, toxic chemicals or cleaners, excessive fats, oils, grease, detergents, high hydraulic loads, etc.*) as well as the sizing and design features of the tank. Consequently, a tank must be adequately sized for the occupancy usage in order to ensure a long-term quiescent environment for the organisms to colonize. When long-term storage is allowed, the effectiveness of digestion within the layers of stored volatile solids can be as great as 80 percent (Metcalf and Eddy, Inc., 1972), and the microbial population (*biomass*) required to accomplish the feat may range from one-fifth to only one-twentieth of that generated in an equivalent aerobic treatment process (Bitton, 1994).

The dominant bacterial groups measured in the septic tanks by Ziebell et al. in 1974, were total and fecal coliform, fecal streptococci, lactic acid bacteria, anaerobes, and others. The total bacteria population can range up to 230,000,000 per ml (Tyler et al. 1978). Taber (1976) divided the bacteria into two groups, separating the methanogenic bacteria, or methane formers, from the non-methanogenic bacteria. Following are some of the bacteria identified in each group:

The non-methanogenic bacteria include:

Actinomyces, Alcaligenes viscolatis, A. faecalis, Bacillus, Bacteroides, Bifido bacterium, Branhamella catarrhalis, Clostridium, Corynebacterium, Desulfovibrio desulfuricans, E. coli, Eubacterium, Euterobacter atrotenes, Fusobacterium, Lactobacillus, Leptospira biflexa, Micrococcus varians, Micrococcus lateus, Peptococcus, Pseudomonas reptilivora, Ramibacterium, Spirillum, Veillonella, and Vibrio

The methanogenic bacteria include:

Methano bacterium, Methanobacterium formicicum, Methanobacterium ruminatum, Methanospirillum sp., and Methanoccus vanneilli

The digestion that takes place in the tank is performed predominately by bacteria. The most common bacteria shapes are spheres (*coccus*), rods (*bacillus*) and spirals (*spirillum*). These shapes can be observed as individual cells, or they may be seen grouped or linked together. Each organism is

encapsulated by a slime layer of extracellular enzymes. These extracellular enzymes hydrolyze organic material by adding water to the organic molecules, reducing them to simple soluble organic compounds small enough to be absorbed through the cell wall. Inside the cell, intracellular enzymes further metabolize and oxidize the volatile organic molecules creating the energy required for cell growth. Enzymes are complex proteins and can be precipitated, or have their enzyme reactive points tied up, by excessive amounts of salts and heavy metals. Either of these contaminants will inhibit the ability of the microbes to adequately produce their soluble organic nutrition, in effect, retarding the tank's performance. Taking precautions to reduce excessive disposal of household products containing large concentrations of zinc, copper, calcium, magnesium, iron, ammonium sulfate, sodium sulfate, sodium chlorides, etc., is an important first step in assuring natural biochemical processes. Normal or conservative residential uses of salts, bleaches and detergents, however, are not detrimental to the microbial population.

Performance

As the wastewater passes through the tank, its characteristics change and different bacterial cultures predominate as the bacteria break down complex proteins, carbohydrates, and fats. An assortment of typical wastewater characteristics are shown in the following tables. The values shown in Table 1 are averages for wastewater entering the tank (*influent*).

Table 1: Characteristics of Raw Domestic Sewage

Source	Flow <i>L(gal)/capita/day</i>	BOD ₅ <i>mg/l</i>	TSS <i>mg/l</i>	Grease <i>mg/l</i>	pH
Watson et al-Home 1	295 (78)	542	363	95	8
Watson et al-Home 2	250 (66)	284	293	33	8
Watson et al-Home 3	91 (24)	479	473	66	8.3
Watson et al-Home 1	269 (71)	518	478	134	7.6
Watson et al-Home 2	193 (51)	356	360	41	8.2
Watson et al-Home 3	110 (29)	598	602	92	8.4
Kreissl	242 (64)	435	380	65	
Kreissl		490	480	89	
Lawrence-Home 1	117 (31)	241	200	21	7.5
Lawrence-Home 2	185 (49)	146	126	16	7.2
Otis et al.		233	269		
U. Wisconsin	121 (32)	415	296	122	
U. Wisconsin	129 (34)	465	394	129	
U. Wisconsin		343	259		
Bennett, ASAE	168 (45)	278	396		7.4
Carcich et al	121 (32)	330	310	81	7.8
Comm. on Rural Water	220 (58)	207	165		
Schmidt	151 (40)	400			
Bounds, 1982-Grinders	189 (50)	304	226	42	6.9
Metcalf and Eddy, 3rd. Ed.	189 (50)	392	436	70	7.2
Ziebell, 1974		343	259		
Average	179 (47)	371	338	73	

The values shown in Table 2 are averages for non-screened wastewater passing from the tank (*effluent*). Also shown in Table 2 are average strengths for single and multiple compartment tanks.

Table 2: Characteristics of Septic Tank Effluent (*unfiltered*)

Source <i>(compartments)</i>	Flow <i>L(gal)/capita/day</i>	BOD₅ <i>mg/l</i>	TSS <i>mg/l</i>	Grease <i>mg/l</i>	pH
Kreissl	242 (64)	218	114		
Lawrence-Home 1	117 (31)	224	130	26	7.5
Lawrence-Home 2	185 (49)	124	70	8.5	7.2
Otis et al		125	60		
Otis et al		130	40		
U. Wisconsin		158	51		
Bennett, ASAE		134			
Schmidt-(two)	151 (40)	90			7.1
Bounds, 1982-STEP-(one)	189 (50)	118	52	16	6.9
PHS 2nd Series		178	111		7.4
PHS 3rd Series		92	112	19	7.5
PHS 4th Series		151	128		7.5
Barshied		223	39		7.1
Ronayne, 1982-(two)	208 (55)	217	146		
USEPA 1980 On-Site	167 (44)	155	88		
Ziebell, 1974		158	51		
Eastsound, WA, <i>Bounds 1996</i>		214	117		
Loon Lake, WA, <i>Bounds 1996</i>		90	45		
Cagle, 1993, Placer, CA-(two)		160	73		
Average	180 (48)	156	84	17	

The values shown in Table 3 are averages for effluent passing from the tanks equipped with screened vault dosing assemblies. The data shown are from community effluent collection systems, nearly all of which have restaurants, schools and other commercial establishments in addition to residential connections.

Table 3: Characteristics of Screened STEP and STEG Effluent

Source	Installed	EDUs^a	Flow <i>L(gal)/capita/day</i>	BOD₅ <i>mg/l</i>	TSS <i>mg/l</i>
Gala Manor, CA	1991	100		200	22
Penn Valley, CA	1989	376	144 (38)	129	28
West Point, CA	1986	165	265 (70)	136	32
Ball, OR	1992	1	246 (65)	125	28
Brooks, OR	1991	318		111	37
Elkton, OR	1989	135	159 (42)	136	32
Irrigon, OR	1989	446	314 (83)	93	35
Lapine, OR	1988	205		103	
Tangent, OR	1987	230		110	27
Boston Harbor, WA	1989	182		164	34
Camas, WA	1989	1070		108	35
Montesano, WA	1989	1500		160	30
South Prairie, WA	1992	136		210	37
Stuth (Aqua Test), WA	1992	1		70	15
Average			226 (60)	133	30

a. Number of Equivalent Dwelling Unit based on the flow from an average single family dwelling with 3 occupants (150 gpd/EDU).

The values shown in Table 4 are averages of various other septic tank effluent characteristics taken from the Glide, Oregon, Pressure Sewer Wastewater Characteristics report (Bounds 1982).

Table 4: Septic Tank Effluent Characteristic from Glide, OR

Characteristic	Range	Mean
Alkalinity, mg/l	200-335	246
TSS, mg/l	17-130	52
VSS, mg/l	13-114	40
Grease, mg/l	6-59	16
pH	6.4-7.3	7.2
Temperatures, °C	10-23	16.1
SO ₄ , mg/l	31-74	43
Na, mg/l	59-99	79
Mg, mg/l	4.7-26	15.4
Ca, mg/l	3-13	8
Ortho/Poly PO ₄ , mg/l	8.8-15	12
PO ₄ , mg/l	9.5-12	11
TKN-N, mg/l	40-58	50
NH ₃ -N, mg/l	10.5-48	31.5

The difference between the average values of Tables 1 and 2 shows that 58 percent reduction in BOD₅, 75 percent reduction in TSS and 77 percent reduction in oil and grease occurs as the wastewater passes through the tanks.

The difference between the average values of Tables 1 and 3 are an indication that a 64 percent reduction in BOD₅ and 91 percent reduction in TSS occurs with the addition of filtering devices. The addition of effluent filters significantly reduced the TSS in wastewater passing through the tanks. This reduction accomplished by a configuration designed to mitigate solids floated by gas ebullition and to retain coarse solids. Filters should be sized and configured so that cleaning is required no more often than every five to ten years.

Good segregation and digestion is expected to reduce the total suspended solids by 80 to 90 percent and the biochemical oxygen demand by 60 to 70 percent. The organic (*volatile*) solids in the influent may vary from 40 to 70 percent; the mineral or inorganic (*fixed*) solids content, therefore, may range from 30 and 60 percent of the total solids. If solids discharged into tanks are *well managed*, the inorganic concentration will be reduced considerably. Depending on how well educated the users become regarding proper disposal practices and general care of their system, the digestible solid concentration could reach 80 percent.

Septic tank flora are very complex. For performance to be better understood and optimized, more in-depth and thorough research is necessary.

Septic Tank Design

Defining the Tank

Illustrated in figure 2 is a concrete septic tank typical of the type used in onsite disposal systems and in effluent sewers. The designation, 3785 L (*1000 gal*) to 5678 L (*1500 gal*), is nominal and refers to the

volume normally occupied by the tank's contents, not including the reserve space. Total volume is usually 15 to 20 percent greater.

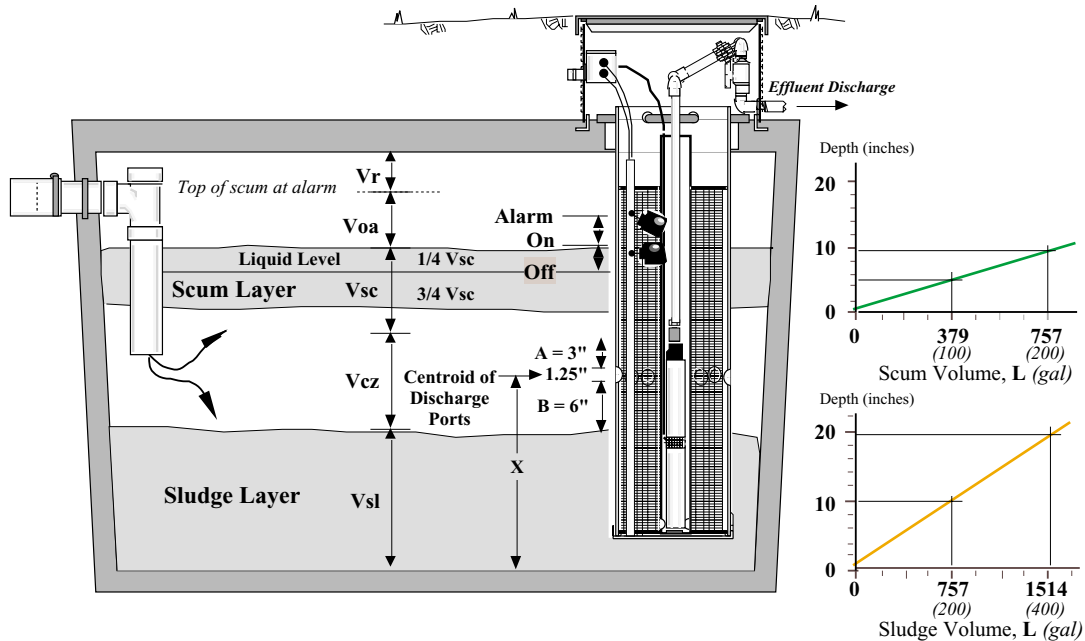

Figure 2: Typical 3785 L (1000 gal) concrete dosing septic tank

Tanks that are properly sized and constructed provide highly efficient treatment capable of yielding effluent that is relatively free of fats, oils, greases, solids and other constituents that can clog and foul collection and disposal equipment. Proper sizing is required to ensure adequate volume is available for development of the necessary microbial environments. Also vital to performance are the tank's structural-soundness and watertightness. These ingredients are essential to the success of every system (*no exceptions*) and should be strictly enforced in all applications, not just within management district boundaries. Methods are presented here to enable designers, regulators, and operations personnel to size tanks relative to occupancy loading, to achieve adequate hydraulic retention times for settlement of solids, to determine a tank's optimum effluent withdrawal level, and to predict septage pumping intervals.

Wastewater flows for single-family dwellings typically range from 151 to 227 litres per capita per day (Lpcd) (*40 to 60 gallons per capita per day (gpcd)*); 189 Lpcd (*50 gpcd*) is a commonly-used design parameter and is the value used in calculations herein. The number of individuals (capita) is assumed to average three per dwelling.

To ensure sufficient capacity each tank must meet these requirements:

- 1) Provide **reserve space** adequate for 24 to 48 hours of normal use, in case of malfunction, before repairs must be made. The reserve space (V_r) is that portion of the tank from the soffit to the top of the scum layer when the liquid level is at the alarm stage. The reserve storage capacity is normally the product of the number of occupants and the average daily flow per occupant—757 L

(200 gal) is usually sufficient for most three and four bedroom homes. The reserve space also allows for adequate ventilation back through the inlet plumbing.

- 2) Provide an **operating zone** sufficient to modulate or surge peak inflows without causing nuisance alarms or excessive hydraulic gradients. The operating zone (V_{oa}) is that portion of the tank between the “off” level and the “high-water alarm” level. Keeping this zone small has the advantage of maximizing sludge and scum storage volume and minimizing disturbance of the scum layer during pumping cycles. Dosing septic tanks may operate at a lower liquid level than tanks that discharge by gravity. If a system malfunction occurs, the resident(s) should be able to continue to use water for at least twenty-four hours, at their average daily flow, before depleting the reserve space. The need for emergency maintenance is minimal.
- 3) Provide a **clear zone** with sufficient **hydraulic retention time** for capturing grease, grit and other substances that settle or float. The clear zone (V_{cz}) lies between the scum and sludge layers. Dunbar (1908), Laak (1980) and Winneberger (1977) suggest minimum retention times from 6 to 24 hours for adequate suspended solids removal. Residential hydraulic retention based on *average* daily flows are usually adequate. The critical hydraulic retention time is determined just as the sludge and scum layers approach their minimum respective clear space limits. When a tank’s hydraulic retention time is sufficient for settlement, the clear zone contains liquid waste fairly free of solids.
- 4) Provide sufficient storage capacity for sludge and scum so that septage pumping is infrequent. The **scum layer** (V_{sc}) is that portion of the septic tank’s contents which floats. One-quarter of this layer is expected to float above the liquid level; three-quarters is submerged. **Scum clear space (A)** is the distance between the bottom of the scum layer at the pump’s “off” level and the outlet (top of the discharge ports) of the septic tank. This distance should be a minimum of three inches. The **sludge layer** (V_{sl}) is the accumulation of solids that settle on the bottom of the tank. **Sludge clear space (B)** is the distance between the top surface of the sludge and the outlet (bottom of the discharge ports) of the septic tank. For tanks having surface area of 2.5 m² (27 square feet) or more, this distance “B” should be a minimum of six inches. The following equation may be used to estimate the required sludge clear space for tanks with less than 2.5 m² (27 square feet) of surface area (Wiebel et al., 1955).

$$SCS (B) = 2.66 - 0.08A_{sl} \quad (1)$$

where: SCS is the sludge clear space (B), in feet.

A_{sl} is the sludge surface area, in square feet.

Solids Accumulation Rates

Predicting scum and sludge accumulations in order to determine septage pumping intervals is possible using data collected in various studies of septic tanks. The study most commonly cited is by Weibel, Bendixen and Coulter for the U.S. Public Health Service (1955), and its rate of accumulation has been corroborated by Winneberger (1977), and Bounds (1988). Sludge and scum accumulation rates, established with a high level of confidence (*usually 95 percent*), are used to estimate the frequency of septage removal, see figure 3. (*The statistical confidence level indicates that 95 out of 100 tanks do not*

require pumping before the intervals shown.) These curves represent the **gallons per person** that have accumulated at any given time in **years**, so they can be used to project pumping intervals for any occupancy and size or shape tank, including compartmented tanks.

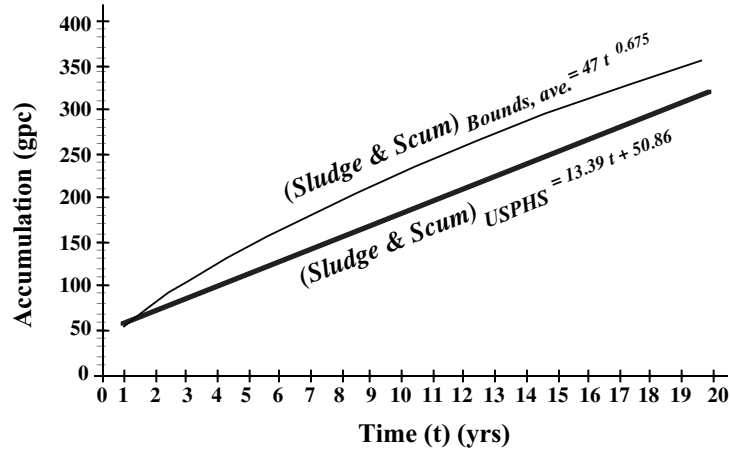

Figure 3: Rates of Septage (sludge/scum) accumulation (95 percent level of confidence)

Garbage Disposals

The 1980 EPA Onsite Wastewater Treatment and Disposal Systems Design Manual reports the use of kitchen garbage disposals increases both floatable and settleable solids accumulation in tanks; a U.S.PHS study (Weibel et al. 1955) quantified the increase in sludge and scum accumulation rates at about 37 percent. A study of the systems in Glide, Oregon (Bounds 1988) gave similar results: use of garbage disposals accelerated the scum accumulation by approximately 34 percent, yet made little difference, an increase of only 2 percent, in the rate of sludge accumulation.

Septic Tank Capacities

Effects of Occupancy, Loading and Tank Size

The total volume of the tank in Figure 2 is expressed as the sum of the volumes of the individual zones:

$$V_t = V_r + V_{oa} + V_{cz} + V_{sc} + V_{sl} \tag{2}$$

where: V_t = Total Volume, in L or gal

V_r = Reserve Volume, in L or gal

V_{oa} = Volume between off and alarm levels, in L or gal

V_{cz} = Volume of clear zone between scum and sludge layers, in L or gal

V_{sc} = Scum Volume = Rate of Accumulation (R_{sc}) x capita, in L or gal

V_{sl} = Sludge Volume = Rate of Accumulation (R_{sl}) x capita, in L or gal

The length of time between tank cleanings—the septage pumping interval—may be estimated by substituting all the known values into Equation (2) for total volume (V_t):

A typical interval range is illustrated in Figure 4. Given an average wastewater flow of 189 Lpcd (50 gpcd), scum clear space = 7.6 cm (3 in.), sludge clear space = 15.2 cm (6 in.), operating space (liquid level off to alarm) = 14 cm (5.5 in.), and a reserve storage time = 24 hours, a single family residential tank, for four (4) or fewer occupants, should be 3785 L (1000 gal) to 5678 L (1500 gal) for 5 to 7 occupants. The curves in Figure 4 result from the following nonlinear relationship developed for total sludge and scum accumulation shown in Figure 3, $(Sludge \ \& \ Scum)_{Bounds, 95\%}$:

$$N_{sl+sc} = 47 t^{0.675} \tag{3}$$

where: N_{sl+sc} is the volume of sludge and scum, in gallons/capita
 t is the time in years

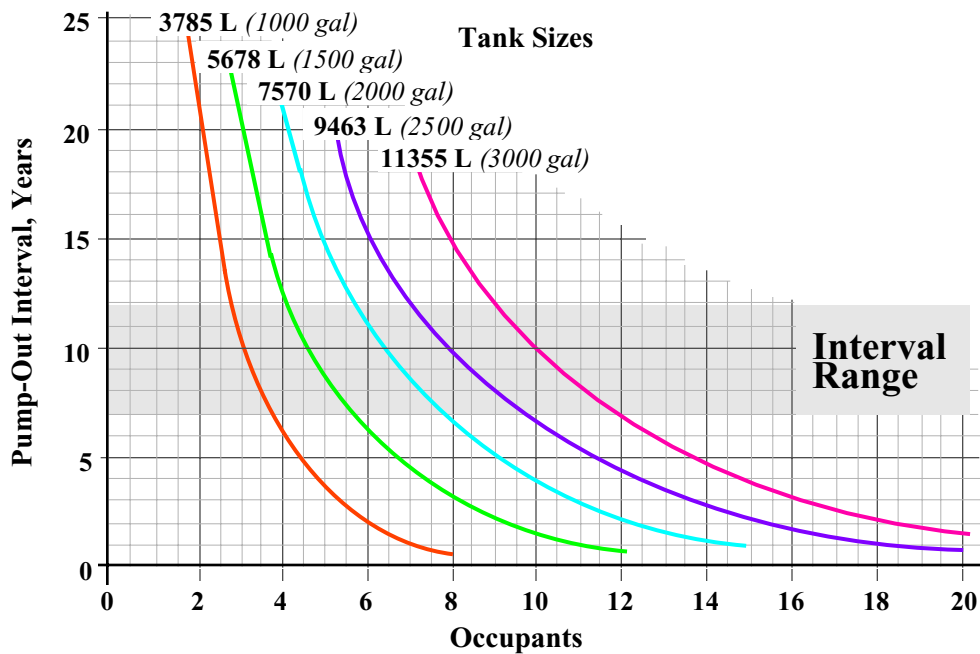

Figure 4: Pump-Out Intervals at 95% level of Confidence

The pump-out interval must be within a range that is affordable and provides adequate long-term solids retention for ensuring thorough digestion. Intervals that are too short not only retard digestion, but force users to pay significantly more for service and pumping. Philip et al. (1993) determined it takes about three (3) years to establish sufficient volatile organic acid concentrations for the methane formers. The initial additional cost for a larger prefabricated tank is usually insignificant, especially when compared to the present worth value of long-term maintenance.

Optimum Effluent Withdrawal Level

The product of the total septage accumulation, as expressed in Equation (3), and the occupancy load may be substituted into Equation (2), for the volumes of sludge (V_{sl}) and scum (V_{sc}), to determine the value of “t” in years. Hence, the depth of sludge and the value of “x” in Figure 2 (the depth from the floor up to the center of the discharge ports or bottom of tee) may be determined. The depth of the discharge ports, for most tank configurations, is usually found to center at about 70 percent of the

lowest operating liquid level. This is consistent with the requirement adopted by many governing jurisdictions that the withdrawal elevation “x” be at 65 to 75 percent of the lowest operating liquid depth. This method may be used to establish, for any given tank, the appropriate elevation from which the clear effluent should be withdrawn.

Tank Construction

Configurations

Septic tanks are constructed with an inlet and an outlet, with accesses for periodic removal of digested solids, and with one or more compartments. They are available in many sizes and configurations. See Figures 5, 6, 7, and 8. For residential applications, tanks are usually 3785 L (1000 gal) or 5678 L (1500 gal) but may be larger for homes with higher occupancy.

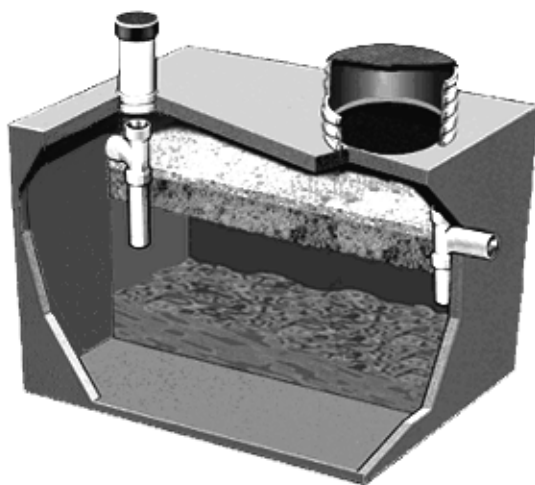

Figure 5: Typical Gravity Septic Tank
(Single Compartment)

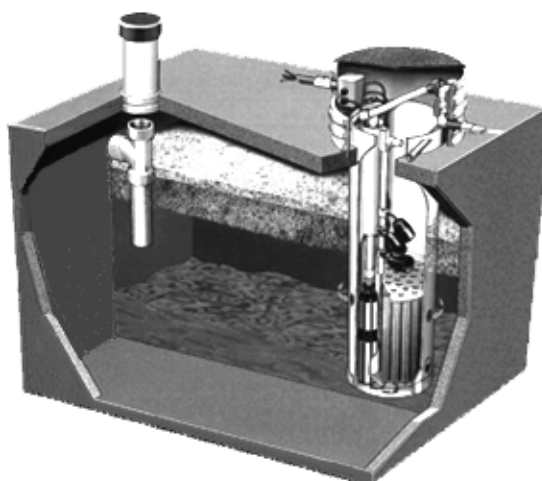

Figure 6: Typical Dosing Septic Tank
(Single Compartment)

Inlets

The inlet tee performs several essential functions. It directs the inflow into the mid-depth of the liquid level, which enhances the retention and accumulation of floating materials by ensuring the scum layer is not mixed or disturbed by the intruding flow. The change in direction of the flow dissipates its incoming velocity reducing the mixing action as the influent rushes in the tank; the settleable solids retention is improved by starting the settling at the clear zone level, nearer the bottom and sludge layer, rather than at the surface. It also provides a path for digested gases to be drafted through the building sewer and house vent. Without a proper inlet fixture, the effluent quality degrades with more solids, fats, oils, greases, soaps etc., washing through.

Shape

Properly configuring the dimensions and general shape of the tank is important to its performance. For instance square tanks, or tanks with short distances between inlets and outlets, tend to short circuit. Short circuiting results in a degradation of effluent quality. *The travel path from the inlet to the outlet fitting should be longer than the width or depth.* Tanks that are too long and narrow, however, may be awkward to transport or difficult to pump clean. Typical precast length to liquid depth ratios ($L:D$)

range from 1:1 to 3:1 ($1\frac{1}{2}:1$ to $2\frac{1}{2}:1$ are the most common). A typical height to width ratio ($H:W$) is 1:1. The reserve-storage/vent volume between the liquid surface and the soffit of the tank may range from 10 to 20 percent of the tanks total volume (*determined minimum volume based on average daily water usage, type of service and service response time*). Liquid depths may range from 76.2 cm (30 in.) to 213 cm (84 in.); minimum and maximum depth criteria vary with local regulations. Tank dimensions have not been established based on empirical performance data, but rather on established practices and available products. General observations, though, suggest that tanks with a long travel distance between the inlet and outlet perform better.

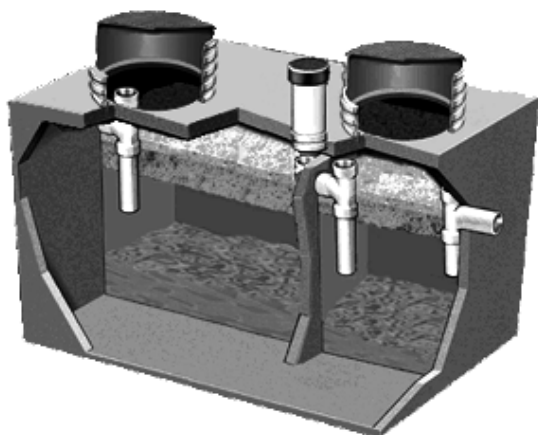

**Figure 7: Typical Gravity Septic Tank
(Two Compartment)**

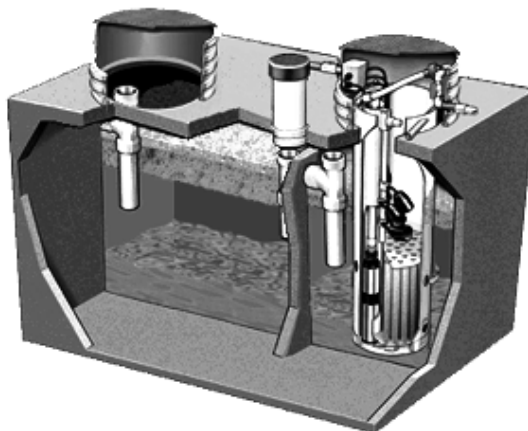

**Figure 8: Typical Dosing Septic Tank
(Two Compartment)**

Compartmentation

Over the years there has been continuing controversy over single-compartment versus two-compartment tanks. Evidence of significant benefits to effluent quality that would support compartmentation of tanks, as they are presently constructed, is inconclusive. The Public Health Service concluded its study by stating, “It cannot be stated conclusively that there was any significant difference in the operation of the one- and the two-compartment tanks.”

Winneberger (1984) explains the effect that velocities and turbulence have on the migration path of particles traveling through septic tanks and concludes, like Seabloom (1982), that slow velocities through long tanks yield the highest effluent quality. Winneberger makes two generalizations. First, “the geometric shape of a tank, as such, seems not to be critical. It is the management of flow-through that is of concern” and, second, “the size of that second chamber matters little.” However, the duration of these studies is insufficient for long-term predictions. Also, the studies have not adequately addressed how effluent quality is affected as sludge and scum accumulate in the primary compartment. An observation common to all the reports is that, as the hydraulic retention time increases, performance improves (i.e., larger compartments or tanks yield better quality effluents).

Regardless of the number, size or shape of supplemental compartments the primary or first compartment’s capacity should be designed based on hydraulic loading, velocity through the tank, reserve capacity, solids storage capacity and hydraulic retention time. Too little primary capacity can lead to excessive pump-out frequencies—a costly disaster for the community or individual that has to

deal with the mess and pay for the corrective measures. The difference in cost between a 5768 L (1500 gal) single compartment tank and a smaller 3785 L (1000 gal) two compartment tank is negligible. A larger such tank reduces pumping occurrences by a factor of four or more when servicing a family of three. Ultimately there will be less organic matter to dispose due to more complete digestion. Excessive hydraulic loads on holiday weekends or wash days will have less effect on the surge capacity of the larger tank. The money saved on unnecessary or less frequent pumping could wisely be spent on servicing and monitoring.

Municipal size cast-in-place tanks are frequently divided longitudinally into multiple parallel chambers to improve solids retention by increasing the flow travel distance. Winneberger (1984) refers to these configurations as meander tanks. He suggests, that the width of successive chambers could be narrower depending on the velocity and expected solids accumulation. Figure 9 illustrates a precast partition tank constructed by Willamette Graystone of Eugene, Oregon (Bounds 1996). Partitioning has the added advantage of substantially improving the tank's structural strength.

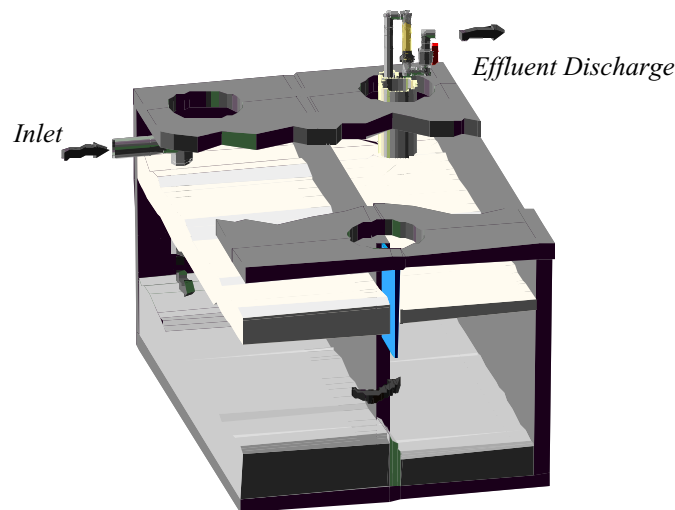

Figure 9: Partition Tank Configuration with Removable Scum Baffle

Methods of Discharge

Properly sized and designed tanks result in relatively clear effluent that may be discharged either by gravity or with siphons or pumps.

Gravity outlet assemblies have, in the past, been the cause of many septic system failures. Whether poorly constructed or poorly installed, many of the early style concrete fixtures or attached baffles would deteriorate and/or fall off allowing the scum layer to pass out of the tank. Greases, oils, fats and bulking solids would clog the system, necessitating costly repairs to the drainfield. Discharge technologies and tank standards have made tremendous advancements, so this is much less of a concern in current tank designs.

When discharged from screened assemblies, effluent may be conveyed through small diameter service lines (1 inch or 1¹/₄ inches in diameter) to its final destination.

Watertightness

Our greatest effort as an industry must be to get *properly sized, structurally adequate and watertight* tanks to all installations to ensure to quality and consistency of the discharge. The preponderance of septic tanks sold in the U.S. are structurally unsound and almost never watertight. Leaky tanks are unacceptable and watertightness is a requirement that should be mandatory for all onsite applications. Although most regulatory authorities require watertightness, enforcement is almost nonexistent. Testing criteria need to be established for gauging and enforcing quality.

Explicit details and specifications are necessary to ensure quality tank construction. Even so, unless strict quality control is uniformly enforced, manufacturers of quality tanks will find it hard to compete with those who make inferior tanks and sell them cheaply. The extra cost of a high quality tank is insignificant when compared to the cost of maintaining or replacing a system with inadequate tanks.

Where ground water levels are high, leaky tanks allow infiltration that causes solids and greases to wash through the tank, lowering treatment efficiency and leading to the eventual failure of onsite disposal systems. Infiltration/inflow (I/I) in effluent sewers overload both collection and treatment capacities. Hydraulic overloading, due to building sewer or tank leakage, causes degradation in the tank's effluent quality. Settleable and floatable solids, grease and oils are flushed from their storage zones. Hydraulically overloaded main lines restrict the user population of the system. Energy cost to convey this unnecessary contribution of water increases. Watertight systems allow more cost effective treatment and collection system designs. Ultimate population design potentials are not jeopardized by excessive hydraulic and organic stresses on treatment.

In 1985, the city of Montesano, Washington, was directed by the Washington Department of Ecology to correct the I/I problems in its municipal system. They had been considering a forty-acre lagoon system to handle I/I flows reported to be as much as 30 times normal dry weather flows. Instead, Montesano became the first community in history to convert from a gravity sewer to an effluent sewer. Currently there are 1230 connections serving an equivalent flow of about 1600 dwelling units. Residential tanks are fiberglass of 3785 L (1000 gal) capacity. Eighteen months following construction, engineers completed a year long study concluding that over 99 percent of the I/I had been removed. Final treatment is accomplished in a three-cell lagoon located on three acres.

Where high groundwater is not a problem, a leaky tank will exfiltrate, lowering the scum layer to the outlet level where the floatable solids, fats, soaps, oils and greases can be dosed or washed through the outlet assembly. Effluent that leaks directly into groundwater from a leaky tank contributes to groundwater contamination. Exfiltration hinders segregation and biological activity and proper development of a clear zone. Effluent quality degrades, organic digestion diminishes and service frequencies increase. Eventually, system failure ensues and/or maintenance becomes excessive and costly. It follows, then, that for wastewater systems with septic tanks to be efficient and reliable, and for predictions of solids accumulations and pumping intervals to have validity and continuity, septic tanks must be watertight.

The success of onsite and effluent sewer technologies is directly dependent on the quality of the design and construction of the tank.

Materials and Quality of Construction

The material most commonly used in the fabrication of septic tanks is reinforced concrete; fiberglass, polyethylene, and steel tanks are also options. Old-fashioned septic tanks, constructed without benefit of adequate design standards, quality control and with little or no reinforcing, are now outmoded.

Designers demand and progressive manufacturers are now able to supply sophisticated constructions that are engineered to be structurally sound and watertight. Leaky tanks, which commonly turn many traditional onsite systems into nothing better than cesspools, are no longer acceptable.

Reinforced concrete is usually the material of choice based on its cost-effectiveness, structural integrity, corrosion resistance, watertightness, buoyancy resistance, site suitability and installation ease.

Fiberglass has many of the same qualities and may be preferred because of its light weight where site accessibility for heavy equipment is limited or restricted. Where permanent or temporary high ground waters exist, however, fiberglass tanks must be installed so that they resist buoyancy. Steel tanks with thick corrosion resistive coatings and cathodic protection are used with success in some areas. The slightest damage to the protective coating, however, may expose the steel and severely shorten the tank's life, which is normally about 20 years. Polyethylene's strength is intrinsically less, so poly tank installations are typically restricted to unsaturated sites with reduced structural requirements. Poly tanks require additional bedding and backfilling efforts, and in some locations may require a low-strength concrete backfill.

Design Guidelines

Following are guidelines* for quality tanks for standard locations. In areas where burial depth must be more than four feet or where heavy traffic or other loading is expected, additional support may be necessary.

General Design Criteria

- a. Top = 500 psf *(The tank shall be capable of supporting long-term unsaturated soil loading in addition to the lateral hydrostatic load.)*
- b. Lateral Load = 62.4 pcf *(The tank shall be capable of withstanding long-term hydrostatic loading with the water table maintained at ground surface.)*
- c. Concentrated Wheel Load = 2500 lb. *(The tank and accesses shall be capable of supporting short-term wheel load in addition to the unsaturated soil loading.)*
- d. Soil Bearing = 1000 psf *(Soil bearing is site specific and must reflect the worst case conditions.)*
- e. Cold weather installations requiring deep burial need special consideration.
- f. All tanks shall successfully withstand an above ground static hydraulic test.
- g. The inlet plumbing shall penetrate at least 30.5 cm (12 in.) into the liquid from the inlet flow line. If the submerged scum depth is expected to be greater than 30.5 cm (12 in.), the inlet fixture should be extended into the liquid two inches below the expected lowest scum depth.

General Specifications

- a. Manufacturer's Guarantee shall be for a period of two years.
- b. All tanks shall be installed in strict accordance with the manufacturer's instructions.

*Updated per IAPMO standards, August 2001.

Concrete tanks

The walls, bottom and top of reinforced-concrete tanks are usually designed spanning the shortest dimension using one-way slab analysis. Stresses in each face of monolithically-constructed tanks are determined by analyzing the tank's cross-section as a continuous fixed frame.

The walls and bottom slab should be required to be poured monolithically. When a tank is expected to be submerged, subjected to heavy traffic loads, or buried deeply, the top slab must be cast onto the walls with wall reinforcement extending into the top slab.

The bottom thickness of the wall should be equal to the thickness of the floor, which is usually thicker. At the wall-floor joint the stress is equally shared; therefore, steel spacing is more efficient and cost effective if the wall thickness is equal to the thickness of the floor. The wall can taper to *three* inches at the top. Tapering the interior mold at the bottom improves the flowability of the concrete around the walls and into the floor. Chamfering the wall-floor junction on the inside reduces the effect of suction between the tank-mold and concrete surfaces; thus the integrity of the concrete at the joint is better maintained and less effort is needed to remove the interior mold.

Casting the top in place will produce a much stronger tank than will setting the top in place. A cast on lid, with wall reinforcement adequately tied to the top reinforcement, improves the structural capacity of the top and bottom by more than 40 percent and the walls by about 25 percent. The required rebar spacing will be wider, which reduces materials cost and labor in fabrication. With the wall and top joint cast together there is greater assurance that if differential settlement occurs the top will not separate from the wall causing loss of lateral support at the top. Separation of the top lid from the wall would significantly reduce the tank's strength and its watertightness would be lost. Set in place lids must be mechanically attached to the walls to assure the joint does not separate when the tank shifts or settles.

Concrete Specifications

Concrete must achieve a minimum compressive strength of 4,000 psi in 28 days. The design of the concrete mix depends on the gradation of the aggregate and should be determined by a professional engineer. A common 4000 psi ready-mix design has a cement content of six and one half ($6\frac{1}{2}$) sacks per cubic yard and maximum aggregate size of 19 mm ($\frac{3}{4}$ in.) (*Ready-mix cement conforming to ASTM C-150, Type II.*)

Water/Cement Ratio. To ensure proper curing and ultimate strength, it's important to keep the water/cement ratio low, 0.35 ±.

Air-entraining agents may be required depending on the mix design, although they are not usually necessary for small concrete tanks. Air-entrainment without additives is usually 1 to 2 %.

Fiber Additives may be used to enhance watertightness by controlling concrete shrinkage.

Protective Coatings. Heavy *cement-based* sealants may be used inside and out. The manufacturer's directions must be followed exactly. *Bituminous coatings are not necessary.* In Pomeroy's work for the EPA, published as *1974 Sulfide Control In Sanitary Sewerage Systems*, he recognized that bituminous coatings were not effective in reducing sulfide corrosion. Winneberger discusses the fact that the

atmosphere in a well vented septic tank is not greatly different from the atmosphere above grade. Hydrogen sulfide concentrations were lower than what could be measured by wet chemistry techniques. Methane was also non-detectable. Only the oxygen concentration was a bit below that of the outside atmosphere.

Reinforcing Steel shall be Grade 60, $f_y = 60,000$ psi (*ASTM A-615 Grade 60*). Size and placement must be determined by a structural engineer. Wire fabric is not acceptable. Weldable steel may be specified if the reinforcing cage is to be tack welded during assembly. Misalignment of reinforcement in a three inch thick section can significantly reduce the strength of the tank; for instance, a quarter inch of misalignment will reduce the capacity of that section by about thirty percent, one-half inch of misalignment will reduce the capacity by fifty percent.

Form Release must be Nox-Crete or equal. Diesel or other petroleum products are not acceptable.

Vibration. Tank molds must have attached vibrators to ensure adequate flow of concrete down the walls and across the bottom. Excess vibration can cause the aggregate to segregate.

Curing. Proper curing techniques are necessary to ensure watertight tanks. Tanks must not be moved until they have cured for seven (7) days or have reached two-thirds of the design strength.

Test Cylinders must be taken from each batch of concrete and tested until the minimum compression strength has been obtained.

Fiberglass Tanks

Glass fiber and resin content must comply with IAPMO IGC 3-74, and there should be no exposed glass fibers.

Metal parts must be 300 series stainless steel.

Wall thickness must average at least 6.3 mm ($1/4$ in.) with no wall thickness less than 4.8 mm ($3/16$ in.). No delamination is allowable.

Holes specified in the tank must be protected with an application of resin on all cut or ground edges sufficient so that no glass fibers are exposed and all voids are filled.

Neoprene gaskets, or an approved equal, must be used at the inlet to join the tank wall and the ABS inlet piping. ABS Schedule 40 pipe and fittings must be used at the inlets.

Testing

Follow these test procedures to ensure watertightness. Test every tank at the factory and again after installation:

- 1) Fill the tank to its brim with water and let it stand for 24 hours. To help expedite larger orders a vacuum test may be substituted at the factory, and after the tanks are delivered to the job site. A vacuum test may not, however, take the place of the final installed static water test.

- 2) Measure the water loss; if there is no water loss during the first 24 hours the tank is acceptable for installation. Some water absorption, however, may occur during this first time period. If so, refill the tank and determine any exfiltration by measuring the water loss over the next two (2) hours. Any water loss is cause for rejection.
- 3) Install the tank and repeat steps 1 and 2. These procedures should be followed after setting and after backfilling. Test the seal between the riser and the tank top for watertightness by filling the riser with water to a level 2" above the top brim of the tank. *Caution: To prevent hydrostatic uplift damage to the top joint of the tank, do not allow the level of water in the riser to exceed the level of the backfill.*

Buoyancy

Improper septage pumping of a buried tank may result in the tank suddenly “floating” to the surface, causing damage to piping, landscaping or worse, injuring maintenance personnel. The following precautions help to ensure tank submergence in areas with high groundwater:

- Require a minimum cover where high groundwater conditions are suspected (evaluation must be provided after identifying site specific soil conditions).
- After setting the tank, pour an additional 15.25 cm (6 in.) of concrete over the top; extend a minimum of 30.5 cm (12 in.) beyond the sides of the tank. Lightweight plastic tanks (\approx 400 lbs) require concrete or other counter measures sufficient to exceed the buoyant force.
- The weight of concrete tanks can be increased by adding thickness to the walls, top and/or bottom.
- Operation and maintenance instructions should clearly state that tanks must never have more than half (50%) of their contents pumped out during periods when the groundwater is high; especially if they are located in sandy soil. This recommendation is for cautionary purposes only, and is not a substitute for physical buoyancy restraints.

Monitoring

Even under ideal conditions, estimates of septage pumping intervals are useful in predicting the amount of maintenance required by a population of tanks, not in determining when an individual tank needs to be pumped. The only way to know when a tank needs to be pumped is through direct measurement of the scum and sludge thickness. The monitoring experience from Glide showed that after five years, considerably less than half of most tanks’ scum and sludge capacity had been reached (Bounds, 1988). Onsite design manuals may encourage frequent pump-outs as a precautionary measure when an inspection program is not in effect, however, longer intervals are usually justified, particularly if an effluent screening device is in place.

Conclusion

In summary, structurally adequate and watertight septic tank systems are no longer considered a temporary stopgap until such time as a “real” sewer can be built. As technology has improved the image of the septic tank, it has come to be appreciated as a component of an *efficient* and *permanent* solution. As such, it deserves to be accorded the same scientific consideration as other treatment systems. Structural designs and quality assurance should be based on the same long-term and physical loading criteria required of all submerged wastewater treatment vessels. Adequate sizing procedures and designs for watertight tanks are available. Sizing must be based not only on occupancy, but on biological, hydraulic and chemical loading conditions. Predicting reasonable septic tank pumping intervals with a

respectable degree of reliability is an achievable goal. Suggestions or requirements that all septic tanks must be pumped every two, three or even five years are simply unsupported by scientific evidence. The microbial activity that affects optimal decomposition takes up to three years to develop fully (Philip et al. 1993). When a management program is in place, pump-outs are scheduled based on inspections and monitoring records so that costs are controlled.

Current septic tank technologies are capable of treating wastewater (*onsite*) to a higher level of quality than do the vast majority of municipal treatment plants. Properly designed, these onsite technologies are more fail safe and fail soft than municipal facilities.

Effluent sewer and onsite wastewater technologies have been established as an affordable and reliable alternative. Passive—energy free—septic tanks provide the most cost efficient method of primary treatment available for nonindustrial sewage.

References

- Ball, H.L., 1994, “Nitrogen Reduction in a Onsite Trickling Filter/Upflow Filter Wastewater Treatment System,” Onsite Wastewater Treatment, American Society of Agricultural Engineers, Atlanta, Georgia.
- Barshied, Robert D. and Hassan M. El-Baroudi, October 1974, “Physical-Chemical Treatment of Septic Tank Effluent,” Journal of the Water Pollution Control Federation.
- Bennett, E.r. et al., 1975, “Rural Home Wastewater Characteristics,” Proceedings of National Home Sewage Disposal Symposium, American Society of Agricultural Engineers.
- Bitton, Gabriel, 1994, “Wastewater Microbiology,” John Wiley & Son’s, Inc. Publication.
- Bounds, T.R., 1982, “Wastewater Characteristics Glide, Oregon, Pressure Sewer System,” Douglas County Department of Public Works, Roseburg, Oregon.
- Bounds, T.R., 1988, “Glide Audit 1986-1987, Summary of Sludge and Scum Accumulation Rates,” Douglas County Department of Public Works, Roseburg, Oregon.
- Bounds, T.R., 1995, “Septic Tank Septage Pumping Intervals,” 8th Northwest Onsite Wastewater Treatment Short Course and Equipment Exhibition. University of Washington Department of Civil Engineering/Washington State Department of Health.
- Bounds, T.R., February 1996, “Alternative Sewer Designs Effluent Sewer Technology Septic Tank Effluent Pump and Septic Tank Effluent Gravity Systems” Orenco Systems Inc., Sutherlin, Oregon.
- Bounds, T.R., 1996, “Design of Partition tank using tank dimensions for Willamette Graystone of Eugene, Oregon,” Orenco Systems Inc., Sutherlin, Oregon.
- Cagle, Wm. A. and Johnson, Lynn A., 1994, “Onsite Intermittent Sand Filter Systems, A Regulatory/Scientific Approach to their study in Placer County, California,” Onsite Wastewater Treatment, American Society of Agricultural Engineers, Atlanta, Georgia.

- Carcich, Italo G. et al, 1972, "A Pressure Sewer System Demonstration," Environmental Protection Agency.
- Commission on Rural Water, 1973, "Wastewater Treatment Systems for Rural Communities."
- Dunbar, Prof. Dr., 1908, "Principles of Sewage Treatment," Charles Griffin & Co., Ltd., London, England.
- Kreissl, J.F., 1971 "Waste Treatment for Small Flows," Paper presented to the 1971 annual meeting, American Society of Agricultural Engineers. Washington State University, Pullman, Washington, June 27-30, 1971.
- Laak, Rein., 1980, "Wastewater Engineering Design for Unsewered Areas," Ann Arbor Science Publishing /The Butterworth Group, Ann Arbor, Michigan.
- Lawrence, C.H., Nov/Dec 1973, "Septic Tank Performance," Journal of the Environmental Health, Volume 36, No. 3 page 220.
- McKinney, Ross E., 1962, "Microbiology for Sanitary Engineers," McGraw-Hill Book Company ISBN 07-045180-X.
- Metcalf and Eddy, Inc., Collection, Treatment, Disposal 1972, "Wastewater Engineering," (New York: McGraw-Hill).
- Metcalf and Eddy, Inc., 3rd Edition, 1990, "Wastewater Engineering," (New York: McGraw-Hill).
- Otis, R.N., N.J. Hutelek and W.C. Boyle, September 1973, "On-Site Household Wastewater Treatment Alternatives, Laboratory and Field Studies," paper, presented at the Rural Environmental Engineering Conference, Warren, Vermont.
- Philip, H., Maunoir, S., Rambaud, A., and Philippi, L.S., 1993. "Septic tank sludge's: accumulation rate and biochemical characteristics," proceedings of the second international specialized conference on design and operation of small wastewater treatment plants. Trondheim, Norway.
- Pomeroy R.D., Johnson and Bailey, 1974, Process Design Manual for "Sulfide Control in Sanitary Sewerage Systems," U.S. EPA Technology Transfer.
- Ronayne M.P., R.C. Paeth and S.A. Wilson, 1982, "Final Report: Oregon Onsite Experimental Systems Program," Oregon Department Of Environmental Quality.
- Seabloom Robert W., Dr., 1982, "Septic Tank Performance Compartmentation, Efficiency and Stressing," Professor, Department of Civil Engineering, University of Washington, Seattle Washington.
- Stuth, Wm. Sr., 1993 "Effect of screened vault technology in a two compartment tank," lab results.

- Taber, W.A. 1996, Wastewater Microbiology Ann, Rev. Microbial. 30:263-277.
- Tyler, E.J., R.B. Corey and M.U. Olotu., 1978 “Potential Effects of Water Softener use on Septic Tank Soil Absorption Onsite Wastewater Systems,” Final Report to the Water Quality Research Council. University of Wisconsin, January 1975, “Papers by Small Scale Waste Management Project.”
- U.S. Environmental Protection Agency, 1991. Manual: alternative wastewater collection systems, EPA/625/1-91-024.
- U.S. Environmental Protection Agency, 1980. Design Manual-Onsite Wastewater Treatment and Disposal Systems.
- U.S. Department of Health, Education, and Welfare, formerly U.S. Public Health Service, 1957 (reprinted 1972). Manual of Septic-Tank Practice, Publication No. 526.
- Water Pollution Control Federation, 1986, “Alternative Sewer Systems,” Manual of Practice, MOP No. FD-12.
- Watson, K.S., R.P. Farrell and J.S. Anderson. January 1967. “The Contribution from Individual Homes to the Sewer System.” Journal of the Water Pollution Control Federation.
- Weibel, S.R., Bendixen, T.W., and Coulter, J.B., 1955, “Studies on Household Sewage Disposal Systems, Part III,” U.S. Public Health Service Publication No. 397.
- Weibel, S.R., et al. 1949, “Studies of Household Sewage Disposal Systems,” U.S. Public Health Service.
- Winneberger, John Timothy, Ph.D., 1977, Consultant, Septic tank systems, personal communication titled Interceptor tank design.
- Winneberger, John H. Timothy, 1984, “Septic-Tank Systems, A Consultant’s Toolkit, Volume II the Septic Tank”, Butterworth Publishers/Ann Arbor Science.
- Zeibell, W.A., D.H. Nero, J.F. Deininger and E McCoy, 1974, “Use of Bacteria in Assisting Wastewater Treatment and Soil Disposal Systems,” Proceedings of the National Symposium on Home Sewage Disposal, ASAE.