

Australian
Standard
AS/NZS
1546.1
Lic 1950
Septic Tanks



POLYMER SEPTIC TANKS

2500L – 3000L – 3900L - 4000L

Tested to comply with AS/NZS 1546.1:1998

Assembly and Installation Instructions

Parts supplied with Tank Kits:

- | | | | |
|----|------------------------------------|-----|---------------------------------------|
| 1: | One moulded Plastic Inlet Fitting | 8: | Two moulded Plastic Inspection Covers |
| 2: | Two Rubber Seal Gaskets | 9: | One moulded Plastic Access Cover |
| 3: | One moulded Plastic Tank Body | 10: | Synthetic Rope |
| 4: | Thirty-six Stainless Steel Screws | 11: | Two Stainless Steel Bolts |
| 5: | One moulded Plastic Outlet Fitting | 12: | Two Stainless Steel Nuts |
| 6: | One Plastic Partition Assembly | 13: | Two Stainless Steel Washers |
| 7: | One moulded Plastic Tank Top Cover | | |

Small parts are packed in a plastic bag for security.

Note: Items 6, 11, 12, & 13 are only for use in areas where local regulatory authorities require Partitions to be fitted. In other areas, the Partition will only be supplied on special request.

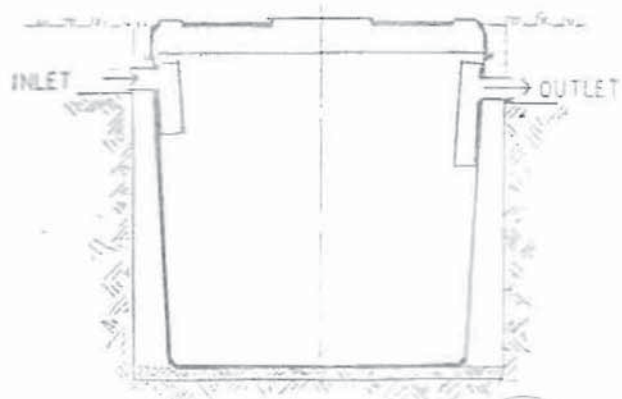

Figure 1

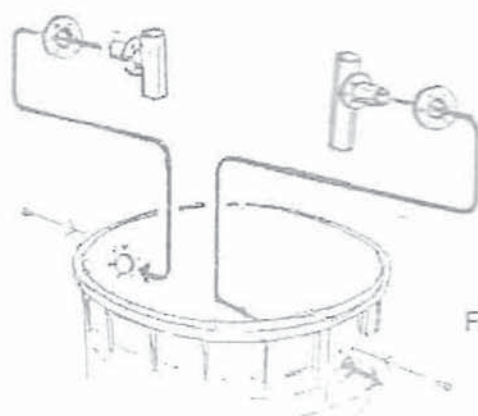

Figure 2

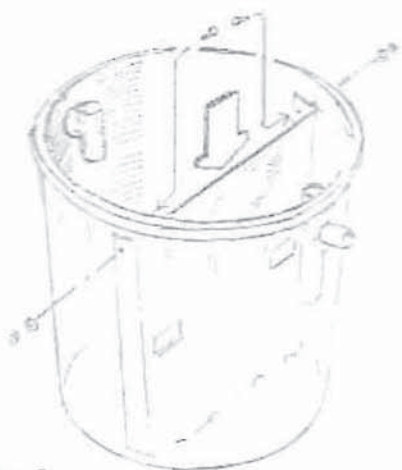

Figure 3

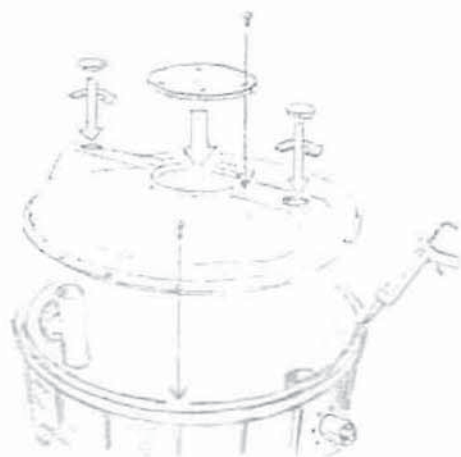

Figure 4



Figure 5



Figure 6

FIGURE 1 Excavate Hole

- a) Tank location should be carefully selected to ensure that no surface water or stormwater collects there, or will be directed to it. Depth of hole depends on fall of pipe due to distance of tank and disposal system from residence. Hole must not be so deep that the Tank Top Cover will be completely covered. Tank Inspection and Access Covers **MUST** be above final ground level.
- b) Bottom of hole for Tank is measured from the bottom of the trench for the pipe feeding the Tank inlet.

Tank type	Surface to Bottom of Inlet Pipe Trench	Inlet Pipe Trench to Bottom of Hole for Tank	Total Depth Maximum
2500L Standard	385 maximum	1285mm	1670mm
3000L Standard	385 maximum	1535mm	1920mm
3900L Standard	385 maximum	1885mm	2270mm
4000 LStandard	385 maximum	1985mm	2380mm
2500L Deep Site	600 maximum	1320mm	1920mm
4000L Deep Site	550 maximum	1970mm	2520mm

- c) Trench for Discharge pipe **MUST** be 50mm below trench for Inlet Pipe.
- d) Hole should have **NO** matter projecting inwards. No roots or foreign matter should be present. Finished excavation should not be less than 2100 diameter for four anchors. (Four Anchors from 100mm uPVC Sewer grade pipe not less than 900mm long are recommended. Enough lengths of synthetic rope specified for this purpose are provided with EVERHARD Tanks. In some cases stainless steel cables may be used instead of synthetic ropes. These must be fitted to the Tank with Shackles.
- e) Place a layer of clean bedding sand in the hole and compact to minimum 50mm thick. Sand surface must be flat and level, and free from all foreign matter.

FIGURE 2 Pipe Connection Fittings

- a) Assemble Inlet Fitting 1 (short tail Tee) and Seal Gasket 2 into inlet hole in wall of Tank 3 (closest to Tank rim). Secure with six Stainless Steel Screws 4.
- b) Fit Outlet Fitting 5 (long tail Tee) and Seal Gasket 2 into outlet hole of Tank 3. Secure with six Stainless Steel Screws 4.
- c) Tighten Screws enough to pinch Gaskets. **DO NOT OVER-TIGHTEN SCREWS.**

FIGURE 3 Partition (if required by local regulatory authority)

- a) Partition sides are held by plastic ties to stop the flanges unfolding during transport. Remove ties before installing Partition.
- b) Position Partition 6 in Tank 3 with side flanges towards Tank Inlet. Bottom edge of Partition must be located between pairs of lugs in Tank Bottom nearest Tank outlet. Press down firmly to ensure a close fit all round. Align the Outlet side of the Partition with the engraved cross marks on the Tank Wall. Partition should lean slightly towards the Outlet.
- c) Drill 6mm hole through both Partition side flanges and the Tank Wall not more than 75mm down from top of Partition, to accept Stainless Steel Bolt 11. The Nut 12 and Washer 13 must be on the outside of the Tank.

FIGURE 4 Tank Top Cover

- a) Apply a full bead of suitable silicone sealant into Tank rim.
- b) Position Tank Top Cover 7 with Inspection Openings directly above Inlet and Outlet Fittings. Secure with sixteen Stainless Steel Screws 4 through pre-drilled holes in Top Cover flange. Drive Screws into Tank Rim. **DO NOT OVER-TIGHTEN.**
- c) Fit Inspection Covers 8 in holes in Top Cover. Turn clockwise to lock.
- d) Fit Access Cover 9 to Top Cover and secure with six Stainless Steel Screws 4 through pre-drilled holes in Access Cover rim. Drive Screws into Tank Top Cover. **DO NOT OVER-TIGHTEN.**

Note: A thin bead of suitable silicone sealant under Inspection and Access Cover edges will help prevent the entry of surface water.

FIGURE 5 Ground Anchors (in accordance with AS/NZS1546.1:1998)

- a) Put one end of each of eight pieces of synthetic rope 10 through pre-drilled holes in vertical tank ribs and tie off securely. Fill four Ground Anchor Pipes with sand and fit end caps. Place these around the Tank, and make the free end of each rope secure around one end of a Pipe, with two ropes to each. The Pipes should hang level, and be just off the ground, beside the Tank with all ropes fully secured and all tied knots completely tightened. Anchors **MUST** be evenly spaced around the Tank.

FIGURE 6 Installation

- a) Lower Tank carefully into the prepared hole. Align Inlet and Outlet Fittings with trenches and piping. Do not disturb bedding sand. Ensure Tank is firmly seated and checked level with a spirit level across and along flat sections of the Tank Top Cover. Pack Pipe Anchor Pipes with sand and cap ends. Anchors should hang horizontal beside the Tank with **NO SLACK** in the ropes. Sand filled pipes will keep ropes taut and will also help prevent movement under backfill.
- b) Adequate ground anchorage is needed to ensure that the Tank remains in the ground when it is emptied, and its' natural buoyancy tends to make it float in wet soil. Backfill should be soil stabilised with cement. Sand, aggregate, crushed rock or other porous material is not suitable as this will saturate with ground water and allow movement. **Where the backfill may not provide a homogenous mass able to overcome the uplift effect on Pipe Anchors (for example where the water table is very high and/or the soil is stony) extra anchorage is recommended.** Pre-Cast Reinforced Concrete Slabs may be placed over Anchor ends, or several bags of pre-mixed Concrete may be poured over the ends of Pipe Anchors. Quantities of concrete may also be poured at equal intervals around the base of the Tank so that the lower ribs of the Tank wall are covered. When set, these will help secure the Tank and prevent movement. **Take extra care when installing a Collection Well as this will often be empty in service, producing more uplift effect and requiring extra anchorage.** Adding weight on top of the Tank is not a recommended practice as this can cause deformation and failure.
- c) Connect inlet and outlet piping to the Tank Fittings. These accept standard 100mm uPVC SWV pipe with rubber ring joint sockets, or rubber sleeves with stainless steel clips. Possible minor misalignment of pipes due to ground movement must be allowed for. **DO NOT** use Pan Connectors or rely on Solvent Cement Socket Connections.
- d) Fill the Tank with clean fresh water to the Outlet pipe level. Check for leaks around Inlet and Outlet and pipe connections. Apply silicone sealant and tighten Screws if Fitting Gaskets leak. Remove and re-seat rubber rings if pipe connections leak.
- e) Backfill the excavation and **LIGHTLY** compact around the Tank with stabilised soil. Clay may be smeared around the surface to reduce risk of water permeating into the backfill. **DO NOT USE SAND OR GRAVEL BACKFILL, OR MATERIAL CONTAINING SHARP ITEMS, ROCK, RUBBLE, RUBBISH, OR FOREIGN MATTER.**

The Standard Tank Top Cover MUST NOT be completely buried under any circumstances.

Where the Tank Inlet and Outlet have to be deeper than permitted by the Standard Tank design, matching Risers by EVERHARD may be used on 2500L and 3000L Tanks. If a Riser is used, the accompanying internal Reinforcing Band MUST also be fitted.

IMPORTANT NOTES

EVERHARD Polymer Septic Tanks have been tested to support the 5kN (500kg) top load and likely side loading required by the National Standard AS/NZS1546.1:1998 for small septic tanks. This is not an indication that Tanks can be expected to safely withstand continually applied loads. No regular pedestrian traffic over Tanks should be permitted. No vehicle traffic should be permitted within 600mm of any tank unless an approved, load carrying, hard-stand traffic area is provided. Tanks MUST NOT be completely buried. There must be clear access to the Access and Inspection Covers at all times.

When positioning pipes and Septic Tanks, note that The National Plumbing and Drainage Code AS/NZS3500.2.2:1996 Section 3.7 specifies minimum cover over sanitary drainage piping as follows:

Location	Cast or Ductile Iron	For Other Materials and if Insufficient Cover.
Public Roads, rights of way, and areas open to heavy vehicles.	300mm minimum	500mm minimum – or - 50mm overlay and 150mm paving
Other driveways, light vehicle areas.	300mm minimum	450mm minimum – or - 50mm overlay and 75mm paving.
Elsewhere – No vehicles, pedestrian only.	Nil	300mm minimum – or - 50mm overlay and 50mm paving.

EVERHARD Polymer Septic Tanks offer adequate cover for pipes in most applications. (See the table attached to the installation instructions). Where it is necessary for inlet pipes to be deeper than permitted by the Standard Tank designs, Deep Site 2500L Tanks are available with 540mm inlet pipe cover. Risers for Standard 2500L and 3000L Tanks are available which allow the inlet pipe to have up to 625mm cover. *When installing Risers, it is essential that the Internal Reinforcing Band supplied with each unit MUST be fitted in strict accordance with the instructions supplied.*

Most installations require Septic tanks to be in-ground, as described in this instruction manual. However, the EVERHARD Polymer Septic Tank may be installed in a partially or fully above-ground situation. In such cases, care must be taken to ensure that the Tank, and any associated piping, is adequately supported, anchored, and protected against possible accidental damage. Note that the material used for the Tank body is not so heavily shielded against Ultra-violet radiation as the Top Cover. It is therefore important to protect the tank body against exposure to full sunlight. Protective screens or paints may be used.

Other products available for use with EVERHARD Polymer Septic Tanks include the popular Xtra-treat Filter which can be quickly and easily fitted into the Outlet Fitting inside the Tank at any time. These offer improved protection against solid particles, suspended in the treated fluid, being carried into the discharge piping. An Xtra-treat Filter can greatly extend the service life of the disposal system.

EVERHARD also produces a range of effluent Distribution Boxes in Concrete and in durable, tough Plastic. These complement the cost-effective and very efficient plastic EVERTRENCH Trench Liner for use in Evapo-Transpiration and Soakage Systems.

Contact any EVERHARD office or distributor for information on our extensive range of products for the plumbing and building industry.