

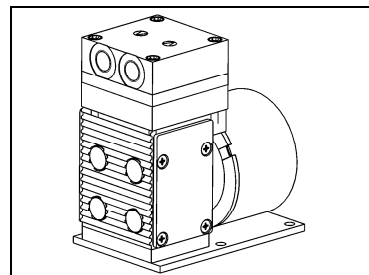

Double Diaphragm Pumps

N 86 AN.12.29 DC-B

N 86 AP.12.29 DC-B



Operating and Installation Instructions

Read and observe these
Operating and Installation
Instructions!

N 816 AV.12.29 DC-B

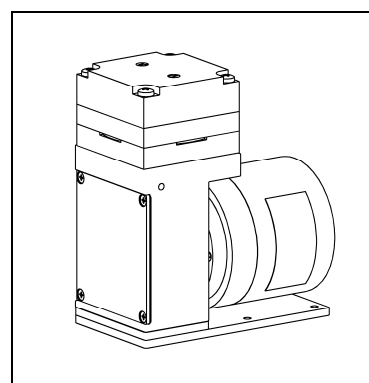

N 838 AN.12.29 DC-B

N 838 AP.12.29 DC-B

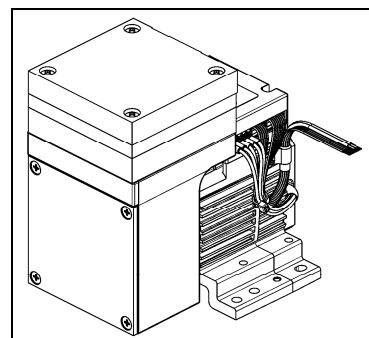

KNF Neuberger GmbH
Alter Weg 3
D-79112 Freiburg
Germany
Phone +49-(0)7664-5909-0
Fax +49-(0)7664-5909-99
E-mail: info@knf.de
www.knf.de

Contents	Page
1. About this document.....	2
2. Use	3
3. Safety	4
4. Technical Data	6
5. Design and function.....	10
6. Installation and connection.....	12
7. Operation.....	20
8. Servicing.....	27
9. Troubleshooting.....	35
10. Spare parts and accessories.....	38
11. Returns.....	40
12. Health and safety clearance and decontamination form.....	41

1. About this document

1.1. Using the Operating and Installation Instructions

The Operating and Installation Instructions are part of the pump.

➔ Pass on the Operating and Installation Instructions to the next owner.

Project pumps

Customer-specific project pumps (pump models which begin with "PJ" or "PM") may differ from the Operating and Installation Instructions.

➔ For project pumps, also observe the agreed upon specifications.

1.2. Symbols and markings

Warning



WARNING

A danger warning is located here.

Possible consequences of a failure to observe the warning are specified here. The signal word, e.g.

Warning, indicates the danger level.

➔ Measures for avoiding the danger and its consequences are specified here.

Danger levels

Signal word	Meaning	Consequences if not observed
DANGER	warns of immediate danger	Death or serious injuries and/or serious damage are the consequence.
WARNING	warns of possible danger	Death or serious injuries and/or serious damage are possible.
CAUTION	warns of a possibly dangerous situation	Minor injuries or damage are possible.

Tab. 1

Other information and symbols

➔ An activity to be carried out (a step) is specified here.

1. The first step of an activity to be carried out is specified here. Additional, consecutively numbered steps follow.

i This symbol refers to important information.

2. Use

2.1. Proper use

The pumps are exclusively intended for transferring gases and vapors.

Owner's responsibility

Operating parameters and conditions

Only install and operate the pumps under the operating parameters and conditions described in Chapter 4, Technical data.

Only complete pumps may be taken into service.

Make sure that the installation location is dry and the pump is protected against rain, splash, hose and drip water.

Requirements for transferred medium

Before using a medium, check whether the medium can be transferred danger-free in the specific application case.

Before using a medium, check the compatibility of the materials of the pump head, diaphragm and valves with the medium.

Depending on the medium being pumped, a rupture of the working diaphragm may produce a potentially dangerous mixture when the medium mixes with the air in the innerspace between the working diaphragm and the safety diaphragm.

- KNF recommends monitoring pressure and flow rate of the pneumatic system in which the pump is integrated.
- If pressure or flow rate change without apparent reason, immediately switch off the pump and check for damages.
- Immediately stop the pump if the working diaphragm ruptures. The working diaphragm and the safety diaphragm must be replaced before continuing with operation (see chapter 8, Maintenance).

Only transfer gases which remain stable under the pressures and temperatures occurring in the pump.

2.2. Improper use

The pumps may not be operated in an explosive atmosphere.

The pumps are not suitable for transferring dusts.

The pumps are not suitable for transferring liquids.

The pumps are not suitable for aggressive media. For aggressive media there are other pumps in the KNF product program – please ask us for detail.

Pumps designed to create either a vacuum or an overpressure must not be used for these two purposes simultaneously.

An overpressure must not be applied to the suction side of the pump.

3. Safety

i Note the safety precautions in sections 6. *Installation and connection*, and 7. *Operation*.

The pumps are built according to the generally recognized rules of technology and in accordance with the occupational safety and accident prevention regulations. Nevertheless, dangers can result during their use which lead to injuries to the user or others, or to damage to the pump or other property.

Only use the pumps in proper technical condition and in accordance with their intended use in a safety and danger-conscious manner while observing the Operating and Installation Instructions.

Personnel	<p>Make sure that only trained and instructed personnel or specially trained personnel work on the pumps. This especially applies to assembly, connection and servicing work.</p> <p>Make sure that the personnel has read and understood the Operating and Installation Instructions, and in particular the "Safety" chapter.</p>
Working in a safety-conscious manner	Observe the accident prevention and safety regulations when performing any work on the pump and during operation.
Handling dangerous media	When transferring dangerous media, observe the safety regulations when handling these media.
Handling combustible media	<p>Be aware that the pumps are not designed to be explosion-proof.</p> <p>Make sure the temperature of the medium is always sufficiently below the ignition temperature of the medium, to avoid ignition or explosion. This also applies for unusual operational situations.</p> <p>Note that the temperature of the medium increases when the pump compresses the medium.</p> <p>Hence, make sure the temperature of the medium is sufficiently below the ignition temperature of the medium, even when it is compressed to the maximum permissible operating pressure of the pump. The maximum permissible operating pressure of the pump is stated in the technical specifications (chapter 4).</p> <p>If necessary, consider any external sources of energy, such as radiation, that may add heat to the medium.</p> <p>In case of doubt, consult the KNF customer service.</p>
Environmental protection	Store all replacement parts in a protected manner and dispose of them properly in accordance with the applicable environmental protection regulations. Observe the respective national and international regulations. This especially applies to parts contaminated with toxic substances.
EC Directives / Standards	For the purposes of the Machinery Directive 2006/42/EC, pumps are "partly completed machinery," and are therefore to be regarded as not ready for use. Partly completed machinery may not be commissioned until such time as it has been determined that the machine in which the partly completed machinery is to be assembled is in conformity with the provisions of the Machinery Directive 2006/42/EC. The following essential requirements of

Annex I of Directive 2006/42/EC (general principles) are applied and observed:

- General Principles No. 1
- No. 1.1.2. / 1.1.3. / 1.3.1. / 1.3.3. / 1.3.4. / 1.4.1. / 1.5.8 / 1.5.9. / 1.7.4. / 1.7.4.1. / 1.7.4.3.

As these partly completed machinery are OEM-models the power supplies and the equipment for disconnecting and switching-off the partly completed machinery respectively have to be considered when mounting as well as over-current and overload protective gear.

In addition a protection against mechanical parts in motion and hot parts, if existing, has to be provided when mounting.



The pumps conform to the Directive 2011/65/EU (RoHS2).

The pumps conform to the EC Directive 2004/108/EC concerning Electromagnetic Compatibility.

The following harmonized standards have been used:

N 86 AN.12.29 DC-B	N 816 AV.12.29 DC-B	N 838 AN.12.29 DC-B
N 86 AP.12.29 DC-B		N 838 AP.12.29 DC-B
DIN EN 55014-1	DIN EN 55014-1/2	DIN EN 61000-6-2/3
DIN EN 61000-6-2		

Tab. 2

Customer service and repairs

Only have repairs to the pumps carried out by the KNF Customer Service responsible.

Use only genuine parts from KNF for servicing work.

4. Technical Data

Pump materials

N 86 AN.12.29 DC-B

N 838 AN.12.29 DC-B

Assembly	Material
Ribbed plate, intermediate plate, intermediate ring	Aluminium
Working diaphragm	NBR
Safety diaphragm	NBR
Valve plate/sealing	NBR
Diaphragm parts made of steel	Steel

Tab. 3

N 86 AP.12.29 DC-B

N 838 AP.12.29 DC-B

Assembly	Material
Ribbed plate, intermediate plate, intermediate ring	Anodized aluminium
Working diaphragm	EPDM
Safety diaphragm	NBR
Valve plate/sealing	EPDM
Diaphragm parts made of steel	Steel

Tab. 4

N 816 AV.12.29 DC-B

Assembly	Material
Ribbed plate, intermediate plate, intermediate ring	Anodized aluminium
Working diaphragm	FPM
Safety diaphragm	FPM
Valve plates/sealings	FPM
Diaphragm parts made of steel	Steel

Tab. 5

Pneumatic values

N 86 AN.12.29 DC-B

N 86 AP.12.29 DC-B

Parameter	Value
Max. permissible operating pressure [bar g]	1.0
Ultimate vacuum [mbar abs.]	250
Flow rate at atm. pressure [l/min]*	4.5

Tab. 6

*Liters in standard state (1,013 mbar)

N 816 AV.12.29 DC-B

Parameter	Value
Max. permissible operating pressure [bar g]	0.6
Ultimate vacuum [mbar abs.]	250
Flow rate at atm. pressure [l/min]*	11

Tab. 7

*Liters in standard state (1,013 mbar)

N 838 AN.12.29 DC-B

N 838 AP.12.29 DC-B

Parameter	Value
Max. permissible operating pressure [bar g]	0.6
Ultimate vacuum [mbar abs.]	200
Flow rate at atm. pressure [l/min]*	25
Flow rate at atm. pressure and 0.1 V control voltage [l/min]*	4.9

Tab. 8

*Liters in standard state (1,013 mbar)

Pneumatic Connection

Parameter	Value
N 86 A_.12.29 DC-B	Thread size G 1/8
N 816 AV.12.29 DC-B	Thread size G 1/8
N 838 A_.12.29 DC-B	Thread size G 1/8

Tab. 9

Electrical data

N 86 AN.12.29 DC-B

N 86 AP.12.29 DC-B

N 816 AV.12.29 DC-B

Parameter	Value
Electrical data	See type plate

Tab. 10

N 838 AN.12.29 DC-B

N 838 AP.12.29 DC-B

Parameter	Value
Motor type	Brushless DC motor
Voltage [V]	24
Control voltage (only .29 version) [V]	0.1...5*
Max. operating current [A] - for $p > p_{atm.}$ - for $p < p_{atm.}$	1.90 1.80
Starting current	The starting current can be up to 50 % above the maximum operating current.
Starting ramp [ms]	800

Parameter	Value
Max. power consumption of the pump [W]: - for $p > p_{atm.}$ - for $p < p_{atm.}$	45.6 43.2
Maximum permissible mains voltage fluctuations	+/- 10 %
Motor protection class	IP 20
Overcurrent limitation of the motor electronics [A]	7.5

Tab. 11 * further control voltage versions on demand

i The pumps of N 838 A_.12.29 DC-B series are protected against overheating by a temperature sensor on the motor board and equipped with overcurrent protection. If one of these safety functions is triggered or if the maximum blocking time of the rotor is exceeded due to a fault, the pump will be shut down and must be manually reset, as follows:

- ➔ Separate pump from the mains.
- ➔ Remove the cause(s) of the fault before restarting.

Weight

Pump type	Weight (kg)
N 86 A_.12.29 DC-B	approx. 0.7
N 816 AV.12.29 DC-B	approx. 1.5
N 838 A_.12.29 DC-B	approx. 2.5

Tab. 12

Dimensions

Pump type	Value
N 86 A_.12.29 DC-B L x H x W [mm]	85 x 94 x 54
N 816 AV.12.29 DC-B L x H x W [mm]	111 x 132.5 x 60
N 838 A_.12.29 DC-B L x H x W [mm]	137 x 145 x 115

Tab. 13

Other parameters

Parameter	Values
Permissible ambient temperature for pump types N 86 AN.12.29 DC-B and N 838 AN.12.29 DC-B	+ 5 °C to + 50 °C
Permissible ambient temperature for pump types N 86 AP.12.29 DC-B, N 816 AV.12.29 DC-B and N 838 AP.12.29 DC-B	+ 5 °C to + 60 °C
Permissible media temperature	+ 5 °C to + 40 °C
Gas-tightness* of pump head (leak rate)	$< 6 \times 10^{-4}$ mbar l/s**
Maximum permissible ambient relative humidity	80 % for temperatures up to 31 °C, decreasing linearly to 50 % at 40 °C
Max. altitude of site [m above sea level]	2000

Tab. 14

* Perform a leak test in order to ensure gastightness after opening the pump head or after exchanging diaphragms and valve plates/sealings.

** Values valid for helium leak tests

5. Design and function

Design N 86 A_.12.29 DC-B

- 1 Pump head
- 2 Motor
- 3 Base plate
- 4 Pneumatic inlet
- 5 Pneumatic outlet

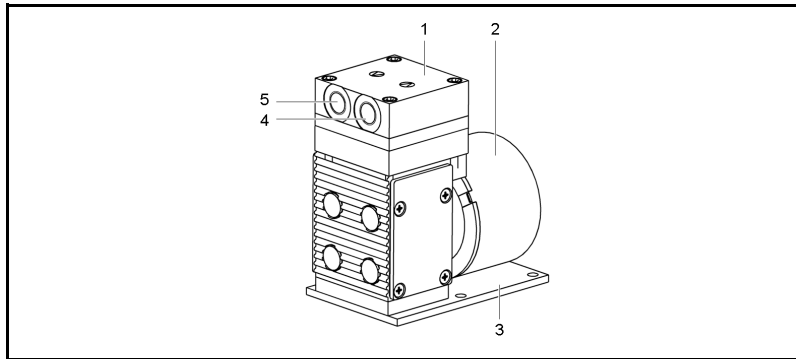

Fig. 1: Double diaphragm pump N 86 AN.12.29 DC-B

Design N 816 AV.12.29 DC-B

- 1 Pump head
- 2 Pneumatic inlet
- 3 Pneumatic outlet
- 4 Motor
- 5 Base plate

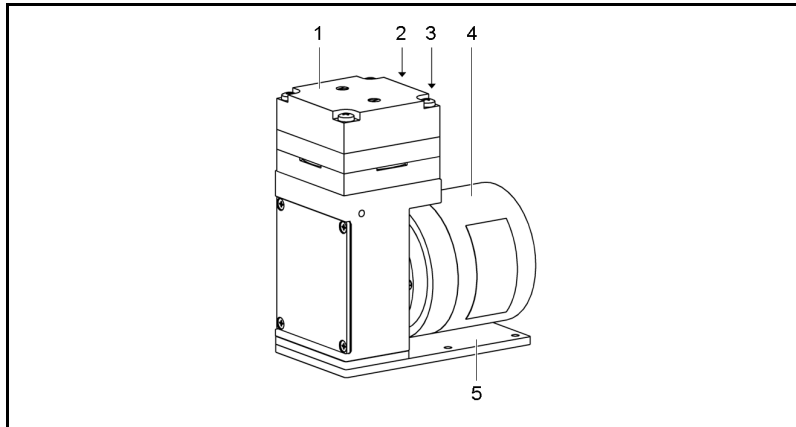

Fig. 2: Double diaphragm pump N 816 AV.12.29 DC-B

Design N 838 A_.12.29 DC-B

- 1 Pump head
- 2 Pneumatic outlet
- 3 Pneumatic inlet
- 4 Electronics cover
- 5 Voltage supply
- 6 Control connections
- 7 Footplate
- 8 Ground connection
- 9 Motor

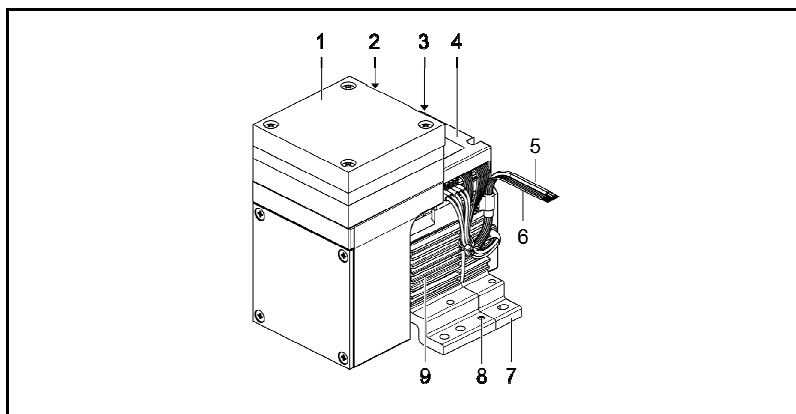

Fig. 3: Double diaphragm pump N 838 AN.12.29 DC-B

Function Double diaphragm pumps

- 1 Outlet valve
- 2 Inlet valve
- 3 Transfer chamber
- 4 Working diaphragm
- 5 Innerspace
- 6 Safety diaphragm
- 7 Eccentric
- 8 Connecting rod
- 9 Pump drive

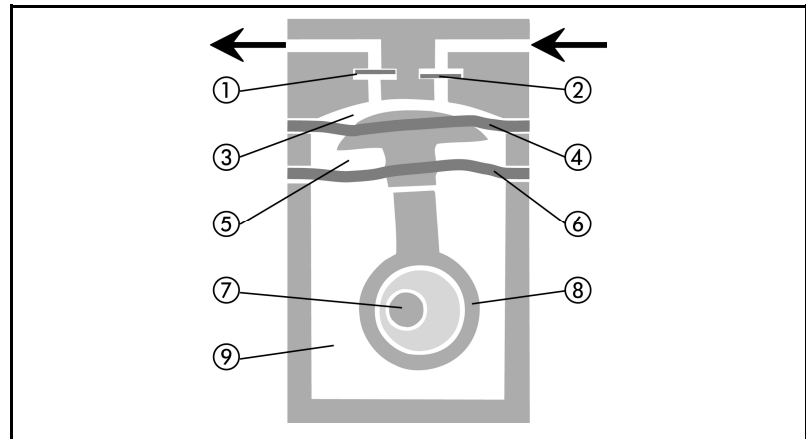

Fig. 4: Pump head

Double diaphragm pumps transfer, compress (depending on pump version) and evacuate gases and vapors.

The elastic working diaphragm (4) is moved up and down by the eccentric (7) and the connecting rod (8). In the downward stroke it aspirates the gas to be transferred via the inlet valve (2). In the upward stroke, the working diaphragm presses the medium out of the pump head via the outlet valve (1). The transfer chamber (3) is hermetically separated from the pump drive (9) by the working diaphragm.

A second diaphragm (safety diaphragm (6)) is located underneath the working diaphragm. This second diaphragm is under less mechanical stress when the pump is operating. If gas should leak at the working diaphragm, it will still remain inside the pump space.

6. Installation and connection

Only install and operate the pumps under the operating parameters and conditions described in Chapter 4, Technical data.

Observe the safety precautions (see Chapter 3).

6.1. Installation of the pump

	→ Before installation, store the pump at the installation location to bring it up to ambient temperature.
Mounting dimensions	→ See fig. 5, p. 13 (pump series N 86 A_.12.29 DC-B), fig. 6, p. 13 (pump series N 816 AV.12.29 DC-B) and fig. 7, p. 14 (pump series N and N 838 A_.12.29 DC-B) for the mounting dimensions.
Immediate environment	→ When installing the pump, ensure that no flammable objects or objects subject to thermal deformation are located in the immediate vicinity of hot pump parts (head, motor).
Installation position	→ The pump may be installed in any position. Use metal screws to fasten the pump at the indicated attachment points.
Cooling air flow	→ When installing the pump, ensure an adequate flow of cooling air.
Attach connection cables	→ Fasten the connection cables so that: <ul style="list-style-type: none"> ▪ the cables do not contact moving parts ▪ the cables will not chafe or be damaged on sharp edges or corners ▪ no pulling or pushing forces are exerted on the cable's connection points (strain relief).
Protection against touching and foreign objects	Take protective measures against touching and foreign objects which could enter the pump.
Installation location	<p>→ Make sure that the installation location is dry and the pump is protected against rain, splash, hose and drip water.</p> <p>i The IP protection class of the pump motor is indicated on the type plate.</p> <p>→ Install the pump at the highest point in the system to prevent condensate from collecting in the pump head.</p> <p>→ Protect the pump from dust.</p> <p>→ Protect the pump from exposure to fats and oils.</p> <p>→ Protect the pump from vibrations and jolts.</p>

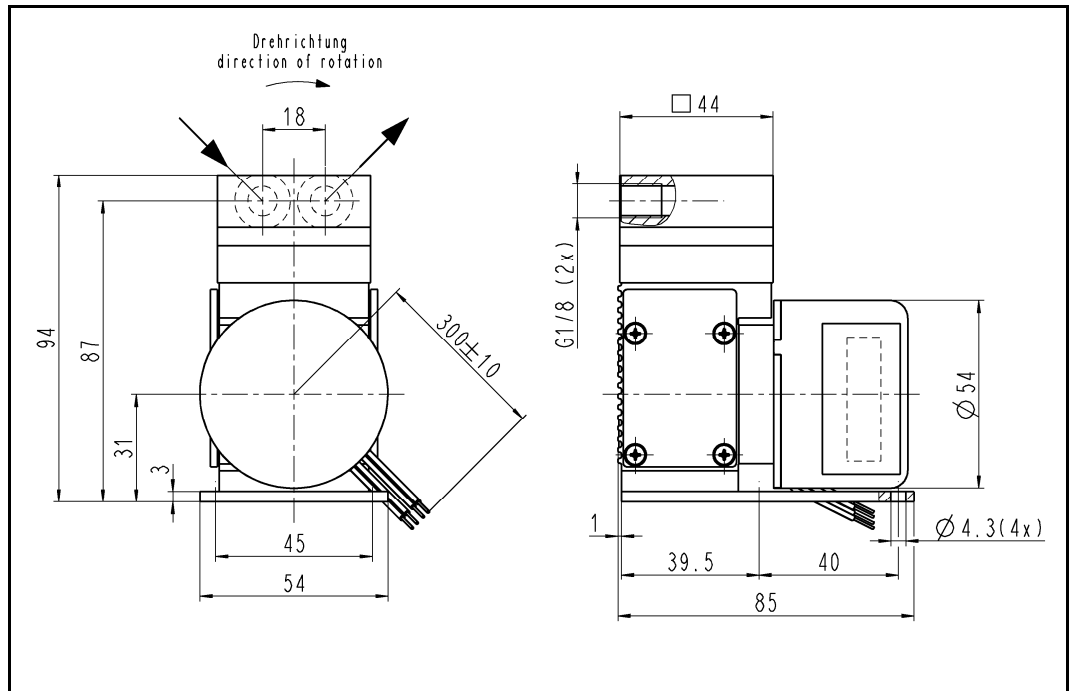

Fig. 5: Mounting dimensions pump series N 86 A_12.29 DC-B
(All dimensional tolerances conform to DIN ISO 2768-1, Tolerance Class V)

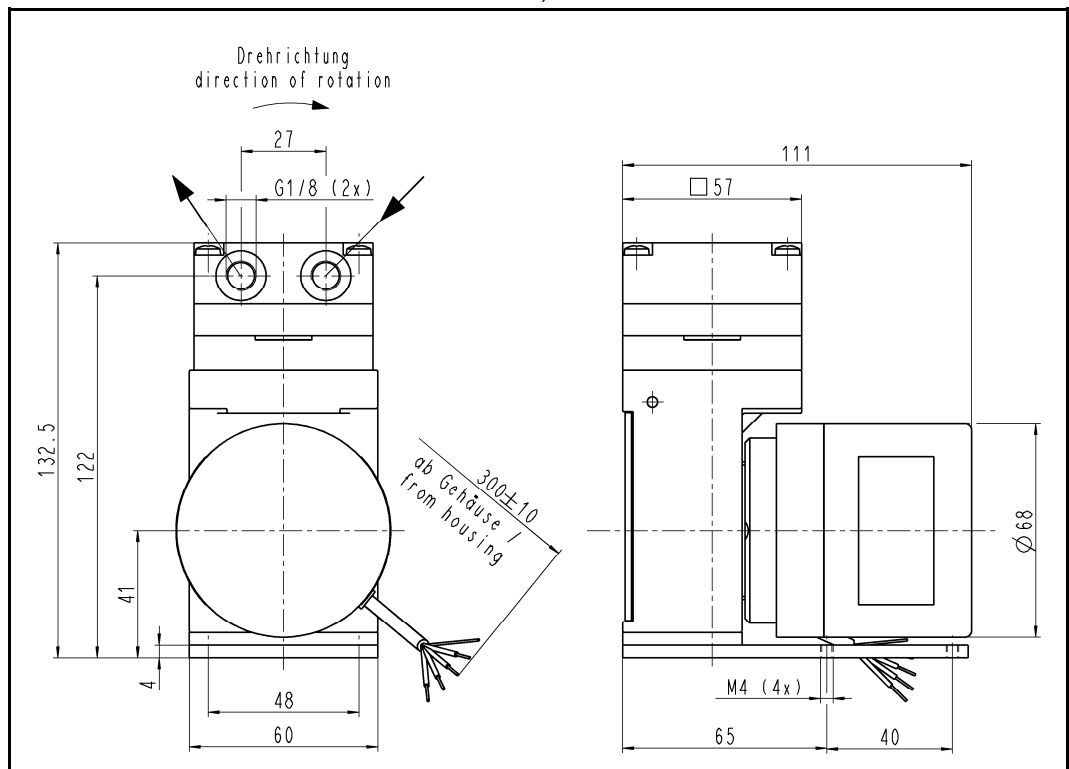

Fig. 6: Mounting dimensions pump series N 816 AV.12.29 DC-B
(All dimensional tolerances conform to DIN ISO 2768-1, Tolerance Class V)

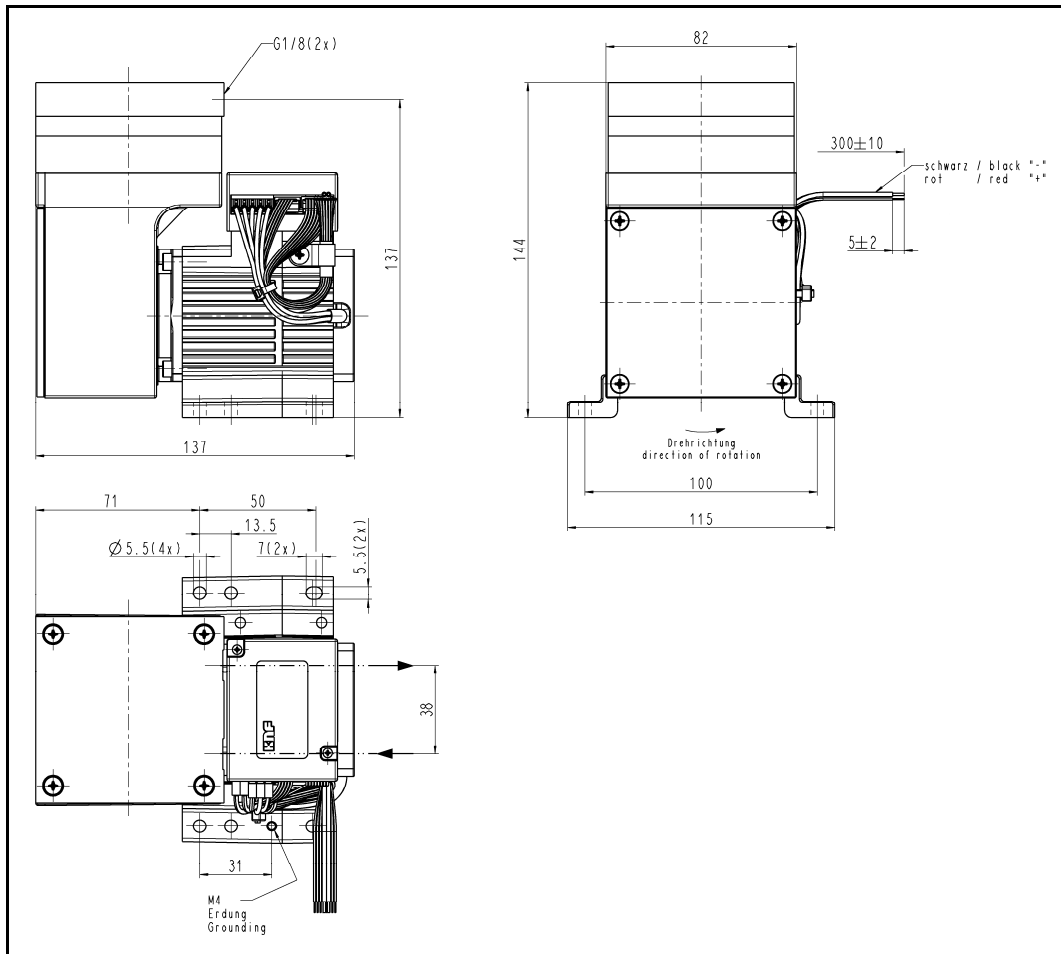

Fig. 7: Mounting dimensions pump series N 838 A_12.29 DC-B
 (All dimensional tolerances conform to DIN ISO 2768-1,
 Tolerance Class V)

6.2. Electrical connection

- Only have the pump connected by an authorized specialist.
- Only have the pump connected when the power supply is disconnected.
- When connecting the device to a power source, the relevant standards, directives, regulations, and technical standards must be observed.
- In the electrical installation, arrangements (complying with EN 60335-1) must be made for disconnecting the pump motor from the electrical supply.
- It is recommended that an additional “Emergency Stop” switch is installed.
- The pump must be installed so that contact with live parts is impossible.

Connecting pump

1. Compare the supply data with the data on the motor-plate. For operating current see type plate.
 - i** The voltage must not vary by more than + 10% and - 10% from that shown on the type-plate. Refer to the following tables for limit values when setting speed and flow rate through the supply voltage.
2. Connect motor cable
 - i** Observe proper polarity. Incorrect polarity will damage the electronics!
 - i** For N 838 A_.12.29 DC-B:
The supply wires have inverse-polarity protection on the motor board for this purpose, while the control-voltage wires do not have this protection function.
 - i** For N 838 A_.12.29 DC-B:
Control voltage may only be applied if the motor controller is supplied with operating voltage. Otherwise damages can occur on the motor controller.

Pump series N 86 A_.12.29 DC-B

4-lead motor (standard version)

Colour of cable	Functions
Red	V+ 12 V version: 10–15 V 24 V version: 14–28 V
Blue	Ground
White	Speed input Vctrl 0–5 V DC
Green	Frequence output (6 pulses per revolution)
— — —	Shield

Tab. 15

2- lead motor (optional version)

Colour of cable	Functions
Red	V+ 12 V version: 10–15 V 24 V version: 14–28 V
Blue	Ground

Tab. 16

Supplemental circuit

To ensure interference suppression according to EN 55014-1:1993 + A1:1997 Emissions (product family standard) pumps of the series N 86 A_.12 DC-B must be equipped with a supplemental circuit. The supplemental circuit must be installed as close as possible to the motor.

The supplemental circuitry is not necessary if a voltage supply has a suppression of > 20 dB at 150 kHz and 0 dB at 1 MHz.

The supplemental circuit must be structured according to the following electrical diagram and the components defined therein in order to achieve the required level of suppression (Fig. 8).

- C1: Capacitor 1 μ F
- C2: Capacitor 1000 μ F
- L1: Choke coil 6 μ H

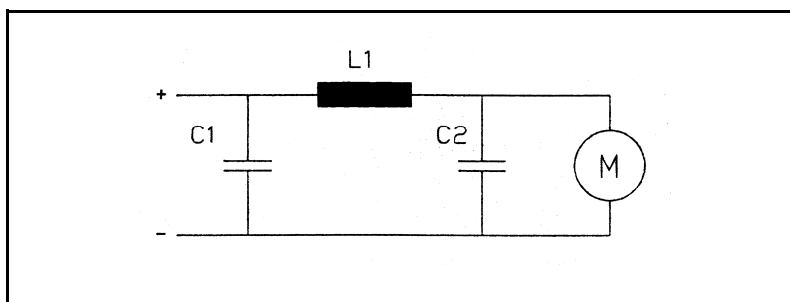

Fig. 8: Supplemental electronic circuit for pumps N 86 A_.12.29 DC-B

Pump series N 816 AV.12.29 DC-B

4-lead motor (standard version)

Colour of cable	Functions
Red	V+ 24 V version: 14–30 V
Black	Ground
White	Speed input Vctrl 0–5 V DC
Green	Frequence output (36 pulses per revolution)
---	Shield

Tab. 17

2- lead motor (optional version)

Colour of cable	Functions
Red	V+ 24 V version: 14–30 V
Black	Ground

Tab. 18

Supplemental circuit

To ensure interference suppression according to EN 55014-1:1993 + A1:1997 Emissions and EN 55014-2 (interference immunity)

(product family standard) pumps of the series N 816 AV.12 DC-B must be equipped with a supplemental circuit. The supplemental circuit must be installed as close as possible to the motor.

The supplemental circuit must be structured according to the following electrical diagram and the components defined therein in order to achieve the required level of suppression (Fig. 9).

C1: Capacitor 1000 μ F

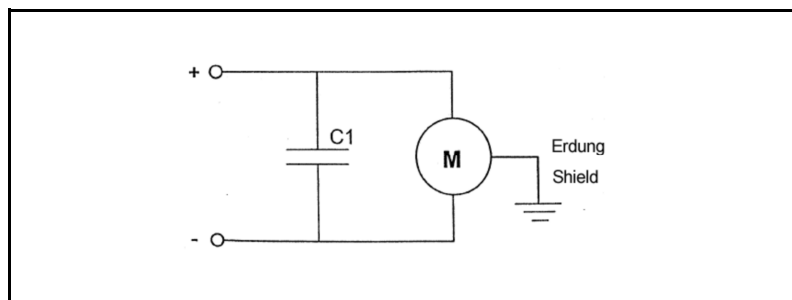

Fig. 9: Supplemental electronic circuit for pumps N 816 AV.12.29 DC-B

Pump series N 838 A .12.29 DC-B

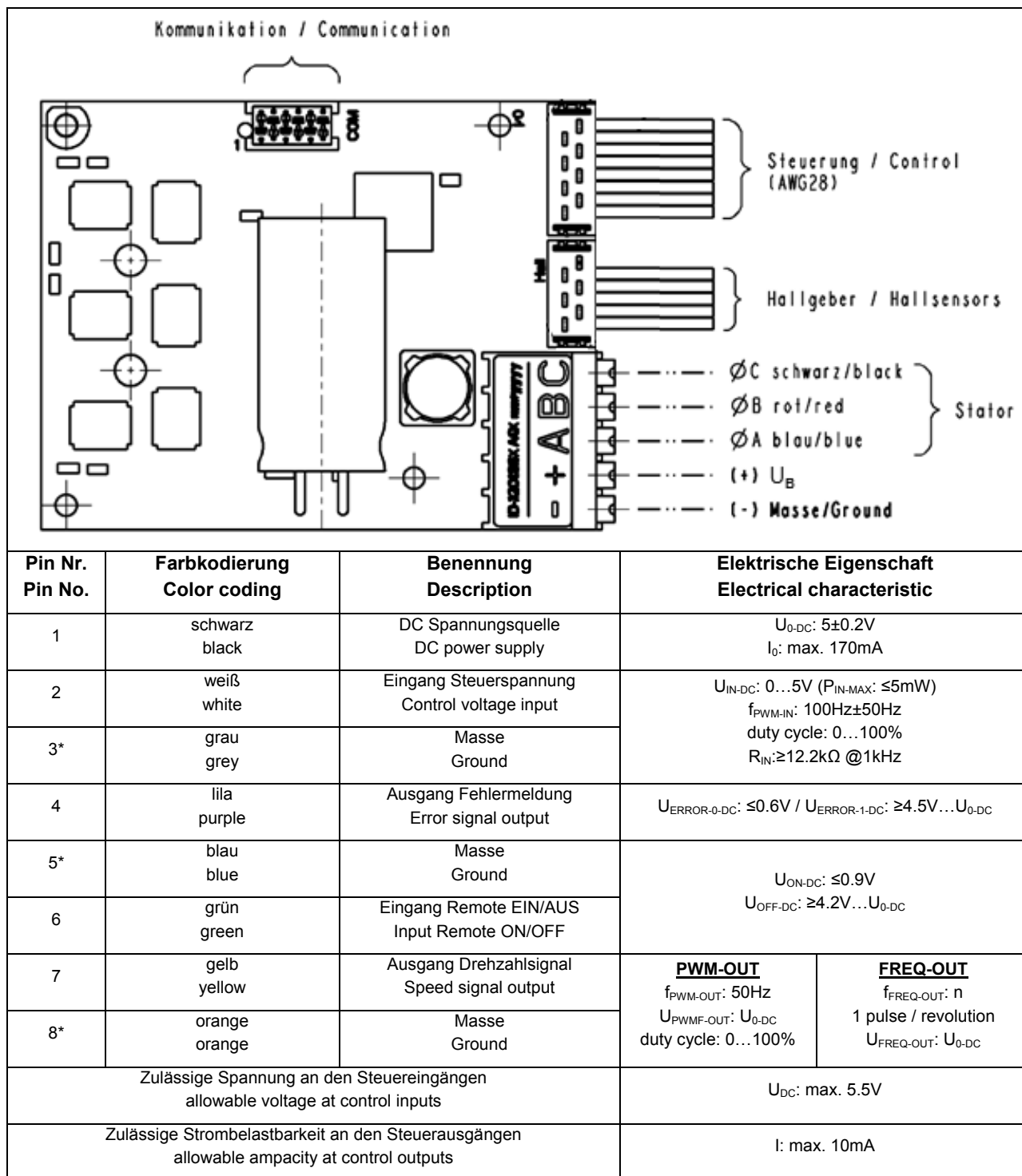

Fig. 10: Connection plan motor electronics

* Ground Pin 3, 5 and 8 are connected with each other

i If Pin 1 is simultaneously used as control voltage specification for Pin 2, please contact the KNF customer services (see last page for telephone number).

6.3. Pneumatic connection

- | | |
|----------------------|--|
| Connected components | → Only connect components to the pump which are designed for the pneumatic data of the pump (see Chapter 4, Technical data). |
| Pump exhaust | → If the pump is used as a vacuum pump, safely discharge the pump exhaust at the pump's pneumatic outlet. |

Connecting pump

i A marking on the pump head shows the direction of flow.

1. Remove the protective plugs from the hose connection threads.
2. Connect the suction line and pressure line.
3. Lay the suction and pressure line at a downward angle to prevent condensate from running into the pump.

6.4. Install monitoring device



WARNING

Danger of dangerous gas mixtures during operation of the pump if the working diaphragm ruptures

Depending on the medium being pumped, a rupture of the working diaphragm may produce a potentially dangerous mixture when the medium mixes with the air in the innerspace between the working diaphragm and the safety diaphragm.

- KNF recommends monitoring pressure and flow rate of the pneumatic system in which the pump is integrated.
- If pressure or flow rate change without apparent reason, immediately switch off the pump and check for damages.
- Immediately stop the pump if the working diaphragm ruptures. The working diaphragm and the safety diaphragm must be replaced before continuing with operation (see chapter 8, Maintenance).

7. Operation

7.1. General

- Only operate the pumps under the operating parameters and conditions described in Chapter 4, Technical data.
- Make sure the pumps are used properly (see section 2.1).
- Make sure the pumps are not used improperly (see section 2.2).
- Observe the safety precautions (see Chapter 3).
- The pumps are intended for installation. Before putting them into service it must be established that machinery or equipment in which they are installed meets the relevant regulations.

**WARNING**

Hazard of the pump head bursting due to excessive pressure increase

- Do not exceed max. permissible operating pressure (see Chapter 4, Technical data).
- Monitor pressure during operation.
- If the pressure exceeds the maximum permissible operating pressure, immediately switch off pump and eliminate fault (see Chapter 9. Troubleshooting).
- Only throttle or regulate the air or gas quantity in the suction line to prevent the maximum permissible operating pressure from being exceeded.
- If the air or gas quantity in the pressure line is throttled or regulated, make sure that the maximum permissible operating pressure is not exceeded.
- Ensure that the pump outlet is not closed or constricted.

i Excessive pressure (with all of the related hazards) can be prevented by placing a bypass line with a pressure-relief valve between the pressure and suction sides of the pump. For further information, contact our technical adviser (see last page for telephone number).

**DANGER**

Depending on the pumped medium, dangerous gas mixtures may form if the working diaphragm ruptures

If the working diaphragm ruptures, the medium will mix with the air located in the innerspace between the working diaphragm and the safety diaphragm.

- ➔ If the working diaphragm ruptures, stop the pump immediately. A rupture of the working diaphragm can be detected by the pump's reduced pneumatic performance and a pressure change within the pneumatic system.
- ➔ The working diaphragm and the safety diaphragm must be replaced before continuing with operation (see chapter 8, Maintenance).

Pump standstill	➔ With the pump at a standstill, open pressure and suction lines to normal atmospheric pressure.
Overload protection	<p>For pumps with electrical and thermal overload protection (series N 838 A_.12.29 DC-B): when the operation of the pump is interrupted by the overload protection, the pump can be restarted after disconnecting it from the voltage supply and then reconnecting.</p> <p>➔ Take all necessary care to prevent this leading to a dangerous situation.</p>
Switching on the pump	<p>i For N 86 A_.12.29 DC-B und N 816 AV.12.29 DC-B: Do not allow the pumps to start against pressure or vacuum. If you experience a brief power interruption, check for the presence of pressure or vacuum before restarting. If a pump starts against pressure or vacuum, it may block.</p> <p>➔ Install overload switch</p> <p>➔ Make sure that there is no pressure in the hoses before switching on the pump.</p> <p>i For N 838 A_.12.29 DC-B: The pumps may start against pressure or vacuum. This is also allowed if you experience a brief power interruption.</p>
Switching off the pump/removing from operation	Restore the system to normal atmospheric pressure (release pneumatic pressure in pump).

7.2. Control functions

7.2.1. Speed control

Pump series N 86 A_ .12.29 DC-B and N 816 AV.12.29 DC-B

The pumps' motor speed and therefore their flow rates can be set and at some pump versions controlled (see Tab. 19).

Pump types	Speed
N 86 A_ .12.29 DC-B with 4-lead motor (standard version)	- Control through input signal 0 to 5 V DC
N 86 A_ .12.29 DC-B with 2-lead motor (optional version)	- Regulate through supply voltage
N 816 AV.12.29 DC-B with 4-lead motor (standard version)	- Control through input signal 0 to 5 V DC
N 816 AV.12.29 DC-B with 2-lead motor (optional version)	- Regulate through supply voltage

Tab. 19

Pump series N 838 A_ .12.29 DC-B

The motor drives the pump at a changeable speed between n_{min} and n_{max} . Speed is specified via the control voltage.

7.2.1.1. Speed input (pump series N 838 A_ .12.29 DC-B)

Speed range The speed range of $n_{min} \dots n_{max}$ is shown scaled to the control voltage U_c :

- $U_{c_{min}}$: 0.1V
- $U_{c_{max}}$: 5.0V

If the control voltage is less than $U_{c_{min}}$, the motor is OFF.

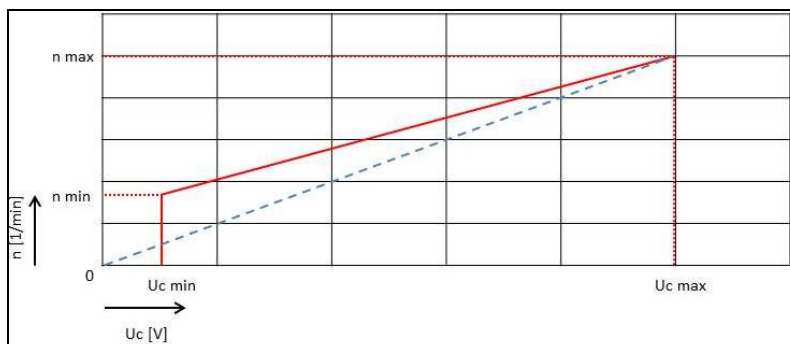

Fig. 11: Control-voltage/speed curve (standard)

Speed specification Speed is specified through the 8-pin controller connection, Pin 2 (see Table in Fig. 10).

Optional settings for control voltage input

The following additional settings can be made at the factory upon request:

- Modify control voltage values U_{cmin} and U_{cmax}
- If the control voltage is less than U_{cmin} , the motor will be ON.

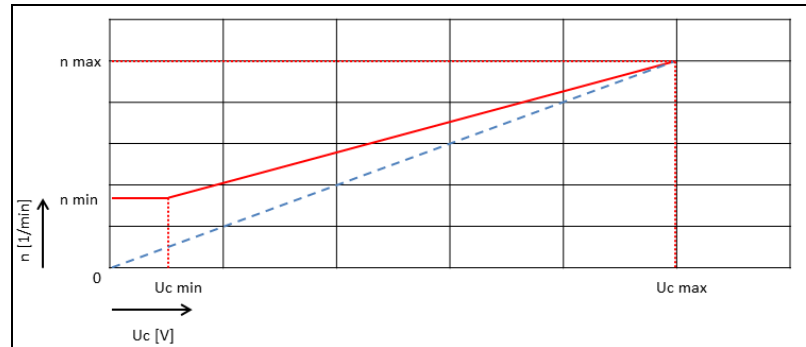

Fig. 12: Scaled control-voltage/speed curve (optional)

7.2.1.2. Speed output (pump series N 838 A_12.29 DC-B)

Speed output

Speed is outputted through the 8-pin controller connection (Pin 7, see Table in Fig. 10).

The motor controller generates speed-synchronized pulse-width modulation (see Fig. 13).

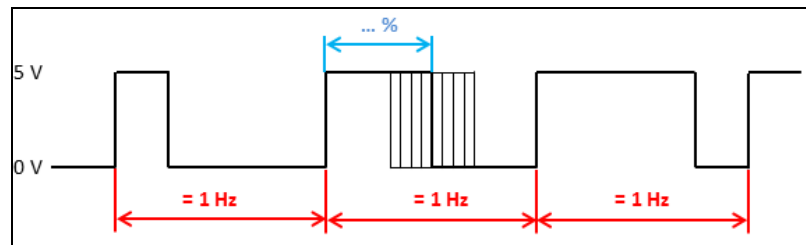

Fig. 13: Analog speed output (standard)

Optional speed output

The motor controller generates a speed-synchronized right-angle frequency with 5V TTL level (see Fig. 14).

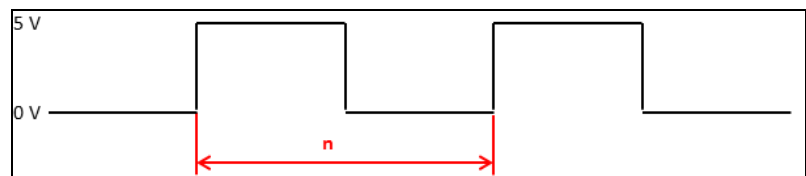

Fig. 14: Digital speed output (optional)

**7.2.2. Remote ON/OFF
(pumpe series N 838 A_.12.29 DC-B)**

Remote ON/OFF Remote ON/OFF is through an 8-pin controller connection (Pin 6, see Fig. 10).

i To start the motor, Pin 6 must be bridged to the ground of the controller connection.

**7.2.3. External activation
(pump series N 838 A_.12.29 DC-B, optional)**

External activation If desired, the pump motor can be activated externally. This requires a special setting at the factory (see final page for contact address).

External activation is through the 6-pin communication connection (see Fig. 10 above).

Connector type: Micro-Match Female Top Entry
Part no.: 7-215079-6

i When the motor is activated externally, the control inputs are inactive.

Connection communication plug (see Fig. 10 top)

- PIN 1 – do not connect
- PIN 2 - do not connect
- PIN 3 – GND
- PIN 4 – 5V (max. 50 mA)
- PIN 5 – TX MBLC
- PIN 6 - RX MBLC

Motor connection options – external control unit

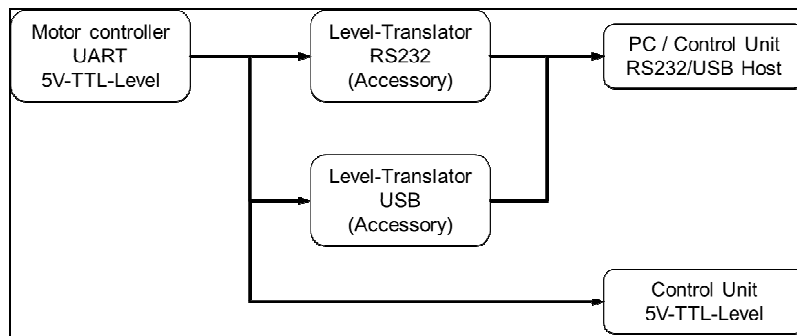

Fig. 15: External activation options (optional)

The following motor functions can be controlled:

- Motor remote ON/OFF
In the factory condition, the motor is OFF when operating voltage is applied. However, as an option the motor can be ON when operating voltage is applied.
- Motor speed
Setting motor speed within speed limits n_{min} and n_{max} .
- Read-out of the following process parameters:
 - Actual/Nominal motor speed

- Control limit of motor speed
- Operating current of the motor
- Temperature of the motor controller
- Fault status
- Software version number

Interface protocol The connection between the PC and motor controller can be operated as an RS-232 interface. Accordingly, in the operating system it is managed as an additional COM connection and can be addressed with conventional terminal software.

Interface configuration

- Baud rate: 57600 bits/s
- Data bits: 8
- Parity: none
- Stop bits: 1
- Flow control: none

Tables 20 to 22 contain the necessary command sets, shown as ASCII characters. When transmitting, the commands must be followed by ASCII character <CR> (carriage return, decimal value 013). The underlined expressions are not characters, but symbols as explained in table 16.

Parameter	Command*	Function	Reply
Motor	dB	Start	<u>S</u> ; <u>E</u>
	dE	Stop	<u>S</u> ; <u>E</u>
Speed	dSnnnn [nnnn = speed value]	Set nominal speed	<u>ns</u> ; <u>E</u>

Tab. 20: Control commands

* A pause of at least 25 ms is required after the "dB" instruction set.

Parameter	Command	Reply
Actual motor speed; operating current of the motor; temperature of the motor controller; Fault status	pP	<u>ni</u> ; <u>ii</u> , <u>ti</u> , <u>ei</u> ; <u>E</u>
Fault status (single value)	gP	<u>ei</u> ; <u>E</u>
Nominal motor speed	gS	<u>ns</u> ; <u>E</u>
Minimum possible motor speed	gSl	<u>nl</u> ; <u>E</u>
Maximum possible motor speed	gSh	<u>nh</u> ; <u>E</u>
Software version number	iV	<u>V</u> ; <u>E</u>

Tab. 21: Read commands

Symbol	Interpretation	Meaning
<u>E</u>	Announcement of completion	0 command cannot be completed
		1 command completed
		? command unclear
<u>S</u>	Status message	For service only
<u>V</u>	Version number	e.g. 01.018
<u>ni</u>	Actual motor speed	Value [min ⁻¹]
<u>ns</u>	Nominal motor speed	Value [min ⁻¹]
<u>nl</u>	Minimum nominal motor speed	Value [min ⁻¹]
<u>nh</u>	Maximum nominal motor speed	Value [min ⁻¹]
<u>ii</u>	operating current of the motor	Value [mA]
<u>ti</u>	temperature of the motor controller	Value [°C]
<u>ei</u>	Fault status	16 bit value

Tab. 22: Symbols

The symbols represent the ASCII codes of sequences of digits any length. The controller processes input values only as whole numbers (integers).

Interface level

i See p. 18 for pin assignment of the motor controller's communication plug.

Parameter	Value
Rx KNF MBLC	Low: 0V...0.9V High: 4.2V...5.2V
Tx KNF MBLC	Low: 0V...0.6V High: 4.5V...5.2V

Tab. 23

8. Servicing

8.1. Servicing schedule

Component	Servicing interval
Pump	- Regular inspection for external damage or leaks
Working diaphragm, safety diaphragm and valve plates/ sealings	- Replace if pump's pressure or flow rate change without apparent reason - Replace at the latest, when pump output decreases

Tab. 24

8.2. Cleaning

i When cleaning, make sure that no liquids enter the inside of the housing.

8.2.1. Flushing pump

→ Flush the pump under atmospheric conditions some minutes with air (or, if necessary for safety reasons, with an inert gas) prior to switch-off.

8.2.2. Cleaning pump

Conditions

- Motor disconnected from mains and de-energized



WARNING

Health hazard due to dangerous substances in the pump!

Depending on the substance transferred, caustic burns or poisoning are possible.

- Wear protective clothing if necessary, e.g. protective gloves.
- Clean pump with suitable measures.



CAUTION

Danger of burns from hot pump parts

The pump head or motor may be hot even after the pump has been shut off.

- Allow the pump to cool off after operation.

- Only use solvents for cleaning if the head materials cannot be attacked (check the resistance of the material).
- If compressed air is available, blow out the components.

8.3. Replacing working diaphragm, safety diaphragm and valve plates/sealings

Conditions

- Motor disconnected from mains and de-energized
- Pump free of dangerous substances
- Tubes/pipes removed from pump's pneumatic inlet and outlet



WARNING

There is the danger that hazardous gas mixtures will form and that the pumped media will leak from the pump while the pump is in operation, if the safety diaphragm is not replaced at the same time as the working diaphragm.

- ➔ Always replace the safety diaphragm at the same time the working diaphragm is replaced.

-
- ➔ Always replace the working diaphragm, safety diaphragm and valve plates/sealings together to maintain the pump performance.



WARNING

Health hazard due to dangerous substances in the pump!

Depending on the substance transferred, caustic burns or poisoning are possible.

- ➔ Wear protective clothing if necessary, e.g. protective gloves.
 - ➔ Clean pump with suitable measures.
-

8.3.1. N 86 A_.12.29 DC-B

Spare parts

Spare part*	Position**	Quantity
Working diaphragm	(5)	1
Safety diaphragm	(7)	1
Valve plate/sealing	(3)	1

Tab. 25

* According to spare parts list, chapter 10

** According to Fig. 16

Tools and material

Quantity	Tools/Material
1	Phillips screwdriver No. 1
1	Wrench for safety diaphragm N 86.12*
1	Felt-tip pen

Tab. 26

* according to accessories list, chapter 10

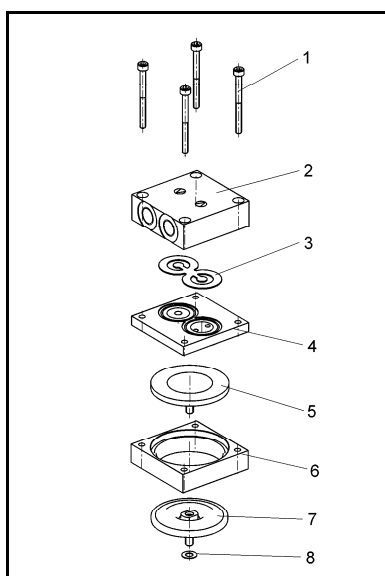
Removing pump headFig. 16: N 86 A_.12.29 DC-B:
Parts of pump head

1. Mark the position of ribbed plate (2), intermediate plate (4), intermediate ring (6) and pump housing relatively to each other by a drawing line with a felt-tip pen to ensure proper assembly.
2. Remove the ribbed plate:
 - i** Set down the ribbed plate carefully to avoid damaging its sealing edge.
 Unscrew the four screws (1) and remove the ribbed plate (2).
3. Remove the intermediate plate (4).
 - i** Set down the intermediate plate carefully to avoid damaging its sealing edge.
 The working diaphragm (5) is visible.

Replacing working diaphragm and safety diaphragm

1. Lift the working diaphragm (5) by the opposing side edges, grasp it and unscrew it in the counter-clockwise direction.
2. Remove intermediate ring (6) from pump housing.
3. Unscrew safety diaphragm:
 - i** Make sure the diaphragm spacer(s) (8) do not fall into the pump housing.
 Unscrew the safety diaphragm (7) in the counter-clockwise direction by using the wrench for safety diaphragm.
4. Remove the diaphragm spacer(s) (8) from the threaded pin of the safety diaphragm and keep in a safe place.
5. Carefully clean on the compressor housing the surface which contacts the safety diaphragm (7) and check it for damage.
6. Push the diaphragm spacer(s) (8) onto the threaded pin of the new safety diaphragm (7); screw the safety diaphragm clockwise onto the connecting rod (connecting piece between drive shaft and safety diaphragm) and tighten it tight by using the wrench for safety diaphragm.
7. Clean intermediate ring (6) and check its sealing edges for damage.

8. Place the intermediate ring (6) onto pump housing in accordance with the felt-tip pen marking.
9. Screw the working diaphragm (5) clockwise onto the safety diaphragm (7) and tighten hand-tight.

Replacing valve plate/sealing

1. Remove the valve plate/sealing (3) from the intermediate plate (4).
2. Check the intermediate plate (4) and ribbed plate (2) for soiling and damage. Clean the parts if necessary. Make sure that the sealing edges of the ribbed plate (2) and intermediate plate (4) are undamaged.
3. Contact KNF in case of roughness, scratches and corrosion. Order and replace damaged parts.
4. Insert valve plate/sealing:
 - i** Upper and lower side of the valve plate/sealing are identical.Lay new valve plate/sealing (3) in the valve seat of the intermediate plate (4).
5. Dispose of the old working diaphragm, safety diaphragm and valve plate/sealing properly.

Mounting pump head

1. Place intermediate plate (4) on the intermediate ring (6) in accordance with the felt-tip pen marking.
 2. Place the ribbed plate (2) on the intermediate plate (4) in accordance with the felt-tip pen marking.
 3. Check the centering of the ribbed plate (2) by moving it slightly from side to side.
 4. Screw in the screws (1) and tighten first only slightly diagonally, then tight.
- i** Perform a leak test in order to ensure the required gastightness of the pump head after maintenance.

8.3.2. N 816 AV.12.29 DC-B

Spare parts

Spare part*	Position**	Quantity
Working diaphragm	(5)	1
Safety diaphragm	(7)	1
Valve plate	(3)	2
O-ring	(4)	2

Tab. 27

* According to spare parts list, chapter 10

** According to Fig. 17.

Tools and material

Quantity	Tools/Material
1	Phillips screwdriver No. 1
1	Wrench for safety diaphragm N 86.12*
1	Felt-tip pen

Tab. 28

* according to accessories list, chapter 10

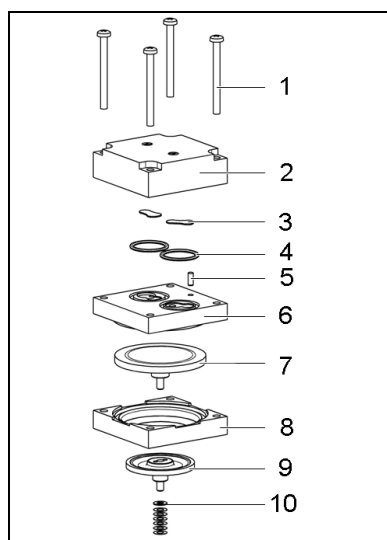
Fig. 17: N 816 AV.12.29 DC-B:
Parts of pump head**Removing pump head**

1. Mark the position of ribbed plate (2), intermediate plate (6), intermediate ring (8) and pump housing relatively to each other by a drawing line with a felt-tip pen to ensure proper assembly.
2. Remove the ribbed plate:
 - i** Set down the ribbed plate carefully to avoid damaging its sealing edge.
 Unscrew the four screws (1) and remove the ribbed plate (2).
3. Remove the intermediate plate (6).
 - i** Set down the intermediate plate carefully to avoid damaging its sealing edge.
 The working diaphragm (7) is visible.

Replacing working diaphragm and safety diaphragm

1. Lift the working diaphragm (7) by the opposing side edges, grasp it and unscrew it in the counter-clockwise direction.
2. Remove intermediate ring (8) from pump housing.
3. Unscrew safety diaphragm:
 - i** Make sure the diaphragm spacer(s) (10) do not fall into the pump housing.
 Unscrew the safety diaphragm (9) in the counter-clockwise direction by using the wrench for safety diaphragm.
4. Remove the diaphragm spacer(s) (10) from the threaded pin of the safety diaphragm and keep in a safe place.
5. Carefully clean on the compressor housing the surface which contacts the safety diaphragm (9) and check it for damage.
6. Push the diaphragm spacer(s) (10) onto the threaded pin of the new safety diaphragm (9); screw the safety diaphragm clockwise onto the connecting rod (connecting piece between drive shaft and safety diaphragm) and tighten it tight by using the wrench for safety diaphragm.

7. Clean intermediate ring (8) and check its sealing edges for damage.
8. Place the intermediate ring (8) onto pump housing in accordance with the felt-tip pen marking.
9. Screw the working diaphragm (7) clockwise onto the safety diaphragm (9) and tighten hand-tight.

Replacing valve plates/O-rings

1. Remove the valve plates (3) and O-rings (4) from the intermediate plate (6).
2. Check the intermediate plate (6) and ribbed plate (2) for soiling and damage. Clean the parts if necessary. Make sure that the sealing edges of the ribbed plate (2) and intermediate plate (6) are undamaged.
3. Contact KNF in case of roughness, scratches and corrosion. Order and replace damaged parts.
4. Insert valve plates:
 - i** Upper and lower side of the valve plates are identical.
 - i** Orientation of the valve plates:
The broader part of the valve plate fits the smaller part of the valve seat.
Lay new valve plates (3) in the valve seat of the intermediate plate (6).
5. Insert O-rings:
 - i** Upper and lower side of the O-rings are identical.
Lay new O-rings (4) in the intermediate plate (6).
6. Dispose of the old working diaphragm, safety diaphragm, valve plates and O-rings properly.

Mounting pump head

1. Place intermediate plate (6) on the intermediate ring (8) in accordance with the felt-tip pen marking.
2. Place the ribbed plate (2) on the intermediate plate (6) in accordance with the felt-tip pen marking or according to the position specification by the parallel pin (5).
3. Check the centering of the ribbed plate (2) by moving it slightly from side to side.
4. Screw in the screws (1) and tighten first only slightly diagonally, then tight.
 - i** Perform a leak test in order to ensure the required gastightness of the pump head after maintenance.

8.3.3. N 838 A_.12.29 DC-B

Spare parts

Spare part*	Position**	Quantity
Working diaphragm	(7)	1
Safety diaphragm	(9)	1
Valve plate/sealing	(4)	2

Tab. 29

* According to spare parts list, chapter 10

** According to Fig. 18

Tools and material

Quantity	Tools/Material
1	Phillips screwdriver No. 1
1	Wrench for safety diaphragm N 838.12*
1	Felt-tip pen

Tab. 30

* according to accessories list, chapter 10

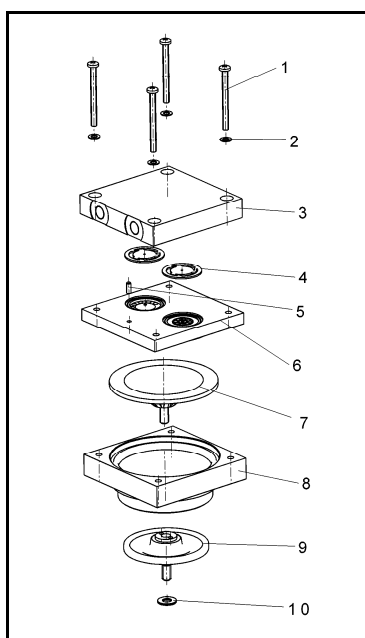

Fig. 18: N 838 A_.12.29 DC-B:
Parts of pump head

Removing pump head

1. Mark the position of ribbed plate (3), intermediate plate (6), intermediate ring (8) and pump housing relatively to each other by a drawing line with a felt-tip pen to ensure proper assembly.
2. Remove the ribbed plate:
 - i** Set down the ribbed plate carefully to avoid damaging its sealing edge.
 Unscrew the four screws (1) and remove the ribbed plate (3).
3. Remove the intermediate plate (6).
 - i** Set down the intermediate plate carefully to avoid damaging its sealing edge.
 The working diaphragm (7) is visible.

Replacing working diaphragm and safety diaphragm

1. Lift the working diaphragm (7) by the opposing side edges, grasp it and unscrew it in the counter-clockwise direction.
2. Remove intermediate ring (8) from pump housing.
3. Unscrew safety diaphragm:
 - i** Make sure the diaphragm spacer(s) (10) do not fall into the pump housing.
 Unscrew the safety diaphragm (9) in the counter-clockwise direction by using the wrench for safety diaphragm.
4. Remove the diaphragm spacer(s) (10) from the threaded pin of the safety diaphragm and keep in a safe place.
5. Carefully clean on the compressor housing the surface which contacts the safety diaphragm (9) and check it for damage.
6. Push the diaphragm spacer(s) (10) onto the threaded pin of the new safety diaphragm (9); screw the safety diaphragm clockwise onto the connecting rod (connecting piece between drive shaft and safety diaphragm) and tighten it tight by using the wrench for safety diaphragm.
7. Clean intermediate ring (8) and check its sealing edges for damage.

8. Place the intermediate ring (8) onto pump housing in accordance with the felt-tip pen marking.
9. Screw the working diaphragm (7) clockwise onto the safety diaphragm (9) and tighten hand-tight.

Replacing valve plates/sealings

1. Remove the valve plates/sealings (4) from the intermediate plate (6).
2. Check the intermediate plate (6) and ribbed plate (3) for soiling and damage. Clean the parts if necessary. Make sure that the sealing edges of the ribbed plate (3) and intermediate plate (6) are undamaged.
3. Contact KNF in case of roughness, scratches and corrosion. Order and replace damaged parts.
4. Insert valve plates/sealings:
i Upper and lower side of the valve plates/sealings are identical.
Lay new valve plates/sealings (4) in the valve seat of the intermediate plate (6).
5. Dispose of the old working diaphragm, safety diaphragm and valve plates/sealings properly.

Mounting pump head

1. Place intermediate plate (6) on the intermediate ring (8) in accordance with the felt-tip pen marking.
2. Place the ribbed plate (3) on the intermediate plate (6) in accordance with the felt-tip pen marking. Position is indicated by alignment pin (5).
3. Check the centering of the ribbed plate (3) by moving it slightly from side to side.
4. Screw in the screws (1) with spacers (2) and tighten first only slightly diagonally, then tight.
i Perform a leak test in order to ensure the required gastightness of the pump head after maintenance.

9. Troubleshooting

- Disconnect the pump power supply before working on the pump.
- Make sure the pump is de-energized and secure.
- Check the pump (see Tab. 31 and 32).

Pump does not work	
Cause	Fault remedy
Pump not connected to the mains.	→ Connect pump to the mains.
No voltage in the mains.	→ Check room fuse and switch on if necessary.
For N 838 A_ .12.29 DC-B: <ul style="list-style-type: none"> ▪ The motor board's overcurrent protection circuit has activated. ▪ Maximum temperature of motor board is exceeded ▪ Maximum blocking time of the rotor is exceeded 	<ul style="list-style-type: none"> → Separate pump from the mains. → Allow pump to cool. → Determine and remove the cause of the overcurrent (for example: improper pressure, liquid in the pump heads). <p>i The pump must be separated from the mains for several seconds before the electronics will permit restarting.</p>
Wrong polarity of the connection wires	<ul style="list-style-type: none"> → Separate pump from the mains. → Be aware of right polarity of the connection wires and connect pump.
Connections or hoses are blocked.	<ul style="list-style-type: none"> → Check hoses and connections. → Remove blockage.
External valve is closed or filter is clogged.	→ Check external valves and filters.
Condensate has collected in the pump head.	<ul style="list-style-type: none"> → Detach the condensate source from the pump. → Flush the pump (see Chapter 8.2.1). → Install the pump at the highest point in the system.
Working diaphragm or valve plates/sealings are worn	→ Replace working diaphragm, safety diaphragm and valve plates/sealings (see Section 8.3).

Tab. 31

Flow rate, pressure or vacuum too low	
The pump does not achieve the output specified in the Technical data or the data sheet.	
Cause	Fault remedy
Condensate has collected in the pump head.	<ul style="list-style-type: none"> → Detach the condensate source from the pump. → Flush the pump (see Chapter 8.2.1). → Install the pump at the highest point in the system.
There is gauge pressure on pressure side and at the same time vacuum or a pressure above atmospheric pressure on suction side.	→ Change the pressure conditions.
Pneumatic lines or connection parts have an insufficient cross section.	<ul style="list-style-type: none"> → Disconnect pump from system to determine output values. → Eliminate throttling (e.g. valve) if necessary. → Use lines or connection parts with larger cross section if necessary.

Flow rate, pressure or vacuum too low	
The pump does not achieve the output specified in the Technical data or the data sheet.	
Cause	Fault remedy
Leaks occur on connections, lines or pump head.	➔ Eliminate leaks.
Connections or lines completely or partially jammed.	➔ Check connections and lines. ➔ Remove the jamming parts and particles.
Head parts are soiled.	➔ Clean head components.
Working diaphragm or valve plates/sealings are worn.	➔ Replace working diaphragm, safety diaphragm and valve plates/sealings (see Section 8.3).

Tab. 32

Fault visualization on motor controller (N 838 A_12.29 DC-B only)

The excess of the overcurrent limit, the excess of the maximum temperature of the motor board or the blocking of the rotor is shown as a fault. A red LED on the BLDC motor controller signals the cause of the fault.

Optional setting:

If desired, the motor controller can be programmed so that the error output voltage exhibits the same characteristics as the LED. With factory settings, only 1 or 0 are logically outputted as voltage at the fault output.

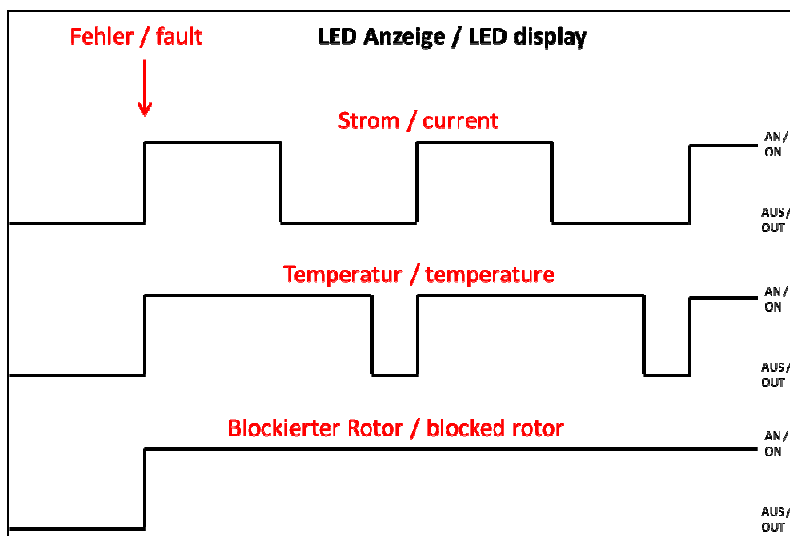

Fig. 19: LED blinking duration according to different faults

To delete the error condition the motor has to be disconnected from the mains.

Fault cannot be rectified

If you are unable to determine any of the specified causes, send the pump to KNF Customer Service (see last page for the address).

1. Flush the pump under atmospheric conditions some minutes with air (if necessary for safety reasons: with an inert gas) to free the pump head of dangerous or aggressive gases (see chapter 8.2.1).
2. Remove the pump.
3. Clean the pump (see chapter 8.2.2).
4. Send the pump, together with completed Health and Safety Clearance and Decontamination Form (Chapter 12), to KNF stating the nature of the transferred medium.

10. Spare parts and accessories

Spare Parts

N 86 AN.12.29 DC-B

Spare part	Position*	Order No.
Valve plate/sealing NBR	(3)	111632
Working diaphragm NBR	(5)	111634
Safety diaphragm NBR	(7)	111637

Tab. 33

*according to Fig. 11

N 86 AP.12.29 DC-B

Spare part	Position*	Order No.
Valve plate/sealing EPDM	(3)	112296
Working diaphragm EPDM	(5)	026968
Safety diaphragm EPDM	(7)	114152

Tab. 34

* according to Fig. 11

N 816 AV.12.29 DC-B

Spare part	Position*	Order No.
Valve plates FPM	(3)	120014
O-ring FPM	(4)	120014
Working diaphragm FPM	(7)	118273
Safety diaphragm FPM	(9)	114284

Tab. 35

* according to Fig. 12

N 838 AN.12.29 DC-B

Spare part	Position*	Order No.
Valve plate/sealing NBR	(4)	112337
Working diaphragm NBR	(7)	112339
Safety diaphragm NBR	(9)	112341

Tab. 36

* according to Fig. 13

N 838 AP.12.29 DC-B

Spare part	Position*	Order No.
Valve plate/sealing EPDM	(4)	112577
Working diaphragm EPDM	(7)	027473
Safety diaphragm EPDM	(9)	112578

Tab. 37

* according to Fig. 13

Accessories

Accessory	Order No.
Wrench for safety diaphragm:	
- N 86 A_.12.29 DC-B	115885
- N 816 AV.12.29 DC-B	115885
- N 838 A_.12.29 DC-B	115886

Tab. 38

Accessories for N 838 A_.12.29 DC-B

Accessory	Order No.
PWM analog voltage converter 1.2V Function: Smoothing of the speed output signal into an analog voltage output and simultaneous transformation of 5V to 1.2V (optional 2.4V)	129011
External potentiometer Function: Setting of the speed via external potentiometer	300292
RS232-TTL-Translator Function: RS232- Level-Translator for customer specific plug versions	123779
Level-Translator RS232 Function: RS232 Level-Translator with SUB-D9 plug	128401
Level-Translator USB Function: RS232 Level-Translator with Micro-USB plug	128402

Tab. 39

11. Returns

Pumps and systems used in laboratories and process-based industries are exposed to a wide variety of conditions. This means that the components contacting pumped media could become contaminated by toxic, radioactive, or otherwise hazardous substances.

For this reason, customers who send any pumps or systems back to KNF must submit a Health and safety clearance and decontamination form in order to avoid a hazardous situation for KNF employees. This Health and safety clearance and decontamination form provides the following information, among other things:

- physiological safety
- whether medium-contacting parts have been cleaned
- whether the equipment has been decontaminated
- media that have been pumped or used

and must declare physiological safety. To ensure worker safety, work may not be started on pumps or systems without a signed Health and safety clearance and decontamination form.

For optimal processing of a return, a copy of this declaration should be sent in advance via e-mail, regular mail, or fax to KNF Customer Service (refer to final page for address). In order to avoid endangering employees who open the shipment's packaging, despite any residual hazards, the original version of the Health and safety clearance and decontamination form must accompany the delivery receipt on the outside of the packing.

The template for the Health and safety clearance and decontamination form is included with these operating instructions and may also be downloaded from the KNF website.

The customer must specify the device type(s) and serial number(s) in the Health and safety clearance and decontamination form in order to provide for the unambiguous assignment of the Declaration to the device that is sent to KNF.

In addition to the customer's declaration of physiological safety, information about operating conditions and the customer's application are also of importance to ensure that the return shipment is handled appropriately. Therefore, the Health and safety clearance and decontamination form requests this information as well.

12. Health and safety clearance and decontamination form



Form: Rev. 00 / download: www.knf.com

Health and safety clearance and decontamination form

This declaration must be present and complete (the original must accompany the shipment's delivery receipt) before the returned device can be examined.

Device type:

Serial number(s):

.....

.....

Reason for returning the device (please describe in detail):

(The device(s) was(were) in operation yes no)

.....

.....

.....

.....

.....

We confirm that the above device(s)

has(have) pumped exclusively **physiologically unobjectionable** media and that it(they) are free of hazardous materials and any materials that are harmful to health.

The device(s) was(were) cleaned yes no

has(have) pumped media of the following category(categories) which are not physiologically unobjectionable and that cleaning of the device(s) (potentially only media-contacting parts) is required.

Name, chemical formula, Material Safety Data Sheet

aggressive

biological

radioactive

toxic

other

The device(s) was(were) decontaminated and work can proceed without special measures yes

Method / proof:

.....

The device(s) was(were) not decontaminated and special measures are required before starting work yes

Measures:

.....

Legally binding declaration

We herewith affirm that the information provided in this form is correct and complete. Shipment of the devices and components is in compliance with statutory regulations.

.....
Company (stamp) Date Name Authorized signature Position

KNF worldwide

Benelux

Netherlands
KNF Verder B.V.
Utrechtseweg 4a
NL-3451 GG Vleuten
Tel. 0031 (0)30 677 92 40
Fax 0031 (0)30 677 92 47
E-mail: info@knf-verder.nl
www.knf-verder.nl

Benelux

Belgium, Luxembourg
KNF Verder N.V.
Kontichsesteenweg 17
B-2630 Aartselaar
Tel. 0032 (0)3 8719624
Fax 0032 (0)3 8719628
E-mail: info@knf.be
www.knf.be

China

KNF Neuberger Trading
(Shanghai) Co., Ltd
No. 36 Lane 1000
Zhang Heng Road
Shanghai 201203, P.R. China
Tel. 0086 (0)21 685 965 66
Fax 0086 (0)21 339 006 26
E-mail: info@knf.com.cn
www.knf.com.cn

Germany

KNF Neuberger GmbH
Alter Weg 3
D-79112 Freiburg
Tel. 0049 (0)7664 5909-0
Fax 0049 (0)7664 5909-99
E-mail: info@knf.de
www.knf.de

France, Morocco, Algeria

KNF Neuberger SAS
4, Bld. d'Alsace Z.I.
F-68128 Village-Neuf
Tel. 0033 (0)389 70 35 00
Fax 0033 (0)389 69 92 52
E-mail: info@knf.fr
www.knf.fr

Great Britain

KNF Neuberger U.K. Ltd.
Avenue 2
Station Lane
Industrial Estate
Witney Oxon OX28 4FA
Tel. 0044 (0)1993 77 83 73
Fax 0044 (0)1993 77 51 48
E-mail: info@knf.co.uk
www.knf.co.uk

India

KNF Pumps + Systems
(India) Pvt. Ltd.
RAJIV GANDHI INFOTECH PARK
Phase 1
Ganga Estate, Survey No. 152/2/2
Above AXIS BANK
Hinjewadi
Pune 411 057
Tel. 0091 (0)20 640 13 923
0091 (0)20 640 08 923
Fax 0091 (0)20 229 33 923
E-mail: info@knfpumps.in
www.knfpumps.in

Italy

KNF ITALIA S.r.l.
Via Flumendosa, 10
I-20132 Milano
Tel. 0039 02 27 20 38 60
Fax 0039 02 27 20 38 48
E-mail: info@knf.it
www.knf.it

Japan

KNF Japan Co.Ltd.
Across Shinkawa Bldg. Annex 3F
1-16-14 Shinkawa, Chuo-ku,
Tokyo, Japan 104-0033
Tel. 0081 (0)3 3551-7931
Fax 0081 (0)3 3551-7932
E-mail: info@knf.co.jp
www.knf.co.jp

Korea

KNF Neuberger Ltd.
Woosan Bldg.RM#202,
336-4, Hwikyung-Dong
Dongdaemun-Ku.,
130-090, Seoul
Tel. 0082 (0)2 959-0255/6
Fax 0082 (0)2 959-0254
E-mail: knf@knfkorea.com
www.knfkorea.com

Sweden, Denmark, Finland, Norway

KNF Neuberger AB
Mejerivägen 4,
P.O. Box 44060
SE-10073 Stockholm
Tel. 0046 (0) 87445113
Fax 0046 (0) 87445117
E-mail: info@knf.se
www.knf.se

Switzerland

Sales
KNF Neuberger AG
Stockenstrasse 6
CH-8362 Balterswil
Tel. 0041 (0)71 973 993 0
Fax 0041 (0)71 973 993 1
E-mail: knf@knf.ch
www.knf.ch

Taiwan

KNF Neuberger Ltd.
9-2 FL., No., 24, Lane 123,
Section 6,
Ming Chuan East Road
Taipei City, Taiwan
Tel. 00886-2-2794-1011
Fax 00886-2-8792-1648
E-mail: knftwn@knftwn.com.tw
www.knftwn.com.tw

USA, Canada, South America

KNF Neuberger, Inc.
Two Black Forest Road
Trenton, New Jersey
08691-1810
Tel. 001 (609) 890-8600
Fax 001 (609) 890-8323
E-mail: knfusa@knf.com
www.knfusa.com
South America
Direct Phone: 001 609-649-1010
E-mail: gb@knf.com

KNF product centres

Product centre for gas pumps:

Germany
KNF Neuberger GmbH
Alter Weg 3
D-79112 Freiburg
Phone 0049(0)7664 5909-0
Fax 0049(0)7664 5909-99
E-mail: info@knf.de
www.knf.de

Product centre for fluid pumps:

Switzerland
KNF FLODOS AG
Wassermatte 2
CH-6210 Sursee
Phone 0041(0)41 925 00 25
Fax 0041(0)41 925 00 35
E-mail: info@knf-flodos.ch
www.knf-flodos.ch

Product centre for micro pumps:

Switzerland
KNF Micro AG
Zelglimatte 1b
CH-6260 Reiden
Tel. 0041(0)62 787 88 88
Fax 0041(0)62 787 88 99
E-mail: info@knf-micro.ch
www.knf-micro.ch