

Rinnai®

Tankless Water Heater

Operation and Installation Manual

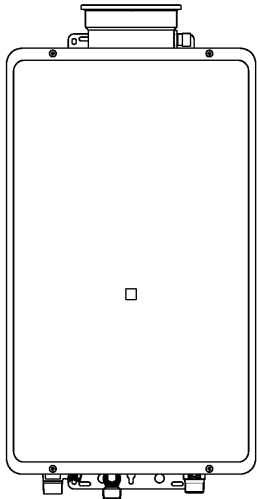

RV53i

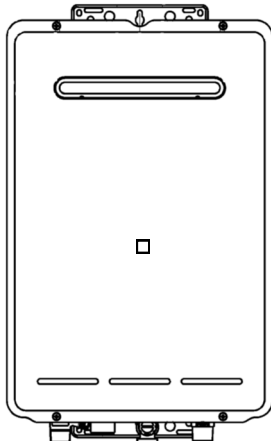

RV53e

RV53iREU-VB2020FFU-US
RV53eREU-VAM1620W-US

Certified for installation in manufactured (mobile) homes.

Table of Contents.....	2
Consumer Safety Information	4
Operating Instructions.....	5
Maintenance	9
Error Codes.....	10
Installation Instructions.....	14
Consumer Support.....	39
French Version.....	42

Register your product at www.rinnairegistration.com or call 1-866-RINNAI1 (746-6241)



RV53i only



ANS Z21.10.3

CSA 4.3

INSTALLER: Leave this manual with the appliance.
CONSUMER: Retain this manual for future reference.

WARNING If the information in these instructions is not followed exactly, a fire or explosion may result causing property damage, personal injury or death.

- Do not store or use gasoline or other flammable vapors and liquids in the vicinity of this or any other appliance.
- **WHAT TO DO IF YOU SMELL GAS**
 - Do not try to light any appliance.
 - Do not touch any electrical switch; do not use any phone in your building.
 - Immediately call your gas supplier from a neighbor's phone. Follow the gas supplier's instructions.
 - If you cannot reach your gas supplier, call the fire department.
- Installation and service must be performed by a qualified installer, service agency or the gas supplier.

California Proposition 65 lists chemical substances known to the state to cause cancer, birth defects, death, serious illness or other reproductive harm. This product may contain such substances, be their origin from fuel combustion (gas, oil) or components of the product itself.

Table of Contents

Specifications	3	<i>Freeze Protection Methods</i>	20
Consumer Safety Information		Manual draining of the water heater	20
<i>Safety Definitions</i>	4	Running a low volume of water through	
<i>Safety Behaviors and Practices</i>	4	the water heater to prevent freezing	20
<i>Safety Features</i>	4	When the water heater or external	
Description of Operation	4	piping has frozen	20
Operating Instructions		<i>Freeze Protection Piping</i>	21
<i>How to Set the Temperature</i>	5	<i>Error Indication or Air Handler</i>	
<i>Setting the Sound Volume (Voice Prompt)</i>	5	<i>Control Switch (RV53i)</i>	22
<i>Temperature Controller Settings</i>	6	<i>Recommended Piping for Basic Installation</i> ..	22
<i>Temperature Options Without</i>		<i>Recommended Piping for</i>	
<i>a Temperature Controller</i>	6	<i>Circulation Systems</i>	23
<i>Using the Water Smart / Bath Fill Function</i>	7	<i>Venting Instructions (RV53i)</i>	
Overview	7	Intake / Exhaust Guidelines	24
Setting the Water Volume	7	Condensate	24
Filling the Tub	8	Maximum Vent Length	25
<i>Setting Controller to Mute</i>	8	Vent Products	25
<i>Setting the Clock</i>	8	<i>Flue Installation - Concentric Venting (RV53i)</i> 26	
<i>Maintenance</i>		<i>Flue Terminal Clearances</i>	
Cleaning	9	(<i>ANS Z21.10.3, CSA 4.3</i>)	27
Vent System (RV53i)	9	<i>Additional Clearances</i>	28
Air Intake and Exhaust (RV53e)	9	<i>Connecting Multiple Water Heaters</i>	29
Motors	9	Guidelines	29
Temperature Controller	9	<i>High Altitude Installations</i>	29, 30
Lime / Scale Build-up	9	<i>Temperature Controller Installation</i>	
Snow Accumulation	9	Location	31
Visual Inspection of Flame	9	Configurations	31
Error Codes		Cable Lengths and Size	31
<i>Front Panel Display Indication</i>	10	Mounting the Controller (RV53i)	32
<i>Error Code Table</i>	10,11	Mounting the Controller (RV53e)	33
<i>Trouble Shooting for Common Issues</i>	12	<i>Operating Instructions</i>	34
<i>Accessing Operating Information</i>	12	Technical Data	
<i>Water Quality</i>	12	<i>Pressure Drop Curve</i>	35
<i>Flushing the Heat Exchanger</i>		<i>Outlet Flow Data</i>	35
(<i>Error Code: LC or 00</i>)	13	<i>Space Heating</i>	36
Installation Instructions	14	<i>Dimensions</i>	37
<i>General Instructions</i>	14	<i>Ladder Diagrams</i>	38
<i>Environment</i>	15	Consumer Support	
<i>Clearances from Appliance</i>	15	<i>Warranty Information</i>	39
<i>Attachment of the Water Heater</i>	15	<i>Limited Warranty</i>	39, 40
<i>Electrical Connection</i>	16	State Regulations	41
<i>Gas Piping</i>	16	French Version	42-59
General Instructions	16		
Pipe Sizing Procedure - Example	17		
<i>Water Piping</i>			
Isolation Valves and			
Pressure Relief Valves	18		
General Instructions	19		
Pressure Relief Valve	19		
Freeze Protection	19		

Specifications

Model		<i>RV53i</i>	<i>RV53e</i>
Minimum Gas Consumption Btu/h		15,000	20,200 (LP) 19,000 (NG)
Maximum Gas Consumption Btu/h		150,000	120,000
Hot water capacity (Min - Max) *		0.6 - 5.3 GPM (2.4 - 20.0 L/min)	
Hot water capacity (45°F rise)		5.3 GPM (20.0 L/min)	4.2 GPM (16.0 L/min)
Temperature Settings (without temperature controller)		120° F (49° C), default or 140° F (60° C)	
Temperature Controller Default Setting		104° F (40° C)	
Maximum Temp Setting (residential) see Temperature Ranges for more information		140° F (60° C)	
Minimum Temperature Setting		98° F (37° C)	
Weight		51 lb (23.0 kg)	34.2 lb (15.5 kg)
Energy Factor		0.82	0.82
Noise level		49 dB	
Electrical Consumption	Normal	55 W	33 W
	Standby	2 W	
	Anti-frost Protection	184 W	74W
By-Pass Control		Fixed	
Minimum Gas Supply Pressure	Natural Gas	5.0 inch W.C.	
	Propane	8.0 inch W.C.	
Maximum Gas Supply Pressure	Natural Gas	10.5 inch W.C.	
	Propane	13.5 inch W.C.	
Type of Appliance		Temperature controlled continuous flow gas hot water system.	
Operation		With or without temperature controller, mounted in kitchen, bathroom, etc.	
Approved Gas Type		Natural Gas or Propane - Ensure unit matches gas type supplied at the installation location.	
Connections		Gas Supply: 3/4" MNPT, Cold Water Inlet: 3/4" MNPT, Hot Water Outlet: 3/4" MNPT	
Ignition System		Direct Electronic Ignition	
Electric Connections		Appliance: AC 120 Volts, 60Hz. Remote Control: DC 12 Volts (Digital)	
Water Temperature Control		Simulation Feedforward and Feedback.	
Water Supply Pressure		Minimum Water Pressure: 20 PSI (Recommended 30-80 PSI for maximum performance)	
Maximum Water Supply Pressure		150 PSI	
Remote Control Cable		Non-Polarized Two Core Cable (Minimum 22 AWG)	
Energy Star Qualified		Yes	
Certified for installation in manufactured (mobile) homes		Yes	

* Minimum flow may vary slightly depending on the temperature setting and the inlet water temperature.

Rinnai is continually updating and improving products. Therefore, specifications are subject to change without prior notice.

The maximum inlet gas pressure must not exceed the value specified by the manufacturer. The minimum value listed is for the purpose of input adjustment.

Consumer Safety Information

Safety Definitions



This is the safety alert symbol. This symbol alerts you to potential hazards that can kill or hurt you and others.

! DANGER

Indicates an imminently hazardous situation which, if not avoided, will result in death or serious injury.

! WARNING

Indicates a potentially hazardous situation which, if not avoided, could result in death or serious injury.

! CAUTION

Indicates a potentially hazardous situation which, if not avoided, could result in minor or moderate injury. It may also be used to alert against unsafe practices.

Safety Behaviors and Practices

! WARNING

- Keep the area around the appliance clear and free from combustible materials, gasoline, and other flammable vapors and liquids.
- Any alteration to the appliance or its controls can be dangerous and will void the warranty.
- Always check the water temperature before entering a shower or bath.
- Do not use this appliance if any part has been under water. Immediately call a qualified service technician to inspect the appliance and to replace any part of the control system and any gas control which has been under water.

Safety Features

- **Overheat:** The appliance will automatically shut down when the appliance exceeds a predetermined temperature.
- **Flame Failure:** The appliance will automatically shut down if the burner flame is extinguished.
- **Power Failure:** The appliance will cut off the gas if it loses electrical power.
- **Power Surge Fuse:** A glass fuse protects against overcurrent. If the fuse blows then all indicator lamps will be off.
- **Fusible Link:** In case the overheat feature does not prevent the temperature from rising then the fusible link will break shutting off the appliance.

Description of Operation

The Rinnai water heater is one of the most advanced water heaters available. It provides a continuous supply of hot water at a preset temperature. This appliance is direct vent where air is brought in from the outside and combustion gases are exhausted to the outside.

While electricity, water, and gas supplies are connected, the Rinnai water heater produces hot water whenever a hot water tap is open.

Ignition is electronic. There is no pilot light consuming gas while the water heater is not being used. The gas burner lights automatically when the hot water tap is opened and goes out when the tap is closed.

Installation of the temperature controller is highly recommended. The temperature controller can set the temperature within a specific range and can provide error codes to diagnose any problems.



The temperature of the outgoing hot water is constantly monitored. The Rinnai water heater may adjust the water flow in order to maintain the temperature setting. The water flow may vary from summer to winter due to the difference in ground water temperature.

Operating Instructions

The RV53i and RV53e models do not come with a temperature controller. There are several models of temperature controllers that can be purchased separately.

A maintenance display or status monitor is provided in the front panel to indicate operating status and error codes.

How to Set the Temperature

 DANGER	Hot water can be dangerous, especially for infants or children, the elderly, or infirm. There is hot water scald potential if the thermostat is set too high.
	Water temperatures over 125° F (52° C) can cause severe burns or scalding resulting in death.
	Hot water can cause first degree burns with exposure for as little as:
	3 seconds at 140° F (60° C)
	20 seconds at 130° F (54° C)
	8 minutes at 120° F (49° C)
	Test the temperature of the water before placing a child in the bath or shower.
	Do not leave a child or an infirm person in the bath unsupervised.

1. If the water heater is off, press the ON/OFF button to turn on.
2. Press the “Priority button” on the temperature controller. The green Priority light will glow indicating that this controller is controlling the temperature and that the Rinnai water heater is ready to supply hot water.



The priority can only be changed while no hot water is running.

3. Press the ▲ or ▼ buttons to obtain the desired temperature setting.
- All hot water sources are able to provide water at this temperature setting until it is changed again at this or another temperature controller.



Hot water temp.



NOTICE	While any hot water is being provided, the temperature setting can only be adjusted between 98° F (37° C) and 110° F (43° C).
---------------	---

NOTICE	Check local codes for the maximum water temperature setting allowed when used in nursing homes, schools, day care centers, and all other public applications.
---------------	---

NOTICE	If a newly installed unit with a controller has not been powered for at least 6 hours then the temperature will return to the default setting of 104° F (40° C) if power is interrupted.
---------------	--

NOTICE	There may be a variation between the temperature displayed on the temperature controller and the temperature at the tap due to weather conditions or the length of pipe to the water heater.
---------------	--

Temperature Controller Settings

This water heater will attempt to provide hot water at the temperature setting even when the water flow is varied or when more than 1 tap is in use. The water heater can deliver water at only one temperature setting at a time. The available temperatures for a given model are provided below.

Model	Temperature Settings Available (°F)														
RV53i RV53e	98	100	102	104	106	108	110	115	120	125	130	135	140	150*	160*
Temp in Celsius °C	37	38	39	40	41	42	43	46	49	52	54	57	60	66	71

* MCC-91 Temperature Controller

These settings require the MCC-91 controller. When the MCC-91 controller is connected, these higher temperatures are available on all controller models in the system.

Use of an MCC-91 controller in a residential dwelling will reduce the warranty coverage to that of a commercial warranty application which is no coverage for these models (except when an MCC-91 is used with a Rinnai Hydronic Air Handler). See the Warranty Information for more information on the warranty.

The MCC-91 controller is intended for commercial and hydronic applications only. If an MCC-91 controller is used in a residential dwelling for a hydronics application, a mixing valve must also be installed to limit the potable hot water temperature to a safe temperature. Water temperatures over 125° F (52° C) can cause severe burns or scalding. Refer to the Danger Alert on water temperatures. Rinnai shall not, in any event, be liable for damages resulting from such misuse or misapplication.

Suggested temperatures are

- Kitchen 120 °F (49° C)
- Shower 98 - 110 °F (37 - 43 °C)
- Bath Fill 102 - 110 °F (39 - 43 °C)

These temperatures are suggestions only.

A temperature lower than 98 °F (37 °C) can be obtained at the tap by mixing with cold water.

To change the temperature scale from Celsius to Fahrenheit or vice versa, press and hold the "On/Off" button for 5 seconds while the water heater is OFF.

Temperature Options Without a Temperature Controller

The default temperature setting for this appliance installed without a temperature controller is 120° F (49° C). If desired the temperature setting can be changed to 140° F (60° C) by adjustment of a switch.

Set switch 5 to ON to obtain 140° F water temperature setting.

Set switch 5 to OFF (default) to obtain 120° F water temperature setting.

If a temperature controller is installed then switch 5 has no effect on temperature settings.

⚠ WARNING DO NOT adjust the other switches unless specifically instructed to do so.

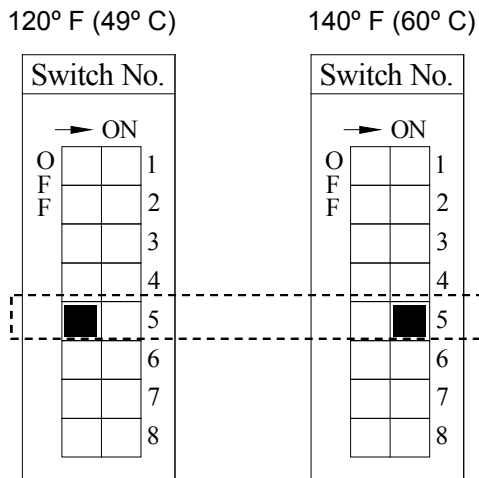

Using the Water Smart / Bath Fill Function

Overview

This function is exclusive to the BC-100V temperature controller. The bath fill function allows the consumer to fill a tub with a preset volume of water at a preset temperature. This is done by pressing the bath fill button on the BC-100V controller while no hot water is flowing and then opening only the hot water tap. The water heater will stop the hot water flow when the preset volume has been reached. The hot water tap should then be closed and the bath fill button pressed.

The temperature settings for the bath fill function are limited to those in the table below.

Bath Fill Temperature Settings Available						
°F	98	100	102	104	106	108
°C	37	38	39	40	41	42
°F	110	112	114	116	118	120
°C	43	44	46	47	48	49

NOTICE

Multiple Water Heaters

The bath fill function will not work properly if it is connected to multiple water heaters. The tub will overflow because the bath fill function is not able to measure the water volume when connected to multiple water heaters.

NOTICE

Power Loss

If power is lost during the bath fill function, the water heater will shut down but the water will continue to flow. When power returns, the water shuts off and Error Code 03 appears on the controller.

If power is lost after the bath has filled but before the bath fill function button is de-selected, then the water will not flow during the power loss or after the power is returned. Once power returns, close the hot water tap and de-select the bath fill function. No error code appears.

NOTICE

Anti-scald Fixtures

Do not use with single handle fixtures that have anti-scald features built into them. These fixtures allow a predetermined amount of cold water which is not taken into account by the bath fill function.

Setting the Water Volume

The default volume is set to 25 gallons. The volume can be set between 10 and 120 gallons.



1. Press the "Priority" button on the temperature controller. The green Priority light will glow indicating that this controller is controlling the temperature and that the Rinnai water heater is ready to supply hot water.

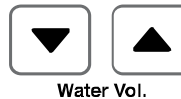

4. Press the "Water Vol." ▲ or ▼ buttons to obtain the desired water volume in gallons.



2. Press the "Water Smart Bath Fill" button to set the water volume and temperature.



5. Press the "Water Smart Bath Fill" button.

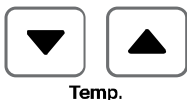

3. Press the "Temp" ▲ or ▼ buttons to obtain the desired temperature setting.

NOTICE

To Prevent Over Filling

Be careful not to overflow the bath. An average bath volume is 60 gallons. When filling the bath using this function for the first time:

- Monitor and remain by the bath while the water is running.
- Use a low bath fill volume less than 25 gallons.

Using the Water Smart / Bath Fill Function

Filling the Tub



1. Press the “Water Smart / Bath Fill” button once. The button will illuminate, and a tone will sound.
2. The voice prompt will announce “The hot water system is ready. Open the hot water tap.” Open the hot water tap. Make sure the water volume is set. Refer to “Setting the Water Volume” on the previous page. Open the hot water tap. The “In Use” indicator will illuminate on MC-100V and BC-100V controllers. The hot water will begin to flow.

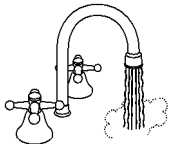

3. When the preset volume of water has been produced then
 - the water flow will cease
 - the “Water Smart / Bath Fill” button will flash
 - a tone will sound
 - the voice prompt will announce, “Bath fill is complete. Turn off the bath hot water tap and push the Bath Fill button.”



4. Turn off the bath hot water tap and push the Bath Fill button. The water heater will not allow hot water to flow from any source until the “Water Smart / Bath Fill” button is pushed. The button light will go out.

NOTICE

To Stop the Bath Fill Before it Finishes

To stop the water flow during the Bath Fill function, press the “Water Smart / Bath Fill” button. The button will flash and the voice prompt will announce, “Hot water is not available. Turn off all hot water taps and push the Bath Fill button.” Follow the voice prompt instructions.

NOTICE

When Other Taps Are Open

During the bath fill function, any hot water flowing at other locations, subtracts from the total amount of water for the bath. For example if the bath fill function is set for 50 gallons and 5 gallons of hot water are used at other locations during the fill period then the bath will only fill with 45 gallons.

NOTICE

During the operation of the bath fill function, the MC-91 “In Use” indicator does not light up.

Setting Controller to Mute

Models MC-91 and MCC-91

To eliminate the beeps when keys are pressed or to turn the beeps back on, press and hold both the ▲ and ▼ buttons until a beep is heard (approximately 5 seconds).

Setting the Clock



- MC-100V** Press the “Function” button twice within 10 seconds to set the clock. Press the ▲ or ▼ button to reach the desired time. The clock on the BC-100V automatically shows the time which has been set on the MC-100V.

WARNING

Turn off the electrical power supply, the manual gas valve and the manual water control valve whenever servicing the unit.

Repairs and maintenance should be performed by a qualified service technician. The appliance should be inspected annually by a qualified service technician. Verify proper operation after servicing.

Cleaning

It is imperative that control compartments, burners, and circulating air passageways of the appliance be kept clean.

Clean as follows:

1. Turn off and disconnect electrical power. Allow to cool.
2. Close the water shut off valves. Remove and clean the water inlet filter.
3. Remove the front panel by removing 4 screws.
4. Use pressurized air to remove dust from the main burner, heat exchanger, and fan blades. Do not use a wet cloth or spray cleaners on the burner. Do not use volatile substances such as benzene and thinners. They may ignite or fade the paint.
5. Use soft dry cloth to wipe cabinet.

Vent System (RV53i)

The vent system should be inspected at least annually for blockages or damage.

Air Intake and Exhaust (RV53e)

The air intake and exhaust should be inspected at least annually for blockages or damage.

Motors

Motors are permanently lubricated and do not need periodic lubrication. Keep fan and motor free of dust and dirt by cleaning annually.

Temperature Controller

Use a soft damp cloth to clean the temperature controller. Do not use solvents.

Lime / Scale Build-up

If you receive Error Code "LC", refer to the procedure, *Flushing the Heat Exchanger*. Refer to the section on *Water Quality* to see if your water needs to be treated or conditioned. (When checking maintenance code history, "00" is substituted for "LC".)

Snow Accumulation

Keep the area around flue terminal free of snow and ice. The appliance will not function properly if the intake air or exhaust is impeded (blocked or partially blocked) by obstructions.

Visual Inspection of Flame

The burner must flame evenly over the entire surface when operating correctly. The flame must burn with a clear, blue, stable flame. See the parts breakdown of the burner for the location of the view ports.

The flame pattern should be as shown in the figures below.

SATISFACTORY

FRONT VIEW

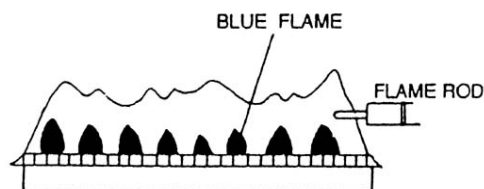

UNSATISFACTORY

FRONT VIEW

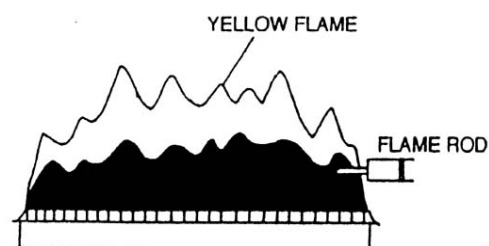

Error Codes

The Rinnai water heater has the ability to check its own operation continuously. If a fault occurs, an error code will flash on the display in the front panel and on the temperature controller if installed. This assists with diagnosing the fault and may enable you to overcome a problem without a service call. Please identify the code displayed when inquiring about service.

Front Panel Display Indications

--	Standby (power is supplied but there is no demand for hot water).
On	Hot water is being supplied.
FL or FH	Stands for Forced Low and Forced High combustion. Only seen during the gas pressure setting procedure which is done when certain components are replaced.
Error code flashing	The error code will stop flashing after the problem is corrected and the water heater supplies hot water.

Error Code Table

⚠ WARNING Some of the checks below may need to be done by a qualified service technician. Call a service technician for any remedy that involves gas or electricity. Call a service technician if you have any doubt or reservation about performing the remedy yourself.

Code	Fault	Remedy		
02	No burner operation during freeze protection mode	Service Call		
03	Power interruption during Bath Fill (Water will not flow when power returns).	Turn off all hot water taps. Press ON/OFF twice.		
10	Air Supply or Exhaust Blockage	(RV53i only) Ensure Rinnai approved venting materials are being used. (RV53i only) Check all vent components for proper connections. (RV53i only) Ensure vent length is within limits. (RV53i only) Ensure condensation collar was installed correctly. Check that nothing is blocking the inlet or exhaust. Verify dip switches are set properly. Check fan for blockage.		
11	No Ignition	Check that the gas is turned on at the water heater, gas meter, or cylinder. Ensure gas type and pressure is correct. Ensure gas line, meter, and/or regulator is sized properly. Bleed all air from gas lines. Verify dip switches are set properly. Ensure appliance is properly grounded. Disconnect EZConnect™ or MSA controls to isolate the problem. Ensure igniter is operational. Check igniter wiring harness for damage. Check gas solenoid valves for open or short circuits. Remove burner cover and ensure all burners are properly seated. Remove burner plate and inspect burner surface for condensation or debris.		
12	Flame Failure	<table border="0" style="width: 100%;"> <tr> <td style="vertical-align: top; width: 50%;"> Check that the gas is turned on at the water heater and gas meter. Check for obstructions in the flue outlet. Ensure gas line, meter, and/or regulator is sized properly. Ensure gas type and pressure is correct. Bleed all air from gas lines. Ensure proper Rinnai venting material was installed. Ensure condensation collar was installed properly. Ensure vent length is within limits. Verify dip switches are set properly. Ensure appliance is properly grounded. Disconnect keypad. </td> <td style="vertical-align: top; width: 50%;"> Disconnect EZConnect™ or MSA controls to isolate the problem. Check power supply for loose connections. Check power supply for proper voltage and voltage drops. Ensure flame rod wire is connected. Check flame rod for carbon build-up. Disconnect and reconnect all wiring harnesses on unit and PC board. Check for DC shorts at components. Check gas solenoid valves for open or short circuits. Remove burner plate and inspect burner surface for condensation or debris. Check the ground wire for the PC board. </td> </tr> </table>	Check that the gas is turned on at the water heater and gas meter. Check for obstructions in the flue outlet. Ensure gas line, meter, and/or regulator is sized properly. Ensure gas type and pressure is correct. Bleed all air from gas lines. Ensure proper Rinnai venting material was installed. Ensure condensation collar was installed properly. Ensure vent length is within limits. Verify dip switches are set properly. Ensure appliance is properly grounded. Disconnect keypad.	Disconnect EZConnect™ or MSA controls to isolate the problem. Check power supply for loose connections. Check power supply for proper voltage and voltage drops. Ensure flame rod wire is connected. Check flame rod for carbon build-up. Disconnect and reconnect all wiring harnesses on unit and PC board. Check for DC shorts at components. Check gas solenoid valves for open or short circuits. Remove burner plate and inspect burner surface for condensation or debris. Check the ground wire for the PC board.
Check that the gas is turned on at the water heater and gas meter. Check for obstructions in the flue outlet. Ensure gas line, meter, and/or regulator is sized properly. Ensure gas type and pressure is correct. Bleed all air from gas lines. Ensure proper Rinnai venting material was installed. Ensure condensation collar was installed properly. Ensure vent length is within limits. Verify dip switches are set properly. Ensure appliance is properly grounded. Disconnect keypad.	Disconnect EZConnect™ or MSA controls to isolate the problem. Check power supply for loose connections. Check power supply for proper voltage and voltage drops. Ensure flame rod wire is connected. Check flame rod for carbon build-up. Disconnect and reconnect all wiring harnesses on unit and PC board. Check for DC shorts at components. Check gas solenoid valves for open or short circuits. Remove burner plate and inspect burner surface for condensation or debris. Check the ground wire for the PC board.			

Error Code Table

Code	Fault	Remedy
14	Thermal Fuse	<p>Check gas type of unit and ensure it matches gas type being used.</p> <p>Check for restrictions in air flow around unit and vent terminal.</p> <p>Check for low water flow in a circulating system causing short-cycling.</p> <p>Ensure dip switches are set to the proper position.</p> <p>Check for foreign materials in combustion chamber and/or exhaust piping.</p> <p>Check heat exchanger for cracks and/or separations.</p> <p>Check heat exchanger surface for hot spots which indicate blockage due to scale build-up.</p> <p>Refer to instructions in manual for flushing heat exchanger.</p> <p>Measure resistance of safety circuit.</p> <p>Ensure high fire and low fire manifold pressure is correct.</p> <p>Check for improper conversion of product.</p>
16	Over Temperature Warning	<p>Check for restrictions in air flow around unit and vent terminal.</p> <p>Check for low water flow in a circulating system causing short-cycling.</p> <p>Check for foreign materials in combustion chamber and/or exhaust piping.</p> <p>Check for clogged heat exchanger.</p>
31	Burner Sensor Error	<p>Measure resistance of sensor.</p> <p>Replace sensor.</p>
32	Outgoing Water Temperature Sensor Fault	<p>Check sensor wiring for damage.</p> <p>Measure resistance of sensor.</p> <p>Clean sensor of scale build-up.</p> <p>Replace sensor.</p>
33	Heat Exchanger Outgoing Temperature Sensor Fault	<p>Check sensor wiring for damage.</p> <p>Measure resistance of sensor.</p> <p>Clean sensor of scale build-up.</p> <p>Replace sensor.</p>
34	Combustion Air Temperature Sensor Fault	<p>Check for restrictions in air flow around unit and vent terminal.</p> <p>Check sensor wiring for damage.</p> <p>Measure resistance of sensor.</p> <p>Clean sensor of scale build-up.</p> <p>Ensure fan blade is tight on motor shaft and is in good condition.</p> <p>Replace sensor.</p>
52	Modulating Solenoid Valve Signal Abnormal	<p>Check modulating gas solenoid valve wiring harness for loose or damaged terminals.</p> <p>Measure resistance of valve coil.</p>
61	Combustion Fan Failure	<p>Ensure fan will turn freely.</p> <p>Check wiring harness to motor for damaged and/or loose connections.</p> <p>Measure resistance of motor winding.</p>
65	Water Flow Control Fault	<p>The water flow control valve has failed to close during the bath fill function. Immediately turn off the water and discontinue the bath fill function. Contact a state qualified or licensed contractor to service the appliance.</p>
71	Solenoid Valve Circuit Fault	<p>Replace the PC Board.</p>
72	Flame Sensing Device Fault	<p>Ensure flame rod is touching flame when unit fires.</p> <p>Check all wiring to flame rod for damage.</p> <p>Remove flame rod and check for carbon build-up; clean with sand paper.</p> <p>Check inside burner chamber for any foreign material blocking flame at flame rod.</p> <p>Measure micro amp output of sensor circuit with flame present.</p> <p>Replace flame rod.</p>
73	Burner Sensor Circuit Error	<p>Check sensor wiring and PC board for damage.</p> <p>Replace sensor.</p>
LC	Scale Build-up in Heat Exchanger (when checking maintenance code history, "00" is substituted for "LC")	<p>Flush heat exchanger. Refer to instructions in manual.</p> <p>Replace heat exchanger.</p> <p>NOTE: The LC code is the only error code that will allow the unit to keep running. The display will alternate between the LC code and the temperature setting. The controller will continue to beep. The LC code will reset if power is turned off and then on.</p>
No code	Nothing happens when water flow is activated.	<p>Clean inlet water supply filter.</p> <p>On new installations ensure hot and cold water lines are not reversed.</p> <p>Check for bleed over. Isolate unit from building by turning off cold water line to building.</p> <p>Isolate the circulating system if present. Open your pressure relief valve; if water is flowing, there is bleed over in your plumbing.</p> <p>Ensure you have at least the minimum flow rate required to fire unit.</p> <p>Ensure turbine spins freely.</p> <p>Measure the resistance of the water flow control sensor.</p> <p>Check for DC shorts at components.</p>

Trouble Shooting for Common Issues

I don't have any hot water when I open the tap.

Make sure there is gas, water, and electricity to the Rinnai water heater (power is turned on and the gas is turned on).

When I was using the hot water, the water got cold.

If you adjusted the flow from the tap to lessen it, you may have gone below the minimum flow required. The Rinnai water heater requires a minimum flow rate to operate. (See the specification page for the flow rate of your model.)

If you are experiencing issues with higher temperature settings, then Rinnai recommends reducing the temperature setting. Selecting a temperature closer to that which is actually used at the faucet will increase the amount of hot water being delivered to the faucet, due to less cold water mixing at the fixture.

White smoke comes out of the exhaust.

During colder weather when the exhaust temperature is much hotter than the outside air, the exhaust fumes condense producing water vapor.

When I open a hot tap, I do not immediately get hot water.

Hot water must travel through your plumbing from the Rinnai water heater to the faucet. The time period for hot water to reach your fixture is determined by the amount of water in the plumbing system between the water heater and the fixture, water pressure, and the flow rate of the fixture.

After I turn off the hot water tap, the fan on the Rinnai water heater continues to run.

The fan is designed to continue running for a short time after the flow of water stops. This is to ensure constant water temperatures during rapid starting and stopping, as well as exhausting any residual gas flue products from the unit.

Accessing Operating Information

Models MC-91 and MCC-91

To display the most recent error codes press and hold the "On/Off" button for 2 seconds. While holding the "On/Off" button press the ▲ button. The last 9 error codes will flash one after the other. To exit this mode press the "On/Off" and ▲ button as before.

To display the water flow through the water heater press and hold the ▲ button for 2 seconds and without releasing the ▲ button press the "On/Off" button.

To display the outlet water temperature press and hold the ▼ button for 2 seconds and without releasing the ▼ button press the "On/Off" button.

Water Quality

Consideration of care for your water heater should include evaluation of water quality. If the water quality exceeds the target levels provided in the table, you may want to treat or condition the water.

* Source: Part 143 National Secondary Drinking Water Regulations

	Maximum Level
Total Hardness	Up to 200 mg / L
Aluminum *	Up to 0.2 mg / L
Chlorides *	Up to 250 mg / L
Copper *	Up to 1.0 mg / L
Iron *	Up to 0.3 mg / L
Manganese *	Up to 0.05 mg / L
pH *	6.5 to 8.5
TDS (Total Dissolved Solids) *	Up to 500 mg / L
Zinc *	Up to 5 mg / L

Flushing the Heat Exchanger (Error Code: LC or 00)

An "LC" or "00" error code indicates the unit is beginning to lime up and must be flushed. Failure to flush the appliance will cause damage to the heat exchanger. Damage caused by lime build-up is not covered by the unit's warranty. After flushing, reset the LC fault code by turning off the power to the unit and turning the power back on.

1. Disconnect electrical power to the water heater.
2. Close the shutoff valves on both the hot water and cold water lines (V3 and V4).
3. Connect pump outlet hose (H1) to the cold water line at service valve (V2).
4. Connect drain hose (H3) to service valve (V1).
5. Pour 4 gallons of undiluted virgin, food grade, white vinegar into pail.
6. Place the drain hose (H3) and the hose (H2) to the pump inlet into the cleaning solution.
7. Open both service valves (V1 and V2) on the hot water and cold water lines.
8. Operate the pump and allow the cleaning solution to circulate through the water heater for at least 1 hour at a rate of 4 gallons per minute (15.1 liters per minute).
9. Turn off the pump.
10. Rinse the cleaning solution from the water heater as follows:
 - a. Remove the free end of the drain hose (H3) from the pail. Place in sink or outside to drain.
 - b. Close service valve, (V2), and open shutoff valve, (V4). Do not open shutoff valve, (V3).
 - c. Allow water to flow through the water heater for 5 minutes.
 - d. Close shutoff valve (V4). When unit has finished draining remove the in-line filter at the cold water inlet and clean out any residue. Place filter back into unit and open valve (V4).
 - e. Close service valve, (V1), and open shutoff valve, (V3).
11. Disconnect all hoses.
12. Restore electrical power to the water heater.

CLEAN THERMISTORS

Remove and clean thermistors with a soft cloth or sponge after removing O-rings.

Cleaning solution is 4 gallons of undiluted virgin, food grade, white vinegar.

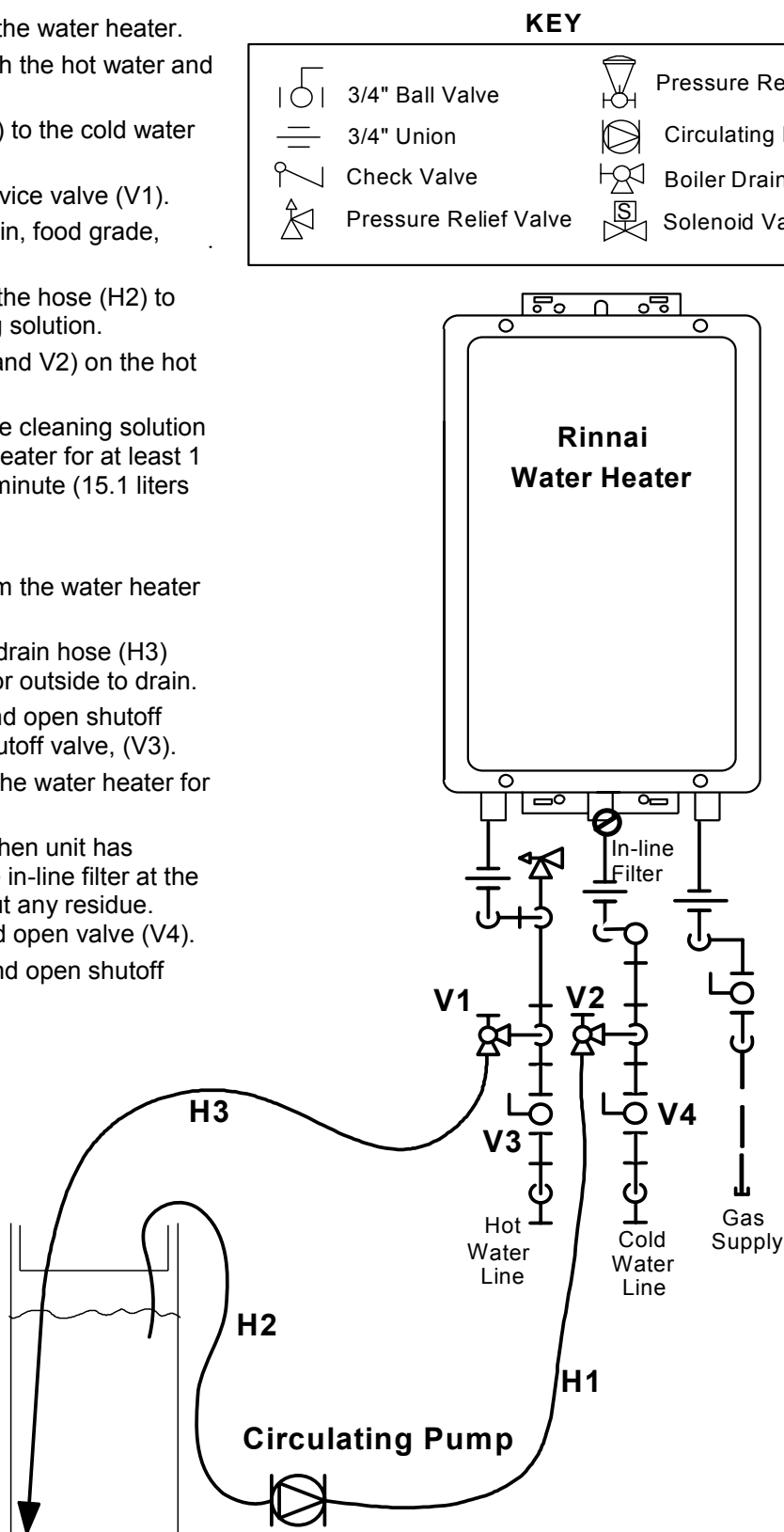

Installation Instructions

Only properly trained and qualified installers should install this appliance. The warranty may be voided due to improper installation or installation by a non-qualified installer.

Rinnai highly recommends all installers attend a product knowledge class.

For information on a Rinnai Training Course or for questions on installation call 1-800-621-9419.

RV53i **REU-VB2020FFU-US**

RV53e **REU-VAM1620W-US**

The RV53i and RV53e are certified for installation in manufactured (mobile) homes.

General Instructions

WARNING

Do not use substitute materials.

Use only parts certified with the appliance.

- This appliance must be installed by a state qualified or licensed contractor. It is the responsibility of the person having the water heater installed to ensure the installing contractor has proper licenses and permits for installing water heaters in your location. Rinnai highly recommends that installers attend a product knowledge class to ensure customer satisfaction and warranty coverage. Failure to comply with state and local codes pertaining to water heater installations may void the warranty.
- The RV53i is not to be installed outdoors.
- The RV53e is not to be installed indoors.
- A qualified installer or service technician should install the appliance, inspect it, and leak test it before use.
- The installation must conform with local codes or, in the absence of local codes, with the *National Fuel Gas Code, ANSI Z223.1/NFPA 54*, or the *Natural Gas and Propane Installation Code, CSA B149.1*. If installed in a manufactured home, the installation must conform with the *Manufactured Home Construction and Safety Standard, Title 24 CFR, Part 3280* and/or *CAN/SCA Z240 MH Series, Mobile Homes*.
- The appliance, when installed, must be electrically grounded in accordance with local codes or, in the absence of local codes, with the *National Electrical Code, ANSI/NFPA 70*, or the *Canadian Electrical Code, CSA C22.1*.
- The appliance and its appliance main gas valve must be disconnected from the gas supply piping system during any pressure testing of that system at test pressures in excess of 1/2 psi (3.5 kPa) (13.84 in W.C.).
- The appliance must be isolated from the gas supply piping system by closing its individual manual shutoff valve during any pressure testing of the gas supply piping system at test pressures equal to or less than 1/2 psi (3.5 kPa) (13.84 in W.C.).
- Follow the installation instructions and those in *Care and Maintenance* for adequate combustion and ventilation air.
- The appliance should be located in an area where water leakage of the unit or connections will not result in damage to the area adjacent to the appliance or to lower floors of the structure. When such locations cannot be avoided, it is recommended that a suitable drain pan, adequately drained, be installed under the appliance. The pan must not restrict combustion air flow.
- The flow of combustion and ventilation air shall not be obstructed. Combustion air shall not be supplied from occupied spaces.
- This appliance is not suitable for use in an application such as a pool or spa heater that uses chemically treated water. (This appliance is suitable for filling large or whirlpool bath tubs with potable water.)
- If a water heater is installed in a closed water supply system, such as one having a backflow preventer in the cold water supply line, means shall be provided to control thermal expansion. Contact the water supplier or local plumbing inspector on how to control thermal expansion.
- Should overheating occur or the gas supply fail to shut off, turn off the manual gas control valve to the appliance.
- Keep the air intake location free of chemicals such as chlorine or bleach that produce fumes. These fumes can damage components and reduce the life of your appliance.
- For gas type conversion, contact Rinnai.

Environment

Air surrounding the water heater, venting, and vent termination (s) is used for combustion and must be free of any compounds that cause corrosion of internal components. These include corrosive compounds that are found in aerosol sprays, detergents, bleaches, cleaning solvents, oil based paints/ varnishes, and refrigerants. The air in beauty shops, dry cleaning stores, photo processing labs, and storage areas for pool supplies often contains these compounds. Therefore Rinnai recommends that outdoor models be used for these locations where possible.

The water heater, venting, and vent termination(s) should not be installed in any areas where the air may contain these corrosive compounds. If it is necessary for a water heater to be located in areas which may contain corrosive compounds, the following instructions are strongly recommended.

IMPORTANT CONSIDERATIONS FOR:

Indoor/Internal Water Heaters

- DO NOT Install in areas where air for combustion can be contaminated with chemicals.

- Before installation, consider where air has the ability to travel within the building to the water heater.
- Where possible, install the water heater in a sealed closet so that it is protected from the potential of contaminated indoor air.
- Chemicals that are corrosive in nature should not be stored or used near the water heater.

Outdoor/External Water Heaters and Vent Terminations of Indoor/Internal Water Heaters

- Install the water heater as far away as possible from exhaust vent hoods.
- Install as far away as possible from air inlet vents. Corrosive fumes may be released through these vents when air is not being brought in through them.
- Chemicals that are corrosive in nature should not be stored or used near the water heater or vent termination.

Damage and repair due to corrosive compounds in the air is not covered by warranty.

Clearances from Appliance

RV53i	to Com-bustibles	to Non-Com-bustibles
Top of Heater	6 inches * (152 mm)	2 inches * (51 mm)
Back of Heater	0 (zero)	0 (zero)
Front of Heater	6 inches (152 mm)	6 inches (152 mm)
Sides of Heater	2 inches (51 mm)	1/2 inch (13 mm)
Ground/Bottom	12 inches (305 mm)	12 inches (305 mm)
Vent	0 (zero)	0 (zero)

RV53e	to Com-bustibles	to Non-Com-bustibles
Top of Heater	12 inches (305 mm)	2 inches (51 mm)
Back of Heater	0 (zero)	0 (zero)
Front (Panel)	24 inches (610 mm)	0 (zero)
Front (Exhaust)	24 inches (610 mm)	24 inches (610 mm)
Sides of Heater	6 inches (152 mm)	1/8 inch (3.2 mm)
Floor/Ground	12 inches (305 mm)	2 inches (51 mm)

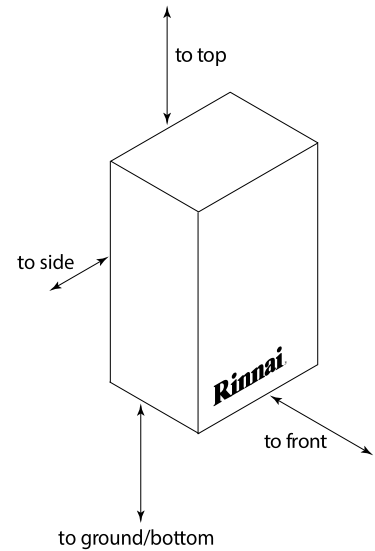

* 0 inches from vent components and condensate drain line.
The clearance for servicing is 24 inches in front of the water heater.
For V53i closet installation: clearance is 6 inches (152 mm) from the front.

Attachment of the Water Heater

- Identify the installation location and confirm that the installation will meet all required clearances.
- Securely attach the water heater to the wall using any of the holes in the wall installation brackets which are at the top and bottom of the water heater. Ensure that the attachment strength is sufficient to support the weight. Refer to the weight of the water heater in the Specifications section.

NOTE: Rinnai water heaters should be installed in an upright position. Do not install upside down or on its side.

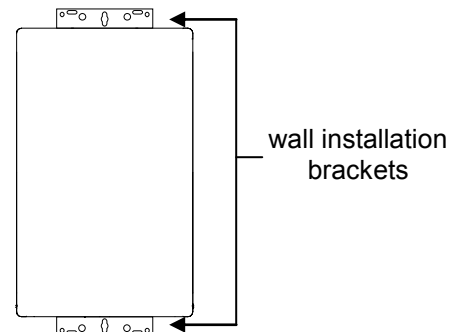

Electrical Connection

RV53i

The water heater requires 120 VAC, 60 Hz power from a properly grounded circuit.

If using the 6 foot long power cord, plug it into a standard 3 prong 120 VAC, 60 Hz properly grounded wall outlet.

The wiring diagram is located on the Technical Sheet attached to the inside of the front cover.

The water heater must be electrically grounded in accordance with local codes, or in the absence of local codes with the *National Electrical Code*, ANSI/NFPA 70 and/or the CSA C22.1, *Canadian Electrical Code*.

RV53e

The water heater must be electrically grounded in accordance with local codes or in the absence of local codes with the most recent edition of the National Electrical Code, ANSI/NFPA 70. In Canada, all electrical wiring should be in accordance with local codes and the Canadian Electrical Code, CSA C22.1 Part 1. Do not rely on the gas or water piping to ground the water heater. A screw is provided in the junction box for the grounding connection.

The water heater requires 120 VAC, 60 Hz power from a properly grounded circuit.

A disconnect switch must be provided and installed for the incoming 120 VAC power. It should be a type that is suitable for outdoor use. Check the National Electrical Code, ANSI/NFPA 70 and your local codes for a proper switch type to use in your area.

The wiring diagram is located on the Technical Sheet attached to the inside of the front cover.

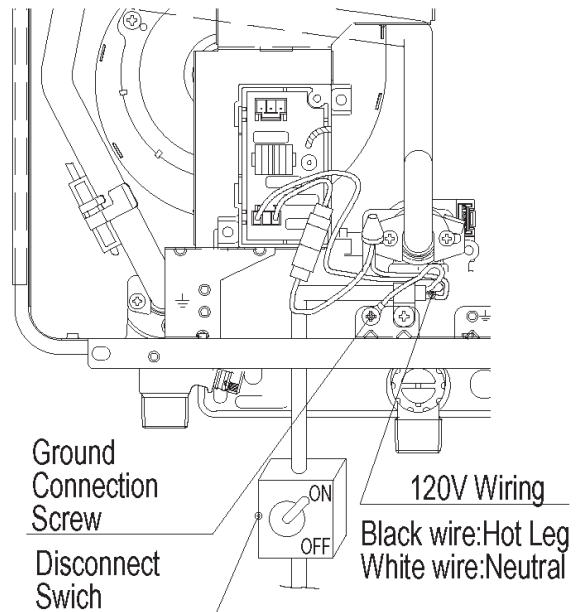

Gas Piping

General Instructions

- A manual gas control valve must be placed in the gas supply line to the Rinnai water heater. A union can be used on the connection above the shut off valve for the future servicing or disconnection of the unit.
- Check the type of gas and the gas inlet pressure before connecting the Rinnai water heater. If the Rinnai water heater is not of the gas type that the building is supplied with, DO NOT connect the water heater. Contact the dealer for the proper unit to match the gas type.
- Check the gas supply pressure immediately upstream at a location provided by the gas company. Supplied gas pressure must be within the limits shown in the Specifications section.
- Before placing the appliance in operation all joints including the heater must be checked for gas tightness by means of leak detector solution, soap and water, or an equivalent nonflammable solution, as applicable. (Since some leak test solutions, including soap and water, may cause corrosion or stress cracking, the piping shall be rinsed with water after testing, unless it has been determined that the leak test solution is non-corrosive.)
- Always use approved connectors to connect the unit to the gas line. Always purge the gas line of any debris before connection to the water heater.
- The gas supply line shall be gas tight, sized, and so installed as to provide a supply of gas sufficient to meet the maximum demand of the heater and all other gas consuming appliances at the location without loss of pressure.
- Any compound used on the threaded joint of the gas piping shall be a type which resists the action of liquefied petroleum gas (propane / LPG).
- Refer to an approved pipe sizing chart if in doubt about the size of the gas line.

Gas Piping

Pipe Sizing Procedure - Example

The gas supply must be capable of handling the entire gas load at the location. Gas line sizing is based on gas type, the pressure drop in the system, the gas pressure supplied, and gas line type. For gas pipe sizing in the United States, refer to the *National Fuel Gas Code, NFPA 54*. For Canadian gas pipe sizing, refer to the Natural Gas and Propane Installation Code CAN/CSA B149.1. The below information is provided as an example. The appropriate table from the applicable code must be used.

- For some tables, you will need to determine the cubic feet per hour of gas required by dividing the gas input by the heating value of the gas (available from the local gas company). The gas input needs to include all gas products at the location and the maximum BTU usage at full load when all gas products are in use.

$$\text{Cubic Feet per Hour (CFH)} = \frac{\text{Gas Input of all gas products (BTU / HR)}}{\text{Heating Value of Gas (BTU / FT}^3\text{)}}$$

- Use the table for your gas type and pipe type to find the pipe size required. The pipe size must be able to provide the required cubic feet per hour of gas or the required BTU/hour.

Example: The heating value of natural gas for your location is 1000 BTU/FT³. The gas input of the RV53i is 150,000 BTU/HR. Additional appliances at the location require 114,000 BTU/hr. Therefore the cubic feet per hour = (150,000 + 114,000) / 1000 = 264 FT³/HR. If the pipe length is 10 feet then the 3/4 inch pipe size is capable of supplying 264 FT³/HR of natural gas.

Pipe Sizing Table - Natural Gas				
Schedule 40 Metallic Pipe				
Inlet Pressure: less than 2 psi (55 inches W.C.)				
Pressure Drop: 0.3 inches W.C.				
Specific Gravity: 0.60				
Capacity in cubic feet per hour				

Length	Pipe Size (inches)			
	3/4	1	1 1/4	1 1/2
10	273	514	1060	1580
20	188	353	726	1090
30	151	284	583	873
40	129	243	499	747
50	114	215	442	662
60	104	195	400	600
70	95	179	368	552
80	89	167	343	514
90	83	157	322	482
100	79	148	304	455
125	70	131	269	403
150	63	119	244	366
175	58	109	224	336
200	54	102	209	313

Pipe Sizing Table - Propane Gas				
Schedule 40 Metallic Pipe				
Inlet Pressure: 11.0 inches W.C.				
Pressure Drop: 0.5 inches W.C.				
Specific Gravity: 1.50				
Capacity in Thousands of BTU per Hour				

Length	Pipe Size (inches)			
	1/2	3/4	1	1 1/4
10	291	608	1150	2350
20	200	418	787	1620
30	160	336	632	1300
40	137	287	541	1110
50	122	255	480	985
60	110	231	434	892
80	101	212	400	821
100	94	197	372	763
125	89	185	349	716
150	84	175	330	677
175	74	155	292	600
200	67	140	265	543

Isolation Valves and Pressure Relief Valve

The isolation valves provide the ability to isolate the water heater from the structure's plumbing and allow quick access to flush the heat exchanger. Check with local codes to determine if a pressure and temperature relief valve is required. The included valves meet *American National Standard (ANSI Z21.10.3)* / *Canadian Standard (CSA 4.3)* and are ANSI/NSF 65 approved for potable water.

Isolation Valve (Cold)	107000081
Isolation Valve (Hot)	107000083
RV53i Pressure Relief Valve (PRV)	107000085
RV53e Pressure Relief Valve (PRV)	107000086

Isolation Valves Installation Instructions:

1. Wrap the ends of the threaded water inlet & outlet on the tankless water heater, as well as the threaded end of the approved pressure relief valve with a minimum of 5 wraps of Teflon® tape.
2. Screw the pressure relief valve into the 3/4" threads opposite the wing handle on the HOT water service valve. (RED drain handle) (see Pressure Relief Valve Section for proper installation requirements)
3. Loosen the 3/4" union nut on the HOT water valve and connect to the HOT water outlet on the tankless water heater. If nut is removed, ensure that you realign the tailpiece accurately to the valve and that the black washer is positioned such that the raised metal edge of the valve is inside the washer.
4. Align the direction of the HOT water drain to the desired position.
5. Tighten the union assembly to the HOT water valve using approximately 15 foot lbs of torque.
6. Repeat steps 3-5 for the COLD water valve. (BLUE drain handle) for connection to the COLD water inlet on the tankless water heater.
7. Connect the INLET on the COLD water valve to the MAIN SOURCE of the water supply.
8. Connect the OUTLET on the HOT water valve to the HOT WATER plumbing system.
9. Ensure that both drain valve lever handles are in the closed position (perpendicular to the drain portion of the body).

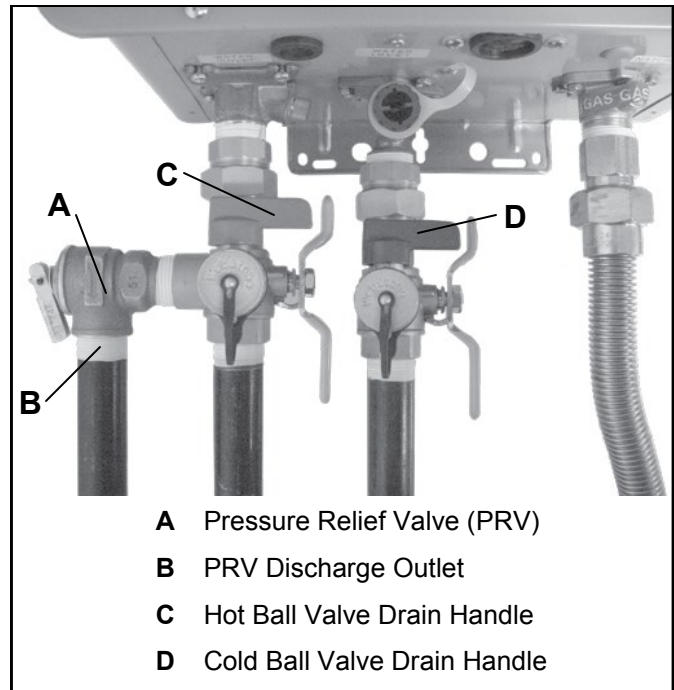

Pressure Relief Valve Installation Instructions:

The PRV must be connected by the threaded connection opposite the wing handle on the hot water valve (designated by the RED drain handle) or the threaded connection on the side of the relocation fitting above the hot water valve. Installation must maintain a 3/4" port size with no shut off valve or line restriction in-between the appliance and the PRV. The discharge line from the PRV should pitch downward and terminate 6" above drains where discharge will be clearly visible. The discharge end of the line shall be plain (unthreaded) and a minimum of 3/4" in diameter. The discharge line material must be suitable for water at least 180° Fahrenheit and can be no more than 30 feet in length and contain no more than 4 elbows or bends. No valve of any type may be installed in the discharge line of the pressure relief valve.

Pressure Relief Valve Maintenance:

For proper care of this approved pressure relief valve, it is recommended that the valve is manually operated once a year. In doing so, it will be necessary to take precautions with regard to the discharge of potentially scalding hot water under pressure. Ensure discharge has a place to flow. Contact with your body or other property may cause damage or harm. Please note that only the PRV in this package is certified by CSA International as an approved item.

General Instructions

- A manual water control valve must be placed in the water inlet connection to the Rinnai water heater before it is connected to the water line. Unions may be used on both the hot and cold water lines for future servicing and disconnection of the unit.
- The piping (including soldering materials) and components connected to this appliance must be approved for use in potable water systems.
- Purge the water line to remove all debris and air. Debris will damage the Rinnai water heater.
- Toxic chemicals such as those used for boiler water treatment are not to be introduced to the potable water used for space heating.
- If the appliance will be used as a potable water source, it must not be connected to a system that was previously used with a nonpotable water heating appliance.
- Ensure that the water filter on the Rinnai water heater is clean and installed.

Pressure Relief Valve

- An approved pressure relief valve is required by the *American National Standard (ANSI Z21.10.3)* / *Canadian Standard (CSA 4.3)* for all water heating systems, and shall be accessible for servicing.
- The relief valve must comply with the standard for *Relief Valves and Automatic Gas Shutoff Devices for Hot Water Supply Systems ANSI Z21.22* and /or the standard *Temperature, Pressure, Temperature and Pressure Relief Valves and Vacuum Relief Valves, CAN1-4.4*.
- The relief valve must be rated up to 150 psi and to at least the maximum BTU/hr of the appliance.
- The discharge from the pressure relief valve should be piped to the ground or into a drain system to prevent exposure or possible burn hazards to humans or other plant or animal life. Follow local codes. Water discharged from the relief valve could cause severe burns instantly, scalds, or death.
- The pressure relief valve must be manually operated once a year to check for correct operation.
- The relief valve should be added to the hot water outlet line and near the hot water outlet according to the manufacturer's instructions. DO NOT place any other type valve or shut off device between the relief valve and the water heater.
- Do not plug the relief valve and do not install any reducing fittings or other restrictions in the relief line. The relief line should allow for complete drainage of the valve and the line.
- If a relief valve discharges periodically, this may be due to thermal expansion in a closed water supply system. Contact the water supplier or local plumbing inspector on how to correct this situation. Do not plug the relief valve.
- Neither Rinnai nor the *American National Standard (ANSI Z21.10.3)* / *Canadian Standard (CSA 4.3)* requires a combination temperature and pressure relief valve for this appliance. However, local codes may require a combination temperature and pressure relief valve.

Freeze Protection

The freeze protection features include electrical heating elements. Freeze protection may be disabled if electricity is not supplied, or if there is an error preventing the water heater from functioning. Loss of freeze protection may result in water damage from a burst heat exchanger or water lines.

The installation of auto drain down solenoid valves is optional. However, Rinnai strongly recommends that these valves be installed to prevent damage from freezing in case the normal freeze protection should become disabled. Any product damage due to freezing will not be covered by the warranty.

In addition, the solenoid valves should be connected electrically to a surge protector with terminals. This allows the solenoid valves to operate if the water heater is disabled due to an error code.

The solenoid valves and surge protector with terminals are available for purchase at Rinnai.

The freeze protection features will not prevent the external piping from freezing. Rinnai recommends heat tracing and insulating hot and cold water pipes connecting units. Pipe cover enclosures may be packed with insulation for added freeze protection.

With electrical power supplied, Rinnai water heaters will not freeze when the outside air temperature is as cold as -22°F (-30°C) for indoor models or is as cold as -4°F (-20°C) for outdoor models, when protected from direct wind exposure. Because of the "wind-chill" effect, any wind or circulation of the air on the unit will reduce its ability to freeze protect.

Freeze Protection Methods

Manual draining of the water heater



WARNING

To avoid burns, wait until the equipment cools down before draining the water. The water in the appliance will remain hot after it is turned off.

If the water heater is not going to be used during a period of possible freezing weather, it is recommended that the water inside the water heater be drained.

To manually drain the water:

1. Shut off cold water supply and gas supply.
2. Turn off the temperature controller.
3. Disconnect the power to the water heater.
4. Open hot water drain plug at the hot water outlet.
5. Remove water filter to drain the cold water.

If an isolation kit is installed, remove the drain caps on both isolation valves and open both valves above the caps (blue and red valve handles).

To resume normal operation:

1. Confirm that all water drain plugs are removed, that the gas supply is turned off, and that all taps are closed.
2. Screw in the hot water drain plug.
3. Screw in the water filter in the cold water inlet.

If the isolation kit was used to drain the unit, replace the drain caps and close both isolation valves (blue and red valve handles).

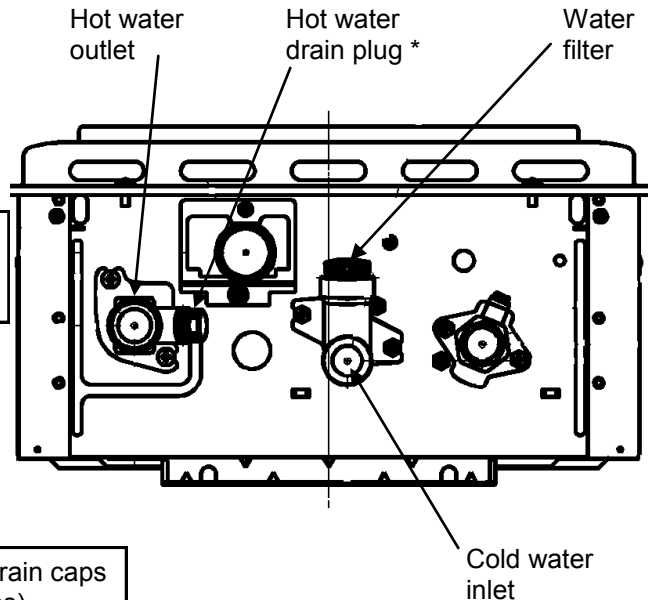

* Use a wrench or other tool to unscrew the hot water drain plug.

4. Open the cold water supply.
5. Open a tap and confirm that water flows, and then close.
6. Turn on the power.
7. After confirming that the temperature controller is off, turn on the gas supply.
8. Turn on the temperature controller.

Running a low volume of water through the water heater to prevent freezing

If the temperature exceeds the ability of the water heater to freeze protect itself, or if power is lost, the following steps may prevent the water heater and external piping from freezing. (Units connected with MSA or EZConnect should be drained to prevent freezing if not in use.)

1. Turn the water heater off.
2. Close the gas supply valve.
3. Reduce the flow to about 0.1 gal/min or to where the stream is about 0.2 inches thick.

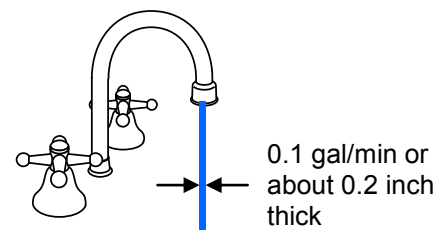

When the water heater or external piping has frozen

1. Do not operate the water heater if it or the external piping is frozen.
2. Close the gas and water valves and turn off the power.
3. Wait until the water thaws. Check by opening the water supply valve.
4. Check the water heater and the piping for leaks.

Freeze Protection Piping

NOTICE

Warranty does not cover damage due to freezing.

In the event of a power failure at temperatures below freezing the water heater should be drained of all water to prevent freezing damage.

The unit may be drained manually. However, Rinnai highly recommends that drain down solenoid valves be installed that will automatically drain the unit if power is lost. Rinnai also recommends the installation of a surge protector with terminals which allows the solenoid valves to operate if the unit is disabled due to an error code.

When the electrical power to the water heater fails, the 3/4" solenoid valve closes (stopping the flow of water into the heater) and the 1/2" solenoid valve opens (allowing the water heater and associated piping to drain. Ensure that you run the drain for the solenoids to the outside environment to prevent discharging water inside the building causing water damage).

NOTE:

Heat trace ALL water pipe and fittings located outside home (attic, crawl space) or building structure. (ALL water pipe and fittings shown above the dashed line in the drawing.)

NOTE:

ALL pipe and fittings shown below dashed line should be located inside home or building structure.

The vacuum breaker line should be located inside the building structure.

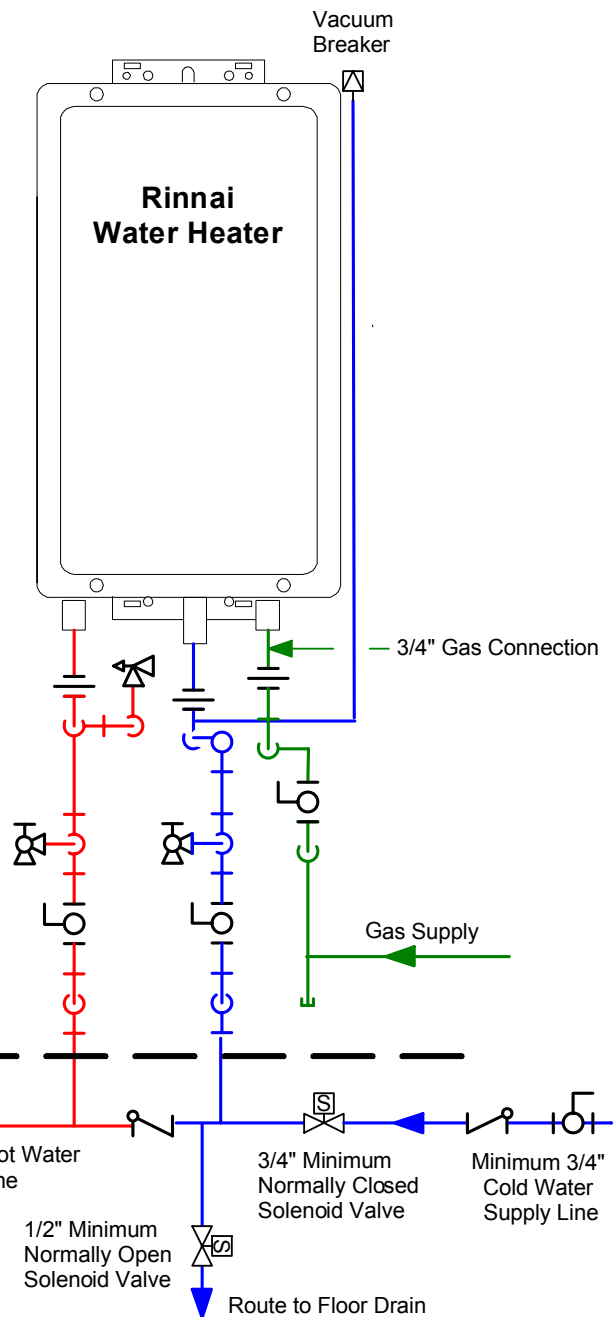

KEY

	3/4" Ball Valve		Pressure Regulator
	3/4" Union		Circulating Pump
	Check Valve		Boiler Drain Valve
	Pressure Relief Valve		Solenoid Valve

This is not an engineered drawing. It is intended only as a guide and not as a replacement for professionally engineered project drawings. This drawing is not intended to describe a complete system. It is up to the contractor/engineer to determine the necessary components and configuration of the particular system being installed. This drawing does not imply compliance with local building code requirements. It is the responsibility of the contractor/engineer to ensure installation is in accordance with all local building codes. Confer with local building officials before installation.

Error Indication or Air Handler Control Switch (RV53i)







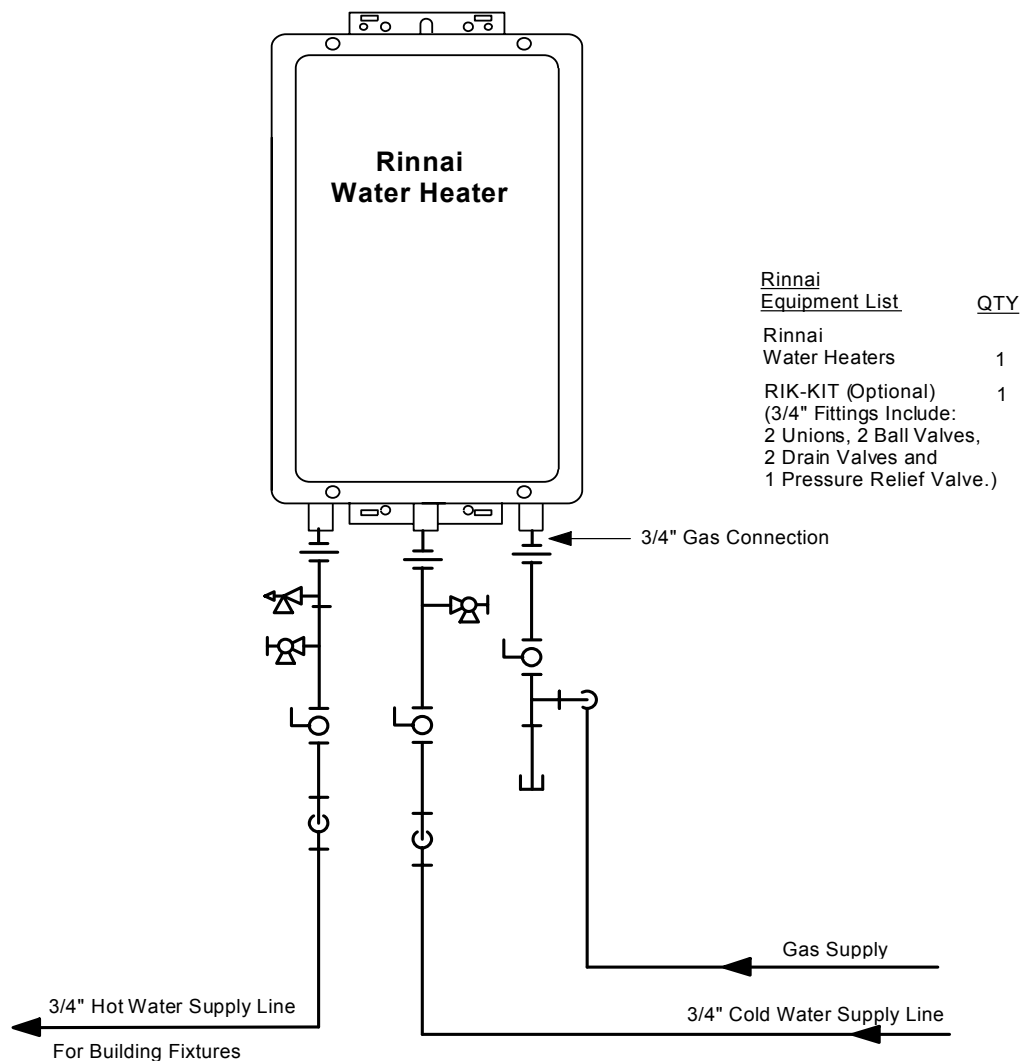

When using the Rinnai water heater with an Error Indication Switch, switch No. 4 in the bank of 8 switches should be in the off position. This is the default position.

To connect the water heater to the Rinnai Air Handler, the Control Switch is necessary to function as the electrical connection. When the Control Switch is functioning as the electrical connection between the water heater and air handler, switch No. 4 in the bank of 8 switches should be in the on position.

The Error Indication Switch and the Rinnai Air Handler Control Switch are optional products available from Rinnai. Installation instructions are included with these products.

Recommended Piping for Basic Installation



KEY		This is not an engineered drawing. It is intended only as a guide and not as a replacement for professionally engineered project drawings. This drawing is not intended to describe a complete system. It is up to the contractor/engineer to determine the necessary components and configuration of the particular system being installed. This drawing does not imply compliance with local building code requirements. It is the responsibility of the contractor/engineer to ensure installation is in accordance with all local building codes. Confer with local building officials before installation.	
	3/4" Ball Valve		
	3/4" Union		Circulating Pump
	Check Valve		Boiler Drain Valve
	Pressure Relief Valve		Solenoid Valve

Recommended Piping for Circulation Systems

NOTE:

This piping arrangement maintains full warranty.

For this application:

Pump should be controlled by an Aquastat, Timer or Combination Aquastat and Timer.

Pump to be sized to maintain circulation loop temperature.

The pump should be sized to overcome the pressure loss through the tank water heater, and supply and return plumbing. Reference the Rinnai Hot Water System Design Manual, Pump Sizing for Circulation.

Pump to be of bronze or stainless construction.

IMPORTANT: Connect the building return line to the hot water supply line as close as possible to the Rinnai Water Heater.

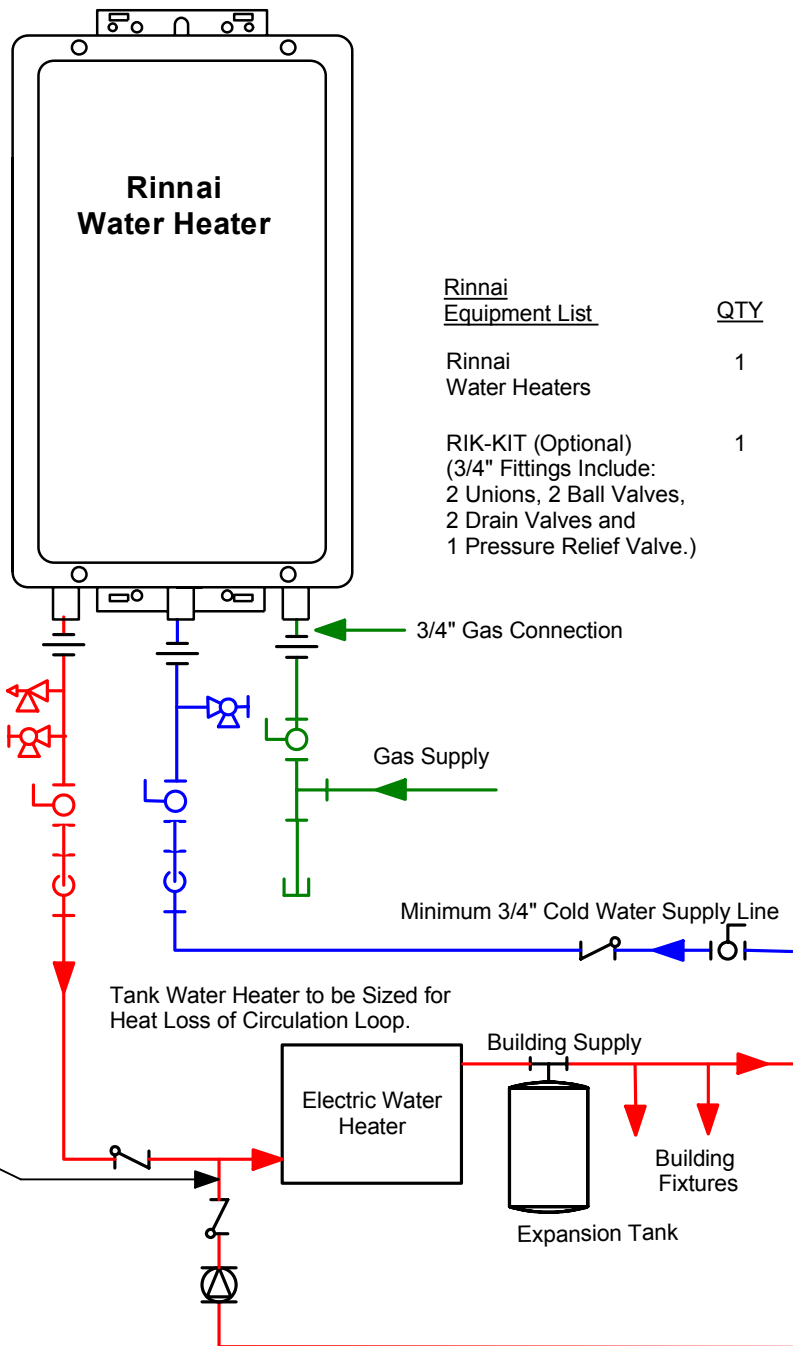

Rinnai Equipment List	QTY
Rinnai Water Heaters	1
RIK-KIT (Optional) (3/4" Fittings Include: 2 Unions, 2 Ball Valves, 2 Drain Valves and 1 Pressure Relief Valve.)	1

Tank Water Heater to be Sized for Heat Loss of Circulation Loop.

KEY

	3/4" Ball Valve		Pressure Regulator
	3/4" Union		Circulating Pump
	Check Valve		Boiler Drain Valve
	Pressure Relief Valve		Solenoid Valve

This is not an engineered drawing. It is intended only as a guide and not as a replacement for professionally engineered project drawings. This drawing is not intended to describe a complete system. It is up to the contractor/engineer to determine the necessary components and configuration of the particular system being installed. This drawing does not imply compliance with local building code requirements. It is the responsibility of the contractor/engineer to ensure installation is in accordance with all local building codes. Confer with local building officials before installation.

Venting Instructions (RV53i)

Intake / Exhaust Guidelines Refer to the specific instructions on your vent product for additional installation requirements.

- This water heater is a direct vent water heater and therefore is certified and listed with the vent system. You must use vent components that are certified and listed with the water heater model.
- Do not combine vent components from different manufacturers.
- The vent system must vent directly to the outside of the building and use outside air for combustion.
- Venting should be as direct as possible with a minimum number of pipe fittings.
- Avoid dips or sags in horizontal vent runs by installing supports per the vent manufacturer's instructions.
- Support horizontal vent runs every four feet and all vertical vent runs every six feet or in accordance with local codes.
- Vent diameter must not be reduced.
- Do not connect the venting system with an existing vent or chimney.
- Do not common vent with the vent pipe of any other water heater or appliance.
- Vent connections must be firmly pressed together so that the gaskets form an air tight seal.
- The vent piece connected to the water heater must be secured with one self-tapping screw.
- Refer to the instructions of the vent system manufacturer for component assembly instructions.
- If the vent system is to be enclosed, it is suggested that the design of the enclosure shall permit inspection of the vent system. The design of such enclosure shall be deemed acceptable by the installer or the local inspector.

NOTICE

If it becomes necessary to access an enclosed vent system for service or repairs, Rinnai is not responsible for any costs or difficulties in accessing the vent system. Warranty does not cover obtaining access to an enclosed vent system.

Condensate

Condensate formation can occur in high efficiency direct vent appliances. To prevent condensate damage follow these instructions.

- Vertical terminations must incorporate a condensate drain and trap as close as possible to the appliance.
- The RV53i water heater has an integrated condensate collector.
- Rinnai offers a condensate trap.
- Regions of cold climate will create more condensate in the vent system. The condensate collector should be used in cold climates.
- Use only vent that is approved and identified as acceptable for your particular model.
- Do not use PVC, CPVC, ABS or galvanized material to vent this appliance.
- Slope the venting toward the appliance according to the vent manufacturers installation instructions.
- All condensate must drain and be disposed of per local codes.
- Use only PVC or CPVC pipe for the condensate drain line.
- The condensate drain pipe should be as short as possible and have a downward pitch.
- Do not connect the condensate drain pipe directly to the rain sewer.

WARNING

The condensate trap must be primed before operation to prevent exhaust gases from entering the building.

NOTICE

Provisions must be made to prevent the condensate from entering the water heater. Without proper drainage or disposal, condensate will damage the heat exchanger.

- The condensate drain pipe (along its entire length) must be at least the same diameter as the drain line.
- The end of the condensate drain pipe should be open to the atmosphere. The end should not be under water or other substances.
- Do not connect the condensate drain line with an air conditioning evaporator coil drain.
- To minimize freezing of the condensate, run the condensate drain line through an interior wall or between insulation and an interior wall.
- The condensate collector should be used for all hydronic heating applications.

Venting Instructions (RV53i)

Maximum Vent Length

1. Determine the number of 90 degree elbows in the vent system. (Two 45 degree elbows count as one 90 degree elbow.)
2. Refer to the table to find the maximum vent length based on the number of elbows.
3. Follow the applicable note.

Example: If you have one elbow then your maximum vent length is 35 feet (10.7 m). If your actual length is greater than 15 ft (4.6 m) then move switch no. 1 (SW1) to OFF.

Number of 90° Elbows						
0	1	2	3	4	5	6
41 ft ① (12.5 m)	35 ft ② (10.7 m)	29 ft ③ (8.8 m)	23 ft ④ (7.0 m)	17 ft ④ (5.2 m)	11 ft ④ (3.4 m)	5 ft ④ (1.5 m)

- ① If the length is greater than 21 ft (6.4 m) then move switch no. 1 (SW1) to OFF.
- ② If the length is greater than 15 ft (4.6 m) then move switch no. 1 (SW1) to OFF.
- ③ If the length is greater than 9 ft (2.7 m) then move switch no. 1 (SW1) to OFF.
- ④ Move switch no. 1 (SW1) to OFF.

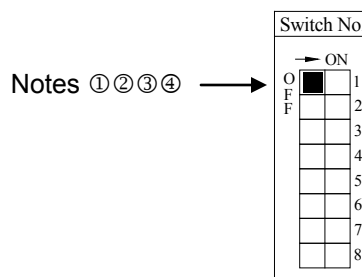

NOTICE

If you have a longer vent length, switch no. 1 is required to be in the OFF position. This ensures the water heater will run properly. Blocked flue error codes and shutdowns may result if switch no. 1 is not in the correct position.

Vent Products

Listed and Tested Vent Products for *RV53i*.....REU-VB2020FFU-US

Manufacturer	Product	Parts
Rinnai/Ubbink	Rolux Vent System	Refer to the manufacturer's technical literature for specific part numbers and instructions.
Heat-Fab	Saf-T Vent SC system	
Metal-Fab	Corr/Guard Vent/Air Intake System	

Vent Manufacturer Contact Information for Installation Instructions and Parts Lists:

Rinnai/Ubbink	Heat-Fab	Metal-Fab Inc.
Telephone: 800-621-9419	Telephone: 800-772-0739	Telephone: 800-835-2830
Fax: 678-829-1666	Fax: 413-863-4803	316-943-2351
Web Site: www.rinnai.us	E-mail: custsvc@heat-fab.com	Fax: 316-943-2717
	Web Site: www.heatfab.com	E-mail: info@mtifab.com
		Web Site: www.metal-fabinc.com

Horizontal Termination without using the Condensate Collector

⚠ WARNING

If the condensate collector is not used, the drain pipe must be capped to prevent exhaust gases and condensate from entering the building. The cap is supplied on the appliance.

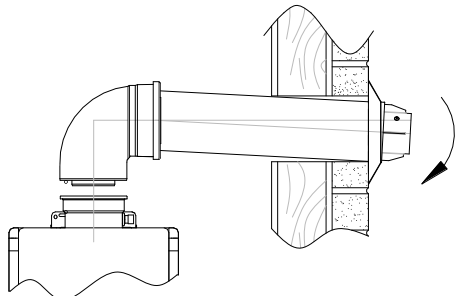

* The condensate collector must be used in horizontal terminations if a vertical rise in the vent system exceeds 5ft.

Maximum Height *
5 feet (1.52 m)

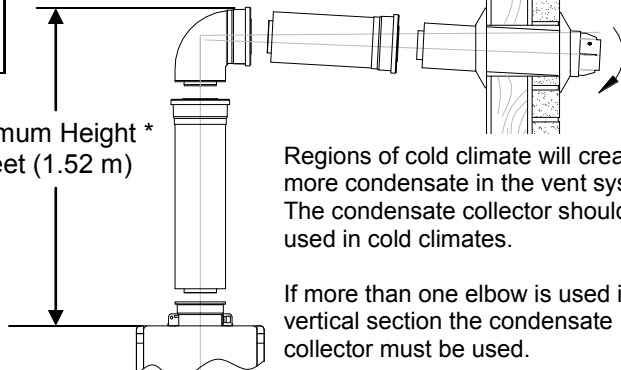

Regions of cold climate will create more condensate in the vent system. The condensate collector should be used in cold climates.

If more than one elbow is used in the vertical section the condensate collector must be used.

Horizontal Termination using the Condensate Collector

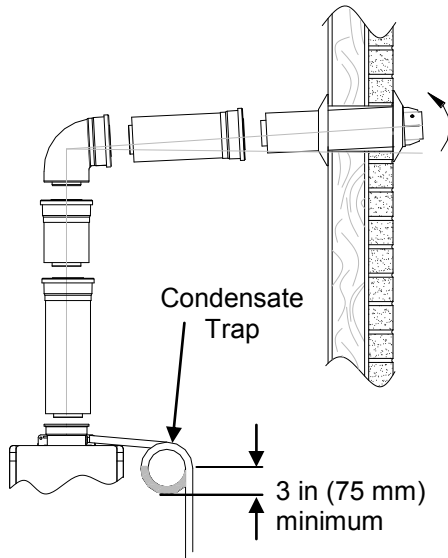

Condensate Trap

3 in (75 mm) minimum

Vertical Termination

(condensate collector must be used in all installations)

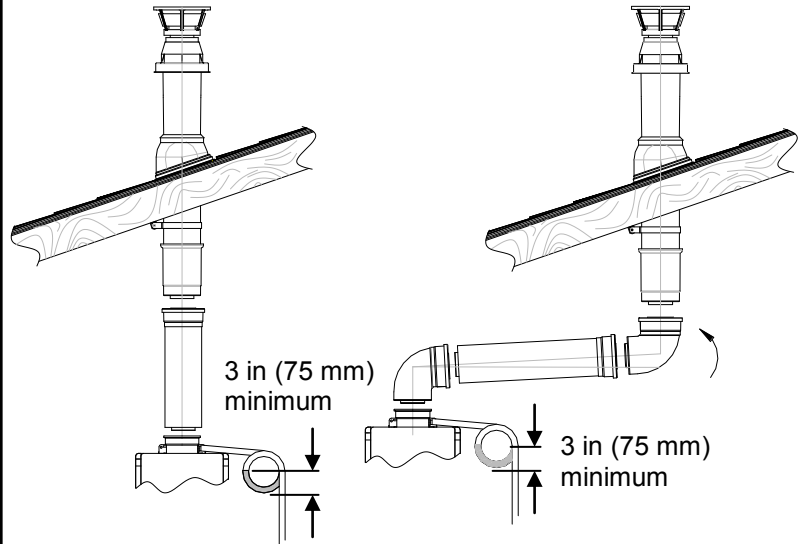

3 in (75 mm) minimum

3 in (75 mm) minimum

Condensate Collector

Bracket

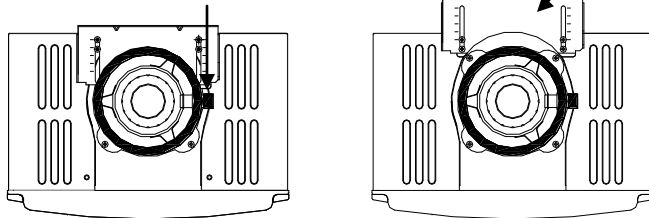

To adjust the condensate collector position or to replace the female vent top with a male vent top:

1. Loosen the 4 screws at the rear bracket
2. Slide the bracket away from the female vent top.
3. Remove the 4 screws attaching the female vent top to the water heater.
4. Lift up the female vent top and reposition as desired (or replace with a male vent top).
5. Install the 4 screws at the vent top and tighten the 4 screws at the bracket.

Securing Screw

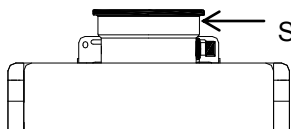

Secure the first vent component to the water heater with one self-tapping screw at the hole located above the condensate collector.

Flue Terminal Clearances (ANS Z21.10.3, CSA 4.3)

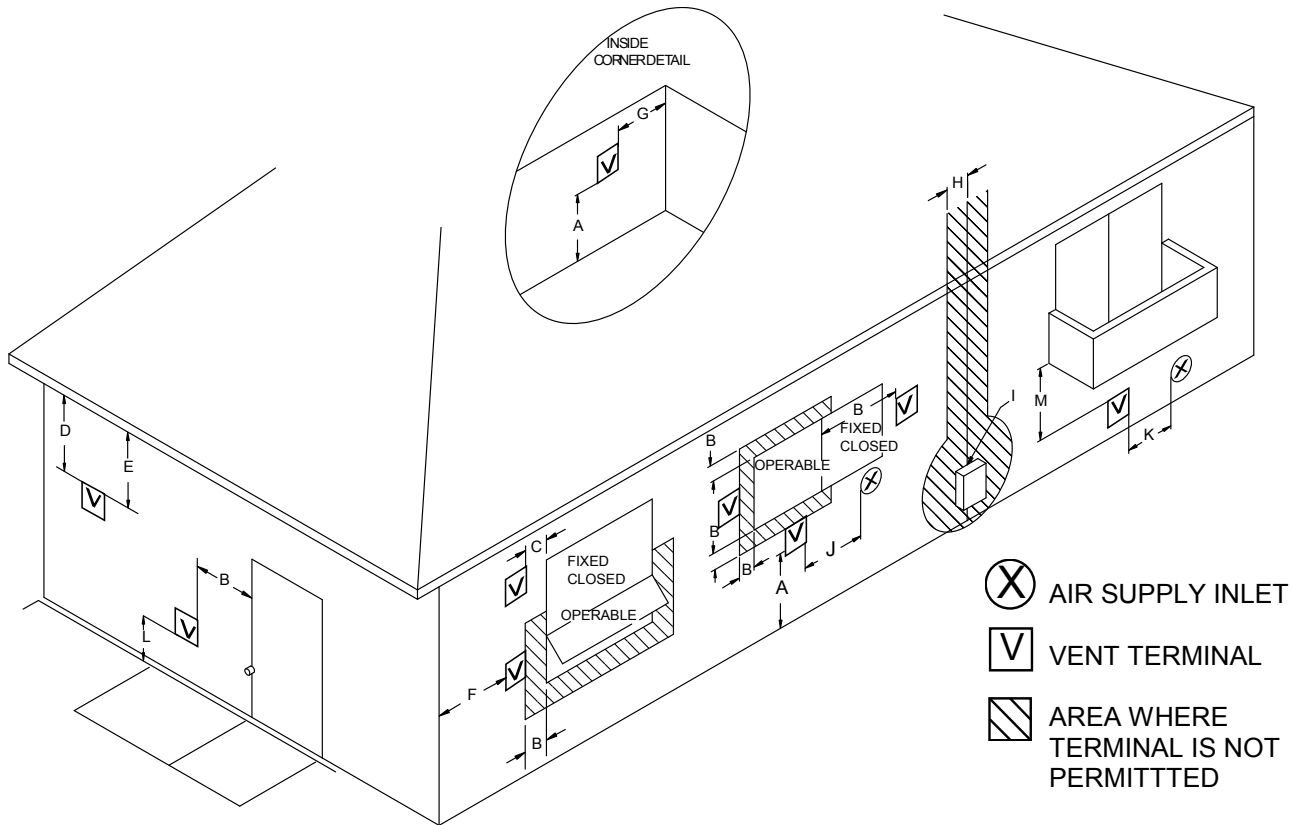

Ref	Description	Canadian Installations	US Installations
A	Clearance above grade, veranda, porch, deck, or balcony	12 inches (30 cm)	12 inches (30 cm)
B	Clearance to window or door that may be opened	36 inches (91 cm)	12 inches (30 cm)
C	Clearance to permanently closed window	*	*
D	Vertical clearance to ventilated soffit, located above the terminal within a horizontal distance of 2 feet (61 cm) from the center line of the terminal	*	*
E	Clearance to unventilated soffit	*	*
F	Clearance to outside corner	*	*
G	Clearance to inside corner	*	*
H	Clearance to each side of center line extended above meter/regulator assembly	3 feet (91 cm) within a height 15 feet (4.5 m) above the meter/regulator assembly	*
I	Clearance to service regulator vent outlet	36 inches (91 cm)	*
J	Clearance to nonmechanical air supply inlet to building or the combustion air inlet to any other appliance	36 inches (91 cm)	12 inches (30 cm)
K	Clearance to a mechanical air supply inlet	6 feet (1.83 m)	3 feet (91 cm) above if within 10 feet (3 m) horizontally
L	Clearance above paved sidewalk or paved driveway located on public property	7 feet (2.13 m) ①	*
M	Clearance under veranda, porch, deck, or balcony	12 inches (30 cm) ②	*

① A vent shall not terminate directly above a sidewalk or paved driveway that is located between two single family dwellings and serves both dwellings.

② Permitted only if veranda, porch, deck, or balcony is fully open on a minimum of two sides beneath the floor.

* For clearances not specified in ANSI Z223.1/NFPA 54 or CSA B149.1, clearances are in accordance with local installation codes and the requirements of the gas supplier.

Clearance to opposite wall is 24 inches (60 cm) for Canada and US.

Additional Clearances

Local codes supersede these clearances.

- Avoid termination locations near a dryer vent.
- Avoid termination locations near commercial cooking exhaust.

 Vent terminal (represents concentric vent terminal)

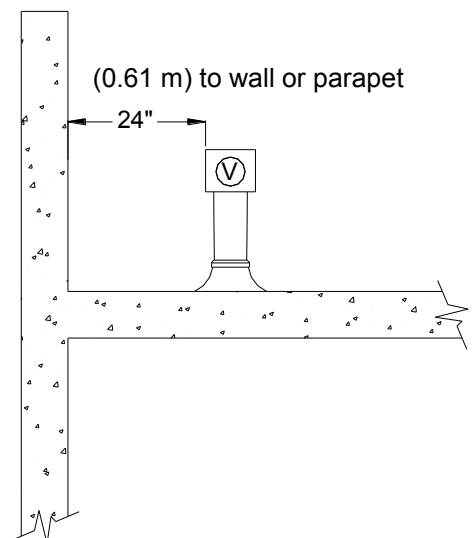
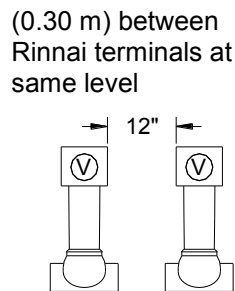
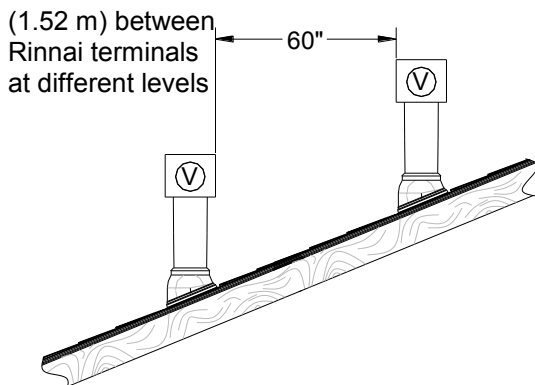
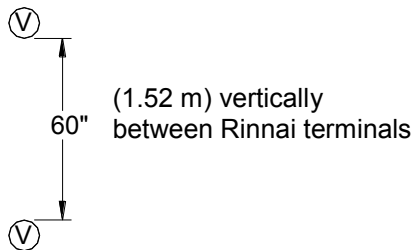
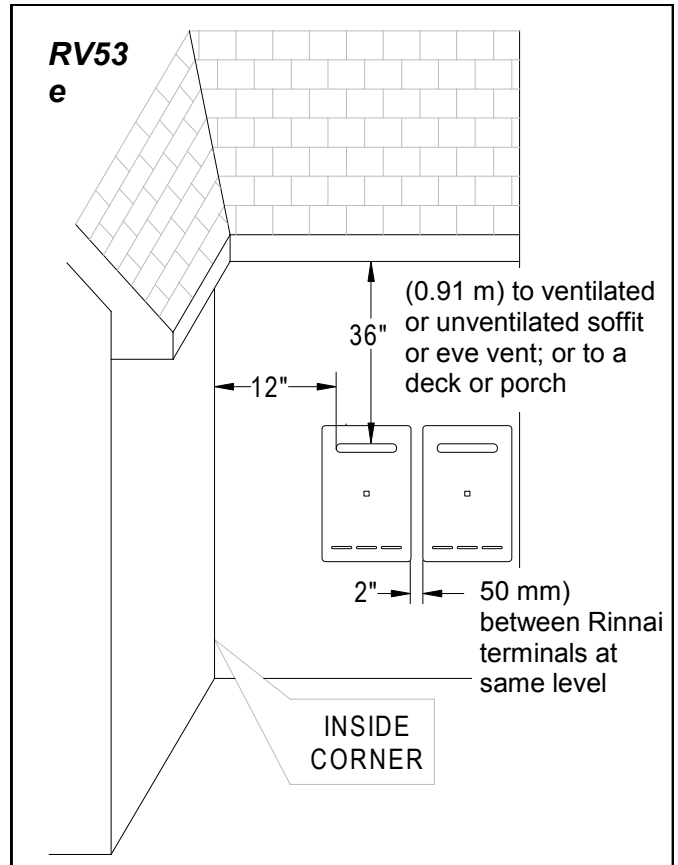
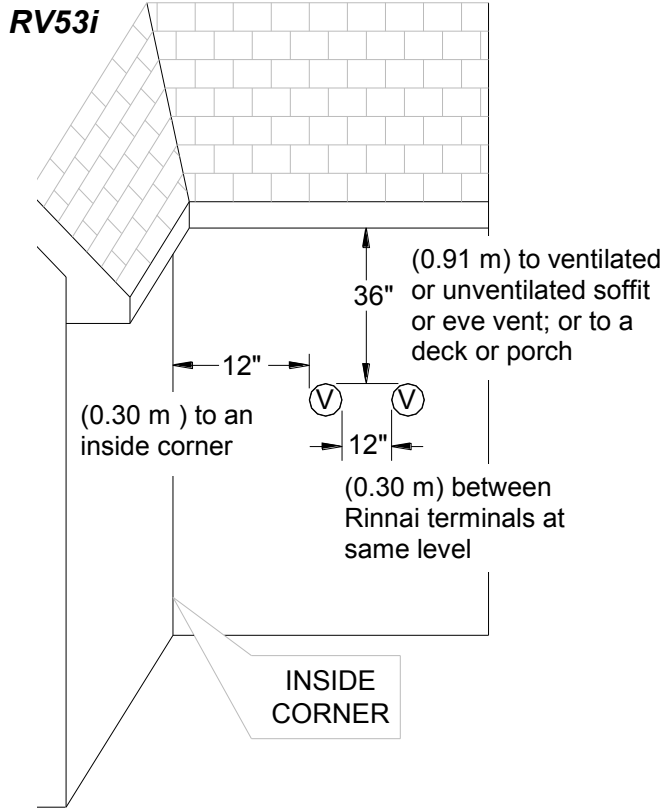

Connecting Multiple Water Heaters

The RV53i can use the EZConnect™ cable which is an optional accessory that connects 2 water heaters and allows them to function as one hot water source.

The RV53i can use the MSA-2M and MSA-2S packs which are optional accessories that connect 2 to 5 water heaters and allow them to function as one hot water source.

The RV53e cannot use the EZConnect, MSA-2MB, and MSA-2S. The RV53e can use Rinnai pressure activation valves (PVA's) can be used to manifold 2 to 5 Rinnai water heaters in order to produce a stable water temperature and allow the water heaters to run efficiently. Water heaters will turn on as necessary to meet the demand for hot water.

Refer to the instructions that come with the accessory for complete installation information.

Number of Connected Water Heaters:	Accessories Necessary:
2	(1) EZConnect™ Cable Or (1) MSA-2M
3	(1) MSA-2M and (1) MSA-2S
4	(1) MSA-2M and (2) MSA-2S
5	(1) MSA-2M and (3) MSA-2S

Guidelines

- Do not install both the EZConnect™ and the MSA packs because they are not designed to operate together.
- Water heaters connected with the EZConnect™ Cable or the MSA-2M and MSA-2S packs cannot be used for the bath fill function.
- Water heaters should be installed less than 18 inches apart so that the cables will reach between units and to prevent temperature fluctuations (cold water sandwich effect) when the water is shut off and turned back on.
- Temperature settings can only be changed on the controller for the primary unit. (This changes the temperature on all units within the MSA or EZConnect™ system.)

High Altitude Installations

Set switches 2 and 3 to the values shown in table below for your altitude. The default setting for the appliance is 0-2000 ft (0-610 m) with switches No. 2 and No. 3 in the OFF position.

WARNING DO NOT adjust the other switches unless specifically instructed to do so.

	0-2000 ft (0-610 m)	2001-5200 ft (610-1585 m)	5201-7700 ft (1585-2347 m)	7701-10200 ft (2347-3109 m)
Switch No. 2	OFF	OFF	ON	ON
Switch No. 3	OFF	ON	OFF	ON

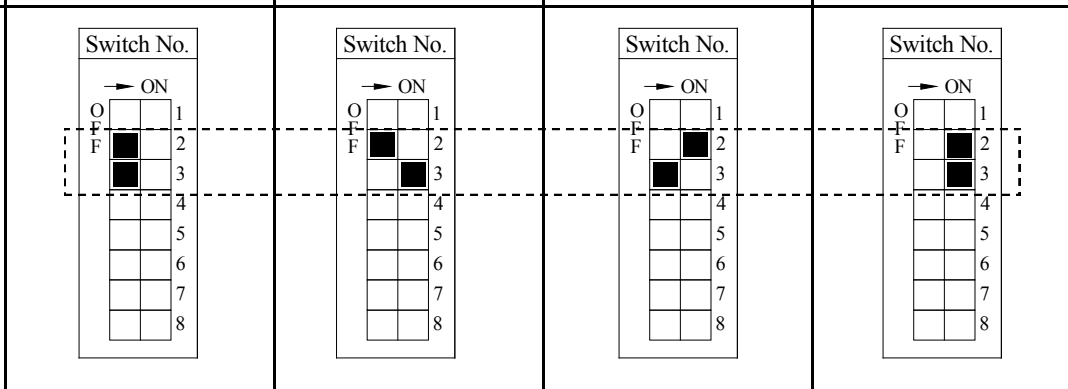

Water Heater High Altitude Installation Setting Procedure 610 - 1372 m (2001 - 4500 ft) for Canada Only / Procédure Reglage de Chaffeu á' Haute Altitude 610 - 1372 m (2001 - 4500 ft) pour Canada Seulement

**All settings/adjustments must be performed by a qualified
Service Technician / Tous réglages/ajustements doivent être
exécutés par un Technicien d'entretien qualifié.**



WARNING DO NOT adjust the other switches unless specifically instructed to do so.

AVERTISSEMENT
NE modifiez PAS la disposition des autres micro-commutateurs sauf sur instructions spécifiques.

1. Turn off the power source and gas supply to the water heater / Coupez l'alimentation de gaz et électrique.
2. Remove the front cover from the water heater/ Enlever la couverture de devant du chauffe-eau.
3. Set the switches 2 and 3 to the values shown in the table below for your altitude. The default setting for the appliance is 0-2000 ft (0-610 m) with switches No. 2 and No. 3 in the OFF position / Régler les micro-commutateurs 2 et 3 aux valeurs montrées dans la table au dessous pour votre altitude. Le réglage de défaut pour l'appareil est 0-2000 ft (0-610 m) avec les commutateurs No 2 et No 3 sur la position OFF.
4. Turn on the gas and power to the water heater / Ouvrez l'alimentation de gaz et électrique.
5. Open a fixture or fixtures to flow water through the water heater at the maximum flow rate obtainable (at least three gallons per minute) / Ouvrir un accessoire ou accessoires pour couler de l'eau par le chauffe-eau au débit maximum procurable (au moins trois gallons par minute).

switch micro- commutateur	0-2000 ft (0-610 m)	2001-4500 ft (610-1372 m)
No 2	OFF	OFF
No 3	OFF	ON

The conversion shall be carried out by a manufacturer's authorized representative, in accordance with the requirements of the manufacturer, provincial or territorial authorities having jurisdiction and in accordance with the requirements of the CAN/CGA-B149.1 or CAN/CGA-B149.2 Installation Codes / La conversion sera exécuté par un représentant du fabricant autorisé, conformément aux conditions du fabricant, les autorités provinciales ou territoriales ayant la juridiction et conformément aux conditions du CAN/CGA-B149.1 ou CAN/CGA-B149.2 Codes d'Installation.

Temperature Controller Installation

Location

- The controller should be out of reach of small children.
- Avoid locations where the controller may become hot (near the oven or radiant heater).
- Avoid locations in direct sunlight. The digital display may be difficult to read in direct sunlight.
- Avoid locations where the temperature controller could be splashed with liquids.
- Do not install in locations where it can be adjusted by the public.

Configurations

A maximum of 4 temperature controllers, including wired and wireless, can be installed for a water heater or bank of water heaters. Controllers can only be wired in parallel. Controllers cannot be wired in series.

The 4 temperature controllers can consist of multiple MC-91's or MC-502RC's but only 1 BC-100V and only 1 MC-100V.

Any one of the 5 types of controllers can be installed by itself and still operate the water heater. All functions will be available with the exception that the clock function on the BC-100V will only be available if an MC-100V is also connected.

If 4 MC-91's are installed, simultaneously press the Priority and On/Off buttons on the fourth controller until a beep sounds.

The table to the right shows some of the possible combinations of controllers.

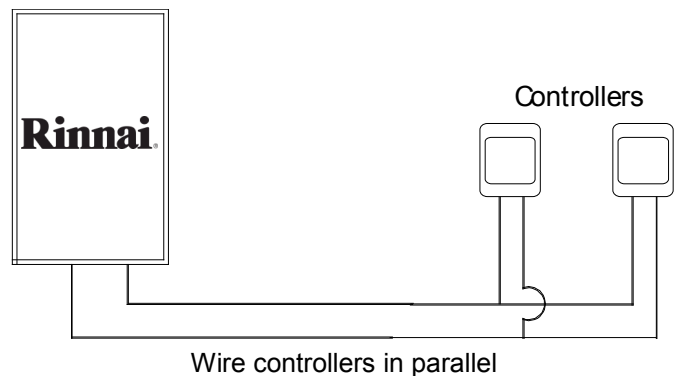

MC-91	+	MC-91	+	MCC-91	+	MC-502RC
MC-91	+	MCC-91	+	MC-502RC	+	MC-502RC
MCC-91	+	MC-502RC	+	BC-100V	+	MC-100V
MC-91	+	MC-502RC	+	BC-100V	+	MC-100V
MC-91	+	MC-91	+	MC-502RC	+	BC-100V
MC-91	+	MC-502RC	+	MC-502RC	+	MC-100V

Cable Lengths and Size

The cable for the temperature controller should be a non-polarized two-core cable with a minimum gauge of 22 AWG. The maximum cable length from each controller to the water heater depends on the total number of wired controllers connected to the water heater.

Number of Wired Controllers	Maximum Cable Length for each Controller to Water Heater
1	328 ft (100 m)
2	164 ft (50 m)
3 or 4	65 ft (20 m)

Temperature Controller Installation

Mounting the Controller (RV53i)

Follow the procedure below to install the MC-91 or MCC-91 temperature controller.

1. Determine a suitable location for the controller.
2. Make three holes in the wall as shown.
3. Run the cable between the controller and the Rinnai water heater or the controller and the other controller.
4. Remove the face plate from the temperature controller using a screwdriver.
5. Connect the cable to the temperature controller.
6. Mount the controller to the wall using the holes drilled in step 2.
7. Disconnect the power from the Rinnai water heater.
8. Remove the cover of the Rinnai water heater.
9. Remove the plastic cover from the PCB and electrical connections.
10. Thread the cable through the access hole at the base of the unit and connect the wires to the controller terminals on the right hand side bottom of the PCB.
11. Secure the controller cable using the clamp provided.
12. Replace plastic cover over PCB and then replace the cover of the Rinnai water heater.

WARNING

Do not attempt to connect the temperature controllers with the power on. There is 120 volt potential, next to the temperature controller connections inside the unit.

Do not connect the temperature controller to the 120VAC terminals provided for the optional solenoid drain valves.

All service and wiring should be performed by a registered installer.

Temperature Controller

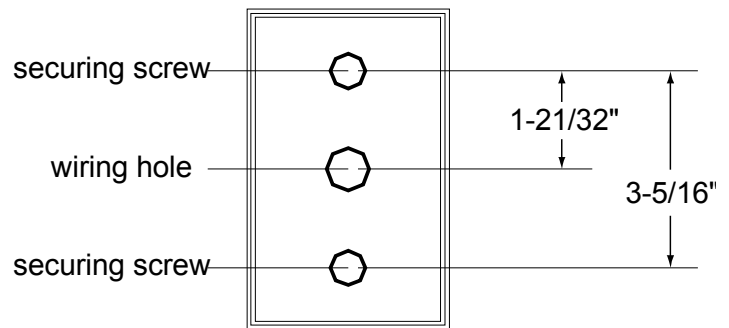

TEMPERATURE CONTROLLER CONNECTION TERMINALS

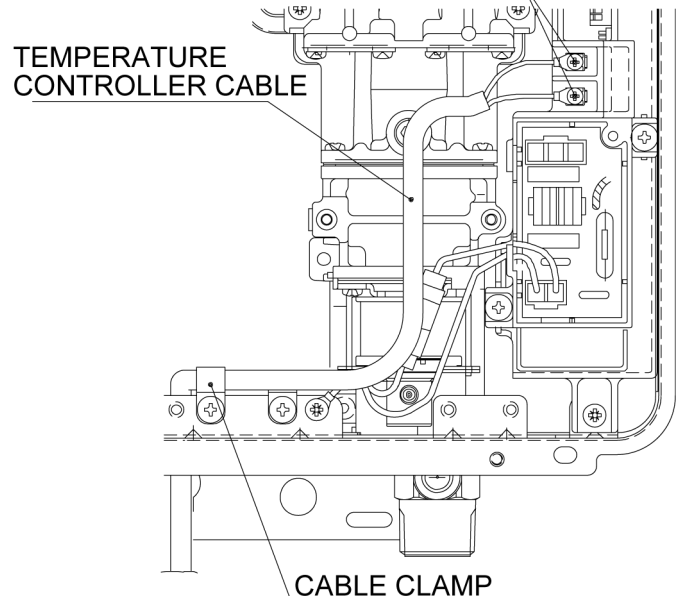

Temperature Controller Installation

WARNING

Do not attempt to connect the temperature controllers with the power on. There is 120 volt potential, next to the temperature controller connections inside the unit.

Do not connect the temperature controller to the 120VAC terminals provided for the optional solenoid drain valves.

All service and wiring should be performed by a registered installer.

Mounting the Controller (RV53e)

Follow the procedure below to install an MC-91 or MCC-91 temperature controller.

1. Determine a suitable location for the controller.
2. Make three holes in the wall as shown.
3. Run the cable between the controller and the Rinnai water heater or the controller and another controller.
4. Remove the face plate from the temperature controller using a screwdriver.
5. Connect the cable to the temperature controller.
6. Mount the controller to the wall using the holes drilled in step 2.

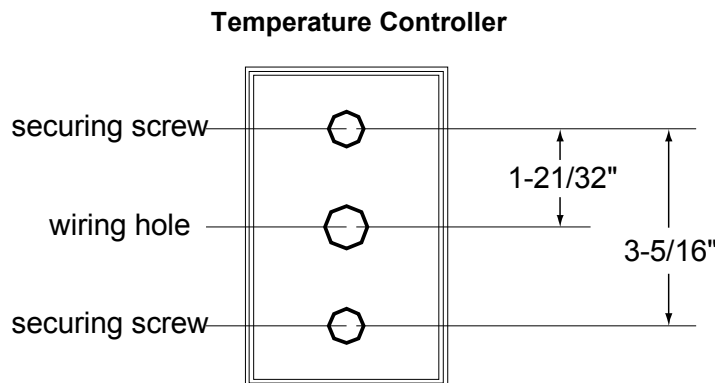

7. Disconnect the power from the water heater.
8. Remove a screw on the Quick Cable Connector. (Fig. 1)
9. To access the cable screws rotate the Quick Cable Connector 90° counterclockwise. (Fig. 2)
10. Loosen the clamp screw and secure wire cable with clamp. The clamp is in the box with the temperature controller. Make sure the length of the wire is long enough. There should be no tension in the wire. (Fig. 3)
11. Loosen 2 cable screws on the terminals for controls and connect the cable. You cannot connect more than 2 cables at a time. When connecting more than 2 cables, connect them in parallel. (Fig. 4)
12. Install the Quick Cable Connection with 1 screw. (Fig. 5)
13. Insert wire cable through the Cable Access Hole so that it can be accessed from the back. (Fig. 2)

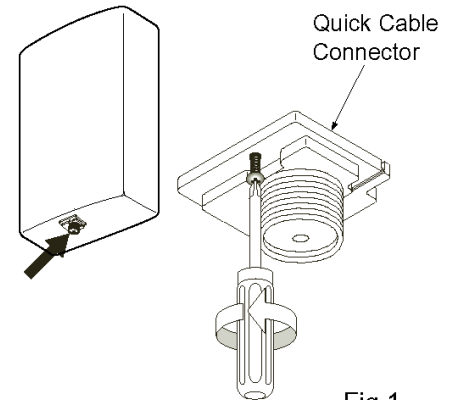

Fig.1

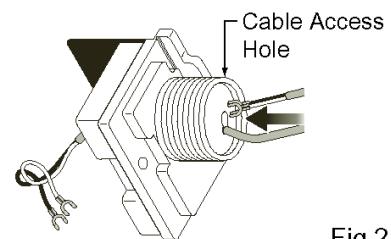

Fig.2

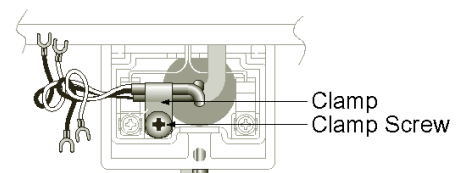

Fig.3

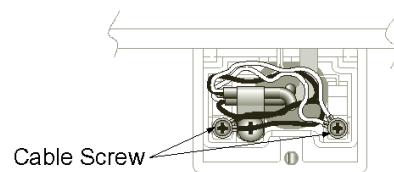

Fig.4

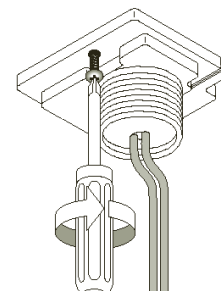

Fig.5

FOR YOUR SAFETY READ BEFORE OPERATING





WARNING

If you do not follow these instructions exactly, a fire or explosion may result causing property damage, personal injury or loss of life.

- A. This appliance does not have a pilot. It is equipped with an ignition device which automatically lights the burner. Do not try to light the burner by hand.
- B. BEFORE OPERATING smell all around the appliance area for gas. Be sure to smell next to the floor because some gas is heavier than air and will settle on the floor.
WHAT TO DO IF YOU SMELL GAS
 - Do not try to light any appliance.
 - Do not touch any electric switch; do not use any phone in your building.
 - Immediately call your gas supplier from a neighbor's phone. Follow the gas supplier's instructions.
- If you cannot reach your gas supplier, call the fire department.
- C. Use only your hand to push in or turn the gas control knob. Never use tools. If the knob will not push in or turn by hand, do not try to repair it, call a qualified service technician. Force or attempted repair may result in a fire or explosion.
- D. Do not use this appliance if any part has been under water. Immediately call a qualified service technician to inspect the appliance and to replace any part of the control system and any gas control which has been under water.

OPERATING INSTRUCTIONS

1. **STOP!** Read the safety information above.
2. Set the thermostat to lowest setting.
3. Turn off all electric power to the appliance using the ON/OFF button.
4. This appliance is equipped with an ignition device which automatically lights the burner. Do not try to light the burner by hand.
5. Locate the manual gas valve on the side of the heater. Turn the manual valve clockwise to the full OFF position. 
6. Wait five (5) minutes to clear out any gas. Then smell for gas, including near the floor. If you smell gas, STOP! Follow "B" in the safety information above. If you don't smell gas, go to the next step.
7. Turn the manual gas valve counterclockwise to the full ON position. 
8. Turn on all electric power to the appliance using the ON/OFF button.
9. Set the thermostat to desired setting.
10. Open a hot water tap. If the appliance will not operate, follow the instructions "To Turn Off Gas To Appliance" and call your service technician or

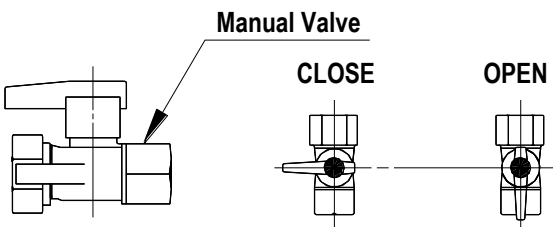

TO TURN OFF GAS TO APPLIANCE

1. Turn off all electric power to the appliance using the ON/OFF button.
2. Set the thermostat to lowest setting.
3. Locate the manual gas valve on the side of the heater. Turn the manual valve clockwise to the full OFF position. 

Technical Data

Pressure Drop Curve

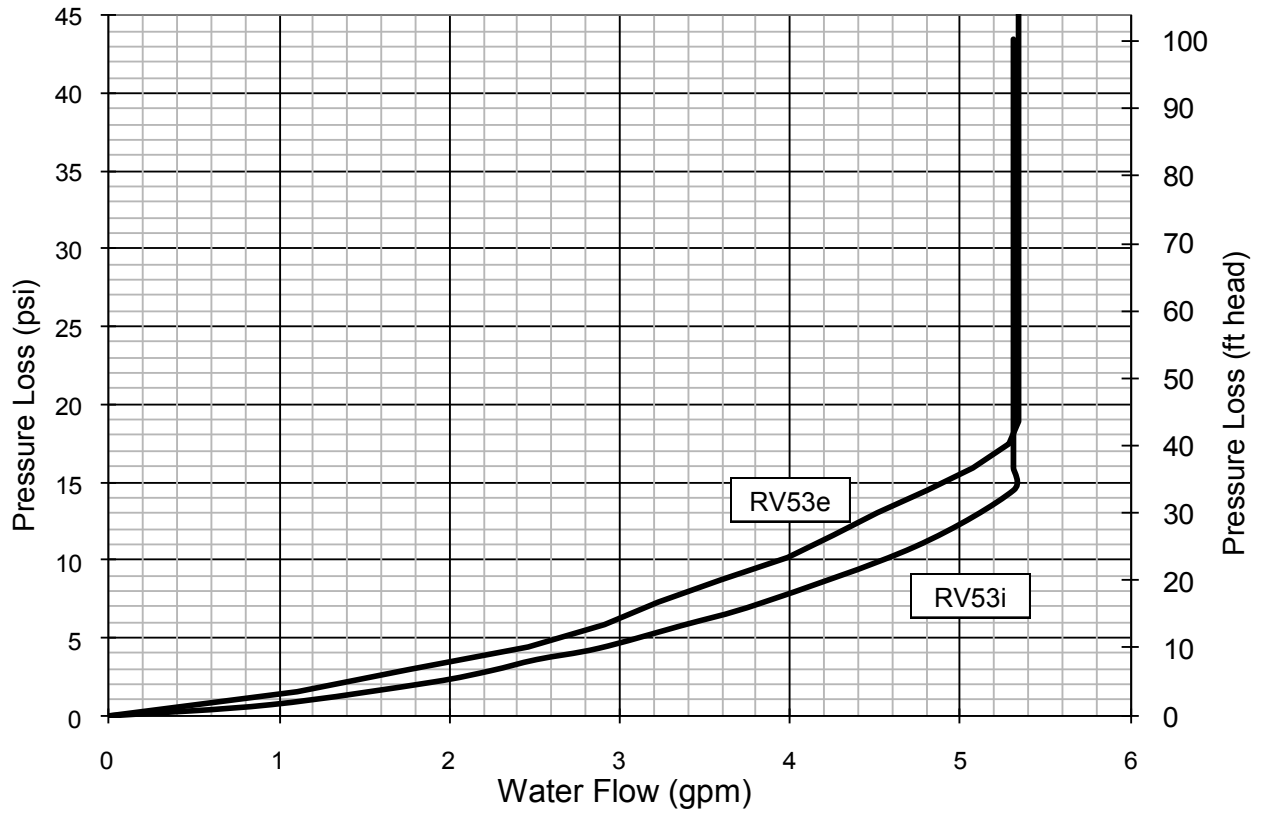

Outlet Flow Data

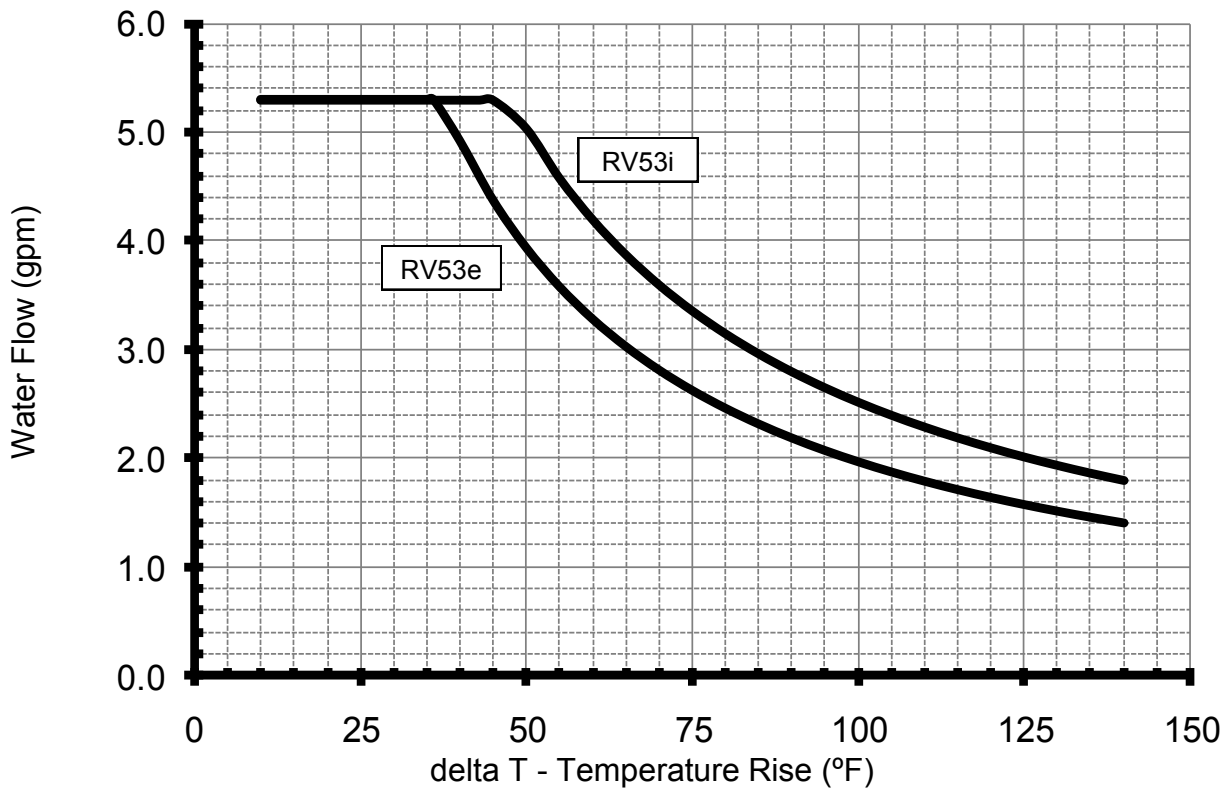

Space Heating

If the water heater is to be used for both water (potable) heating and space heating then the following apply.

- The piping and components connected to the water heater shall be suitable for use with potable water.
- Toxic chemicals, such as used for boiler treatment, shall not be introduced into the potable water.
- The water heater shall not be connected to any heating system or components previously used with a nonpotable water heating appliance.
- When the system requires water for space heating at temperatures higher than required for other uses, a means such as a mixing valve shall be installed to temper the water for other uses in order to reduce the scald hazard potential.

Space heating applications are considered commercial applications for warranty purposes.

Temperature Setting

When using this appliance to provide domestic hot water it is recommended that the domestic hot water temperature be reduced to acceptable temperatures in accordance with local codes. In the absence of local codes it is recommended that the domestic hot water temperature be set to 140° F (60° C) or lower in accordance with UPC 501.6 by using mixing valves or the temperature controller for the water heater.

Pumps

Only use pumps of brass or stainless steel construction. Do not use pumps of iron construction as they will oxidize and clog the inlet filter on the appliance.

Pumps circulating water through the water heater must be sized to overcome the pressure loss through the water heater, the heating system, and any additional plumbing pressure losses. The pressure drop curve based on the water heater model is provided in this manual.

Replacement

When replacing an existing space heating application's water heating source (boiler, tank water heater, tankless water heater, etc.) with Rinnai water heaters, ensure that the water heaters are sized to adequately provide the necessary BTU input for the desired space heating application. Rinnai water heaters are designed to maintain a constant outlet temperature and will supply only the necessary amount of BTU's to maintain that temperature. Depending on the application the maximum BTU rating of the unit may not be achieved. Contact Rinnai's Applications Engineering Department for assistance at (800) 621-9419 ext. 4490.

Iron Components

Do not use Rinnai water heaters directly for space heating applications involving iron radiators or applications with any iron components. Iron components may oxidize creating rust that will clog the inlet filter of the Rinnai water heater.

Dimensions

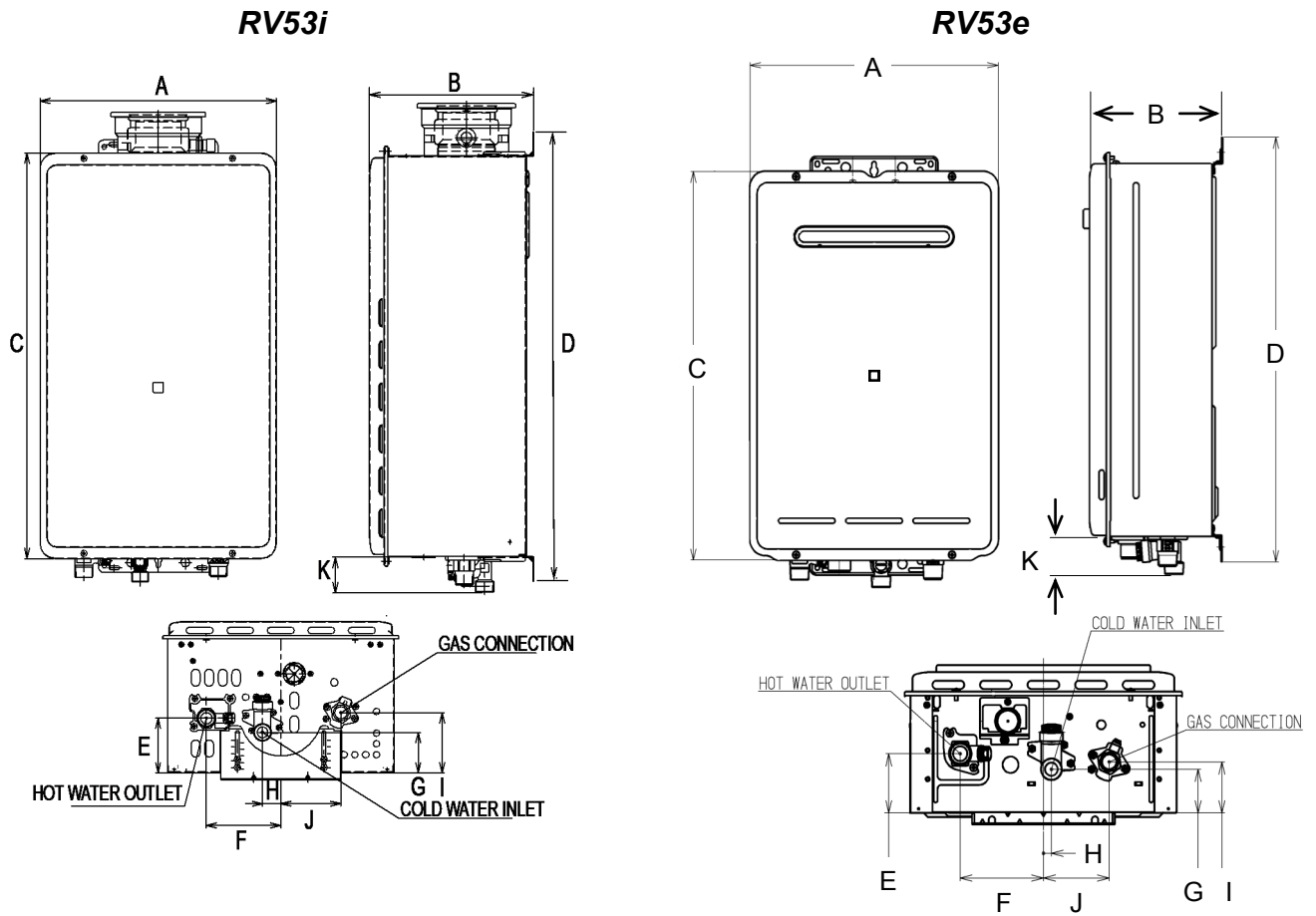

DIM	DESCRIPTION	RV53i in (mm)	RV53e in (mm)
A	Width	13.8 (350)	13.8 (350)
B	Depth *	9.2 (234)	7.3 (186)
C	Height - Unit	23.6 (600)	20.9 (530)
D	Height - with brackets	24.7 (627)	22.5 (571)
E	Hot Water Outlet - from wall *	3.6 (91)	2.8 (72)
F	Hot Water Outlet - from center	4.3 (110)	4.1 (105)
G	Cold Water Inlet - from wall *	2.8 (70)	2.1 (53)
H	Cold Water Inlet - from center	1.1 (27)	0.4 (10)
I	Gas Connection - from wall *	3.9 (99)	2.4 (62)
J	Gas Connection - from center	3.5 (89)	3.3 (83)
K	From base to gas connection	1.6 (41)	1.6 (40)
	From base to cold connection	2.0 (51)	2.0 (50)
	From base to hot connection	1.7 (42)	1.6 (42)

* This is the minimum dimension from the wall. The wall bracket is adjustable to allow an additional 1.57 inches (40 mm).

Ladder Diagrams

RV53i

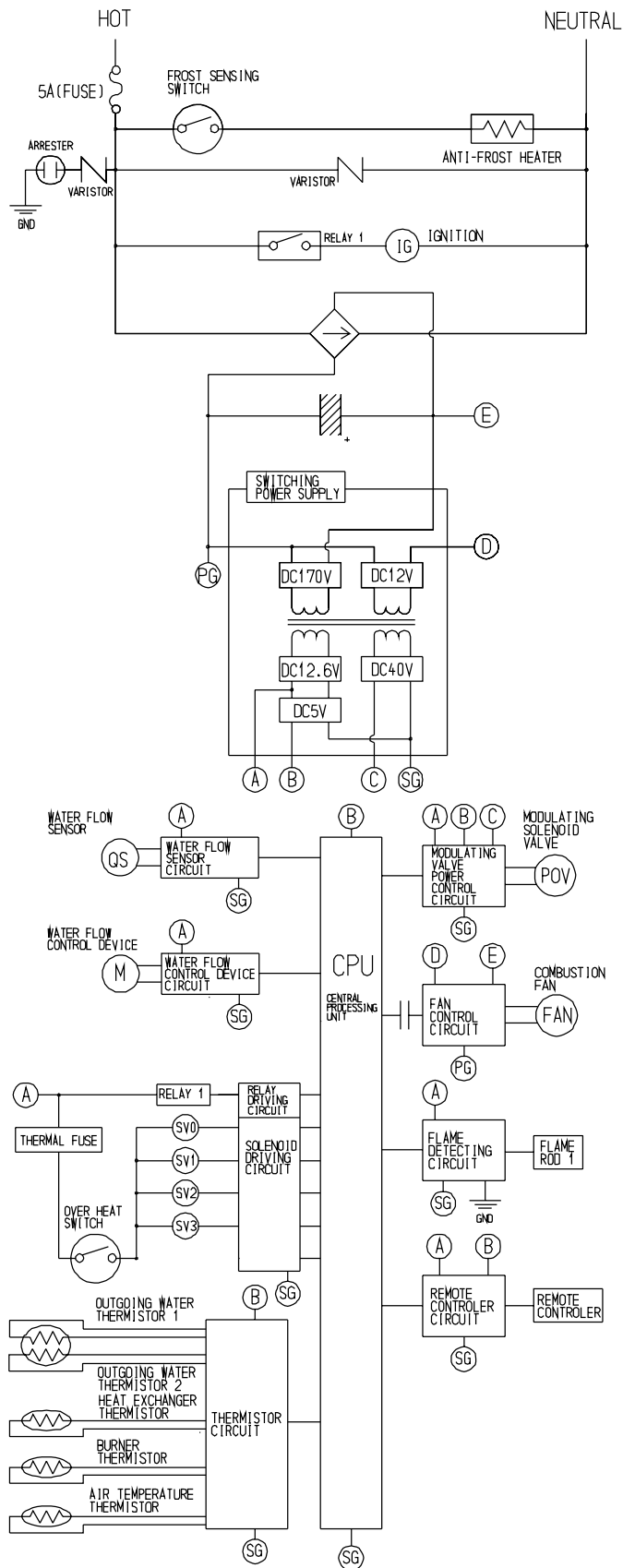

RV53e

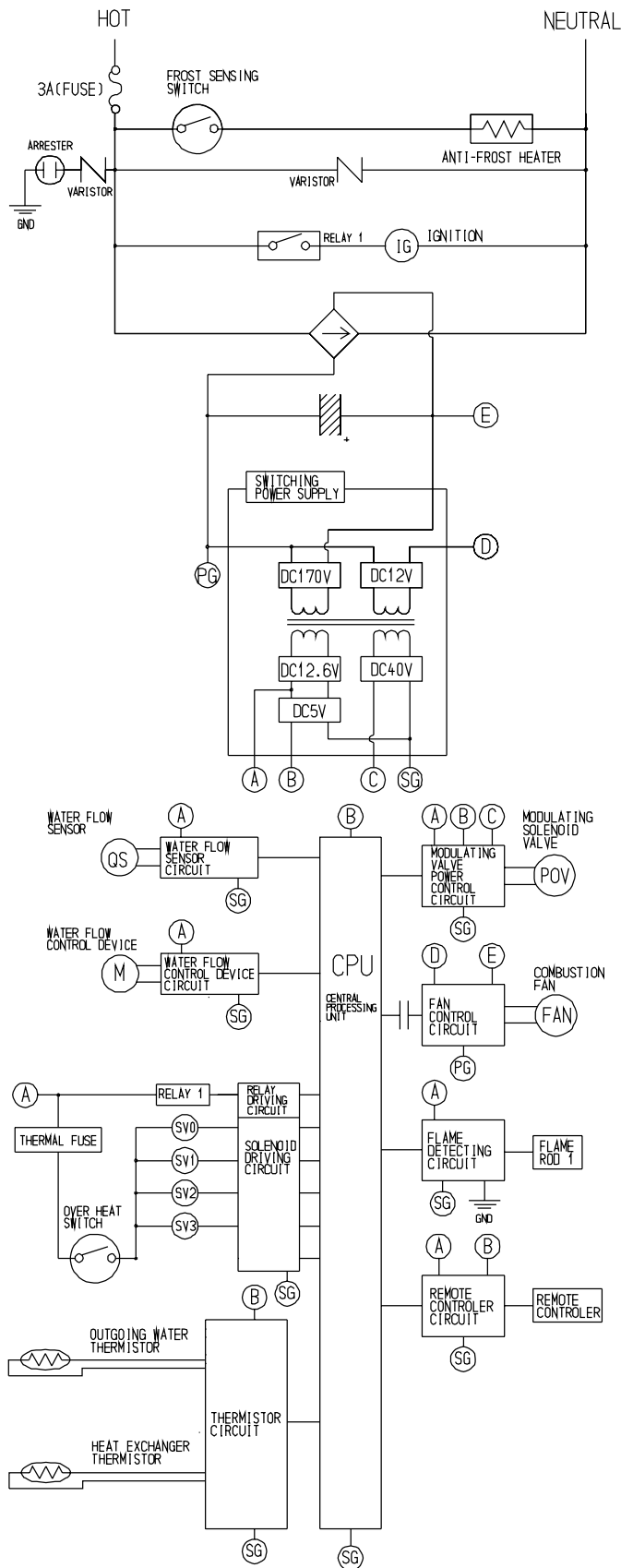

Consumer Support

Warranty Information

The installer is responsible for your water heater's correct installation.

Please complete the information below to keep for your records:

Model No.: _____ Serial No.: _____

Purchased from: _____

Address: _____

Phone: _____ Date of Purchase: _____

Installed by: _____ Installer's License No.: _____

Address: _____ Phone: _____

Date of Installation: _____

Limited Warranty

What is covered?

This Warranty covers any defects in materials or workmanship when the product is installed and operated according to Rinnai written installation instructions, subject to the terms within this Limited Warranty document. This Warranty applies only to products that are installed correctly. Improper installation may void this Warranty. Rinnai strongly suggests that you use a state qualified or licensed installer who has attended a Rinnai product knowledge class before installing this water heater. This Warranty extends to the original purchaser and subsequent owners, but only while the product remains at the site of the original installation. This Warranty only extends through the first installation of the product and terminates if the product is moved or reinstalled at a new location.

How long does coverage last?

Item	RV53i and RV53e Period of Coverage (from date of purchase)		
	Residential Applications or Used with Rinnai Air Handler for domestic heating and water	Used for radiant heating with other than Rinnai Air Handler	Commercial Applications
Heat Exchanger	10 years *	3 years	No coverage
All Other Parts and Components	5 years *	3 years	No coverage
Reasonable Labor	1 year	1 year	No coverage

* Note: Period of coverage is reduced to 3 years from date of purchase when used as a circulating water heater within a hot water circulation loop, where the water heater is in series with a circulation system and all circulating water flows through the water heater, and where an on-demand recirculation system is not incorporated.

On-demand recirculation is defined as a hot water recirculating loop or system that utilizes existing hot and cold lines or a dedicated return line, and only activates when hot water is used. It can be activated by a push button, motion sensor, or voice activation but not by a temperature sensor. A timer added to a standard recirculating pump is not considered as on-demand.

There is no warranty coverage on product installed in a closed loop application, commonly associated with space heating only applications.

Use of an MCC-91 controller in a residential dwelling will reduce the warranty coverage to that of a commercial warranty application (except when an MCC-91 is used with a Rinnai Hydronic Air Handler).

Limited Warranty

What will Rinnai do?

Rinnai will repair or replace the covered product or any part or component that is defective in materials or workmanship as set forth. Rinnai will pay reasonable labor charges associated with the repair or replacement of any such part or component. All repair parts must be genuine Rinnai parts. All repairs or replacements must be performed by an individual or servicing company that is properly trained, state qualified or licensed to do the type of repair.

Replacement of the product may be authorized by Rinnai only. Rinnai does not authorize any person or company to assume for it any obligation or liability in connection with the replacement of the product. If Rinnai determines that repair of a product is not possible, Rinnai will replace the product with a comparable product at Rinnai's discretion. If a component or product returned to Rinnai is found to be free of defects in material or workmanship, or damaged by improper installation or damaged during return shipping, the warranty claim for product, parts and labor may be denied.

How do I get service?

You must contact a state qualified/licensed contractor or authorized service provider for the repair of a product under this Warranty. For the name of a qualified/authorized service provider please contact your place of purchase, visit the Rinnai website (www.rinnai.us), call Rinnai at 1-800-621-9419 or write to Rinnai at 103 International Drive, Peachtree City, Georgia 30269.

Proof of purchase is required to obtain warranty service. You may show proof of purchase with a dated sales receipt, or by registering within 30 days of purchasing the product. To register your tankless water heater, please visit www.rinnairegistration.com. For those without internet access, please call 1-866-RINNAI1 (746-6241). Receipt of Registration by Rinnai will constitute proof-of-purchase for this product. However, Registration is not necessary in order to validate this Warranty.

What is not covered?

This Warranty does not cover any failures or operating difficulties due to the following:

- accident, abuse, or misuse
- alteration
- misapplication
- force majeure
- improper installation (such as but not limited to inadequate water quality, condensate damage, improper venting, incorrect gas type, incorrect gas or water pressure, or absence of a drain pan under the appliance)
- improper maintenance (such as but not limited to scale build-up, freeze damage, or vent blockage)
- incorrect sizing
- any other causes other than defects in materials or workmanship

This Warranty does not apply to any product whose serial number or manufacture date has been defaced. This Warranty does not cover any product used in an application that uses chemically treated water such as a pool or spa heater. This appliance is suitable for filling large or whirlpool bath tubs with potable water. Refer to the Water Quality Section in the Operation and Installation Manual.

Limitation on warranties

No one is authorized to make any other warranties on behalf of Rinnai America Corporation. Except as expressly provided herein, there are no other warranties, expressed or implied, including, but not limited to warranties of merchantability or fitness for a particular purpose, which extend beyond the description of the warranty herein and further Rinnai shall not be liable for indirect, incidental, special, consequential or other similar damages that may arise, including lost profits, damage to person or property, loss of use, inconvenience, or liability arising from improper installation, service or use. Some states do not allow the exclusion or limitation of incidental or consequential damages, so the above limitation may not apply to you.

Any implied warranties of merchantability and fitness arising under state law are limited in duration to the period of coverage provided by this limited Warranty, unless the period provided by state law is less. Some states do not allow limitations on how long an implied Warranty lasts, so the above limitation may not apply to you.

This Warranty gives you specific legal rights, and you may also have other rights which vary from state to state.

State Regulations

NOTICE BEFORE INSTALLATION

Rinnai direct-vent appliance must be installed by a state qualified or licensed contractor and a properly trained Rinnai Installer. If you are not properly trained, you must not install this unit.

IMPORTANT: In the State of Massachusetts (248 CMR 4.00 & 5.00)

For all side wall horizontally vented gas fueled equipment installed in every dwelling, building or structure used in whole or in part for residential purposes, including those owned or operated by the Commonwealth and where the side wall exhaust vent termination is less than seven (7) feet above finished grade in the area of the venting, including but not limited to decks and porches, the following requirements shall be satisfied:

1. **INSTALLATION OF CARBON MONOXIDE DETECTORS.** At the time of installation of the side wall horizontal vented gas fueled equipment, the installing plumber or gasfitter shall observe that a hard wired carbon monoxide detector with an alarm and battery back-up is installed on the floor level where the gas equipment is to be installed. In addition, the installing plumber or gasfitter shall observe that a battery operated or hard wired carbon monoxide detector with an alarm is installed on each additional level of the dwelling, building or structure served by the side wall horizontal vented gas fueled equipment. It shall be the responsibility of the property owner to secure the services of qualified licensed professionals for the installation of hard wired carbon monoxide detectors
 - a. In the event that the side wall horizontally vented gas fueled equipment is installed in a crawl space or an attic, the hard wired carbon monoxide detector with alarm and battery back-up may be installed on the next adjacent floor level.
 - b. In the event that the requirements of this subdivision can not be met at the time of completion of installation, the owner shall have a period of thirty (30) days to comply with the above requirements; provided, however, that during said thirty (30) day period, a battery operated carbon monoxide detector with an alarm shall be installed.
2. **APPROVED CARBON MONOXIDE DETECTORS.** Each carbon monoxide detector as required in accordance with the above provisions shall comply with NFPA 720 and be ANSI/UL 2034 listed and IAS certified.
3. **SIGNAGE.** A metal or plastic identification plate shall be permanently mounted to the exterior of the building at a minimum height of eight (8) feet above grade directly in line with the exhaust vent terminal for the horizontally vented gas fueled heating appliance or equipment. The sign shall read, in print size no less than one-half (1/2) inch in size, **"GAS VENT DIRECTLY BELOW. KEEP CLEAR OF ALL OBSTRUCTIONS"**.
4. **INSPECTION.** The state or local gas inspector of the side wall horizontally vented gas fueled equipment shall not approve the installation unless, upon inspection, the inspector observes carbon monoxide detectors and signage installed in accordance with the provisions of 248 CMR 5.08(2)(a)1 through 4.

Chauffe-eau d'intérieur sans réservoir à ventilation directe

Manuel d'installation et d'utilisation

RV53i..... REU-VB2020FFU-US

RV53e..... REU-VAM1620W-US

Certifié pour une installation à domicile (mobile) fabriqués.

Enregistrer votre produit à
www.rinnairegistration.com
ou l'appel 1-866-RINNAI1 (746-6241)

INSTALLATEUR : Laissez ce manuel avec l'appareil installé.
CONSOMMATEUR : Conservez ce manuel comme référence ultérieure.

Pour une traduction complète du manuel en français, vous pouvez le télécharger du site Web de www.rinnai.us.

Instructions d'utilisation	
Comportements et pratiques de sécurité	43
Réglage de température	43
Plages de température avec un contrôleur de température	44
Options de température sans contrôleur à distance	44
Entretien	45
Instructions d'installation	
Instructions générales	46
Environnement	47
Écartements par rapport à l'appareil	47
Fixation du chauffe-eau	47
Installation à altitude élevée	48
Tuyauterie de gaz	48
Tuyauterie d'eau	49, 50
Qualité de l'eau	50
Tuyauterie recommandée pour installation de base	51
Instructions de ventilation (RV53i)	
Consignes pour aspiration/évacuation	52
Condensat	52
Longueur maximum de ventilation	53
Produits de ventilation	53
Espacements pour terminaison de cheminée (ANSI Z21.10.3, CSA 4.3)	54
Installation de conduit de cheminée (RV53i)	55
Instructions d'utilisation	56
Diagramme en escalier	57
Support à la clientèle /	
L'information de garantie	58
Garantie limitée	58, 59

AVERTISSEMENT : Assurez-vous de bien suivre les instructions données dans cette notice pour réduire au minimum le risque d'incendie ou d'explosion ou pour éviter tout dommage matériel, toute blessure ou la mort.

- Ne pas entreposer ni utiliser d'essence ou ni d'autres vapeurs ou liquides inflammables à proximité de cet appareil ou de tout autre appareil.
- **QUE FAIRE SI VOUS SENTEZ UNE ODEUR DE GAZ**
 - Ne pas tenter d'allumer d'appareil.
 - Ne touchez à aucun interrupteur ; ne pas vous servir des téléphones se trouvant dans le bâtiment.
 - Appelez immédiatement votre fournisseur de gaz depuis un voisin. Suivez les instructions du fournisseur.
 - Si vous ne pouvez rejoindre le fournisseur, appelez le service des incendies.
- L'installation et l'entretien doivent être assurés par un installateur ou un service d'entretien qualifié ou par le fournisseur de gaz.

Instructions d'utilisation

Comportements et pratiques de sécurité

AVERTISSEMENT

- Gardez la zone autour de l'appareil dégagée et exempte de matériaux combustibles, essence et autres vapeurs et liquides inflammables.
- N'utilisez pas cet appareil s'il a été plongé dans l'eau, même partiellement. Faites inspecter l'appareil par un technicien qualifié et remplacez toute partie du système de contrôle et toute commande qui ont été plongés dans l'eau.
- Cet appareil est équipé d'une prise de trois-fourche pour votre protection contre le risque de choc et devrait être branché directement à un réceptacle correctement fondé de trois-fourche. Ne coupez pas ou n'enlevez pas la fourche moulue de cette prise.
- Toute altération de cet appareil ou de ses commandes peut être dangereuse.
- Vérifiez toujours la température de l'eau avant d'entrer sous la douche ou dans la baignoire.

Réglage de température

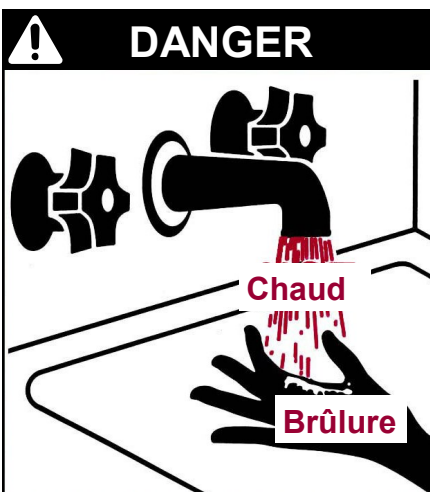

L'eau chaude peut être dangereuse, en particulier pour les enfants, les personnes âgées et les infirmes. Il y a un risque d'échaudage si la consigne du thermostat est réglée trop haut.

Des températures dépassant 125° F (52 °C) peuvent causer de sévères brûlures ou un échaudage, pouvant entraîner la mort.

L'eau chaude peut causer des brûlures au premier degré suite à des expositions aussi limitées que :

3 secondes à 140° F (60 °C)

20 secondes à 130° F (54 °C)

8 minutes à 120° F (49 °C)

Testez la température de l'eau avant de placer un enfant sous la douche ou dans le bain.

Ne laissez pas un enfant ou une personne infirme dans une baignoire sans surveillance.



1. Appuyez sur le bouton de priorité du contrôleur à distance. Le voyant vert de priorité va s'allumer pour montrer que c'est ce contrôleur qui règle la température de consigne et que le chauffe-eau Rinnai est prêt à fournir de l'eau chaude.

La présence d'un contrôleur sur les autres ne peut se modifier que s'il n'y a pas d'eau chaude qui coule.



Temp. d'eau



2. Appuyer sur les boutons ▲ ou ▼ pour obtenir la valeur de température de consigne voulue.

L'eau chaude est fournie à tous les points de distribution à cette température sauf un changement désiré au point d'origine ou à n'importe quelle commande.

AVIS

La température peut être ajustée entre 98° F (37 °C) et 110° F (43 °C) même en cas de tirage d'eau.

AVIS

Vérifiez vos normes locales concernant la température maximale de l'eau permise pour une utilisation dans maisons de soins, écoles, garderies, et pour toutes les autres applications publiques.

AVIS

Si une unité nouvellement installée avec un contrôleur à distance n'a pas été activée pendant au moins 6 heures, alors sa température de consigne reviendra à la valeur par défaut de 104° F (40 °C) s'il y a une interruption du secteur.

AVIS

Il peut y avoir une différence entre la température de consigne affichée sur le contrôleur à distance et la température réelle au robinet, du fait des conditions d'environnement, ou de la longueur de tuyauterie depuis le chauffe-eau.

Plages de température avec un contrôleur de température

Ce chauffe-eau va tenter de fournir de l'eau chaude à température stable malgré les variations de débit ou quand plus d'un robinet est ouvert. La chauffe-eau ne peut délivrer de l'eau qu'à une seule température de consigne à la fois. Les températures de consigne disponibles pour un modèle donné sont fournies ci-dessous :

Model	Arrangements de température disponibles (°F)														
RV53i RV53e	98	100	102	104	106	108	110	115	120	125	130	135	140	150*	160*
Temp in Celsius °C	37	38	39	40	41	42	43	46	49	52	54	57	60	66	71

* MCC-91 Contrôleur de Température Ces cadres exigent le MCC-91 contrôleur. Quand le MCC-91 contrôleur est connecté, ces plus hautes températures sont disponibles sur tous modèles de contrôleur dans le système. L'usage d'un MCC-91 contrôleur dans une demeure résidentielle réduira la couverture de garantie à cela d'une application de garantie commerciale.

Le MCC-91 contrôleur est l'intention eu pour les applications de publicité et hydronic seulement. Si un MCC-91 contrôleur est utilisé dans une demeure résidentielle pour une application de hydronics, une soupape mélangeant doit être aussi installée pour limiter la température d'eau chaude potable à une température sûre. Arroser des températures plus de 125° F (52° C) peut causer des brûlures ou scalding sévère. Se référer à l'Alerte de Danger sur les températures d'eau. Rinnai ne fait pas, en tout cas, être responsable des dommages qui résultent de tel usage impropre ou tel mauvais usage.

Les températures suggérées sont de :

- Cuisine 120° F (49° C)
- Douche 98 - 110 °F (37 - 43 °C)
- Baignoire 102 - 110 °F (39 - 43 °C)

Ces températures ne sont que des suggestions.

Une température inférieure à 98° F (37 °C) peut s'obtenir par ajout d'eau froide avec un robinet mitigeur.

Pour passer l'affichage de température de Celsius à Fahrenheit ou vice versa, actionnez et maintenez enfoncé le bouton M/A pendant 5 secondes avec le chauffe-eau en position d'arrêt.

Options de température sans contrôleur de température

Le réglage de température de consigne par défaut pour cet appareil sans un contrôleur à distance est de 120° F (49 °C). On peut, si on le souhaite, la passer sur 140° F (60 °C) en modifiant la position d'un seul micro-commutateur.

À la banque SW1 de 8 interrupteurs à positions multiples, le micro-commutateur 5 donne un réglage à 120°F (49 °C) s'il est sur OFF (valeur automatique) mais à 140°F (60 °C) s'il est sur ON.

Si un contrôleur de température est installé, alors le contact 5 n'a aucun effet sur des arrangements de température.

AVERTISSEMENT NE touchez PAS aux autres micro-commutateurs sauf s'il vous est spécifiquement demandé de le faire.

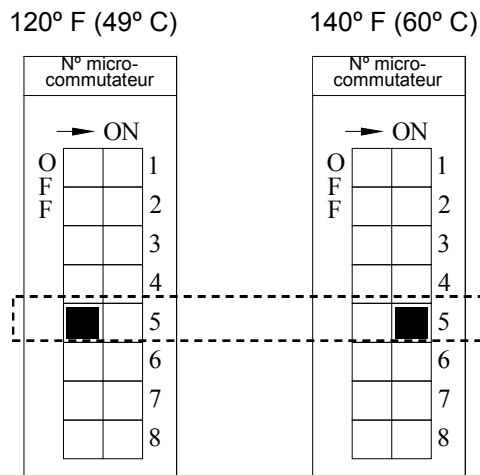

AVERTISSEMENT

Coupez l'alimentation électrique, et fermez l'arrivée de gaz et d'eau à leur vanne de coupure manuelle avant toute intervention sur l'unité.

Les réparations ne doivent être effectuées que par un technicien de service qualifié. Cet appareil doit être inspecté annuellement par un technicien de service qualifié. Vérifiez le bon fonctionnement après chaque intervention.

Nettoyage

Il est impératif de contrôler compartiments, brûleurs et passages pour la circulation de l'air sur l'appareil à nettoyer.

Procédez au nettoyage comme ceci :

1. Coupez et débranchez l'alimentation électrique. Laissez refroidir le chauffe-eau.
2. Fermez l'eau fermer les robinets. Démontez et nettoyez le filtre d'arrivée d'eau.
3. Démontez le panneau frontal en enlevant ses 4 vis.
4. Utilisez de l'air comprimé pour dépeussier brûleur principal, échangeur thermique et pales de ventilateur. N'utilisez pas de chiffon mouillé ou de nettoyants à pulvériser sur le brûleur. N'utilisez pas de substances volatiles comme benzène ou diluants. Ils pourraient s'enflammer ou décolorer la peinture.
5. Utilisez un chiffon doux sec pour essuyer le boîtier.

Système de ventilation

Les conduites de prise d'air et d'évacuation doivent être inspectées au moins tous les ans pour y détecter des blocages ou dommages éventuels.

Moteurs

Les moteurs sont lubrifiés à vie et ne demandent pas de lubrification périodique. Maintenez ventilateur et moteur sans poussière ou saleté en les nettoyant tous les ans.

Contrôleur à distance

Utilisez un chiffon humide pour nettoyer les contrôleurs à distance. N'employez pas de solvants.

Accumulation de calcaire et de tartre

Si vous recevez le code d'erreur « LC », reportez-vous à la procédure de *rinçage de l'échangeur thermique*. Voyez aussi la section sur la *qualité de l'eau* pour savoir si votre eau a besoin d'un traitement ou conditionnement en amont. (Lors de la vérification de l'historique des anomalies pour l'entretien, le code « 00 » aura remplacé « LC ».)

Accumulation de neige

Maintenez la zone autour de la terminaison de cheminée libre de toute neige et glace. Cet appareil ne peut pas bien fonctionner si ses bouches d'aspiration et d'évacuation d'air sont entravées (blocage total ou même partiel) par des obstacles quelconques.

Inspection visuelle de flamme

Le brûleur doit être allumé de façon régulière sur toute sa surface quand il fonctionne correctement. La flamme doit être claire, bleutée et stable. Reportez-vous à la décomposition par pièces du brûleur pour l'emplacement des hublots d'inspection.

La configuration de flamme est illustrée ci-dessous :

CORRECT

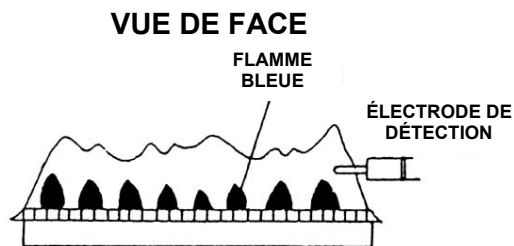

INCORRECT

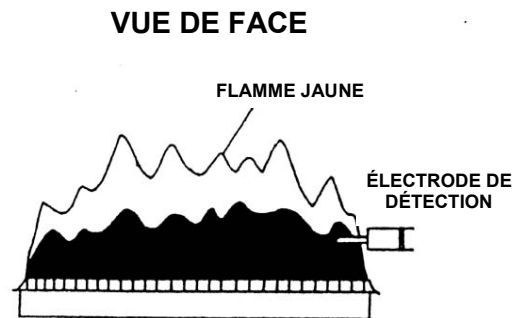

Instructions d'installation

Seuls des installateurs qualifiés avec une formation adéquate peuvent installer cet appareil. La garantie peut être annulée suite à une installation incorrecte ou réalisée par un installateur non qualifié.

Rinnai recommande fortement que les installateurs suivent une classe pour la connaissance des produits. Pour vous informer sur les cours de formation de Rinnai, appelez :
1-800-621-9419.

RV53i REU-VB2020FFU-US
RV53e REU-VAM1620W-US

Certifié pour une installation à domicile (mobile) fabriqués.

Instructions générales



AVERTISSEMENT

N'utilisez pas de matériaux de substitution.

N'utilisez sur cet appareil que des pièces certifiées

- Cet appareil doit être installé par un sous-traitant qualifié ou agréé. Il est de la responsabilité de la personne devant faire installer un chauffe-eau de s'assurer que ce sous-traitant installateur possède les autorisations et permis adéquats pour installer des chauffe-eau dans votre région. Rinnai recommande fortement que les installateurs suivent une classe de connaissance de ses appareils pour assurer la satisfaction du client et la couverture par la garantie. Le non respect de réglementations d'état ou de province relatifs à l'installation de chauffe-eau peut annuler la garantie.
- La RV53i ne doit pas être installé à l'extérieur.
- La RV53e ne doit pas être installé à l'intérieur.
- C'est un installateur ou un technicien de service qualifié qui doit installer, inspecter et vérifier l'absence de fuites de cet appareil avant sa mise en service.
- L'installation doit être en conformité avec les normes locales, et en leur absence avec la *norme américaine sur le gaz combustible, ANSI Z223.1/NFPA 54, ou la norme canadienne sur les installations au gaz naturel et propane, CSA B149.1.*
- Cet appareil doit être installé selon la Manufactured Home Construction and Safety Standard, Title 24 CFR, Part 3280 ou la norme CAN/CSA-Z240 MM M86, Maisons mobiles.
- L'appareil, quand il est installé, doit être électriquement relié à la terre en conformité avec *la norme américaine électrique, ANSI/NFPA 70, ou la norme canadienne électrique, CSA C22.1.*
- L'appareil et sa vanne de gaz doivent être débranchés de la conduite d'alimentation en gaz durant les essais du système en pression dépassant 1/2 psi (3.5 kPa ou 13,84 pouces de hauteur de colonne d'eau).
- L'appareil doit être isolé du système de conduite d'alimentation en gaz en fermant sa vanne individuelle de coupure durant les essais du système en pression inférieurs ou égaux à 1/2 psi (3.5 kPa ou 13,84 pouces de hauteur de colonne d'eau).
- Suivez les instructions d'installation et les conseils de soins et entretien pour avoir de l'air de combustion et de ventilation de façon adéquate.
- L'appareil doit être placé à un endroit où des fuites d'eau venant de l'unité ou des raccordements n'entraîneront pas de dommages dans les environs immédiats de l'appareil ou aux étages inférieurs de la structure. Si un endroit idéal n'est pas disponible, il est recommandé d'installer un bac de récupération bien drainé sous l'appareil. Ce bac ne doit pas freiner le flux de l'air de combustion.
- Le flux d'air de combustion et de ventilation ne doit pas être obstrué.
- Cet appareil ne convient pas pour une utilisation dans une application comme le chauffage d'eau de piscine ou de spa utilisant de l'eau chimiquement traitée (cet appareil peut par contre remplir de grandes baignoires ou bains à tourbillon avec de l'eau potable chaude).
- Si un chauffe-eau est installé dans un système fermé d'alimentation en eau, ayant par exemple un dispositif anti-refoulement dans la conduite d'alimentation en eau froide, il faut fournir les moyens de contrôler l'expansion thermique. Contactez le fournisseur d'eau ou un inspecteur en plomberie local sur la façon de gérer cette situation.
- En cas de surchauffe, ou si la coupure du gaz ne se fait pas, fermez l'arrivée de gaz au niveau de la vanne de contrôle manuelle alimentant l'appareil.
- Gardez la zone d'aspiration d'air exempte de produits chimiques comme chlore ou agent de blanchiment qui produisent des fumées. Ces fumées pourraient endommager des composants et réduire la durée de service de votre appareil.
- Pour la conversion de type de gaz, contactez Rinnai.

Environnement

Air entourant le chauffe eau, l'évacuation et l'évent termination (s) est utilisé pour la combustion et doit être libre de tout composés qui causent la corrosion des composants internes. Ces comprennent des composés corrosifs qui sont trouvés dans les aérosols, les détergents, les agents de blanchiment, les solvants de nettoyage, huile de base peintures et vernis et fluides frigorigènes. L'air de beauté boutiques, magasins de nettoyage à sec, laboratoires de traitement de photos et aires de stockage des fournitures pool contient souvent ces composés. Par conséquent, il est recommandé que les modèles extérieurs soient utilisés pour ces endroits lorsque c'est possible.

Le chauffe-eau, l'évacuation et l'évent termination(s) ne doit pas être installé dans toutes les zones où l'air de combustion peut contenir ces composés corrosifs. Si cela est nécessaire pour un chauffe-eau à être situés dans des zones qui peuvent contenir des composés corrosifs, les instructions suivantes sont fortement recommandées.

CONSIDÉRATIONS IMPORTANTES POUR:

Chauffe-eau d'intérieur

- FAIRE pas les installer dans les zones où air de combustion peut être contaminé par des substances chimiques.

- Avant l'installation, examiner où air a la capacité de voyager dans l'immeuble pour le chauffage de l'eau.

- Lorsque c'est possible, installez le chauffe-eau dans un placard scellé afin qu'elle est protégée contre le potentiel de l'air intérieur contaminé.

- Substances chimiques qui sont corrosifs dans la nature ne doivent pas stockées ou utilisées près de chauffe-eau

Chauffe-eau extérieurs et Évacuation des terminaisons de chauffe-eau internes

- Installez le chauffe-eau aussi loin que possible des hottes de ventilation d'échappement.

- Installez aussi loin que possible des bouches d'air inlet. Fumées corrosives peuvent être libérées par le biais de ces événements lorsque l'air n'est pas apportée grâce à eux.

- Substances chimiques qui sont corrosifs dans la nature ne devraient pas stockées ou utilisées près de la cessation de chauffage ou de vent de l'eau.

Domages et réparation en raison de composés corrosifs dans l'air n'est pas couvert par la garantie.

Écartements par rapport à l'appareil

RV53i	Jusqu'à Com- bustibles	Jusqu'à Non-Com- bustibles
Dessus du chauffe-eau	6 pouces * (152 mm)	2 pouces * (51 mm)
Arrière du chauffe-eau	0 (zero)	0 (zero)
Avant du chauffe-eau	6 pouces (152 mm)	6 pouces (152 mm)
Côtés du chauffe-eau	2 pouces (51 mm)	1/2 pouce (13 mm)
Par rapport au plancher/sol	12 pouces (305 mm)	12 pouces (305 mm)
Ventilation	0 (zero)	0 (zero)

RV53e	Jusqu'à Com- bustibles	Jusqu'à Non-Com- bustibles
Dessus du chauffe-eau	12 pouces (305 mm)	2 pouces (51 mm)
Arrière du chauffe-eau	0 (zero)	0 (zero)
Le devant (le Panneau)	24 pouces (610 mm)	0 (zero)
Le devant (l'Echappement)	24 pouces (610 mm)	24 pouces (610 mm)
Côtés du chauffe-eau	6 pouces (152 mm)	1/8 pouce (3,2 mm)
Par rapport au plancher/sol	12 pouces (305 mm)	2 pouces (51 mm)

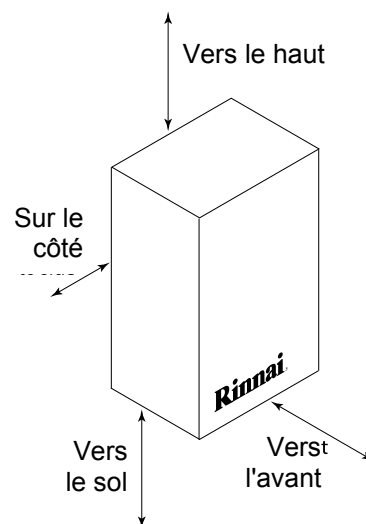

* 0 pouces des composants de ventilation et de la canalisation de vidange condensate.

L'espacement pour des interventions doit faire 24 pouces (610 mm) sur l'avant du chauffe-eau.

Pour V53i installation en placard : espacement de 6 pouces (152 mm) à l'avant.

Fixation du chauffe-eau

- Identifiez l'emplacement d'installation et confirmez que là les espacements requis seront respectés.
- Fixez bien le chauffe-eau au mur en utilisant n'importe lesquels des trous des supports d'installation murale placés en haut et en bas du chauffe-eau. Assurez-vous que la résistance des fixations est suffisante pour supporter le poids de l'appareil. Reportez-vous au poids des modèles de chauffe-eau dans la section des spécifications.

Remarque : Les chauffe-eau de Rinnai doit être installé dans une position verticale. N'installez pas à l'envers ou sur ce côté.

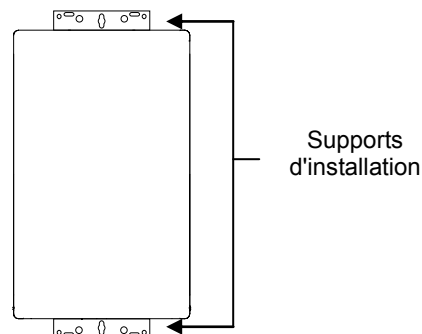

Installation à altitude élevée

Disposez les micro-commutateurs N° 2 et N° 3 sur les positions montrées dans le tableau qui suit en fonction de votre altitude d'installation.

AVERTISSEMENT NE modifiez PAS la disposition des autres micro-commutateurs sauf sur instructions spécifiques.

Micro-commutateur	0-2000 ft (0-610 m)	2001-5200 ft (610-1585 m)	5201-7700 ft (1585-2347 m)	7701-10200 ft (2347-3109 m)
N° 2	OFF	OFF	ON	ON
N° 3	OFF	ON	OFF	ON

N° de micro-commutateur	0-2000 ft (0-610 m)	2001-5200 ft (610-1585 m)	5201-7700 ft (1585-2347 m)	7701-10200 ft (2347-3109 m)
1	ON	ON	ON	ON
2	OFF	OFF	ON	ON
3	OFF	ON	OFF	ON
4	OFF	OFF	OFF	OFF
5	OFF	OFF	OFF	OFF
6	OFF	OFF	OFF	OFF
7	OFF	OFF	OFF	OFF
8	OFF	OFF	OFF	OFF

Pour les installations canadiennes, reportez-vous à la page 34.

Tuyauterie de gaz

Instructions générales

- Une vanne manuelle de coupure de gaz doit être placée sur la conduite d'alimentation en gaz en amont du chauffe-eau Rinnai. Un raccord union peut être utilisé sur la connexion au-dessus de la vanne de coupure pour pouvoir ultérieurement intervenir sur l'unité en la déconnectant.
- Vérifiez le type de gaz d'arrivée et sa pression avant de raccorder le chauffe-eau Rinnai. Si l'appareil a besoin d'un gaz qui n'est pas celui disponible localement, NE branchez PAS le chauffe-eau Rinnai. Contactez votre revendeur pour obtenir le bon modèle correspondant à votre type de gaz.
- Vérifiez la pression du gaz d'alimentation immédiatement en amont à l'arrivée de la régie fournissant le gaz. La pression d'arrivée du gaz doit être dans la fourchette de limites montrée dans la section de spécifications.
- Avant de mettre l'appareil en service, tous les joints, y compris sur le chauffe-eau, doivent avoir leur étanchéité vérifiée, au moyen d'une solution de détection de fuites à l'eau savonneuse, ou une solution ininflammable équivalente éventuellement (comme certaines solutions pour détection de fuites de gaz, incluant l'eau savonneuse, peuvent causer corrosion ou fissuration par contrainte, la tuyauterie doit être rincée avec de l'eau après le test, sauf si vous avez pu déterminer que la solution de détection utilisée n'était pas corrosive).
- Utilisez toujours des connecteurs approuvés pour raccorder l'unité sur la conduite de gaz. Purgez toujours la conduite de gaz de tous débris éventuels avant son branchement sur le chauffe-eau;
- La conduite d'alimentation en gaz doit être étanche au gaz, du bon calibre et installée d'une façon permettant de fournir assez de gaz pour satisfaire la demande maximale du chauffe-eau et de tous les autres appareils fonctionnant au gaz du lieu sans qu'il y ait de chute de pression.
- Tout composé utilisé sur la jonction filetée du tuyau de gaz doit être d'un type qui résiste à l'action du gaz propane ou naturel.
- Reportez-vous à un tableau de calibrage approuvé de tuyauterie de gaz si vous avez un doute sur la taille de votre conduite.

Valve à Bille / Valve de dégagement de pression

Les soupapes d'isolement offrent la possibilité d'isoler le chauffe-eau de la structure plomberie et de permettre un accès rapide à vider l'échangeur de chaleur. Vérifiez auprès des codes locaux pour déterminer si une soupape de pression et de température est nécessaire. Les valves inclus rencontrer American National Standard (ANSI Z21.10.3)-norme canadienne (ASC 4.3) et sont ANSI/NSF 65 approuvé pour l'eau potable.

Valve à Bille Eau Chaude	107000081
Valve à Bille Eau Froide	107000083
RV53i Valve de dégagement de pression (VDP)	107000085
RV53e Valve de dégagement de pression (VDP)	107000086

Instructions d'Installation:

1. Enveloppez les bouts filetés des prises d'eau et sorties d'eau du chauffe-eau sans réservoir, ainsi que le bout fileté de la valve de détente approuvée avec un minimum de 5 enrobages de bande Teflon®.
2. Vissez la valve de dégagement de pression dans les bouts filetés 3/4" à l'opposé du levier pour clapet de retenue sur la valve de service à eau CHAUDE. (Lever de drainage ROUGE).
3. Desserrez l'écrou union de 3/4" sur la valve à eau CHAUDE et raccordez le à la sortie d'eau CHAUDE sur le chauffe-eau sans réservoir. Si l'écrou est enlevé, assurez-vous de réaligner l'about correctement avec la valve et que la rondelle noire soit positionnée de façon à ce que le l'arête de métal de la valve soit à l'intérieur de la rondelle.
4. Alignez la direction du purgeur d'eau CHAUDE à la position désirée.
5. Resserrez l'assemblage union de la valve à eau CHAUDE en utilisant approximativement 15 pied- livres de torsion.
6. Répétez les étapes 3-5 pour la valve à eau FROIDE. (Lever de drainage BLEU) pour la connexion de la prise d'eau FROIDE sur le chauffe-eau sans réservoir.
7. Raccordez l'ENTRÉE de la valve à eau FROIDE à la source d'alimentation en eau PRINCIPALE.
8. Raccordez la SORTIE de la valve à eau CHAUDE à l'EAU CHAUDE du système de plomberie.
9. Assurez-vous que les deux leviers de drainage soient en position fermée, (perpendiculaires à la portion drainage du corps).

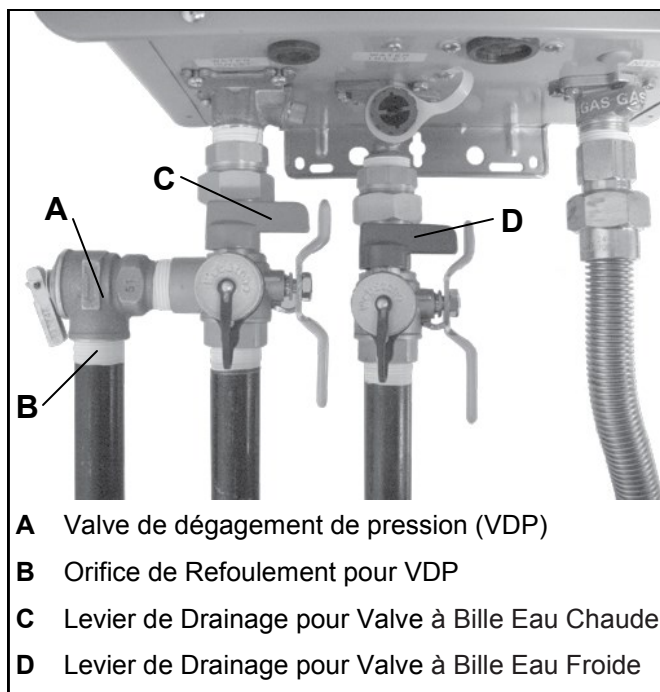

Valve de dégagement de pression Instructions d'Installation:

La VDP doit être raccordée par la connexion filetée opposée à la valve pour clapet de retenue sur la valve d'eau chaude (désignée par le levier de drainage ROUGE) ou par la connexion filetée du côté de l'accessoire de relocalisation au dessus de la valve à eau chaude. L'installation doit maintenir un diamètre de passage de 3/4" sans aucune valve de sectionnement ou restriction de ligne entre l'appareil et la VDP. La conduite de refoulement depuis la VDP devrait être en pente descendante et se terminer à 6" au dessus des drains où le refoulement sera visible. Le bout de refoulement de la ligne devrait être non-fileté et avoir un diamètre minimum de 3/4". La matériel de la ligne de refoulement doit être adapté pour une température d'eau de 180° Fahrenheit et ne doit pas dépasser 30 pieds de longueur ni contenir plus de 4 coudes ou flexions transversales. Aucune valve d'aucune sorte ne doit être installée dans la ligne de refoulement de la valve de dégagement de pression.

Instructions d'Entretien pour la VDP :

Pour un entretien adéquat de cette valve de dégagement de pression, nous recommandons l'opération de la valve en position manuelle, une fois l'an. En ce faisant, il sera nécessaire de prendre toutes les précautions quant à l'écoulement potentiel d'eau bouillante sous pression. Assurez-vous que l'écoulement soit dirigé dans un endroit prédéterminé. Tout contact avec le corps ou autres objets peut causer des dommages ou des blessures. Prière de noter que le VDP inclus dans cet emballage est certifié par CSA International en tant qu'item approuvé.

Tuyauterie d'eau

Instructions générales

- Une vanne manuelle de coupure d'eau doit être intercalée sur la conduite en amont sur l'arrivée d'eau au chauffe-eau Rinnai. Des raccords union peuvent s'utiliser sur les conduites d'eau froide et d'eau chaude pour faciliter les interventions ultérieures avec déconnexion de l'unité.
- La tuyauterie (incluant les matériaux de soudage) et les composants connectés à cet appareil doivent être approuvés pour une utilisation sur des systèmes à eau potable.
- Purgez la conduite d'eau pour en éliminer les débris et l'air. Des débris entrant dans le chauffe-eau Rinnai pourraient l'endommager.
- Des produits chimiques toxiques, comme ceux utilisés pour le traitement d'eau de chaudière, ne doivent pas être utilisés dans l'eau potable utilisée pour le chauffage des locaux.
- Si l'appareil doit être utilisé comme source d'eau potable, il ne doit pas être connecté à un appareil utilisé auparavant comme chauffage et fourniture d'eau non potable.
- Le filtre d'eau du chauffage Rinnai doit être propre et installé.

Soupape de sûreté

- Une soupape de sûreté est nécessaire, d'un type approuvé par les *normes américaines (ANSI Z21.10.3) et canadiennes (CSA 4.3)* pour tous les systèmes de chauffage par eau.
- La soupape de sûreté doit être compatible avec les *normes ANSI Z21.22 (soupapes de sûreté et dispositifs de coupure automatique de gaz pour systèmes de fourniture d'eau chaude) et/ou CAN1-4.4 (soupapes de sûreté combinées à pression et à température et soupapes casse-vide)*.
- La soupape de sûreté doit être homologuée pour 150 PSI (1034 kPa) et au moins la valeur maximum de BTU/H de l'appareil.
- Le déversement venant de la soupape de sûreté doit être amené par tuyau au sol ou dans un système de drainage pour éviter une exposition avec possibilité de brûlure pour humains, végétaux ou animaux. Conformez-vous aux normes locales. L'eau chaude sortant de la soupape de sûreté peut causer des brûlures sévères et des échaudages pouvant même provoquer la mort.
- La soupape de sûreté doit être actionnée manuellement au moins une fois par an pour vérifier qu'elle est toujours fonctionnelle.
- La soupape de sûreté doit être insérée dans la conduite de sortie d'eau chaude en suivant les instructions du fabricant. N'intercalez PAS n'importe quel autre type de vanne ou dispositif de coupure entre la soupape de sûreté et le chauffe-eau.
- Ne bouchez pas la soupape de sûreté, et n'installez aucun raccord réducteur ou autre restriction dans la conduite de déversement. Elle doit permettre un drainage complet de la soupape et de la conduite.
- Si une soupape de sûreté déverse périodiquement, cela peut venir d'une expansion thermique dans un système d'eau fermé. Contactez votre fournisseur d'eau ou votre inspecteur de plomberie local pour voir comment régler cette situation. Mais ne bouchez pas la soupape.
- Ni Rinnai ni la norme nationale américaine (*ANSI Z21.10.3*) ou canadienne (*CSA 4.3*) n'exigent d'utiliser une soupape de sûreté combinée à pression et à température pour cet appareil. Cependant des normes locales peuvent le demander.

Qualité de l'eau

Parmi les soins à apporter à votre chauffe-eau il y a l'évaluation de la qualité de l'eau consommée. Si les paramètres de votre eau dépassent les limites fournies dans ce tableau, il vous faudra traiter ou conditionner cette eau.

* Source : Part 143 National Secondary Drinking Water Regulations (normes américaines sur les réseaux d'alimentation secondaires en eau potable)

	Niveau maximum
Dureté totale	Jusqu'à 200 mg/L
Aluminium*	Jusqu'à 0,2 mg/L
Chlorures*	Jusqu'à 250 mg/L
Cuivre*	Jusqu'à 1,0 mg/L
Fer*	Jusqu'à 0,3 mg/L
Manganèse*	Jusqu'à 0,05 mg/L
pH *	6,5 à 8,5
Matières dissoutes totales (MDT)*	Jusqu'à 500 mg/L
Zinc *	Jusqu'à 5 mg/L

Tuyauterie recommandée pour installation de base

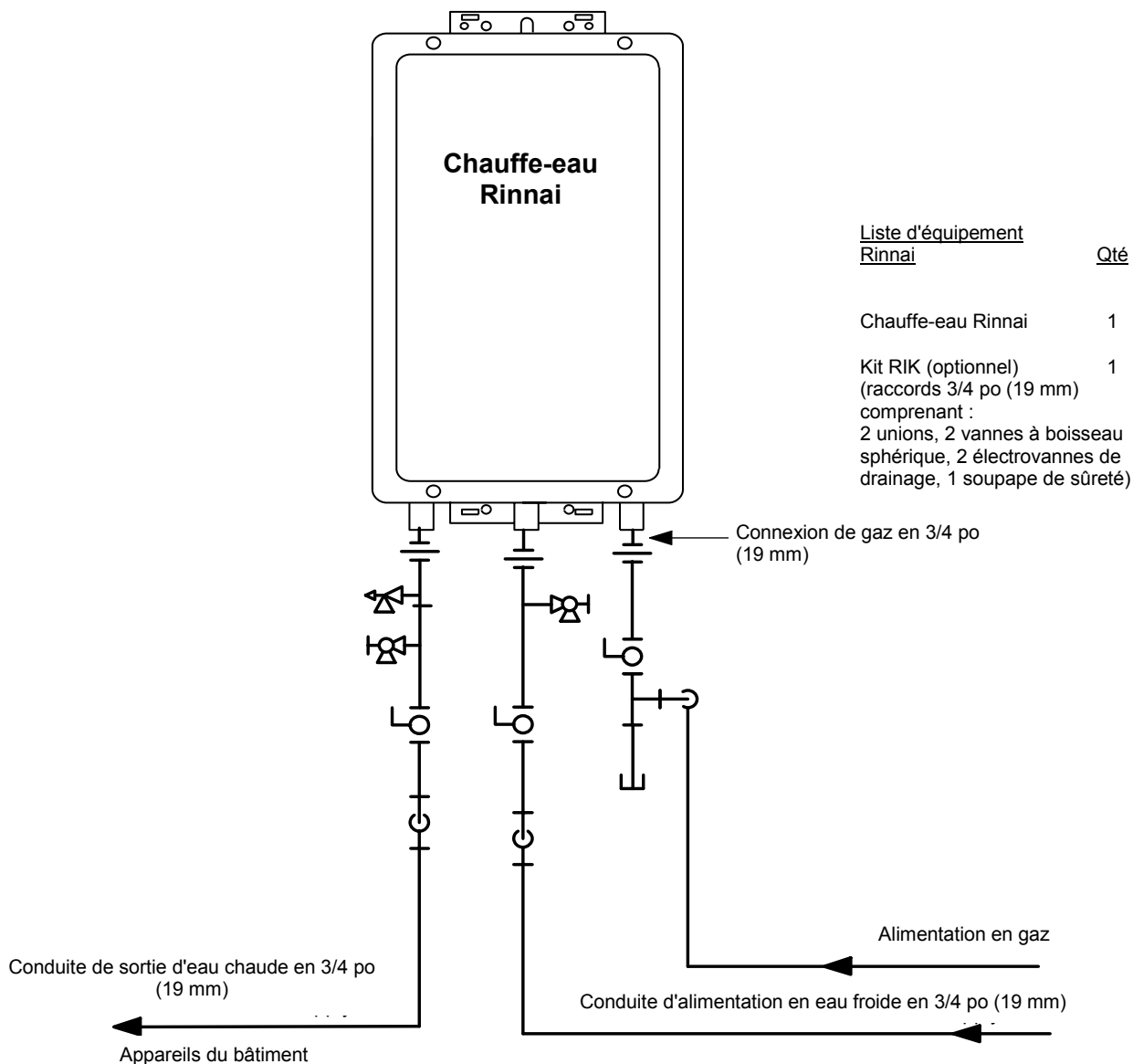

Liste d'équipement Rinnai	
	Qté
Chauffe-eau Rinnai	1
Kit RIK (optionnel) (raccords 3/4 po (19 mm) comprenant : 2 unions, 2 vannes à boisseau sphérique, 2 électrovannes de drainage, 1 soupape de sûreté)	1

Légende		Ceci n'est pas un schéma technique, son but n'est que de vous guider, et il ne tient pas lieu de dessin industriel professionnel pour un projet. Ce schéma n'a pas l'ambition de décrire un système au complet. C'est la responsabilité du concepteur ou de l'ingénieur de déterminer les composants nécessaires et la configuration pour le système spécifique à installer. Ce schéma n'implique aucune conformité avec les exigences des normes de construction locales. C'est la responsabilité du concepteur ou de l'ingénieur de s'assurer que l'installation sera en conformité avec toutes les normes locales de construction applicables. Consultez les autorités compétentes dans ce domaine avant l'installation.
Vanne à tournant sphérique 3/4 po (19 mm) Raccord union 3/4 po (19 mm) Clapet anti-retour Soupape de décharge	Régulateur de pression Pompe de circulation Vanne de purge de chaudière Électrovanne	

Instructions de ventilation (RV53i)

Consignes pour aspiration/évacuation **Référez-vous aux instructions spécifiques sur votre produit de ventilation pour les exigences supplémentaires d'installation.**

- Ce chauffe-eau est un modèle à ventilation directe, et de ce fait est certifié et listé avec son système de ventilation. Vous devez utiliser des composants de ventilation qui sont certifiés et listés avec le modèle de chauffe-eau. Ne combinez pas de composants de ventilation venant de constructeurs différents.
- Le système de ventilation doit vent directement à l'extérieur du bâtiment et d'utiliser l'air extérieur à la combustion.
- Le système doit ventiler directement vers l'extérieur du bâtiment et utiliser de l'air extérieur pour la combustion.
- La ventilation doit être aussi directe que possible avec un minimum de raccords de tuyauterie.
- Évitez les abaissements et fléchissements sur les tronçons de ventilation horizontaux en installant des supports en suivant les installations du fabricant de la ventilation.
- Supportez les tronçons de ventilation horizontaux tous les 4' (1,2 m) et les tronçons verticaux tous les 6' (1,8 m), ou en conformité avec les normes locales.
- Le diamètre de ventilation ne doit pas comporter de réductions.
- Ne connectez pas le système de ventilation sur une ventilation ou une cheminée existante.
- Ne partagez pas la ventilation avec le tuyau de ventilation de tout autre chauffe-eau ou appareillage.
- Les connexions de ventilation doivent être fermement pressées ensemble de façon à ce que leurs jonctions forment une bonne étanchéité à l'air.
- La pièce de ventilation connectée sur le chauffe-eau doit être fixée avec une vis autotaraudeuse.
- Reportez-vous aux instructions du constructeur de la ventilation pour les instructions d'assemblage des différents éléments.
- Si le circuit de mise à l'air libre doit être enfermé, on le suggère que la conception de la clôture permette l'inspection du circuit de mise à l'air libre. La conception d'une telle clôture sera considérée acceptable par l'installateur ou l'inspecteur local.

AVIS

S'il devient nécessaire d'accéder à un circuit de mise à l'air libre inclus pour le service ou les réparations, Rinnai n'est pas responsable d'aucuns coûts ou difficulté en accédant au circuit de mise à l'air libre. La garantie ne couvre pas obtenir l'accès à un circuit de mise à l'air libre inclus.

Condensat

La formation de condensat peut arriver même sur les appareils à ventilation directe de haute performance. Pour éviter que le condensat n'endommage, suivez ces instructions.

- Les terminaisons verticales doivent incorporer un drainage de condensat et un piège aussi près que possible de l'appareil.
- Le chauffage de l'eau RV53i a un collecteur de condensat intégré.
- Rinnai offre un piège de condensats.
- Dans les régions à climat froid il se produira plus de condensat dans le système de ventilation. Un collecteur de condensat est recommandé pour ces climats.
- Utiliser uniquement le vent qui est approuvé et identifié comme acceptable pour votre modèle particulier.
- N'utilisez pas de vent cette appliance en PVC, CPVC, ABS ou matériau galvanisé.
- Pente la ventilation vers l'apppliance selon les instructions d'installation du fabricant évent.
- Rejetez le condensat en respectant les normes locales.
- Utiliser uniquement des tuyaux en PVC ou CPVC pour la ligne de cerveaux de condensats.
- Le tuyau de cerveaux condensat doit être aussi courte que possible et ont une hauteur de ton vers le bas.
- Ne branchez pas le tuyau de cerveaux condensat directement à l'égout de pluie.



AVERTISSEMENT

Si un collecteur de condensat n'est pas utilisé, le tuyau de drainage doit être capuchonné pour éviter que gaz d'échappement et condensat n'entrent dans le bâtiment. Ce capuchon est livré sur l'appareil.

AVIS

Des dispositions doivent être prises pour éviter que du condensat n'entre dans le chauffe-eau. Sans un drainage adéquat et un rejet, le condensat peut endommager l'échangeur thermique.

- Le tuyau de cerveaux condensat (sur toute sa longueur) doit être au moins le même diamètre que la ligne de cerveaux.
- La fin de la conduite de cerveaux condensat doit être ouverte à l'atmosphère. La fin ne devrait pas être sous l'eau ou d'autres substances.
- Ne branchez pas la ligne de cerveaux condensat avec une climatisation Evaporateur bobine des cerveaux.
- Pour minimiser la congélation du condensat, exécutez la ligne de cerveaux de condensat à travers un mur intérieur ou entre l'isolation et un mur intérieur.
- Le collecteur de condensat devrait être utilisé pour toutes les applications de chauffage hydronic.

Instructions de ventilation (RV53i)

Longueur maximum de ventilation

- Déterminez le nombre de coudes à 90° dans le système de ventilation (deux coudes à 45° comptent pour un coude à 90°).
- Référez-vous au tableau pour trouver la longueur de ventilation maximum sur la base du nombre de coudes.
- Suivez les recommandations de la note applicable.

Exemple : Si vous n'avez qu'un coude votre longueur de ventilation maximum est alors de 35 pieds (10.7 m). Si votre longueur effective fait plus de 15 pieds (4.6 m) vous devez passer le microcommutateur N° 1 (SW1) en position OFF.

Nombre de coudes à 90°						
0	1	2	3	4	5	6
41 ft ① (12.5 m)	35 ft ② (10.7 m)	29 ft ③ (8.8 m)	23 ft ④ (7.0 m)	17 ft ④ (5.2 m)	11 ft ④ (3.4 m)	5 ft ④ (1.5 m)

- Si la longueur fait plus de 21' (6.4 m) passez le microcommutateur N° 1 (SW1) en position OFF.
- Si la longueur fait plus de 15' (4.6 m) passez le microcommutateur N° 1 (SW1) en position OFF.
- Si la longueur fait plus de 9' (2.7 m) passez le microcommutateur N° 1 (SW1) en position OFF.
- Passez le microcommutateur N° 1 (SW1) en position OFF.

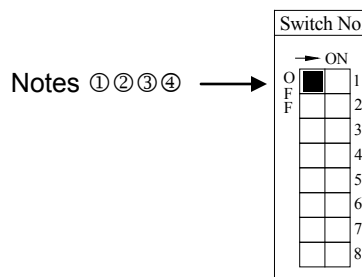

AVIS

Si vous avez une longueur de ventilation plus grande, le microcommutateur N° 1 doit être mis en position OFF. Cela assure que le chauffe-eau fonctionne correctement. Des codes d'erreur de conduit de cheminée obstruée et des coupures peuvent arriver si ce microcommutateur N° 1 n'est pas en position correcte.

Produits de ventilation

Produits de ventilation listés et testés pour *RV53i* (*REU-VB2020FFU-US*)

Constructeur	Produit	Pièces
Rinnai/Ubbink	Système de ventilation Rolux	Reportez-vous aux documents techniques du constructeur pour les numéros de pièces spécifiques et les instructions.
Heat-Fab	Système de ventilation SC Saf-T	
Metal-Fab	Système de ventilation/admission d'air Com/Guard	

Contacts avec les constructeurs de ventilation pour des informations d'installation et de liste de pièces :

Rinnai/Ubbink

Téléphone : 800-621-9419
Fax : 678-829-1666
Site Web : www.rinnai.us

Heat-Fab

Téléphone : 800-772-0739
Fax : 413-863-4803
Courriel : custsvc@heat-fab.com
Site Web : www.heatfab.com

Metal-Fab Inc.

Téléphone : 800-835-2830
316-943-2351
Fax : 316-943-2717
Courriel : info@mtlfab.com
Site Web : www.metal-fabinc.com

E spacements pour terminaison de cheminée (ANS Z21.10.3, CSA 4.3)

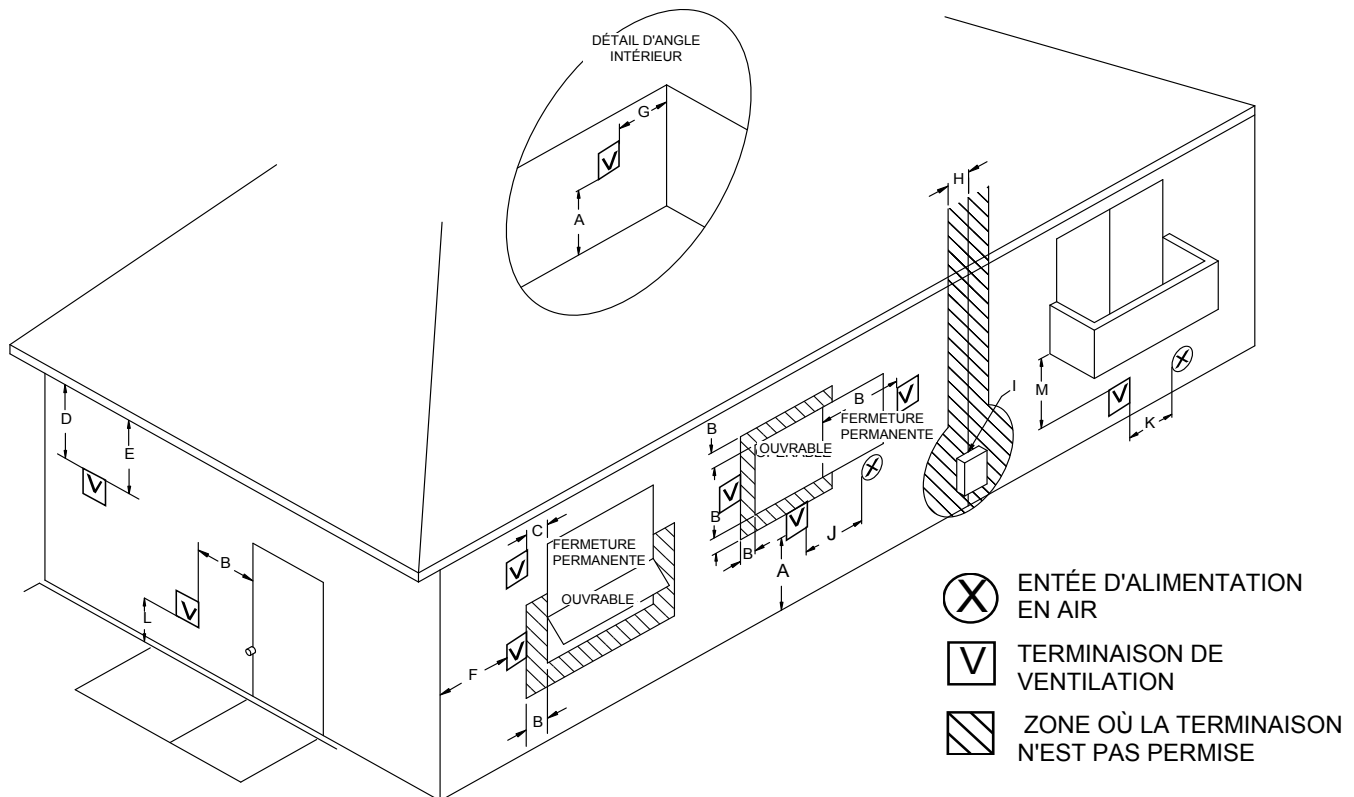

Réf.	Description	Installations au Canada	Installations aux USA
A	Espace au dessus de niveau du sol, véranda, porche, plate-forme ou balcon	12" (30 cm)	12" (30 cm)
B	Écartement par rapport à fenêtre ou porte qui peut s'ouvrir	36" (91 cm)	12" (30 cm)
C	Écartement par rapport à fenêtre toujours fermée	*	*
D	Espacement vertical par rapport à combles ventilés, situés au-dessus de la terminaison à une distance horizontale de 2' (61 cm) de la ligne centrale de terminaison	*	*
E	Espacement vertical par rapport à combles non ventilés	*	*
F	Écartement par rapport à un angle extérieur	*	*
G	Écartement par rapport à un angle intérieur	*	*
H	Espacement par rapport à chaque côté d'une ligne centrale prolongée au-dessus de l'ensemble de compteur/régulateur	3 pieds (91 cm) avec une hauteur de 15 pieds (4,5 m) au-dessus de l'ensemble de régulation	*
I	Écartement par rapport à la sortie de ventilation du régulateur de service	36" (91 cm)	*
J	Écartement par rapport à entrée d'alimentation d'air non mécanique dans le bâtiment ou entrée d'air de combustion vers tout autre appareil	36" (91 cm)	12" (30 cm)
K	Écartement par rapport à entrée d'alimentation d'air mécanique	6' (1,83 m)	3' (91 cm) au dessus si à 10' (3 m) horizontalement
L	Espacement au dessus d'un trottoir ou passage pavé situé dans le domaine public	7' (2,13 m) ①	*
M	Espacement sous véranda, porche, plate-forme ou balcon	12" (30 cm) ②	*

- ① Une ventilation ne doit pas se terminer directement au-dessus d'un trottoir ou passage pavé situé entre deux habitations familiales et les desservant toutes les deux.
- ② Permis uniquement si véranda, porche, plate-forme ou balcon est entièrement ouvert au moins sur deux côtés en dessous du plancher.
- * Pour les espacements non spécifiés dans ANSI Z223.1/NFPA 54 ou CSA B149.1, il faut appliquer les valeurs conformes aux normes locales d'installation et aux exigences du fournisseur de gaz.
L'espacement par rapport au mur opposé est de 24" (60 cm) pour Canada et USA.

Horizontal Termination without using the Condensate Collector

⚠ AVERTISSEMENT

Si un collecteur de condensat n'est pas utilisé, le tuyau de drainage doit être capuchonné pour éviter que gaz d'échappement et condensat n'entrent dans le bâtiment. Ce capuchon est livré sur l'appareil.

* Un collecteur de condensat est requis sur les terminaisons horizontales si une élévation verticale dans le système de ventilation dépasse 5' (1.52 m).

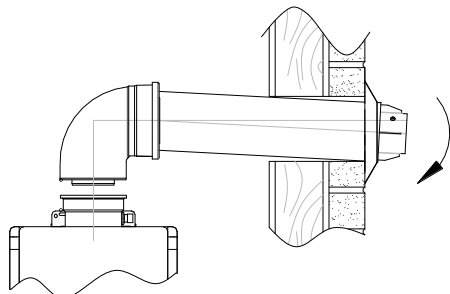

Hauteur maximum *
5' (1.52 m)

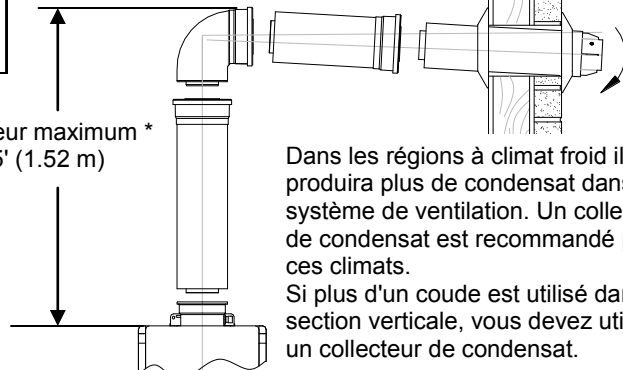

Dans les régions à climat froid il se produira plus de condensat dans le système de ventilation. Un collecteur de condensat est recommandé pour ces climats.

Si plus d'un coude est utilisé dans la section verticale, vous devez utiliser un collecteur de condensat.

Terminaison horizontale avec collecteur de condensat

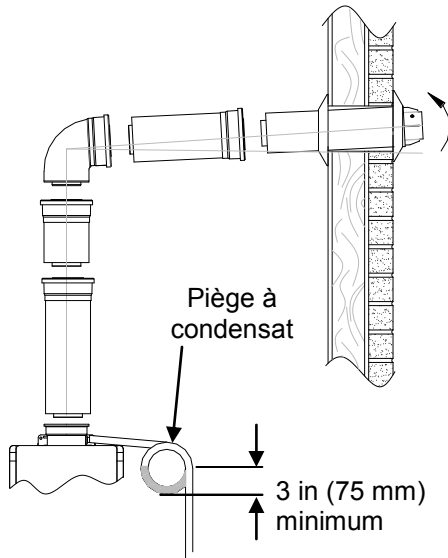

Terminaison verticale (collecteur de condensat requis pour toutes les installations)

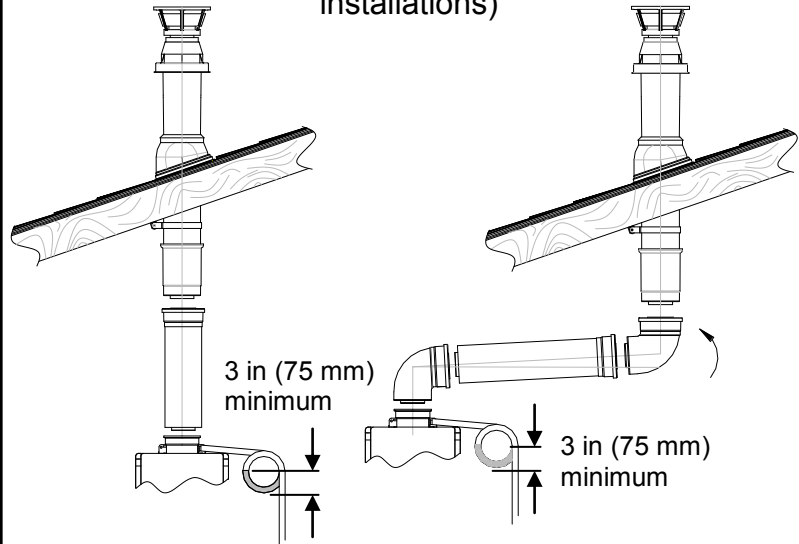

Collecteur de condensat

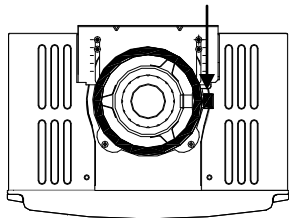

Support

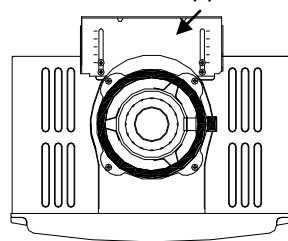

Pour régler la position du collecteur de condensat, ou remplacer le haut de ventilation femelle par un male :

1. Desserrez les 4 vis du support arrière.
2. Faites glisser le support du haut de ventilation femelle.
3. Enlevez les 4 vis fixant le haut de ventilation femelle sur le chauffe-eau.
4. Levez le haut de ventilation femelle et repositionnez-le comme souhaité (ou remplacez-le par un haut de ventilation male).
5. Remettez les 4 vis du haut de ventilation et resserrez les 4 vis du support.

Vis de fixation

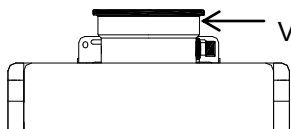



Fixez la pièce de ventilation connectée sur le chauffe-eau avec une vis autotaraudeuse dans le trou situé au dessus du collecteur de condensat.

À LIRE AVANT LA MISE EN SERVICE POUR VOTRE SÉCURITÉ

AVERTISSEMENT Si vous ne suivez pas exactement ces instructions, il peut en résulter un départ d'incendie ou une explosion, causant dégâts

- A. Cet appareil ne comporte pas de veilleuse. Il est muni d'un dispositif d'allumage qui allume automatiquement le brûleur. Ne tentez pas d'allumer la veilleuse manuellement.
- B. AVANT DE FAIRE FONCTIONNER, reniflez tout autour de l'appareil pour déceler une odeur de gaz. Reniflez près du plancher, car certains gaz sont plus lourds que l'air et peuvent s'accumuler au niveau du sol.
- QUE FAIRE SI VOUS SENTEZ UNE ODEUR DE GAZ :
- Ne pas tenter d'allumer d'appareil.
 - Ne touchez à aucun interrupteur ; ne pas vous servir des téléphones se trouvant dans le bâtiment.
 - Appelez immédiatement votre fournisseur de gaz depuis un voisin. Suivez les instructions du fournisseur.
- Si vous ne pouvez rejoindre le fournisseur, appelez le service des incendies.
- C. Ne poussez ou tournez la manette d'admission du gaz qu'à la main ; ne jamais utiliser d'outil. Si la manette reste coincée, ne pas tenter de la réparer ; appelez un technicien qualifié. Le fait de forcer la manette ou de la réparer peut déclencher une explosion ou un incendie.
- D. N'utilisez pas cet appareil s'il a été plongé dans l'eau, même partiellement. Faites inspecter l'appareil par un technicien qualifié et remplacez toute partie du système de contrôle et toute commande qui ont été plongés dans l'eau.

INSTRUCTIONS DE MISE EN MARCHÉ

1. ARRÊTEZ ! Lisez les instructions de sécurité sur la portion supérieure (à gauche) de cette étiquette.
2. Réglez le thermostat sur la consigne la plus basse.
3. Coupez l'alimentation électrique de l'appareil en utilisant son bouton M/A.
4. L'appareil est équipé d'un dispositif d'allumage qui allume automatiquement le brûleur. Ne tentez pas d'allumer la veilleuse manuellement.
5. Repérez la vanne de gaz manuelle sur le côté du chauffe-eau. Fermez-la en la tournant à fond dans le sens horaire (position OFF). 
6. Attendez cinq (5) minutes pour laisser échapper tout le gaz. Reniflez tout autour de l'appareil, y compris près du plancher, pour déceler une odeur de gaz. Si vous sentez une odeur de gaz, ARRÊTEZ ! Passez à l'étape B des instructions de sécurité sur la portion supérieure (à gauche) de cette étiquette. S'il n'y a pas d'odeur de gaz, passez à l'étape suivante.
7. Ouvrez l'arrivée de gaz en tournant la vanne manuelle de gaz en sens antihoraire (position ON). 
8. Rétablissez l'alimentation électrique de l'appareil avec son bouton M/A.
9. Passez le thermostat sur le réglage de consigne souhaité.
10. Ouvrez un robinet d'eau chaude du circuit. Si l'appareil ne démarre pas, suivez les instructions ci-dessous relatives à la coupure du gaz vers l'appareil et appelez un technicien de service ou votre fournisseur de gaz.

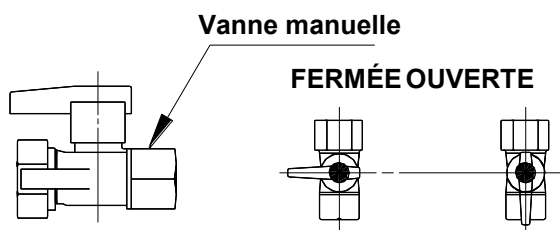

COMMENT COUPER L'ADMISSION DE GAZ DE L'APPAREIL

1. Coupez l'alimentation électrique de l'appareil en utilisant son bouton M/A.
2. Réglez le thermostat sur la consigne la plus basse.
3. Repérez la vanne de gaz manuelle sur le côté du chauffe-eau. Fermez-la en la tournant à fond dans le sens horaire (position OFF). 

RV53i

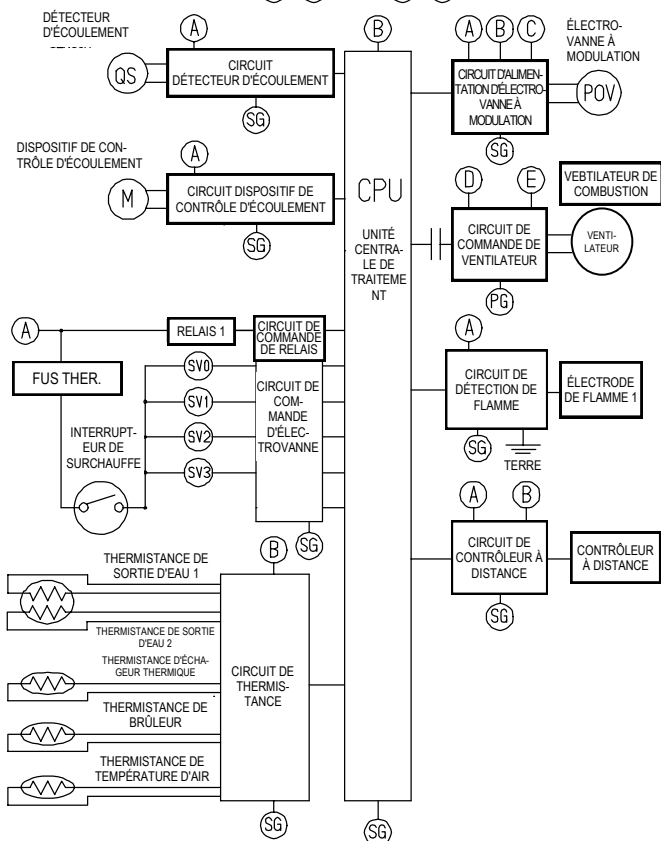
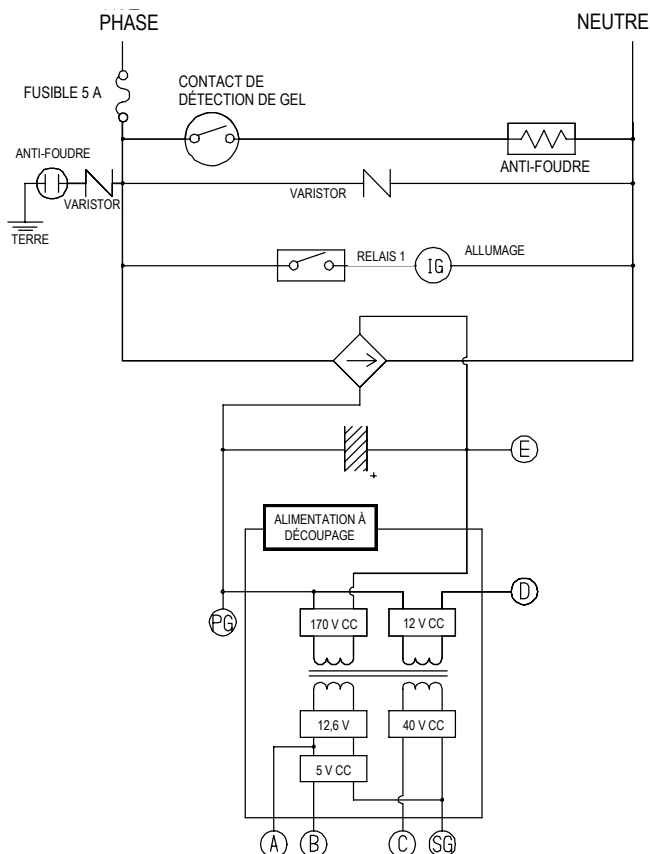

RV53e

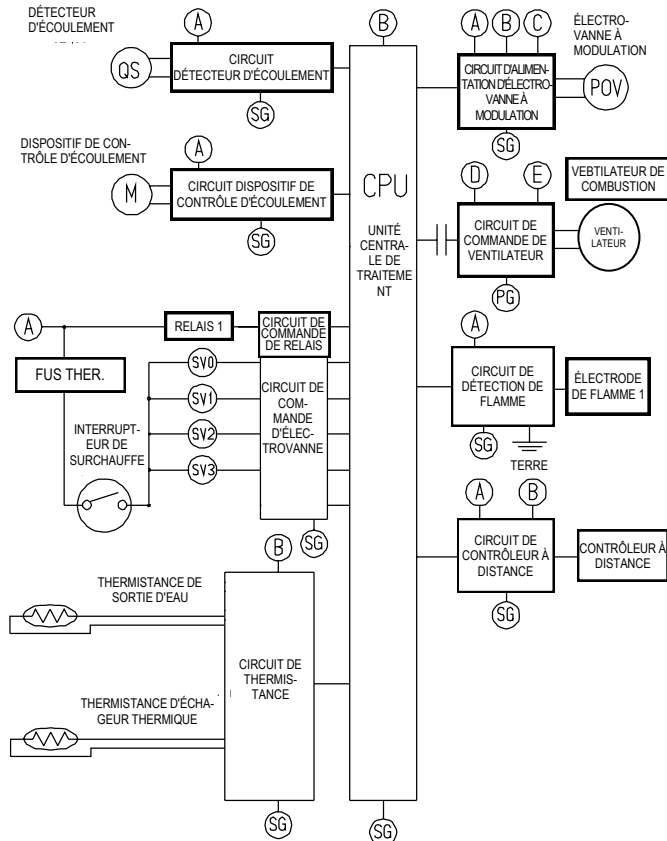
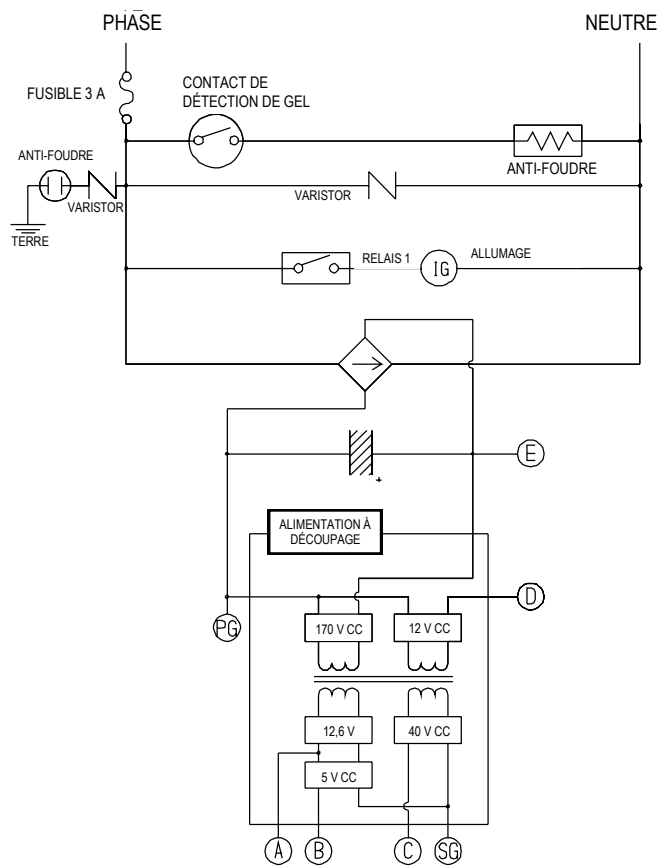

Support à la clientèle

L'information de garantie

Le programme d'installation est responsable de l'installation correcte de votre chauffe-eau.

Veuillez compléter les informations ci-dessous pour conserver pour vos enregistrements:

Référence de modèle _____ Numéro de série _____

Appareil acheté chez _____

Adresse _____

Téléphone _____ Date de l'achat _____

Installé par _____ N° d'immatriculation de l'installateur _____

Adresse _____ Téléphone _____

Date de l'installation _____

Garantie limitée

Qu'est-ce qui est couvert ?

Cette garantie couvre tous défauts dus aux matériaux et à la main d'œuvre quand le produit a été installé et utilisé en suivant les instructions écrites d'installation de Rinnai, dans les termes décrits dans ce document de garantie limitée. Cette garantie s'applique seulement aux produits qui sont installés correctement. Une installation incorrecte pourrait annuler cette garantie. Rinnai vous recommande fortement d'employer un installateur qui aura suivi une classe Rinnai pour la connaissance des produits avant d'installer le chauffe-eau. Cette garantie couvre l'acheteur d'origine uniquement tant que le produit reste sur le site de son installation initiale. Cette garantie ne joue qu'après la toute première installation du produit et se termine s'il est déplacé ou réinstallé à un autre emplacement.

Combien de temps dure la couverture ?

Élément	RV53i and RV53e Période de couverture (à partir de la date d'achat)		
	Applications domestiques Avec traitement d'air Rinnai pour chauffage et eau domestiques	Utilisée pour le chauffage radiant avec autres que le gestionnaire d'air Rinnai	Applications commerciales
Échangeur thermique	10 ans *	3 ans	Non couverture
Autre pièces et composants	5 ans *	3 ans	
Main d'œuvre dans la limite du raisonnable	1 an	1 an	

* Note : La période de couverture est réduite à 3 ans à partir de la date d'achat quand le chauffe-eau est utilisé comme chauffage d'eau circulante dans une boucle de circulation d'eau chaude, où il est utilisé en série avec un système de circulation, et que toute l'eau qui circule passe au travers de lui, et où un système de recirculation à la demande n'est pas incorporé.

Une recirculation à la demande est définie comme une boucle de recirculation d'eau chaude ou un système qui utilise des conduites d'eau chaude et froide existantes, ou une conduite de retour dédiée, et qui ne s'active que lorsque de l'eau chaude est utilisée. L'activation peut se faire par bouton poussoir, détecteur de mouvement ou activation vocale, mais pas par un capteur de température. Une minuterie ajoutée sur une pompe de recirculation standard n'est pas considérée comme donnant un système à la demande.

Il n'y a aucune garantie sur les produits installés dans une application de boucle fermée, couramment associée aux seules applications de chauffage.

L'utilisation d'un contrôleur MCC-91 dans une habitation résidentielle réduira la couverture de garantie au niveau de la garantie pour une application commerciale

Garantie limitée

Que fait Rinnai pour exercer la garantie ?

Rinnai va réparer ou remplacer le produit, ou toute partie ou tout composant défectueux pour cause de matériaux ou de main d'œuvre, dans les conditions définies plus loin. Rinnai remboursera des charges de main d'œuvre raisonnables associées avec la réparation ou le remplacement de toute pièce ou tout composant. Toutes les pièces utilisées pour la réparation doivent être des pièces Rinnai d'origine. Toutes les réparations et tous les remplacement doivent être effectués par un artisan ou du personnel de société de service qui aura été convenablement formé et sera administrativement agréé pour effectuer ce type de travail.

Le remplacement du produit complet ne peut être autorisé que par Rinnai. Rinnai n'autorise aucune personne ou entité à assumer pour elle toute obligation ou responsabilité en relation avec le remplacement du produit. Si Rinnai détermine que la réparation d'un produit n'est pas possible, Rinnai le remplacera par un produit comparable, à sa discrétion. Si un composant ou un produit retourné à Rinnai est trouvé sans défaut du aux matériaux ou à la main d'œuvre, ou qu'il est déterminé qu'il a été mal installé ou endommagé pendant l'expédition de retour, la réclamation au titre de la garantie pourra être rejetée.

Comment obtenir le service au titre de la garantie ?

Vous devez contacter un fournisseur de service qualifié/agréé pour la réparation d'un produit dans le cadre de cette garantie. Pour trouver les coordonnées d'un tel fournisseur local, veuillez contacter votre point d'achat, ou allez sur le site Web de Rinnai (www.rinnai.us). Vous pouvez aussi téléphoner à Rinnai au 1-800-621-9419 ou écrire à Rinnai : 103 International Drive, Peachtree City, Georgia 30269, USA.

La preuve de votre achat est nécessaire pour bénéficier du service dans le cadre de la garantie. Vous pouvez montrer la preuve de l'achat avec une facture ou un ticket de caisse datés, ou en vous enregistrant dans les 30 jours suivant l'achat du produit. Veuillez remplir l'enregistrement en ligne sur www.rinnairegistration.com ou envoyez par la poste la carte d'enregistrement de l'appareil à Rinnai (adresse imprimée sur la carte). Pour thos sans l'accès à Internet, s'il vous plaît appeler 1-866-RINNAI1 (746-6241) La réception de cette carte d'enregistrement servira de preuve de l'achat du produit. Cependant la démarche d'enregistrement n'est pas une obligation pour valider cette garantie.

Qu'est-ce qui n'est pas couvert ?

Cette garantie ne couvre pas routes pannes ou difficultés de fonctionnement découlant de :

- accident, abus, mauvais usage
- altération
- application non prévue
- cas de force majeure
- installation incorrecte (comme sans y être limité mauvaise qualité de l'eau, dommages dus à la condensation, mauvaise ventilation, type de gaz ou pression d'eau inadéquats, absence de bac de drainage sous l'appareil)
- entretien inadéquat (comme sans y être limité accumulation de tartre, dommages dus au gel, blocage de ventilation)
- mauvais dimensionnement de l'installation.
- ou pour toutes autres causes autres que des défauts dans les matériaux et la main d'œuvre

Cette garantie ne s'applique pas pour tout produit sur lequel numéro de série ou date de fabrication auraient été effacés. Cette garantie ne couvre pas tout produit utilisé dans une application qui gère de l'eau traitée chimiquement, comme le chauffage de piscine ou de spa. Cette appareil reste utilisable pour remplir de baignoires de grande contenance avec de l'eau potable. Reportez-vous à la section relative à la qualité de l'eau dans le manuel d'installation et d'utilisation.

Limitation sur les garanties

Personne n'est autorisé a offrir toute autre garantie au nom de Rinnai America Corporation. Sauf pour ce qui est expressément communiqué ici, il n'y a aucune autre garantie, explicite ou implicite, y compris sans y être limité les garanties de valeur marchande ou d'adéquation à une finalité particulière, qui s'étendrait au-delà de la description de garantie fournie ici. De plus Rinnai n'est pas responsable de tous dommages spéciaux, accessoires, indirects ou consécutifs qui peuvent survenir, y compris les dommages aux personnes et aux biens, la perte d'usage, les désagréments ou les conséquences de mauvaise qualité d'installation,entretien ou utilisation. Certains états ne permettent pas l'exclusion ou la limitation des dommages annexes ou consécutifs, de ce fait la limitation qui précède peut ne pas être applicable à votre cas.

Toutes garanties implicites de valeur marchande et d'adéquation à une finalité spécifique autorisées par la législation locale seront de toutes façons limitées en durée à la période de couverture offerte par cette garantie limitée, sauf si la période légale locale d'application est plus courte. Certains états ne permettent pas de limitations sur le temps que durent les garanties implicites, de ce fait la limitation qui précède peut ne pas être applicable à votre cas.

Cette garantie vous donne des droits légaux spécifiques, et vous pouvez également avoir d'autres droits qui peuvent varier d'un état à l'autre.

Ask about **Rinnai**[®]

Rinnai's other fine products

EXPERIENCE OUR INNOVATION™



Tankless Water Heaters

- Residential and Commercial Applications
- Continuous Hot Water
- ENERGY STAR[®] qualified models
- Up to 9.8 GPM
- Internal or External Installation
- Digital Temperature Control



Direct Vent Furnaces

- High Efficiency
- Cool-to-the-touch Cabinet
- Blower Included
- Vent Terminal A Included
- Gas Conversion Kit Included



Direct-Vent Fireplace, RHFE-750ETRA

- Up to 83% AFUE Energy Efficiency
- Zero-Clearance Installation
- Available in Four Options of Fronts
- Remotes and Fan Included
- Gas Conversion Kit Available



Hydronic Air Handler

- Designed for Use with Rinnai Systems
- Domestic Hot Water Priority
- Optional Programmable Thermostat
- Zero Clearance to Combustibles
- Accommodates Standard Cased-Coils



Boilers

- Residential and Commercial Applications
- ENERGY STAR[®] qualified models
- Up to 96.5% AFUE efficiency
- Compact wall mounted design
- ASME accredited models



Condensing Tankless Water Heaters

- Residential and Commercial Applications
- ENERGY STAR[®] qualified models
- Up to 95% thermal efficiency
- Internal or External Installation
- Pair up with the Rinnai Air Handler for efficient home heating



Rinnai Impression - Outdoor Fireplace

- Options include one-sided open, two-sided open, and freestanding.
- No electrical requirements
- Propane or convertible to natural gas with conversion kit provided
- Modular construction offers design flexibility

Register your product at www.rinnairegistration.com or call 1-866-RINNAI1 (746-6241)

For information on Rinnai's products contact
 Rinnai America Corporation
 103 International Drive
 Peachtree City, GA 30269
 TOLL FREE: 1-800-621-9419
 FAX: 678-829-1666
www.rinnai.us



060 00012 31348 2

(VAM1620W, VB2020FFU)
 U287-1821X01(00)
 Printed in Japan