

**11" W.C. Line Sizing Chart - Pipe & Copper-**

11 inches W.C. inlet with a 1/2 inch W.C. Pressure Drop  
 Maximum capacity of pipe or tubing in thousands of BTU/hr of LP-Gas

CLICK ANYWHERE ON THIS PAGE TO RETURN TO  
 GAS PIPING SPECIFICATIONS INFORMATION  
 at InspectApedia.com

Size of Pipe or Copper Tubing, Inches	Length of Pipe or Tubing, Feet									
	10	20	30	40	50	60	70	80	90	100
Copper Tubing (O.D.)	3/8	49	34	27	23	20	19	---	---	---
	1/2	110	76	61	52	46	42	38	36	33
	5/8	206	141	114	97	86	78	71	67	62
	3/4	348	239	192	164	146	132	120	113	105
	7/8	536	368	296	253	224	203	185	174	161
Pipe Size	1/2	291	200	161	137	122	110	102	94	87
	3/4	608	418	336	287	255	231	212	198	185
	1	1146	788	632	541	480	435	400	372	349
	1-1/4	2353	1617	1299	1111	985	892	821	764	717
	1-1/2	3525	2423	1946	1665	1476	1337	1230	1144	1074
	2	6789	4666	3747	3207	2842	2575	2369	2204	2068
	2-1/2	10687	7379	5972	5089	4495	4071	3817	3478	3308
	3	19130	13148	10558	9036	8009	7256	6734	6211	5858

Size of Pipe or Copper Tubing, Inches	Length of Pipe or Tubing, Feet									
	125	150	175	200	225	250	275	300	350	400
Copper Tubing (O.D.)	3/8	---	---	---	---	---	---	---	---	---
	1/2	---	---	---	---	---	---	---	---	---
	5/8	---	---	---	---	---	---	---	---	---
	3/4	---	---	---	---	---	---	---	---	---
	7/8	---	---	---	---	---	---	---	---	---
Pipe Size	1/2	74	67	62	58	54	51	48	46	43
	3/4	155	141	129	120	113	107	101	97	89
	1	292	265	244	227	213	201	191	182	167
	1-1/4	600	544	500	465	437	412	392	374	344
	1-1/2	899	815	749	697	654	618	587	560	515
	2	1731	1569	1443	1343	1260	1190	1130	1078	992
	2-1/2	2799	2545	2324	2171	2025	1879	1791	1702	1566
	3	4878	4420	4102	3783	3568	3353	3196	3038	2795

**2 PSIG Line Sizing Chart - Pipe & Copper-**

2 PSIG inlet with a .2 PSIG Pressure Drop  
 Maximum capacity of pipe or tubing in thousands of BTU/hr of LP-Gas

Size of Pipe or Copper Tubing, Inches	Length of Pipe or Tubing, Feet									
	10	20	30	40	50	60	70	80	90	100
Copper Tubing (O.D.)	3/8	176	121	97	83	74	67	61	57	54
	1/2	363	249	200	171	152	138	127	118	111
	5/8	738	507	407	349	309	280	258	240	225
	3/4	1290	887	712	609	540	489	450	419	393
Pipe Size	1/2	1140	784	629	539	477	432	398	370	347
	3/4	2384	1638	1316	1126	998	904	832	774	726
	1	4491	3086	2479	2120	1880	1703	1567	1458	1368
	1-1/4	9215	6333	5087	4352	3858	3495	3215	2991	2806
	1-1/2	13809	9491	7623	6521	5781	5235	4816	4480	4203
	2	26597	18280	14683	12560	11135	10084	9277	8630	8096
	2-1/2	42391	29135	23402	20019	17747	16075	14788	13756	12904
	3	74938	51504	41369	35389	31373	29784	27400	25488	23872

Size of Pipe or Copper Tubing, Inches	Length of Pipe or Tubing, Feet									
	125	150	175	200	225	250	275	300	350	400
Copper Tubing (O.D.)	3/8	45	41	37	35	33	31	29	28	26
	1/2	93	84	77	72	67	64	60	58	53
	5/8	188	171	157	146	137	129	123	117	108
	3/4	329	298	274	255	239	226	215	205	188
Pipe Size	1/2	291	263	242	225	212	200	190	181	167
	3/4	608	551	507	471	442	418	397	379	348
	1	1145	1038	955	888	833	787	748	713	656
	1-1/4	2350	2129	1963	1824	1710	1616	1539	1464	1345
	1-1/2	3523	3191	2939	2731	2560	2420	2306	2194	2017
	2	8448	7652	5659	5259	4931	4661	4438	4223	3883
	2-1/2	10814	9795	9021	8384	7860	7429	7074	6731	6187
	3	19177	17316	15946	14820	13897	13135	12508	11901	10940

Data Calculated per NFPA #58 & #54

**10 PSIG Line Sizing Chart -Pipe & Copper-**

10 PSIG inlet with a 1 PSIG Pressure Drop

Maximum capacity of pipe or tubing in thousands of BTU/hr of LP-Gas

Size of Pipe or Copper Tubing, Inches	Length of Pipe or Tubing, Feet										
	10	20	30	40	50	60	70	80	90	100	
Copper Tubing (O.D.)	3/8	558	383	309	265	235	213	196	182	171	161
	1/2	1387	870	700	599	531	481	443	412	386	365
	5/8	2360	1622	1303	1115	988	896	824	767	719	679
	3/4	3993	2475	2205	1887	1672	1515	1394	1297	1217	1149
Pipe Size	1/2	3339	2296	1843	1577	1398	1267	1165	1084	1017	961
	3/4	6982	4799	3854	3298	2923	2649	2437	2267	2127	2009
	1	13153	9040	7259	6213	5507	4989	4590	4270	4007	3785
	1-1/4	27004	18560	14904	12756	11306	10244	9424	8767	8226	7770
	1-1/2	40461	27809	22331	19113	16939	15348	14120	13136	12325	11642
	2	77924	53556	43008	36809	32623	29559	27194	25299	23737	22422
	2-1/2	124198	85360	68548	58668	51996	47112	43342	40323	37833	35737
	3	219563	150904	121183	103716	91921	83287	76622	71285	66883	63178

Size of Pipe or Copper Tubing, Inches	Length of Pipe or Tubing, Feet										
	125	150	175	200	225	250	275	300	350	400	
Copper Tubing (O.D.)	3/8	142	130	118	111	104	90	89	89	82	76
	1/2	323	293	269	251	235	222	211	201	185	172
	5/8	601	546	502	467	438	414	393	375	345	321
	3/4	1018	923	843	790	740	700	664	634	584	543
Pipe Size	1/2	852	772	710	660	619	585	556	530	488	454
	3/4	1780	1613	1484	1381	1296	1224	1162	1109	1020	949
	1	3354	3039	2796	2601	2441	2305	2190	2089	1922	1788
	1-1/4	6887	6240	5741	5340	5011	4733	4495	4289	3945	3670
	1-1/2	10318	9349	8601	8002	7508	7092	6735	6426	5911	5499
	2	19871	18005	16564	15410	14459	13658	12971	12375	11385	10591
	2-1/2	31671	28697	26400	24561	23045	21769	20674	19724	18146	16880
	3	55990	50732	46671	43420	40740	38484	36549	34869	32079	29841

**10 PSIG Line Sizing Chart -Polyethylene Tubing-**

10 PSIG inlet with a 1 PSIG Pressure Drop

Maximum capacity of plastic tubing in thousands of BTU/hr of LP-Gas

Size of Plastic Tubing NPS	SDR	Length of Tubing, Feet									
		10	20	30	40	50	60	70	80	90	100
1/2 CTS	7.00	1387	954	766	655	581	526	484	450	423	399
1/2 IPS	9.33	3901	2681	2153	1843	1633	1480	1361	1267	1188	1122
3/4 IPS	11.00	7811	5369	4311	3690	3270	2693	2726	2536	2379	2248
1 CTS	11.50	9510	6536	5249	4492	3981	3607	3319	3088	2897	2736
1 CTS	12.50	10002	6874	5520	4725	4187	3794	3490	3247	3046	2878
1 IPS	11.00	14094	9687	7779	6658	5901	5346	4919	4578	4293	4055
1 1/4 IPS	10.00	24416	16781	13476	11534	10222	9262	8521	7927	7438	7026
2 IPS	11.00	66251	45534	36566	31295	27737	25131	23120	21509	20181	19063

		125	150	175	200	225	250	275	300	350	400
1/2 CTS	7.00	354	321	295	274	257	243	231	220	203	189
1/2 IPS	9.33	995	901	829	772	724	684	649	620	570	530
3/4 IPS	11.00	1992	1805	1660	1545	1449	1369	1300	1241	1141	1062
1 CTS	11.50	2425	2197	2022	1881	1765	1667	1583	1510	1389	1293
1 CTS	12.50	2551	2311	2126	1978	1856	1753	1665	1588	1461	1359
1 IPS	11.00	3594	3257	2996	2787	2615	2470	2346	2238	2059	1916
1 1/4 IPS	10.00	6226	5642	5190	4829	4531	4280	4064	3878	3567	3318
2 IPS	11.00	16895	15308	14084	13102	12293	11612	11028	10521	9680	9005

Data Calculated per NFPA #58 & #54

**11” W.C. Line Sizing Chart - CSST -**

11 inches W.C. inlet with a 1/2 inch W.C. Pressure Drop

Maximum capacity of Corrugated Stainless Steel Tubing in thousands of BTU/hr of LP-Gas

Size of Corrugated Stainless Steel Tubing, Inches		Length of Tubing, Feet						
	EHD**	5	10	15	20	25	30	40
3/8	10A	108	81	68	60	55	51	45
1/2	15A	225	160	130	113	101	92	80
3/4	20A	528	371	302	261	233	213	184
1	25A	918	682	508	436	386	350	300

Size of Corrugated Stainless Steel Tubing, Inches		Length of Tubing, Feet						
	EHD**	50	60	80	100	150	200	300
3/8	10A	41	38	34	31	26	23	19
1/2	15A	72	65	57	51	41	36	29
3/4	20A	164	150	129	115	94	81	66
1	25A	266	241	207	183	147	126	102

**2 PSIG Line Sizing Chart - CSST -**

2 PSIG inlet with a 1 PSIG Pressure Drop

Maximum capacity of Corrugated Stainless Steel Tubing in thousands of BTU/hr of LP-Gas

Size of Corrugated Stainless Steel Tubing, Inches		Length of Tubing, Feet							
	EHD**	5	10	15	20	25	30	40	50
3/8	10A	570	429	363	332	294	273	242	221
1/2	15A	1660	1176	961	833	745	681	590	528
3/4	20A	4051	2850	2320	2004	1790	1632	1410	1259
1	25A	7934	5468	4398	3768	3343	3031	2597	2304

Size of Corrugated Stainless Steel Tubing, Inches		Length of Tubing, Feet						
	EHD**	60	80	100	150	200	300	500
3/8	10A	205	182	166	141	125	106	86
1/2	15A	482	418	374	306	265	216	168
3/4	20A	1148	992	885	721	623	507	391
1	25A	2089	1790	1588	1277	1094	880	669

\* Table includes losses for four 90 degree bends and 2 end fittings. To compute flow capacity for tubing runs with a larger number of bends and/or fittings, add the appropriate number of feet to the actual run length using the following formula:

$$L = 1.3(n)$$

L = Number of feet to be added to actual run length.

n = Number of bends and/or fittings over six.

\*\* EHD - Equivalent Hydraulic Diameter - A measure of the relative hydraulic efficiency between different tubing sizes. The greater the value of EHD, the greater the gas capacity of the tubing.

**Data Calculated per NFPA #58 & #54**

**Normal State Liquid Flow Chart**

Use this chart for flows directly from storage ("Normal State").

For elevated pressure systems, ask for our "Elevated Pressure Liquid Flow Chart".

Maximum capacity of Type K Copper or SCH 40 iron pipe in GPH of LP-Gas

Based on 1 PSIG pressure drop and 0°F

**Gallons  
per  
Hour**

Size of Type K Copper or SCH 40 Pipe	ID	Length of Pipe, Feet									
		10	20	30	40	50	60	70	80	90	100
Copper Tubing (I.D.)	1/4	79	55	45	39	35	32	29	27	26	24
	3/8	164	116	95	82	73	67	62	58	54	52
	1/2	330	233	190	165	147	134	124	116	110	104
	5/8	569	402	328	284	254	232	215	201	189	180
	3/4	801	566	462	400	358	327	302	283	267	253
	1	1587	1193	974	843	754	689	637	596	562	533
Pipe Size	1/2	330	234	222	162	150	132	126	114	108	105
	3/4	696	492	402	348	312	282	264	246	228	222
	1	1356	954	780	678	606	552	516	480	450	426
	1-1/4	2748	1944	1590	1374	1230	1122	1044	9723	918	870
	1-1/2	4092	2892	2364	2046	1830	1668	1548	1452	1362	1296
	2	7884	5574	4548	3942	3534	3222	2982	2790	2628	2490

	ID	125	150	175	200	225	250	275	300	350	400
Copper Tubing (I.D.)	1/4	22	---	---	---	---	---	---	---	---	---
	3/8	46	42	39	36	34	32	31	30	27	26
	1/2	93	85	79	73	69	66	63	60	55	52
	5/8	161	147	136	127	120	113	108	104	96	90
	3/4	226	206	191	179	168	160	152	146	135	126
	1	477	435	403	377	355	337	321	308	285	266
Pipe Size	1/2	96	---	---	---	---	---	---	---	---	---
	3/4	198	180	168	156	150	138	132	126	120	108
	1	384	348	324	300	282	276	258	246	228	216
	1-1/4	780	708	660	612	582	552	522	504	468	438
	1-1/2	1158	1056	978	918	864	822	780	750	690	648
	2	2232	2034	1884	1764	1662	1578	1500	1440	1332	1248

	ID	450	500	550	600	650	700	750	800	900	1000
Copper Tubing (I.D.)	1/4	---	---	---	---	---	---	---	---	---	---
	3/8	24	23	---	---	---	---	---	---	---	---
	1/2	49	46	44	42	41	39	38	36	34	33
	5/8	84	80	76	73	70	68	65	63	60	56
	3/4	119	113	108	103	99	95	92	89	84	80
	1	251	238	227	217	209	201	194	188	177	168
Pipe Size	1/2	---	---	---	---	---	---	---	---	---	---
	3/4	---	---	---	---	---	---	---	---	---	---
	1	204	182	180	174	168	162	156	152	144	132
	1-1/4	408	390	372	354	342	330	318	306	288	276
	1-1/2	612	582	552	528	510	492	474	456	432	408
	2	1176	1116	1068	1020	978	942	912	882	828	786

Values based on Darcy's equation with a 20% reduction in flow to account for flashing of liquid during flow through tank valves, dip pipes etc. in the piping.

Calculation assumes turbulent flow (i.e. Reynold's number > 4000) and the weight density of propane taken at 0°F.

### Vapor Meter Index Conversions

Meter reads in gallons multiply reading by 36.39 to get cubic feet  
 Meter reads in cubic feet divide reading by 36.39 to get gallons

Propane Properties	
Physical Constants	Commercial Propane
Formula	C <sub>3</sub> H <sub>8</sub>
Freezing Point, °F at 30" Mercury	-306
Boiling Point, °F, 30" Mercury	-44
Specific Gravity of Vapor, 60°F, 30" Mercury	1.52
Specific Gravity of Liquid, 60°/ 60°F	.51
Weight per Gallon of Liquid at 60°F, lbs.	4.24
BTU per Gallon (Vaporized)	91690
BTU per Pound (Vaporized)	21591
BTU per Cubic Foot (Vaporized)	2520
Cu. Ft. of Vapor /Gal of Liquid at 60°F, 30" Hg.	36.39
Cu. Ft. of Vapor /Pound of Liquid at 60°F, 30" Hg.	8.55

Energy Equivalents		
Multiply	By	To Obtain
BTU	777.0	Foot Pounds
Therms	100,000	BTU
KWH	3413	BTU/HR
Calories	3.968	BTU
Boiler HP	33,480	BTU/HR

Equivalents of Pressure		
Multiply	By	To Obtain
lb/in <sup>2</sup>	1.732 27.727 6.895	oz/in <sup>2</sup> in of water (kPa) kilopascals
in of water	0.0361 0.577 0.249	lb/in <sup>2</sup> oz/in <sup>2</sup> (kPa) kilopascals
oz/in <sup>2</sup>	1.732	in of water
kg/cm <sup>2</sup>	14.22	psi

Converting Volumes Of Gas		
Multiply CFH Of :	By	To Obtain CFH Of :
Natural Gas	0.775 0.628 0.685	Air Propane Mixed Gas
Propane	1.237 1.598 1.09	Air Natural Gas Mixed Gas

Flow capacities thru pipes, valves, regulators etc., given in CFH for a particular gas, can be readily converted to CFH of the desired gas using the following multipliers.

Vapor Pressure Of Propane	
Temperature °F	Pressure PSIG
-40	1.3
-30	5.5
-20	10.7
-10	16.7
0	23.5
10	31.3
20	40.8
30	51.6
40	63.3
50	77.1
60	92.5
70	109.3
80	128.1
90	149.3
100	172.3
110	197.3
120	225.0

Vaporization Capacity of Popular ASME Propane Storage Vessels					
Tank Size Gallons	BTU/HR 60% Full	BTU/HR 50% Full	BTU/HR 40% Full	BTU/HR 20% Full	BTU/HR 10% Full
120	160,800	144,720	128,640	96,480	72,360
250	282,000	253,800	225,600	169,200	126,900
500	440,300	396,270	352,240	264,180	198,135
1000	791,300	712,170	633,040	474,780	356,085
12000	4,519,200	4,067,280	3,615,360	2,711,520	2,033,640
18000	5,351,900	4,816,710	4,281,520	3,211,140	2,408,355
30000	8,621,900	7,759,710	6,897,520	5,173,140	3,879,855

For Other Air Temperature, Use the Following Multipliers				
Air Temp	Multiplier		Air Temp	Multiplier
-15 F	0.25		+5 F	1.25
-10 F	0.50		+10 F	1.50
-5 F	0.75		+15 F	1.75
0 F	1.00		+20 F	2.00

These factors are used to convert volumes of gases at various observed pressures and temperatures to the standard 4 oz. base pressure and/or the standard 60°F base temperature.

**Pressure Example:** 1000 Cubic Feet read at 10 PSIG equals 1652 (1000 X 1.652) Cubic Feet at a standard 4 oz. base pressure.

**Temp Example:** 1000 Cubic Feet read at 10°F equals 1106.8 (1000 X 1.106.8) Cubic Feet at a standard 60°F base temperature.

Base Pressure Conversion	
Observed Gauge Pressure (PSIG)	Multiplier To Convert To 4 oz. Base
0	0.983
1/4	1.000
1/2	1.017
5/8	1.025
1	1.050
2	1.117
3	1.184
4	1.251
5	1.318
6	1.385
7	1.452
8	1.518
9	1.584
10	1.652
12	1.786
14	1.920
16	2.054
18	2.187
20	2.321
22	2.455
24	2.589
26	2.722
28	2.856
30	2.990
35	3.324
40	3.659
45	3.993
50	4.328
60	4.997
70	5.666
80	6.334
90	7.003
100	7.672
110	8.341
120	9.010
130	9.679
140	10.35
150	11.02
160	11.69
170	12.35
180	13.02
190	13.69
200	14.36

Base Temperature Conversion					
Observed Temp °F	Multiplier To 60 °F Base	Observed Temp °F	Multiplier To 60 °F Base	Observed Temp °F	Multiplier To 60 °F Base
0	1.1309	36	1.0486	72	.9974
1	1.1285	37	1.0464	73	.9755
2	1.1260	38	1.0443	74	.9737
3	1.1236	39	1.0422	75	.9719
4	1.1211	40	1.0401	76	.9701
5	1.1187	41	1.0381	77	.9682
6	1.1163	42	1.0360	78	.9664
7	1.1139	43	1.0339	79	.9646
8	1.1115	44	1.0319	80	.9628
9	1.1091	45	1.0298	81	.9611
10	1.1068	46	1.0278	82	.9593
11	1.1044	47	1.0257	83	.9575
12	1.1021	48	1.0237	84	.9557
13	1.0997	49	1.0217	85	.9540
14	1.0974	50	1.0197	86	.9522
15	1.0951	51	1.0177	87	.9505
16	1.0828	52	1.0157	88	.9488
17	1.0905	53	1.0137	89	.9470
18	1.0882	54	1.0117	90	.9453
19	1.0859	55	1.0097	91	.9436
20	1.0836	56	1.0078	92	.9418
21	1.0814	57	1.0058	93	.9401
22	1.0791	58	1.0039	94	.9384
23	1.0769	59	1.0019	95	.9367
24	1.0746	60	1.0000	96	.9351
25	1.0724	61	0.9981	97	.9334
26	1.0702	62	.9962	98	.9317
27	1.0680	63	.9942	99	.9300
28	1.0658	64	.9923	100	.9284
29	1.0636	65	.9904	101	.9267
30	1.0614	66	.9886	102	.9250
31	1.0593	67	.9867	103	.9234
32	1.0571	68	.9848	104	.9217
33	1.0550	69	.9829	105	.9201
34	1.0528	70	.9811	106	.9185
35	1.0506	71	.9792	107	.9169

Capacity in BTU/HR of both Propane and Natural Gas is tabulated for the common MTD drill sizes used in burner work. Conversion sizing is readily accomplished by selecting the correct BTU requirement for any particular drill size. The Drill Size Data chart at the right is offered for reference to other sizes.

Orifice Capacity Chart - BTU/HR					
Drill Size	Propane 11" Water	Natural 3.5" Water	Drill Size	Propane 11" Water	Natural 3.5" Water
.006	249	88	45	47000	16500
.007	338	119	44	51600	18150
.008	445	157	43	55300	19420
.009	570	201	42	61100	21470
.010	703	248	41	64400	22600
.011	845	298	40	67000	23550
.012	1005	355	39	69200	24250
80	1270	447	38	72000	25280
79	1470	514	37	75500	26500
78	1790	637	36	79300	27800
77	2260	792	35	84500	29700
76	2790	979	34	86200	30250
75	3080	1078	33	94000	31400
74	3540	1422	32	98300	33080
73	4020	1418	31	100600	35400
72	4370	1531	30	115300	40060
71	4730	1656	29	129500	45400
70	5490	1921	28	137500	48400
69	5960	2090	27	145000	50800
68	6720	2355	26	151000	53000
67	7150	2550	25	156000	54800
66	7600	2668	24	161500	56700
65	8560	3000	23	166000	58250
64	9050	3180	22	172000	60600
63	9570	3355	21	176500	62200
62	10100	3540	20	181100	63700
61	10600	3730	19	193000	67700
60	11170	3922	18	200500	70600
59	11750	4120	17	290999	73500
58	12300	4320	16	219000	76900
57	12930	4530	15	236500	79600
56	15100	5280	14	242000	81400
55	18850	6620	13	239500	83200
54	21200	7330	12	250000	85700
53	24700	8670	11	255000	89500
52	28200	9890	10	261500	91700
51	31400	11000	Values Based on: Propane 2500 BTU per cubic foot. Natural 1000 BTU per cubic foot.		
50	34200	12000			
49	37200	13750			
48	40400	14160			
47	43000	15100			
46	45800	16050			
45	47000	16500			

Drill Size Data			Drill Size Data			Drill Size Data			
Inch Dia.	Mtd Size	Dec Inch	Inch Dia.	Mtd Size	Dec Inch	Inch Dia.	Mtd Size	Dec Inch	
1/64	80	.0135	7/64	36	.1065	17/64	F	.257	
	79	.0145		..	.1093		G	.261	
	..	.0156		35	.110		..	.2656	
	78	.016		34	.111		H	.266	
	77	.018		33	.113		I	.272	
	76	.020	1/8	32	.116	9/32	J	.277	
	75	.021		31	.120		K	.281	
	74	.0225		..	.125		..	.2812	
	73	.024		30	.1285		L	.290	
	72	.025		29	.136		M	.295	
1/32	71	.026	9/64	28	.1405	19/64	..	.2968	
	70	.028		..	.1406		N	.302	
	69	.0292		27	.144		..	.3125	
	68	.030		26	.147		O	.316	
	..	.0312		25	.1495		P	.323	
	67	.032	5/32	24	.152	21/64	..	.3281	
	66	.033		23	.154		Q	.332	
	65	.035		..	.1562		R	.339	
	64	.036		22	.157		..	.3437	
	63	.037		21	.159		S	.348	
	62	.038	11/64	20	.161	23/64	T	.358	
	61	.039		19	.166		..	.3593	
	60	.040		18	.1695		U	.368	
	59	.041		..	.1719		..	.375	
	58	.042		17	.175		V	.377	
3/64	57	.043	3/16	16	.177	25/64	W	.386	
	56	.0465		15	.180		..	.3906	
	..	.0469		14	.182		X	.397	
	55	.0520		13	.185		Y	.404	
	54	.0550		..	.1875		..	.4062	
1/16	53	.0595		12	.189	7/16	Z	.413	
	..	.0625		11	.191		..	.4375	
	52	.0635		10	.1935		29/64	..	.4531
	51	.0670		9	.196		15/32	..	.4687
	50	.070		8	.199		31/64	..	.4843
5/64	49	.073	13/64	7	.201				
	48	.076		..	.2031				
	..	.0781		6	.204				
	47	.0785		5	.2055				
	46	.081		4	.209				
	45	.082	7/32	3	.213				
	44	.086		..	.2187				
	43	.089		2	.221				
	42	.0935		1	.228				
	..	.0937		A	.234				
	41	.096	15/64	..	.2343				
	40	.098		B	.238				
	39	.0995		C	.242				
	38	.1015		D	.246				
	37	.104		1/4	E		.250		

**Thread Identification Guide**

The table lists the thread sizing for the various fittings used in the propane industry. Using the table as a guide, service personnel can identify the common size and style of fittings encountered in the field.

**Note:**

Steel pipe is sized by the nominal I.D. of the pipe. The O.D. is listed for reference.

Copper tubing is sized by the nominal O.D. of the tubing.

Size	Pipe Size		45° Flare Thread	Inverted Flare Thread	Compression Thread	Break Away Thread
	Thread	O.D.				
1/8"	1/8" -27	.405"	5/16" -24	5/16" -28	5/16" -24	5/16" -24
3/16"	---	---	3/8" -24	3/8" -24	3/8" -24	3/8" -24
1/4"	1/4" -18	.540"	7/16" -20	7/16" -24	7/16" -24	7/16" -24
5/16"	---	---	1/2 -20	1/2 -20	1/2 -24	1/2 -20
3/8"	3/8" -18	.675"	5/8" -18	5/8" -18	9/16" -24	9/16" -20
7/16"	---	---	11/16" -16	11/16" -18	5/8" -24	5/8" -24
1/2"	1/2" -24	.840"	3/4" -16	3/4" -18	11/16" -20	11/16" -16
5/8"	---	---	7/8" -14	7/8" -18	13/16" -18	7/8" -18
3/4"	3/4" -14	1.05"	1-1/16" -14	1-1/16" -16	1" -18	1" -18
7/8"	---	---	1-1/4" -12	1-3/16" -16	1-1/8" -18	1-1/8" 18
1"	1" -11-1/2	1.315"	1-3/8" -12	1-5/16 -16	1-1/4" -18	1-1/4" -18
1-1/4"	1-1/4" -11-1/2	1.66"	---	---	---	---
1-1/2"	1-1/2" -11-1/2	1.90"	---	---	---	---
2"	2" -11-1/2	2.375"	---	---	---	---
2-1/2"	2-1/2" -8	2.875"	---	---	---	---
3"	3" -8	3.500"	---	---	---	---



**Rego 2-1/2" Multivalves**

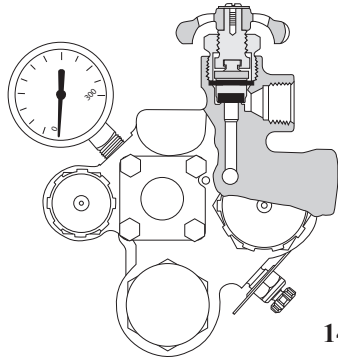

**1475 Shown**

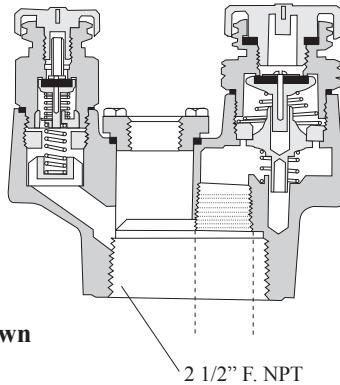

**1470 Series Valves**

(Valve Nos. 1470, 1475, 1476, 1477, 1478, 1479, 1480, 1481)

<u>Filler Kit</u>	<u>Vapor Return Kit</u>	<u>Shutoff Kit</u>
1475-80	2418-51	3100 Series

**2418 Valve**

<u>Filler Kit</u>	<u>Vapor Return Kit</u>	<u>Shutoff Kit</u>
2418-50	2418-51	2100 Series

**6303 Valve (No Float Gauge Port)**

<u>Filler Kit</u>	<u>Vapor Return Kit</u>	<u>Shutoff Kit</u>
8475-80	2418-51	3100 Series

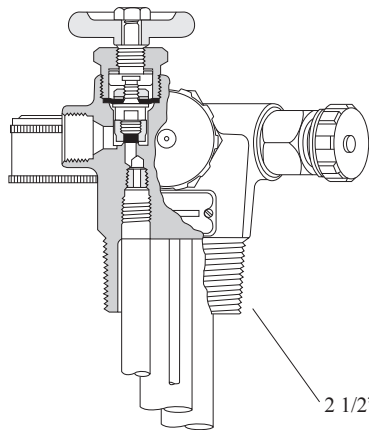

**2550 Valve**

<u>Filler Kit</u>
2418-50
<u>Vapor Return Kit</u>
2418-51
<u>Shutoff Kit</u>
2100 Series

2 1/2" M. NPT

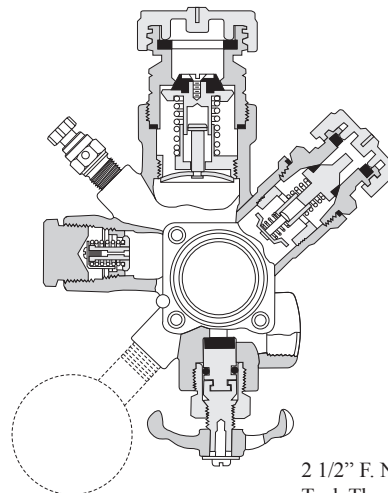

**6477 Series Valves**  
(Valve Nos. 6477, 6477A)

<u>Filler Kit</u>
8475-80
<u>Vapor Return Kit</u>
8475-51A
<u>Shutoff Kit</u>
3100 Series for 6477
8100 Series for 6477A

2 1/2" F. NPT  
Tank Thread

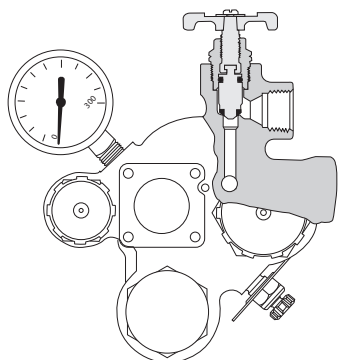

**G8475 Shown**

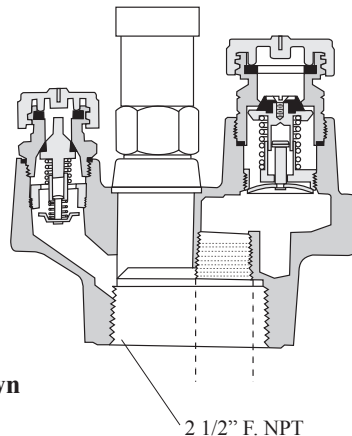

**8475 Series Valves (pre 1962)**

(Valve Nos. 8475, 8477, 8575, 8577, G8475, G8477)

<u>Filler Kit</u>	<u>Vapor Return Kit</u>	<u>Shutoff Kit</u>
8475-80	8475-51A	8100 Series

**G8475 Series Valves (post 1962)**

(Valve Nos. G8475, G8477)

<u>Filler Kit</u>	<u>Vapor Return Kit</u>	<u>Shutoff Kit</u>
8475-80	8475-81A	19100 Series

2 1/2" F. NPT

**Rego 1-1/2" Multivalves**

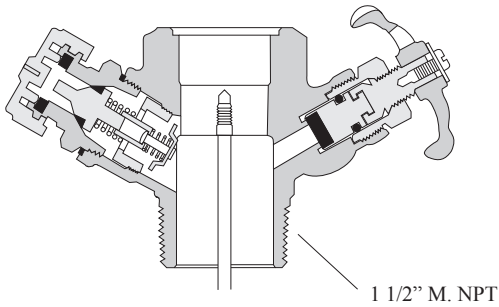

**8484 Series Valves**  
(Valve Nos. 8484, 8484A)

Vapor Return Kit

8475-51A for 8484  
8475-81A for 8484A

Shutoff Kit

8100 Series for 8484  
19100 Series for 8484A

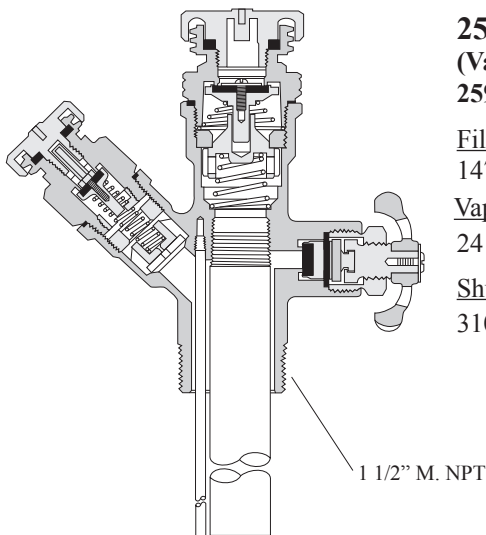

**2593 Series Valves**  
(Valve Nos. 2593, 2593K,  
2594, 2594K)

Filler Kit

1475-80

Vapor Return Kit

2418-51

Shutoff Kit

3100 Series

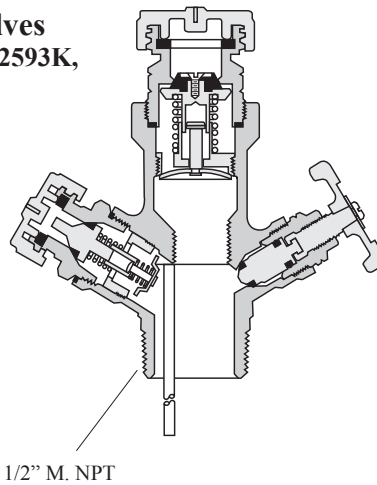

**8593 Series Valves**  
(Valve Nos. 8593, 8593A,  
8593AR, 8593K, 8594,  
8594A, 8594K)

Filler Kit

8475-80

Vapor Return Kit

8475-51A for 8593, 8593K  
8594, 8594K  
8475-81A for 8593A, 8593AR

Shutoff Kit

8100 Series for 8593, 8593K  
8594, 8594K  
19100 Series for 8593A,  
8593AR

**Rego Multivalves**

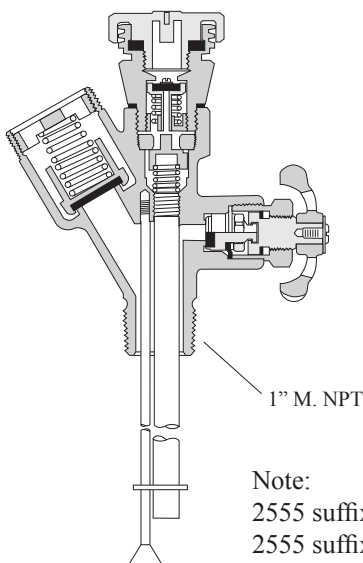

**2555 Series Valves**  
(Valve Nos. 2555, 2555A)

**2555**

Filler Kit  
2557-1

Shutoff Kit  
3100 Series

**2555A**

Filler Kit  
8555-80

Shutoff Kit  
8100 Series

Note:  
2555 suffix "R" had 1-1/4" Filler  
2555 suffix "W" had POL Filler

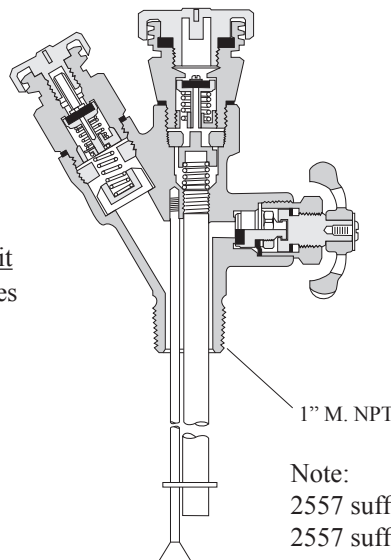

**2557 Series Valves**  
(Valve Nos. 2557, 2557A)

Filler Kit  
2557-1

Vapor Return Kit  
2418-51

Shutoff Kit  
3100 Series

Note:  
2557 suffix "R" had 1-1/4" Filler  
2557 suffix "W" had POL Filler

**Rego Multivalves**

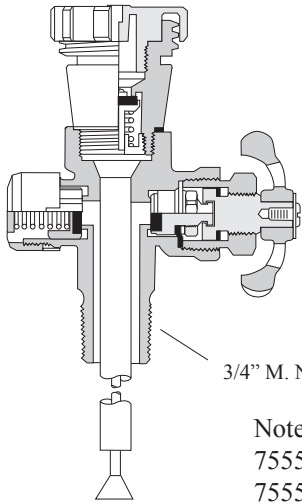

**7555 Series Valves**

Filler Kit  
2557-1

Shutoff Kit  
3100 Series

3/4" M. NPT

Note:  
7555 suffix "R" had 1-1/4" Filler  
7555 suffix "W" had POL Filler

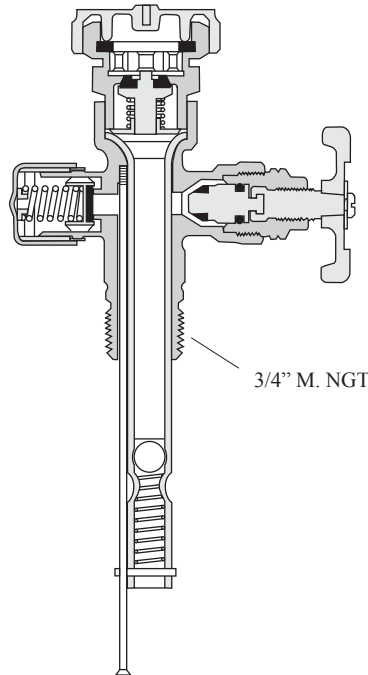

**8555 Series Valves**  
(Valve Nos. 8555, 8555D,  
8555R, 8555S)

Filler Kits  
Pre-1962 Not Available  
6542B-80 (1962 - Oct 1990)  
8555-80 (Post Oct 1990)

Shutoff Kits  
Pre-1962 Not Available  
903-51 for 8555S  
19100 Series for  
8555D, 8555R

3/4" M. NGT

**Rego Multivalves**

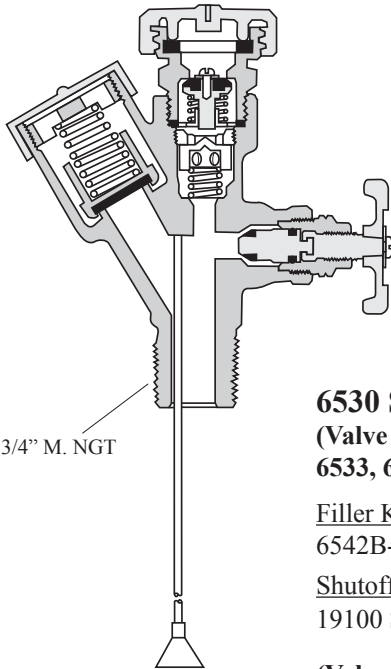

**6530 Series Valves**  
(Valve Nos. 6532, 6532A,  
6533, 6533A,)

Filler Kit  
6542B-80

Shutoff Kit  
19100 Series

(Valve Nos. 6532D 6533D)

Filler Kit  
6542B-80

Shutoff Kit  
903-51

3/4" M. NGT

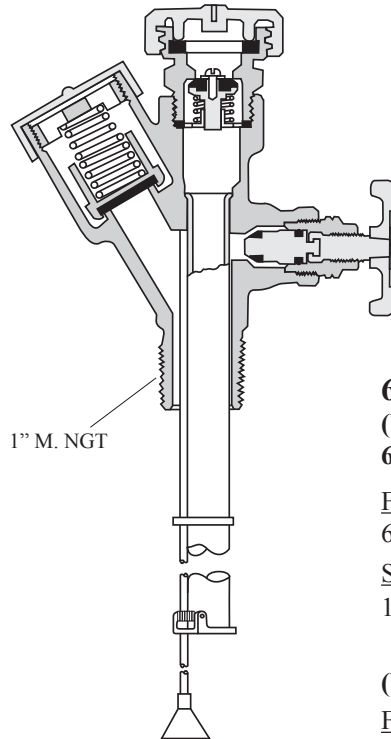

**6540 Series Valves**  
(Valve Nos. 6542, 6542A,  
6543, 6543A)

Filler Kit  
6542B-80

Shutoff Kit  
19100 Series

(Valve Nos. 6542D 6543D)

Filler Kit  
6542B-80

Shutoff Kit  
903-51

1" M. NGT

**Rego Multivalves**

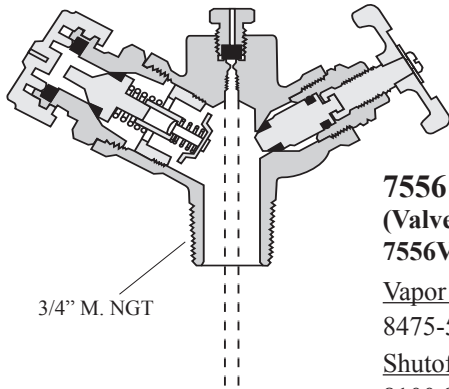

3/4" M. NGT

**7556 Series Valves**  
(Valve Nos. 7556, 7556VR, 7556R)

Vapor Return Kit

8475-51A

Shutoff Kits

8100 Series for Pre - 1962

19100 Series for Post 1962

Chek-Lok

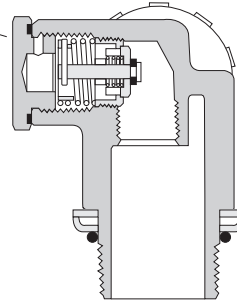

**6179 Filler**

Filler Kit

7579-80

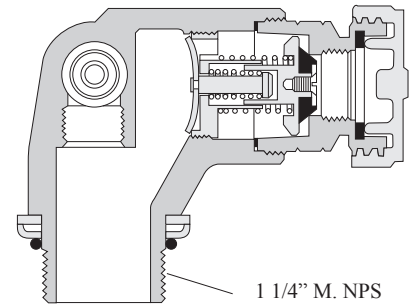

1 1/4" M. NPS

**Rego Filler Valves**

**1 1/4" Filler**

(Valve Nos. 7579, 7579P, 7579S, 6579)

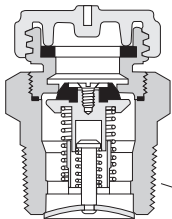

1 1/4" M. NPT  
1 1/2" M. NPT (for "S")

Filler Kits

7579-80 Standard Kit

7579-50 Kit w/Upper Body

**3/4" Filler**

(Valve Nos. 7547, 7747)

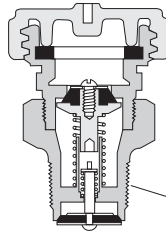

3/4" M. NPT

Filler Kits

7547B-80 Standard Kit

7547B-50 Kit w/Upper Body

**3/4" Filler**

(Valve Nos. 7647, 7647D)

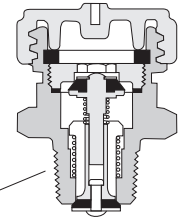

3/4" M. NPT

Filler Kit

7647B-80 Standard Kit

**Rego Vapor Return Valves**

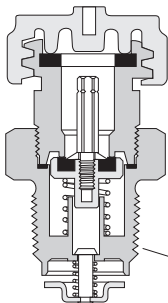

3/4" M. NPT

**7573 Identification Note**

7573A has flat seat and 13/16" wrench flats on upper body.

7573D has tapered seat and internal 1/2" hex on upper body.

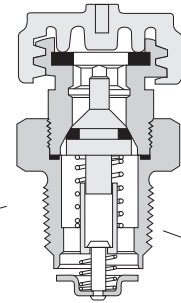

3/4" M. NPT

**7573A Vapor Return**

Vapor Return Kit

7573A-81

**7573D Vapor Return**

Vapor Return Kit

7573D-81

## Rego Cylinder Valves

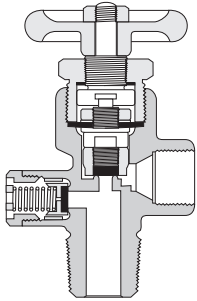

### **2000 Series Valves**

(Valve Nos. 2100, 2110, 2410, 2127, 2128, 2133, 2143, 2433, 2533, 2918, 2924, 2925, 2926, 2927, 2928)

Valve had large bonnet and diaphragm assembly. Flat seat.

**Repair parts are no longer available**

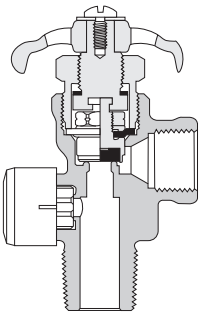

### **3100 & 7100 Series Valves**

(Valve Nos. 3101, 3102, 3103, 3109, 3115, 7103, 7104, 7112, 7133, 7139, 7140, 7146, 7149, 7153, 7183)

Diaphragm style stem seal. Flat seat.

#### Repair Kits

3100-80A Complete bonnet assembly. Renews valve to original assembly.

3100-80B Diaphragm assembly.

3100-81K Complete bonnet assembly. Converts valve to Oring stem seal.

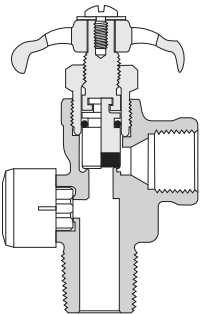

### **8100 Series Valves**

(Valve Nos. 8103, 8115, 8180)

Oring style stem seal. Flat seat.

#### Repair Kit

8100-50 Complete bonnet assembly.

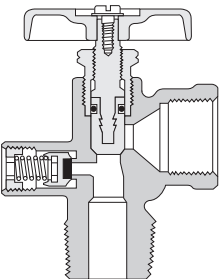

### **900 Series Valves**

(Valve Nos. 901, 903, 906, 9061)

Compact style bonnet assembly.

Oring style stem seal. Nylon "push-on" tapered seat.

#### Repair Kit

903-51 Complete bonnet assembly.

**Rego Cylinder Valves**

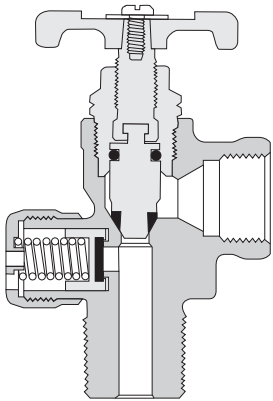

**9100 Series Valves**

(Valve Nos. 9101, 9103, 9105, 9106, 9107, 9115)

Oring style stem seal. Tapered seat.

Repair Kits

- 19100-50B Complete bonnet assembly. Renews valve to original assembly.
- 19104-50 Converts valve to MultiBonnet.

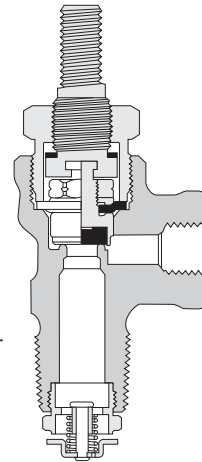

**7130BR Tractor Valve**

Bonnet Assembly

7130BR-1

Diaphragm Assembly

3100-50B

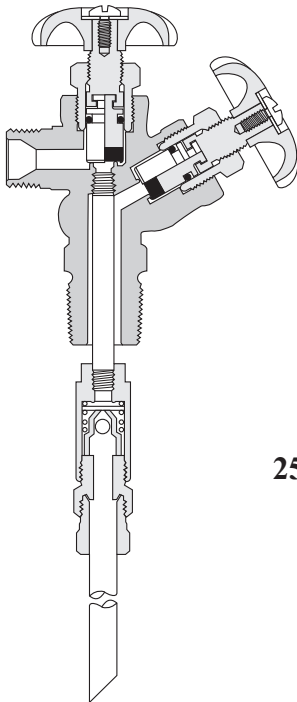

**8556 Dual Service Valve**

Bonnet Assemblies

- 8100-50 (pre-1962 valves)
- 19100-50 (post 1962 valves)

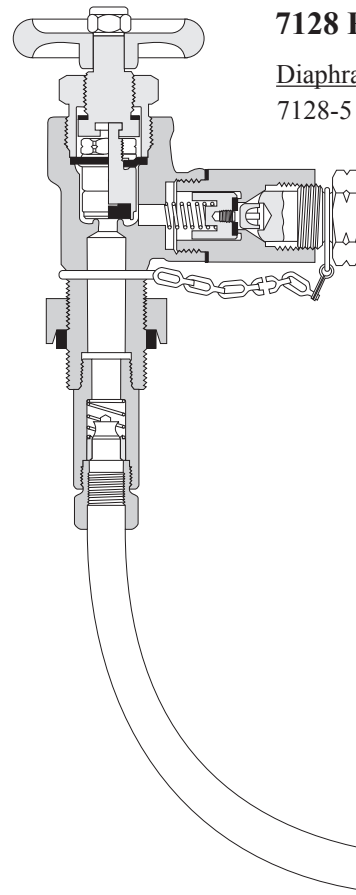

**7128 Railroad Valve**

Diaphragm Assembly

7128-5

**2547 & 8547 Plumbers Pot Valve**

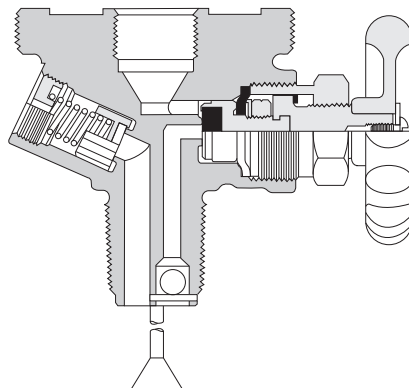

Repair Kits

- 3100-80A Bonnet Assembly for 2547
- 3100-80B Diaphragm for 2547
- 8100-50 Bonnet Assembly for 8547

**Filler Repair Kits & Contents**

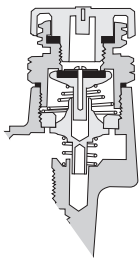

1475-80  
Seat disc & stem assy;  
Spring; Washer.

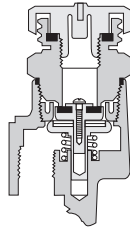

2418-50  
Reference only.  
Kit is obsolete.

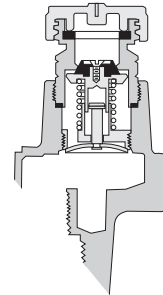

8475-50  
Body; Gaskets;  
Seat disc & stem assy;  
Spring; Washer.

8475-80  
Gaskets;  
Seat disc & stem assy;  
Spring; Washer.

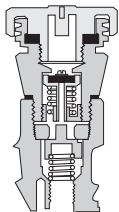

2557-1  
Reference only.  
Kit is obsolete.

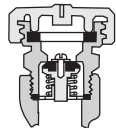

6542B-50  
Body; Gaskets;  
Seat disc & stem assy;  
Spring; Stem.

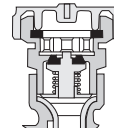

8555-50  
Body; Gaskets;  
Seat disc & stem assy;  
Spring; Stem.

6542B-80  
Gaskets;  
Seat disc & stem assy;  
Spring; Stem.

8555-80  
Gaskets;  
Seat disc & stem assy;  
Spring; Stem.

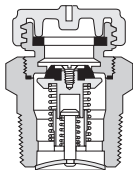

7579-50  
Body; Gaskets;  
Seat disc & stem assy;  
Spring.

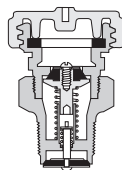

7547B-50  
Body; Gaskets;  
Seat disc & stem assy;  
Spring.

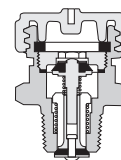

7647B-80  
Gaskets;  
Seat disc & stem assy;  
Spring.

7579-80  
Gaskets;  
Seat disc & stem assy;  
Spring.

7547B-80  
Gaskets;  
Seat disc & stem assy;  
Spring.

**Vapor Return Repair Kits & Contents**

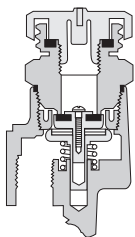

2418-51  
Body; Gasket;  
Seat disc & stem assy;  
Spring; Washer.

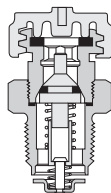

7573D-81  
Note tapered seat.  
Gaskets;  
Seat disc assy.

**8475-51A, 8475-81A**

Old style flat seated valves require  
8475-51A with body.

8475-51A (with body)  
Body, Gaskets, Seat assy, Spring

8475-81A (less body)  
Gaskets, Seat assy, Spring

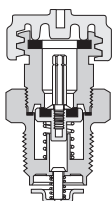

7573A-81  
Note flat seat.  
Gaskets;  
Seat disc assy.

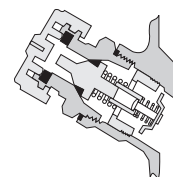

New Style  
Tapered Seat

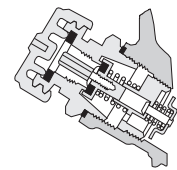

Old Style  
Flat Seat

**Shutoff Repair Kits & Contents**

**19100 Series Repair Options**

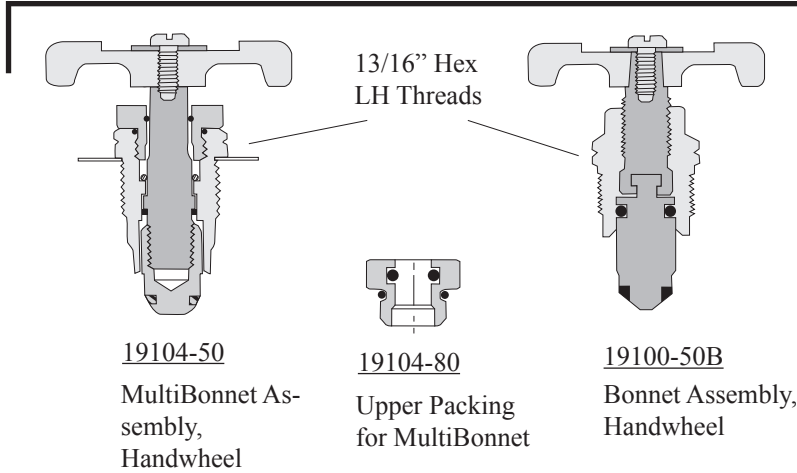

**8100 Series**

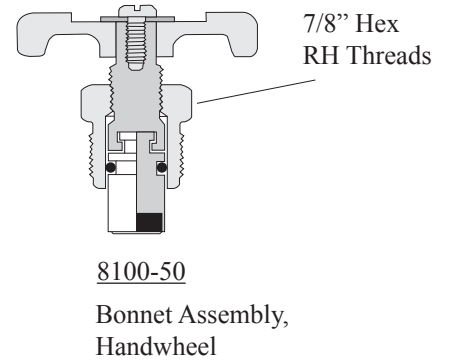

**3100 Series Repair Options**

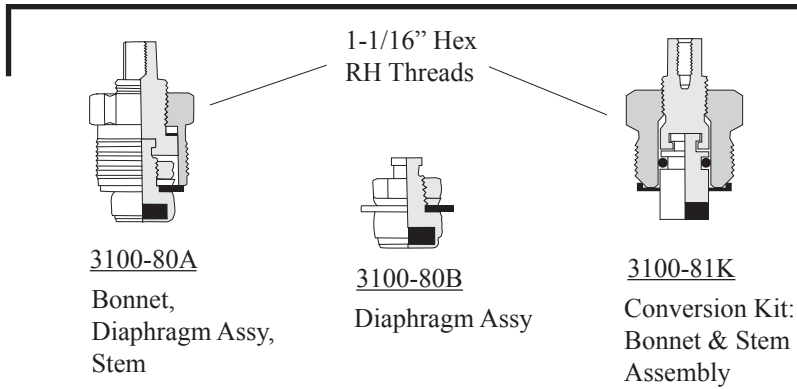

**903 Series**

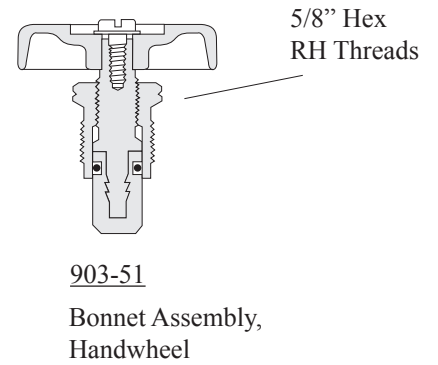

**2100 Series**



2100-25R  
Reference only.  
Kit is obsolete.

**7128-5**

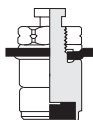

7128-5  
Repairs the 7128  
Horizontal Railroad Valve

**7130BR Repair Options**

Repairs the 7130BR  
John Deere Tractor Valve

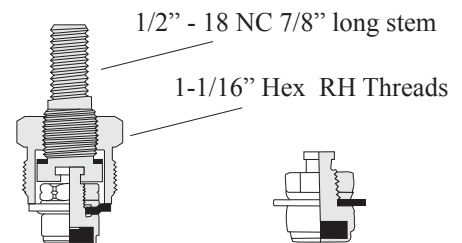

7130BR-1  
Bonnet Assembly

3100-80B  
Diaphragm Assy



**STD Globe and Angle Valve Repair Kits**

Valve Number	Valve Size	Kit Number	Kit Contents
A7505AP	3/4"	A7505-50	Gaskets; jam ring; O-ring; pressure seal rings; seat disc; washer
		7505A-20	Complete bonnet assembly
A7507AP A7508AP	1"	A7507-50	Gaskets; jam ring; O-ring; pressure seal rings; seat disc; washer
		7507A-20	Complete bonnet assembly
A7509BP A7510BP	1-1/4"	A7509-50	Gaskets; jam ring; O-ring; pressure seal rings; seat disc; washer
		7509B-20	Complete bonnet assembly
A7511AP A7511FP A7512AP A7512FP	1-1/2"	A7511-50	Gaskets; jam ring; O-ring; pressure seal rings; seat disc; washer
		7511A-20	Complete bonnet assembly
A7513AP A7513FP A7514AP A7514FP	2"	A7513-50	Gaskets; jam ring; O-ring; pressure seal rings; seat disc; washer
		7513A-20	Complete bonnet assembly
A7517AP A7517FP A7518AP A7518FP	3"	A7515-50	Gaskets; jam ring; O-ring; pressure seal rings; seat disc; washer
		A7515-20	Complete bonnet assembly

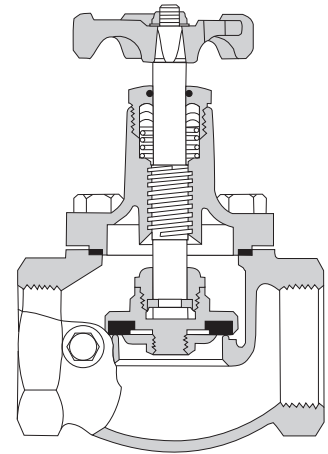

**A7513AP**

**Compact Globe and Angle Valve Repair Kits**

Valve Number	Valve Size	Kit Number	Kit Contents
7704LP 7704P A7704LP A7704P	1/2"	A7705-50	Gaskets; flange packing; friction washer; seat disc
7705P 7706P A7705P A7706P	3/4"	A7705-50	Gaskets; flange packing; friction washer; seat disc

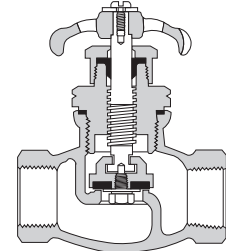

**A7705P**

**Quick Acting Valve Repair Kits**

Valve Number	Valve Size	Kit Number	Kit Contents
7901T 7901TA 7901TB 7901TC	1/2"	7901T-80	Gasket; O-ring; seat retainer assembly
		7901T-50	Bonnet assembly; gasket; lever
7554L Series	1/2" & 3/4"	A7705-50	Gaskets; flange packing; friction washer; seat disc
		7554L-20	Bonnet assembly
7554S Series	1/2" & 3/4"	A7705-50	Gaskets; flange packing; friction washer; seat disc
		7554S-20	Bonnet assembly
A7707L A7708L	1"	A7707-50	Gasket; groove pin; jam ring
		A7707-75	Bonnet assembly

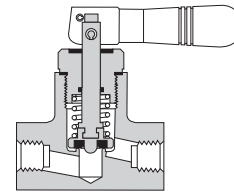

**7901T**

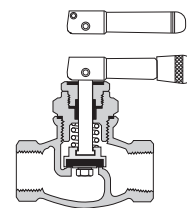

**7554L(S)**

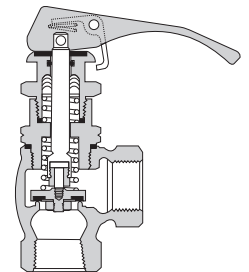

**A7708L**

**Minimum Loss Quick Acting Valve Repair Kits**

Valve Number	Valve Size	Kit Number	Kit Contents
A7797	1"	A7797-50	Gaskets; jam ring; O-ring; pressure seal rings; seat disc; washer
		A7797-75	Bonnet assembly; gasket; lever
		A7797-10M	Lower ACME handle assembly
A7797A	1"	A7797-50	Gaskets; jam ring; O-ring; pressure seal rings; seat disc; washer
		A7797A-4	Bonnet assembly; gasket; lever
		A7797-10M	Lower ACME handle assembly

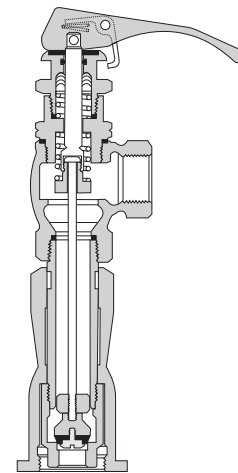

**A7797A**

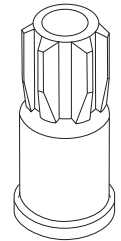

**A7797-10M**

**Internal Valve Repair Kits**

Valve Number	Valve Size	Kit Number	Kit Contents
A3209A	1-1/4"	A3209A-50	Bearing; cam; gasket; main seat disc assembly; retaining ring; seal O-ring; seat disc
A3209D050 A3209D080	1-1/4"	A3209D-50	
A3209R050 A3209R080	1-1/4"	A3209R-50	
A3210A065	1-1/4"	A3210A-50	Bushing; gasket; jam ring; main set disc assembly; upper and lower retaining rings; O-ring; seal rings; seat disc
A3212A Series	2"	A3212A-50	Bearing; cam; gasket; O-rings; seat disc; stem packing
A3212R Series A3212T Series	2"	A3212R-50	
A3213A Series A3213T Series	3"	A3213A-50	
A3217F Series	3"	A3217F-50	Dust seal; jam ring; stem O-ring; stem seals; stem spring; stem washer
		A3217F-80G (Gasket flange)	Dust seal; inner stem bearing; jam ring; lower flange seal gasket; main seat disc; outer stem bearing; pilot seat disc; poppet seal O-ring; retaining ring; roll pin; seat O-ring; stem O-ring; stem seals; upper flange seal gasket; wear button
A3219F Series	4"	A3219F-80G (Gasket flange)	Bumper; cotter pins; dirt seal; inner and outer stem bearings; lever release spring; main seat disc; poppet seat disc; pivot pin locknut; poppet bearing; seal gland gasket; seat seal O-ring; stem jam ring; stem O-ring; stem O-ring; stem seal rings; stop screw; upper and lower flange seal gaskets
A3219FA		A3219FA-80G (Gasket flange)	Bumper; cotter pins; dirt seal; inner and outer stem bearings; lever release spring; main seat disc; poppet seat disc; pivot pin locknut; poppet bearing; seal gland gasket; seat seal O-ring; stem jam ring; stem O-ring; stem O-ring; stem seal rings; stop screw; upper and lower flange seal gaskets

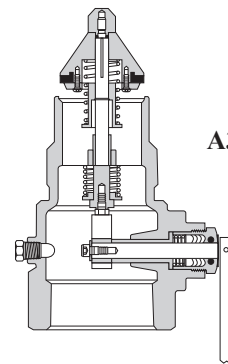

**A3213R**

**A3217FR**

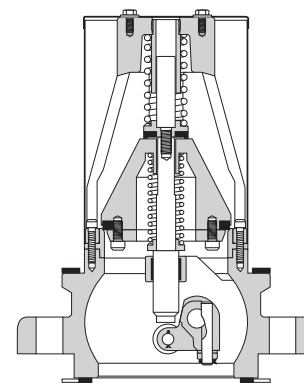
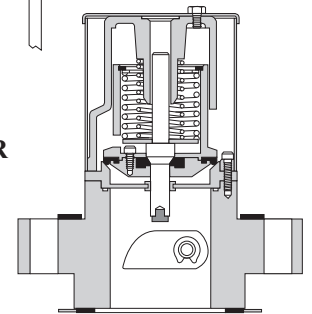

**A3219FA**

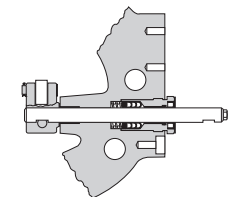

**Stem Packing**

### Flomatic Valve Repair Kits

Valve Number	Valve Size	Kit Number	Kit Contents
A7883F A7884 A7884F	3" & 4"	A7883F-50 (Rebuilding kit)	Stem assembly kit; bleeder assembly; cylinder cap screws; upper and lower piston cap screws; lock washers; filters; springs; block vee packing; X-seal; gaskets; O-rings; retaining ring; insert roll pin; screw seal; cap
A7883F	3"	A7883F-80 (Soft parts kit)	Retaining ring; set disc; insert; block vee packing; filters; X-seals; cylinder cap screws; O-rings; gaskets
A7884F	4"	A7884F-80 (Soft parts kit)	
A7883F	3"	A7883F-150 (Gasket & Seal Kit)	X-seal, seat disc; gaskets
A7884F	4"	A7884F-150 (Gasket & Seal Kit)	

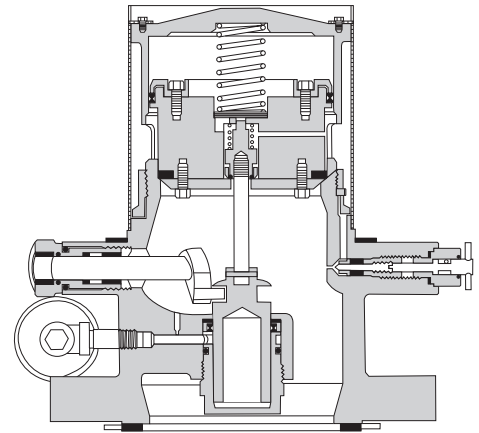

A7884FK

### Flomatic Valve Spare Parts

Valve Number	Valve Size	Kit Number	Description
A7883F	3"	A7883-29	Upper flange gasket
		A7883-30	Lower flange gasket
A7884F	4"	7884-29	Upper flange gasket
		7565-48	Lower flange gasket
A7883F & A7884F	3" & 4"	A7883F-45	Bleeder assembly
		7560-56	Studs, solid, flomatic to tank
		A7884F-43	Studs, hollow, flomatic to pump
		A7884-201	Filter



A7883F-45

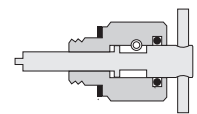

A7884-60

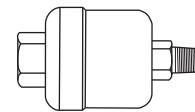

A7884-201



A7884F-43

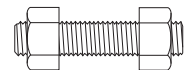

7560-56

### Duoport & Multiport Kits

Valve Number	Valve Size	Kit Number	Kit Contents
8542Series AA8542 Series	2"	8540-50	Bleeder valve assemblies; packing gland; set screw; washer; gasket; key
A8560 Series A8570 Series	3" & 4"	8560-50	Bleeder valve assemblies; seat ring assemblies; pressure seal rings; packing gland; jam ring; washer; gasket
A8560 Series	3"	7564-48	Flange gasket
A8570 Series	4"	7565-48	Flange gasket
ALL	All	8560-26TP	Bleeder valve assembly

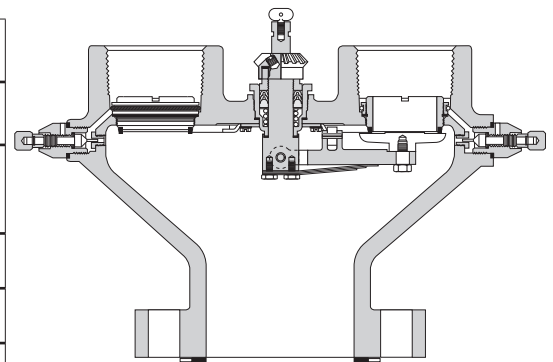

A8564G