

RESIDENTIAL ELECTRIC WATER HEATER OWNER'S MANUAL INSTALLATION AND OPERATING INSTRUCTIONS

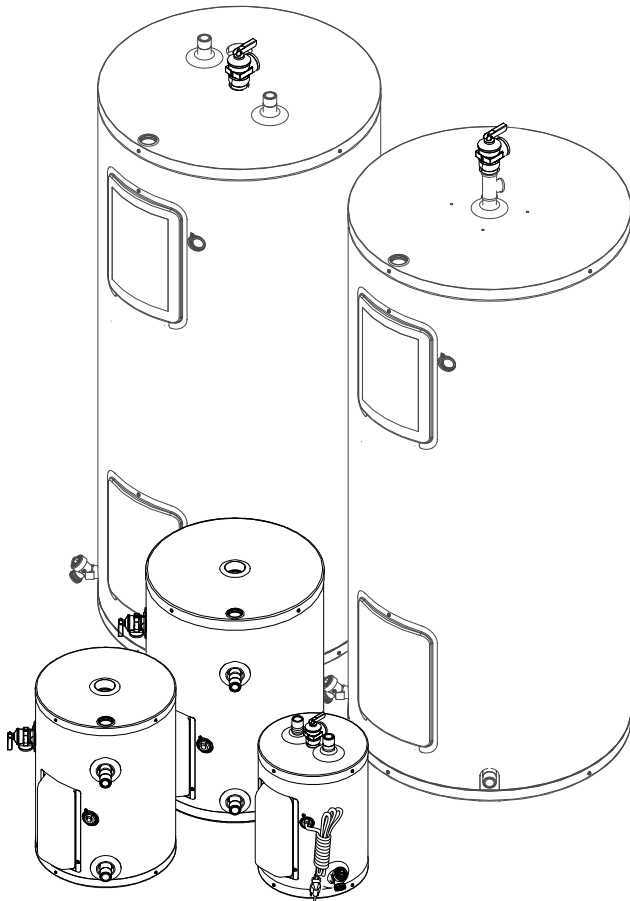

DANGER

If the information in these instructions is not followed exactly, a fire or explosion may result causing property damage, personal injury, or death.

- **DO NOT REMOVE** the element and thermostat access door before the power to the water heater is turned “OFF”.
- **DO NOT ATTEMPT** to repair or replace any of the electrical components installed on the water heater before the power to the water heater is turned “OFF”.
- **DO NOT USE** the water heater on a voltage other than that specified on the water heater rating plate.
- **DO NOT CONNECT** the power supply wiring to anywhere other than the main power connection on the water heater.
- **DO NOT TURN ON** the power to the water heater unless it is completely filled with water.
- **DO NOT DRAIN** the water heater unless the power to the water heater has been turned “OFF”.
- **DO NOT STORE** or use gasoline or other flammable vapours and liquids in the vicinity of this or any other appliance.

WHAT TO DO IF YOU SMELL SMOKE

- Immediately turn “OFF” the power to the water heater.
- If after turning “OFF” the power the smoke continues, call your local fire department.
- When the smoke has stopped, call a qualified service technician to identify and repair the problem.

IMPORTANT

READ THESE INSTRUCTIONS CAREFULLY BEFORE BEGINNING THE INSTALLATION. PROPER INSTALLATION WILL PROVIDE SAFE AND EFFICIENT SERVICE, AND AVOID NEEDLESS EXPENSE NOT COVERED BY THE WARRANTY. READ THE PRODUCT WARRANTY CONTAINED IN THIS MANUAL AND REMEMBER TO FILL OUT AND RETURN TO THE MANUFACTURER ALL RELEVANT WARRANTY CARDS AND CERTIFICATES. SHOULD YOU HAVE ANY QUESTIONS, PLEASE CONTACT YOUR LOCAL DEALER OR REFER TO THE **GETTING SERVICE FOR YOUR WATER HEATER** SECTION OF THIS MANUAL.

SAVE THIS MANUAL FOR FUTURE REFERENCES.

For your records, write the model and serial number here:

Model # _____

Serial # _____



TABLE OF CONTENTS

Safety Information	2	Water Temperature Regulation	9
Installation Instructions	3	General Maintenance	9
Location	3	Condensation	9
Water Piping	3	Water Heater Tank.....	9
Temperature & Pressure-Relief Valve	3	Element or Thermostat Replacement.....	9
Pressure Build-up in a Water System.....	3	Temperature and Pressure-Relief Valve	10
Filling the Water Heater	3	Anode	10
Electrical Connections.....	6	Draining the Water Heater	11
Insulation Blankets.....	6	Vacation	11
Installation Checklist	8	Getting Service for your Water Heater	11
Operating Instructions	8	Replacement Parts	12
Starting the Water Heater	8	Troubleshooting Guide	14
Start-up Procedure.....	9	Warranty	16
Safety Controls.....	9		

SAFETY INFORMATION

Your safety and the safety of others is extremely important during the installation, operation, and servicing of this water heater. Many safety-related messages have been provided in this manual and on your water heater. Always read and obey all safety messages. These messages will point out the potential hazard, tell you how to reduce the risk of injury, and tell you what will happen if the instructions are not followed.



This is the safety alert symbol. This symbol alerts you to potential hazards that can kill or hurt you and others. All safety messages will follow the safety alert symbol and either the word “DANGER” or “WARNING”.



DANGER

Serious injury or death can occur if you do not follow the instructions immediately.



WARNING

Serious injury or death can occur if you do not follow the instructions.



WARNING

DO NOT use this water heater if any part has been under water. Immediately call a qualified service technician to inspect the water heater and to replace any part of the control system which has been under water. Failure to follow this instruction can result in property damage, personal injury, or death.

IMPORTANT

These instructions have been written as a guide for the proper installation and operation of your water heater, and the manufacturer of this water heater will not accept any liability where these instructions have not been followed. However, for your safety and to avoid damage caused by improper installation, this water heater must be installed by a Certified Licensed Professional, and meet all local codes or, in the absence of local codes, CSA C22.1 Canadian Electrical Code, in Canada, and/or the National Electrical Code, ANSI/NFPA 70, in the United States.

Before proceeding with the installation instructions:

- 1) Inspect the water heater and its component parts for possible damage. **DO NOT** install or attempt to repair any damaged component parts. If you detect any damage, contact the dealer where the water heater was purchased or the manufacturer listed on the warranty card.
- 2) Verify that the voltage being supplied corresponds to that which is marked on the water heater rating plate.

INSTALLATION INSTRUCTIONS

Location

This water heater should be located as close as possible to a power supply and to the main use of hot water. This location must not be subject to freezing temperatures. The water heater should be positioned so that the element and thermostat access doors can be removed for inspection, adjustment, and servicing of the elements and thermostats. The drain valve must also be accessible. The water heater must be located close to a suitable free-flowing floor drain. Where a floor drain is not adjacent to the water heater, a suitable drain pan must be installed under the water heater (see **Figure 1A or 1B**). This drain pan should be at least four (4) inches (10.2 cm) larger than the diameter of the water heater, and at least one (1) inch (2.5 cm) deep providing access to the drain valve. This pan must be piped to a suitable drain to prevent damage to property in the event of a water leak from the piping, the relief valve, or the water heater.

Sooner or later, all water heaters leak. The manufacturer, based on national building codes has given the necessary advice to prevent damage to the building. Under no circumstances is the manufacturer to be held liable for any water damage in connection with this water heater.

Should this water heater be installed on carpeting, the carpeting must be protected by a wood or metal panel beneath the water heater. This panel must extend at least three (3) inches (7.6 cm) beyond the width and depth of the water heater. Should the water heater be installed in an alcove or closet, the entire floor area must be covered by the panel.

Water Piping

Refer to **Figure 1A or 1B** for a typical installation. Use of this layout should provide a trouble-free installation for the life of the water heater. Before making the plumbing connections, locate the **COLD** water inlet and the **HOT** water outlet. These fittings are both 3/4" N.P.T. male thread. Make sure that the dip-tube is installed in the cold water inlet (**Top entry Models**). Install a shut-off valve close to the water heater in the cold water line. It is recommended that unions be installed in the cold and hot water lines so that the water heater can be easily disconnected, if servicing is required.

When assembling the hot and cold piping, use Teflon™ food grade of pipe joint compound, and ensure all fittings are tight. It is imperative that open flame is not applied to the inlet and outlet fittings, as heat will damage or destroy the plastic lined fittings. **This will result in premature failure of the fittings, which is not covered by the warranty.**

Temperature and Pressure-Relief Valve

WARNING

DO NOT plug the temperature and pressure-relief valve or its discharge line. **DO NOT** remove the relief valve. Make sure the relief valve is properly sized for the water heater. If the relief valve continuously discharges water, call a qualified service technician to correct the problem. Failure to follow these instructions can result in property damage, personal injury, or death.

To protect from excessive pressure and/or temperature, a temperature and pressure-relief valve that meets the requirements of the Standard for Relief Valves and Automatic Gas Shut-Off Devices for Hot Water Supply Systems, CSA 4.4, in Canada, and ANSI Z21.22, in the United States **MUST BE** installed by the installer when it has not been factory installed. The relief valve should have a maximum set pressure that does not exceed the hydrostatic working pressure of the water heater (150 psi = 1,034 kPa) and a BTU/h rating equal to or greater than the input rating,

as shown on the water heater rating plate. It should never be plugged or removed from the opening marked for it on the water heater.

If this relief valve should need to be replaced, use only a new temperature and pressure-relief valve. Never install an old or existing relief valve, as it may be damaged or inadequate for the working requirements of the new water heater. This new relief valve must meet all local codes or, at a minimum, the requirements listed above. Never install another type of valve between the relief valve and the water heater.

A discharge line must be installed into the relief valve. The discharge line:

- Must not be smaller than the outlet pipe size of the relief valve.
- Must not terminate less than six (6) inches (15.2 cm) and not more than twelve (12) inches (30.5 cm) above a floor drain.
- Must not be restricted in any way. Do not thread, cap, or in any way restrict the end of this outlet.
- Must be of a material capable of withstanding 210°F (99°C) without distortion.
- Must be installed to allow complete drainage of the relief valve and discharge line.
- Must terminate at an adequate free-flowing drain.

Pressure Build-up in a Water System

When the water heater operates, the heated water expands creating a pressure build-up. This is a natural function and is one of the reasons for installing a temperature and pressure-relief valve. If the cold water supply line has a built-in water meter, check valve, or pressure reducing valve, a suitable expansion tank must be installed to prevent pressure build-up or water hammer effect, otherwise the warranty is void (see **Figure 1A or 1B**). An indication of pressure build-up is frequent discharges of water from the relief valve. If the relief valve discharges water on a continuous basis, it may indicate a malfunction of the relief valve, and a qualified service technician must be called to have the system checked, and the problem corrected.

Filling the Water Heater

WARNING

NEVER operate the water heater unless it is completely filled with water. Failure to follow this instruction can result in premature failure of the water heater and its component parts that is not covered by the warranty.

Check that all of the water piping connections have been made. To fill the water heater:

- 1) Make sure that the water heater drain valve is closed by inserting a flat head screwdriver into the slot on the head of the drain valve and turning the knob clockwise .
- 2) Open the cold water supply manual shut-off valve. This valve must remain open, as long as the water heater is in use. **NEVER** operate the water heater with the cold water supply manual shut-off valve closed.
- 3) To make sure the water heater is completely filled with water, open all of the hot water faucets in the house to let the air out of the water heater and plumbing system. Leave the faucets open until a constant flow of water is obtained.
- 4) Check all of the plumbing connections to make sure there are no leaks.

INSTALLATION INSTRUCTIONS

Figure 1A

Models with one (1) element, top entry

ID No.	Description
1)	Hot water outlet
2)	Union
3)	Hot water manual shut-off valve
4)	Temperature & pressure-relief valve
5)	Combination outlet nipple/ Magnesium anode
6)	Combination thermostat and high limit reset control
7)	Element and thermostat access door
8)	Screw-in element
9)	Drain valve
10)	Free-flowing floor drain
11)	Drain pan
12)	Expansion tank
13)	Dip-tube
14)	Check valve, water meter or pressure reducing valve
15)	Cold water manual shut-off valve
16)	Overflow tube
17)	Union
18)	Cold water inlet

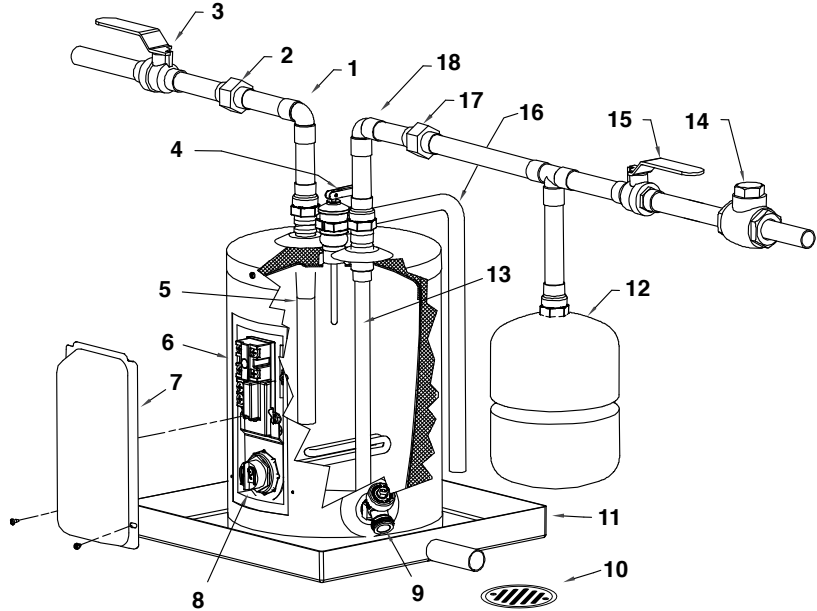

Models with one (1) element, side entry

ID No.	Description
1)	Outlet tube
2)	Temperature & pressure-relief valve
3)	Overflow tube
4)	Magnesium anode
5)	Combination thermostat and high limit reset control
6)	Screw-in element
7)	Element and thermostat access door
8)	Free-flowing floor drain
9)	Drain valve
10)	Drain pan
11)	Expansion tank
12)	Check valve, water meter or pressure reducing valve
13)	Cold water inlet
14)	Cold water manual shut-off valve
15)	Unions
16)	Hot water outlet
17)	Vacuum breaker
18)	Hot water manual shut-off valve

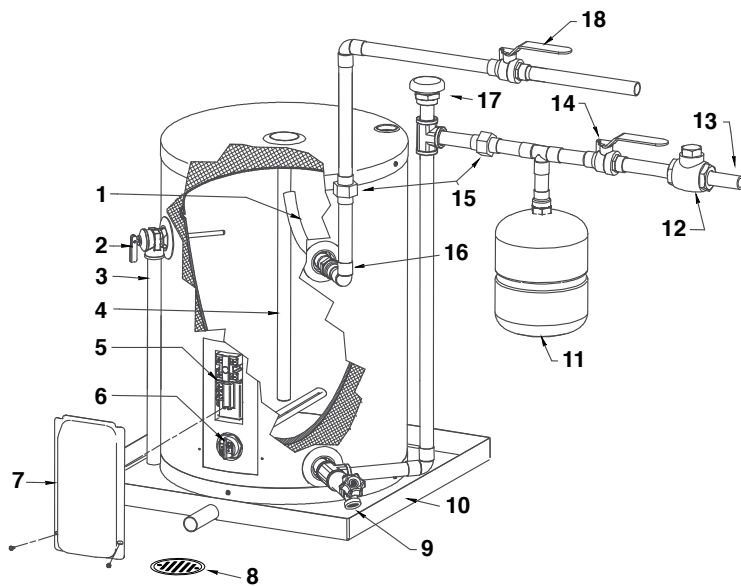

INSTALLATION INSTRUCTIONS

Figure 1B

Models with two (2) elements, top entry

ID No.	Description
1	Check valve, water meter or pressure reducing valve
2	Cold water manual shut-off valve
3	Union
4	Cold water inlet
5	Temperature & pressure-relief valve
6	Expansion tank
7	Overflow tube
8	Dip-tube
9	Drain pan
10	Free-flowing floor drain
11	Lower element
12	Drain valve
13	Element and thermostat access doors
14	Lower thermostat
15	Magnesium anode
16	Upper element
17	Combination upper thermostat and high limit reset control
18	Hot water outlet
19	Union
20	Hot water manual shut-off valve

Screw-in type element

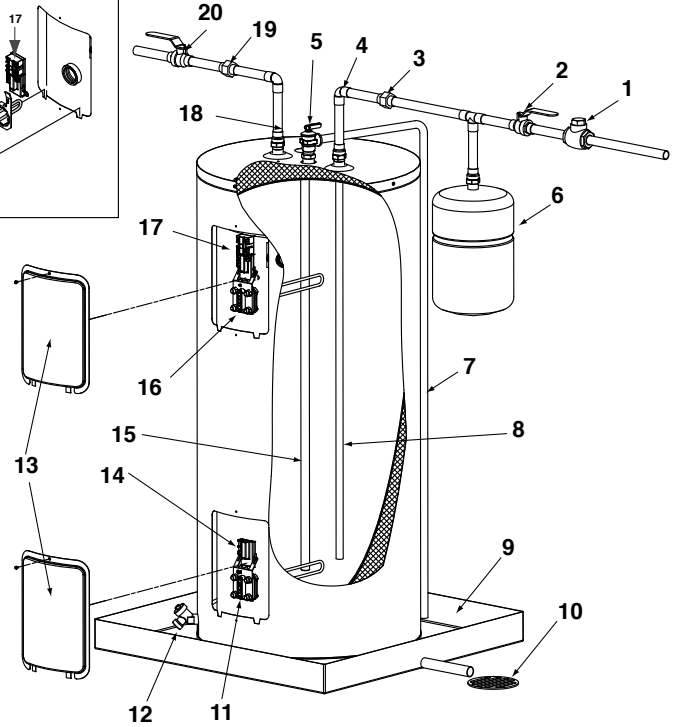
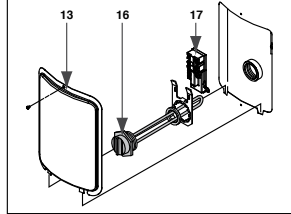

Models with two (2) elements, bottom entry

ID No.	Description
1	Check valve, water meter or pressure reducing valve
2	Cold water manual shut-off valve
3	Union
4	Vacuum breaker
5	Temperature & pressure-relief valve
6	Expansion tank
7	Overflow tube
8	Drain pan
9	Free-flowing floor drain
10	Cold water inlet
11	Lower element
12	Drain valve
13	Element and thermostat access doors
14	Lower thermostat
15	Magnesium anode
16	Upper element
17	Combination upper thermostat and high limit reset control
18	Hot water outlet
19	Union
20	Hot water manual shut-off valve

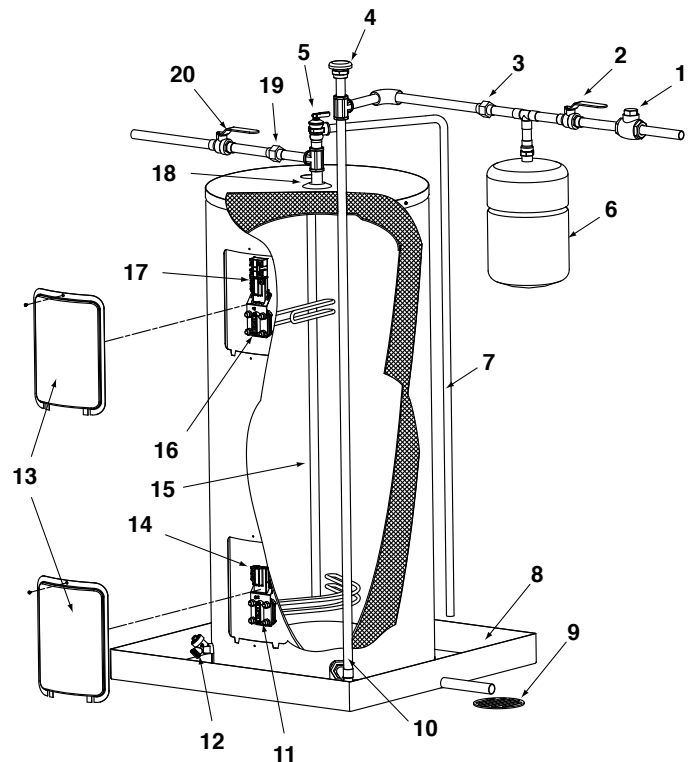

INSTALLATION INSTRUCTIONS

Electrical Connections

⚠ WARNING

This water heater uses an external electrical source for power. It must be electrically grounded in accordance with all local codes or, in the absence of local codes, CSA C22.1 Canadian Electrical Code, in Canada, and/or the National Electrical Code, ANSI/NFPA 70, in the United States. Failure to properly ground this water heater can result in property damage, personal injury, or death.

This water heater must be connected on a separate fuse branch circuit. Check the water heater rating plate for the element wattage and voltage and make sure that the power supply wiring and the fusing or circuit breaker are the correct size for this water heater (see Table 1). Verify that all of the wire connections on the element and thermostat have been installed correctly, are secure, and that none of the wires are grounded, have split, or are broken (see Figure 2A, 2B or 2C). If any of the original wiring needs replacing, use only 14AWG-type, or greater wire that is approved for 221°F (105°C).

To hook-up the water heater to the power supply, connect the power supply wiring to the red and black wires attached to the top thermostat (see Figure 2A, 2B or 2C). **NEVER CONNECT THE POWER SUPPLY DIRECTLY ONTO THE THERMOSTAT.**

Insulation Blankets

⚠ WARNING

The manufacturer's warranty does not cover any damage or defect caused by installation, attachment, or use of any type of energy saving or other unapproved devices (other than those authorized by the manufacturer) into, onto or in conjunction with the water heater. The manufacturer will not accept any liability for loss or injury resulting from the use of such unauthorized devices. The use of unauthorized energy saving devices may shorten the life of the water heater and may result in property damage, personal injury, or death.

Insulation blankets for external use on electric water heaters are not necessary. The purpose of an insulation blanket is to reduce the standby heat loss associated with the operation of storage tank water heaters. This water heater meets or exceeds the NRCAN standards with respect to insulation and standby loss requirements making an insulation blanket unnecessary.

If local codes require the application of an external insulation blanket to this water heater, pay careful attention to the following so as not to restrict the proper function and operation of the water heater:

DO NOT cover the operating or warning labels attached to the water heater or attempt to relocate them on the exterior of insulation blanket.

DO NOT cover the element and thermostat access door or temperature and pressure-relief valve.

Inspect the insulation blanket frequently.

Table 1

Element Wattage	Recommended wire and breaker size					
	Recommended Wire Size*			Recommended Breaker Size		
	120V	208V	240V	120V	208V	240V
1,500 W	#12	#14	#14	20A	15A	15A
3,000 W	#10	#12	#12	30A	20A	20A
3,800 W	---	#10	#12	---	25A	20A
4,500 W	---	#10	#10	---	30A	25A
6,000 W	---	---	#8	---	---	40A

* Should conform to Local Codes.
The water heater must be grounded.

Figure 2A

Models with one (1) element, top entry

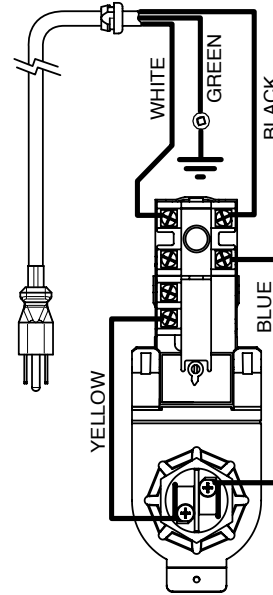

Models with one (1) element, side entry

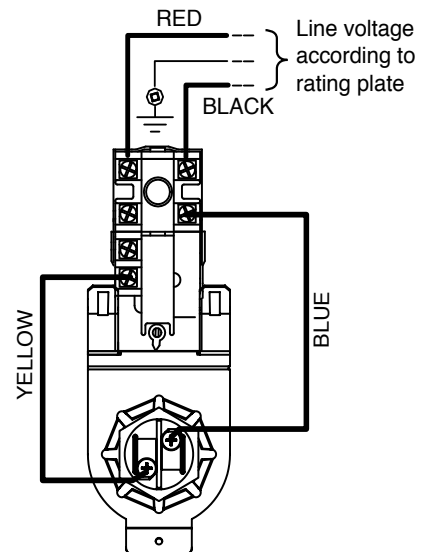

INSTALLATION INSTRUCTIONS

Figure 2B

Models with two (2) elements - square flange and TWIST-LOCK type

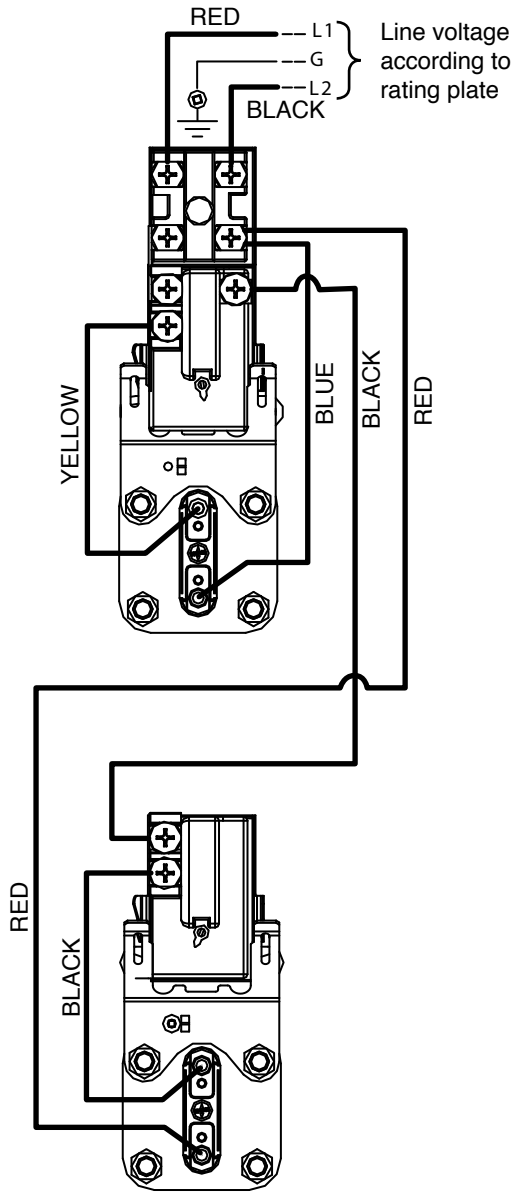
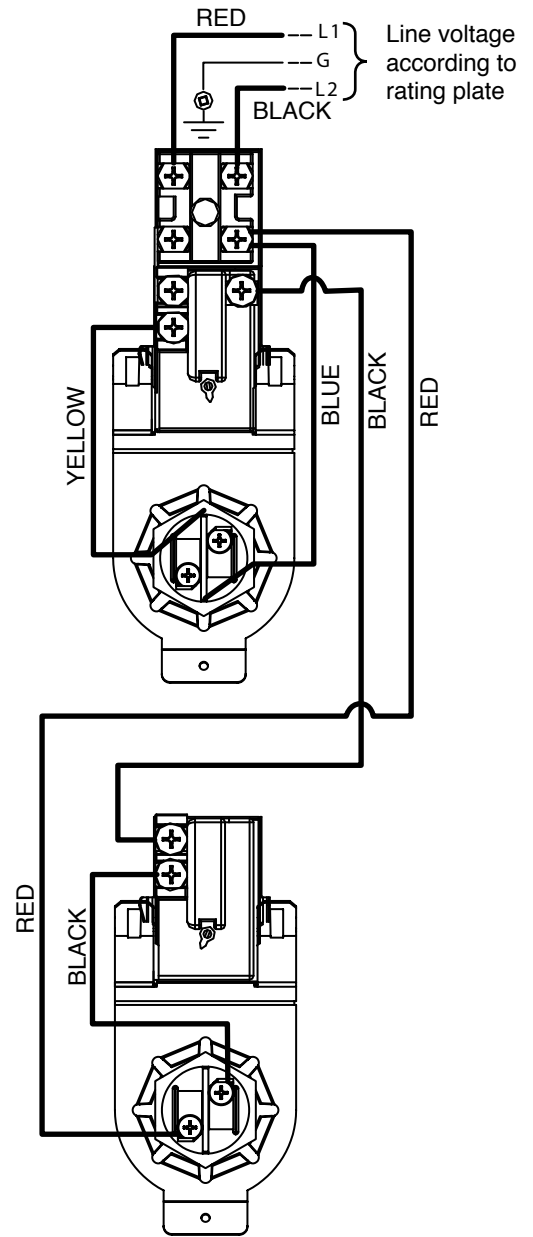

Figure 2C

Models with two (2) elements - screw-in type



OPERATING INSTRUCTIONS

Installation Checklist

Location

- Is the water heater located close to a power supply and the main use of hot water?.....
- Is the water heater protected from freezing temperatures?
- Has a drain pan been installed and piped to a free-flowing drain?.....
- Can the element and thermostat access doors be removed for inspection, adjustment and servicing of the elements and thermostats?
- Is the area where the water heater is located free of flammable vapours?.....

Water Piping

- Is the dip-tube installed in the cold water inlet (ETE Model)?.....
- Has a temperature and pressure-relief valve been installed?
- Does this valve have a discharge line installed, and is it piped to a free-flowing drain?.....
- Have all the plumbing connections been properly installed, and are they leak free?.....
- Is the water heater completely filled with water?

Wiring

- Does the power supply voltage match the voltage indicated on the water heater rating plate?.....
- Has the correct size of wire and fusing or circuit breaker been used to supply the water heater with power?.....
- Is the water heater electrically grounded?
- Have the electrical connections been checked, and are they secure?.....



Starting the Water Heater

Before turning on the power to your water heater, make sure that you have read and understood all of the instructions and warnings in this manual and on your water heater. If you have any questions about turning on your water heater, immediately contact a qualified installer, service agency, or the local electric utility.

WARNING

DO NOT turn "ON" the power to this water heater if:

- It is not completely filled with water.
- The power supply voltage does not match the voltage listed on the rating plate.
- Gasoline or other flammable vapours and liquids have been stored in the vicinity of the water heater.

Failure to follow these instructions can result in property damage, personal injury, or death.



DANGER

If the information in these instructions is not followed exactly, a fire or explosion may result causing property damage, personal injury, or death.

- **DO NOT REMOVE** the element and thermostat access door before the power to the water heater is turned "OFF".
- **DO NOT ATTEMPT** to repair or replace any of the electrical components installed on the water heater before the power to the water heater is turned "OFF".
- **DO NOT USE** the water heater on a voltage other than that specified on the water heater rating plate.
- **DO NOT CONNECT** the power supply wiring to anywhere other than the main power connection on the water heater.
- **DO NOT TURN ON** the power to the water heater unless it is completely filled with water.
- **DO NOT DRAIN** the water heater unless the power to the water heater has been turned "OFF".
- **DO NOT STORE** or use gasoline or other flammable vapours and liquids in the vicinity of this or any other appliance.

WHAT TO DO IF YOU SMELL SMOKE

- Immediately turn "OFF" the power to the water heater.
- If after turning "OFF" the power the smoke continues, call your local fire department.
- When the smoke has stopped, call a qualified service technician to identify and repair the problem.

GENERAL MAINTENANCE

Start-up Procedure

- 1) Turn on the circuit breaker at the main service panel.
- 2) Make sure the fuse box or power switch (if one exists) next to the water heater is pushed to "ON".
- 3) If you smell smoke, refer to **What to do if you smell smoke**.
- 4) Wait one (1) hour. At this time, hot water should be available at the faucet.
- 5) If after one (1) hour you do not have any hot water, check that the fuse or circuit breaker is in working condition.
- 6) Wait another hour. If at this time you still do not have any hot water, call a qualified service technician.

Note: If after one (1) hour you receive only a small amount of hot water, check that the plumbing connections are not reversed.

Safety Controls

This water heater is equipped with a combination thermostat and high limit reset control (ECO) that is located above the upper heating element. If for any reason the temperature of the water becomes excessively high, the ECO will break the power circuit to the heating element. Once the control opens, it must be reset manually.

To reset the ECO:

- 1) Turn "OFF" the power to the water heater.
- 2) Remove the upper element and thermostat access door and the insulation.
- 3) Press the red **RESET** button.
- 4) Replace the insulation and the element and thermostat access door before turning "ON" the power to the water heater.

Water Temperature Regulation

WARNING

The higher the setting, the greater the risk of scalding. Hot water can cause third degree burns in under one (1) second at 160°F (71°C), in six (6) seconds at 140°F (60°C), and in thirty (30) seconds at 130°F (54°C). In households where there are children, physically challenged individuals, or elderly persons, mixing valves for point of use are necessary as means of reducing the scalding potential of hot water.

The thermostat is factory set at 140°F (60°C) for Canadian models and 125°F (52°C) for U.S. models.

To adjust the temperature on the thermostat:

- 1) Turn "OFF" the power to the water heater.
- 2) Remove the element and thermostat access door and the insulation. On U.S. models **DO NOT** remove the thermostat protective cover.
- 3) Using a small flathead screwdriver, turn the thermostat dial to the desired temperature.
- 4) Replace the insulation and the element and thermostat access door before turning "ON" the power to the water heater.

Condensation

Condensation can form on the surface of the water heater:

- 1) When the water heater is filled with cold water for the first time.
- 2) If the water heater has been undersized.
- 3) When large amounts of hot water are drawn from the water heater in a short period of time, and the refill water is very cold.

This condition is not uncommon and must never be misinterpreted as a leaking tank. It will disappear once the water becomes heated.

Because the water can condense, it is very important that a drain pan be installed under the water heater (**refer to Figure 1A or 1B**). **Under no circumstances is the manufacturer to be held liable for any water damage, in connection with this water heater.** If the problem does not go away and water continues to drip after the water heater has heated up, check all of the plumbing connections to make sure they are not leaking.

Water Heater Tank

Drain a pail of water through the drain valve at least once a year. This will remove excess sediment from the bottom of the tank. This sediment, if allowed to accumulate, will reduce the efficiency and the life of the tank.

Element or Thermostat Replacement

WARNING

Before attempting to repair or replace any of the electrical components on this water heater, turn "OFF" the power to the water heater. Failure to do so could result in electrical shock and/or property damage, personal injury, or death.

Replacing an Element (See Figure 3)

- 1) Turn "OFF" the power to the water heater and drain all of the water from the water heater (**see Draining the Water Heater, page 11**).
- 2) Remove the element and thermostat access door and the insulation.
- 3) Disconnect the wires from the element terminals.
- 4) For a square flange element, undo the four (4) bolts securing the element to the water heater.
For a screw-in element, with the help of a 1.5 inch socket wrench, remove the element by unscrewing it from the water heater in a counterclockwise  motion.
For TWIST-LOCK system, unscrew the four (4) bolts securing the element to the water heater and pull element out of the tank. Make sure the TWIST-LOCK flange is in the right position (**See Figure 4**).
- 5) Replace the element with a new element of the same wattage and voltage. Make sure that the gasket surface is clean and that the element has been re-installed water-tight with a new gasket.
- 6) Re-connect the wiring and tighten securely.
- 7) Re-fill the water heater (**see Filling the Water Heater, page 3**). **DO NOT TURN THE POWER ON TO THE WATER HEATER UNLESS YOU ARE SURE IT IS COMPLETELY FILLED WITH WATER.**
- 8) Inspect for any leaks and repair, if necessary
- 9) Replace the insulation and element and thermostat access door before turning "ON" the power to the water heater.

GENERAL MAINTENANCE

Figure 3

Screw-in element

03G, 3AG and 04G Models

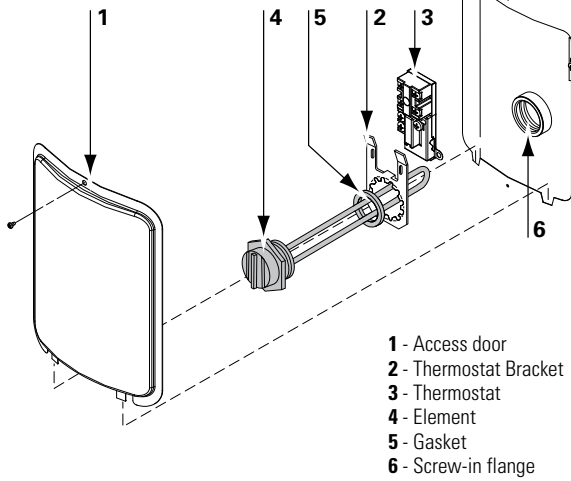

- 1 - Access door
- 2 - Thermostat Bracket
- 3 - Thermostat
- 4 - Element
- 5 - Gasket
- 6 - Screw-in flange

Square flange element

09G, 9AG, 10G, 11G, 12G and 13G Models
(Until December 2012)

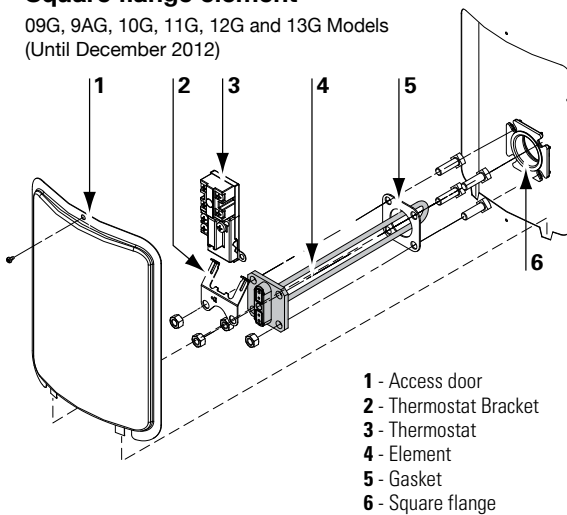

- 1 - Access door
- 2 - Thermostat Bracket
- 3 - Thermostat
- 4 - Element
- 5 - Gasket
- 6 - Square flange

TWIST-LOCK flange element

09G, 9AG, 10G, 11G, 12G and 13G Models

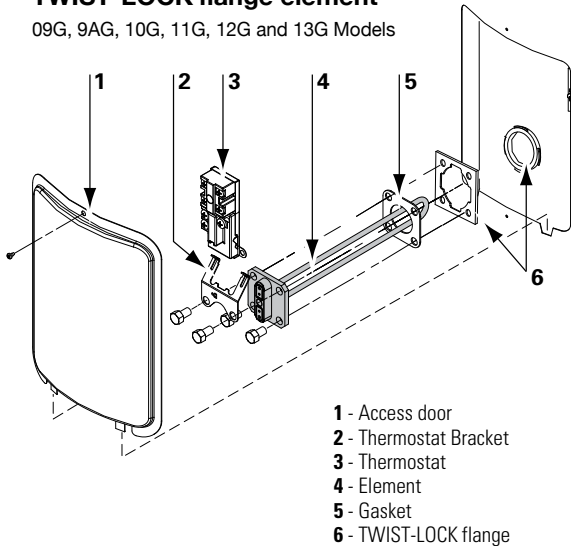

- 1 - Access door
- 2 - Thermostat Bracket
- 3 - Thermostat
- 4 - Element
- 5 - Gasket
- 6 - TWIST-LOCK flange

Figure 4

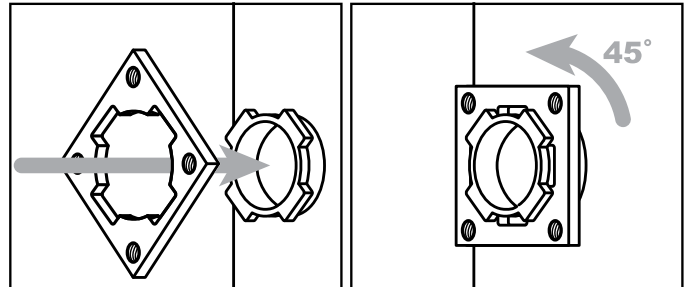

Replacing a Thermostat (See Figure 3)

- 1) Turn "OFF" the power to the water heater.
- 2) Remove the element and thermostat access door and the insulation.
- 3) Disconnect the wires from the thermostat terminals.
- 4) Lift the thermostat bracket arms and slide the thermostat up to remove it.
- 5) Replace the thermostat with a new thermostat of the same manufacturer and type.
- 6) Reconnect the wires on the thermostat terminals referring to the corresponding wiring diagram in **Figure 2**.
- 7) Set the thermostat to the desired temperature (**see Water Temperature Regulation, page 9**).
- 8) Replace the insulation and element and the thermostat access door before turning "ON" the power to the water heater.

Temperature and Pressure-Relief Valve

Manually operate the temperature and pressure-relief valve at least once a year, standing clear of the outlet to avoid being burned. Lift and release the operating lever on the valve to make it operate freely. If, after manually operating the valve, it fails to completely reset itself and continues to discharge water, replace it with a new one.

Anode

This water heater is equipped with an anode that is designed to prolong the life of the glass-lined tank. The anode is slowly consumed, protecting the glass-lined tank from corrosion. The anode should be inspected every two (2) years. If more than half of the anode has been consumed, it should be replaced. Instructions on how to change the anode can be obtained from the manufacturer.

The life expectancy of the water heater is reduced where a water softener is introduced to fight hard water. The sodium salts added by a softener make the water extremely conductive, therefore, the anode are consumed more rapidly. Under these conditions, the anode should be inspected yearly.

In certain water conditions, the anode will react with the water, producing discoloured or smelly water. The most common complaint is hot water that smells like rotten eggs. This phenomenon is the result of the reaction between the magnesium of the anode and hydrogen sulfide gas dissolved in the water, which occurs frequently in well systems. This problem can usually be eliminated or reduced by

GENERAL MAINTENANCE

changing the magnesium anode to a type more suitable for these conditions (aluminum anode) and by chlorinating the water heater and plumbing system. If the problem persists, special filtration equipment may be required. Under no circumstances is the anode to be removed from the water heater on a permanent basis. **Removal of the anode will lead to premature failure of the water heater and void the warranty.**

WARNING

Hydrogen gas can be produced in a hot water system that has not been used for a long period of time (generally two [2] weeks or more). **HYDROGEN GAS IS EXTREMELY FLAMMABLE.** It is highly recommended to open the hot water faucet in the kitchen for several minutes before you use any electrical appliances connected to the hot water system, such as a dishwasher or washing machine. If hydrogen gas is present, there will be an unusual sound, such as air escaping through the pipe, as the hot water faucet is opened. **DO NOT** smoke or introduce an open flame near the faucet when it is opened.

Draining the Water Heater

To completely drain the water heater:

- 1) Turn "**OFF**" the power to the water heater.
- 2) Close the cold water supply manual shut-off valve.
- 3) Connect one end of a garden hose to the water heater drain valve and put the other end next to a free-flowing drain.
- 4) Open the drain valve by inserting a flat head screwdriver into the slot on the head of the drain valve and turning the knob counterclockwise  .
- 5) Open a hot water faucet to allow air into the system.

Vacation

If you are planning a vacation or other prolonged absence, it is highly recommended to turn "**OFF**" the power to the water heater and the cold water supply to the water heater. This will save energy, protect against property damage in the event the water heater leaks, and prevent the build-up of hydrogen gas. If the water heater and piping are exposed to freezing temperatures, they should both be drained. Remember to check the water heater thoroughly after it has been shut off for an extended period of time before putting it back in operation. Make sure that the water heater is completely full of water, and that the cold water supply manual shut-off valve is open, before turning "**ON**" the power to the water heater.

Getting Service for your Water Heater

If you are having problems with your water heater, follow these three easy steps:

- 1) Read the **Troubleshooting Guide** contained in this manual (see **Page 14**). It lists the most common problems experienced with your electric water heater. The solutions you find listed may provide a quick and simple solution to your problem and save you time and money.
- 2) If the solution listed in the **Troubleshooting Guide** does not solve the problem or if your particular problem is not listed in the guide, contact the installer of the water heater, or the local electric utility.
- 3) If you still cannot solve the problem, contact the manufacturer's Customer Service Department by e-mail at service@giantinc.com or by telephone at 1-800-363-9354. To help serve you in a quick and efficient manner, **always have the following information ready:**
 - a) **Model number.**
 - b) **Serial number.**
 - c) **Date of installation.**
 - d) **Where the water heater was purchased.**
 - e) **Complete address where the water heater is installed.**
 - f) **A description of the problem.**

REPLACEMENT PARTS

Figure 5A

Model with one (1) element, top entry

ID No.	Description
1	Combination thermostat and high limit reset control
2	High limit reset control
3	Thermostat
4	Element and thermostat access door
5	Screw-in element gasket
6	Screw-in element
7	Thermostat bracket for screw-in element
8	Drain valve
9	Dip-tube
10	Temperature & pressure-relief valve
11	Combination outlet nipple/Magnesium anode

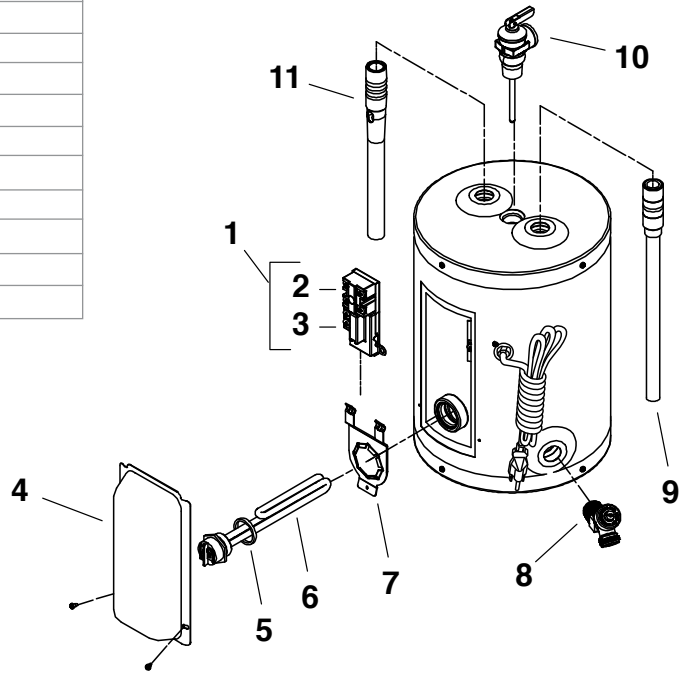

Models with one (1) element, side entry

ID No.	Description
1	Combination thermostat and high limit reset control
2	High limit reset control
3	Thermostat
4	Element and thermostat access door
5	Screw-in element gasket
6	Screw-in element
7	Thermostat bracket for screw-in element
8	Inlet nipple
9	Outlet nipple with tube
10	Magnesium anode
11	Temperature & pressure-relief valve

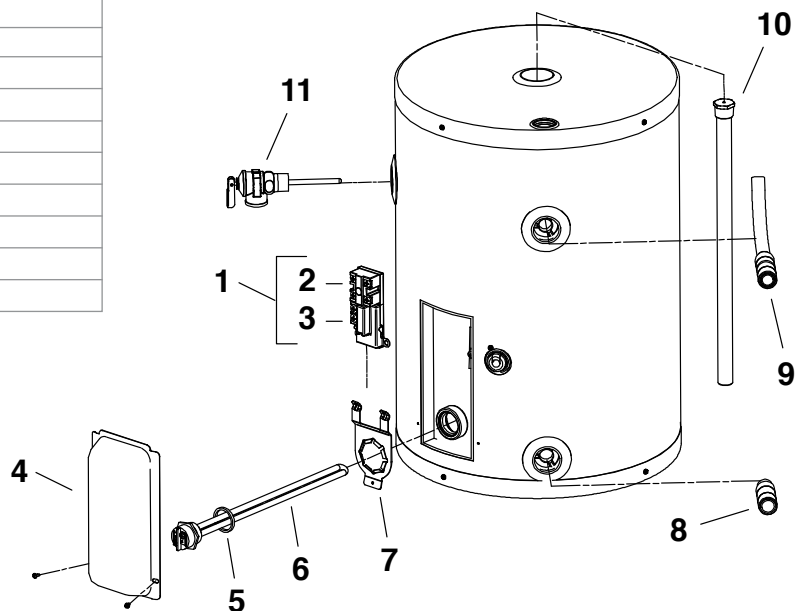

REPLACEMENT PARTS

Figure 5B

Models with two (2) elements, top entry

ID No.	Description
1	Upper thermostat with reset
2a	High limit reset control
2b	Upper thermostat
3	TWIST-LOCK Flanges
4	Element gaskets
5	Upper element
6	Drain valve
7	Lower Thermostat
8	Thermostat brackets
9	Machine bolts
10	Element and thermostat access doors
11	Lower element
12	Dip tube
13	Magnesium anode
14	Extension fitting
15	Outlet nipple
16	Temperature & pressure-relief Valve

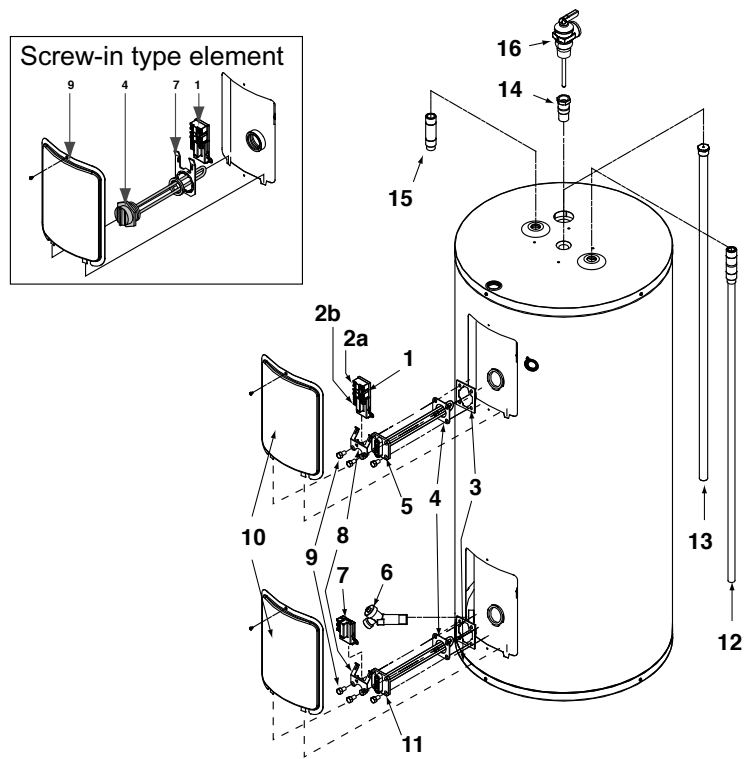

Models with two (2) elements, bottom entry

ID No.	Description
1	Upper thermostat with reset
2a	High limit reset control
2b	Upper thermostat
3	TWIST-LOCK Flanges
4	Element gaskets
5	Upper element
6	Drain valve
7	Lower Thermostat
8	Thermostat brackets
9	Machine bolts
10	Element and thermostat access doors
11	Lower element
12	Inlet nipple
13	Magnesium anode
14	Outlet nipple
15	Brass "T"
16	Temperature & pressure-relief Valve

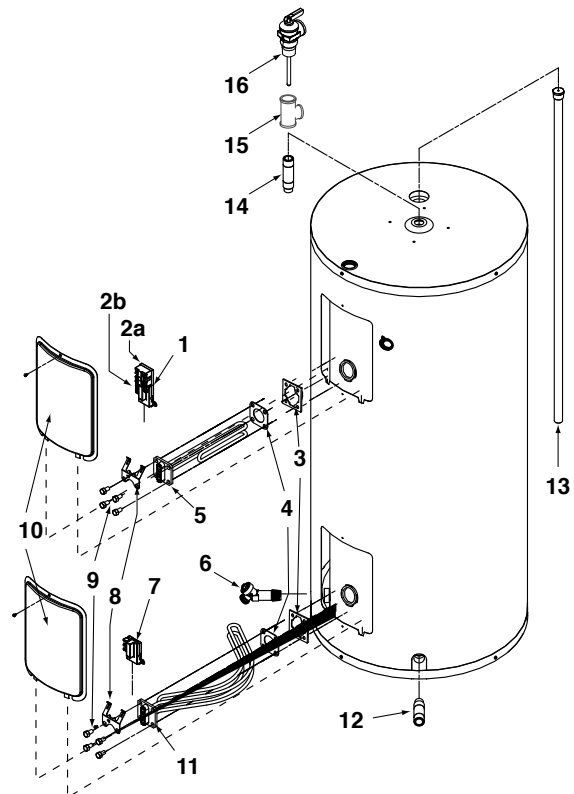

TROUBLESHOOTING GUIDE

CONDITION	CAUSE	REMEDY
No hot water.	Dry-fired element.	Replace with new element.
	Main power supply is "OFF".	Turn "ON" main power supply.
	Burnt fuse.	Replace with new fuse.
	Circuit breaker has tripped.	Reset circuit breaker.
	High limit reset control has tripped.	Reset high limit control by pushing the red reset button.
	Circuit breaker is defective.	Replace with new circuit breaker.
	Defective thermostat.	Replace with new thermostat.
	Defective element.	Replace with new element.
Not enough hot water.	Water heater is undersized.	Install size of water heater that meets demand.
	High hot water demand.	Increase the temperature of the thermostat.
	Very cold water supply.	Increase the temperature of the thermostat.
	Wrong piping connections.	Correct piping.
	Sediment or lime accumulation at bottom of water heater.	Drain water heater. Check to see if water treatment is necessary.
	Hot water plumbing system leaks.	Check hot water plumbing system for leaks and repair.
	Thermostat adjusted too low.	Increase the temperature of the thermostat.
	Defective thermostat.	Replace with new thermostat.
	Defective element.	Replace with new element. In 90% of all cases it is the bottom element.
	Long runs or exposed piping.	Insulate piping.
	Hot water piping on outside wall.	Insulate piping.
	Defective dip-tube.	Replace with new dip-tube.
Boiling hot water.	Thermostat temperature set too high.	Lower the temperature on the thermostat.
	Thermostat not in contact with water heater.	Position properly. Be sure insulation is not interfering with thermostat.
	Element attacked by CO ₂ .	Replace with new element.
	Defective thermostat.	Replace with new thermostat.
Continuous operation.	Water heater is undersized.	Install size of water heater that meets demand.
	Element wattage too small.	Replace with higher element wattage.
	Thermostat not in contact with water heater.	Position properly. Be sure insulation is not interfering with thermostat.
	Thermostat temperature set too low.	Increase the temperature of the thermostat.
	Defective thermostat.	Replace with new thermostat.
	Defective high limit reset control.	Replace with new high limit reset control.
Element failure.	Wiring connections are wrong.	See Figure 2 for correct wiring.
	Wiring connections are loose.	Locate, clean carefully, reconnect properly.
	Lightning/Power surge.	Inspect/replace fuse, element, and thermostat.
	High voltage.	Check with electrical utility and correct.
	Short circuit.	Locate short circuit and repair.
Thermostat failure.	No power.	Inspect fuse/circuit breaker, replace/reset.
	Loose wiring connection.	Locate, clean carefully, reconnect properly.
	Lightning/Power surge.	Inspect/replace fuse, element, and thermostat.
	Low/High voltage.	Check with electrical utility and correct.
	Short circuit.	Locate short circuit and repair.
Blown fuse/circuit breaker.	Wiring connections are wrong.	See Figure 2 for correct wiring.
	Wiring connections are loose.	Locate, clean carefully, reconnect properly.
	Lightning/Power surge.	Inspect/replace fuse, element, and thermostat.
	High voltage.	Check with electrical utility and correct.
	Short circuit.	Locate short circuit and repair.
	Power supply wiring undersized.	See Table 1 for correct wiring size.
Fuse burns instantly.	Short-circuit.	Locate short circuit and repair.

TROUBLESHOOTING GUIDE

CONDITION	CAUSE	REMEDY
Fuse burns often.	Fuse contacts oxidized or fuse not screwed in tight enough.	Clean contacts and tighten fuse.
	Power supply wiring is undersized.	See Table 1 for correct wiring size.
Smoking wiring.	Lightning/Power surge.	Inspect/replace fuse, element, and thermostat.
	Low/High voltage.	Check with electrical utility and correct.
	Power supply wiring undersized.	See Table 1 for correct wiring size.
Service wires charred or hot.	Wiring connections are wrong.	See Figure 2 for correct wiring.
	Water heater not properly grounded.	Properly ground the water heater.
	Lightning/Power surge.	Inspect/replace fuse, element, and thermostat.
	High voltage.	Check with electrical utility and correct.
	Short circuit.	Locate short circuit and repair.
	Power supply wiring undersized.	See Table 1 for correct wiring size.
Drain valve leaks.	Drain valve is open.	Close the drain valve.
	Defective drain valve.	Replace with new drain valve.
Water drips from the relief valve.	Excessive water pressure.	Install a pressure reducing valve.
	Thermal expansion in a closed water system.	Install a suitable expansion tank on the cold water supply line.
	Improperly seated relief valve.	Check relief valve works properly and replace, if necessary.
	Defective thermostat.	Replace with new thermostat.
	Defective relief valve.	Replace with new relief valve.
Water on the floor/drain pan.	Water discharge from the relief valve.	See Pressure build-up in a water system (page 3).
	Element leaks.	Replace with new element.
	Water heater leaks.	Replace with new water heater
Condensation.	Water heater filled for the first time.	Let water heater warm up. Problem should go away. If it persists, check all plumbing connections for leaks.
	Heavy draws of hot water with very cold refill water.	Let water heater warm up. Problem should go away. If it persists, check all plumbing connections for leaks.
	Water heater is undersized.	Install size of water heater that meets demand.
Wet insulation.	Leaking plumbing connections.	Locate leak and repair.
	Leaking around heating element.	Tighten, clean, and smooth face of tank flange and element gasket.
	Water discharge from the relief valve.	See Pressure build-up in a water system (page 3).
Singing element.	Build up of mineral deposits on element.	Clean element, replace with new element if necessary.
Singing thermostat.	Thermostat not flush with tank.	Install thermostat properly.
	Wiring connections are loose.	Locate, clean carefully, reconnect properly.
Traces of rust in the hot water.	Anode has been eaten away.	Replace new anode.
Rusty water.	Water corrosion.	Replace with new water heater.
Rotten egg smell.	High sulfate or mineral content in water.	Change magnesium anode to an aluminum anode and bleach water heater.
Tank bulged.	No relief valve installed.	Install proper relief valve.
	Excessive water pressure.	Install a pressure reducing valve.
	Thermal expansion in a closed water system.	Install a suitable expansion tank on the cold water supply line.

STANDARD BASIC LIMITED WARRANTY ON RESIDENTIAL ELECTRIC WATER HEATERS

GENERAL

The manufacturer warrants that, subject to verification of a warranty claim within the warranty period as described below, it will take the necessary corrective action to either repair or replace a water heater or component part which is determined to be defective in material or workmanship subject to the terms and conditions outlined in this document. Further, any replacement water heater or component part supplied under warranty will carry only the unexpired portion of the original water heater's warranty. The number of replacement water heaters is limited to one (1) per original unit purchased. If due to some extremely unusual circumstance, a replacement water heater or component part is found by our inspection & testing department to be defective, another heater or component part will be supplied to fulfill the obligation of the warranty of the original heater.

THE INNER TANK

If the inner tank fails within SIX (6) years after the date of the original installation, a replacement water heater will be provided to the party from whom the unit was originally purchased. If the water heater is installed in other than a single family dwelling, the tank warranty is limited to ONE (1) year. If an exact replacement is not available, the manufacturer reserves the right to furnish a comparable model water heater; however, a surcharge will be applied for any additional component(s) incorporated in the replacement water heater. The warranty reply card must be completed and sent back to the manufacturer within forty-five (45) days of the installation date. If said warranty card is not returned, the date indicated on the model serial plate will prevail.

COMPONENT PARTS

If any component part is found to be defective within ONE (1) year from the date of original installation, provided said defective part is an in-house factory made piece or an original factory approved OEM piece, the manufacturer will furnish a replacement part after the receipt and testing of the part claimed to be defective.

THIS WARRANTY WILL NOT APPLY

- 1) To defects or malfunctions resulting from failure to properly install, operate, or maintain the unit in accordance with the printed instructions.
- 2) If the installation does not conform to CSA &/or ETL Standards as well as any applicable national or local building codes.
- 3) To any damage or failure caused by abuse, accident, fire, floods, freezing, or other acts of God.
- 4) To any damage or failure caused by operating the heater without an approved temperature and pressure-relief valve having been installed.

- 5) To any damage or failure caused by operating the heater with an empty or partially empty inner tank or sediment build-up resulting in dry firing of the heating elements.

- 6) To any damage or failure caused by utilizing the heater in conjunction with any other energy saving device or other source(s) of energy not approved by the manufacturer; or for other than use with potable water without any additives such as salt, chlorine, or chemicals other than those added for the purpose of rendering the water fit to drink.

- 7) To any damage or failure caused by the removal of the anode &/or by not assuring that there is a working anode in the tank at all times. All anodes must be checked at least once every two (2) years & replaced if necessary.

- 8) To any damages or failure caused by having affixed to the heater any non-factory made or factory approved replacement part(s) such as elements, controls, dip-tubes, relief valves, etc.
- 9) To any damage caused by not having the water heater installed adjacent to a free flowing drain in the event of water leakage.

- 10) If the heater is operated at water temperatures exceeding the maximum setting of the operating &/or high limit control or the heater is not supplied with potable water, free to circulate at all times.

- 11) If the heater has experienced the effect of thermal expansion due to excessive pressure (exceeding 300PSI). The result of excessive pressure usually reverses the bottom of the inner tank and can occur with the addition of a pressure reducing valve &/or a check valve in the municipal water supply system in a single family dwelling.

- 12) If the heater is installed outside of Canada or the United States.

SERVICE LABOUR RESPONSIBILITY

This warranty does not cover any labour expense for service, removal, or re-installation of a replacement heater. All such expenses are your responsibility.

SHIPPING COSTS

If a water heater or component part is deemed to be replaced, the manufacturer will pay the transportation costs of the replacement unit to a convenient authorized distributor or retailer as selected by us. You must pay any local cartage including the cost of returning the replaced item to the authorized distributor or retailer from whom the replacement is coming from.

HOW TO MAKE A CLAIM

Any claim for warranty service should be made to your contractor, wholesaler, or retailer from whom the water heater was purchased. In turn, said contractor, wholesaler, or retailer will contact the manufacturer from whom they purchased the heater. If this procedure cannot be followed, contact any other local contractor, wholesaler, or retailer handling our water heaters. Also, for warranty information you may call the manufacturer's customer service department at (514) 645-8893 or 1-800-363-9354, Option 1. We suggest that prior to calling the factory, you make sure to have the model & serial number is to be found on the outside casing of the heater. Proof of purchase showing the date, name, and place of business from whom the water heater was purchased is essential to settle any warranty claim dispute over the length of the period of installation.

If an exact replacement is not available, a current model water heater or component part with comparable operating features will be provided by the manufacturer. If government regulations or industry standards require the replacement model water heater or component part to have features not found on the defective model water heater or component part, you will be charged the difference in price associated with these required features. If you pay the difference in price for these required features, you will receive a complete new Standard Basic Limited Warranty for the replacement water heater.

MISCELLANEOUS

No one is authorized to make any other warranties on the manufacturer's behalf. Any implied warranties of any nature offered by a third party other than what is stated in this Standard Basic Limited Warranty will not be honoured. No claims for incidental or consequential damages (including damages from leakage) will be accepted. If you do not return the warranty card, a proof of purchase showing the name, date, and location of the original source of purchase is a necessity to process a warranty claim. Failure to produce this documentation will result in the lesser of the warranty periods being offered. In order to avoid any confusion &/or disputes, we suggest that the warranty card be completed and mailed back no later than forty-five (45) days after installation.

EXTENDED WARRANTIES

For information on some premium quality residential gas & electric water heaters, contact your local licensed plumber, or look for them at selected retailers.