

CLICK ANYWHERE on THIS PAGE to GAS PIPING, FLEXIBLE CSST INFORMATION at [InspectApedia.com](http://InspectApedia.com)

# **BLUEBOOK**

**SPECIFICATIONS AND REQUIREMENTS FOR GAS  
INSTALLATIONS**

**NEW YORK CITY AND  
LONG ISLAND**

**NOVEMBER 2015**



## ***Ensuring a Successful Gas Meter Set***

- ✓ Gas Meter Header has been kept plumb and square
- ✓ Final grade has a minimum clearance of 6" to the bottom of the meter
- ✓ Gas regulator vent maintains 18" minimum height from grade
- ✓ Gas regulator vent meets 18" clearance requirements from windows, doors, other openings into the building
- ✓ Gas regulator vent maintains a minimum of 10' from any mechanical air intakes
- ✓ Gas regulator vent terminus maintains 3' from any source of ignition
- ✓ Gas regulator vent and meter header maintains a minimum of 12" horizontally from any electric meter pans or electric meters
- ✓ Electric meters meet clearance requirements and are not installed directly above the gas regulator or meter header
- ✓ Electric meter has been installed and the dwelling is powered up
- ✓ Customer owned piping has been sleeved or properly cold wrapped for protection if going through a masonry wall
- ✓ Multiple meter header has been properly secured to the wall
- ✓ Multiple meter headers have had ID tags installed identifying the units locations
- ✓ Protection posts shall be installed to code if required to prevent vehicular damage
- ✓ Make up air requirements meet combustion needs
- ✓ City, State, Town, or Village pressure test certificate has been left on site for National Grid if required by the authority having jurisdiction before meter can be set
- ✓ All customer owned piping is installed to National Grids Blue Book requirements, and meets City, State, Local, IFGC code. All CSST products must meet manufacturer's bonding requirements.  
*Check with the authority having jurisdiction to verify the code they are following*
- ✓ National Grid has access to the dwelling to install meter and fire one piece of equipment to obtain Lock Up and Running Pressures

***GAS METER SET APPOINTMENT CONTACT NUMBER***

***New York/Long Island 1-877- MyN-Grid***



## IMPORTANT NOTICE

### REGARDING

### **NATIONAL GRID SPECIFICATIONS AND REQUIREMENTS FOR GAS INSTALLATIONS**

These Specifications and Requirements have been designed with great care so that, when followed consistently, they will ensure that a new installation will comply with New York State law, various codes and other safety requirements. Failure to comply may result in a code or safety *violation* and/or a job not being approved. Therefore, delays could result while the contractor corrects the changes at his/her expense.

The specifications, construction standards and other requirements contained in this book represent National Grid commitment to the contracting community for quality and consistency of service. Any variation from the type of hardware used, connection point of service, service entrance or other details on a construction standard must be approved in advance by National Grid in writing.

We at National Grid are always available to discuss your design concerns and to provide assistance to you. We encourage any questions regarding your problems on specific projects, please be sure to contact us for our input during the *planning* stages to avoid possible additional costs later in the job.

Paul Gugliotta – Materials & Standards/Gas Engineering

Paul Cama - Customer Fulfillment

Peter Polumbo – Policy & Procedures

Clem Sebastopoli – Meter Operations

Richard Stark – Gas Growth Support - Long Island

Tim Restivo – Gas Growth Support

Robert Zabielski - Gas Customer Meter Service

Paul Smith – Gas Growth Support – NY City

Chris Marconi – Gas Customer Meter Services

## TABLE OF CONTENTS

1.0	INTRODUCTION 1	
1.1	PURPOSE.....	1
1.2	SCOPE/REFERENCES.....	1
1.3	EXCLUSIONS; RETROACTIVITY.....	2
1.4	ALTERNATE MATERIALS, EQUIPMENT AND PROCEDURES.....	2
1.5	RESPONSIBILITY .....	2
2.0	DEFINITION OF TERMS.....	2
3.0	GENERAL .....	8
3.1	AREA/GEOGRAPHICAL CONSIDERATIONS .....	8
3.2	COMMUNICATION/COOPERATION .....	9
3.3	MEANING OF " <b>SHALL</b> " IN THIS BOOK .....	9
3.4	STATE AND LOCAL CODES .....	9
3.5	RESPONSIBILITY FOR CODE APPLICABILITY .....	10
3.6	INSPECTIONS, CERTIFICATES, PERMITS .....	10
3.7	ACCESS TO CUSTOMERS' PREMISES .....	10
3.8	IDENTIFICATION OF EMPLOYEES .....	10
3.9	UNAUTHORIZED CONNECTIONS.....	10
3.10	SEALS AND TAMPERING DEVICES.....	10
3.11	DISCONNECTION OF SERVICE .....	10
3.12	REACTIVATING GAS SERVICE FOLLOWING A WARNING TAG VIOLATION .....	11
3.13	NATIONAL GRID EQUIPMENT ON PRIVATE PROPERTY .....	11
3.14	DEMOLITION .....	11
3.15	INTERCONNECTIONS.....	11
3.16	BACK-PRESSURE AND SUCTION PROTECTION.....	11
3.17	PROTECTION WHEN COMPRESSED AIR OR OXYGEN CAN ENTER GAS PIPING.....	12
3.18	ADEQUACY AND SAFETY .....	12
3.19	CODE COMPLIANCE.....	12
3.20	REVISIONS OF THIS BOOK .....	12
4.0	NEW GAS SERVICE INSTALLATION PROCESS.....	13
4.1	GENERAL.....	13
4.2	REQUIREMENTS FOR HAVING A NEW RESIDENTIAL AND SMALL COMMERCIAL GAS SERVICE INSTALLED .....	20
4.3	RUD AND CIPUD SERVICE.....	21
5.0	GAS SERVICE LINE(S).....	25
5.1	GAS SERVICE LINE(S) TO A BUILDING OR OTHER GAS USAGE .....	25
5.2	LOCATION OF GAS SERVICE LINE(S)/LATERAL(S) .....	26

---

5.3	SERVICE ENTRANCE.....	26
5.4	CONNECTION POINT OF SERVICE, BROOKLYN UNION/CUSTOMER CONNECTION POINT OF GAS SERVICE .....	27
5.5	RESTORATION ON PRIVATE PROPERTY.....	27
5.6	ADDITIONAL METERS OR SERVICES.....	27
6.0	GAS PRESSURE.....	27
6.1	NOMINAL METER OUTLET PRESSURE WHEN SERVED FROM BROOKLYN UNION'S HIGH PRESSURE DISTRIBUTION SYSTEM .....	27
6.2	METER OUTLET PRESSURE WHEN SERVED FROM NATIONAL GRID'S LOW PRESSURE DISTRIBUTION SYSTEM .....	28
6.3	PRESSURE AND CONTRACTOR'S PIPING .....	28
6.4	ELEVATED METER OUTLET PRESSURE ON HIGH PRESSURE DISTRIBUTION SYSTEM .....	28
6.5	ELEVATED METER OUTLET PRESSURE ON LOW PRESSURE DISTRIBUTION SYSTEM .....	29
6.6	LOCAL CODES RELATING TO ELEVATED GAS PRESSURES .....	30
7.0	METERS AND REGULATORS.....	30
7.1	PREREQUISITES AND NOTIFICATIONS FOR NEW GAS METERS .....	30
7.2	METER SET LOCATION REQUIREMENTS.....	30
7.3	INSTALLATION AND INTERCONNECTION REQUIREMENTS .....	31
7.4	INDOOR METER SET REQUIREMENTS.....	33
7.5	INDOOR METER SET REQUIREMENTS FOR LARGE INSTALLATIONS.....	33
7.6	MULTIPLE METER HEADER REQUIREMENTS .....	34
7.7	METER SET PROTECTION REQUIREMENTS .....	34
7.8	METER HEADER PAD REQUIREMENTS FOR LARGE GAS INSTALLATIONS .....	35
7.9	WALLS TO SUPPORT METER HEADER REQUIREMENTS .....	35
7.10	RELOCATION OF GAS METER SETS .....	35
7.11	GAS SERVICE REGULATOR AND VENTING REQUIREMENTS.....	36
7.12	METER BYPASS REQUIREMENTS.....	37
7.13	TELEMETERING INSTALLATION REQUIREMENTS .....	37
7.14	METER INSTALLATION, PURGING AND RELIGHTING.....	37
7.15	PILOT GAS SUPPLY FOR INTERRUPTIBLE RATE CUSTOMERS.....	38
8.0	CUSTOMER-OWNED GAS PIPING SYSTEMS .....	38
8.1	GENERAL.....	38
8.2	PIPE SIZING .....	39
8.3	PIPING DRAWING .....	39
8.4	GAS PIPING MATERIALS.....	40
8.4.1	GENERAL.....	40
8.4.2	GAS PIPING MATERIALS, INDOORS .....	40
8.4.3	GAS PIPING MATERIALS, OUTDOORS, ABOVE GROUND .....	41
8.4.4	GAS PIPING MATERIALS, BELOW GROUND, GENERAL .....	41
8.4.5	GAS PIPING BELOW GROUND, STEEL PIPE OPTION.....	41
8.4.6	GAS PIPING BELOW GROUND, PLASTIC PIPE OPTION .....	42
8.4.7	GAS "PIPING" BELOW GROUND, COPPER TUBING OPTION .....	42
8.5	VALVES.....	43
8.6	STEEL GAS PIPING, WELDING REQUIREMENTS .....	43

---

8.6.1	GENERAL.....	43
8.6.2	RESIDENTIAL, COMMERCIAL, INDUSTRIAL, MULTI-FAMILY INSTALLATIONS IN NASSAU AND SUFFOLK COUNTIES .....	37
8.6.3	ALL PUBLIC AND PRIVATE SCHOOL BUILDINGS, INCLUDING COLLEGES .....	43
8.6.4	TESTING REQUIREMENTS OF PIPING AFTER THE METER.....	44
8.6.5	STANDARDS FOR NON MERCURY GAUGE.....	44
8.6.6	WELDER QUALIFICATIONS.....	45
8.7	GAS PIPING (INDOORS AND OUTDOORS) ABOVE GROUND, INSTALLATION REQUIREMENTS, GENERAL .....	45
8.8	GAS PIPING OUTDOORS, BELOW GROUND, INSTALLATION REQUIREMENTS.....	47
8.9	STEEL GAS PIPING , CORROSION PROTECTION REQUIREMENTS, COATING AND WRAPPING .....	48
8.10	STEEL GAS PIPING, CORROSION PROTECTION REQUIREMENTS, INSULATING JOINTS .....	49
8.11	STEEL GAS PIPING, CORROSION PROTECTION REQUIREMENTS, MAGNESIUM ANODES .....	49
8.12	PLASTIC PIPING, INSTALLATION REQUIREMENTS.....	50
8.13	COPPER TUBING INSTALLATION REQUIREMENTS.....	51
8.14	GAS PIPING THROUGH BUILDING WALLS, ABOVE OR BELOW GROUND, INSTALLATION REQUIREMENTS .....	51
8.15	PRESSURE TESTING OF GAS PIPING .....	52
9.0	GAS UTILIZATION EQUIPMENT .....	52
9.1	GENERAL.....	52
9.1.1	APPLIANCES, ACCESSORIES AND EQUIPMENT APPROVAL .....	52
9.1.2	INSTALLING CONTRACTOR'S RESPONSIBILITIES .....	52
9.1.3	CO ALARMS .....	53
9.1.4	ASSEMBLY OF EQUIPMENT .....	53
9.1.5	GAS UTILIZATION EQUIPMENT INSTALLED IN RESIDENTIAL GARAGES.....	53
9.2	NATIONAL GRID " <u>NATURAL GAS PRESSURE, IGNITION &amp; DRAFT TEST</u> " .....	53
9.3	GENERAL REQUIREMENTS, SPACE AND WATER HEATING EQUIPMENT INSTALLATIONS .....	53
9.4	COMBUSTION, DILUTION AND VENTILATION AIR (FRESH AIR) REQUIREMENTS.....	53
9.5	VENTING OF CATEGORY I GAS UTILIZATION EQUIPMENT ONLY .....	54
9.6	VENTING OF GAS UTILIZATION EQUIPMENT - CATEGORIES II, III AND IV .....	54
9.7	CHIMNEYS.....	54
9.8	SPILL SWITCH REQUIREMENTS.....	55
9.9	INSTALLATION OF HEAT PRODUCING EQUIPMENT IN FLAMMABLE OR CORROSIVE ATMOSPHERES .....	55

9.10	GAS CONVERSIONS AND CONVERSION BURNER REQUIREMENTS .....	56
9.11	GAS FIREPLACES (VENTED DECORATIVE GAS APPLIANCES).....	57
9.12	ILLIMINATING DEVICES .....	57
9.13	NATURAL GAS COMBUSTION ENGINES .....	58
9.14	COMPRESSED NATURAL GAS (CNG) STATIONS .....	58
9.15	UNVENTED ROOM HEATERS .....	58
9.16	OTHER EQUIPMEMNT.....	58
9.17	COMBO WATER HEATERS.....	58

## APPENDICES

APPENDIX A	SERVICE REGULATOR VENT PIPING REQUIREMENTS
APPENDIX B	CHOOSING A FURNACE OR BOILER
APPENDIX C	NATIONAL GRID'S NEW METER SET HOTLINE
APPENDIX D	GAS PIPING SYSTEM PRESSURE TESTING REQUIREMENTS AND INSTRUCTIONS
APPENDIX E	CUSTOMER OWNER GAS PIPING INSPECTION CERTIFICATE
APPENDIX F	CORRIGATED ATAINLESS STEEL TUBING
APPENDIX G	NEW YORK STATE CO ALARM LAW RULE
APPENDIX H	PROPERTIES OF NATURAL GAS
APPENDIX I	METER SIZES AND DIMENSIONS
APPENDIX J	FREQUENTLY USED STANDARDS
APPENDIX K	LINKS TO MANUFACTURERS

## **Blue Book PART II – Temperature Controlled Specifications**

## 1.0 INTRODUCTION

### 1.1 PURPOSE

This book presents specifications and requirements relating to the connection and use of natural gas supplied from the National Grid Gas System. It contains the minimum acceptable standards for gas piping and gas appliance installation necessary to ensure the safe and satisfactory utilization of natural gas by our customers. The information contained herein is intended primarily to assist the installer in the new gas installation process, but it is also intended for use by our customers, by architects and engineers, and finally, by people in various departments at National Grid. It shall be used when a customer's gas installation is new, when a customer is increasing gas usage from a smaller capacity, or when any changes are made from the original installation. It represents a collection of information which will provide for a safe, properly conceived, accurately sized and cost effective installation that will give long lasting, satisfactory service to our customers.

### 1.2 SCOPE/REFERENCES

The contents of this book apply to installations connecting gas supply system to a customer's premises. We have made it as comprehensive as is practical, within the limits of the intended overview of the subject matter it addresses. The intent of the book is to provide a framework for the subject, not a collection of specific information from various sources. Generally, it refers to several primary documents which form its basis:

- a. The National Fuel Gas Code (NFPA 54/ANSI Z223.1), latest revision, referred to in the book as NFPA 54.  
**(COVERS CUSTOMER OWNED PIPING AFTER THE GAS METER)**
- b. The New York State Codes, Rules and Regulations Title 19 (16 NYCRR 255 and 261), latest revision, referred to in the book as *NYCRR*.  
**(COVERS UTILITY OWNED PIPING BEFORE THE GAS METER)**
- c. Fuel Gas Code of New York State (FGCNYS)  
**(COVERS CUSTOMER OWNED PIPING AFTER THE GAS METER IN NEW YORK STATE)**
- d. Manual of Planning Standards for School Buildings (NYS Board of Regents)  
**(COVERS ALL NY STATE SCHOOLS, EXCEPT NYC)**
- e. International Fuel Gas Code  
**(COVERS CUSTOMER OWNED PIPING AFTER THE GAS METER)**

It is important to note here that **New York City**, towns, villages, counties, etc., frequently have codes to which the owner or his/her plumbing contractor is expected to adhere. It is *the owner's or installer's responsibility* to become aware of the requirements of the area in which the installation is to take place. The reference to the latest revision of the National Fuel Gas Code (NFPA54) is intended to be followed in New York City. The reference to the latest revision of the Fuel Gas Code of New York State (FGCNYS) is intended to be followed in areas outside New York City, but within New York State.



### 1.3 EXCLUSIONS; RETROACTIVITY

Unless otherwise stated, the provisions of this book shall not be applied **retroactively** to existing installations and/or systems that were in compliance with the Rules and Regulations/Specifications and Requirements in effect at the time of installation. In cases where modifications are being made, those modifications shall be installed to conform to the specifications and requirements of this book.

### 1.4 ALTERNATE MATERIALS, EQUIPMENT AND PROCEDURES

If the contents of this book are not applicable to the equipment to be installed, or if an alternate installation method or alternate usage of material is being considered that is not covered in this book, National Grid shall be contacted for definition or clarification before proceeding with the installation. Sufficient technical documentation, such as a manufacturer's written instruction, must be submitted to substantiate any claims made regarding the safety of such alternatives.

### 1.5 RESPONSIBILITY

Pursuant to Gas Tariff's, notwithstanding any inspection by National Grid of a customer's equipment or equipment installation or any failure by National Grid to reject an equipment installation, National Grid does not provide any warranty, expressed or implied, as to the adequacy, safety or other characteristics of any structures, equipment, wires, pipes appliances or devices owned, installed or maintained by the customer or leased by the customer from third parties.

## 2.0 DEFINITION OF TERMS

The following definitions of terms used in this book have been assembled from various sources, and have been edited to be meaningful for use in this context and in the gas utility business.

**Accessory:** A device or material used to conduct gas or used in conjunction with an "appliance". In this book, some examples of accessories are valves, thermostats, appliance connectors, pressure regulators, draft hoods and interior house piping.

**AGA:** American Gas Association; an organization made up of most American gas utilities, producers and transporters, which sets standards and disseminates information throughout the gas industry in the interest of bettering industry practices and advancing safety.

**Appliance:** A self-contained device, such as a range or boiler, that converts energy into heat or other useful purpose. In this book, appliance usually relates to furnaces, boilers or water heaters.

**Applicant:** A potential customer.

**Booster:** A centrifugal blower selected to increase gas pressure when the pressure in the gas main at the customer's location is insufficient for a customer's requirements. Boosters are

usually required only in industrial or commercial applications. A booster is a machine that is designed to operate on a flat pressure vs. flow curve, which enables it to provide variable flow at an essentially constant pressure. Boosters for natural gas service normally are selected to increase pressure to no more than 28" of water column (W.C.), and are normally furnished hermetically sealed.

**BTU, Btu:** Abbreviation for British Thermal Unit. A Btu is a unit of energy defined as the amount of heat required to raise one pound of water one degree on the Fahrenheit scale, normally from 60 degrees F to 61 degrees F.

**BTUH, Btuh:** Abbreviation for British Thermal Units per hour. Also expressed as **Btu/Hr.** A standard measure of energy input and output. Typically used in the gas utility industry as a measure of the total, or capacity, of a gas appliance, such as a boiler or a furnace.

**Building:** A structure that stands alone or is separated from adjoining structures by fire walls with all openings therein protected by approved **fire** doors. In certain applications, a **party** wall may be required instead of a fire wall.

**CFH, cfh:** Abbreviation for cubic feet per hour. A standard measure of gas flow. Generally understood to mean, and often used interchangeably with, **SCFH** or **Scfh**, or standard cubic feet per hour, meaning gas measured at "standard conditions", or 60 degrees Fahrenheit and atmospheric pressure (14.7 psia or 30" mercury absolute). Typically used in the gas utility industry to express gas flow to a customer's premises and through the customer's piping. For gas flowing at the pressures generally used in a customer's premises (about 6" W.C.), flows **expressed in cfh can be assumed**, for use in calculations such as determining pressure drop in piping and valves, **to mean scfh**, with a negligible margin of error. (This assumption is not valid for metering and billing calculations where the pressures are corrected back to 7" W. C., or 0.25 pounds per square inch [PSIG].)

**CIPUD:** Commercial/Industrial Project underground distribution – a National Grid term used to describe a new commercial and industrial development project where all the utilities are furnished underground in a common trench. See RUD for residential projects and additional information.

**Connection Point of Service:** That point in the gas service line where responsibility ends and the customer's responsibility begins; or that point where gas service **piping** ends and customer-owned piping begins. Also known as Connection Point, Connection Point of Gas Service, National Grid/Customer Connection Point of Gas Service, Point of Delivery, Point of Service and Customer Interface. The Connection Point of Service may be located physically at different points in the piping, depending on the meter header configuration used, as defined on Construction Standards.

**Construction Standard:** A technical instruction, usually a drawing, but often including diagrams and tables, prepared and agreed to within **National Grid** as a standard method of performing a task, and used for the installation of gas facilities. See Project Manager for a copy of the latest job specific Construction Standard.

**Contractor:** A **licensed/qualified** installer of gas utilization equipment and associated piping, ductwork and controls.

**Conversion, Gas Conversion:** An installation where an appliance originally designed for use with a fuel other than natural gas has been modified to use natural gas, without extensive modifications to the original appliance. A typical gas conversion modifies only the burner of the appliance.

**CSA - CSA International** - an organization that tests equipment and accessories to insure it is suitable for use in a specific manner or certified to be listed to a specific Standard.

**Customer:** A user of gas. A customer may be a person, firm, partnership, corporation, association, developer, builder, or governmental agency to whom gas is supplied and billed by National Grid. All National Grid customers are provided, emergency assistance at no charge, covering generic concerns relating to the meter, the gas service, gas odor reports, low or high gas pressure, gas service outages, and other unusual conditions relating to the gas supply.

**Residential Customer:** A customer supplied by National Grid with gas service at premises used as his/her residence, or a landlord's residence, through a separate meter.

**Commercial Customer:** A customer supplied by National Grid with gas service at his/her business premises through a separate meter.

**Multiple Dwelling Customer:** A customer supplied by National Grid with gas service at premises used as his/her residence, but in a multiple dwelling building, normally through a separate meter, but sometimes through a common meter as conditions warrant.

**Interruptible Customer:** A customer supplied by National Grid with gas service at his/her business premises through a separate meter, that may be interrupted at critical times as agreed to by the contract with National Grid. These customers **shall** have the capability of burning a second fuel, when the gas service is interrupted.

**Temperature Controlled Customer:** A customer supplied by National Grid with gas service at his/her business premises through a separate meter, that will be interrupted at an annually pre defined temperature as agreed to by the contract with National Grid. These customers should have the capability of burning a second fuel, when the gas service is interrupted.

**Transportation Customer:** Residential or commercial customers who purchase natural gas directly from a gas supplier, rather than from a utility. The customer contracts with a gas broker, who arranges monthly with a supplier, a gas pipeline company and National Grid to have quantities of gas transported directly to him/her (the customer). Transportation customers are billed both by the gas broker and by National Grid. The broker's bill reflects the commodity cost, the transportation cost (interstate pipeline) and the broker's commission.

**Customer Owned Piping:** Is defined as all piping above ground and below ground installed after the meter. It is the customer's responsibility to install, test, maintain and keep records of this piping.

**Dekatherm:** A therm multiplied by 10 (10 therms). A commonly used quantity of gas used for billing purposes. Also see *therm*.

**Elevated Pressure** Gas supplied to a customer's equipment at pressures greater than 7" W.C. (0.25 PSIG).

**Easement:** Right to pass over, occupy or use another's land for the placement and access of company service facilities.

**Fire Wall:** Similar to a Party Wall in construction, is generally an *internal* wall. However, openings, between adjoining areas, such as fire doors, or extensions of facilities, are permitted in firewalls. Both party walls and firewalls may have different construction requirements and/or different fire ratings, depending on the type of building. Consult state and local codes for further clarifications.

**Gas Business Lead:** The National Grid Gas Marketing and Sales employee who is the prime contact for the customer when a new installation or a conversion is undertaken. The Gas Business Lead provides economic, technical and policy information regarding the use of natural gas for all applications; e.g. heating, water heating, process uses, etc. **New Construction Representatives** handle gas heating for all new home and development construction and **Commercial and Industrial Representatives** handle the commercial **Industrial and Multi family** market. **Key Account Executives handle** large buildings and chain accounts (e.g. schools, hospitals, department stores).

**Gas Distribution System, Low Pressure:** A gas distribution piping system in which the pressure is substantially the same as the standard pressure delivered to the customer and where service regulators are not installed.

**Gas Distribution System, High Pressure:** A gas distribution piping system in which the pressure is nominally higher than the standard pressure delivered to the customer and therefore requires a service regulator. gas distribution system may furnish gas to the customer's service location at several different pressures, depending on the geographical area served. For the purposes of this book, all pressures are referred to as **high pressure**. For information, pressures serving the areas may be: Intermediate - nominally 50" w.c. (2 psig); Medium nominally 10 or 30 psig; or high - 60 psig or higher.

**Gas Service, Gas Service Line:** A gas service, or gas service line, is the pipe that provides gas from a gas main in a public area to a customer's building. The gas service is installed and owned by National Grid in most cases. **Gas service line means the piping, including associated metering and pressure reducing device(s), that transports gas below grade from a main to the outside of the building foundation wall where the meter is located outside the building. If the meter is located inside the building, the service line terminates at the first accessible fitting inside a wall of the customer's building.** In some specific cases, because of unique physical conditions, contractor installed, buried, customer-owned piping must be **treated as a gas service**, and must therefore be installed in strict accordance with Section 8 of this book.

**Gas Technical Lead:** The National Grid person from the Gas Sales Project Management or C.M.S. (Customer Meter Services) who is the technical contact for the customer when a new installation or a conversion is undertaken.

**IAS:** International Approval Service – An organization that tests equipment to insure it is suitable for use in a specific manner.

**Integrated Schedule:** Also National Grid/Builder Integrated Schedule. A preliminary schedule used in RUD projects as well as selected commercial gas-only jobs, that specifies design and construction activities, milestones and commitments agreed to between National Grid and the builder(s).

**Installer:** See Contractor.

**Labeling:** “appliances shall be listed and labeled” (no longer MEA required, OTCR (Office of Technical Certification and Research) created to recognize code-prescribed and alternative materials)

**LIPA:** Long Island Power Authority.

**Listed:** Equipment or material included in a list published by an organization acceptable to National Grid, such as the IAS or Underwriters Laboratories (UL) **MEA**, and concerned with product evaluation that maintains periodic inspection and evaluation of the production of listed equipment or materials. A typical listing states that the equipment or material meets appropriate standards or has been tested and found suitable for use in a specified manner.

**Low Pressure Service:** Gas supplied to a customer from a low pressure gas main.

**Meter:** The instrument used to measure and indicate and/or record the volume of gas that has been delivered to a customer.

**Meter Bar:** A specialized item of hardware that functions as a connecting device between the gas service line and the gas meter.

**Meter Set:** The term used to describe the meter and its related piping and equipment. Often synonymous with *meter header, meter installation*.

**Meter Header:** The piping and equipment installed at a customer location relating to and in support of the meter.

**Multiple-Family Building:** A structure, including row houses, enclosed within exterior walls or fire walls, built, erected and framed of component structural parts, and designed to contain five or more individual dwelling units for permanent residential occupancy.

**Multiple Services to a Building - only one service will normally be permitted to a building; a separate building shall consist of either a detached, separate structure, or an attached structure separated from the first structure by a party wall, as defined in the New York State Uniform Fire Prevention and Building Code.**

**Nominal:** The standard pressure at which National Grid furnishes gas to customers. Nominal pressure depends on the pressure of gas main at a given installation. When served from a high pressure main, nominal pressure is **6" W.C.** When served from a low pressure main, nominal pressure can vary from 4.0" W. C. to 9.5" W. C. Nominal pressure is taken to be the pressure

measured at the **connection point of service**. See Section 6.0 of this book for more information.

**Party Wall:** A party wall shall contain no openings therein. A party wall shall be continuous from the lowest floor level of the building through the roof membrane, and shall terminate in a two foot parapet (except where properly sealed at the roof level). Party walls shall bear the proper fire rating as per the NY State Code, and shall be smoke tight at the exterior walls. They shall also be capable of supporting either side of the roof assembly in the event of a collapse.

**Project Manager:** National Grid's primary contractor liaison for large volume Non-residential, Commercial and Industrial installations.

**Regulator:** A device used to reduce the pressure of gas from a higher pressure at its inlet to a lower pressure at its outlet, maintaining that pressure essentially constant, while also controlling the flow of gas; usually mounted directly in gas piping.

**Regulator, Line:** A regulator provided by the customer (see definition above) used on elevated pressure installations (pressures greater than the nominal 6" W.C.), that is mounted in the house line between the service regulator and the appliance regulator, and reduces gas pressure from that elevated pressure to the typical nominal houseline pressure of 6" W.C. This regulator must provide a bubble tight (dead end lock-up) with full relief capacity.

**Regulator, Service:** A regulator that reduces and controls gas main pressure to the pressure of the customer's house line. Usually set by National Grid to supply gas at 6" W. C., gas at a higher pressure can be furnished if the end-using equipment is specified by the manufacturer to require a higher pressure. This regulator is furnished, installed and maintained by National Grid.

**Regulator, Appliance:** A regulator (see definition above) mounted at the appliance, (normally furnished with the appliance) that reduces the house line pressure to the pressure utilized by the appliance.

**RUD:** Residential Underground Distribution. A National Grid term used to describe a new building project for residential developments of five or more dwelling units where all the utilities are furnished underground in a common trench. Extensive coordination is required within National Grid regarding the electric and gas installations to the development, as well as coordination outside with other utilities, such as telephone and cable television.

**Security Valve:** A control valve, installed on a meter header, usually for a large load, that is set to close automatically upon sensing one or more gas parameters, usually high and low pressure. A meter header using a security valve is normally designed by National Grid.

**Sediment Trap:** "a tee fitting with a capped nipple in the bottom opening of the run of the tee or other device approved as an effective sediment trap – to collect solid foreign particles to prevent such material from entering close-fitting parts or small passageways (e.g., valves and orifices)

**Service Riser: (Sweep el)** That portion of gas service line where the piping comes out of the ground.

**Tariff:** A compilation of written definitions, statements, rates, rules and regulations that together describe basis for doing business, and that have been approved by the New York State Public Service Commission.

**Therm:** A unit of heating value equivalent to 100,000 BTUs. Gas is normally billed by the therm, or by the **decatherm**, which is a therm multiplied by 10 (or 10 therms). A cubic foot of gas is generally equal to 1,000 - 1,060 BTUs as supplied by National Grid .

**UL:** - Underwriters Laboratory - an organization that tests equipment and accessories to insure it is suitable for use in a specific manner or certified to be listed to a specific Standard.

**Warning Tag; Warning Tag Procedure:** A New York State mandated set of detailed safety warning criteria in which gas utilities are required to provide notice to customers upon discovery of potentially unsafe gas piping and appliances. National Grid executes this mandate via a Warning Tag procedure, which serves notice of a problem to customers by leaving a warning tag at the premises. A warning tag is issued when a condition is identified in which a gas appliance or gas piping are deemed to present a hazard to life or property if allowed to operate in the condition found. Conditions requiring the issuance of warning tags fall into three classes:

- Class A: Those conditions that present an immediate hazard and require the gas to be shut off and locked at the meter or effectively isolated in some other manner. A Class A warning tag is generally found to be associated with leaking gas piping, or carbon monoxide.
- Class B: Those conditions that present an immediate hazard and require the gas to be shut off, but not locked at the meter, unless the hazard can be isolated from the rest of the gas system. Class B warning tags are generally found to be applicable to unsafely installed appliances or related equipment.
- Class C: Those conditions that do not present an immediate hazard, but if not corrected may become hazardous. The gas will be left on. A Class C warning tag can be issued for a variety of reasons, most often related to appliances. Examples would be an improperly installed flue pipe or an electrical hazard.

**W.C., w.c.:** Water column; the standard scale of measurement, expressed in **inches of water column**, used in the natural gas industry to measure gas pressure. The units of inches of water column (W.C.) are commonly used for pressures below **1 psig**. 1 psig = 27.8" W.C. Gas customers are typically furnished natural gas at a pressure of 6" W. C. which is about 1/4 **psig**.

### 3.0 **GENERAL**

#### 3.1 **AREA/GEOGRAPHICAL CONSIDERATIONS**

The working area of National Grid Gas Business Unit **on Long Island** geographically encompasses Nassau and Suffolk Counties as well as those portions of New York City **supplied by National Grid**. National Grid also cover the Albany and Syracuse territory. Therefore, in order to ensure that all installations utilizing National Grid supplied gas are consistent in their usage, but are still in compliance with regulations in these different geographical areas, the book has been designed to apply generically to all of these areas.

Where it is appropriate, it addresses needs by specific geographical location. It is the customer/plumbing contractor's responsibility to become familiar with the specific requirements of the area of the installation. The reader is strongly encouraged to check with the village, town, city and county governments applicable to his/her installation, to determine if regulation changes have been made, or to determine if any new regulations have been enacted, since the creation of this document.

#### **NOTE**

***The knowledge of the existence or absence of regulations within a given jurisdiction is the responsibility of the contractor.***

### 3.2 **COMMUNICATION / COOPERATION**

It is our goal at National Grid to ensure that all of our customers experience safe, trouble-free and dependable gas service. Achievement of this goal begins early in the process of any gas installation. We believe that this can best be accomplished through close cooperation and communication with our customers and their contractors, to assure a quality job, during all phases of the planning and installation of a gas service. ***Therefore, it is vital that both customer and contractor provide us with preliminary information as early as is feasible in the development of plans for the installation of a new gas service or an increase in gas load.*** With this information we can ensure that the scheduling of our construction work, meter installation and other service work is appropriate. It will also provide us with an early opportunity to advise customers and contractors if any unique job characteristics exist concerning gas equipment and metering facilities. This kind of communication and cooperation, along with careful adherence to the instructions and specifications in this book, is crucial in preventing delays at any point in a job, and avoids problems that may be difficult to correct later on. We believe that this is the most effective way to ensure complete customer satisfaction with our gas service.

### 3.3 **MEANING OF "SHALL" IN THIS BOOK**

When used in this book, the word ***shall*** is to be understood to mean that the contractor/customer must comply to the fullest extent with the specification, action or physical requirement described. Failure to comply will result in refusal to provide a meter or connect to our gas system. Where a National Grid First Inspection is concerned, failure to implement these specifications, actions or physical requirements will result in a failed inspection. Other resultant actions could be Class "A" or Class "B", warning tag violations, which require further action by the contractor/customer before National Grid releases the job for final use by the customer, or refusal by National Grid to provide service. The meaning of the term "must" is considered to be the equivalent of the term "shall" in this book.

### 3.4 **STATE AND LOCAL CODES**

The specifications and requirements in this book are intended to supplement or amplify any State, City, Town or Village code or ordinance. If a conflict exists between a National Grid requirement and a local code requirement, the more stringent shall apply. ***It is the Contractor's responsibility to be aware of the code requirements for the area of his/her installation. National Grid does not assume the obligation of enforcing local code requirements.***



### 3.5 RESPONSIBILITY FOR CODE APPLICABILITY

The use of the information and standards contained in this book by any contractor in no way releases them from the responsibility of becoming aware of and implementing local, state or national codes that may be applicable in the location where the installation is located, except that the standards and requirements contained herein shall always apply *when they are more stringent*.

### 3.6 INSPECTIONS, CERTIFICATES, PERMITS

If the local jurisdiction where an installation is being planned requires an inspection, a certificate or a permit, it is *the owner/contractor's responsibility* to make the appropriate arrangements.

### 3.7 ACCESS TO CUSTOMERS' PREMISES

National Grid shall have the right of access, at all reasonable times, to all its property installed in or on the customer's premises. This shall include items such as buried service lines and valves, exposed service lines and valves, gas meters, gas regulators, or gas regulator vents. National Grid shall reserve the right to erect, remove, operate, or maintain our facilities, and to read and test our gas meters on the customer's premises.

### 3.8 IDENTIFICATION OF EMPLOYEES

Every National Grid employee who is authorized to enter the customer's premises for the purpose of reading or testing meters, investigating odor complaints, or for other purposes, is supplied with an identification card bearing his/her photograph. Employees must, upon request, show their identification cards. If anyone claims to represent the Company and fails to display an identification card upon request, the customer is advised to deny admittance to that individual and to notify both National Grid and the police.

### 3.9 UNAUTHORIZED CONNECTIONS

National Grid shall have the sole right to make all gas service connections to its gas distribution system.

### 3.10 SEALS AND TAMPERING DEVICES

No person, except a duly authorized National Grid employee/contractor shall be permitted to break or replace a seal or lock, to alter or change a gas meter or its connections or location, open or alter a meter by-pass valve, or to alter a gas pressure regulator setting.

### 3.11 DISCONNECTION OF SERVICE

National Grid possesses the sole right to disconnect, remove or reset gas services and/or meters, and to admit gas to any new system of piping or to any old system of piping from which the use of gas has been temporarily discontinued. When installers find it necessary to disconnect a meter or to temporarily shut off the gas, they are requested to re-connect the meter and to re-light the appliance. It is not necessary to call National Grid.

### 3.12 REACTIVATING GAS SERVICE FOLLOWING A WARNING TAG VIOLATION

- 3.12.1 When National Grid issues a Warning Tag to the customer that involves shutting off the gas supply to an individual appliance and/or a particular section of gas piping due to a hazardous condition, service does not need to be restored by National Grid. Once repaired, gas service may be restored to the effected appliance and/or piping by a licensed qualified contractor.
- 3.12.2 When National Grid issues a Warning Tag that involves the gas supply being shut-off and locked at the meter, the contractor or customer shall notify National Grid that the hazardous condition has been corrected and request that National Grid turn on the gas supply.

### 3.13 NATIONAL GRID EQUIPMENT ON PRIVATE PROPERTY

All National Grid equipment located on the customer's premises, such as the gas service line, meter, regulators, meter piping, etc., remain National Grid property, and may be removed by National Grid in the event such equipment is no longer needed.

### 3.14 DEMOLITION

Prior to any demolition of any existing building where gas and/or electric service is installed, the gas and electric must be shut off and the gas service lateral cut by National Grid at the property line. No building demolition shall be started until gas meters and regulators have been removed and the gas service has been retired (physically disconnected) by National Grid. **Call (516) 545-4943 or (631) 348-6150 for Long Island and (718) 643-4050 or (718) 403-2147 in Brooklyn, Queens and Staten Island.**

### 3.15 INTERCONNECTIONS

- 3.15.1 When a supplementary fuel supply for stand-by use is connected downstream of a gas meter, an adequate, full-port, three-way valve shall be installed between the meter and the stand-by fuel piping connection. The stand-by fuel piping and the natural gas piping downstream of the three-way valve shall be equipped with shut-off valves. Three-way valves of the type that completely close one port before starting to open the other port shall be used. The three-way valve shall be suitable for use in natural gas service and the supplementary fuel supply used at the site where it is installed.

### 3.16 BACK-PRESSURE, AND SUCTION PROTECTION

- 3.16.1 When the nature of a customer's utilization equipment may induce back-pressure or suction in the piping system carrying gas (such as a gas booster), suitable protection devices shall be installed and maintained by the customer. The contractor is referred to Sections 5.10 of NFPA 54 and Section 414 of the FGCNY. National Grid's project manager should be contacted when this application is to be used.

### 3.17 PROTECTION WHEN COMPRESSED AIR OR OXYGEN CAN ENTER GAS PIPING

(Including torches, jewelry torches)

3.17.1 Protection is required whenever an installation uses compressed air or oxygen that might accidentally, or for other reasons, cause air or oxygen to enter the gas piping. The contractor is referred to Sections 7.12 of NFPA 54 and Section 414 of the FGCNY. Protection devices, such as flame arrestors and check valves shall be installed and maintained by the customer, National Grid's should be contacted when this application is to be used.

### 3.18 ADEQUACY AND SAEFTY

3.18.1 *National Grid shall not be required to supply gas service until the customer's installation has been approved by the local authorities having jurisdiction.*

National Grid reserves the right to withhold its service or discontinue its service, whenever an installation or part thereof is deemed by National Grid to be unsafe, inadequate or unsuitable for receiving service or interferes with or impairs the continuity or quality of our service to our customers or to others. An example of a situation where National Grid will refuse service is that in which a piping pressure test shows unacceptable results.

### 3.19 CODE COMPLIANCE

3.19.1 Gas appliances and gas piping installations on the customer's premises shall be installed in compliance with the minimum safety requirements of these standards and the National Fuel Gas Code. These provisions shall be applicable to new installations and to modifications of existing appliances or systems. Any appliance or system found to be in non-compliance with National Grid standards or other applicable codes shall be subject to the provisions of Warning Tag Procedure (see Definitions, Section 2.0).

3.19.2 The NYC Building codes, Fuel Gas Codes of NY State and applicable State Codes shall be followed in NYC.

### 3.20 REVISIONS OF THIS BOOK

3.20.1 The information in this book will be periodically revised, updated or amended **on-line only** as required by industry developments to protect the mutual interest of the customer and National Grid. *The printed versions will no longer be available and shall not be referenced any longer. The on-line version will be the only valid issue of the BlueBook.*

## 4.0 NEW GAS SERVICE INSTALLATION PROCESS

### 4.1 GENERAL

4.1.1 To initiate a new gas installation or to advise National Grid of an additional gas load, call ***1-877-MyNGrid (1-877-696-4743)***.

4.1.2 A logical progression of events and requirements for having a new gas service installation is provided in Section 4.2. It is important for contractors and customers to become familiar with this material in order to determine how a new

gas service installation or a conversion progresses through the National Grid system.

4.1.3 For any new installation, the customer or his/her contractor shall provide National Grid with a **load letter** identifying all gas equipment and required operating gas pressures.

- Gas pressure required at service termination point,
- New, existing and future projected loads.

Information provided to National Grid by the customer or his/her contractor regarding a proposed gas installation or an increase in load shall generally be required in writing.

4.1.4 The applicant or customer shall furnish at the premises, at his/her expense, appropriate piping and equipment for gas utilization purposes. Piping shall comply with requirements in Section 5.0, 7.0 and 8.0 of this book. Gas utilization equipment shall comply with Section 9.0 of this book.

4.1.5 Customers already using gas service from National Grid shall advise the company of any addition or substantial change in his/her equipment, such as increasing a boiler size to accommodate a new building wing or adding a swimming pool heater, or generator, *prior to* making such additions or changes. Any requests for equipment requiring pressure greater than 3.5" w.c. must be approved by National Grid before the equipment is purchased. In some instances elevated pressure is not available. (All requests for an increase in service capacity, shall require the customer/contractor to complete the Residential Gas Service Agreement – See appendix C)

4.1.6 For all new installations, the customer shall be expected to provide, at his/her expense, any and all permits or certificates (except street excavation permits) usually issued by public agencies, that are associated with piping and appurtenances downstream of the meter, as part of the requirements in furnishing gas service downstream of the meter. Any easements required for the job shall also be provided by the customer at his/her expense. Plumbing permits shall be obtained by the plumbing contractor. **Customer is responsible to mark out all customers owned buried facilities on private property in vicinity of the proposed gas service.**

4.1.7 National Grid shall not be obligated to begin construction on the gas service or to supply gas to the customer until:

- The applicant furnishes all necessary permits to National Grid, and easements and/or rights of way are granted;
- The customer's application has been approved by proper officers or duly authorized representatives of the company;
- Necessary payments are made by the applicant;

- A signed contract between the customer/owner and the contractor is provided to National Grid.
- 4.1.8 Prior to the beginning of every job, when National Grid deems appropriate, meetings will be held as required. At these meetings, the design and construction process will be discussed. The meetings will be arranged so that the various contractors and any other relevant representatives will be able to attend.
- 4.1.9 The Appendices contains requirements for construction and other information relating to the construction process. This material is intended to assist in providing a better understanding of needs, thereby allowing for better planning on a job. Although many of the materials and issues covered in this Appendix are relevant to National Grid oriented installations, the information presented is valuable for any installation in terms of understanding construction policies and philosophy.
- 4.1.10 After all of National Grid's preconstruction activities and requirements have been completed and approved, National Grid's installation crew will meet the established, mutually agreed upon construction due date, providing the work area meets all of the requirements contained in this Appendix. **National Grid will install gas services within 21 days of generation of an authorized work order number or will meet construction due dates established by sales.**

It is important to the installation of the gas main and service that a complete and accurate inspection of field conditions is made before commencing construction and installation of National Grid's gas facilities. All new orders for main and service installations will be field-checked by National Grid **before and/or** after receipt of the authorized Work Order. Existing orders will be field-checked within a timely manner as determined by field conditions such as the rate of construction, scheduled installation of other facilities or when the customer, plumber or builder shows that the area of construction is clear of violations and that all is in readiness at the site for National Grid's construction to begin. Note that it is not necessary for the customer to be present for this inspection. For sites where the gas meter will be located indoors, National Grid will not release a job until the inside meter location has been inspected for required clearances and accessibility. An entry key, or other suitable means of access, shall be arranged so that National Grid can gain access to the building.

National Grid shall apply for road opening permits before excavating in the roadway. National Grid will not install or excavate without receiving the proper permits from the municipality or town where the installation is located. The time required for issuance of permits will vary according to the municipality, i.e., town, **city**, county, state, **village** having jurisdiction. National Grid will not be responsible for delays incurred in the permit process due to internal municipality delays.

Before the actual start of construction for large installations of mains and services, or as deemed necessary by National Grid, a site meeting may be required.

The purpose of this meeting is to effectively communicate the scope of work, site status, job progress and other work items to all concerned parties. During this meeting, the following shall be discussed:

- Finalization of the integrated construction schedule
- Review of approved drawings
- Identification of key contact people
- Identification of below-grade facilities in vicinity of work area
- Site readiness

National Grid requires that this pre-construction meeting take place at least two weeks before the schedule date of construction activities. National Grid's Technical lead will coordinate the scheduling of the meeting with the contractor.

**CAUTION!**  
**BEFORE YOU DIG!**

*All excavators shall be familiar with 16 NYCRR Part 753, "Protection of Underground Facilities". Contractors are advised to exercise extreme caution when breaking ground. Before you dig, drill or excavate, be sure that your work area is clear of buried gas pipes or electric cables. An accidental break of these facilities can be dangerous! Telephone the One Call Center at least (3) three working days before you start work. The location of any existing LIPA, Con-Ed buried cable or National Grid buried pipe will be marked along with telephone, water and cable. The utility will not mark customer-owned buried facilities on private property. Contractors shall not begin any excavation work until all call-backs are made from utility operators contacted as a result of the One Call Center telephone call. If facilities are not marked **DO NOT ASSUME** that there are not facilities present in the area. Note that the customer and/or contractor are responsible for marking facilities on private property. If sub-contractors are hired, please remind them that they are obligated to call the One Call Center before they do any excavating work*

In areas where property lines have not been established, or where curbs are not installed, ***the customer or contractor shall provide National Grid with accurate information as to buried items, such as underground mains and services, drainage, sewers, oil tanks, cesspools, etc.*** Before National Grid begins work on a main or service, curbs shall be installed. Property lines and grades are especially important in developments where roads are cut to a rough-grade that may be as much as 3 feet below or above sub-grade. Determination of sub-grade facilities and their locations are very important as our mains and service installation depends on accurate fixed points to decide proper depth of a trench. National Grid will only begin work where it has been validated that the existing grade is within 6" of final grade.

National Grid will expedite the gas piping main and service installation by establishing communications with the customer, builder, plumber or project superintendent by informing them of existing violations that would prevent the installation of gas facilities.

## **NEW GAS MAIN INSTALLATIONS REQUIREMENTS**

Before the installation of any **new gas main**, the customer shall have the construction area free of any violations within their control. All violations shall be cleared before the National Grid work order for the gas main installation can be released for construction. For National Grid construction activities to take place, the following requirements shall be adhered to:

### **PROPERTY LINE**

For new building developments, curbs shall be installed before National Grid will install a gas main. **Exceptions to having curbs installed may give** if it is not intended to install curbs, the customer/contractor shall inform National Grid accordingly, and provide reasonable assurance that the grade level is within 6" of final grade. Gas mains are normally installed on public property (roadways), however, their location may deviate due to varying terrain, heavy growth, large trees, catch basins or, due to a request of municipal authorities. National Grid will not install a gas main when curbs have not been installed and property lines have not identified.

### **GRADING PREPARATION**

To ensure proper earth cover for the proposed gas main, National Grid will talk with the customer or builder to determine the present and future grade of the road. This is essential where the original grade stakes have been torn up or buried. National Grid requires a **36-inch cover** over its gas mains, and a minimum of a **6-inch separation** between other facilities and materials.

**For Nassau & Suffolk County** the **National Grid** Construction Standard Number CNST-6125 shall be consulted.

### **DRAINAGE**

National Grid will not release the Work Order for a gas main installation until all drainage facilities have been installed and, if existing, their locations identified by the customer, installer or the authority having jurisdiction. When drainage locations are known, National Grid can offset or place the new gas main above or below the existing drainage facility to lessen the risk of damage to the pipeline. **In certain situations the work package can be released based upon the discretion of the National Grid Field Engineer.**

### **WATER MAINS AND SERVICE STUBS**

Since water mains are installed at a greater depth than gas mains, National Grid will not install a gas main until the water main and service stub are installed and properly marked out. Water mains and services shall be installed before the gas main installation to prevent interference between the two piping systems and to eliminate the possibility of the gas main being damaged when a water main is installed.

### **OTHER OBSTRUCTIONS**

On the day that National Grid is scheduled to install the gas main, the contractor shall remove all obstructions such as dirt piles, building materials, equipment or vehicles that will prevent National Grid from installing a gas main. The area, when the new gas main is to be installed, shall be cleared before trenching of the new gas main begins.

### **NEW GAS SERVICE INSTALLATION REQUIREMENTS**

Before installation of a **new gas service**, the customer/contractor shall have the construction area free of any violations. All violations shall be cleared before any gas service Work Order is released for construction. For National Grid construction activities to take place, the following requirements shall be adhered to:

#### **GRADE, COVER**

It is important that the grade be as close to the proposed finished minimum grade of 6" below final grade before National Grid releases the service to be worked. This is to ensure that proper earth cover exists for the proposed service. The depth of **cover required** for a gas service is **24 inches** for public property and a minimum of 18 inches for services on private property. **For RUD Applications, the Electric Utility's** Construction Standard's shall be consulted for further details.

#### **WATER SERVICE**

Often, water services are installed on the opposite side of the building away from the gas service. If the water service is installed in close proximity to the proposed gas service, National Grid requires that the **water service** be installed **before the gas installation**. This is required since the water service is installed at a depth below National Grid's gas service. Therefore, the **water service must be installed** to prevent the gas service pipe from being damaged by the water service construction. A water service shall be kept a minimum of 3 feet away from a gas service measured in any direction.

#### **CESSPOOLS & SEPTIC TANKS**

If cesspools or septic tanks are to be constructed in proximity to a proposed gas service, that construction and back filling shall be completed first before National Grid will install a gas service. Experience has shown that equipment used for excavating cesspools or septic tanks have often torn up National Grid's piping when the gas service is installed before the installation of a cesspool or septic tank.

#### **BUILDING MATERIALS**



Building material, such as lumber, sheetrock, pallets, scaffolding, dumpsters, bricks, etc. located in the path of the gas service, will cause delays in the installation of the gas service. The customer and/or builder shall maintain a clear area or path so that trenching or missiling for the new gas service can be accomplished.

### **DIRT PILES**

Dirt piles of a size requiring additional work in excess of normal trenching or missiling operations shall be removed by the customer or builder before the release of the job.

### **FOUNDATION ONLY**

Gas services shall not be installed where only a building foundation exists.

### **STRUCTURES NOT BUILT YET**

National Grid will not run gas services or stub to any proposed buildings or other structures, or run services beyond the property line. If deemed necessary by National Grid, we will install a service stub/main to the property line for any proposed building.

### **TRENCHES**

Contractors electing to provide their own trenching for National Grid's facilities shall adhere to the following requirements. Contractors shall trench only on private property. **IN NYC, trenching is allowed in the public right-away if mutually agreed upon by all parties.**

### **COVER**

Trenches for facilities shall meet the following minimum cover requirements:

- 36" for Gas Mains
- 24" for Gas Services on Public Property
- 18" for Gas Services on Private Property

LIPA's Construction Standard shall be consulted for further details, when working on Long Island.

### **TRENCH BOTTOMS**

**National Grid and NYC Specifications and Standards shall be consulted for work performed in NYC.** Trench bottoms shall be smooth and free of rocks or debris that could damage plastic mains or services, or could damage protective wrapping on steel mains or services **when trenching in Nassau and Suffolk counties.**

## **SPOILS**

All spoils shall be placed a minimum of 24" from the edge of the trench.

## **RUD/SEPARATION, GAS VS. ELECTRIC/TELEPHONE/CABLE**

If trenching is to be accomplished for placement of facilities in a common trench (RUD), trench must be wide enough to allow for a 6" minimum separation between buried gas facilities and buried electric, telephone and cable facilities. LIPA's Construction Standard shall be consulted for further details. National Grid will not place facilities into trenches unless the requirements for proper separation are met, as defined below.

## **3-PHASE PRIMARY LATERAL WITH GAS**

If trenching is to be accomplished for installation of gas facilities along with a 3-phase primary lateral service, a minimum of 12" separation must be provided between electric lines, and a minimum of 6" separation must be provided between gas and electric lines. LIPA's Construction Standard shall be consulted for further details.

## **SEPARATION OF FACILITIES**

If trenching is to be accomplished for installation of gas and electric services on private property, the minimum cover on gas and secondary electric is 24" with a minimum of 6" separation between the two services. If the service is primary, it may be placed in a conduit at 24" cover; if it is direct-buried, it must have a minimum of 30" cover. In Long Island, LIPA's Construction Standard shall be consulted for further details.

## **BACKFILL AND PERMANENT RESTORATION**

When contractors provide trenching on private property, backfilling of the trench along with the temporary and permanent restoration of the work area shall be the responsibility of the customer/contractor and shall be completed in accordance with CNST01003. When National Grid trenches on private property, National Grid will provide temporary restoration of terrain of pavement.

### **4.2 REQUIREMENTS FOR HAVING A NEW RESIDENTIAL AND SMALL COMMERCIAL GAS SERVICE INSTALLED**

- 4.2.1 Upon contacting the National Grid Representative, advise if the installation is a residential, commercial or industrial building, and, if you are a builder, if it is a RUD project. The National Grid Representative will determine if gas is available at your location. If gas is available, the National Grid Representative will assign the job to the appropriate sales representative or Gas Business Lead, who will then identify the proper application forms and send them to you along with a packet of relevant information. Residential applicants may initiate the application process by telephone. Commercial and industrial customers are required to initiate their applications in writing. Additional information for RUD and CIPUD projects is provided in Section 4.3.

Please note that if gas is not immediately available in your area, the information in the following sections is not necessarily applicable. The National Grid Representative will explain the process to be used.

- 4.2.2 The National Grid Representative assigned to you will help determine the Rate and Service Classification most favorable to your current requirements. National Grid does not warrant that the choice will be most favorable to all possible future requirements of any applicant or customer.
- 4.2.3 The customer is advised that a search will be made regarding the gas history of the premises with National Grid, as well as the history of the individual applicant. If any credit arrears are reported or meter tampering or theft of service is found, it is possible that service could be denied.
- 4.2.4 Following receipt of the application, the National Grid Representative may schedule a field visit to the location if required and if the job requires a service only, will determine the preferred meter location with the customer.
- 4.2.5 For installations requiring a service only, the National Grid Representative will cosign an application with the customer. In addition, National Grid must see a **signed contract** between the customer/owner and the contractor before National Grid will begin work. No exceptions will be made to this requirement.
- 4.2.6 National Grid will install the required facilities in accordance with a mutually agreed upon Customer/National Grid Agreement Date. National Grid will track the installation with the contractor and customer for a timely completion and meter set, assuming all permits have been properly obtained.
- 4.2.7 It is the contractor's responsibility to obtain any necessary certificates or permits from governing authorities to ensure that a meter is set on the agreed upon date. In addition, it is the contractor's responsibility to arrange for pressure tests.

*Note:*

*It is the contractor's responsibility to arrange a pressure test with the authority having jurisdiction to ensure that a meter is set by the agreed upon date. Pressure tests on commercial and industrial installations shall be witnessed by the local agency when required in accordance with Appendix D of this manual.*

4.3 RUD AND CIPUD SERVICE (where applicable)

- 4.3.1 The following requirements apply to builders who construct homes and to land developers.
- 4.3.2 In order to initiate RUD service, the following items shall be prepared by the builder or land developer and be available prior to filing the application:
  - A completed Request for National Grid Underground Installation, available at each divisional location

- A completed National Grid Gas Request Form
- Six copies of an approved site plan of the subdivision, showing the location of each lot, sidewalk, roadway/curbline, storm drains/sewers, water main and grade changes. The site plan must be approved by all governmental authorities having jurisdiction. In addition, an AutoCad file is requested, if possible.
- A completed National Grid Request for Easement Information form
- Relevant load information for non-residential structures
- A copy of the preliminary construction schedule

*Note:*

*The builder/developer may elect to perform the trenching necessary for the installation of the buried facilities in any given sub-division. The credit per trench foot for service laterals and distribution is based on filed tariff costs provided all work is performed in accordance with National Grid specifications and schedules. This option may be discussed with the Business Lead upon initial contact.*

- 4.3.3. For RUD and CIPUD jobs involving gas and electric, builders and land developers are advised to contact **1-877-MyNGrid** to initiate gas service according to Section 4.2.1 of this book. Advise the National Grid Representative that the job is RUD or CIPUD. A Business Lead will be assigned and the contractor will be given further instructions on the RUD/CIPUD process, including the following:
- Builder or land developer performance payments
  - National Grid scope of work and other associated charges
  - National Grid Energy's Integrated Project Schedule
  - Trenching considerations
  - Joint Parity Agreement with the telecommunications utility, if applicable to the contractor
- 4.3.4 The builder of a subdivision must pay National Grid, in advance of construction, a nonrefundable charge for any main or service footage required in excess of the gas allowances. The allowances provide up to 100 feet of gas main and up to 100 feet of gas service line for each residential heating customer. This is based on National Grid's currently filed Tariff PSC No. 4, Gas, and is subject to change. Should additional lengths of main and service be required, National Grid may justify waiving these excess footage costs by performing an analysis of the customer's adjusted gas revenues.

4.3.5 Gas refundable charges may be allowed. The gas refundable charge will be equal to the total of National Grid's free gas allowance portion of the installation. This charge will be refundable in whole or in part upon commencement of gas service. In lieu of the gas refundable charge, to cover the costs of such installation, National Grid may offer the builder the option of entering into a Gas Waiver Agreement with National Grid. This arrangement provides for National Grid to waive the requirement for the advance gas refundable charges. In consideration of such waiver, the builder agrees that if buyers of fewer than 90% of the homes choose full gas service for space heating, the builder will pay National Grid a percentage of the refundable charge for each home without gas heating service.

4.3.6 Table 4.1 lists RUD/CIPUD Milestones for builders' and land developers' information.

**TABLE 4.1  
RUD/CIPUD PRE-CONSTRUCTION MILESTONES**

<b>DESCRIPTION</b>
National Grid Business Lead/Builder contact established
Builder submits Design Package including: Application, site maps and or ACAD File, request for easement form, Underground Electric installation form
National Grid completes Preliminary Distribution Facility Design Layout (Redline/Greenline Stage)
National Grid notifies Builder of Payment Schedule
National Grid /Builder agree to Project and Integrated Construction Schedule
Builder signs Gas Waiver Agreement/National Grid receives First Payment (Design Payment)
Land Developer submits 100% payment
National Grid proceeds with Final Design/Permits/Schedule
National Grid /Builder review Final Design/Integrated Schedule
National Grid receives Second Payment (Materials Payment)
National Grid procures Materials and finalizes Easement Agreement
Builder submits Refundable and/or Non-refundable gas payment if the Gas Waiver Agreement is applicable
Builder submits copies of Sales Contracts including Performance Payment schedule and final payment
National Grid sets up Construction Meeting at Job-Site – See Appendix D
National Grid coordinates Construction Activities with Telephone and Cable Companies

National Grid Construction Activities commence

- 4.3.7 Contractors, builders and land developers are advised to seek additional information and requirements concerning National Grid Energy's construction process by becoming familiar with Appendix J of this book.
- 4.3.8 Additional information regarding RUD and CIPUD installations may be obtained, by consulting LIPA's Rules and Regulations for Electric Installations, also known as the "Red" Book.
- 4.3.9 Table 4.2 lists some common causes of design/construction delays in the hope that by identifying them here, contractors, builders and land developers will be able to avoid and minimize construction delays:

**TABLE 4.2**

**CONSTRUCTION DELAYS/REMEDIES**

<b>TYPE OF DELAY</b>	<b>REMEDY</b>
Incomplete information from builder	Builder to follow the guidelines as stated in the pre-construction requirements
Awaiting payment of charges	Send payment for all charges associated with the subdivision in accordance with the pre-construction requirements
Design Change	Builder to notify National Grid in advance of any potential project revisions
No street opening permit	Allow National Grid three to four weeks prior to the start of installation of facilities to obtain necessary road opening permits
Proper grade not established	Established grade in the roadway area should be within six inches of final grade to ensure installation of facilities at the proper depth
Property line not clearly marked	Place stakes and/or spray paint property lines at curbs to ensure proper installation of facilities
Prolonged periods of inclement weather	Builder to allow sufficient time in the work schedule for potential weather related delays. National Grid's rules and work methods prohibit the installation of electric/gas facilities under non-emergency conditions during inclement weather.

- 4.3.10 Table 4.3 is a checklist that the Builder/Land Developer can use to ensure that all requirements necessary for the design and construction of the RUD subdivision have been submitted to National Grid. Use of this list will help to avoid problems identified in Section 4.3.9.

**TABLE 4.3**  
**RUD CHECKLIST**

	REQUIREMENTS COMPLETED	DATE
1	Submitted completed "Request for LIPA UNDERGROUND ELECTRIC INSTALLATION" form.	
2	Submitted completed "National Grid Gas Request" form, if applicable.	
3	Submitted six copies of an approved subdivision map to National Grid Energy.	
4	Submitted completed "National Grid REQUEST FOR EASEMENT INFORMATION" form.	
5	Submitted payment for additions charges associated with relocation of National Grid facilities, if applicable.	
6	Submitted 10% design payment (builder only).	
7	Submitted the signed Gas Waiver Agreement if applicable.	
8	Submitted 40% material payment (builder only).	
9	Submitted 50% construction payment (builder only).	
10	Submitted 100% payment (land developer only).	
11	Submitted subdivision easement, notarized and signed by the property owner.	
12	Notified National Grid of the installation of curbs and all other proposed underground facilities.	
13	Notified National Grid that a clear unobstructed easement route of right-of-way, graded to within six inches of final grade has been provided.	
14	Submitted a completed Application Card for each home/dwelling unit requiring gas and/or electric service or (one completed application card with a complete listing of all units including lot numbers and street names) along with a completed Temporary Electrical Inspection Certificate and Gas Inspection Certificate, if applicable.	

## 5.0 GAS SERVICE LINE(S)

### 5.1 GAS SERVICE LINE(S) TO A BUILDING OR OTHER GAS USAGE

- 5.1.1 National Grid will normally provide only one gas service to a building, unless the need for more than one service is deemed necessary by National Grid. Depending on the locality, more than one service to a building may require approval from the local authority. See 5.1.3.
- 5.1.2 If National Grid determines that more than one gas service is required to supply gas to a building, the local codes may require that the structure be built using party walls to isolate each area served by a gas service.
- 5.1.3 In Long Island, when more than one gas service is installed in a building, a permanent, weather resistant placard shall be prominently placed at each meter location to identify the number of services to the fire department when isolation

of the gas service is required. It is the contractor's responsibility to provide for the installation of, and the customer's responsibility to maintain, the placard.

## 5.2 LOCATION OF GAS SERVICE LINE(S)/LATERAL(S)

- 5.2.1 For new construction, National Grid will install gas service piping in areas free of paved driveways or other paved areas. If it becomes necessary to locate a gas service line where it will be under a driveway or walk, the contractor shall not pave the driveway or walk until the gas service line has been installed. Alternately, the customer may opt to install a sleeve a minimum of 18" below grade in the area to be paved through which the gas service can be installed after the paving installation. This should first be discussed with National Grid who will advise the correct size sleeve and location, and obtain approval for the installation.
- 5.2.2 The contractor shall notify National Grid as early as possible of any such paving as indicated in Section 5.3.1.
- 5.2.3 A **new** gas service line **should** not be installed under or through buildings, unless no other feasible option exists. Where it is deemed prudent to install a gas service under a building (e.g., an enclosed porch, or similar enclosed areas occupied by people), National Grid shall install the service through a continuous steel sleeve, extending one foot on either side of the enclosure above it. The sleeve shall be sealed against water intrusion and vented to the atmosphere.
- 5.2.4 National Grid shall designate the exact location of the meter and service riser.
- 5.2.5 Any change requested by the customer to the location of an existing service line, if approved by National Grid, **shall be made at the expense of the customer**. The customer shall be responsible for hiring a contractor to install gas house line piping, meter header, regulator vent piping and/or interconnections with facilities.

## 5.3 SERVICE ENTRANCE TO EXISTING BUILDINGS

- 5.3.1 Where the service enters the building underground through a poured concrete wall, a sleeve for the gas service shall be installed by the builder during construction. Technical Lead shall designate the size and location of the sleeve. For further information, see **National Grid** Construction Standard SERV6215.
- 5.3.2 Service Entry to Existing Buildings - Where an inside meter location has been selected, the gas service entry point below grade shall be enclosed in a protective pipe sleeve following specification. The boring of the entrance hole, excavation, installing the sleeve and, sealing of the space between the sleeve and gas piping, shall be the responsibility of National Grid.

## 5.4 SERVICE TERMINATION POINT

- 5.4.1 The connection point of service (that point in the gas service line where responsibility ends and the customer's responsibility begins) shall be defined **physically** according to the applicable Construction Standard.

## 5.5 RESTORATION ON PRIVATE PROPERTY



- 5.5.1 For private property an agreement will be made before work begins on the restoration of the property. The amount of restoration performed by National Grid will be determined on a case by case basis.

## 5.6 ADDITIONAL METERS OR SERVICES

- 5.6.1 Contractors and customers are advised that **in NYC, and** some towns and other local jurisdictions require, by law, that they be notified in writing of the addition of any gas meters or new gas services to any property. It is the contractor's responsibility to become aware of these concerns and requirements.

## 6.0 GAS PRESSURE

### 6.1 NOMINAL METER OUTLET PRESSURE WHEN SERVED FROM HIGH PRESSURE DISTRIBUTION SYSTEM

- 6.1.1 On the high pressure portion of its distribution systems, where a service regulator is installed in conjunction with the gas meter, National Grid provides gas to customers at a nominal pressure of **6"** W.C. The nominal pressure is measured immediately downstream of gas meter or service regulator, whichever is further downstream.
- 6.1.2 **Operating/Running** pressure at the meter or regulator outlet typically can be as high as 7" W.C. or as low as 5" W. C. and can vary slightly for each installation depending on load diversity, pressure drops through the meter set piping, service regulator performance, and pressure drop through the gas meter.
- 6.1.3 When purchasing gas utilization equipment to operate on gas from high pressure distribution system, it is recommended that equipment be chosen to function effectively based on nominal pressure of 6" W. C. at the outlet of the meter or service regulator, whichever is further downstream.
- 6.1.4 On elevated pressure systems of over 14"w.c., all regulators must be vented outside the building to atmosphere. On services supplying 14"w.c. and less, regulators with valve bodies 1-1/4" and larger must be vented outside the building to atmosphere. Regulators with valve bodies smaller than 1-1/4" and those installed on services supplying 14"w.c. and less may be equipped with approved appliance vent limiters in lieu of outside venting. The Siemens SKP series of combination valve/regulator (with integral vent limiter) or approved equal may be utilized for their rated pressures and body sizes when installed as per this specification.

### **NOTE**

***It is policy, whenever practicable, to deliver the minimum meter outlet pressure to meet the requirements of the customer's gas utilization equipment to ensure safe, efficient operation of all properly adjusted appliances. In all cases, National Grid has the sole responsibility for the determination of which gas distribution system, low pressure or high pressure, will supply the approved load and what gas pressure can be supplied.***

## 6.2 METER OUTLET PRESSURE WHEN SERVED FROM NATIONAL GRID LOW PRESSURE DISTRIBUTION SYSTEM

- 6.2.1 On the low pressure portion of its distribution systems, where no service regulator is installed, National Grid provides gas to customers at the front wall (point of entry) of pressure that can vary between 4" and 9.5" W. C. When purchasing gas utilization equipment to operate on gas from low pressure distribution system, it is recommended that the equipment be chosen which requires no more than 3.5 W.C. pressure at the burner.

## 6.3 PRESSURE AND CONTRACTOR

- 6.3.1 The contractor shall ensure that the customer's house line and all associated interconnecting piping into system are properly sized to prevent excessive pressure losses at the gas utilization equipment. The contractor must also ensure that the customer's installed gas utilization equipment is compatible with available nominal gas pressure.

## 6.4 ELEVATED METER OUTLET PRESSURE ON HIGH PRESSURE DISTRIBUTION SYSTEM

- 6.4.1 In certain instances, such as with industrial processing or commercial equipment, there may be a need for gas pressure higher than nominal 6" W.C. at the meter outlet.

**Elevated pressures are not available throughout the entire service territory, thus all requests for elevated pressure must be approved in advance by the National Grid.**

**Customers requiring elevated pressure for the sole purpose of downsizing the houseline must be approved in advance by National Grid. There are Code, Metering, Gas Flow and Gas Pressure Regulation factors that need to be evaluated.**

- 6.4.2 If elevated pressure is requested, National Grid will normally supply gas pressures of 1/2 PSIG or more in increments of 1/2 PSIG for commercial and industrial customers. National Grid will supply elevated pressure to a customer on a case by case basis. Please note that special permission may be required from local authority having jurisdiction in certain situations.
- Fixed factor metering will be used for 1/2 PSIG metering applications.
  - Pressures of 1 PSIG or greater require instrumentation.
  - Metering applications up to 1 PSIG may utilize threaded piping and fittings.
  - Metering applications at pressures greater than 1 psig MUST utilize welded headers
  - Meter headers will be welded by National Grid at the Customer's expense (Long Island Only).
- 6.4.3 **If the customer needs elevated pressure because of gas utilization equipment requirements, the customer or customer's contractor shall provide the appropriate information in writing to support the elevated pressure request.**

**This information shall be submitted to National Grid as soon as possible for evaluation and approval.**

- 6.4.4 Along with the customer's application, the customer shall provide National Grid with the manufacturer's specifications for the gas utilization equipment. The literature furnished shall provide an explanation of the need for elevated gas pressure requirements. Upon verification of the equipment pressure requirement, if the above acceptance criteria are met and the National Grid gas system at the location can supply the elevated pressure, National Grid will furnish gas to accommodate the higher pressure need.
- 6.4.5 The customer shall be responsible to pay for any additional costs associated with the fabrication and installation of National Grid supplied welded meter headers (LI Only).
- 6.4.6 The minimum design pressure in high pressure distribution system varies depending on differing loads and weather conditions, as well as normal periodic maintenance within system. These factors can cause occasional periods of low gas pressure in the customer's house line. Therefore, it is policy to supply gas at the meter outlet or regulator of a value no greater than the *minimum* pressure of high pressure gas main serving that area.

**NOTE**

**Customers, Owners and/or Contractors shall contact National Grid if they are planning to make any additions or modifications to a gas piping system so that National Grid may provide a safety review of your plans.**

- 6.4.7 Under certain conditions where the customer's load requirements and gas utilization equipment qualify, National Grid will discuss with the customer the availability of supplying line pressure where there is no service regulator at the meter header. In these cases, the customer is advised that the gas pressure would vary nominally with any variations in high pressure gas distribution system.

**6.5 ELEVATED METER OUTLET PRESSURE ON LOW PRESSURE DISTRIBUTION SYSTEM**

- 6.5.1 In certain geographical locations, only low pressure gas is available via gas distribution system. In these areas, if elevated meter outlet pressure is required, a gas booster may be necessary. Contact National Grid for details.

**6.6 LOCAL CODES RELATING TO ELEVATED GAS PRESSURES**

- 6.6.1 When gas pressure greater than the nominal 6" W.C. is required, the code requirements of the prevailing jurisdiction shall also be met. Contractors shall be familiar with these codes and obtain any necessary approvals from regulating agencies before submitting the application to National Grid.

**7.0 METERS AND REGULATORS**

## 7.1 PREREQUISITES AND NOTIFICATIONS FOR NEW GAS METERS

- 7.1.1 At least one gas appliance, properly installed and connected to the gas piping system, is required as a prerequisite before National Grid will install a new meter and turn on the gas supply to the customer.
- 7.1.2 For all commercial, industrial and multi-family installations, a contact must be made to the **National Grid Gas Sales Team** as early as possible in the job process prior to commencement of work. The purpose of this contact is to:
- Review construction schedule and to fix commitment dates.
  - Review the service installation construction requirements.
  - Review meter header location site and meter set construction specifications
  - Review inspection requirements.
  - Review with contractor National Grid supplied construction items.
  - If applicable, review TC2014 Requirements for Installation of Automatic Dual Fuel Burners and Equipment at Temperature Controlled (TC) Sites (Blue Book Part 2 of this book).

## 7.2. METER SET LOCATION REQUIREMENTS

- 7.2.1 All meter sets shall be located on the outside of any building unless it is impractical or unsafe.
- 7.2.2 All meter sets shall be installed following the clearance requirements indicated in **the appropriate Construction Standard. For information on distances of electric meters from gas meters, refer to 020013-CS.**
- 7.2.3 Outside and inside gas shut-off valves shall be readily accessible at all times to National Grid and emergency service personnel and shall not be covered or obstructed.
- 7.2.4 The installation of meter sets in driveways, under windows, under building overhangs or near fresh air intakes ***should be avoided*** where practical. In those cases where the regulator vent cannot be located to meet clearance requirements, the contractor shall be responsible for installing regulator vent piping according to **020013-CS.**
- 7.2.5 Meter set locations shall be sufficiently removed or separated from the bottom termination of a stairway so as not to constitute a hazard. When required distances cannot be maintained, such as for buildings with limited width, the contractor shall be required to provide suitable protection.
- 7.2.6 Outdoor and indoor meter set locations that may be exposed to vehicular or other equipment damage shall be avoided unless no other feasible location exists. If one or more of the criteria in Section 7.7 of this book are met, protection posts

shall be required. National Grid, or the contractor installing the service shall provide protection posts protecting the service at the time the riser is installed. The customer will supply and install all protection posts to protect all piping downstream of the riser. Protection posts are in be installed per **National Grid Construction Standard MTRS-6060**.

- 7.2.7 Meter sets shall not be installed below ground in **vaults without National Grid approval**.
- 7.2.8 The metering of large quantities of gas or the installation of meter sets and regulators in schools, commercial buildings or industrial buildings, including multiple meter headers, may require meter rooms, or special construction or piping. Consultants and installers of such facilities are advised to consult with **National Grid**.
- 7.2.9 Although it is not desirable and should be avoided, gas meters may be placed under windows provided that the following conditions are met: **See 020013-CS**
- No other suitable location is available
  - Proper regulator venting is provided

### 7.3 INSTALLATION AND INTERCONNECTION REQUIREMENT

- 7.3.1 The meter header shall be installed according to the **National Grid** construction standard.

#### **NOTE**

*To avoid delays and possible repeat visits to the site, it is critical that the contractor adhere to the space dimensions specified between meter connections. Consult the appropriate Construction Standard for these dimensions prior to the start of construction.*

#### 7.3.2 **FOR NYC:**

The fabrication of meter headers on all commercial, industrial and multi family establishments will be the responsibility of the contractor regardless of customer's downstream utilization pressure. National Grid will be responsible to supply the plumber or contractor with the materials detailed in National Grid Construction Standards. A review of the material list in the Construction Standards will indicate the items supplied by National Grid and those to be purchased by the Plumber/Contractor. The contractor will be responsible to supply the labor to fabricate the meter header on site.

#### **FOR LONG ISLAND:**

The fabrication of meter headers is as follows:

For gas headers requiring 1 psig or less, the Contractor may elect to install the header using screw fittings up to and including 4" diameter (see National Fuel Gas Code section 5.6.8.4). For headers requiring above 1 PSIG delivery pressure, the gas header will be welded and installed by National Grid at the cost

to the Contractor or customer. Pricing will be determined by the size of the gas header.

- 7.3.3 National Grid will supply and install, at the time of meter installation, the meter swivels, nuts, bolts, and gaskets required to connect the meter to the meter header.
- 7.3.4 On all meter headers, the contractor shall be responsible for houseline interconnections with facilities and the installation of the regulator vent and/or relief valve vent piping. Houseline interconnection to the meter set and the installation of service regulator or relief valve venting shall be performed according to National Grid specifications as provided in the appropriate **National Grid** construction standard(s).
- 7.3.5 Construction Standards contain a Bill of Material and a Notes section identifying the responsibilities for furnishing various components as well as other specific requirements. Dimensions shown on the drawings shall be maintained, unless a unique installation problem develops. Exceptions to the approved construction standards shall be reviewed and approved. Contractors are advised that all of the **National Grid** through National Grid before the start of construction.
- 7.3.6 In certain installations, usually for horizontal meter headers or very large volume customers where standard construction drawings do not exist, the meter header will be custom designed by National Grid. Site specific drawings will be furnished for that particular installation by **National Grid**.
- 7.3.7 Piping and fittings used on outside meter sets shall be galvanized iron, welded and painted steel pipe, or screwed and painted black pipe. See Section 8.0 of this book for piping requirements regarding materials, coatings and construction. Galvanized is the preferred method in Long Island and also may be required by certain municipalities.
- 7.3.8 The customer's pipe connecting to the meter header shall be installed and supported following the **National Grid** Construction Standards, NFPA 54 FGCNYS and/or NYCFGC requirements, and the requirements identified in Section 8.0 of this book.
- 7.3.9 Prior to requesting a meter installation, the contractor shall be responsible for the installation of plugs or caps on any open ended pipe or fittings on the meter header or customer house line to prevent entry of dirt and debris ensuring the integrity of the gas piping system.

#### 7.4. INDOOR METER SET REQUIREMENTS

- 7.4.1 Meter sets shall be approved for indoor installation only when, in judgement, an outdoor installation is impractical or unsafe.
- 7.4.2 Indoor meters shall be installed according to the **National Grid** Construction Standards and written specifications provided by **National Grid**. **On all indoors meter sets, the meter and regulator must be a minimum or 36" from**

**a source of ignition. For information on distances from gas and electric meters, refer to National Grid Standard 020013-CS**

***NOTE***

***In cases where the service regulator must be installed inside the building, the service regulator and meter shall be located immediately downstream of the exposed service line valve.***

**7.5 INDOOR METER SET REQUIREMENTS FOR LARGE INSTALLATIONS**

- 7.5.1 For Buildings of Public Assembly, apartment buildings, or for construction within an apartment, industrial or commercial complex, each with a capacity of seventy-five or more persons, the following specifications shall apply when meters/regulators are installed indoors:
- Where practicable, the regulator, valves and other gas equipment shall be installed within a separate room that is designed for two-hour fire resistance and effectively sealed from the remaining space in the building. These meter rooms shall also meet all code requirements.
  - The customer shall post a notice prohibiting unauthorized persons from entering the meter room to prevent tampering. A conspicuous and permanent notice shall be posted on doors or access leading to the specific installation indicating the actions to be taken, and the telephone number of the proper person to be called, in the event a gas odor is detected. The lettering shall be of bold type, at least one inch in height, properly spaced to provide good legibility and contrast with background.
  - Gas meter rooms shall be properly ventilated, lighted, and kept free of trash and rubbish at all times. Outside air for ventilation of a meter room shall be furnished as a separate supply, and shall not be shared with any other room.
  - Meter rooms shall **not** be used for storage purposes, including building materials or equipment.
  - Meter rooms shall **not** be used in the volume calculation in determining the combustion and ventilation air available for gas utilization equipment.
- 7.5.2 For multifamily dwellings in New York City, gas meters shall not be located in the following places:
- A boiler room (other than a replacement of an existing gas meter) or other room or space containing a heating boiler;
  - Any stair well;
  - Any public hall above the basement or above the lowest story if there is no basement;

7.5.3 For a retrofit or expansion in a multifamily dwelling in New York City, where a gas meter is already installed in a boiler room, one additional gas meter may be installed provided the additional meter is:

- Installed adjacent to the existing gas meter;
- Is used in conjunction with the supply of gas for a gas fired heating boiler or a gas fired water heater used as a central source of supply heat or hot water for tenants.

## 7.6 MULTIPLE METER HEADER REQUIREMENT

7.6.1 Gas meters, along with associated customer owned piping at multiple meter locations, shall be plainly identified by the installing contractor using a metal tag or other permanent means. These **markings** shall clearly identify the building or part of the building being supplied by the piping on each meter. These **markings** shall be completed by *the* contractor before National Grid will install the gas meter and turn on the gas supply.

7.6.2 The meter header piping shall be adequately sized and shall be properly supported according to the **National Grid** Construction Standard identified and furnished to the contractor.

### *NOTE*

*Contractors are advised to ensure that the following additional information is known and approved by National Grid prior to the start of the meter set construction:*

1. *Piping manifold size*
2. *Number and size of meters*
3. *Meter by-pass requirements*
4. *Specific National Grid Construction Standard*

## 7.7 METER SET PROTECTION REQUIREMENT

7.7.1 When a customer cannot provide either an indoor or outdoor location for meters, regulators and associated piping that is free from the possibility of vehicular, equipment or other physical damage, the Customer will provide protection posts according to **National Grid** Construction Standard MTRS6060. The Customer is responsible for the installation of these posts. Such instances include locations near vehicles, or materials in motion, driveways, parking areas, storage rooms, or other similar situations. National Grid will not install the meter until this requirement is completed. National Grid will install any posts required to protect the gas riser.

7.7.2 In areas where vandalism might be anticipated, a protected meter area may be required, or meters may need to be protected by a suitable wire fence if specified by National Grid. Specified protection shall be installed according to the **National Grid** Construction Standard MTRS6525.



- 7.7.3 It is position that, when the specifications established in **National Grid Construction Standard MTRS6060** are not followed, National Grid will not set the new meter until adequate protection is provided.

#### 7.8 METER HEADER PAD REQUIREMENTS FOR LARGE GAS INSTALLATIONS

- 7.8.1 The customer shall be responsible for the installation of a concrete gas meter pad for all rotary and turbine meter installations where a meter pad is required. Meter pads are required to support the weight of the meter and its associated gas header piping, valves and in some cases the weight of gas house line interconnection piping.

#### 7.9 WALLS TO SUPPORT METER HEADER REQUIREMENTS

- 7.9.1 Vertical meter headers may not require a wall to support the piping, meter, and regulator.
- 7.9.2 In cases where **National Grid Construction Standards** shows meter set piping supported by a wall, a wall shall be constructed to support the meter set if one does not already exist. In some cases, where a wall does not exist, a horizontal meter set may be specified instead if space requirements are adequate.

#### 7.10 RELOCATION OF GAS METER SETS AND SERVICE LINES

- 7.10.1 Gas meter or service line relocation, such as moving a meter from one outdoor location to another outdoor location, or from an inside location to an outdoor location, shall be performed at the customer's expense. It is National Grid policy to avoid moving any inside meter to another inside location.
- 7.10.2 To request meter relocation, contact National Grid for Long Island at **1-516 545-4943, or 718-270-0220** for NY City. A **representative** will schedule a field visit by National Grid who oversees the design, policy requirements, field measurements and scheduling.
- 7.10.3 Contractors performing the relocation of the customer owned-piping shall be responsible for:
- Interconnection of piping with the National Grid piping at the connection point of service
  - Fabricate new meter header
  - Providing proper meter header protection, if needed;
  - Obtaining necessary piping permits from local authorities.

#### 7.11 GAS SERVICE REGULATOR AND VENTING REQUIREMENTS

- 7.11.1 National Grid will select, furnish or install, and adjust all service regulators when the gas is supplied by high pressure gas distribution system. All questions related to regulator and relief valve set points shall be referred to National Grid

- 7.11.2 All service regulator vent piping and related components shall be installed according to NFPA-54, FGCNYS or the NYCFGC. Contractors shall be responsible for piping the regulator vent; service regulator.
- 7.11.3 **OUTSIDE METER SETS:**  
Service regulator vent piping shall be sized according to Appendix A of this book. On all large jobs the contractor shall not size or determine the termination locations of regulator and relief valve vents without the assistance of National Grid's Project Manager or Gas Technician.
- 7.11.4 **INDOOR METER SETS:**  
All service regulators and relief valves installed indoors shall have the vent piped to the outdoors by the contractor. All regulator vent installations shall be in compliance with the **National Grid** Construction Standard Number 020013-CS **National Grid** Construction Standards and other unique requirements applicable to a particular installation shall be strictly followed by the contractor.
- 7.11.5 All vent lines on indoor or outdoor installations shall have an insulating **fitting** installed as close to the service regulator or relief valve as practical.
- 7.11.6 All vent lines on indoor or outdoor installations shall be equipped with an approved insect and rain resistant cap on the terminal end.
- 7.11.7 Service regulator vents shall not be covered over, plugged up, or otherwise obstructed.
- 7.11.8 Termination locations of regulator or relief valve vents shall be protected from damage caused by submergence in areas where flooding or ice accumulation may occur. National Grid will advise the contractor of vent terminus requirements for all locations that deviate from established requirements in the construction standards. In areas where frequent flooding occurs, the vent **shall** terminate above the high-water mark.
- 7.11.9 The lengths of vent run and number of fittings shall be kept to a minimum. It will be necessary to increase the pipe size of the vent piping when long runs cannot be avoided. Appendix A shall be consulted to decide appropriate vent sizes and other information on service regulator venting.

## 7.12 METER BYPASS REQUIREMENTS

- 7.12.1 National Grid will specify a meter bypass piping arrangement as part of the applicable construction standard design.

## 7.13 TELEMETERING INSTALLATION REQUIREMENTS

- 7.13.1 Customers with TC & Interruptible rate classification shall be remotely monitored using telemetering equipment. This requirement may result in additional cost to the customer.
- 7.13.2 The customer shall be responsible for the installation of a dedicated phone line (where required) routed to a location designated by National Grid, terminating with an appropriate network interface.
- 7.13.3 The customer shall be responsible for any trenching, drilling, conduits, restoration, supports, etc. that may be required to reach the National Grid telemetering device.
- 7.13.4 National Grid will install the interconnecting cable between the customer-provided interface and the telemetering device.

#### 7.14 METER INSTALLATION, PURGING AND RELIGHTING

- 7.14.1 For commercial, industrial and multi-meter installations that add loads requiring increased meter or regulator size where National Grid is required to shut down the existing gas service, the contractor may be required to purge air from the system upon reconnection, and to relight all gas utilization equipment affected **by the shutdown.**
- 7.14.2 For all commercial new meter sets, the installing contractor shall be responsible for purging the house line and for starting up the equipment.
- 7.14.3 For residential new meter sets, National Grid will purge the gas piping system and light all operating gas appliances at the time of the new meter set. Appliances that are not ready for operation at the time of the meter set shall be started up by the installing contractor.
- 7.14.4 Where the gas service is turned off for Company purposes, National Grid will be responsible for the turning off all affected appliances, performing an integrity test of the gas piping system prior to the turning on and gassing in, and relighting all affected appliances.
- 7.14.5 For new meter sets serving large input gas utilization equipment, the burner installer shall be responsible for purging **as per NFPA 54, FGCNYS or the NYCFGC instructions.**

#### 7.15 PILOT GAS SUPPLY FOR INTERRUPTIBLE RATE CUSTOMERS

- 7.15.1 TC & Interruptible customers who do not have an existing firm rate meter supplying a gas pilot may not be required to have a separate firm rate meter for the purpose of supplying the pilot as long as National Grid determines that installing a separate pilot gas supply line is impractical. The pilot gas supply may be taken off the interruptible gas meter supply line.

- 7.15.2 For new installations requiring a separate gas pilot supply line, the pilot gas supply shall be supplied by a low-pressure firm rate gas meter.

## 8.0 CUSTOMER-OWNED GAS PIPING SYSTEMS

### 8.1 GENERAL

- 8.1.1 Before proceeding with the design and installation of gas piping systems, contractors are advised to refer to the National Fuel Gas Code (NFPA 54), FGCNYS or the NYCFGC. It is strongly recommended that a review of the local plumbing requirements also be performed to ensure that the proposed installation is in compliance with local codes.
- 8.1.2 When a new appliance or other gas load is added to an existing gas piping system, the contractor/customer shall verify the capacity of the existing piping for adequacy according to the capacity table(s) in NFPA 54, FGCNYS or the NYCFGC or equivalent. If necessary, existing gas piping shall be replaced with larger piping or additional piping installed that also conforms to the NFPA 54, FGCNYS or NYCFGC capacity tables.
- 8.1.3 The customer shall not be permitted to use an abandoned service line as a houseline.
- 8.1.4 For Long Island installations, the licensed plumber is required to complete the Installation's integrity test by completing the form in Appendix E (This Affidavit only applies to Towns without plumbing inspectors). This completed form, along with diagram of any buried piping, will be required at the site prior to the installation of the gas meter by National Grid personnel. It is the Contractor's responsibility to install customer owned piping to all National Grid's requirements and to Federal, State and Local Codes. Failure to comply with these Codes, may delay the gassing in of the installation. National Grid will reserve the right to request and witness pressure tests for commercial installations where Town Inspectors are unavailable and the installation would classify as a "Building of Public assembly being 75 persons or more".
- 8.1.5 For customer-owned gas piping installations *that meet the definition of a gas service*, the contractor shall perform an acceptance test to verify the condition of the cathodic protection measures installed, where the type of piping warrants such protection. This test, which shall be performed after installation of the pipe and prior to setting of the meter, only indicates the condition of the cathodic protection at the time of testing. Any corrective action required by virtue of the test results shall be the contractor's responsibility. National Grid reserves the right to perform a cathodic protection acceptance test on any given installation.
- 8.1.6 Gas Pipe Bonding: "Each above ground portion of a gas piping system that is likely to become energized shall be electrically continuous and bonded to an effective ground fault current path. Gas piping shall be considered to be bonded where it is connected to gas utilization equipment that is connected to the equipment grounding conductor of the current supplying that equipment".

### 8.2 PIPE SIZING

- 8.2.1 All gas piping, including trunk and branch lines, shall be adequately sized according to the National Fuel Gas Code (NFPA 54), NYCFGC or the NYCFGC. Gas Ranges shall have a minimum pipe size of ¾" nominal size.
- 8.2.2 A diversity factor shall be used to determine the maximum gas consumption for commercial and industrial establishments and in multiple tenant buildings where several appliances or loads are supplied from a common gas pipe line. In these cases, using a diversity factor in sizing the piping can result in significant savings in houseline and meter header costs. These factors can involve some complexity. For example, surveys have shown that different usages affect the load patterns where ranges are used, but range usage does not affect heating load patterns.
- 8.2.3 For special cases (such as the standard residential combination of a boiler, a water heater and a range), a valid indication of whether the house piping system is sized properly is a series of pressure measurements taken immediately upstream of each appliance with *all* appliances operating. ***If each appliance delivers its rated input, and the minimum inlet pressure required by the manufacturer is maintained, this piping will be accepted by the National Grid representative.***

For multiple appliance or load situations, such as apartment buildings or industrial complexes with many different loads, this criterion will not hold true because of the effect of diversity factors.

***NOTE: The gas piping after National Grid's gas regulator must be immediately expanded to the customer's houseline. In addition, no elbows or valves shall be installed within 7 pipe diameters of the regulator. Failure to follow this requirement may result in pulsation, vibrations and/or pressure problems of the gas supply***

### 8.3 PIPING DRAWING

- 8.3.1 For buried customer-owned piping installations, where the supply line is defined as a service, such as a remote meter location, it is mandatory that a piping drawing or plan be provided to National Grid for review and approval prior to starting work on a job. This drawing shall indicate the proposed location, sizes of each branch, the various loads, connection point or service, cathodic protection measures, piping material and joining methods. It is especially important that the piping location information provided be accurate. At the end of the job, an as-built version of this drawing shall be submitted to National Grid prior to acceptance of the job.

### 8.4 GAS PIPING MATERIALS

#### 8.4.1 GENERAL

Materials used for gas piping shall be selected according to the provisions of NFPA 54, FGCNYS or the NYCFGC, local codes and the requirements listed in the following sections.

#### 8.4.2 GAS PIPING MATERIALS, INDOORS

For indoor gas piping, materials used shall be one or a combination of the following, complying with the latest ANSI standards for steel pipe, ANSI B36.10:

- Steel pipe must be standard weight (Schedule 40) with screwed or welded joints. ASTM A53 or ASTM 106 shall be used as a minimum.
- Galvanized pipe, of standard weight (Schedule 40), ASTM A53, with screwed joints.
- Threaded gas fittings for steel or wrought iron pipe shall be 150 pound, malleable iron, forged steel, black iron or galvanized steel.
- **Copper** tubing of any type is **prohibited** for indoor use.
- **Plastic** pipe of any type is **prohibited** for indoor use.
- **Cast iron** pipe is **not permitted** under any circumstances.
- **Corrugated Stainless Steel Tubing**: For natural gas piping inside and outside buildings, a recently developed system of piping Corrugated Stainless Steel Tubing (CSST) has been recognized by the National Fuel Gas Code since 1988, and is becoming more popular outside service territory. Corrugated Stainless Steel tubing provides another option for gas piping in addition to steel. It is to be used where permitted by local codes. (**Currently prohibited in NYC**). See Appendix F for CSST piping in all other areas of New York State

#### *NOTE*

*Contractors are advised to exercise extreme caution when choosing to use CSST on an installation since some jurisdictions may not have approved this piping option. Contractors and builders interested in learning more about this economically favorable alternative are strongly encouraged to review the relevant sections in NFPA-54, FGCNYS or the NYCFGC.*

#### 8.4.3 GAS PIPING MATERIALS, OUTDOORS, ABOVE GROUND

- For piping outdoors, above ground, including regulator vent piping, galvanized pipe or **properly coated black steel pipe** with screwed joints shall be used. **On Long Island galvanized pipe and fittings are strongly preferred on gas piping and vent lines and are a requirement in some to towns.**
- Where welded joints are required, ASTM A53 continuous weld pipe shall be used as a minimum, but ASTM A106 is recommended.
- **Cast iron** pipe is **not permitted** under any circumstances.

#### 8.4.4 GAS PIPING MATERIALS, BELOW GROUND, GENERAL

For buried customer-owned gas piping applications, only three materials, properly installed according to the specifications in the **book**, are acceptable. These materials are:

- Coated steel pipe with a cathodic protection system to prevent corrosion. Steel pipe construction may be either welded or threaded. See Section 8.4.5 for details.
- Polyethylene (PE) plastic piping. Plastic piping is the material of choice for gas utilities because it is low in cost, easy to handle and install, and is noncorrosive underground. See Section 8.4.6 for details.
- Copper tubing with brazed or flared joints for *only certain specific small load applications only*, such as gas grills and gas lights. See Section 8.4.7 for details. **(Not approved for use in NYC service territory).**
- *Cast iron pipe is not permitted* under any circumstances.

#### 8.4.5 GAS PIPING, BELOW GROUND, STEEL PIPE OPTION

- Steel pipe shall meet the requirements of ASTM A106 or API 1104, with a minimum of schedule 40 wall thickness. This piping is commercially available with factory-applied protective coatings for buried applications (mill wrapped). Piping may be installed either by welding or by use of field threading techniques and threaded couplings. All bare sections of piping and fittings, welded or threaded, shall be field coated and wrapped according to the coating and wrapping techniques of Section 8.10 of this book.

In addition, a cathodically protected system shall be required for steel pipe installed below ground to be fully effective in preventing corrosion.

**Uncoated steel pipe and uncoated portions of steel pipe where welded or threaded joints have been made shall not be permitted below ground.**

*Installation requirements and details for steel piping* installed below ground are provided in Sections 8.10 through 8.11.

#### 8.4.6 GAS PIPING BELOW GROUND, PLASTIC PIPE OPTION

Polyethylene (PE) pipe or tubing PE 2406 (medium density yellow) or PE 3408 (high density black) conforming to ASTM D2513, Specifications for Thermoplastic Gas Pressure Pipe Systems, shall be used.

PE plastic pipe may *not* be used for gas piping inside or beneath buildings (unless approved by National Grid) or for venting gas pressure regulators.

The following specifications shall be used for PE fittings:

- ASTM D2683 Specification for Socket Type Polyethylene Fittings for Outside Diameter Controlled PE Pipe and Tubing
- ASTM D3261 Specification for Butt Fusion Polyethylene (PE) Plastic Fittings for Polyethylene (PE) Plastic Pipe and Tubing
- ASTM F1055 Standard Specification for Electrofusion Type PE Fittings for Outside Diameter Controlled PE Pipe and Tubing

**NOTE:**

*All PE pipe, tubing and fittings are normally marked by the manufacturers with the appropriate ASTM code-indicating conformance to the specified standards.*

*Installation requirements and details for plastic piping are provided in Section 8.12*

**TABLE 8.1**

**PLASTIC PIPE SDR RATINGS AND WALL THICKNESSES**

SIZE	SDR RATING	WALL THICKNESS
½" CTS	SDR 7	.090"
1" CTS	SDR 11.5	.099"
1 ¼"	SDR 10	.166"
2"	SDR 11	.216"

**8.4.7 GAS PIPING BELOW GROUND, COPPER TUBING OPTION**

Minimum wall thickness when using copper shall be as specified for type "K" or "L" tubing, according to ASTM B88, soft copper.

- Fittings for copper tubing shall be wrought copper. Cast fittings are not permitted. See Section 8.13 for copper installations.

**NOTE**

*Copper tubing shall not be used above or below ground from the meter outlet to the building foundation, such as from remote meter pad locations, under the building foundation, or through the building wall. Installation requirements and details for copper tubing installed below ground are provided in Section 8.13.*

**8.5 VALVES**



- 8.5.1 Listed, design-certified manual shut-off valves shall be used as main shut-offs for gas appliance installations according to the requirements in NFPA-54, FGCNYS, or the NYCFGC **and local codes**.

**CAUTION**

***NEVER - FOR ANY REASON - remove the core nut from a gas valve, or attempt to disassemble a valve stem when the gas pressure is on.***

8.6 STEEL GAS PIPING, WELDING REQUIREMENTS

8.6.1 GENERAL

When welded construction is used, above or below ground, indoors or outdoors, welders shall be certified by recognized certification and testing agencies for pipeline welding in accordance with API 1104 or ASME Section IX. Written welding procedures shall be followed to ensure the acceptability of field welds. Welders' certifications shall be available at the construction site.

8.6.2 RESIDENTIAL, COMMERCIAL, INDUSTRIAL, MULTI-FAMILY INSTALLATIONS IN NEW YORK CITY, NASSAU AND SUFFOLK COUNTIES

IN LONG ISLAND:

The maximum design/operating pressure for gas piping systems located inside buildings shall not exceed **5 psig** unless: 1. Approved by National Grid. 2. The piping system is welded **and one or more** of the following **conditions** are met:

- The piping is located in a ventilated chase or otherwise enclosed for protection against accidental gas accumulation.
- The piping is located inside buildings or separate areas of buildings used exclusively for:
  - Industrial processing or heating,
  - Research,
  - Warehousing, or
  - Boiler or mechanical equipment rooms.
- The piping is a temporary installation for buildings under construction.
- The piping serves appliances or equipment used for agricultural purposes.

IN NEW YORK CITY:

No gas distribution piping containing gas at a pressure in excess of 1/2 psig shall

be run within a building, except that pressure not exceeding three (3) psig is permitted for the following uses: (a) commercial use, (b) industrial use; (c) other large volume use in which fuel requirements for boiler room equipment exceed 4000 cubic feet per hour and such large volume use is supplied through separate gas distribution piping to the boiler room. Gas pressure not exceeding 15 psig is permitted for boiler room equipment in excess of 100,000 cubic feet per hour provided the gas distribution piping is installed as provided for in Section P115.8 of the New York City Building Codes. The use of pressure in excess of 15 psig shall be permitted for distribution piping provided all of the requirements of Section P115.8 are met.

All requirements for installation of gas distribution piping with pressure above 1/2 psig shall be in accordance with Z223.1 Part II National Fuel Gas Code. Gas distribution piping operating at a pressure of over 1/2 psig to 3 psig and of a size 4 inches or larger shall be welded. All gas distribution piping operating at a pressure above 3 psig shall be welded and radiographed per API-1104 or ASME Section IX. All welding of gas distribution piping shall be subject to controlled inspection as set forth in section C26-103.3.

Threaded piping may be used up to 4 inches in size at pressures no greater than 1/2 psi.

### 8.6.3 ALL PUBLIC AND PRIVATE SCHOOL BUILDINGS, INCLUDING COLLEGES

**For New York State Schools**, refer to **the Manual of Planning Standards Section S709 F. Section S709 F states:**

1. Gas piping with a working pressure up to 12" W.C. must be welded for pipe sizes 3" and over. The completed line is to be pressure tested with air or inert gas for a minimum of one hour at 15 psig.
2. Gas piping with a working pressure above 12" W.C. must be welded for pipe sizes 3" and over. The completed line is to be pressure tested with air or inert gas for a minimum of one hour at 1/2 times the working pressure or a minimum of 50 psig.

**For New York City owned Schools**, refer to the **NY City School Construction Authority, Section 15416 – Plumbing and Drainage Section 15416. Excerpt of 15416**

1. Gas pressure in the utility's street piping network is 1/2 psig (14" w.c.) or less (inclusive of system being provided with a gas booster pump):
  - a. 4"(inches) pipe dia. and smaller . Threaded or welded
  - b. Over 4" (inches) pipe dia. . . . . Welded
2. Gas pressure in the utility's street piping network is greater than 1/2 psig but less than 15 psig (inclusive of the utility company providing a service regulator to reduce the incoming pressure to 1/2 psig):
  - a. Under 3" (inches) pipe dia. . . .Threaded or Welded
  - b. 3"(inches) and larger pipe dia. . Welded
3. Piping over 15 psig
  - a. All piping . . . . . Welded

<http://www.nycsca.org/Business/WorkingWithTheSCA/Design/Pages/Specifications.aspx>

8.6.4 FOR PRESSURE TEST REQUIREMENTS REFER TO **APPENDIX D**

8.6.5 STANDARDS FOR NON-MERCURY GAUGE

The rules in this section establish the minimum standards for non-mercury gauges to test gas piping, drainage and vent systems.

Minimum requirements – Each gauge shall meet the following requirements:

- a) The gauge shall be manufactured and used in accordance with the ASMEB40.100-1998 Standard for Pressure Gauges and Gauge Attachments, which incorporates ASME B40.1-1998 and ASME B40.7-1998, and the manufacturer shall provide with the gauge a written statement that the gauge is manufactured in accordance with such ASME standard:
- b) For test pressures for 3 to 5 psig, a 15 psi gauge with ½ psig increments shall be used. Minimum dial size shall be 3” in diameter.
- c) For test pressures greater than 5 psig, a 100 psi gauge with 2 psig increments shall be used. Minimum dial size shall be 3-1/2” diameter.
- d) The gauge shall be labeled with the name of the manufacturer;
- e) The units of measurement “psi” shall appear on the face of the gauge
- f) The gauge shall be kept in good working order and properly stored.

8.6.6 WELDER QUALIFICATIONS

- a) Welder’s qualifications. Welders installing gas piping within buildings at any pressure shall be qualified for all pipe sizes, wall thicknesses and all positions in accordance with either API 1104-1977, 14th edition, or ASME Section IX Boiler and Pressure Vessel Code, 1980 and re-qualified on an annual basis. The qualification testing shall be performed by an agency listed with the department of buildings, and the inspector shall have a minimum radiography qualification of Level II in accordance with the American Society of Non-Destructive Testing Recommended Practice Document No. SNT-TC-1A, Supplement A. Copies of the certified welder qualification reports shall be maintained by the responsible welding contractor and shall be made available to the department of buildings upon request.
- b) Welding requirements. All welded gas distribution and meter piping main and branch supplies to customer equipment operating in excess of 3 psig inside buildings shall be butt welded; and shall be subject to controlled inspection. Radiography shall be performed on all butt welds in gas meter and gas distribution piping operating at pressures exceeding 3 psig, within buildings, in accordance with API 1104-1977 or ASME Section IX Boiler and Pressure Vessel Code 1980.

- c) **Welding Requirements NYC.** In addition, to Section 8.6.6 a & b, shall be subject to special inspection in accordance with Chapter 17 of the New York City Building Code.

8.7 **GAS PIPING (INDOORS AND OUTDOORS) ABOVE GROUND, INSTALLATION REQUIREMENTS, GENERAL**

- 8.7.1 Gas piping in concealed locations shall be installed according to the requirements in NFPA-54, FGCNYS, NYCFGC **or local codes**. If it is desired to locate concealed gas piping in partitions, piping shall be located in hollow partitions, such as in ventilated chases. Concealed piping in solid partitions is prohibited.
- 8.7.2 Gas piping inside or outside of any building shall not be run in or through an air-duct, clothing chute, chimney or flue, ventilating duct, dumb waiter or elevator shaft.
- 8.7.3 No other piping or wiring shall be located in a casing containing a gas line.
- 8.7.4 Gas lines passing through concrete or masonry walls, floors or slabs shall be enclosed by a sleeve or thimble.
- 8.7.5 Gas piping extending through foundation walls shall be sleeved and sealed according to the requirements in NFPA-54, FGCNYS, **NYCFGC and local codes**
- 8.7.6 The use of gas piping as a grounding electrode is prohibited.
- 8.7.7 Sediment traps for gas piping shall be installed according to the requirements in NFPA-54, FGCNYS, NYCFGC **and local codes**. When not incorporated as part of the equipment, a sediment trap shall be installed downstream of the equipment shutoff valve (exception: dryers, ranges, outdoor grills and illuminating appliances)
- 8.7.8 Where a branch outlet is placed on a main supply line before it is known what size pipe will be connected to it, the outlet shall be of the same size as the line that supplies it.
- 8.7.9 Shutoff valves controlling several gas piping systems shall be accessible for operation and shall be installed so as to be protected from any physical damage. Gas shutoff valves shall be plainly marked with a metal tag by the installer so that each piping system supplied by the valve can be readily identified.
- 8.7.10 Gas piping shall not be supported by other piping but shall be supported directly by the building structure itself with pipe hooks, metal straps, bands, or hangers suitable for the size of the pipe, and of proper strength and quality at proper intervals so that the piping cannot be jarred or displaced accidentally from its original position.
- 8.7.11 Listed and approved flexible connectors shall be used for final connections to gas appliances provided the flexible connectors are used on moveable equipment such as gas dryers and gas ranges only, and are placed on the appliance side of

the appliance shut-off valve. Certain manufacturers of selected equipment supply flexible connectors for permanent mounted gas utilization equipment. In those cases, the manufacturer's specified flexible connectors shall be installed according to the manufacturer's installation instructions **and local codes**.

8.7.12 Flexible connectors shall not pass through floors or partitions.

8.7.13 For steel gas piping installed outdoors above ground, piping shall be protected with a suitable oil based painting system, or by use of one of the coating systems identified in Section 8.9 of this book. If galvanized pipe is used, painting is not required, but it is recommended that the exposed threads be painted.

## 8.8 GAS PIPING OUTDOORS, BELOW GROUND, INSTALLATION REQUIREMENTS

8.8.1 New York State's Public Service Commission Regulations require that buried gas piping meet their requirements. These concerns are critical because underground conditions promote corrosion. In order to comply with these laws, the materials and rules in the following sections are provided to ensure that gas piping meets the required standards.

8.8.2 For underground piping, mark-out procedures shall be strictly followed during construction according to the provisions of 16 NYCRR part 753. Prior to excavation, National Grid or its representative will mark out all gas facilities in the public right-of-way. The customer is responsible to mark out all Customer Owned gas and other utilities located on their private property. The number to call to get the facilities marked out is **811**.

8.8.3 Only personnel qualified to perform the specific pipe-joining processes used for any given installation, such as welding for steel and heat fusion for plastic, shall perform this work.

8.8.4 Remote meters are normally limited to commercial and industrial facilities where multiple buildings are supplied gas from a single meter set location. There are, however, some applications where National Grid requires that a meter be installed remotely from a building due to the inability to locate the meter inside or directly near the building. For these cases, the meter sets are, where practical, installed as close to buildings as possible so that customer piping need not be buried.

These installations, where the piping must be treated as a gas service, require special attention and piping specifications, and are addressed accordingly in Sections 8.9 through 8.14 of this book.

8.8.5 When buried piping downstream of the meter is required, the piping shall be designed and installed according to NFPA 54, FGCNYC and NYCFGC specifications. Where the National Grid Construction Standards (CS) are applicable, those drawings shall be used. When a specific Construction Standard or Construction Detail Drawing is required, the direction will come from National Grid.

8.8.6 For buildings where the gas pressure exceeds 1 psig at the point where the service line enters the building, all exterior wall openings that are both below

grade and within 10 feet of the gas service line entry point shall be made gas tight. Where such openings are provided for gas service lines, the gas pipes shall be protected from damage by settlement or corrosion.

- 8.8.7 Customer-owned gas piping shall enter buildings above grade wherever possible to avoid the additional expense of cathodic protection requirements.
- 8.8.8 Where underground installation of gas piping beneath buildings or portions of buildings is unavoidable, the piping shall be encased in a conduit. The conduit shall extend into a normally usable and accessible portion of the building, and at the point where the conduit terminates in the building, the space between the conduit and the gas piping shall be sealed to prevent the possible entrance of any gas leakage. The conduit shall extend at least 4 inches outside the building, be vented above grade to the outside, and be installed in such a way as to prevent the entrance of water. **National Grid** should be contacted for any questions or clarifications.
- 8.8.9 All piping below ground shall be installed with a minimum of 18 inches of ground cover (24" depth of cover in NYC) and clearance of 6 inches from other sub-surface facilities or materials. Where other subsurface facilities prevent the installation of gas piping at this minimum depth, the area with less cover shall be protected by a steel schedule 40 pipe casing two pipe sizes larger than the gas pipe or a 1/4" thick steel plate that extends 12" horizontally each side beyond the limits of the gas piping.
- 8.8.10 Where steel pipe is used, below grade piping and fittings shall be fully coated and cathodically protected according to National Grid Specifications as defined in Sections 8.9 through 8.11 of this book, and the National Grid Construction Standard.
- 8.8.11 Back fill around pipe shall consist of loose dirt or sand, must be free of rocks, building materials or other debris.
- 8.8.12 Where plastic pipe is used (**where code permits**), connections between metallic and plastic pipe shall be made (below grade) only with fittings approved by the pipe manufacturer. Information concerning these fittings can be obtained by contacting National Grid. The recommended ways to make this transition connection are: **See Section 8.12 for plastic pipe installations.**

Use of an approved service riser assembly;

- Use of an approved transition fitting. These fittings are couplings that have been tested and approved by National Grid based on their ability to resist longitudinal pullout forces.

- 8.8.13 For all underground piping customer/plumber/contractor shall fill out the "Customer Owned Gas Piping Certificate" form in Appendix E. The form shall be submitted to National Grid at the time the meter is delivered. This as-built drawing of the piping shall be submitted regardless of 3<sup>rd</sup> party inspection.
- 8.8.14 **All** piping shall be pressure tested according to Appendix D of this book prior to acceptance by National Grid.

## 8.9 STEEL GAS PIPING, CORROSION PROTECTION REQUIREMENTS, COATING AND WRAPPING

- 8.9.1 For steel pipe, above ground or below ground, the following information shall be used for coating and wrapping. If *bare steel pipe* (as opposed to mill wrapped pipe) is used *below ground*, the following procedures are *mandatory*. If bare steel pipe is used above ground, these procedures are optional, as opposed to use of oil based painting systems.
- 8.9.2 Steel piping shall be given a primer coating and then wrapped with a tape suitable for underground use. Do not use Electrical Tape. See National Grid Construction Standards COR02001 and 030031-CS. The pipe surface shall be clean and free of rust prior to applying the primer coat. Tape wrapping shall be spirally wound with a half overlap on each turn **it is recommended that the exposed threads be painted.**
- 8.9.3 The following materials are acceptable for coating and wrapping steel pipe:
- Polyken Technologies Pipeline Primer #1027 or equal, in conjunction with Polyken Tape #936 or equal, or Polyken Gas Utility Tape or equal.
  - Tapecoat Company CT Coldprime or equal in conjunction with Tapecoat Pipe Tape H-30 or H-50 or equal.

## 8.10 STEEL GAS PIPING, CORROSION PROTECTION REQUIREMENTS, INSULATING JOINTS

- 8.10.1 Insulating couplings or fittings shall be used to electrically separate the underground portion of steel piping from the above-ground piping or the piping in a building. The insulators shall be located on the above ground portion of a riser and on the pipe immediately after entering a building wall. No other connections shall be made to the underground portion of piping that could result in an electrical ground to the piping, since this will cause the insulators to be ineffective. Insulating unions, threaded or insulating couplings, or insulating flanges are typically used for these connections.

## 8.11 STEEL GAS PIPING, CORROSION PROTECTION REQUIREMENTS, MAGNESIUM ANODES

- 8.11.1 Magnesium anodes shall be electrically attached to the underground steel piping using a thermite welded (often called "cadweld") connection. These anodes are available in 3 pound and 17 pound ingot sizes with a wire connection lead attached.
- 8.11.2 One 3-pound anode shall be installed where the total underground piping length is 10 feet or less. When the total length of underground pipe is greater than 10 feet, install one 17-pound magnesium anode for every 100 feet of underground piping. *Note: Always bury an anode with the container it comes in. Do not remove it from the cardboard box!*

8.11.3 The anode ingot shall be buried in the soil approximately 2 feet to the side and below the level of the piping at a location near the center of the section pipe being protected.

8.11.4 The wire lead shall be attached to a bare steel area of the pipe using a thermitic weld kit, using a #15 Green Cap cartridge specifically manufactured for attachment to schedule 40 pipe. After attaching, the coating in the thermitic-welded area shall be restored (re-coated) so that no bare metal remains.

## 8.12 PLASTIC PIPING, INSTALLATION REQUIREMENTS (Where allowed by Code)

8.12.1 New York state code requires that plastic pipe and fittings shall be installed by qualified personnel according to the manufacturer's written installation instructions.

8.12.2 Before using materials, visually inspect for damage such as gouges, scratches and kinks, and discard any damaged materials.

8.12.3 PE pipe and tubing must be laid on undisturbed or well-compacted soil or other continuous support. Suitable rock-free back-fill shall always be placed around the pipe or tubing.

8.12.4 In addition to the minimum depth of coverage (18"), consideration must be given to future loading and activity above and around the piping to determine if encasing the pipe in a steel sleeve is necessary.

8.12.5 Pneumatic or mechanical tamping shall not be used within 12" of the plastic piping.

8.12.6 Pipe or tubing must be free of cuts and scratches deeper than 10% of the wall thickness. Defects in pipe, tubing or fittings cannot be repaired. Therefore, the damaged pipe, tubing or fittings must be replaced. PE pipe shall not be used inside buildings or above ground.

8.12.7 PE pipe and tubing shall be joined by heat fusion or by mechanical fittings (mechanical service head adapters).

8.12.8 Mechanical fittings shall not be used where pressure exceeds 5 psi or pipe size is greater than 4" diameter, except in certain instances where a customer-owned piping system qualifies. The preferred joining method is an all fused plastic system (electrofusion or butt fusion). PE mechanical stab and full restrained (locking) compression fittings (made for natural gas) are permitted as approved by National Grid. If a metallic mechanical fitting is used as a last resort, the mechanical coupling shall be cathodically protected from corrosion by industry approved field coating and the installation of a 3# anode.

8.12.9 Heat fusion joints shall be made according to the manufacturer's recommended heat fusion procedures.

8.12.10 Miter joints are not permitted.



- 8.12.11 Joints shall not be located in pipe bends.
- 8.12.12 See the pipe manufacturer's requirements for minimum bending radius of plastic pipe.
- 8.12.13 ***Heat fusion joints shall be performed only by personnel qualified in the appropriate joining techniques.***
- 8.12.14 A #14 AWG, minimum, insulated solid copper wire shall be installed alongside but not touching the plastic pipe to facilitate locating with a pipe locator. Tracer wires shall terminate in an accessible location above ground so that a pipe locator can be connected.
- 8.12.15 A bright-colored plastic warning tape shall be buried approximately 12" below final grade to mark the location of the pipe and to warn future excavators.
- 8.12.16 Insulating couplings or fittings shall be used to electrically separate the underground portion of plastic piping from the above-ground steel piping or the piping in a building. This is necessary to protect the gas riser, and also is necessary for anode less, pre-coated riser.
- 8.12.17 Plastic Fuel Gas Piping installations shall be performed by trained, qualified and certified personnel by National Grid.

#### 8.13 COPPER TUBING INSTALLATION REQUIREMENTS (Where allowed by Code)

The sizing of copper tubing shall be selected based upon the maximum capacity of natural gas in cubic feet per hour as specified in of NFPA-54, FGCNYS or NYCFCG.

- 8.13.1 **Fittings for copper tubing shall be wrought copper. Cast fittings are not permitted.**
- 8.13.2 Copper tubing shall not be used above or below ground from the meter outlet to the building foundation, such as from remote meter pad locations, under the building foundation, or through the building wall.
- 8.13.3 ***Soft solder joints (sweated joints) shall not be permissible.***
- 8.13.4 When mechanical joints are necessary for joining copper tubing standard SAE flared fittings shall be used.
- 8.13.5 ***Threading of copper tubing shall not be permissible.***
- 8.13.6 Insulating couplings or fittings shall be used to isolate transitions from copper to other metal piping and to electrically separate the underground portion of copper tubing with the tubing above ground or the tubing in a building.

#### 8.14 GAS PIPING THROUGH BUILDING WALLS, ABOVE OR BELOW GROUND, INSTALLATION REQUIREMENTS

- 8.14.1 That portion of customer-owned outdoor steel gas piping, **above** ground that runs through an external building wall (the wall piece) shall be coated or

wrapped using one of the coating and taping systems listed in Section 8.9.3 of this book. This requirement shall be applicable to all steel pipe, including black pipe, and to piping above ground that runs through walls. **PVC tape is not acceptable for wrapping pipe for this purpose.** If galvanized pipe is used, taping of the pipe is not required, but it is recommended that the exposed threads be painted.

- 8.14.2 For wall penetrations below ground, refer to the appropriate National Grid drawing for installation requirements and details. **Note: that a sleeve is required for this application.**

## 8.15 PRESSURE TESTING OF GAS PIPING

- 8.15.1 All pressure testing of gas piping shall be performed according to the procedure in **Appendix D** of this book.

## 9.0 GAS UTILIZATION EQUIPMENT

### 9.1 GENERAL

#### 9.1.1 APPLIANCES- ACCESSORIES AND EQUIPMENT APPROVAL

All of the gas appliances and accessories that National Grid services, and referred to in this book shall be design-certified by a nationally recognized testing and/or listing agency, such as **CSA** or Underwriters Laboratories, **M.E.A.**, to comply with the applicable American National Standard.

#### 9.1.2 INSTALLING CONTRACTOR'S RESPONSIBILITIES

The work performed by the contractor shall comply with the applicable Building Code of Nassau or Suffolk County, or the City of New York, and all departments and bureaus having jurisdiction over the installation. The contractor shall obtain all necessary permits and certifications that may be required for the job.

Requirements for gas utilization equipment, collected together in the following sections, are intended to supplement or amplify, but not substitute for, any applicable State, City, Town or Village codes, regulations or ordinances. If there is a conflict between the National Grid requirement and the municipal requirement, *the more stringent requirement will govern.*

In all cases, it is the installer's responsibility to comply with all local municipal requirements. National Grid does not assume the obligation of enforcing or inspecting for compliance with municipal code requirements.

#### 9.1.3 Carbon Monoxide (CO) ALARMS

Carbon Monoxide (CO) is a highly toxic gas. It is the product of

incomplete combustion of fossil fuels such as oil, natural gas, propane, gasoline, wood and coal. CO is very dangerous because it is colorless, odorless and tasteless.

National Grid recommends the installation of CO Alarms in accordance with applicable codes and recommends annual maintenance of the heating system.

For the correct location of CO Alarms and for the full text of the NYC and NYS CO Alarm Law, see Appendix G.

#### 9.1.4 ASSEMBLY OF EQUIPMENT

The installing contractor shall assemble the equipment according to the installation instructions of the manufacturer.

#### 9.1.5 GAS UTILIZATION EQUIPMENT INSTALLED IN RESIDENTIAL GARAGES

Gas utilization equipment installed in residential garages and in adjacent spaces that open to the garage and are not part of the living space or dwelling unit, shall be installed so that all burners and burner ignition devices are located at a minimum of 18" above the floor unless the equipment is listed as "Flammable Vapor Ignition Resistant" per NFPA-54.

#### 9.2 NATIONAL GRID "NATURAL GAS PRESSURE, IGNITION & DRAFT TEST"

On new gas meter installations National Grid will perform a natural gas pressure test (lock up & run), ignition and draft test on new natural gas utilization equipment; however, it is up to the installing contractor to insure the equipment meets the manufacturer's installation guidelines.

#### 9.3 GENERAL REQUIREMENTS, SPACE AND WATER HEATING EQUIPMENT INSTALLATIONS

9.3.1 Certified Rating plates shall be securely fastened to the appliance.

9.3.2 A complete set of manufacturer's operating, installation and maintenance instructions shall be made available.

#### 9.4 COMBUSTION, DILUTION AND VENTILATION AIR (FRESH AIR) REQUIREMENTS

9.4.1 Air for combustion, dilution and ventilation air installed in any size room shall be installed according to the requirements of NFPA-54, FGCNYS or NYCFGC.

#### 9.5 VENTING OF CATEGORY I GAS UTILIZATION EQUIPMENT ONLY

9.5.1 Venting of all equipment shall be provided according to the latest version of the National Fuel Gas code, NFPA 54, FGCNYS or NYCFGC.

- 9.5.2 For Long Island, refer to the Fuel Gas Code of New York State, Section 503.6 and NYC, refer to the New York City Fuel Gas Code for multi-story venting installations. Gas vents serving equipment on more than one floor, a single or common gas vent shall be permitted in multistory installations to vent Category I equipment located on more than one floor level, provided the venting system is designed and installed in accordance with this section and approved engineering methods.

Equipment separation. "All equipment connected to the common vent shall be located in \*rooms that do not communicate with occupiable and/or habitable spaces.

(\*rooms with outdoor access only)

- 9.5.3 Use of "Wye" connectors are recommended in all Category I venting systems. Use of a standard tee at any point in a venting system **is also acceptable**. When using either type of fitting, the body of the wye or tee shall be the same full size as the common vent. For example, in a case where two appliances are to be commonly vented, each of which require a 4" separate vent connector, and the common vent required is 6" (arrived at by using the vent tables), a 6 x 6 x 6 wye or tee using reducing collars on the two inlets is acceptable. A 4 x 4 x 4 wye or tee with a reducing collar on the common outlet is not acceptable.

9.5.3.1 A 6 x 6 x 4 tee, where the 4" size (typical for use in venting a water heater) is the bull of the tee, which allows for the main body of the tee to be the same size as the common vent, or 6" ) a 4" reducing collar would also be required on the inlet leg of the tee); or

9.5.3.2 A 6 x 6 x 4 wye, where the side connection entering at an angle is 4", but the main body of the wye is 6" (also required a 4" reducing collar on the other inlet of the wye.

- 9.5.4 **Use of draft hoods on gas designed equipment shall not be altered.**

## 9.6 VENTING OF GAS UTILIZATION EQUIPMENT - CATEGORIES II, III AND IV

- 9.6.1 Venting for Category II, III and IV equipment (as defined in NFPA 54, FGCNYS or the NYCFGC) shall be installed according to the manufacturer's installation instructions.

## 9.7 CHIMNEYS

- 9.7.1 **The contractor shall perform an inspection on the chimney venting system to ensure it confirms to nationally recognized standards.** The contractor shall not install a flue connector into a chimney breach opening that is smaller than the connector, or extend the breaching beyond the chimney lining. Under no circumstances shall this rule be violated.

- 9.7.2 For the proper sizing of vents connected into Type B Double Wall Vents, Interior and Exterior Masonry Chimneys, please follow the Venting tables listed in NFPA-54, FGCNYS or the NYCFGC. Special care must be taken when

venting new equipment into an existing exterior masonry chimney. For additional information on Venting and Combustion Air, please refer to: "Choosing a Furnace or Boiler" in Appendix B.

## 9.8 SPILL SWITCH REQUIREMENTS

- 9.8.1 A manual reset thermal cut-off device (spill switch), UL tested and approved, shall be required on all natural-draft, gas-fired equipment used for space heating; i.e., all boilers, furnaces and conversion burners. This device shall shut off the gas to the burner in the event of chimney blockage or continued back draft. It is important to note that, as of January 1, 1991, boiler manufacturers are **required** by Federal law to provide both a **spill switch and flame roll out switch** on all **new** atmospheric gas boilers and furnaces having a rating of 300,000 Btuh or less. Interpretation of this ruling is to expand the requirement for spill switches to all natural draft appliances regardless of vent size, or whether or not the appliance is installed in a residential, commercial, industrial or multi-family establishment. For gas **conversion burners** that are installed in residences and other occupancies that utilize masonry chimneys or gas vents, a manual-reset thermal spill switch is also required. Add-on spill switches shall also be UL tested and approved.

In New York City, when multiple gas appliances having inputs above 300,000 BTU's (300 CFH) are connected to a common vent/chimney, each individual Spill Switch must be electrically wired in series with each other.

## 9.9 INSTALLATION OF HEAT PRODUCING EQUIPMENT IN FLAMMABLE OR CORROSIVE ATMOSPHERES

- 9.9.1 In operations where there is use of flammable liquids or agents, or aerosol sprays using halogenated hydrocarbons such as carbon tetrachloride, special care shall be taken in the installation of heat-producing equipment. Flammable liquids clearly must be kept a significant distance away from gas burning flames for safety reasons. Not so apparent, however, halogenated hydrocarbons tend to break down in temperatures above 500 degrees F and form toxic fumes. These fumes are extremely corrosive and will accelerate damage to heatproducing equipment, flues and exposed metal surfaces.
- 9.9.2 It is imperative that all air for combustion come from out-of-doors in environments of this nature, unless the equipment can be isolated from the contaminated atmosphere.

### ***NOTE***

***NATIONAL GRID REQUESTS THAT ANY CUSTOMER WHO PLANS INSTALLATIONS IN THIS TYPE OF ATMOSPHERE CONTACT EQUIPMENT MANUFACTURER FOR TECHNICAL SUPPORT***

### ***CAUTION***

***The contractor is advised to become fully aware of the boiler control requirements as provided for in the latest revisions of ASME CSD-1 and New York State Code Rule 4.***

*These documents may require additional safety controls over and above those required by this book or as furnished standard from the manufacturer for selected commercial, industrial and multi-family establishments.*

#### 9.10 GAS CONVERSIONS AND CONVERSION BURNER REQUIREMENTS

- 9.10.1 Conversion burners and associated equipment for gas conversions shall be installed according to the burner manufacturer's installation instructions, NFPA-54, FGCNYS or the NYCFGC and ANSI Z21.8.
- 9.10.2 When installing conversion equipment, the combustion chamber and flue passage ways of the existing appliance shall be thoroughly cleaned.
- 9.10.3 Conversion burner nozzle shall not extend into combustion chamber.
- 9.10.4 Combustion chamber shall be installed on dry-base boiler if upshot gas burner is not used.
- 9.10.5 Burners shall be adequately supported, i.e., burner legs shall be required, or burner shall be resting on a firm and level foundation, where applicable.
- 9.10.6 Burners shall be properly attached to boiler flange.
- 9.10.7 Unit shall be inspected and tested for gas tightness. All openings around the boiler base at floor level, doors and at gun entrance shall be properly sealed with masonry cement or equivalent to prevent air leakage into the boiler. Clean outs and burner blast tube, except fire door, shall be sealed with non-asbestos type furnace cement.
- 9.10.8 Unless otherwise specified by the burner manufacturer, always install a gas designed **double-acting** barometric draft regulator in the vent connector. Gas designed barometric draft regulators shall be installed according to manufacturer's installation instructions (power burner only).
- A manual reset or single use type thermally actuated spill switch shall be installed on the double-acting barometric draft regulator. This switch is wired into the burner circuit to shut the gas off in case of a sustained back draft or blocked chimney condition.
- 9.10.10 Stack switches or stack aquastats shall be removed from electric circuit so they do not function as operating gas controls.
- 9.10.11 Base of chimney shall be cleaned, and the chimney wire brushed from top to bottom. If not properly cleaned, oil residue left on the gas vent will dry out over time, flake off, and drop downward, possibly building up to cause a blocked chimney condition.
- 9.10.12 Vent connector shall be properly sized. Check the existing vent connector size against the proposed firing rate of the gas burner to determine if the vent

connector is too big or small. Replace the vent connector if its size does not correspond with the vent tables in NFPA-54, FGCNYS or the NYCFGC.

- 9.10.13 Contractors are advised that gas conversion burners are not delivered adjusted for proper input and combustion air. Therefore, appropriate adjustments ***shall be made*** to ensure proper draft, proper CO readings and other items necessary for safe operation.

#### 9.11 GAS FIREPLACES (VENTED DECORATIVE GAS APPLIANCES)

- 9.11.1 In all cases, these appliances shall be installed according to applicable state codes, the manufacturer's installation instructions and other specific conditions of approval. Within New York City, the appliance shall be approved for use in the City of New York.
- 9.11.2 Existing masonry fireplace flues must first be investigated and determined to be adequate, unobstructed, and with no upper-story openings or connections. All applicable clearances, air for combustion and ventilation requirements shall be observed.
- 9.11.3 Approved factory-built fireplaces, where installed indoors, must be vented through an approved Type B vent or lined chimney. All applicable clearances, air for combustion and ventilation requirements shall be observed.

#### 9.12 ILLUMINATING DEVICES

- 9.12.1 All gas lights shall be listed by the **IAS, CSA, UL** or other qualified technical listing organization. Gas lights shall be installed according to their listings, all local codes, National Grid requirements and the manufacturer's installation instructions.
- 9.12.2 Gas pressure regulators shall be installed for all illuminating appliances.
- 9.12.3 Gas lamps designed for post mounting shall be securely and rigidly attached to a post.
- 9.12.4 Adequate concrete shall be used around the base of the supporting lamp post and underground piping shall not be embedded in post concrete.
- 9.12.5 A shutoff valve shall be installed on the line to the gas light at the point where it connects to the house riser and shall be in an accessible location.
- 9.12.6 Where permitted by local authorities having jurisdiction, outdoor gas torches, used to symbolize some event or to adorn landmarks, entrances, etc., may be installed. These devices often require high gas inputs, and therefore, the contractor/customer shall proceed with caution. National Grid shall be consulted on all such installations.
- 9.12.7 New pedestals for gas torches shall be supported by an adequate concrete base. Gas pipe shall not be embedded in this base. Existing columns, which are used to support gas torches, may encase inlet gas piping subject to approval of the manner of connection by National Grid.

9.12.8 No gas torch flame shall be less than 7' above the immediate ground level.

### 9.13 NATURAL GAS COMBUSTION ENGINES

Natural gas-fired combustion engines are generally utilized for engine-driven air conditioning, cogeneration, heat pump, generators and other gas engine driven applications. National Grid is to be consulted regarding any proposed installations. All installations shall be performed according to the manufacturer's installation instructions, New York State and City Codes and NFPA-37. National Grid shall be consulted prior to proceeding with any plans to install natural gas combustion engines.

### 9.14 COMPRESSED NATURAL GAS (CNG,) STATIONS

Compressed Natural Gas (CNG) stations shall not be planned without consultation with National Grid.

### 9.15 UNVENTED ROOM HEATERS

Unvented room heaters shall be tested in accordance with ANSI Z21.11.2 and shall be installed in accordance with NFPA 54, FGCNYS, NYCFGC and the manufacturer's installation instructions. They may not be used as the primary heat source. Unvented room heaters must be equipped with an oxygen depletion sensor safety shutoff system. Unvented room heaters are currently prohibited in New York City.

### 9.16 OTHER EQUIPMENT

Any gas utilization equipment not covered in this manual shall be installed according to the National Fuel Gas Code, FGCNYS, NYCFGC **and local codes**. National Grid shall be consulted for further guidance on any equipment not covered in this book.

### 9.17 COMBO WATER HEATERS

Water heaters utilized both to supply potable hot water and provide hot water for space heating applications shall be listed and labeled for such applications by the manufacturer and shall be installed in accordance with the manufacturers installation instructions (in New York City installed in accordance with the New York City Plumbing.



# APPENDIX A

**APPENDIX A****SERVICE REGULATOR VENT PIPING REQUIREMENTS**

*NOTE: If any portion of the regulator vent line is concealed or otherwise inaccessible, National Grid is required to perform a vent line continuity test to verify the vent line is continuous and unobstructed from the regulator vent port to the point of discharge, where it exits the building. Customers, building owners, etc. shall be responsible to provide safe access to the vent terminus (e.g., safe inside access to a rooftop, etc.).*

- 1.0 Contractors shall size and lay out service regulator vent piping in accordance with the following requirements:
  - 1.1 Vent lines for gas pressure service regulators shall be piped using rigid steel Schedule 40 pipe, sized in accordance with Tables 2 through 7 of this Appendix, and installed in accordance with the National Grid Construction Standard 020013-CS and the instructions contained in this Appendix. All service regulator vent lines shall be located such that, should venting to the atmosphere occur, a hazard is not created.
  - 1.2 Vent piping installed outdoors shall be galvanized or primed and painted with screwed ends. For those cases where vent pipe is installed with welded end connections, the pipe shall be primed and coated with a painting system suitable for outdoor applications. Vent piping installed through outside walls shall be protected against corrosion in accordance with the requirements contained in Section 8.0 of this book.
  - 1.3 Where there is more than one service regulator or relief valve at a meter header location, each regulator shall have its own separate vent line to the outdoors. Manifolding of vent lines shall not be permitted.
  - 1.4 Regulators shall not be vented commonly with external relief valves or devices requiring atmospheric air pressure to balance a diaphragm.
  - 1.5 National Grid Technical Lead will provide size and termination location, as part of the installation design when vent lines are required. The contractor shall furnish the labor, materials and the layout for the installation of the regulator vent line.
  - 1.6 The size of service regulator vent lines shall not be less than the size of the connection on the regulator vent.
  - 1.7 All vent lines shall have an insulating union installed as close to the regulator as possible. The insulating union will be provided by National Grid.
  - 1.8 Vent line termination points shall be provided with approved rain caps and insect-resistant screens. National Grid shall furnish the contractor with these combination rain caps and insect-resistant screen devices at the construction site meeting with the installing contractor. The contractor shall provide the labor to install the devices. Combination vent caps are available for the following pipe sizes as shown in Table 1.

TABLE 1

**NATIONAL GRID COMBINATION VENT CAPS**

NATIONAL GRID ITEM ID	VENT PIPE DIAMETER
301023	3/4"
786214	1"
301026	1-1/4"
301035	2"
301036	3"
301037	4"

- 1.9 Vent line piping shall contain a minimum number of bends and elbows. Each fitting offers resistance to gas flow, that can be expressed as an **equivalent length** of pipe. Equivalent lengths for elbows are given underneath each table in Tables 2 through 7 of this Appendix. The equivalent length of the fittings shall be **added to the actual length of piping** when selecting vent pipe size.
- 1.10 Where vent pipe size in the tables is larger than the regulator vent outlet, a pipe reducer (increaser) shall be installed as close to the regulator vent as possible, preferably immediately at the regulator vent outlet.
- 1.11 Vent piping is not permitted to be installed below-grade. If it penetrates a building foundation wall above ground, the piping shall meet the same requirements as buried gas piping regarding corrosion protection, i.e., coating, wrapping, cathodic protection, etc. in accordance with the Section 8.0 of this book.
- 1.12 Regulator vent piping for outdoor regulators shall only be required to clear a building overhang or to provide the required clearances above the ground, or away from building openings or windows. Clearance for a given installation shall be as specified in the National Grid construction standards.
- 1.13 For Tables 2 through 7 which follow, the maximum length of vent pipe and number of fittings allowed in each case **shall not be exceeded under any circumstances.**

**RECOMMENDED VENT LINE SIZING CHARTS**

If length exceed the lengths on the chart, contact National Grid's technical lead.

**TABLE 2**

For regulators with 3/4" screwed end connections and 3/4" regulator vent opening, that reduce pressure in mains operating at pressures between 99 psi and 124 psi.

<b>3/4" Regulator Vent Pipe</b>			
Max. Length	12'	10'	8'
Number of 90° Elbows *	1	2	3

\* Each elbow equivalent length = 2.0'

**TABLE 3**

For regulators with 3/4" x 3/4" or 3/4" x 1" screwed end connections and 3/4" or 1" regulator vent opening, that reduce pressure in mains operating at pressures between 99 psi and 124 psi.

<b>1 1/4" Regulator Vent Pipe</b>			
Max. Length	20'	17'	13'
Number of 90° Elbows *	1	2	3

\* Each elbow equivalent length = 3.5'

**GAS SERVICE REGULATOR VENT SIZING CHARTS****TABLE 4**

For regulators with 3/4" x 3/4" or 3/4" x 1" screwed end connections and 3/4" or 1" regulator vent opening, that reduce pressure in mains operating at pressures between 99 psi and 124 psi.

<b>1" Regulator Vent Pipe</b>			
Max. Length	15'	12'	10'
Number of 90° Elbows *	1	2	3

\* Each elbow equivalent length = 2.6'

**TABLE 5**

For regulators with 3/4" screwed end connections and 3/4" regulator vent opening, that reduce pressure in mains operating at pressures of 60 psi or less.

<b>3/4" Regulator Vent Pipe</b>			
Max. Length	29'	27'	25'
Number of 90° Elbows *	1	2	3

\* Each elbow equivalent length = 2.0'

**GAS SERVICE REGULATOR VENT SIZING CHARTS**

**TABLE 6**

For regulators with 1 1/4" body size and 3/4" regulator vent opening, that reduce pressure in mains operating at pressures of 60 psi or less.

<b>1 1/4" Regulator Vent Pipe</b>	<b>2" Regulator Vent Pipe</b>
Maximum Length = 43'	Maximum Length = 60'
Number of Elbows* = 3	Number of Elbows* = 3

\* Each elbow equivalent length = 3.5'

***NOTE***

*1-1/4" Regulators with 1-1/4" bodies and 3/4" vent openings shall have 1-1/4" size vent lines as a minimum*

**TABLE 7**

For regulators with 2" body size 1" regulator vent opening that reduce pressure in mains operating at pressures between 60 psi and 124psi.

<b>2" Regulator Vent Pipe</b>
Maximum Length = 23'
Number of Elbows = 1

\* Each elbow equivalent length = 5.2'

# APPENDIX B

## APPENDIX B

### CHOOSING A FURNACE OR BOILER

#### Higher Efficiency. Its Advantages and Disadvantages

Since the energy crisis of the 1970's consumers have been motivated to demand higher efficiency furnaces and boilers, and to increase the thermal insulation and tightness of their homes. As a result, manufacturers have responded with the higher efficiency heating units which are widely in use today, and builders have responded with the increase in tighter construction methods for homes now equally widely used. As a result of these new trends, a significant amount of attention has been focused on certain technical topics in the heating business which have traditionally been accepted as cut and dried, but recently have caused some controversy. It was discovered, to the dismay of many, that these long-accepted ways of installing heating appliances are no longer valid. The changes faced by today's furnace and boiler installers include increased efficiency, reduced dilution air, increased air contamination and decreased heating loads. It has been common to discover that new installations are deficient because of improper combustion, dilution and ventilation air, and even improperly selected boiler or furnace sizes. Therefore, the following information is provided to help ensure that new installations and conversions are properly designed and installed. The correct place to begin is for to selecting a furnace or boiler for your installation.

#### Increased Thermal Efficiency Proper Venting

Increased thermal efficiency of newer units means, among other things, that for a given retrofit installation in a building that has not been modified using insulation and/or caulking, a smaller capacity unit will often do the same job as the older unit did. But it is possible that the older unit may not have been sized correctly! Indeed, many older units were oversized. Therefore, it can be problematic to simply substitute a new unit of the same input as the older one., Increased efficiency of abeating unit typically means a lower flue gas temperature, since most higher efficiency units wring out more Btu's from the flue gases in their heat exchangers. This lower outlet temperature means that the flue gases start their trip out the vent much closer to their dewpoint. Thus, condensate will be produced in the vent earlier in the on-cycle, and more condensate per total unit volume of flue gases will be produced in the new units than in the older, less efficient units. This means that the "wet time" in the vent will be longer, during which time the condensate stays in the stack without being vaporized by flue gases.

Since many Category I, mid-efficiency units are fan-assisted, the draft hood is eliminated, thereby essentially eliminating dilution air to the vent, reducing the total vent flow. Combining this characteristic with the use of vent dampers, off cycle loss of gases through the vent is reduced drastically. As a result, no dilution air can be relied on during the off cycle to help dry the stack. In addition, these characteristics combine to leave a vent pipe even colder during the off-cycle than in older less efficient units, requiring a longer time to heat up during the on-cycle.



In summary, comparing a newer, more efficient unit to an older less efficient unit of the same input, a smaller volume of flue gases will flow in the new unit at a lower temperature through a colder vent, which must be relied upon to remove essentially the same amount of water vapor as was produced in the old unit. The capacity of these gases to vaporize the moisture is significantly less in the new unit as compared to the old. The result is longer wet time in the new unit's vent, a condition which promotes corrosion very quickly, especially if chlorine from indoor air condition is absorbed into the condensate, producing hydrochloric acid. A corroded vent can release deadly carbon monoxide into the living space. An equally deadly scenario is the deterioration that takes place in a masonry chimney, where the mortar disintegrates, the lining collapses, and the chimney becomes blocked, also spilling flue gases into the living space.

**Special care must be taken when replacing older heating equipment that will be vented into an existing exterior masonry chimney. Please follow the Venting tables listed in NFPA-54 or the FGCNYS.**

#### Tighter Buildings: Combustion Air

If the building has been upgraded with new insulation, thermal-pane and tightly sealed windows, along with caulking and wrapping, the thermal characteristics of the building have been altered to make it more thermally efficient. The increased thermal efficiency of a building means the heating load is lower. The tightness of the building means the infiltration losses have been decreased, but the combustion air requirements, which formerly depended on a certain amount of infiltration, must be closely re-examined. If infiltration, and therefore some of the source of combustion air, has been drastically reduced, the reduction can increase spillage of combustion products upon start-up of a draft hood appliance. Secondly, the lowered rate of air change means that any source of combustion air contamination, such as chlorides from hairsprays, etc. will remain at an elevated concentration rather than be diluted. Contaminants containing chlorine have been shown to greatly increase the corrosivity of flue gas condensate, forming hydrochloric acid.

All of these characteristics taken together require that a vent be sized as carefully as possible, with special attention not to over-size the vent. In the past, gas furnaces and boilers released more than 25 % of their input energy into their vents. This generous amount of heat flowing through the vent made vents much more forgiving of design errors. Now, proper venting of higher efficiency furnaces and boilers requires more knowledge and greater care on the part of the installer.

### A Case of Improper Venting

Clearly, a great deal of attention must be paid to venting of modern boilers/furnaces. Take as an example, a typical situation where a person installs a new boiler to replace an aging, less efficient one. In assessing the situation, it is determined that a newer, Category I, mid efficiency, fan assisted unit is a sound, economical choice. It seems logical that a unit of the same input rating should be selected. A contractor is hired, and installs most things properly, but vents the unit to the same outside chimney used for the older unit. After a period of time, the consumer calls National Grid Energy Delivery to trouble-shoot a "leak" in his newly installed boiler. He is dismayed to discover that there is no real leak, but that his chimney is condensing. He decides that this is not a real problem, and that there is no need for further action. Soon his chimney tiles begin to collapse inside, and begin to block the vent gases to the point where the unit shuts down on high pressure. Now he has a very large repair bill on his hands to rectify his collapsed chimney. All of this could have been prevented by selecting the correct venting arrangement. In this case, an approved, listed chimney liner system, properly sized and installed, would have saved a large sum of money and many headaches.

### Pre-Sale Inspection

The heating contractor seeking to sell a furnace should begin approaching a job by first carefully assessing the heating load of the structure, the suitability of the existing system vent, and the environment into which the unit will be placed. It is also important that sales and installation personnel understand the venting characteristics of the different types of appliances available on the market, as well as the differences in combustion, dilution and ventilation air requirements of the newer, higher efficiency units. Computer heat loss programs exist in the market today that make this tedious task less demanding.

### **Special care must be taken when replacing older heating equipment that will be vented into an existing exterior masonry chimney**

Retrofit furnaces or boilers should not be recommended to the consumer on the basis of rules-of-thumb regarding the heat load, nor should it be assumed that the existing venting system can be used without modification. It is imperative that the selection and sales process include a pre-sale inspection of the existing furnace or boiler, the venting system, and the building. It is important to recognize that every furnace or boiler is not equally well suited to every installation. The inspection will help the seller to accurately determine which furnace or boiler can be recommended to the consumer, and will avoid problems for all parties involved.

### CO ALARMS

In New York City, Local Law 7, requires the installation of CO (carbon monoxide) Alarms in all new and existing 1 and 2 family houses, apartment buildings, hotels dormitories, nursing homes and schools, where fossil fuel burning furnaces or boilers are installed.

In New York State, Part 1225.2 of Title 19, requires the installation of CO Alarms in newly constructed dwelling units and in dwellings units offered for sale.

Revision 10, June 2015

The heating contractor should be familiar with the NYC and NYS CO Alarm Law and should determine if a working CO Alarm is installed at the location and should discuss the CO Alarm Laws with the customer.

For full text of the NYC and NYS CO Alarm Law, see appendix G

Please note: National Grid recommends the installation of CO Alarms in all areas and recommends annual maintenance of the heating system.

# APPENDIX C

**APPENDIX C**  
**NATIONAL GRID**  
**NEW METER SET HOTLINE**

NATIONAL GRID  
Long Island/Rockaway Peninsula  
1-877-597-0426\*  
175 E. Old Country Road  
Hicksville, N.Y. 11801

\* For non project managed jobs. For projected managed jobs the responsible project manager should be contacted.

New York City Call Center  
Metrotech  
Brooklyn  
1-718-643-4050\*



The power of action.™

## ***Ensuring a Successful Gas Meter Set***



- ✓ Gas Meter Header has been kept plumb and square
- ✓ Final grade has a minimum clearance of 6” to the bottom of the meter
- ✓ Gas regulator vent maintains 18” minimum height from grade
- ✓ Gas regulator vent meets 18” clearance requirements from windows, doors, other openings into the building
- ✓ Gas regulator vent maintains a minimum of 10’ from any mechanical air intakes
- ✓ Gas regulator vent terminus maintains 3’ from any source of ignition
- ✓ Gas regulator vent and meter header maintains a minimum of 12” horizontally from any electric meter pans or electric meters
- ✓ Electric meters meet clearance requirements and are not installed directly above the gas regulator or meter header
- ✓ Electric meter has been installed and the dwelling is powered up
- ✓ Customer owned piping has been sleeved or properly cold wrapped for protection if going through a masonry wall
- ✓ Multiple meter header has been properly secured to the wall
- ✓ Multiple meter headers have had ID tags installed identifying the units locations
- ✓ Protection posts shall be installed to code if required to prevent vehicular damage
- ✓ Make up air requirements meet combustion needs
- ✓ If underground customer owned piping is used the *Customer Owned Piping Certificate* has been filled out with sketch completed and left on the jobsite in “Long Island / NYC”
- ✓ City, State, Town, Village or National Grid pressure test affidavit has been left on site
- ✓ In NYC “BIS” number has been established with NYC building department
- ✓ All customer owned piping is installed to National Grids Blue Book requirements and meets City, State, Local, IFGC and / or NFPA Fuel Codes  
*Check with the authority having jurisdiction to verify which code they are following*
- ✓ National Grid has access to the dwelling to install meter and fire one piece of equipment to obtain Lock Up and Running Pressures

# APPENDIX D

**APPENDIX D****GAS PIPING SYSTEM PRESSURE TESTING REQUIREMENTS  
AND INSTRUCTIONS****1.0 PURPOSE**

- 1.1 This Appendix provides information and instructions for the contractor regarding National Grid requirements for pressure testing a gas piping system.

**2.0 SCOPE**

- 2.1 This document provides information concerning the following: 1. When a pressure test is required to be witnessed by National Grid; 2. The test pressure and test duration (time interval) shall be used for the test; 3. What equipment and/or instrumentation is required for the test; 4. How to conduct the test; and 5. How to report the test results.

**3.0 DEFINITIONS**

- 3.1 ***Dial Check:*** A test in which a piping system is proven to be free of leaks that can only be administered after the meter has been installed. The test is conducted by checking movement of that dial on the gas meter that registers the smallest amount of gas. The slightest movement of that dial shall be construed to mean that a leak is present in the system.
- 3.2 ***Leak Test:*** A test in which a piping system is proven to be free of leaks by **pressurizing the system with natural gas** to its operating pressure and applying a leak-test solution, such as a solution of soap suds, to all the joints in the system.
- 3.3 ***Pressure Test:*** A test in which a piping system is proven to be free of leaks and capable of operating safely by:
- a. Isolating the system from its normal connections. This shall be accomplished by disconnecting the system from its gas source and capping or plugging the disconnected ends.
  - b. Raising the internal pressure of the gas piping system (usually a multiple of its normal operating pressure) for a specified period of time (time duration or time interval) using air or an inert gas.
  - c. Monitoring its pressure over the specified period of time to assure that the pressure does not decrease over that time.
- 3.4 **Minor Alterations; Minor Installation:** An installation in which additional piping is added to an existing piping system already connected to a gas meter. Examples are:
- a. Relocation of a gas meter;
  - b. Addition or replacement of a gas appliance.



#### 4.0 **GENERAL**

- 4.1 The owner, contractor shall first determine if a local jurisdictional pressure test is required.

It is the **contractor's responsibility** to determine whether or not the need exists in the geographical area of the installation for a gas piping system pressure test and what the specific test requirements are for a given authority having jurisdiction.

- 4.2 For Long Island installations, the licensed plumber is required to self certify the installation's integrity by completing the form in Appendix E (This self certification form only applies to Towns without plumbing inspectors). This completed form, along with diagram of any buried piping, will be required at the site prior to the installation of the gas meter by National Grid personnel. It is the Contractor responsibility to install customer owned piping to all National Grid's requirements and to Federal, State and local Codes. Failure to comply with these Codes, may delay the gassing in on the installation. For commercial installations with Class 800 meters and larger, National Grid **may** witness the pressure test in those town without plumbing inspectors.

#### 5.0 **GAS DISTRIBUTION PIPING (AFTER THE GAS METER)**

- 5.1 All installations and testing of gas piping shall conform to the applicable code e.g., NYC Administrative Code, NFPA-54, FGCNY, NYCFGC, State Codes, Local Codes). **Note: All Customer Owned piping in NYC shall be steel.**
- 5.2 Piping with a maximum operating pressure up to and including ½ psig (14" w.c.).
- A. Pipe sizes over 4" are to butt welded.
  - B. Completed line is to be tested with air or inert gas at 3psig for a minimum of 30 minutes.

#### **FOR NEW YORK CITY**

- 5.3.1 Piping with a maximum operating pressure above ½ psig (14" w.c.) up to and including 3 psig.
- A. Pipe sizes 4" and over are to butt welded.
  - B. Completed line is to be tested with air or inert gas at 50 psig for a minimum of 30 minutes.

#### **FOR LONG ISLAND**

- 5.3.2 Piping with a maximum operating pressure above ½ psig (14" w.c.) up to and including 5 psig.
- A. Pipe sizes **over** 4" are to butt welded.
  - C. Completed line is to be tested with air or inert gas at 50 psig for a minimum of 30 minutes.

**FOR NEW YORK CITY**

5.4.1 Piping with a maximum operating pressure above 3 psig and up to but excluding 125 psig.

- A. All piping is to be butt-welded and radiographed.
- B. Testing
  - 1. For piping with a maximum operating pressure of 3 to 15 psig, the completed line is to be tested at 100 psig for a minimum of 1 hour.
  - 2. For piping with a maximum operating pressure above 15 psig, the completed line is to be tested to twice the maximum allowable operating pressure, but not less than 100 psig, for a minimum of 1 hour.
  - 3. Fresh water may be used as the test medium only when the required test pressure exceeds 100 psig.

**FOR LONG ISLAND**

5.4.2 Piping with a maximum operating pressure above 5 psig and up to but excluding 125 psig.

- A. All piping is to be butt-welded.
- B. Testing
  - 1. For piping with a maximum operating pressure of 5 to 15 psig, the completed line is to be tested at 100 psig for a minimum of 1 hour.
  - 2. For piping with a maximum operating pressure above 15 psig, the completed line is to be tested to twice the maximum allowable operating pressure, but not less than 100 psig, for a minimum of 1 hour.
  - 3. Fresh water may be used as the test medium only when the required test pressure exceeds 100 psig.

**FOR LONG ISLAND AND NEW YORK**

5.5 For piping with a maximum operating pressure of 125 psig or greater, contact National Grid's Engineering Area for welding and pressure test requirements.

5.6 Testing material and all anchoring and support of pipe shall satisfy applicable minimum National Grid requirements. Plastic pipe, tubing and fittings shall not be used. For information, consult the appropriate National Grid Sales, Support, & Solutions Area or a Project Manager.

5.7 For Buried Plastic or Above Ground Concealed Piping:

- A. All buried plastic, galvanized steel or concealed piping that is above ground, must be installed and tested per National Grid requirements as stated in Section 8.6.4. All completed work must include

inspection criteria (ie. caution tape, anodes) prior to backfilling or closing in of the piping.

- B. All steel pipe, regardless of being buried or above ground, that is painted, coated or wrapped shall be pressure tested at a minimum of 90 psig for the following times:

Less than 2” diameter; - 1 hour

2” – 12” diameter - 4 hours

**(Note: Only painted or galvanized pipe is permitted above grade)**

- C. Screwed fittings shall not be used in concrete.  
Steel piping for incidental outside use, where installed in the ground or in concrete, shall be coated to prevent corrosion. All piping installed in the ground shall comply with applicable sections of National Grid specifications for underground pipe.

5.8 Pressure Test Requirements Summary

**PRESSURE TEST REQUIREMENTS**

OPERATING PRESSURE (FOR PLASTIC /GALVANIZED OR BARE STEEL PIPE	TEST PRESSURE AND DURATION	
	NEW YORK Per N.Y.C. Building Code sect. 403.1 and 406.4	LONG ISLAND See note 1
LP to 14” W.C.	3 PSIG / 30 MINUTES	3 PSIG / 30 MINUTES
> 14” W.C. - 3 PSIG	50 PSIG / 30 MINUTES	-----
> 14” W.C. - 5 PSIG	-----	50 PSIG / 30 MINUTES
> 3 PSIG – 15 PSIG	100 PSIG / 1 HOUR	
> 5 PSIG – 15 PSIG	-----	100 PSIG / 1 HOUR
>15 PSIG – 125 PSIG	2X MAOP, BUT NOT LESS THAN 100 PSIG / 1 HOUR	2X MAOP, BUT NOT LESS THAN 100 PSIG / 1 HOUR

Note 1: In Long Island, the test duration in the above chart is for 500 cubic feet of pipe being tested. For volumes > 500 cubic feet, add an additional ½ hour to the pressure test for every additional 500 cubic feet of pipe being tested. The duration of the test shall not be required to exceed 24 hours (NFPA-54)

OPERATING PRESSURE ANY STEEL PIPE THAT IS PAINTED, COATED OR WRAPPED (ABOVE GROUND OR BELOW GROUND)	TEST PRESSURE AND DURATION	
	NEW YORK	LONG ISLAND
LP – 60 PSIG	90 PSIG LESS THAN 2” DIA. – 1 HOUR 2”-12” DIAMETER – 4 HOURS	90 PSIG LESS THAN 2” DIA. – 1 HOUR 2”-12” DIAMETER – 4 HOURS

## 6.0 **INSTRUCTIONS**

- 6.1 The gas meter, relief valve, service regulator and appliance gas train components and manual shut-off valves shall be physically disconnected from the gas supply system for the pressure test of the customer-owned gas piping system.

When a local town/municipality requires the test, the form for recording the test results will vary depending on the local government. If contractors require a copy, the contractor shall make arrangements through the local governmental jurisdictional office. If copies of pressure test certificates are desired, the necessary arrangements to obtain copies shall be made by the contractor. National Grid requires a copy of the certificate before the activation of gas.

# APPENDIX E

June, 2015

**RE: Customer Owner Gas Piping Inspection Certificate**

Attached is the new **Customer Owner Gas Piping Inspection Certificate** form which is to be used in the Long Island territories whenever buried gas piping is installed downstream of the gas meter. This form cannot be substituted in lieu of the inspection certificate issued by the jurisdictional town inspector. However, in those jurisdictions where third party town inspections are not being performed, the licensed plumber is required to self certify the installation integrity by completing this form. This form will be required at the site prior to the installation of the gas meter by National Grid personnel.

Additional copies of this form can be obtained on-line.

If there are any questions pertaining to the information requested on the form, please do not hesitate to contact your National Grid representative.



This document **MUST** be completed and signed by the Installer prior to your natural gas service being turned on by National Grid. We appreciate your cooperation.

**CUSTOMER OWNED GAS PIPING INSPECTION CERTIFICATE**

The undersigned installation contractor hereby represents and warrants that all gas piping and related appliances, appurtenances and equipment installed at the premises described herein have been installed in accordance with all applicable codes, regulations and standards in effect as of the date of this Certificate including, but not limited to, the **Fuel Gas Code of New York State**, the **National Fuel Gas Code**, the **National Grid Blue Book** and the original equipment manufacturer's specifications, guidelines and installation instructions.

The undersigned installation contractor further represents and warrants that all gas piping installed at the premises described herein has been subjected to and passed the pressure test requirements as outlined in the **Fuel Gas Code of New York State** and **National Grid Specifications and Requirements for Gas Installations** as written in the Blue Book. The installation contractor MUST include a historical sketch of the underground piping location as required per the Blue Book, Section 8.4 with this Certificate

The undersigned installation contractor acknowledge that **National Grid's** relying upon the installation contractor's representation and warranties, as well as the accuracy of the information contained in this Certificate, as a condition to turning on the natural gas services at the premises described herein.

Customer Name \_\_\_\_\_  
 (Please Print)

Service Location \_\_\_\_\_  
 (Street - City)

Daytime Phone \_\_\_\_\_ Evening Phone \_\_\_\_\_ Cell Phone \_\_\_\_\_

Contractor Name \_\_\_\_\_  
 (Please Print) (Authorized Signature)

Business Location \_\_\_\_\_  
 (Street - City)

Daytime Phone \_\_\_\_\_ Cell Phone \_\_\_\_\_ License # \_\_\_\_\_

Pressure Test @ \_\_\_\_\_ P.S.I. Duration Time \_\_\_\_\_ (Hrs/Min) Historical Sketch Provided? Y \_\_\_\_\_ N \_\_\_\_\_  
 (**Refer to Blue Book for Test Pressures Required and Time Durations**)  
 Local Municipality/Town Pressure Test Certificate Provided? Y \_\_\_\_\_ N \_\_\_\_\_ Plumbing Permit # \_\_\_\_\_  
 Piping being tested? Header Y \_\_\_\_\_ N \_\_\_\_\_ Houeline Y \_\_\_\_\_ N \_\_\_\_\_ CSST Piping Bonded and Grounded Y \_\_\_\_\_ N \_\_\_\_\_

**Equipment / Appliances Installed -**

Generator Y \_\_\_\_\_ N \_\_\_\_\_ Pool Heater Y \_\_\_\_\_ N \_\_\_\_\_ House Heat Y \_\_\_\_\_ N \_\_\_\_\_  
 Barbeques Y \_\_\_\_\_ N \_\_\_\_\_ Water Heater Y \_\_\_\_\_ N \_\_\_\_\_ Meter Header Y \_\_\_\_\_ N \_\_\_\_\_  
 Commercial Appliances Y \_\_\_\_\_ N \_\_\_\_\_ How Many? \_\_\_\_\_ Other (Specify) \_\_\_\_\_

Installing contractors, **MUST** check and complete the following information for all **Customer Owned Underground Gas Piping** that has been installed at the subject premises in accordance with this Certificate. Please include the name of the pipe manufacturer, lot number of the pipe installed and the size of the pipe installed.

Installed Pipe Size \_\_\_\_\_ Pipe Installed @ Minimum Depth of 18"? Y \_\_\_\_\_ N \_\_\_\_\_

**Plastic** - Pipe Manufacturer \_\_\_\_\_ Lot Number \_\_\_\_\_ SDR \_\_\_\_\_  
 Mechanical Fittings Used? Y \_\_\_\_\_ N \_\_\_\_\_ Plastic Fussions? Y \_\_\_\_\_ N \_\_\_\_\_ # Made \_\_\_\_\_  
 Tracer Wire Installed? Y \_\_\_\_\_ N \_\_\_\_\_ Metallic Caution Tape? Y \_\_\_\_\_ N \_\_\_\_\_  
 Non-Metallic Caution Tape? Y \_\_\_\_\_ N \_\_\_\_\_

**Coated Steel** - Anode(s) - Number/Weight \_\_\_\_\_ Cadweld Y \_\_\_\_\_ N \_\_\_\_\_

**National Grid Use Only**

Technician/ Responder \_\_\_\_\_ Meter Number \_\_\_\_\_  
 (Employee Name / Number)

Turned On \_\_\_\_\_ Grid # \_\_\_\_\_ Residential \_\_\_\_\_ Non-Residential \_\_\_\_\_  
 (Date)

# APPENDIX F



## **Corrugated Stainless Steel Tubing (CSST)**

**At its meeting held on September 10, 2008, the State Fire Prevention and Building Code Council determined that adopting this rule on an emergency basis is necessary to preserve public safety by clarifying requirements for electrical bonding of gas piping, clarifying requirements for protection of gas piping against physical damage, and adding new requirements for installation of gas piping made of corrugated stainless steel tubing (CSST), which will increase protection against fires caused by lightning strikes in the vicinity of buildings equipped with CSST gas piping and fires caused by accidental punctures of CSST gas piping.**

**EFFECTIVE September 25, 2008**

**Subdivision (d) of section 1220.1 of title 19 NYCRR is amended by adding new paragraphs (9), (10), (11), and (12) to read as follows:**

**(9) 2007 RCNYS Section G2411.1. For the purposes of applying the 2007 RCNYS in this State, the text of Section G2411.1 in Chapter 24 of the 2007 RCNYS shall be deemed to be amended and restated in its entirety to read as follows:**

**“G2411.1 (310.1) Gas pipe bonding - systems that contain no CSST. In the case of a gas piping system that contains no corrugated stainless steel tubing (CSST), each above-ground portion of the gas piping system that is likely to become energized shall be electrically continuous and bonded to an effective ground-fault current path. Gas piping shall be considered to be likely to become energized if any gas utilization equipment is connected to any portion of the gas piping system and to any electrical circuit(s). For the purposes of this Section G2411.1, gas piping shall be considered to be bonded to an effective ground-fault current path if such gas piping is connected to gas utilization equipment that is connected to the equipment grounding conductor of the circuit supplying that equipment. Nothing in this Section G2411.1 shall prohibit the bonding a gas piping system that contains no CSST in any manner described in Section E3509.7 of this code. (10) 2007 RCNYS Section G2411.2.”**

**(10) For the purposes of applying the 2007 RCNYS in this State, a new Section G2411.2 (to include sections G2411.2, G2411.2.1, G2411.2.2, and G2411.2.3) shall be deemed to be added to Chapter 24 of the 2007 RCNYS, immediately following Section G2411.1, said new Section G2411.2 to read as follows:**

**“G2411.2 (310.2) Gas pipe bonding - systems that contain CSST. A gas piping system that contains any corrugated stainless steel tubing (CSST) shall be electrically continuous and shall be bonded to the electrical service grounding electrode system at the point where the gas service enters the building or structure. No portion of the gas piping system shall be used as or considered to be a grounding**

electrode or a grounding electrode conductor. CSST shall be installed and bonded in accordance with this section G2411.2, and the stricter of: (a) the requirements set forth in the CSST manufacturer's installation instructions, or (b) the requirements set forth in Sections G2411.2.1, G2411.2.2, G2411.2.3, and G2415.5.

**“G2411.2.1 Bonding jumper. Where the electric service for the individual installation is 200 amperes or less, the bonding jumper shall not be smaller than 6 AWG copper wire or 4 AWG aluminum or copper-clad aluminum wire, and shall be permanently connected to the grounding electrode system. Where the electric service for the individual installation is more than 200 amperes, the bonding jumper size shall be determined in accordance with Table E 3503.1, and shall be permanently connected to the grounding electrode system.**

**“G2411.2.2 Bonding clamp. The bonding jumper shall be connected to the gas piping system with a bonding clamp that is listed for the material of the bonding jumper and for the material of the component of the gas piping system to which the bonding clamp is attached. The bonding clamp shall be attached to the gas piping system at a point which is inside the building or structure in which the gas piping is installed, on the downstream side of the gas meter or regulator, in an unconcealed and readily accessible space, and as close as practicable to the point where the gas service enters the building or structure. The bonding clamp shall be attached to a segment of metallic fuel gas pipe which (a) is a component of the gas piping system, (b) is electrically continuous with all CSST components of the gas piping system, (c) is made of steel or wrought-iron, (d) complies with Section G2414.4.2 of this code and with all other applicable provisions of Section G2414 of this code, and (e) is not less than 3 inches (76 mm) in length. Neither the CSST nor the brass hexagonal nut on the CSST fitting shall be used as an attachment point for the bonding clamp.**

**“G2411.2.3 Prohibited uses. CSST shall not be supported on or by other electrically conductive systems including copper water pipe, electric power cables, air conditioning and heating ducts, communication cables and structural steel beams. Electrical wiring, including the bonding jumper, shall be supported and secured independently of the CSST so that it does not come in contact with the CSST.”**

**(11) 2007 RCNYS Section G2415.5. For the purposes of applying the 2007 RCNYS in this State, the text of Section G2415.5 in Chapter 24 of the 2007 RCNYS shall be deemed to be amended and restated in its entirety, to include sections G2415.5 and G2415.5.1 and to read as follows:**

**“G2415.5 (404.5) Protection against physical damage. In concealed locations, where piping other than black or galvanized steel is installed through holes or notches in wood studs, joists, rafters or similar members less than 1.75 inches (44.45 mm) from the nearest edge of the member, the pipe shall be protected by shield plates. Such**

shield plates shall comply with the requirements of Section G2415.5.1, shall cover the area of the pipe where the member is notched or bored, and shall extend a minimum of 4 inches (102 mm) above sole plates, below top plates and to each side of a stud, joist or rafter. The movement of piping made of corrugated stainless steel tubing (CSST) shall not be otherwise constrained by straps, clips or other support devices. In addition, where CSST is installed in a concealed location and parallel to any stud, joist, rafter, or similar member, the CSST shall be protected by shield plates in any area where the CSST is not (a) physically supported in a manner that ensures the CSST will always be at least 1.75 inches (44.45 mm) away from the nearest edge of any member or (b) encased in a protective metal pipe made of schedule 40 steel or iron pipe or in a protective pipe sleeve made of a material approved by the code enforcement official as the equivalent of schedule 40 steel or iron pipe. Such shield plates shall comply with the requirements of Section G2415.5.1, shall cover the area the CSST is located, and shall extend a minimum of 4 inches (102 mm) to each side of the CSST.

**“G2415.5.1. Shield plates. In all cases, shield plates shall be certified or listed as complying with ANSI LC-1. In addition, in the case of piping made of CSST, shield plates shall be listed for use with the manufacturer’s CSST system.”**

**(12) 2007 RCNYS Section E3509.7. For the purposes of applying the 2007 RCNYS in this State, the text of Section E3509.7 in Chapter 35 of the 2007 RCNYS shall be deemed to be amended and restated in its entirety to read as follows:**

**“E3509.7 Bonding other metal piping. Where installed in or attached to a building or structure, metal piping systems likely to become energized shall be bonded to the service equipment enclosure, the grounded conductor at the service, the grounding electrode conductor where of sufficient size, or to the one or more grounding electrodes used. A piping system shall be considered to be likely to become energized if any equipment or appliance is connected to any portion of the piping system and to any electrical circuit(s). The bonding jumper shall be sized in accordance with Table E3808.12 using the rating of the circuit capable of energizing the piping. The equipment grounding conductor for the circuit that is capable of energizing the piping shall be permitted to serve as the bonding means. The points of attachment of the bonding jumper(s) shall be accessible.**

**“EXCEPTIONS:**

**“1. Interior metal water piping systems shall be bonded in accordance with Section E3509.6 of this code.**

**“2. Gas piping systems that contain no corrugated stainless steel tubing (CSST) shall be bonded in accordance with Section G2411.1 of this code.**

**“3. Gas piping systems that contain CSST shall be installed and bonded in accordance with Section G2411.2 of this code.”**

Subdivision (b) of section 1224.1 of title 19 NYCRR is amended to read as follows:

**(b) Referenced standards.** Certain published standards are denoted in the 2007 FGCNYS as incorporated by reference into 19 NYCRR Part 1222. Such standards are incorporated by reference into this Part 1224. Such standards are identified in the 2007 FGCNYS, and the names and addresses of the publishers of such standards from which copies of such standards may be obtained are specified in the 2007 FGCNYS. Such standards are available for public inspection and copying at the office of the New York State Department of State specified in subdivision (a) of this section. In addition, the 2005 edition of standard NFPA 70, entitled “National Electrical Code” (said standard being hereinafter referred to as NFPA 70-2005) shall be deemed to be one of the standards incorporated by reference into this Part 1224. The name and address of the publisher of NFPA 70-2005 from which copies of said standard may be obtained are:  
National Fire Protection Association  
Batterymarch Park  
Quincy, MA 02269.  
NFPA 70-2005 is available for public inspection and copying at the office of the New York State Department of State specified in subdivision (a) of this section.

Subdivision (c) of 1224.1 of Title 19 NYCRR is amended by adding new paragraphs (2), (3), and (4), to read as follows:

**(2) 2007 FGCNYS Section 310.1.** For the purposes of applying the 2007 FGCNYS in this State, Section 310.1 in Chapter 3 of the 2007 FGCNYS shall be deemed to be amended and restated in its entirety to read as follows:

**“310.1 Gas pipe bonding - systems that contain no CSST. In the case of a gas piping system that contains no corrugated stainless steel tubing (CSST), each above-ground portion of the gas piping system that is likely to become energized shall be electrically continuous and bonded to an effective ground-fault current path. Gas piping shall be considered to be likely to become energized if any gas utilization equipment is connected to any portion of the gas piping system and to any electrical circuit(s). For the purposes of this Section 310.1, gas piping shall be considered to be bonded to an effective ground-fault current path if such gas piping is connected to gas utilization equipment that is connected to the equipment grounding conductor of the circuit supplying that equipment. Nothing in this Section 310.1 shall prohibit the bonding a gas piping system that contains no CSST in any manner described in Section 250.104(B) of NFPA 70-2005.”**

**(3) 2007 FGCNYS Section 310.2.** For the purposes of applying the 2007 FGCNYS in this State, a new Section 310.2 (to include sections 310.2, 310.2.1, 310.2.2, and 310.2.3) shall be deemed to be added to Chapter 3 of the 2007 FGCNYS, immediately following Section 310.1, said new Section 310.2 to read as follows:

**“310.2 Gas pipe bonding - systems that contain CSST. A gas piping system that contains any corrugated stainless steel tubing (CSST) shall be electrically continuous and shall be bonded to the electrical service grounding electrode system at the point where the gas service enters the building or structure. No portion of the gas piping system shall be used as or considered to be a grounding electrode or a grounding electrode conductor. CSST shall be installed and bonded in accordance with this section 310.2, and the stricter of: (a) the requirements set forth in the CSST manufacturer’s installation instructions, or (b) the requirements set forth in Sections 310.2.1, 310.2.2, 310.2.3, and 404.5 of this code.**

**“310.2.1 Bonding jumper. Where the electric service for the individual installation is 200 amperes or less, the bonding jumper shall not be smaller than 6 AWG copper wire or 4 AWG aluminum or copper-clad aluminum wire, and shall be permanently connected to the grounding electrode system. Where the electric service for the individual installation is more than 200 amperes, the bonding jumper size shall be determined in accordance with Table 250.66 and Sections 250.66(A) through 250.66(C) of NFPA 70-2005, and shall be permanently connected to the grounding electrode system.**

**“310.2.2 Bonding clamp. The bonding jumper shall be connected to the gas piping system with a bonding clamp that is listed for the material of the bonding jumper and for the material of the component of the gas piping system to which the bonding clamp is attached. The bonding clamp shall be attached to the gas piping system at a point which is inside the building or structure in which the gas piping is installed, on the downstream side of the gas meter or regulator, in an unconcealed and readily accessible space, and as close as practicable to the point where the gas service enters the building or structure. The bonding clamp shall be attached to a segment of metallic fuel gas pipe which (a) is a component of the gas piping system, (b) is electrically continuous with all CSST components of the gas piping system, (c) is made of steel, wrought-iron, copper (if permitted by Section 403.4.3 of this code), or brass (if permitted by Section 403.4.3 of this code), or aluminum, (d) complies with the applicable provisions of Section 403.4 of this code and with all other applicable provisions of Section 403 of this code, and (e) is not less than 3 inches (76 mm) in length. Neither the CSST nor the brass hexagonal nut on the CSST fitting shall be used as an attachment point for the bonding clamp.**

**“310.2.3 Prohibited uses. CSST shall not be supported on or by other electrically conductive systems including copper water pipe, electric power cables, air conditioning and heating ducts, communication cables and structural steel beams. Electrical wiring, including the bonding conductor, shall be supported and secured independently of the CSST so that it does not come in contact with the CSST.”**

**(4) 2007 FGCNYS Section 404.5. For the purposes of applying the 2007 FGCNYS in this State, Section 404.5 in Chapter 4 of the 2007 FGCNYS shall be deemed to be amended and restated in its entirety, to include sections 404.5 and 404.5.1 and to read as follows:**

**“404.5 Protection against physical damage. In concealed locations, where piping other than black or galvanized steel is installed through holes or notches in wood studs, joists, rafters or similar members less than 1.75 inches (44.45 mm) from the nearest edge of the member, the pipe shall be protected by shield plates. Such shield plates shall comply with the requirements of Section 405.5.1, shall cover the area of the pipe where the member is notched or bored, and shall extend a minimum of 4 inches (102 mm) above sole plates, below top plates and to each side of a stud, joist or rafter. The movement of piping made of corrugated stainless steel tubing (CSST) shall not be otherwise constrained by straps, clips or other support devices. In addition, where CSST is installed in a concealed location and parallel to any stud, joist, rafter, or similar member, the CSST shall be protected by shield plates in any area where the CSST is not (a) physically supported in a manner that ensures the CSST will always be at least 1.75 inches (44.45 mm) away from the nearest edge of any member or (b) encased in a protective metal pipe made of schedule 40 steel or iron pipe or in a protective pipe sleeve made of a material approved by the code enforcement official as the equivalent of schedule 40 steel or iron pipe. Such shield plates shall comply with the requirements of Section 405.5.1, shall cover the area the CSST is located, and shall extend a minimum of 4 inches (102 mm) to each side of the CSST.**

**“405.5.1. Shield plates. In all cases, shield plates shall be certified or listed as complying with ANSI LC-1. In addition, in the case of piping made of CSST, shield plates shall be listed for use with the manufacturer’s CSST system.”**

---

**EFFECTIVE September 25, 2008**

# APPENDIX G

APPENDIX G

*New York State CO Alarm Law*

**Amanda's Law**

**Carbon monoxide alarm requirements to go into effect February 22, 2010**

As the result of legislation, Amanda's Law will go into effect February 22, 2010. It requires essentially all residences, both new and existing, to have carbon monoxide alarms installed. The specific requirements differ for new and existing residences and also on when the buildings were built and subcategories of occupancy groups. Existing one and two family residences will be required to have one carbon monoxide alarm installed on the lowest story having a sleeping area.

*Subdivision (d) of section 1220.1 in Part 1220 of Title 19 NYCRR is amended by adding a new paragraph (13) to read as follows:*

*(13) 2007 RCNYS section RR313.4. For the purposes of applying the 2007 RCNYS in this State, the text of section RR313.4 in chapter R3 of the 2007 RCNYS shall be deemed to be amended and restated in its entirety to read as follows:*

**“RR313.4 Carbon monoxide alarms.** This section covers the installation, performance and maintenance of carbon monoxide alarms and their components in new and existing buildings. The requirements of this section shall apply to all new and all existing buildings, without regard to the date of construction of the building and without regard to whether such building shall or shall not have been offered for sale.

**“Exception:** Compliance with this section is not required where no carbon monoxide source is located within or attached to the structure. However, compliance with this section is required if any carbon monoxide source is subsequently located within or attached to the structure.

*“For the purposes of this section RR313.4, the following terms will have the following meanings:*

**“The term ‘carbon monoxide source’** includes fuel fired appliances, equipment, devices and systems; solid fuel burning appliances, equipment, devices and systems; all other appliances, equipment, devices and systems that may emit carbon monoxide; fireplaces; garages; and all other motor vehicle-related occupancies.

**“The term ‘dwelling unit’** means a single unit providing complete, independent living facilities for one or more persons, including permanent provisions for living, sleeping, eating, cooking and sanitation.



“The term ‘**sleeping area**’ means a room or space in which people sleep.

“The term ‘**sleeping unit**’ means a room or space in which people sleep, which can also include permanent provisions for living, eating, and either sanitation or kitchen facilities but not both. Such rooms and spaces that are also part of a dwelling unit are not sleeping units.

“In the case of a building constructed on or after January 1, 2008, a carbon monoxide alarm shall be installed in each of the following locations:

“1. Within each dwelling unit or sleeping unit, on each story having a sleeping area.

“2. Within each dwelling unit or sleeping unit, on each story where a carbon monoxide source is located.

“One carbon monoxide alarm installed on a story of a dwelling unit or sleeping unit having both a sleeping area and a carbon monoxide source shall suffice for that story within that dwelling unit or sleeping unit.

“In the case of a building constructed before January 1, 2008, a carbon monoxide alarm shall be installed in each of the following locations:

“1. Within each dwelling unit or sleeping unit, on the lowest story having a sleeping area.

“When more than one carbon monoxide alarm is required to be installed within an individual dwelling unit, the alarms shall be interconnected in such a manner that the actuation of one alarm will activate all of the alarms in the individual unit. The alarm shall be clearly audible in all sleeping areas over background noise levels with all intervening doors close.

“**Exception:** Interconnection is not required where carbon monoxide alarms are permitted to be battery operated in accordance with section RR313.4.2.

“All carbon monoxide alarms shall be listed and labeled as complying with UL 2034 or CAN/CSA 6.19, and shall be installed in accordance with the manufacturer's installation instructions and this code.

“RR313.4.1 **Prohibited locations.** Carbon monoxide alarms shall not be located within or near the openings to garages, bathrooms or furnace rooms. Carbon monoxide alarms shall also not be located in or near locations specified as ‘prohibited,’ ‘not recommended’ or the like in the manufacturer’s installation instructions.

“RR313.4.2 **Power source.** The required carbon monoxide alarms shall receive their primary power from the building wiring when such wiring is served from a commercial source or an on-site electrical power system, and when primary power is interrupted,

shall receive power from a battery. Wiring shall be permanent and without a disconnecting switch other than those required for overcurrent protection.

**“Exception.** Carbon monoxide alarms shall be permitted to be battery operated when installed in buildings without commercial power or an on-site electrical power system or in buildings constructed before January 1, 2008.

**“RR313.4.3 Maintenance.** Carbon monoxide alarms shall be maintained in an operative condition at all times, shall be replaced or repaired where defective, and shall be replaced when they cease to operate as intended.

**“RR313.4.4 Disabling of alarms.** Carbon monoxide alarms shall not be removed or disabled, except for service or repair purposes.

**“RR313.4.5 One-family dwellings converted to bed and breakfast dwellings.** One-family dwellings converted to bed and breakfast dwellings shall have carbon monoxide alarms installed in accordance with the requirements of section F611 of the Fire Code of New York State.

**“RR313.4.6 Buildings under custody, licensure, supervision or jurisdiction of a department or agency of the State of New York.** A building which is under the custody, licensure, supervision or jurisdiction of a department or agency of the State of New York and which is regulated as a one-or two-family dwelling or multiple single-family dwelling (townhouse), in accordance with established laws or regulations of such department or agency, shall have carbon monoxide alarms installed in accordance with the stricter of the requirements of this section or the requirements of section F611 of the Fire Code of New York State.”

*Subdivision (d) of section 1225.1 in Part 1220 of Title 19 NYCRR is amended by adding a new paragraph (3) to read as follows:*

*(3) 2007 FCNYS section F611. For the purposes of applying the 2007 FCNYS in this State, the text of section F611 in chapter F6 of the 2007 FCNYS shall be deemed to be amended and restated in its entirety to read as follows:*

#### **“F611 CARBON MONOXIDE ALARMS**

**“F611.1 General.** This section covers the application, installation, performance and maintenance of carbon monoxide alarms and their components in new and existing buildings and structures. The requirements of this section shall apply to all new buildings and structures and to all existing buildings and structures, without regard to the date of construction of the building or structure and without regard to whether such building or structure shall or shall not have been offered for sale.

**“F611.1.1 Definitions.** For the purposes of this §F611, the following terms shall have the following meanings:

**“Carbon monoxide source.** The term ‘carbon monoxide source’ includes fuel fired appliances, equipment, devices and systems; solid fuel burning appliances, equipment, devices and systems; all other appliances, equipment, devices and systems that may emit carbon monoxide; fireplaces; garages; and all other motor vehicle-related occupancies.

**“Dwelling unit.** The term ‘dwelling unit’ means a single unit providing complete, independent living facilities for one or more persons, including permanent provisions for living, sleeping, eating, cooking and sanitation.

**“Existing buildings and structures.** The term ‘existing buildings and structures’ means buildings and structures constructed before January 1, 2008.

**“Multiple dwelling.** The term ‘multiple dwelling’ means a dwelling which is either rented, leased, let or hired out, to be occupied, or is occupied as the temporary or permanent residence or home of three or more families living independently of each other, including but not limited to the following: a tenement, flat house, maisonette apartment, apartment house, apartment hotel, tourist house, bachelor apartment, studio apartment, duplex apartment, kitchenette apartment, hotel, lodging house, rooming house, boarding house, boarding and nursery school, furnished room house, club, sorority house, fraternity house, college and school dormitory, convalescent, old age or nursing homes or residences, and a dwelling, two or more stories in height, and with five or more boarders, roomers or lodgers residing with any one family.

**“New buildings and structures.** The term ‘new buildings and structures’ means buildings and structures constructed after December 31, 2007.

“The term **‘sleeping area’** means a room or space in which people sleep.

“The term **‘sleeping unit’** means a room or space in which people sleep, which can also include permanent provisions for living, eating, and either sanitation or kitchen facilities but not both. Such rooms and spaces that are also part of a dwelling unit are not sleeping units.

**“F611.2 Equipment.** Carbon monoxide alarms shall be listed and labeled as complying with UL 2034 or CAN/CSA 6.19, and shall be installed in accordance with the manufacturer's installation instructions and this section.

**“F611.2.1 Combination smoke and carbon monoxide alarms.** Combination smoke and carbon monoxide alarms are permitted, provided the alarm is listed for such use. Combination smoke and carbon monoxide alarms shall have distinctly different alarm signals for smoke or carbon monoxide alarm activation.

**“F611.3 Where required.** Single and multiple station carbon monoxide alarms shall be provided in the locations described in this section.

**“Exception:** Compliance with this section is not required where no carbon monoxide source is located within or attached to the structure. However, compliance with

this section is required if any carbon monoxide source is subsequently located within or attached to the structure.

“F611.3.1 New buildings and structures: one-and two-family dwellings, multiple single-family dwellings (townhouses), and buildings owned as a condominium or cooperative and containing dwelling accommodations. A carbon monoxide alarm shall be installed in each of the following locations:

“1. Within each dwelling unit or sleeping unit, on each story having a sleeping area.

“2. Within each dwelling unit or sleeping unit, on each story where a carbon monoxide source is located.

“One carbon monoxide alarm installed on a story of a dwelling unit or sleeping unit having both a sleeping area and a carbon monoxide source shall suffice for that story within that dwelling unit or sleeping unit.

“F611.3.2 New buildings and structures: Group I-1 occupancies. A carbon monoxide alarm shall be installed in the each of following locations:

“1. On each story having a sleeping area.

“2. On each story where a carbon monoxide source is located.

“One carbon monoxide alarm installed on a story having both a sleeping area and a carbon monoxide source shall suffice for that story.

“F611.3.3 New buildings and structures: Group R occupancies not covered by section F611.3.1 or section F611.3.2, nursery schools (with sleeping units) not covered by section F611.3.1 or §F611.3.2, bed and breakfast uses not covered by section F611.3.1 or section F611.3.2, and multiple dwellings not covered by section F611.3.1 or section F611.3.2. A carbon monoxide alarm shall be installed in each of the following locations:

“1. In each dwelling unit or sleeping unit where a carbon monoxide source is located. In a multiple-story dwelling unit or sleeping unit, a carbon monoxide alarm shall be installed on each story having a sleeping area and on each story where a carbon monoxide source is located. One carbon monoxide alarm installed on a story having both a sleeping area and a carbon monoxide source shall suffice for that story.

“2. In each dwelling unit or sleeping unit that is on the same story as a carbon monoxide source.

“F611.3.4 Existing buildings and structures: one-and two-family dwellings, multiple single-family dwellings (townhouses), and buildings owned as a condominium or cooperative and containing dwelling accommodations. A carbon monoxide alarm shall be installed within each dwelling unit or sleeping unit on the lowest story having a sleeping area.

“F611.3.5 Existing buildings and structures: Group I-1 occupancies. A carbon monoxide alarms shall be installed on each story having a sleeping area.

“F611.3.6 Existing buildings and structures: Group R occupancies not covered by section F611.3.4 or section F611.3.5, nursery schools (with sleeping units) not covered by section F611.3.4 or section F611.3.5, bed and breakfast uses not covered by section F611.3.4 or section F611.3.5, and multiple dwellings not covered by section F611.3.4 or section F611.3.5. A carbon monoxide alarm shall be installed in each of the following locations:

“1. In each dwelling unit or sleeping unit where a carbon monoxide source is located. In a multiple-story dwelling unit or sleeping unit, a carbon monoxide alarm shall be installed on the lowest story having a sleeping area.

“2. In each dwelling unit or sleeping unit that is on the same story as a carbon monoxide source.

“F611.3.7 **Work completed** within one-and two-family dwellings, multiple single-family dwellings (townhouses), buildings owned as a condominium or cooperative and containing dwelling accommodations, Group R occupancies, bed and breakfast uses not covered by section F611.3.8, and multiple dwellings not covered by section F611.3.8. Where work includes the addition or installation of a carbon monoxide source, the construction of a chimney, or the connection of the building to a garage or to any other motor vehicle-related occupancy, a carbon monoxide alarm shall be installed within each dwelling unit or sleeping unit on the lowest story having a sleeping area.

“F611.3.8 **Work completed within Group I-1 occupancy.** Where work includes the addition or installation of a carbon monoxide source, the construction of a chimney, or the connection of the building to a garage or to any other motor vehicle-related occupancy, a carbon monoxide alarm shall be installed on each story having a sleeping area.

“F611.4 **Prohibited locations.** Carbon monoxide alarms shall not be located within or near the openings to garages, bathrooms, or furnace rooms. Carbon monoxide alarms shall also not be located in or near locations specified as ‘prohibited,’ ‘not recommended’ or the like in the manufacturer’s installation instructions.

“F611.5 **Power source.** When the building wiring is served from a commercial or on-site power source, carbon monoxide alarms shall receive their primary power from the building wiring and, when primary power is interrupted, shall receive power from a battery. Wiring shall be permanent and without a disconnecting switch other than those required for overcurrent protection.

“**Exceptions:**

“1. Carbon monoxide alarms installed in buildings without a commercial or on-site power source shall be permitted to be battery operated.

“2. In existing buildings and structures, cord-type, direct plug, or battery-operated carbon monoxide alarms shall be permitted.

“F611.6 **Interconnection.** When more than one carbon monoxide alarm is required to be installed within an individual dwelling unit or sleeping unit, the alarms shall be interconnected.

“**Exception:** Interconnection is not required where cord-type, direct plug, or battery-operated carbon monoxide alarms are permitted.

“F611.7 **Maintenance.** Carbon monoxide alarms shall be maintained in an operative condition at all times, shall be replaced or repaired where defective, and shall be replaced when they cease to operate as intended.

“F611.8 **Disabling of alarms.** Carbon monoxide alarms shall not be removed or disabled, except for service or repair purposes.”

# APPENDIX H

## **Properties & General Combustion Characteristics of Natural Gas**

Pipeline natural gas is one of the most popular fuel choices today. It is called “natural gas” because it is found in the earth as a natural material generated as a result of decaying organic matter. Most pipeline natural gas is called “associated gas” because it is a co-product associated with the oil recovery process. However, other sources of supply include coal bed methane, landfill methane, non-associated gas directly recovered from gas drilling operations, imported re-gasified liquefied natural gas (LNG) and refinery gases. Pipeline natural gas varies in composition depending on the geographic location the gas is being utilized. In fact, one of the many positive attributes of pipeline natural gas is that it can be mixed and blended from various sources and delivered through the interstate pipeline system as a “combined product” sufficient for most end use applications.

However, if the composition of natural gas supplied within a distribution system varies significantly, adjustments to appliances and other devices may be required. Other adjustments that must be considered, although not an issue for most areas served by National Grid, is the effect of elevation on combustion as appliances are certified and tested at sea level and do not take into account the effects elevation has on measured gas / air density. Fortunately, in most cases, after the original installation and adjustment, further adjustments are not necessary if the appliance is installed and maintained properly in accordance with the Manufacturers recommendations and standard good industry practices.

Most pipeline natural gas supplied in commerce is composed of 80-95% methane which is the principal constitute of natural gas. Methane is the same substance produced via decay of organic matter in some swamps, sewers and landfills however, unlike gas from these sources pipeline natural gas contains other hydrocarbon and non-hydrocarbon constituents including:

- Ethane
- Propane
- Butane(s)
- Pentane(s)
- Hexane(s)
- Trace hydrocarbon constituents
- Carbon Dioxide
- Nitrogen
- Trace Sulfur Compounds including gas odorants
- Moisture

Important parameters that describe the combustion characteristics of pipeline gas that are calculated from the composition constituents include:



**Gross Heating Value (also called the “higher heating value” or “heat content”)** – the amount of energy per standard cubic foot of gas transferred as heat from the complete, ideal combustion of the gas with air, at standard temperature, where all the water formed by the combustion reaction condenses to liquid.

**Relative Density (ideal specific gravity)** – the ratio of the specific weight of a gas to the specific weight of dry air at the same conditions of pressure and temperature. It is simply the average molecular weight of the gas divided by the average molecular weight of the gas.

**Wobbe Index (also called the interchangeability factor)** – a numerical value that is determined by dividing the square root of the relative density (a key orifice flow parameter) into the heat content (or Btu per standard cubic foot) of the gas. Basically, the Wobbe Index indicates the relative amount of energy that would flow through a small burner orifice jet.)

It should be noted that pipeline natural gas is non-toxic although sometimes listed as a “hazardous material” due to its flammability. Pipeline natural gas is also typically 40% lighter than air (if air is assumed to have a specific gravity of 1, natural gas would then have a specific gravity of approximately .6 depending on the composition as stated above).

Generally speaking, typical pipeline natural gas distributed in National Grid’s service territory can have heating values in the 1010 – 1060 Btu/scf range with a specific gravity ranging from .58 to .62. This can result in a Wobbe Index range of approximately 1321 – 1360. It should be noted that gas compositional changes may occur and typically should not result in Wobbe Index variations in excess of +/- 4% of the typical adjustment gas, or historical supply at the time of installation. It is anticipated that delivered compositions will not vary above a maximum Wobbe Index of 1,400 and a heating value of 1,110 Btu/scf.

Due to possible variations in composition and resulting combustion parameters, it is important to follow the Manufacturers instructions for properly adjusting burners and setting appliances “on rate”. Failure to do so may result in an over firing condition, combustion problems and lost efficiency. It is the responsibility of the installer to ensure appliances are installed correctly and properly adjusted for the gas received at the time of installation.

Pipeline natural gas used for combustion processes other than household appliances should consult and follow engineering & installation guidelines as to setting combustion devices “on-rate”. Other applications including refueling stations, vehicle and stationary engines also need to consider the above mentioned potential variations in fuel composition and resulting combustion parameters.

**It is important to note that all combustion devices should be maintained in proper working order and inspected regularly to ensure continued safe and efficient operation.**

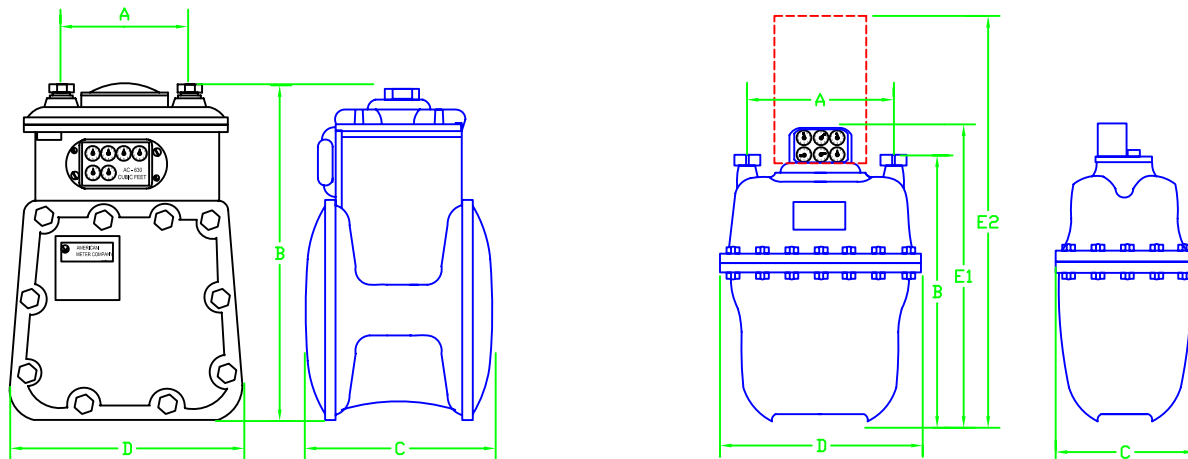
# APPENDIX I

# HARD CASE DIAPHRAM METERS

(For Indoor and Outdoor Applications)

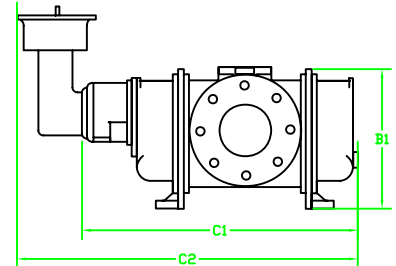
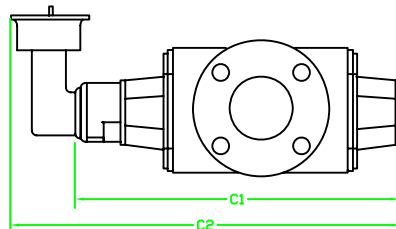
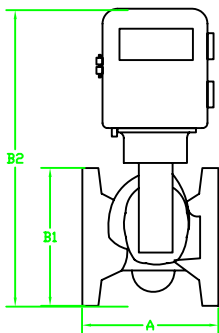
Meter Class	METER TYPE	Manuf	A	B	C	D	E 1	E 2	REF DRAWING	WALL-CNTR OF SWIVL	SWIVL SIZE	PIPE SIZE
250	Metris 250TC	Sprague	7 3/4	11 1/8	6	7 3/4	-	-	A	7	20 LT	1 1/4
	AC250TC	American	6	13 7/8	8 1/2	9 5/8	-	-	A	7	20 LT	1 1/4
	R275TC	Rockwell	6	13 7/8	8 1/2	9 5/8	-	-	A	7	20 LT	1 1/4
400	400ATC (30-Lt)	Sprague	8 1/4	17 1/16	10 3/4	12 1/8	-	-	A	7	45 LT	1 1/4
	AL425TC (30-Lt)	American	8 1/4	14 7/8	10	10 3/4	-	-	A	7	45 LT	1 1/4
	R415TC (30-Lt)	Rockwell	8 1/4	14 7/8	9 3/8	11 1/8	-	-	A	8	45 LT	1 1/4
400	400ATC (45-Lt)	Sprague	8 1/4	17 1/16	10 3/4	12 1/8	-	-	A	7	45 LT	1 1/4
	AL425TC (45-Lt)	American	8 1/4	14 7/8	10	10 3/4	-	-	A	7	45 LT	1 1/4
	R415TC (45-Lt)	Rockwell	8 1/4	14 7/8	9 3/8	11 1/8	-	-	A	8	45 LT	1 1/4
600	AC630TC	American	8 1/4	15	10	10 1/2	-	-	A	7	45 LT	1 1/4
800	800ATC	Sprague	11	26 5/16	13 1/4	14 1/8	23 1/2	-	B	9	45 LT	1 1/2
	AL800TC	American	11	27	14 5/8	17 1/4	24 3/16	-	B	10	45 LT	1 1/2
	R750TC	Rockwell	11	27	14 5/8	17 1/4	24 3/16	-	B	10	45 LT	1 1/2
1000	1000ATC	Sprague	11	26 5/16	16 3/8	18	25	-	B	11	2"	2"
	AL1000TC	American	11	27	13 3/8	14 1/4	23 1/2	-	B	9	2"	2"
	R1000TC	Rockwell	11	27	14	14/34	23 3/4	-	B	10	2"	2"

**NOTE: Meter class "400":** NYC has 30-Lt connections  
Long Island has 45-Lt connections



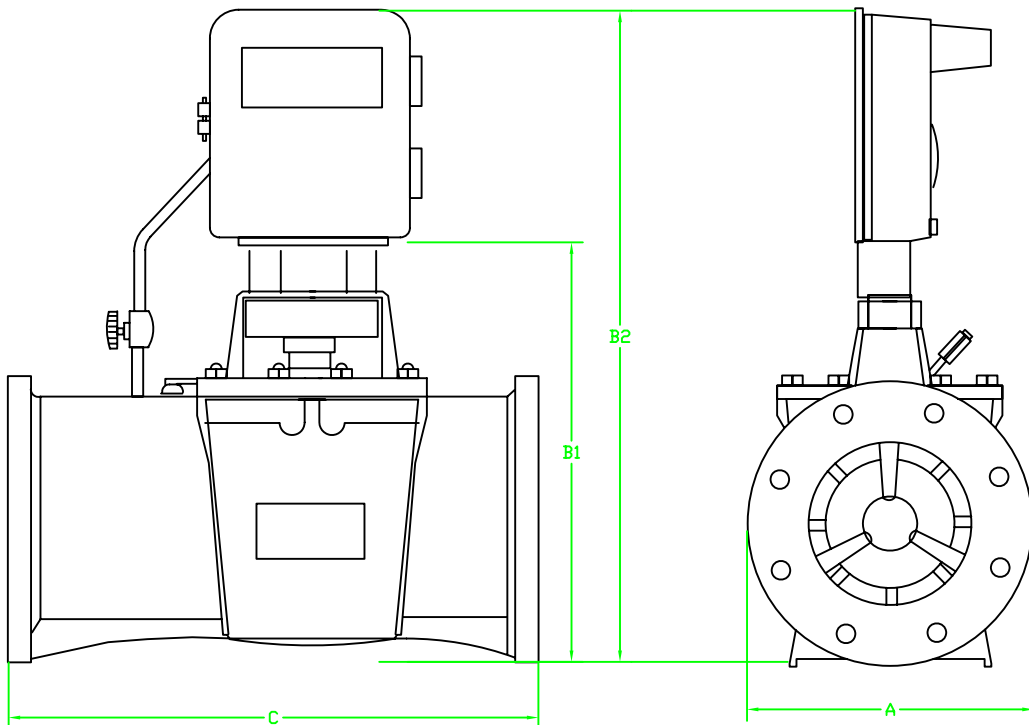
Meter Type	Mfg	A	B 1	B 2	C 1	C 2	Pipe Size
8CTC (non-ID)	Dresser	6 3/4	6 31/32	-	-	19 1/4	2
11CTC (non-ID)	Dresser	6 3/4	6 31/32	-	-	19 3/4	2
15CTC (non-ID)	Dresser	6 3/4	6 31/32	-	-	20 11/16	2
2MTC (non-ID)	Dresser	6 3/4	6 31/32	-	-	20 13/32	2
3MTC (non-ID)	Dresser	6 3/4	6 31/32	-	-	21 5/8	2
5MTC (non-ID)	Dresser	6 3/4	6 31/32	-	-	24 1/2	3
7MTC (non-ID)	Dresser	9 1/2	8 7/8	-	-	24 3/16	3
11MTC (non-ID)	Dresser	9 1/2	8 7/8	-	-	27 3/4	4
16MTC (non-ID)	Dresser	9 1/2	8 7/8	-	-	32 7/16	4
8C-ID (TC or nonTC)	Dresser	6 3/4	6 31/32	-	-	19 1/4	2
11C-ID (TC or nonTC)	Dresser	6 3/4	6 31/32	-	-	19 3/4	2
15C-ID (TC or nonTC)	Dresser	6 3/4	6 31/32	-	-	20 11/16	2
2M-ID (TC or nonTC)	Dresser	6 3/4	6 31/32	-	-	20 13/32	2
3M-ID (TC or nonTC)	Dresser	6 3/4	6 31/32	-	-	21 5/8	2
5M-ID (TC or nonTC)	Dresser	6 3/4	6 31/32	-	-	24 1/2	3
7M-ID (TC or nonTC)	Dresser	9 1/2	8 7/8	-	-	24 3/16	3
11M-ID (TC or nonTC)	Dresser	9 1/2	8 7/8	-	-	27 3/4	4
16M-ID (TC or nonTC)	Dresser	9 1/2	8 7/8	-	-	32 7/16	4
23M-ID (line mounted)	Dresser	9 1/2	8 7/8	-	-	32 3/16	4
38 M- ID	Dresser	18	18	-	-	36 3/4	6
56 M-ID	Dresser	21	18	-	-	40	8
9C - CMTC	American	6 3/4	6 31/32	-	-	19 1/4	2
1.5M - CMTC	American	6 3/4	6 31/32	-	-	20 13/32	2
3.5M - CMTC	American	6 3/4	6 31/32	-	-	21 5/8	2
7M - CMTC	American	9 1/2	8 7/8	-	-	24 3/16	3
11M - CMTC	American	9 1/2	8 7/8	-	-	27 3/4	4

Meters may be installed in a horizontal or vertical position. Vertical (top inlet) is preferred. Check for "Arrow" to indicating proper flow direction  
If applicable, a restricting orifice should be installed at least 2 or 4 pipe diameters downstream of the meter. Before installing, remove plastic end caps and check for free rotation of impellers. Do not put meter under strain at inlet and outlet flange connections and apply no more than 80 FT-LBS of torque when tightening flange bolts. Add oil to all 3 oil reservoirs to the center of the oil level indicator. "Do Not Overfill"



# SENSUS/ROCKWELL TURBINE METERS

Meter					Inlet
Size/Type	A	B1	B2	C	Pipe Size
		Dimensions (inches)			
4" AAT18	9	14 3/16	23 11/16	14	4
4" AAT27	9	14 3/16	23 11/16	14	4
6" AAT35	11	14 3/16	22 1/2	16	6
6" AAT57	11	14 3/16	22 1/2	16	6
8" AAT60	13 1/2	19 11/16	29 3/16	21	8
8" AAT90	11	17 3/16	26 11/16	16	8
12" AAT140	13 1/2	19 11/16	29 3/16	21	12
12" AAT230	19	25 3/16	37 11/16	30	12
4" AAT18 (720#)	10 3/4	12 11/16	23 11/16	14	4
4" AAT27 (720#)	10 3/4	12 11/16	23 11/16	14	4
6" AAT35 (720#)	14	15 1/8	26 11/16	22 1/2	6
6" AAT57 (720#)	14	15 1/8	26 11/16	22 1/2	6
8" AAT60 (720#)	13 1/2	19 11/16	29 3/16	27 1/4	8
8" AAT90 (720#)	11	17 3/16	26 11/16	27 1/4	8
12" AAT140 (720#)	13 1/2	19 11/16	29 3/16	32 1/2	12
12" AAT230 (720#)	19	25 3/16	37 11/16	32 1/2	12



# APPENDIX J

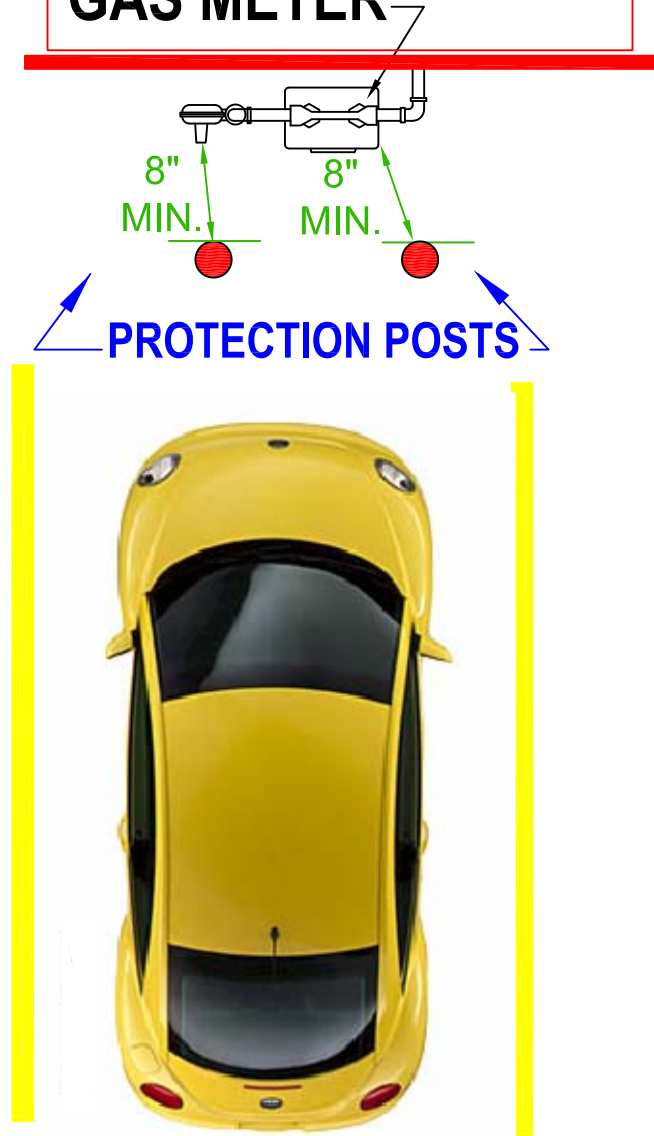
**INDEX OF MOST FREQUENTLY USED STANDARDS: NOTE “-LI” ARE FOR LONG ISLAND AND THE ROCKAWAYS ONLY, “...-NYC” ARE FOR BOTH TERRITORIES**

**THESE STANDARDS ARE ON THE FOLLOWING PAGES**

<a href="#">MTRS-6060-LI-MA-NH-NYC</a>	INSTALLATION OF PROTECTION POSTS
<a href="#">MTRS-6065</a>	TYPICAL INDOOR SINGLE METER CLASS 175 AND 250
<a href="#">MTRS-6075-LI</a>	MULTIMETER INSTALLATION OF HARD CASE METERS
<a href="#">MTRS-6085-LI</a>	TYPICAL MULTIMETER CONFIGURATION FOR 250, 400, 800 & 1000 METERS
<a href="#">MTRS-6095-LI</a>	OUTDOOR MULTIPLE METER HEADERS FOR CLASS 250 METERS
<a href="#">MTRS-6135-LI</a>	LP MAIN/LP METERING FOR 3M OR 7M METER
<a href="#">MTRS-6140-LI-NYC</a>	SINGLE METER AND REGULATOR FOR OUTSIDE SET 15-124 PSIG INLETS, 250 & 400 METERS ½” AND ¾” DIAMETER SERVICES
<a href="#">MTRS-6142-LI-NYC</a>	SINGLE METER AND REGULATOR FOR OUTSIDE SET 15-124 PSIG INLETS, 250 & 400 METERS 1” AND 1-1/4” DIAMETER SERVICES
<a href="#">MTRS-6145-LI</a>	LP MAIN/LP METERING FOR 3M AND 7M HORIZONTAL ROTARY GAS METER – OUTSIDE LOCATIONS
<a href="#">MTRS-6185-LI</a>	OUTDOOR METER SETS CLASS 800/1000, LP-124 PSIG INLET SERVICES – LP AND ½ PSIG DELIVERY PRESSURE
<a href="#">MTRS-6215-LI</a>	TYPICAL MULTIMETER CONFIGURATIONS FOR CLASS 250, 400, 800 AND 1000 METERS WITH SINGLE REGULATOR
<a href="#">MTRS-6255-LI</a>	HP MAIN/LP, ½ PSIG AND 1 PSIG METERING FOR 8C, 1.5M, 3M OR 7M VERTICAL ROTARY GAS METER
<a href="#">MTRS-6265-LI</a>	HP MAIN/LP, ½ PSIG AND 1 PSIG METERING FOR 8C, 1.5M, 3M OR 7M HORIZONTAL ROTARY GAS METER
<a href="#">MTRS-6335-LI</a>	OUTDOOR GAS METER CLASS 250/400 WITH BYPASS
<a href="#">MTRS-6385-LI</a>	8C, 1.5M, 3M & 7M HP METER, VERTICAL POSITION
<a href="#">MTRS-6505-LI</a>	CONCRETE FOUNDATIONS AND/OR FOOTINGS FOR GAS ROTARY GAS METER HEADERS – OUTDOOR LOCATION
<a href="#">MTRS-6545-LI</a>	GENERAL NOTES FOR ROTARY GAS METERS
<a href="#">020010-CS</a>	8C – 3M PREFABRICATED HEADER 800 – 3,000 SCFH
<a href="#">020011-CS</a>	5M AND 7M PREFABRIATED METER HEADER UP TO 7,000 SCFH
<a href="#">0200130-CS</a>	OUTDOOR LOCATION FOR RISERS AND REGULATOR VENT TERMINUS
000-0000	GENERATOR INSTALLATION USING 1 METER/2 REGULATORS

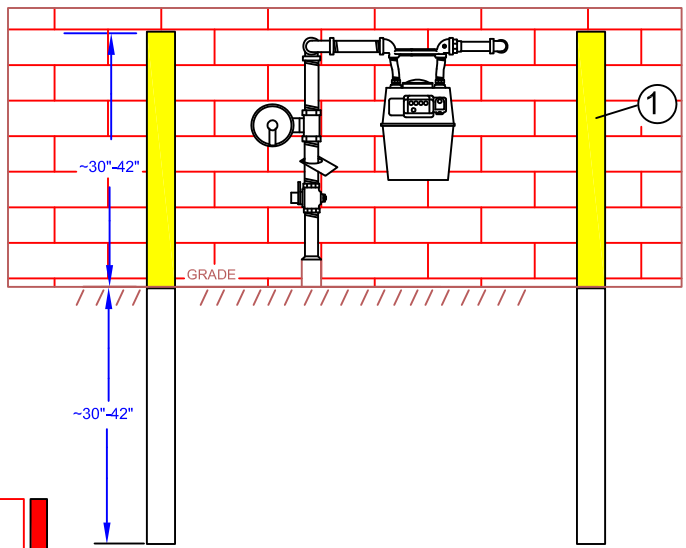
**DISCLAIMER:** The standards with the “-LI” suffix are for Long Island and the Rockaways only. The standards that include “NYC” in the suffix are valid in New York City as well. These standards are current as of December 2005. They may be revised at any time. It is up to the installing Contractor to verify the latest edition with National Grid’s Project Manager, Gas Customer Service or Field Operations Representative.

# GAS METER

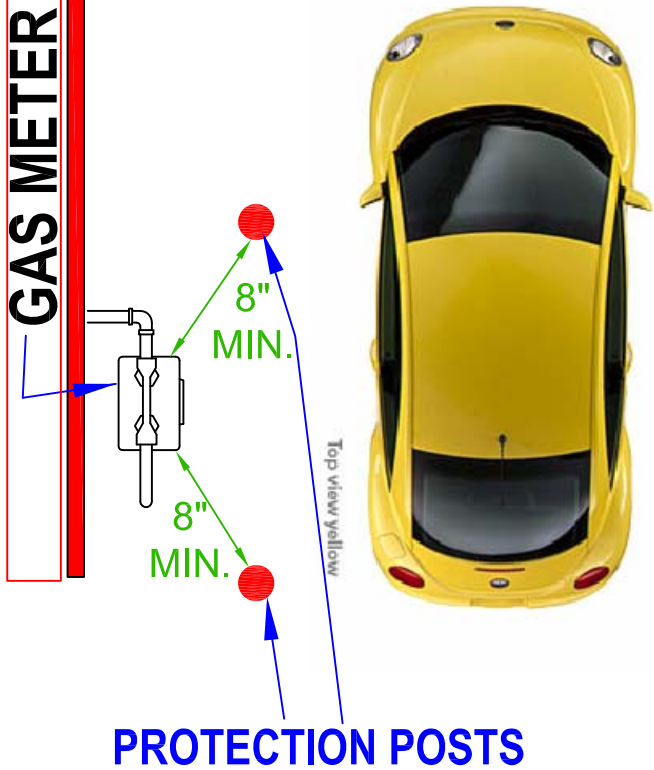


**FIGURE 1**

**HEAD ON PARKING**



# GAS METER



**FIGURE 2**

**DRIVEWAY OR ADJACENT PARKING**

**nationalgrid**

ALL REGIONS

## INSTALLATION OF PROTECTION POST OUTSIDE METER SETS

REVISIONS: MADE APPLICABLE TO ALL REGIONS

DATE: 07/01/2003

EFFECTIVE DATE: 09/15/2013

DESIGN: PG

STD. DWG.  
NO.

**MTRS-6060**

DRAWN: PG

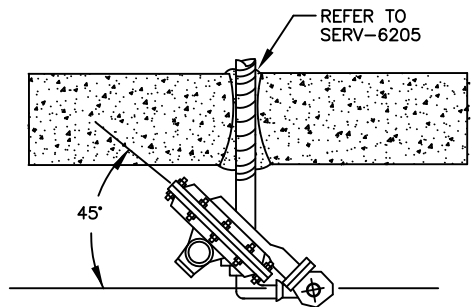
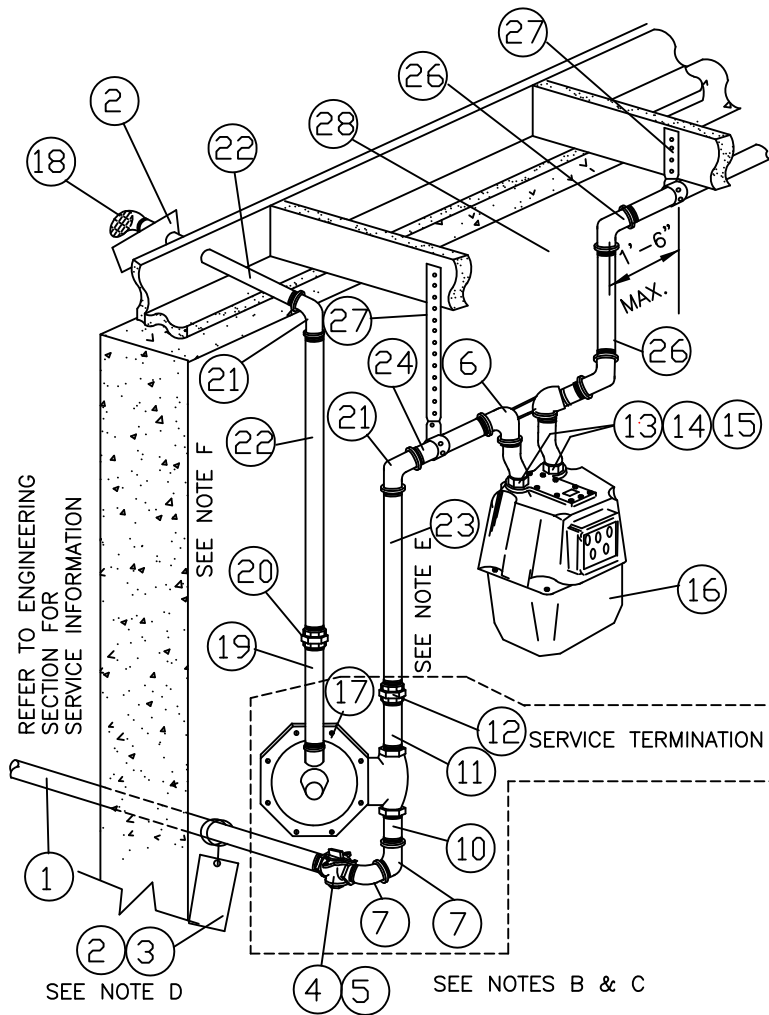


**NOTES:**

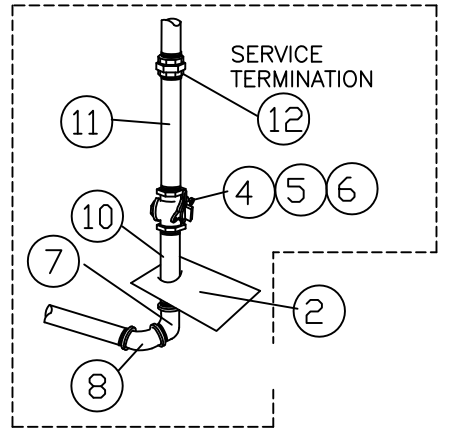
- A. WHERE PRACTICAL, CUSTOMER METERS AND SERVICE REGULATORS SHOULD BE INSTALLED IN AN AREA AWAY FROM VEHICULAR TRAFFIC AND OTHER POTENTIAL HAZARDS.
- B. WHENEVER THE METER AND/OR SERVICE REGULATOR ASSEMBLY IS POTENTIALLY SUBJECT TO DAMAGE FROM VEHICULAR TRAFFIC, AND NO OTHER MEANS OF PROTECTION EXISTS (E.G., CURB STOP, RETAINING WALL, ELEVATED PLATFORM, ETC.) PROTECTION POST(S) SHALL BE INSTALLED.
- C. EXAMPLES OF METER/SERVICE RISER LOCATIONS REQUIRING PROTECTION SHALL INCLUDE BUT NOT BE LIMITED TO:
  - 1) WHERE THE METER/SERVICE RISER IS LOCATED AT THE END OF A DRIVEWAY (SEE FIG. (1.))
  - 2) WHERE THE METER/SERVICE RISER IS LOCATED ADJACENT A DRIVEWAY (SEE FIG. (2.))
  - 3) WHERE THE METER/SERVICE RISER IS LOCATED IN A PARKING LOT
  - 4) WHERE THE METER/SERVICE RISER IS LOCATED IN A LOADING AREA
- D. RESPONSIBILITY FOR METER PROTECTION SHALL BE DETERMINED ON A CASE BY CASE BASIS.
- E. PROTECTION POSTS SHOULD MAINTAIN A MINIMUM CLEARANCE OF EIGHT (8) INCHES AROUND THE METER AND REGULATOR
- F. FOR CERTAIN COMMERCIAL AND INDUSTRIAL APPLICATIONS ADDITIONAL PROTECTION MAY BE REQUIRED IN EXCESS OF THIS POLICY DOCUMENT.
- G. THE INSTALLATION OF PROTECTION POSTS SHOULD BE DOCUMENTED ON THE GAS SERVICE RECORD CARD.
- H. THE POSTS FOR RESIDENTAL OR SMALL COMMERCIAL SETS SHOULD BE 3-1/2 OR 4 INCHES OD STEEL, PAINTED OR GALVANIZED, AND 5-7 FEET IN LENGTH. WHERE FEASIBLE, FILL POSTS WITH CONCRETE.  
**NOTE: 2" GALV. STEEL IS CURRENTLY USED IN UNY AND ACCEPTABLE FOR RESIDENTAL AND SMALL COMMERCIAL INSTALLATIONS.**
- I. THE POST SHOULD BE SET 30-42 INCHES ABOVE AND 30-42 INCHES BELOW GRADE. ALTERNATES ARE PERMISSIBLE IF THE ABOVE MATERIAL IS NOT IN STOCK. OBTAIN APPROVAL FROM YOUR SECTION MANAGER OR CHECK WITH GAS ENGINEERING IF YOU ARE UNCERTAIN.
- J. FOR CERTAIN COMMERCIAL AND INDUSTRIAL APPLICATIONS, ADDITIONAL PROTECTION MAY BE REQUIRED IN EXCESS OF THIS STANDARD

		SAP ITEM ID'S
2	CONCRETE – READY MIX 40 LB. BAG (SEE NOTE F)	9331384 LI, NYC
1	POST 3.5" O.D. 6' LONG – CONCRETE FILLED - PRIMED COATED OR POST 4.5" O.D. 5' LONG GALVANIZED 0.237" WALL – <b>NOT CONCRETE FILLED</b> POST 3.5" OD 7' LONG – CONCRETE FILLED POST 2" GALVANIZED .154" WALL + CAP FOR 2" POST POST 6" STEEL .280" WALL (FOR LARGE COMMERCIAL SETS IN UNY) + OUTER YELLOW PLASTIC SLEEVE	9340162 LI, NYC, MASS 9340113 LI, NYC, MASS 9310316 RI, MASS 9312317 UNY 9312317 UNY 9312325 UNY 9308350 UNY
NO.	ITEM	CODE No.

**BILL OF MATERIAL**




PLAN VIEW AT REGULATOR



FOR LOW PRESSURE SERVICE

FOR HIGH PRESSURE SERVICE

 <p>LONG ISLAND</p>	<b>TYPICAL INDOOR SINGLE METER CLASS 175 AND 250</b>	
	<b>REVISIONS:</b> REVISED USING SAP ITEM ID #'S	DATE: 07/01/2003 DESIGN: JAL DRAWN: H. F.

**NOTES**

- A. THIS CONSTRUCTION STANDARD SHALL BE LIMITED IN USE TO THOSE TO THOSE SERVICE WHERE AN OUTSIDE METER SET. CANNOT BE INSTALLED.
- B. KED SHALL SUPPLY AND INSTALL ITEMS 1 THROUGH 18 INCLUSIVE.
- C. AFTER PURGING THE SERVICE AND BEFORE INSTALLING THE METER, THE LOCK WING METER COCK (ITEM 4) SHALL BE LOCKED WITH A GAS SNAP LOCK (ITEM 5).
- D. FOR HIGH PRESSURE SERVICES, THE GAS SERVICE LOCATION TAG (ITEM 2) IS TO BE TEMPORARILY STRAPPED ON TO THE PIPING BEFORE THE LOCK WING METER COCK. ONCE THE REGULATOR VENT PIPE IS INSTALLED THE TAG SHALL BE REMOVED AND INSTALLED ON THE OUTSIDE VENT LINE BETWEEN THE VENT AND THE OUTSIDE WALL. A DUPLICATED TAG MAY HAVE TO BE INSTALLED IF AN EXCESS FLOW VALVE EXIST. SEE SERV-6300 FOR ADDITIONAL REQUIREMENTS .
- E. THE PIPING (ITEM 23) ABOVE THE INSULATING UNION SHALL BE SIZED SO THAT THE TOP OF THE METER IS NOT OVER 6' ABOVE THE FLOOR. THE BOTTOM OF THE METER SHOULD NOT BE LESS THAN 6" FROM THE FLOOR AND PREFERABLY AT 4' ABOVE THE FLOOR.
- F. THE TYPICAL VENT PIPING ARRANGEMENT IS SHOWN (ITEM 22). HOWEVER, THE SIZE, LENGTH AND NUMBER OF ELBOWS MUST MEET THE REQUIREMENTS SECTION 2, ENGINEERING DESIGN
- G. THIS STANDARD CAN BE FOR METER SETS INSTALLED IN A GARAGE PROVIDED THAT THE RISER AND METER SET IS LOCATED TO PREVENT PHYSICAL DAMAGE FROM VEHICLE MOVEMENT OR OTHER DEVICES. REFER TO MTRS-6060 FOR ADDITIONAL REQUIREMENTS.
- H. INDOOR PIPING AND FITTINGS CAN BE NON GALVANIZED (BLACK) WITH THE EXCEPTION OF THE VENT PIPING THAT EXTENDS OUTSIDE TO THE VENT. THIS MUST BE GALVANIZED.

N/R NOT REQUIRED

+ AS REQUIRED

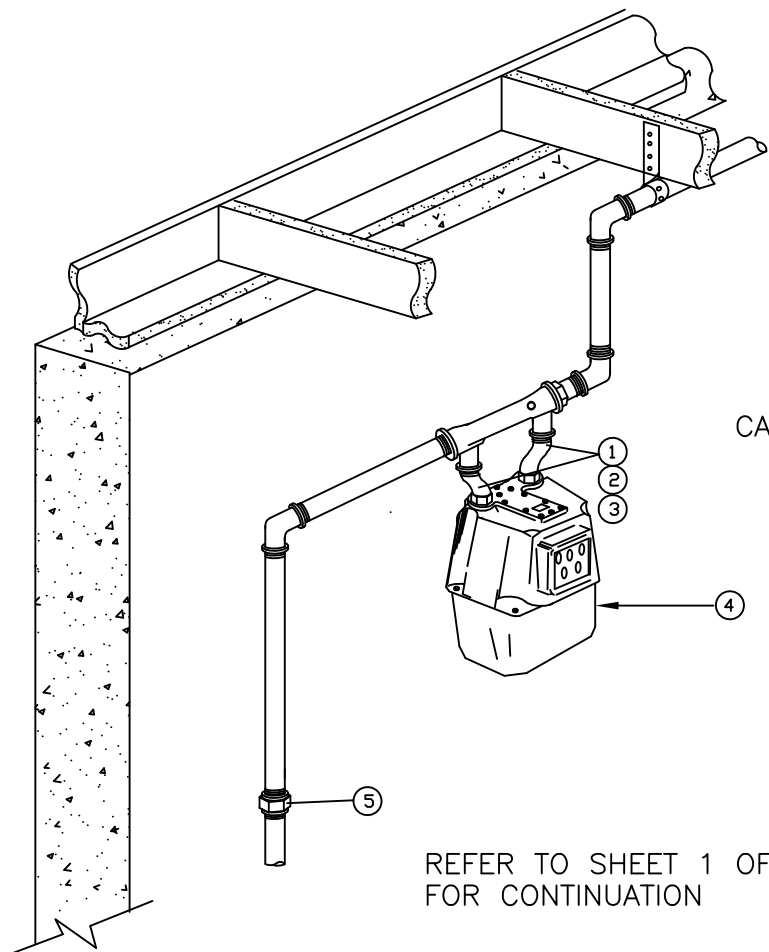
\*\* TO BE SUPPLIED AND INSTALLED BY THE CUSTOMER.

X X SUPPLIED BY FIELD OPERATIONS

		QUAN TITY	HIGH PRESSURE	QUAN TITY	LOW PRESSURE
28	ELBOW AS SIZE REQUIRES	+	**	+	**
27	CUSTOMER HOUSE LINE SUPPORT	+	**	+	**
26	CUSTOMER HOUSE LINE	+	**	+	**
25					
24	NIPPLE – 1" X 6"	1	**	1	**
23	PIPE – 1" X LENGTH REQUIRED - STEEL	+	**	+	**
22	PIPE – 1" – STEEL – STRAIGHT LENGTH	+	**		N / R
21	ELBOW – 1"	3	**	2	**
20	UNION – 1" - INSULATING	1	**		N / R
19	NIPPLE – 1" X 6"	1	**		N / R
18	VENT – 90 DEGREE X 1" - SCREENED	1	9358640		N / R
17	REGULATOR – 3/4" X1"WITH 1/8" ORIFICE	1	9383047		N / R
16	GAS METER	1	XX	1	XX
15	WASHER – 20 LIGHT METER	2	9342478	2	9342478
14	NUT – METER – 3/4" X 20 LT	2	9340787	2	9340787
13	SWIVEL METER – 1" X 20 LT	2	9383109	2	9383109
12	UNION – 1" - INSULATING	1	9341684	1	9341684
11	NIPPLE – 1" X 3"	1	9340641	1	9340641
10	NIPPLE – 3/4" X 6"	1	9340637	1	9340637
9	UNUSED				
8	ELBOW – 1 1/4" X 3/4" – STREET - REDUCING		N / R	2	9341198
7	ELBOW – 3/4" - STREET				
6	METER BAR 1" X 1" X 1"	1	9383181	1	9383181
5	GAS SNAP LOCK	1	9330915	1	9330915
4	METER COCK – LOCKWING – 3/4"	1	9339593	1	9339593
3	STRAP – 14" – NYLON – SELF LOCKING	1	9325971		N / R
2	TAG – GAS SERVICE LOCATION	1	9340255	1	9340255
1	PIPE – SERVICE - TUBING	+	+	+	+

No.	ITEM	KED CODE No.
-----	------	--------------

**BILL OF MATERIAL**



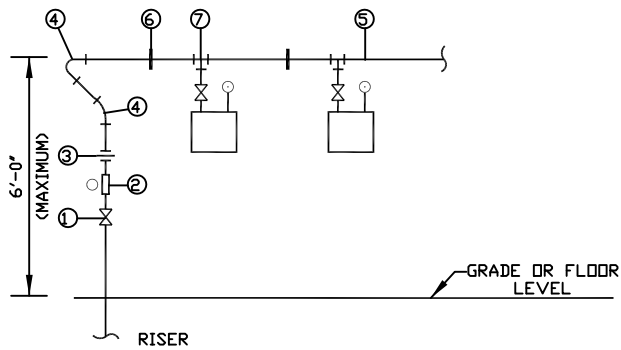
TYPICAL CONVERSION OF  
5 LIGHT TIN METER TO HARD  
CASE CLASS 175/250 GAS METER

REFER TO SHEET 1 OF 3  
FOR CONTINUATION

This standard sheet 3 of 3, is not to be used for NEW construction. For new construction, refer to the sheet 1 of 3. This standard sheet, 3 of 3, shall be used only when replacing a 5 Light Tin Gas Meter with a hard Case Class 175/250 Gas Meter.

BILL OF MATERIAL			
ITEM NO.	DESCRIPTION	QUAN-TITY	M & S CODE
1.	Swivel - Meter - 1/2" x 20 Light	2	9342427
2.	Nut - Meter - 20 Light	2	9340787
3.	Washer - 20 Light Meter	2	9342478
4.	Meter - HC Gas - Class 175/250	1	XX
5.	Union - 3/4" - Insulating	1	9341688

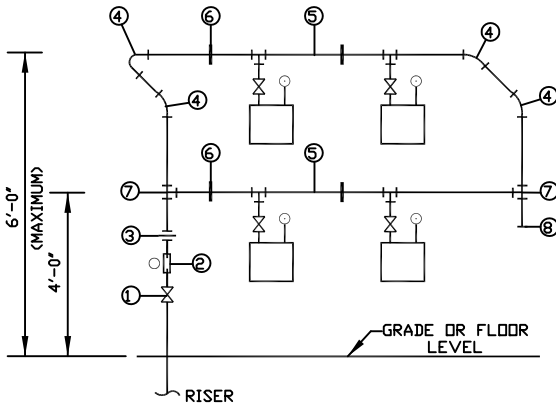
XX Supplied by field Operations.



(A) TWO OR THREE METERS MAXIMUM MOUNTED IN A SINGLE TIER AND SUPPLIED BY A SINGLE REGULATOR (CLASS 175 AND 250)

REFERENCE DRAWINGS:  
MTRS-6095  
MTRS-6105

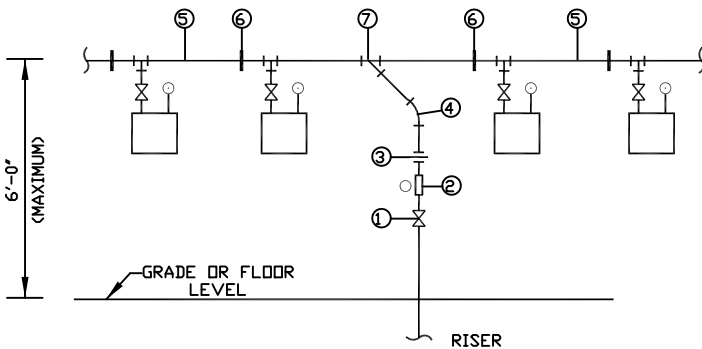
**PREFERRED METHOD**



(B) MULTIMETER "STACKED" FOR TWO OR MORE METERS (CLASS 250, 400, 800 AND 1000)

REFERENCE DRAWINGS:  
MTRS-6215 (SINGLE REGULATOR)  
MTRS-6225 (DUAL REGULATOR)  
(FOR INSIDE SETS, CLASS 175 AND 250)

**ALTERNATE METHOD**



(C) ALTERNATE INSTALLATION FOR TWO TO FOUR METERS MAXIMUM T-CONFIGURATION (CLASS 250, 400, 800 AND 1000)

REFERENCE DRAWINGS:  
MTRS-6085 (SINGLE REGULATOR)

**nationalgrid**

LI

**MULTIMETER INSTALLATION  
HARD CASE METERS**

**REVISIONS:** REVISED USING SAP ITEM ID #'S

DATE: 7/1/2003

EFFECTIVE DATE: 07/15/2013

DESIGN: MLoP

STD. DWG.

DRAWN: MLoP

NO.

**MTRS-6075**

ITEM	DESCRIPTION
1	VALVE (SCREW TYPE OR FLANGE)
2	SERVICE REGULATOR
3	UNION
4	90° BEND ELBOW
5	PIPE
6	SUPPORTS-PIPE, ROD OR HANGERS
7	TEE
8	DRIP LEG WITH CAP

### NOTES:

1. THIS STANDARD IS PROVIDED TO INDICATE THE AVAILABLE METERING STANDARDS FOR HANDLING COMMERCIAL CUSTOMERS HAVING MULTIPLE HARD CASE METERS.
2. INSIDE METER SETS SHALL ONLY BE INSTALLED WHEN, IN THE COMPANIES OPINION, AN OUTSIDE SET IS NOT PRACTICAL. INSIDE METER SETS SHALL NOT BE INSTALLED ON 99 AND 124 P.S.I. GAS SERVICE.
3. REFER TO CONSTRUCTION STANDARD MTRS-6215 FOR ADDITIONAL REQUIREMENTS AND NOTES ON TYPICAL MULTIMETER SET INSTALLATIONS. THE PROPER MANIFOLD PIPING SIZES ARE ALSO PROVIDED ON A TABLE IN MTRS-6215.
4. VENT PIPING SHALL BE INSTALLED PER SERV-6225.
5. THE EXACT LAYOUT, BILL OF MATERIAL AND ADDITIONAL NOTES CAN BE FOUND ON THE APPROPRIATE REFERENCED CONSTRUCTION STANDARD.
6. DUAL REGULATORS CAN BE INSTALLED TO OBTAIN THE REQUIRED CAPACITY (WITH GAS ENGINEERING'S APPROVAL) THEY CAN ALSO BE USED WHEN CONTINUITY OF SERVICE IS A PRIORITY AS AGREED TO BY NATIONAL GRID GAS SALES AND GAS ENGINEERING.

# "T" CONFIGURATION

SEE NOTE E, SHEET 2 FOR INSTALLATION OF ADDITIONAL METER.

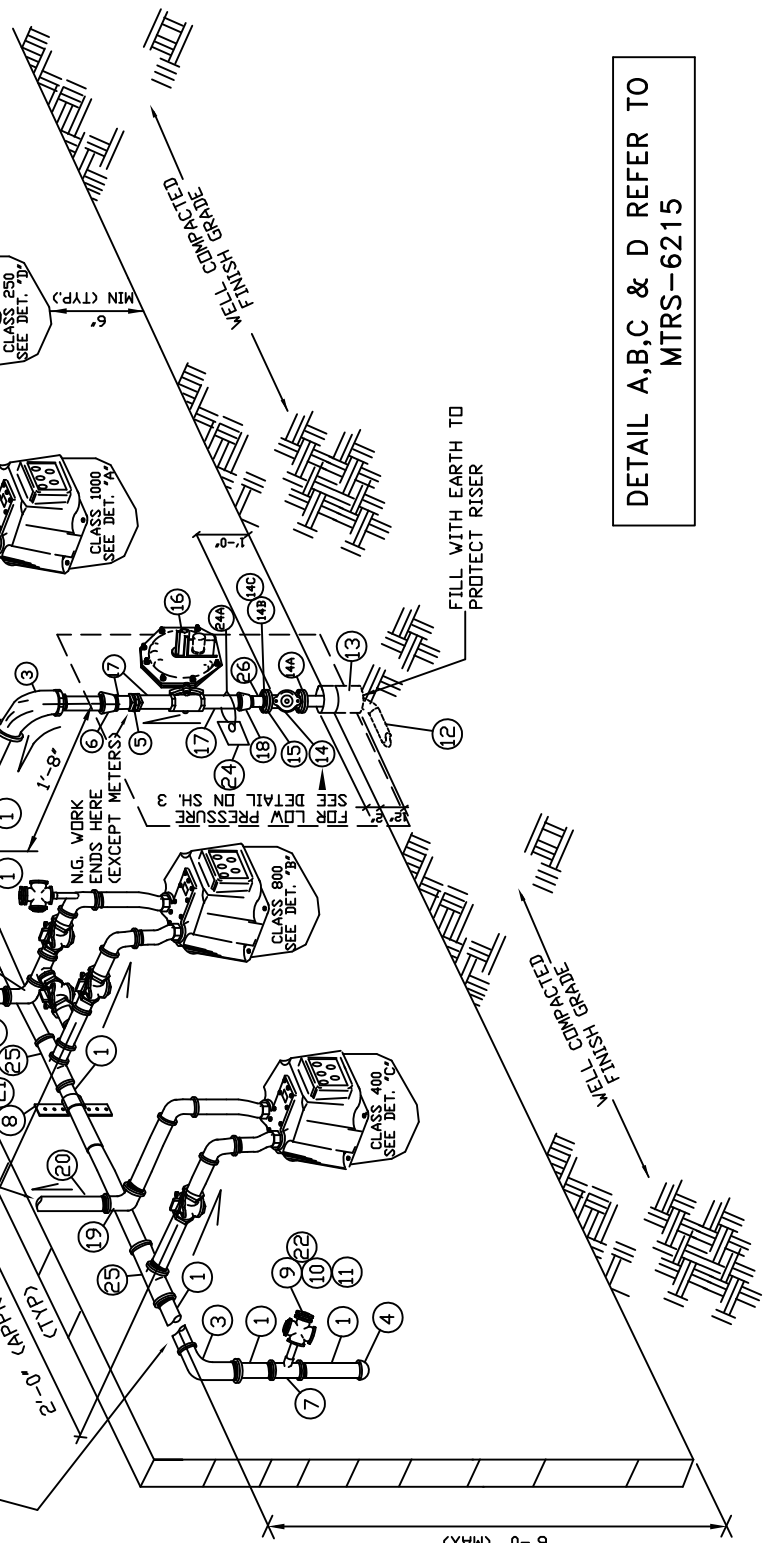
TO CUSTOMER'S HOUSE LINE

2'-0" (APPRX) (TYP)

SEE NOTE E, SHEET 2 FOR INSTALLATION OF ADDITIONAL METER.

TO CUSTOMER'S HOUSE LINE

2'-0" (APPRX) (TYP)



DETAIL A,B,C & D REFER TO MTRS-6215

**nationalgrid**  
LONG ISLAND

## TYPICAL MULTIMETER CONFIGURATION FOR CLASS 250, 400, 800 AND 1000 WITH SINGLE AND DUAL REGULATORS

**REVISIONS:** REVISED USING SAP ITEM ID #'S

DATE: 07/01/2003  
DESIGN: GJK  
DRAWN: MLoP

EFFECTIVE DATE: 09/15/2013  
STD. DWG. NO. **MTRS-6085**

**NOTES**

- A. NAT. GRID WILL SUPPLY AND INSTALL ITEMS 12 THRU 18 AND ITEMS 22 THRU 24A.
- B. SEE MTRS – 6215 FOR DIFFERENT METER HEADER PIPE SIZES.
- C. FOR ITEM ID'S FOR ITEMS 27 THRU 43 ON SEE SHEETS 4 THRU 7 FOR APPROPRIATE METER CLASS.
- D. FOR HIGH AND LOW PRESSURE INSTALLATIONS; USE A THREADED TYPE VALVE WHEN THE OUTLET OF RISER IS 1 ¼” AND A FLANGE VALVE WITH GASKETS AND ETC. WHEN THE RISER OUTLET IS 2” OR LARGER .
- E. ADDITIONAL METER SETS CAN BE ADDED BY THE USE OF A FULL TEE (ITEM 25). SEE SHEET 1.
- F. FOR ADDITIONAL NOTES SEE MTRS- 6215.
- G. **CUSTOMER TO INSTALL BRASS OR ALUMINUM PERMANENT ID TAG ON EACH METER STAMPED OR ENGRAVED WITH STORE # / APARTMENT NUMBER/ UNIT # OR ADDRESS.**
- H. DO NOT EXCEED 3 METERS IN ONE BRANCH. AFTER 3 METERS, INSTALL A LOOPED PIPING HEADER AS SHOWN IN MTRS-6215.

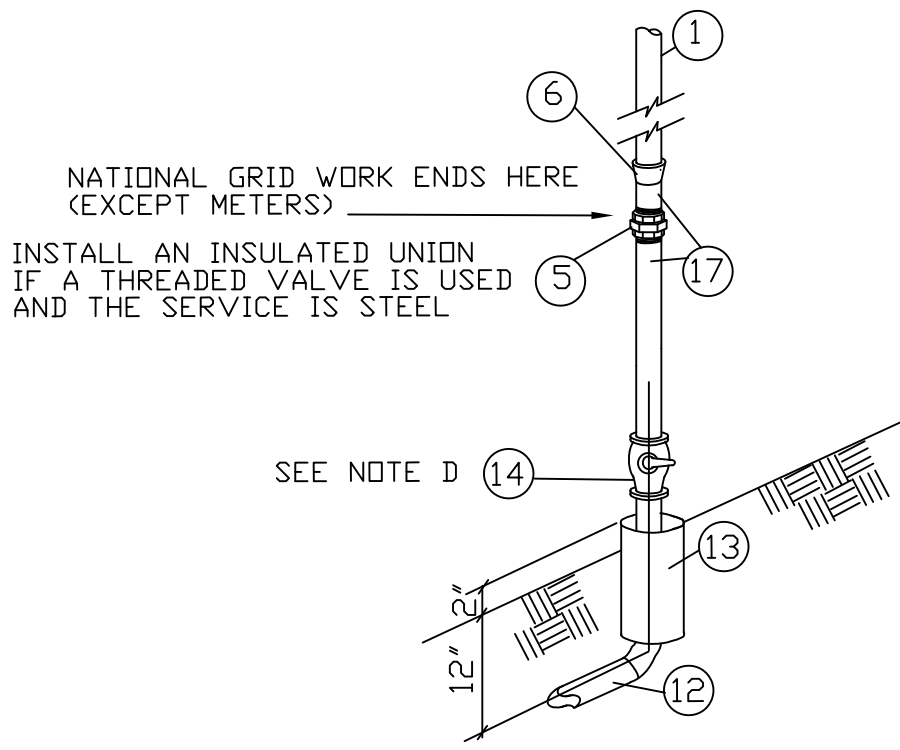
LEGEND :

- + - AS REQUIRED
- ++ - TO BE SUPPLIED BY FIELD OPERATIONS
- \*\* - SUPPLIED BY CUSTOMER

26	NIPPLE – AS REQUIRED	+	NAT. GRID
25	TEE: 1 PER METER – SIZE AS REQUIRED (SEE DET. A,B,C,D, MTRS-6215)	+	**
24A	STRIP – 14” – SELF LOCKING - NYLON	1	9325971
24	TAG – GAS SERVICE LOCATION (CPR TAG)	1	9340255
23	UNION – GALVANIZED, HOUSE LINE SIZE	+	**
22	GAS SNAPLOCK	2	9330915
21	SUPPORT PIPE OR ROD – 1” (OPTION)	+	**
20	HOUSE LINE – SIZE AND QUANTITY AS REQ'D	+	**
19	ELBOW – SIZE AND QUANTITY AS REQ'D	+	**
18	REDUCER (IF REQUIRED)	1	NAT. GRID
17	NIPPLE	+	NAT. GRID
16	REGULATOR – 1 ¼” OR 2” – RELIEF / MONITOR	1	*
15	GASKET RING	1	NAT. GRID
14C	FLANGE – WELD NECK (FOR FLANGED TYPE VALVE ONLY)	2	NAT. GRID
14B	BOLT – 5/8” X 2 ¾” A3 07– MACHINE	8	9339766
14A	GASKET – INSULATED FLANGE KIT	1	NAT. GRID
14	VALVE (SEE #4 BELOW)	1	NAT. GRID
13	SLEEVE – PIPE – PLASTIC OR EQUIVALENT	1	NAT. GRID
12	RISER – SERVICE (PRIMED & PAINTED) – SIZE AS REQUIRED	1	NAT. GRID
11	PLUG- 3 / 4” – THREADED	2	**
10	METER COCK – 3 / 4” – LOCKWING	2	**
9	NIPPLE – ¾” X 3”	2	**
8	CHANNEL – 1 5 / 8”UNISTRUT W/CLAMP (SEE ITEM 21)	+	**
7	TEE – BULL – SIZE AS REQUIRED	2	**
6	REDUCER (IF REQUIRED)	1	**
5	UNION – INSULATED (ONLY IF SCREWED VALVE IS USED AND SERVICE IS STEEL)	1	**
4	CAP	2	**
3	ELBOW – 90 DEGREE	3	**
2	TEE – (EQUAL TO SIZE OF HEADER)	1	**
1	PIPE – AND LENGTH AS REQ'D (REFER TO NOTE C)	+	**
			4 METER SETS
<b>No.</b>	<b>ITEM</b>	<b>NAT. GRID</b>	
<b>BILL OF MATERIAL</b>			



↑ FOR CONTINUATION  
SEE SH. 1



NATIONAL GRID WORK ENDS HERE  
(EXCEPT METERS)

INSTALL AN INSULATED UNION  
IF A THREADED VALVE IS USED  
AND THE SERVICE IS STEEL

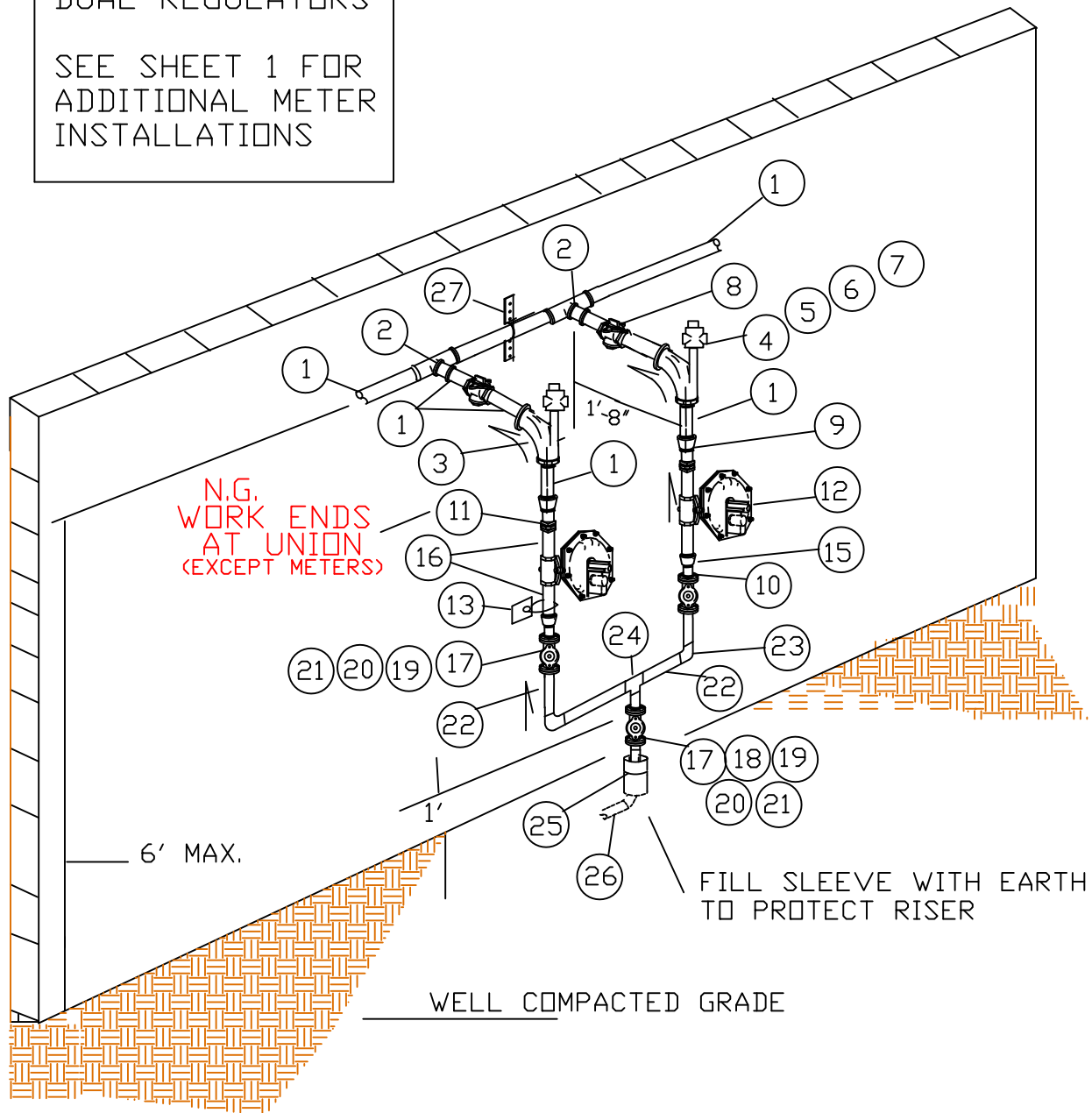
SEE NOTE D

RISER CONFIGURATION  
FOR LOW PRESSURE SERVICE

SEE SHEET 2 OF 5 FOR BILL OF MATERIAL

"T" CONFIGURATION  
DUAL REGULATORS

SEE SHEET 1 FOR  
ADDITIONAL METER  
INSTALLATIONS



**NOTES**

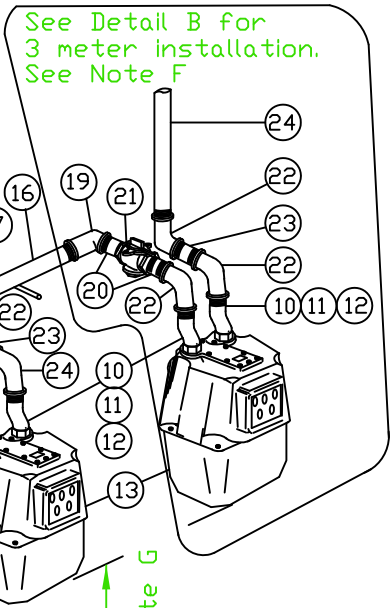
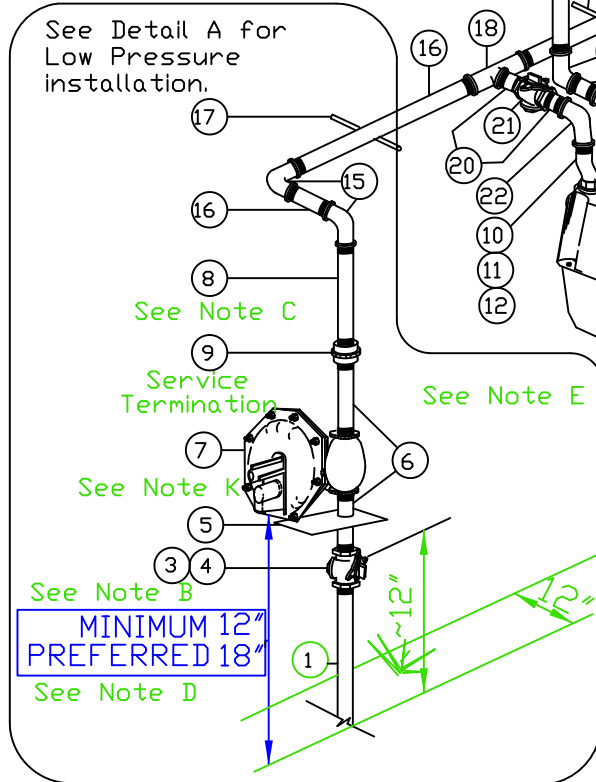
1. SEE SHEET 3 OF MTRS-6215 FOR DIFFERENT METER HEADER PIPE SIZES.
2. FOR ADDITIONAL NOTES REGARDING METER HEADER CONFIGURATIONS SEE MTRS-6215.
3. PARALLEL REGULATORS ARE TO BE INSTALLED ONLY WHEN CONTINUITY OF SUPPLY IS A PRIORITY FACTOR. BOTH FIELD OPERATIONS AND GAS CONSTRUCTION MUST AGREE ON FINAL DESIGN PRIOR TO GIVING CUSTOMER APPROVAL. ALSO SEE NOTE I ON MTRS-6545.
4. USE A SCREW TYPE VALVE FOR 1 1/4" RISER AND A FLANGE TYPE VALVE FOR 2" RISERS. (ITEM 17). IF ITEM 17 IS A SCREW VALVE ITEMS 18, 19, 20 AND 21 IS NOT REQUIRED.

- \* SEE CMS-03002 FOR PROPER REGULATOR , SELECTION AND SIZING  
 + AS REQUIRED  
 \*\* TO BE SUPPLIED BY CUSTOMER

27	1 5/8" STRUT CHANNEL WITH CLAMP	+	**
26	RISER – SERVICE – SIZE AS REQUIRED	1	NAT. GRID
25	SLEEVE – PIPE PLASTIC OR EQUIVALENT	1	NAT. GRID
24	TEE 3WAY – SIZE AS REQUIRED	1	
23	ELBOW 90 DEG. – SIZE AS REQUIRED	2	NAT. GRID
22	NIPPLE – SIZE AS REQUIRED	+	
21	FLANGE – SIZE AS REQUIRED	6	
20	GASKET – SIZE AS REQUIRED	5	
19	BOLTS – 5/8" X 2 3/4"	24	NAT. GRID
18	GASKET – INSULATED – SIZE AS REQUIRED	1	
17	VALVE – SIZE AS REQUIRED (SEE NOTE 4 )	3	
16	NIPPLE – SIZE AS REQUIRED	+	NAT. GRID
15	REDUCER – SIZE AS REQUIRED	2	NAT. GRID
14	STRAP – SELF LOCKING	2	9325971
13	TAG – GAS SERVICE LOCATION	1	9340255
12	REGULATOR – 1-1/4 " OR 2" RELIEF / MONITOR	2	*
11	UNION – IF REQUIRED	2	NAT. GRID
10	NIPPLE – SIZE AND LENGTH AS REQUIRED	2	NAT. GRID
9	REDUCER – IF REQUIRED	2	**
8	VALVE – SCREW – SIZE EQUAL TO HEADER DIAMETER	2	**
7	GAS SNAP LOCK	2	9330915
6	PLUG – 3/4" SCREW	2	**
5	NIPPLE 3/4" X 3"	2	**
4	VALVE – LOCKWING 3/4"	2	**
3	TEE – HEEL SIZE X 3/4"	2	**
2	TEE - 3 - WAY – SIZE AS REQUIRED	2	**
1	PIPE – SIZE AND LENGTH AS REQUIRED	+	**
<b>No.</b>	<b>ITEM</b>	<b>NAT. GRID CODE No.</b>	
<b>BILL OF MATERIAL</b>			

**NOTE:** When 3 meters are to be installed which has a maximum load of 750 Cubic Feet per Hour, the manifolds shall be a minimum of 1 1/4" in diameter. See note I

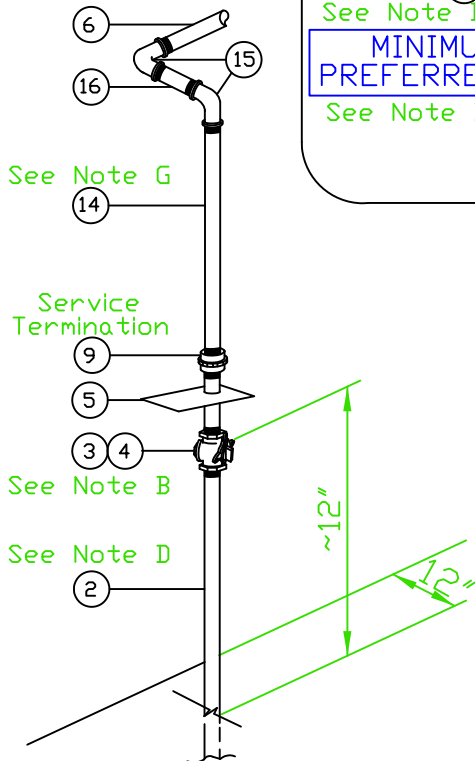
**HIGH PRESSURE**



**LOW PRESSURE INSTALLATION**

**DETAIL A**

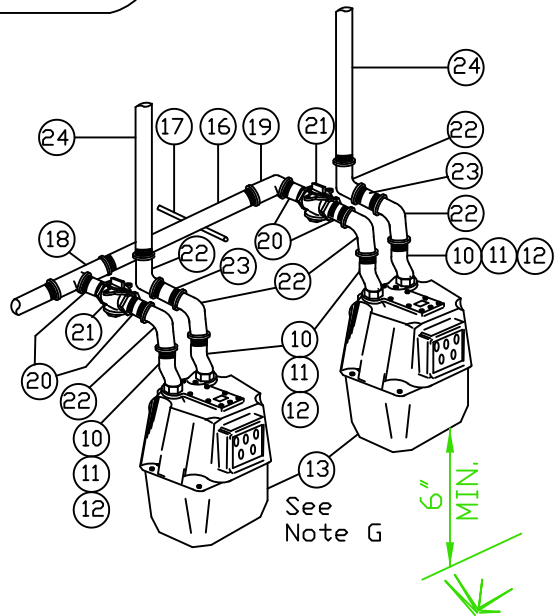
See Notes A and C



**3 METER INSTALLATION**

**DETAIL B**

See Note F



**nationalgrid**

LONG ISLAND

**OUTDOOR MULTIPLE METER HEADERS FOR CLASS 175 OR 250 C.F.H. METERS**

**REVISIONS:** REVISED USING SAP ITEM ID #'S

DATE: 07/01/2003

EFFECTIVE DATE: 09/15/2013

DESIGN: MLoP

STD. DWG.

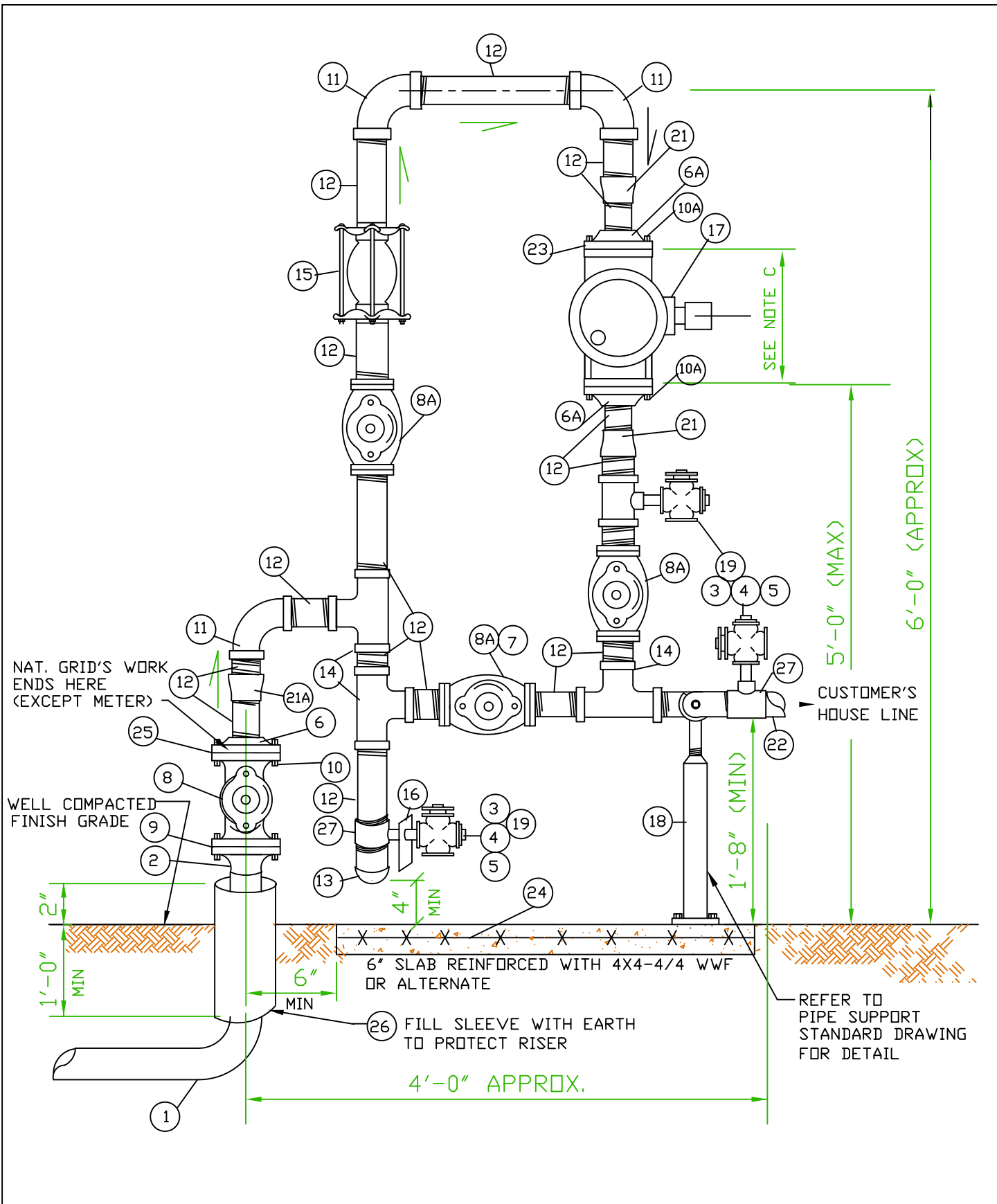
DRAWN: MLoP

NO. **MTRS-6095**

**NOTES**

- A. NAT. GRID SHALL SUPPLY AND INSTALL ITEMS 1 THROUGH 13 INCLUSIVE.
- B. AFTER PURGING A NEW SERVICE AND BEFORE INSTALLING ANY METER, THE LOCKWING METER VALVE (ITEM NO. 3) SHALL BE LOCATED WITH A GAS SNAP LOCK (ITEM ID 136506). SHOULD ONE OF THE METERS REQUIRE SERVICE BEFORE THE OTHERS, THE LOCKWING METER VALVES (ITEM NO. 21) TO THE METERS NOT YET READY FOR SERVICE SHALL BE LOCATED WITH THE TYPE OF LOCKING DEVICES. REFER TO 060009-T1
- C. ALL PIPE AND FITTINGS SHALL BE GALVANIZED.
- D. RISER PIPE AND METER SET SHALL BE LOCATED TO PREVENT PHYSICAL DAMAGE TO THE INSTALLATION BY VEHICLES OR OTHER MECHANICAL DEVICES. REFER TO CUST-5040
- E. MAINTAIN ½" MINIMUM CLEARANCE BETWEEN REGULATOR AND METER CASE OR ANY OTHER FOREIGN STRUCTURE. SWING REGULATOR IF NECESSARY TO OBTAIN CLEARANCE.
- F. **CUSTOMER TO INSTALL BRASS OR ALUMINUM PERMANENT ID TAG ON EACH METER OUTLET PIPING (ITEM NO. 23 OR 24) STAMPED OR ENGRAVED WITH STORE # / APARTMENT # / UNIT OR ADDRESS**
- G. PROPER LENGTH OF NIPPLE (ITEM NO. 8 OR 14) ABOVE UNION (ITEM NO. 9) SHALL BE SELECTED SO THAT THE TOP OF THE METER SHALL NOT EXCEED 6 FEET ABOVE GROUND LEVEL. BOTTOM OF THE METER SHALL NEVER BE LESS THAN 4 INCHES ABOVE GROUND LEVEL.
- H. VENT PIPING SIZE, LENGTH AND NUMBER OF ELBOWS SHALL MEET THE REQUIREMENTS OF CMS-03002.
- I. FOR MORE THAN 3 METERS AND HIGHER LOADS, USE 1 ¼" DIAMETER MANIFOLDS. REFER TO MTRS-6215
- J. THE GAS SERVICE LOCATION TAG SHALL BE INSTALLED PER CUST- 5230
- K. **SEE 020013-CS FOR VENT PIPING LOCATION. IT IS PREFERRED THAT REGULATOR VENTS BE INSTALLED AT A HEIGHT 18 INCHES ABOVE GRADE, HOWEVER, THE MINIMUM ALLOWABLE VENT HEIGHT SHALL BE 12 INCHES ABOVE FINAL GRADE. IN CASES OF KNOWN FLOOD LOCATIONS, THE PREFERRED REGULATOR VENT HEIGHT ABOVE THE FLOOD HEIGHT IS 18" (12" MINIMUM). THE REGULATOR VENT SHALL BE 18" (WHERE PRACTICAL) FROM ANY OPENING WHICH COULD ALLOW VENTED GAS TO ENTER.**
  - \* \* SUPPLIED AND INSTALLED BY THE CUSTOMER
  - X X TO BE SUPPLIED BY FIELD OPERATIONS
  - + AS REQUIRED

24	CUSTOMER HOUSE LINE	+	**	+	**	+	**	+	**	
23	NIPPLE – 1" X AS REQUIRED	2	**	3	**	2	**	3	**	
22	ELBOW - 1" 90 DEGREE	6	**	9	**	6	**	9	**	
21	METERCOCK – LOCKWING – 1"	2	**	3	**	2	**	3	**	
20	NIPPLE – 1" X 3"	4	**	6	**	4	**	6	**	
19	ELBOW – 1 ¼" X 1" – 90 DGREE - REDUCING	1	**	1	**	1	**	1	**	
18	TEE – 1 ¼" X 1 ¼" X 1" - REDUCING	1	**	2	**	1	**	2	**	
17	ROD OR PIPE – ½" OR GAL. PIPE STRAPS	+	**	+	**	+	**	+	**	
16	NIPPLE – 1 ¼" X LENGTH AS REQUIRED	1	**	1	**	1	**	1	**	
15	ELBOW – 1 ¼" – 90 DGREE – GALV .	2	**	2	**	2	**	2	**	
14	NIPPLE – 1 ¼" X 12"	2	**	3	**	2	**	3	**	
13	GAS METER – TEMP . COMPENSATED GAS – 175 OR 250 CLASS	2	X X	3	X X	2	X X	3	X X	
12	METER NUT GASKET – 20 LIGHT	4	9342478	6	9342478	4	9342478	6	9342478	
11	METER NUT – 20 LIGHT	4	9340787	6	9340787	4	9340787	6	9340787	
10	METER SWIVEL – 1" X 20 LIGHT	4	9383109	6	9383109	4	9383109	6	9383109	
9	INSULATED UNION – 1 ¼" – GALV. – THREADED END	1	9341691	1	9341691	1	9341691	1	9341691	
8	NIPPLE – 1 ¼" X 3" – GALV. – THREADED END	1	**	1	**	-	-	-	-	
7	REGULATOR – 1 ¼" –15# MAX INLET – ¼" ORIFICE REGULATOR – 1 ¼" –60# MAX INLET – 3/16" ORIFICE REGULATOR – 1 ¼" –124# MAX INLET – 1/8" ORIFICE	1	9342623 9342206 9383127	1	9342623 9342206 9383127	-	-	-	-	
6	NIPPLE – 1 ¼" X 4" – GALV. – THREADED END	2	9340652	2	9340652	1	**	1	**	
5	GAS SERVICE LOCATION TAG	1	9340255	1	9340255	1	9340255	1	9340255	
4	GAS SNAP LOCK	1	9330915	1	9330915	1	9330915	1	9330915	
3	LOCKWING METERCOCK – 1 ¼" – THREADED END	1	9339609	1	9339609	1	9339609	1	9339609	
2	RISER – 1 ¼" C.T.S. PLASTIC X 1 ¼" I.P.S. STEEL - PREBENT	-	-	1	-	1	9340941	1	9340941	
1	RISER – 1" C.T.S. PLASTIC X 1 ¼" I.P.S. STEEL - PREBENT	1	9340874	1	9340874	1	-	-	-	
		2 METER	3 METER			2 METER		3 METER		
		HIGH PRESSURE (60 PSIG)				LOW PRESSURE (6" W.C.)				
<b>No.</b>	<b>ITEM</b>							<b>NG CODE No.</b>		
<b>BILL OF MATERIAL</b>										



<span style="font-weight: normal; font-size: 1.2em; vertical-align: middle;">LONG ISLAND</span>	<b>LP MAIN / LP METERING FOR 3M125 OR 7M125 VERTICAL - ROTARY GAS METER</b>
---	---

<b>REVISIONS:</b>	REVISD USING SAP ITEM ID #'S	DATE: 7/1/2003	EFFECTIVE DATE: 09/15/2013
		DESIGN: JAL	STD. DWG.
		DRAWN: MLoP	NO. <b>MTRS-6135</b>

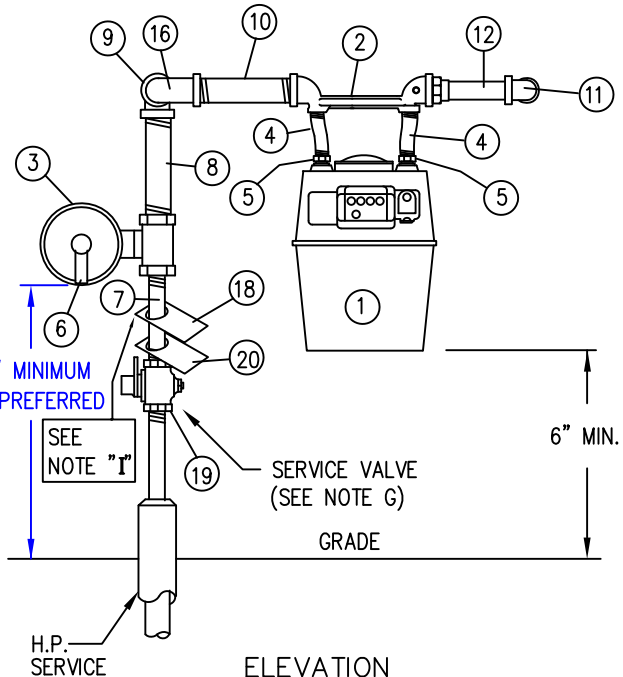
**NOTES**

- A. RISER AND VALVE SHALL BE OF THE SAME SIZE AS THE SERVICE SIZE I.E. FOR A 4" SERVICE USE A 4" RISER AND A 4" VALVE WITH THE APPROPRIATE ITEM SIZES REQUIRED.

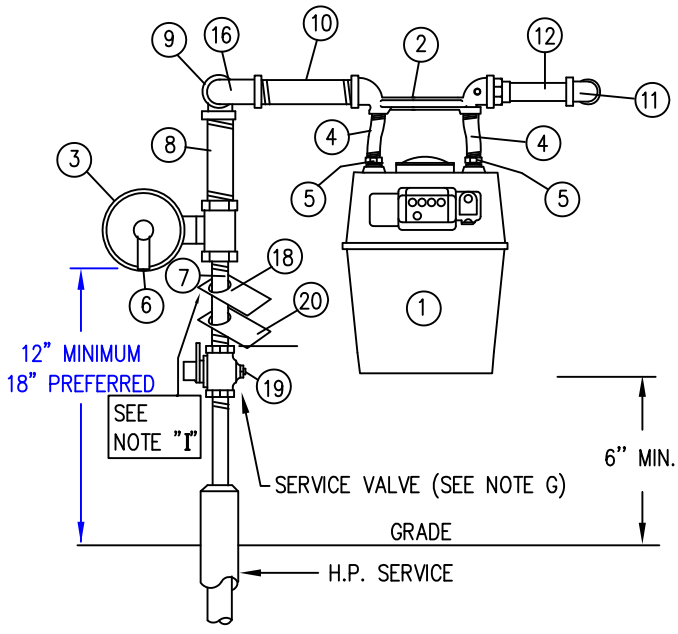
	DESCRIPTION 3 M	SAP ITEM ID	QUANTITY	
			NG	BY CUSTOMER
27	TEE – 3" X 3" X 3/4"- THREADED	X X		3
26	PIPE SLEEVE – 4" – PLASTIC OR EQUIVALENT	NG	1	
25	GASKET RING – 2"	X X		1
24	SLAB REINF. – 4X4 – 4/4 WIRE WELDED FABRIC	X X		1
23	GASKET RING - METER	9341161	2	
22	PIPE – HOUSE LINE	X X		1
21,21A	REDUCER – 3" X 2" - THREADED	X X		3
20	NOT USED			
19	GAS SNAP LOCK	9330915	3	
18	SUPPORT – 2 1/2" PIPE – ADJUSTABLE – TOP SECTION SEE MTRS 6475 BASE 20" - 25" HEIGHT OR BASE 26" - 31" HEIGHT OR BASE 32" – 41" HEIGHT	9339861 9323172 9339886 9339885		1
17	METER – LINE MOUNTED ROTARY – 3M125	X X	1	
16	TAG – SERVICE LOCATION	9340255	1	
15	COUPLING – 3" – COMPANION – DRESSER STYLE 38	XX		1
14	TEE – 3" - THREADED	X X		3
13	CAP – 3" - THREADED	X X		1
12	PIPE – 3" X LENGTH AS REQUIRED - THREADED	X X		=
11	ELBOW – 3" - THREADED	X X		3
10A	BOLT – 5/8" X 2" ASTM A307 GR. B (CAP SCREWS)	9342411	8	
10	BOLT – 5/8" X 2 3/4" A 307 - MACHINE	9339766	8	
9	KIT – 2" – FLANGED - INSULATED	9340992	1	
8A	VALVE – 3" - THREADED	X X		3
8	VALVE – 2" – FLANGED – SEE NOTE A BELOW	9341980	1	
7	LOCKING DEVICE	NG	1	
6,6A	FLANGE – 2" FF. – COMPANION – ANSI CLASS 125	X X		3
5	PLUG – 3/4" - THREADED	X X		3
4	GAS LOCK COCK – 3/4"	X X		3
3	NIPPLE – 3/4" X 3" - THREADED	X X		3
2	FLANGE – 2" – WELD NECK	9341058	1	
1	RISER – 2" – PIPE- -SEE NOTE A ABOVE	* 350+/-		

No.	ITEM	NAT. GRID CODE No.
-----	------	--------------------

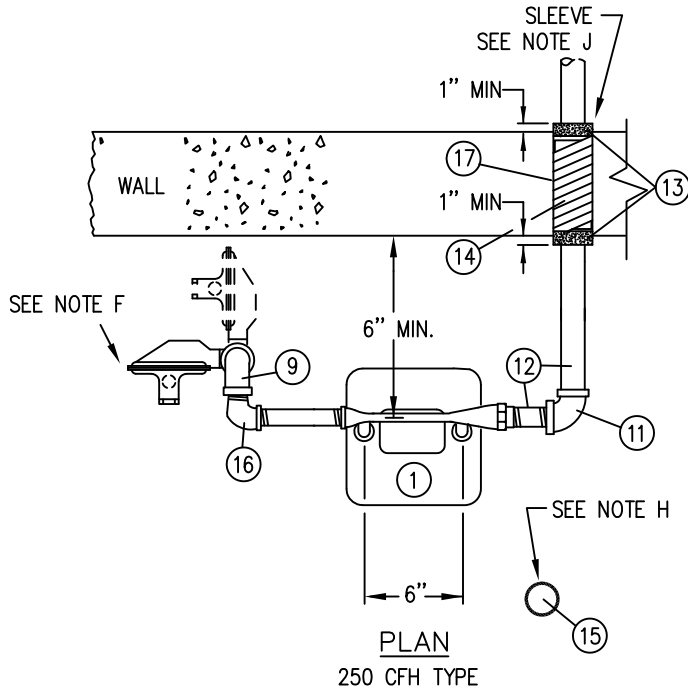
**BILL OF MATERIAL FOR 3M METER**



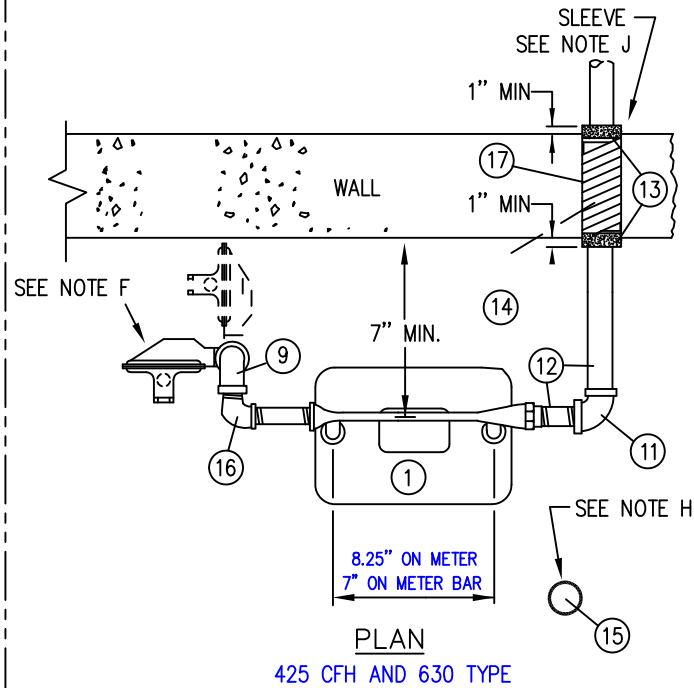
ELEVATION  
250 CFH TYPE



ELEVATION  
425 CFH AND 630 TYPE



PLAN  
250 CFH TYPE



PLAN  
425 CFH AND 630 TYPE



LI-NYC

SINGLE METER AND REGULATOR INSTALLATION  
OUTSIDE SET, 1/2" AND 3/4" DIAMETER  
SERVICES OPERATING AT 15 - 124 PSIG  
250 CFH, 425 CFH AND 630 CFH RANGE

REVISIONS: REVISED USING SAP ITEM ID #'S

DATE: 07/01/2003	EFFECTIVE DATE: 09/15/2013
DESIGN: JTK	STD. DWG. NO. MTRS-6140
DRAWN: GVG	



**NOTES**

- A. KEY REQUIREMENTS FOR THE CONSTRUCTION OF METER HEADERS AND INSTALLATIONS ARE CONTAINED IN NATIONAL GRID'S SPECIFICATIONS CUST-5235 AND THE NATIONAL GRID BLUE BOOK
- B. ADDITIONAL FITTINGS MAY BE REQUIRED TO MAKE THE METER AND REGULATOR INSTALLATION.
- C. NATIONAL GRID SHALL NOT BE RESPONSIBLE FOR FITTING DIMENSIONS OR FOR SCALED DIMENSIONS.
- D. FOR FLOW RATES GREATER THAN 630 CFH SEE MTRS-6185-LI OR MTRS-6120-NYC & MTRS-6121-NYC FOR DUAL REGULATOR CONFIGURATIONS
- E. FOR FLOW RATES GREATER THAN 1000 CFH (60 PSIG SYSTEM) OR 960 CFH (15 PSIG SYSTEM), CONTACT GAS ENGINEERING FOR SPECIAL ENGINEERING METER AND REGULATOR LAYOUT.
- F. **REGULATOR VENT MUST FACE DOWN AND BE EQUIPPED WITH A RAIN AND INSECT RESISTANT SCREEN. FOR NEW CONSTRUCTION OR ALTERATIONS SEE 020013-CS VENT PIPING LOCATION. IT IS PREFERRED THAT REGULATOR VENTS BE INSTALLED AT A HEIGHT 18 INCHES ABOVE GRADE, HOWEVER, THE MINIMUM ALLOWABLE VENT HEIGHT SHALL BE 12 INCHES ABOVE FINAL GRADE. IN CASES OF KNOWN FLOOD LOCATIONS, THE PREFERRED REGULATOR VENT HEIGHT ABOVE THE FLOOD HEIGHT IS 18" (12" MINIMUM). THE REGULATOR VENT SHALL BE 18" (WHERE PRACTICAL) FROM ANY OPENING WHICH COULD ALLOW VENTED GAS TO ENTER.**
- G. SERVICE VALVE MUST BE PAINTED RED (IN NEW YORK CITY ONLY).
- H. WHERE VEHICULAR TRAFFIC IS A CONCERN, INSTALL PROTECTION POST. SEE STANDARD DRAWING MTRS-6060 FOR INSTALLATION REQUIREMENTS.
- I. CPR TAGS ARE REQUIRED IN LONG ISLAND INSTALLATIONS ONLY.
- J. WALL SLEEVES ARE ONLY REQUIRED WHEN SERVICE PENETRATES CONCRETE OR MASONRY WALL. WALL SLEEVES ARE RECOMMENDED, BUT NOT REQUIRED THROUGH STUCCO OR FRAME CONSTRUCTION.
- K. THE CLASS 400 METERS HAVE 30 LIGHT CONNECTIONS IN NEW YORK CITY AND 45 LIGHT CONNECTIONS IN LONG ISLAND. THE CLASS 630 METERS WILL HAVE 45 LIGHT CONNECTIONS IN NYC AND LI.
- L. THE PIPE AND FITTING LISTED BELOW ARE GALVANIZED. BLACK PIPE AND FITTINGS THAT ARE PRIMED AND PAINTED ARE ALSO ACCEPTABLE. **NOTE FOOTNOTES ON METER & SWIVELS B = BLACK, G = GALVANIZED**

METER CAPACITIES	0-250 CFH RANGE	0-425 CFH RANGE	0-630 CFH RANGE
AMERICAN	250	425	630
EQUIMETER/SENSUS	275	415	
ACTARIS/ITRON	250	400	

		250 METER SET	400 & 630 METER SET	SUPPLIED BY			
20	SYSTEM PRESSURE TAG	9346233	9346233	NGG			
19	METER VALVE, LOCK WING GALVANIZED	9339593	9339609	NGG			
18	CPR TAG (LONG ISLAND ONLY)	9340255	9340255	NGG			
17	WALL SLEEVE – PVC PLASTIC PIPE OR STD. WT STEEL PIPE (2" LONGER THAN WALL THICKNESS)	---	---	CUSTOMER			
16	STREET ELBOW 90 DEGREE GALVANIZED	9341192	9341193	CUSTOMER			
15	PROTECTION POST (SEE NOTE H)	---	---	CUSTOMER			
14	YARN, PACKING	---	---	CUSTOMER			
13	FLEXIBLE SEALING COUMPOUND (DUXSEAL)	---	---	CUSTOMER			
12	HOUSE PIPING TO LOAD	---	---	CUSTOMER			
11	ELBOW 90 DEGREES M.I., SIZE OF HOUSE PIPE (GALV.)	1"	1-1/4"	CUSTOMER			
10	NIPPLE, 3" MINIMUM GALVANIZED (LENGTH AS REQUIRED)	1" 9340641	1-1/4" 9340652	CUSTOMER			
9	ELBOW/REDUCING ELBOW 90 DEG M.I. GALVANIZED	1" 9341181	1"X1-1/4" 9341185	CUSTOMER			
8	NIPPLE 1" X 3" MINIMUM (LENGTH AS REQUIRED)	1" 9340641	1" 9340641	CUSTOMER			
7	NIPPLE 3/4" X 4" MINIMUM (LENGTH AS REQUIRED)	3/4" 9340633	3/4" 9340633	CUSTOMER			
6	VENT ASSEMBLY WITH INSECT RESISTANT SCREEN IF REQ'D, 1"	9358640	9358640	NGG			
5	METER CAP/NUT CONNECTION SEE NOTE K	NEW YORK CITY 250 & 400	9340787 <sup>G</sup> 9339519 <sup>B</sup>	1-1/4" 30 LT	9383207 <sup>G</sup> 9339622 <sup>B</sup>	NGG	
		NEW YORK CITY 630 CLASS	---	1-1/4" 45 LT	9339623	NGG	
		LONG ISLAND 250/400/630	9340787	1-1/4" 45 LT	9340788	NGG	
4	METER SWIVEL OFFSET GALV. SEE NOTE K	NEW YORK CITY 250 & 400	1" 9383109 <sup>G</sup> 9342452 <sup>B</sup>	1-1/4" 30 LT	9383108 <sup>G</sup> 9342456 <sup>B</sup>	NGG	
		NEW YORK CITY 630 CLASS	-	-	1-1/4" 45 LT		9386167
		LONG ISLAND 250/400/630	1" 9383109	1-1/4" 45 LT	9342425		
3	REGULATOR, 3/4" X 1" WITH 1/8" ORIFICE: FISHER HSR , ITRON B-42R OR B-31R, SENSUS 143-80-2, AMERICAN 1813B2 OR SR100	9383047	9383047	9383047	NGG		
2	METER BAR, W/INSUL. OUTLET, GALV. AY MCD#6610-GCCD OR EQ METER BAR, W/INSUL. OUTLET, GALV. AY MCD#6640-GCCD OR EQ METER BAR, W/INSUL. OUTLET, BLACK WITH TOP OUTLET	1" X 1" X 1" 9383181	---	---	NGG		
		9339755	1-1/4" X 1-1/4" 9383209	1-1/4" X 1-1/4" 9339756			
1	METER (TEMPERATURE COMPENSATED)	250 CLASS	400 & 630 CLASS				
<b>No.</b>	<b>ITEM</b>			<b>ITEM ID</b>			

**NOTE: IN NYC, ALL MATERIALS AFTER THE SERVICE VALVE WILL BE FURNISHED AND INSTALLED BY THE CUSTOMER EXCEPT FOR THE REGULATOR WHICH IS FURNISHED BY THE COMPANY AND INSTALLED BY THE CUSTOMER. THE METER, SWIVEL AND CAPS (METER NUTS) WILL BE FURNISHED AND INSTALLED BY THE COMPANY. IN LONG ISLAND, NATIONAL GRID WILL INSTALL TO THE METER BAR.**

**NOTES**

	ITEM	ITEM ID	QTY BY NG	QTY BY CUSTOMER
27	TEE – 4" X 4" X 3/4" - THREADED	X X		3
26	SLEEVE – 6" – PIPE – PLASTIC OR EQUIVALENT	NG	1	
25	GASKET RING – 4"	X X		1
24	SLAB REINF. – 4 X 4 – 4/4 WIRE WELDED FABRIC	X X		1
23	GASKET RING - METER	9341162	2	
22	PIPE – HOUSE LINE	X X		1
21A	NOT TO BE USED			
21	REDUCER 4" X 3"	X X		2
20	NOT USED			
19	GAS SNAP LOCK	9330915	3	
18	SUPPORT – 2 1/2" PIPE – ADJUSTABLE – TOP SECTION SEE MTRS 6475 BASE 20" - 25" HEIGHT OR BASE 26" - 31" HEIGHT OR BASE 32" – 41" HEIGHT	9339861 9323172 9339886 9339885		1
17	METER – LINE MOUNTED ROTARY – 7M125	X X	1	
16	TAG – SERVICE LOCATION	9340255	1	
15	COUPLING – 4" – COMPANION – DRESSER STYLE 38	X X		1
14	TEE – 4" - THREADED	X X		3
13	CAP – 4" - THREADED	X X		1
12	PIPE – 4" X LENGTH AS REQUIRED – THREADED ENDS	X X		+
11	ELBOW – 4" - THREADED	X X		3
10A	BOLT – 5/8" X 2" ASTM A307 GR B (CAP SCREWS)	9342411	8	
10	BOLT – 5/8" X 2 3/4" A 307 - MACHINE	9339766	16	
9	KIT – 4" – FLANGED - INSULATED	9341024	1	
8A	VALVE - 4" - THREADED	X X		3
8	VALVE – 4" - FLANGED	9341783	1	
7	LOCKING DEVICE	NG	1	
6A	FLANGE – 3" FF – COMPANION – ANSI CLASS 125	X X		2
6	FLANGE – 4" FF – COMPANION – ANSI CLASS 125	X X		1
5	PLUG – 3/4" - THREADED	X X		3
4	GAS LOCK COCK – 3/4"	X X		3
3	NIPPLE – 3/4" X 3" - THREADED	X X		3
2	FLANGE – 4" – WELD NECK	9340588	1	
1	RISER – 4" - PIPE		+	
<b>No.</b>	<b>ITEM</b>	<b>NAT. GRID'S CODE No.</b>		
<b>BILL OF MATERIAL FOR 7M METER</b>				

## NOTES

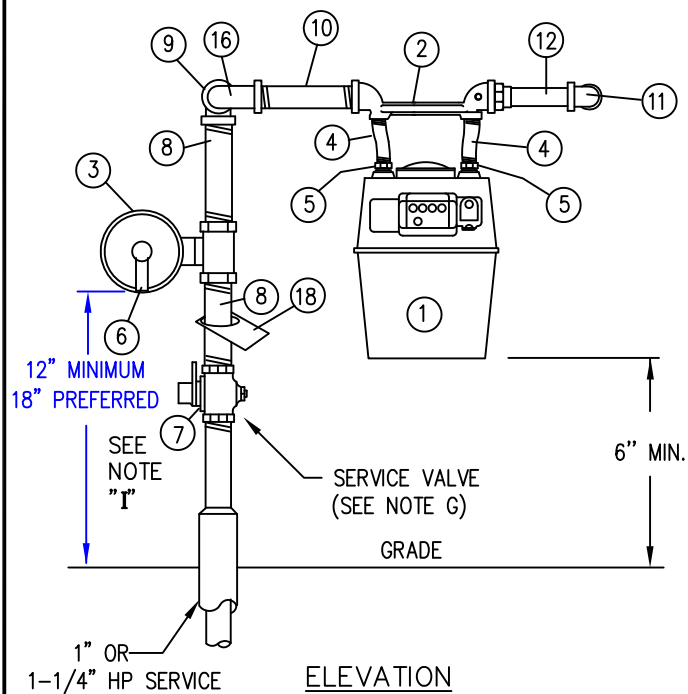
- A. FOR GENERAL NOTES SEE MTRS-6545.
- B. THIS CONSTRUCTION STANDARD SHALL BE USED WHEN AN OUTDOORS 3M OR 7M LOW PRESSURE MAIN & LOW PRESSURE METER SET IS SPECIFIED ON A WORK ORDER. IT SHOULD BE DESIGNED IN ACCORDANCE WITH THE CUSTOMERS TOTAL SERVICE LENGTH AND SIZE AS OUTLINED IN THE DESIGN SECTION.
- C. DISTANCE BETWEEN METER CONNECTION IS 6-3/4" (3M) & 9-1/2" (7M).
- D. CENTERLINE OF PIPING SHALL BE APPROX. 1'-8" FROM WALL.
- E. CINCH ANCHORS OR EQUIVALENT TO BE INSTALLED IN FLOOR FLANGES (ITEMS 29) BY CUSTOMER.
- F. NATIONAL GRID WILL SUPPLY AND INSTALL ALL ITEMS AS LISTED IN M&S CODE COLUMN OF BILL OF MATERIAL.

\* MISSING DIGIT DETERMINED BY TYPE SIZE OR LENGTH OF ITEM

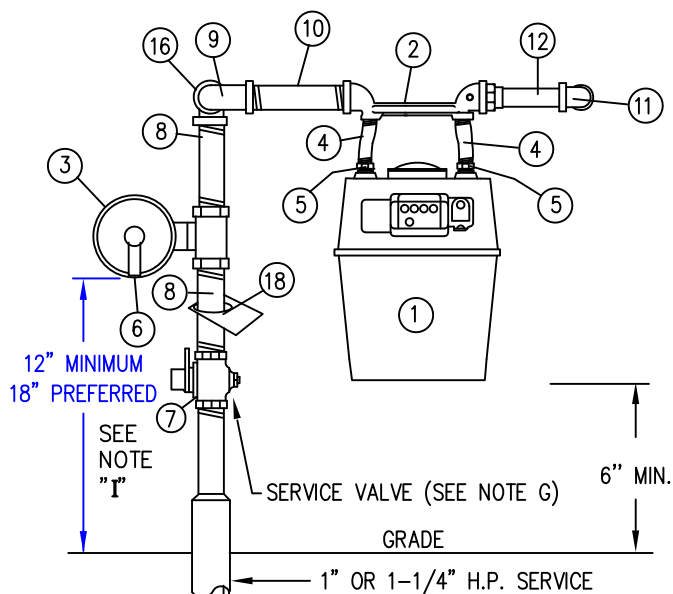
+ AS REQUIRED

X X TO BE SUPPLIED BY F.O.

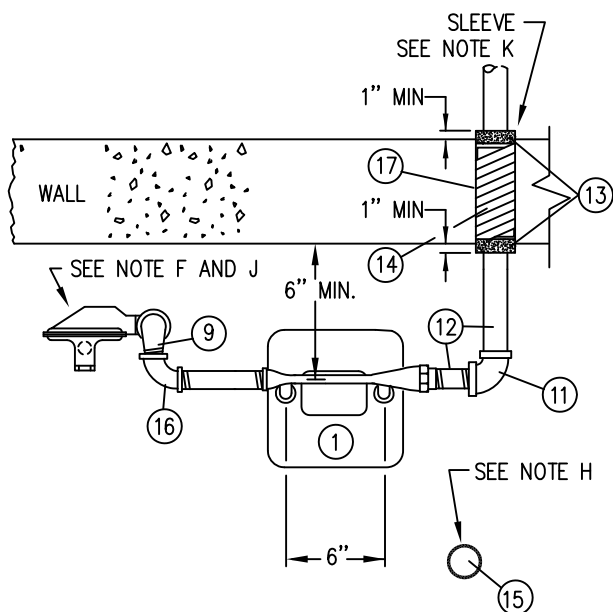
\*\* SUPPLIED AND INSTALLED BY CUSTOMER



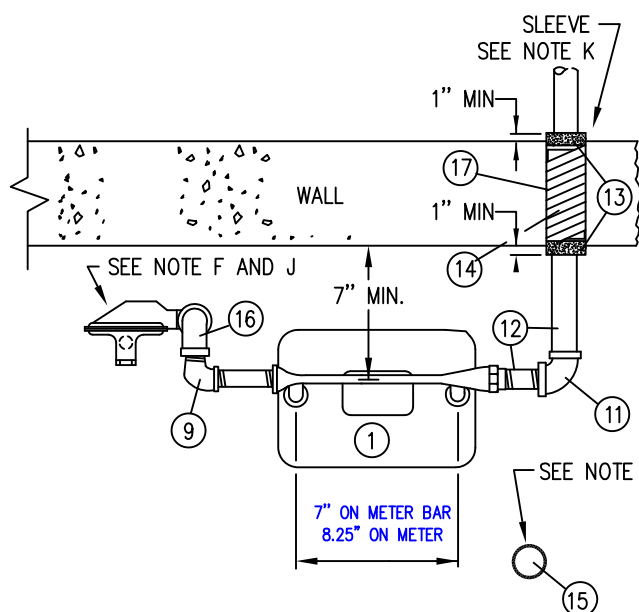
**ELEVATION**  
250 CFH TYPE



**ELEVATION**  
425 CFH AND 630 TYPE



**PLAN**  
250 CFH TYPE



**PLAN**  
425 CFH AND 630 TYPE

**nationalgrid**

LI-NYC

**SINGLE METER AND REGULATOR INSTALLATION  
OUTSIDE SET, 1" AND 1-1/4" DIAMETER SERVICES  
OPERATING AT 15 - 124 PSIG  
0 - 250 CFH, 0 - 425 CFH AND 0 - 630 CFH RANGE**

**REVISIONS: REVISED USING SAP ITEM ID #'S**

DATE: 07/01/2003

EFFECTIVE DATE: 09/15/2013

DESIGN: MJM

STD. DWG.

DRAWN: DiMaio

NO. **MTRS-6142**

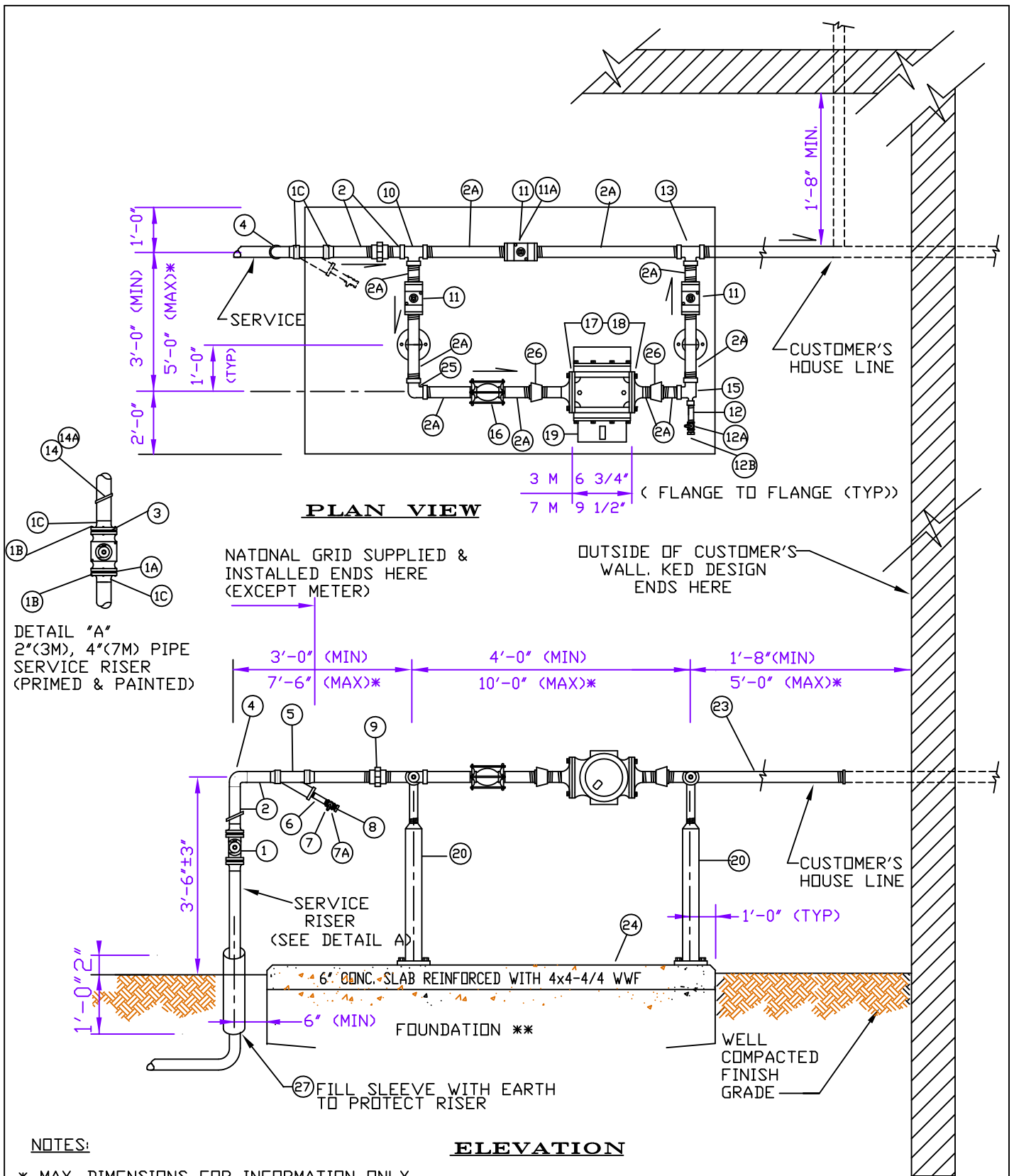
**NOTES:**

- A. KEY REQUIREMENTS FOR THE CONSTRUCTION OF METER HEADERS AND INSTALLATIONS ARE CONTAINED IN NATIONAL GRID'S SPECIFICATIONS CUST-5235.
- B. ADDITIONAL FITTINGS MAY BE REQUIRED TO MAKE THE METER AND REGULATOR INSTALLATION.
- C. NATIONAL GRID SHALL NOT BE RESPONSIBLE FOR FITTING DIMENSIONS OR FOR SCALED DIMENSIONS.
- D. IN NYC, FOR FLOW RATES BETWEEN 630 CFH AND 820 CFH (60# SYSTEM) AND 630 CFH AND 960 CFH (15# SYSTEM) SEE STANDARD DRAWING MTRS-6120 & MTRS-6121.
- E. IN NYC, FOR FLOW RATES GREATER THAN 820 CFH (60 PSIG SYSTEM) OR 960 CFH (15 PSIG SYSTEM) SEE SPECIAL ENGINEERING METER AND REGULATOR LAYOUT.
- F. **REGULATOR VENT MUST FACE DOWN AND BE EQUIPPED WITH A RAIN AND INSECT RESISTANT SCREEN. FOR NEW CONSTRUCTION OR ALTERATIONS SEE 020013-CS VENT PIPING LOCATION. IT IS PREFERRED THAT REGULATOR VENTS BE INSTALLED AT A HEIGHT 18 INCHES ABOVE GRADE, HOWEVER, THE MINIMUM ALLOWABLE VENT HEIGHT SHALL BE 12 INCHES ABOVE FINAL GRADE. IN CASES OF KNOWN FLOOD LOCATIONS, THE PREFERRED REGULATOR VENT HEIGHT ABOVE THE FLOOD HEIGHT IS 18" (12" MINIMUM). THE REGULATOR VENT SHALL BE 18" (WHERE PRACTICAL) FROM ANY OPENING WHICH COULD ALLOW VENTED GAS TO ENTER.**
- G. SERVICE VALVE MUST BE PAINTED RED (IN NEW YORK CITY ONLY).
- H. WHERE VEHICULAR TRAFFIC IS A CONCERN, INSTALL PROTECTION POST. SEE STANDARD DRAWING MTRS-6060 FOR INSTALLATION REQUIREMENTS.
- I. CPR TAGS ARE REQUIRED IN LONG ISLAND INSTALLATIONS ONLY.
- J. WARNING ON 99 PSIG AND 124 PSIG SERVICES, THE ORIFICE MUST 1/8".
- K. WALL SLEEVES ARE ONLY REQUIRED WHEN SERVICE PENETRATES CONCRETE OR MASONRY WALL. WALL SLEEVES ARE RECOMMENDED. BUT NOT REQUIRED THROUGH STUCCO OR FRAME CONSTRUCTION.
- L. THE CLASS 400 METERS HAVE 30 LIGHT CONNECTIONS IN NEW YORK CITY AND 45 LIGHT CONNECTIONS IN LONG ISLAND. THE CLASS 630 METER WILL HAVE 45 LIGHT CONNECTIONS IN LI AND NYC. **FOOTNOTE B = BLACK AND G = GALVANIZED**

METER CAPACITIES	0 - 250 CFH RANGE	0 - 425 CFH RANGE	0 - 630 CFH RANGE
AMERICAN / ELSTER	AL -250	AL-425	AC-630
ROCKWELL / EQUIMETER/SENSUS	275	415	
SPRAGUE / SCHLUMBERGER/ITRON	250	400	

		250 METER METER SET		400 & 630 METER SET			
18	CPR TAG (LONG ISLAND ONLY)	9340255		9340255		NGG	
17	WALL SLEEVE – PVC PLASTIC PIPE OR STD. WT STEEL PIPE (2" LONGER THAN WALL THICKNESS)	-----		-----		CONTRACTOR	
16	ELBOW 90 DEGREE GALVANIZED	1"	9341181	1-1/4"	9341182	CONTRACTOR	
15	PROTECTION POST (SEE NOTE H)	-----		-----		CONTRACTOR	
14	YARN, PACKING	-----		-----		CONTRACTOR	
13	FLEXIBLE SEALING COMPOUND (DUXSEAL)	-----		-----		CONTRACTOR	
12	HOUSE PIPING TO LOAD	-----		-----		CONTRACTOR	
11	ELBOW ,90 M.I. SIZE OF HOUSE PIPE (GALV.)	1"		1 - 1/4"		CONTRACTOR	
10	NIPPLE 3" MINIMUM GALVANIZED (LENGTH AS REQUIRED)	1"	9340641	1 - 1/4"	9340652	CONTRACTOR	
9	STREET ELBOW, / REDUCING STREET ELBOW 90 M.I. GALVANIZED	1" X 1 - 1/4"	9341199	1 - 1/4"	9341193	CONTRACTOR	
8	NIPPLE 4" MINIMUM GALVANIZED (LENGTH AS REQUIRED)	1 - 1/4"	9340652	1 - 1/4"	9340652	CONTRACTOR	
7	METER VALVE, LOCK WING GALVANIZED	1 - 1/4"	9339609	1 - 1/4"	9339609	CONTRACTOR	
6	VENT ASSEMBLY WITH INSECT RESISTANT SCREEN, IF REQUIRED, 1"	9358640		9358640		NGG	
5	METER CAP / NUT CONNECTION SEE NOTE L	NEW YORK CITY 250 & 400	9340787 <sup>G</sup> 9339519 <sup>B</sup>	1 - 1 / 4" 20LT	9383207 <sup>G</sup> 1-1/4" 30 LT 9339622 <sup>B</sup> 1-1/4" 30 LT	NGG	
		NEW YORK CITY 630 CLASS	-	-	9339623 1-1/4" 45 LT <sup>B</sup> 9340788 1-1/4" 45 LT <sup>G</sup>		
		LONG ISLAND (GALV.)	9340787		1 - 1 / 4" 45 LT		9340788
4	METER, OFFSET SWIVEL SEE NOTE L	NEW YORK CITY 250 & 400	1" 20 LT	9383109 <sup>B</sup> 9342452 <sup>G</sup>	1-1/4" 30 LT.	9342456 <sup>B</sup> 9383108 <sup>G</sup>	NGG
		NEW YORK 630 CLASS	-	-	1-1/4" 45 LT.	9386167 <sup>B</sup> 9342425 <sup>G</sup>	
		LONG ISLAND (GALV.)	1" 20 LT.	9383109	1-1/4" 45 LT.	9342425	
3	REGULATOR, 1 -1/4" ITRON – 42R / B 31 R, SENSUS 143 – 80 –2, AMERICAN 1813 OR SR-100 FOR 15 PSIG SERVICE – REGULATOR, 1 – 1/4" WITH 1/4" ORIFICE FOR 60 PSIG SERVICE- REGULATOR, 1 – 1/4" WITH 3 /16" ORIFICE FOR 99 / 124 PSIG SERVICE – REGULATOR, 1 – 1/4" WITH 1/8" ORIFICE	9342623 9342206 9383127		9342623 9342206 9383127		NGG NGG NGG	
2	METER BAR, W / INSUL. OUTLET, GALV. AY MCD#6610-GCCD OR EQ. METER BAR, W / INSUL. OUTLET, GALV. AY MCD#6640-GCCD OR EQ. METER BAR, W/INSULATED OUTLET, BLACK WITH TOP OUTLET	1" X 1" X1" 9383181 ----- -----		----- 1-1/4" X 1-1/4" 9383209 1-1/4" X 1-1/4" 9339756		NGG	
1	METER (TEMPERATURE COMPENSATED)	0-250		0-425 & 0-630		NGG	
No.	ITEM	250 METER SET NGG CODE NO.		400 & 630 METER SET NGG CODE NO.		NGG CODE No.	

**NOTE: IN NYC, ALL MATERIALS AFTER THE SERVICE VALVE WILL BE FURNISHED AND INSTALLED BY THE CUSTOMER EXCEPT FOR THE REGULATOR WHICH IS FURNISHED BY THE COMPANY AND INSTALLED BY THE CUSTOMER. THE METER, SWIVEL AND CAPS (METER NUTS) WILL BE FURNISHED AND INSTALLED BY THE COMPANY. IN LONG ISLAND,NATIONAL GRID WILL INSTALL UP TO THE METER BAR.**



**NOTES:**

- \* MAX. DIMENSIONS FOR INFORMATION ONLY
- \*\* SEE GENERAL NOTES

**nationalgrid**

LONG ISLAND

**LP MAIN / LP METERING  
FOR 3M125, OR 7M125  
HORIZONTAL - ROTARY GAS METER  
OUTSIDE LOCATIONS**

**KEY CHANGES:** REVISED USING SAP ITEM ID #'S

DATE: 7/1/2003

EFFECTIVE DATE: 09/15/2013

DESIGN: GJK

STD. DWG.

DRAWN: HF

NO. **MTRS-6145**

**NOTES**

- A. SEE GENERAL NOTES MTRS- 6545  
 B. ALL SCREW TYPE PIPE FITTINGS TO BE HOT DIPPED GALVANIZED  
 C. ALL FITTINGS SHALL BE MALLEABLE IRON CLASS 150, ANSI B 16.3  
 D. CINCH ANCHORS TO BE INSTALLED IN FLOOR FLANGES (ITEM 20) BY CUSTOMER  
 E. FOR UNDERGROUND CUSTOMER'S HOUSE PIPING REFER TO DESIGN SECTION  
 F. FOR VEHICULAR DAMAGE PROTECTION SEE MTRS – 6060  
 G. A METER SHALL NEVER BE INSTALLED LOWER THAN EITHER SIDE OF PIPE RUNS  
 H. NATIONAL GRID WILL SUPPLY AND INSTALL ITEMS 1 THRU 8 (EXCEPT 2A), 11A,14, 17A THRU 19 AND 27

**LEGEND**

X X – SUPPLIED BY CUSTOMER

\*\* – TO BE SUPPLIED BY F.O.

+ AS REQUIRED

27	SLEEVE – 4" PIPE (PLASTIC OR EQUIVALENT)	1	NATIONAL GRID
26	REDUCER 3" X 2"	2	X X
25	ELBOW – 90 3"	1	X X
24	SLAB REINF 4X 4 – 4/4 WWF	1	X X
23	PIPE HOUSE LINE	+	X X
22	NOT USED		
21	NOT USED		
20	SADDLE – PIPE STANCHION – ADJUSTABLE SEE MTRS 6475	2	NATIONAL GRID
19	METER LINE MOUNTED ROTARY 3M 125	1	**
18	GASKET RING- METER	2	9341161
17A	BOLT, 5/8 – 11 X 2 ASTM A 307 GR. B	8	9342411
17	FLANGE – COMPANION 2"FF, ANSI CLASS 125	2	X X
16	COUPLING – COMPRESSION 3" DRESSER STYLE 38	1	X X
15	TEE 3 X 3 3/4 X 3	1	X X
14A	SELF LOCKING NYLON STRAP 14"	1	9325971
14	TAG – GAS SERVICE LOCATION	1	9340255
13	TEE 3" X 3" X 3"	1	X X
12B	PLUG, SOLID 3/4" NPT	1	X X
12A	COCK, LOCKWING 3/4"	1	X X
12	NIPPLE, 3/4" X 3" LONG	1	X X
11A	LOCKING DEVICE	1	NATIONAL GRID
11	VALVE 3"	3	X X
10	TEE 2" X 3" X 3"	1	X X
9	UNION 2"	1	X X
8	PLUG, SOLID 1/2" NPT	1	9342549
7A	GAS SNAP LOCK	1	9330915
7	COCK, LOCKWING 1/2"	1	NON STOCK
6	NIPPLE, 1/2" X 3" LONG	1	9340621
5	STRAINER – CAST IRON, FLANGED END "Y" 100 MESH SCREEN W/BOLTS	1 1	9340158 9340158
4	ELBOW 2" 90	1	9341213
3	GASKET RING 2"	3	9341161
2A	PIPE- 3"	+	X X
2	PIPE – 2"	+	9340729
1C	FLANGE 2" WELDED NECK	4	9341058
1B	BOLTS MACHINE 5/8" X 2 3/4" A 307	8	9339766
1A	GASKET – FLANGED INSULATED INSULATED , 2"	1	9340992
1	VALVE – FLANGE 2"	1	9341980

No.	ITEM		NG CODE No.
-----	------	--	-------------

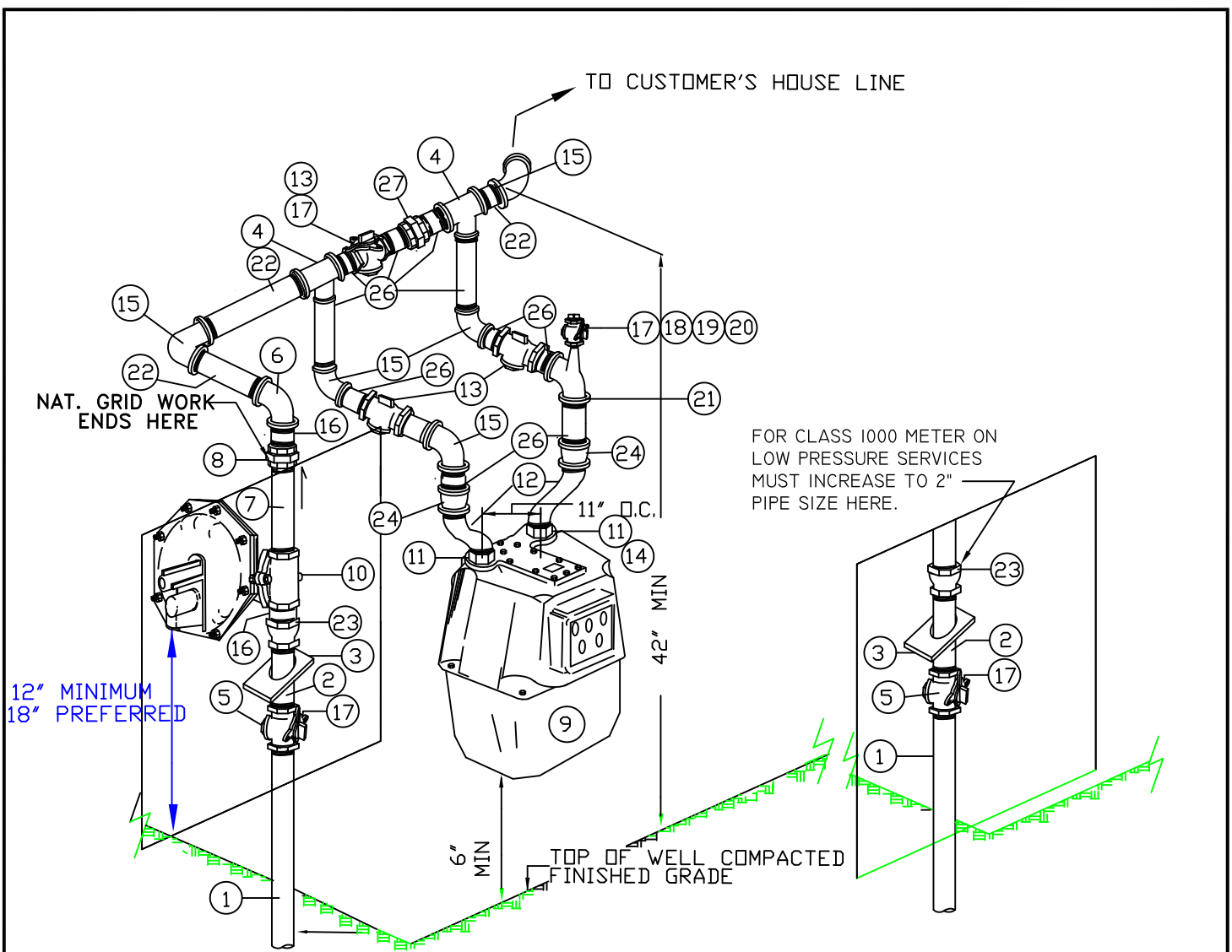
**BILL OF MATERIAL**

**NOTES**

- A. SEE GENERAL NOTES MTRS-6545  
 B. ALL SCREW TYPE PIPE FITTINGS TO BE HOT DIPPED GALVANIZED  
 C. ALL FITTINGS SHALL BE MALLEABLE IRON CLASS 150, ANSI B 16.3  
 D. CINCH ANCHORS TO BE INSTALLED IN FLOOR FLANGES (ITEM 20) BY CUSTOMER  
 E. FOR UNDERGROUND CUSTOMER'S HOUSE PIPING REFER TO DESIGN SECTION  
 F. FOR VEHICULAR DAMAGE PROTECTION SEE APPROVED KEYSpan VEHICLE PROTECTOPN POST DRAWING.  
 G. A METER SHALL NEVER BE INSTALLED LOWER THAN EITHER SIDE OF PIPE RUNS  
 H. NATIONAL GRID WILL SUPPLY AND INSTALL ITEMS 1 THRU 8 (EXCEPT 2A), 11A ,14, 14A, 17A THRU 19 AND 27

27	SLEEVE – 6" PIPE (PLASTIC OR EQUIVALENT)	1	NATIONAL GRID
26	REDUCER 4" X 3"	2	X X
25	ELBOW – 90' 4"	1	X X
24	SLAB REINF 4X4 – 4/4 WWF	1	X X
23	PIPE – HOUSE LINE	+	X X
22	NOT USED		
21	NOT USED		
20	SADDLE – PIPE STANCHION - ADJUSTABLE	2	NG
19	METER LINE MOUNTED ROTARY 7M 125	1	**
18	GASKET RING - METER	2	9341162
17A	BOLTS, 5/8 – 11X2 ASTM A 307 GR B	8	9342411
17	FLANGE – COMPANION 3"FF. ANSI CLASS 125	2	X X
16	COUPLING- COMPRESSION – 4" DRESSER STYLE 38	1	X X
15	TEE 4" X 3/4" X 4"	1	X X
14A	SELF LOCKING NYLON STRIP 14"	1	9325971
14	TAG – GAS SERVICE LOCATION	1	9340255
13	TEE 4"	1	X X
12B	PLUG, SOLID 3/ 4" NPT	1	X X
12A	COCK, LOCKWING 3/4"	1	X X
12	NIPPLE, 3/ 4" X 3" LONG	1	X X
11A	LOCKING DEVICE	1	NG
11	VALVE – 4"	3	X X
10	TEE 4"	1	X X
9	UNION 4"	1	X X
8	PLUG, SOLID 1 1/4" NPT	1	9340914
7A	GAS SNAP LOCK	1	9330915
7	COCK, LOCKWING 1 1/4"	1	9339609
6	NIPPLE, 1 1/4" X 3" LONG	1	9340650
5	STRAINER – CAST IRON, FLANGED END "Y" 100 MESH SCREEN W/BOLTS	1	9340157
4	ELBOW – 90 – WELD 4"	1	9341207
3	GASKET RING 4"	3	9341160
2, 2A	PIPE – 4"	+	9340906
1C	FLANGE 4"	4	9340588
1B	BOLTS MACHINE 5/8" X 3" A 307	16	9339769
1A	FLANGE – INSULATED 4"	1	9341024
1	VALVE – 4"	1	9341783
<b>No.</b>	<b>ITEM</b>		<b>NG CODE No.</b>
<b>BILL OF MATERIAL</b>			





1-1/4", 1-1/2" OR 2" RISERS

**HIGH PRESSURE SERVICE**  
REGULATOR SELECTION - SEE NOTE "K"

**LOW PRESSURE SERVICE**  
SEE NOTE "S"

**FIGURE 1 - WITH BYPASS**

INLET PRESSURE	REGULATOR	ORIFICE REQUIREMENTS
30/60 PSIG INLET	2" FISHER CS-806IR ITEM ID 9386776 OR 1-1/4" B-31R ITEM ID 9342206 2" S-302/B34SR ITEM ID 9342660 OR 2" B34-IMRV ITEM ID 9342684 OR 1-1/2" S302/B34SR ITEM ID 9383176	1/2" (STANDARD ORIFICE FOR ITEM ID - 100 PSIG) 3/16" (STANDARD ORIFICE FOR ITEM ID) 7/32"x1/4" (STANDARD ORIFICE FOR ITEM ID) 1/2" (STANDARD ORIFICE FOR ITEM ID) CHANGE ORIFICE TO 7/32"x1/4" ITEM ID 9383242 FOR S-302 AND 9324363 FOR ACTARIS B34SR
99/124 PSIG INLET	2" FISHER CS-806IR ITEM ID 9386776 OR 1-1/4" B31R/B42R ITEM ID 9383127 AMER. 1813B2, SR-100 2" S302/B34SR ITEM ID 9342660	3/8" ( ITEM ID 9386786 FOR 124 PSIG INLETS) 1/8" (STANDARD ORIFICE FOR ITEM ID) CHANGE ORIFICE TO 5/32"x3/16" ITEM ID 357178? FOR S-302 AND 9324362 FOR ACTARIS B34SR

**nationalgrid**

LONG ISLAND

OUTDOOR METER SET  
CLASS 750/800/1000  
LP-124 PSIG SERVICES  
LOW PRESSURE & 1/2 PSIG OUTLETS

REVISIONS: REVISED USING SAP ITEM ID #'S

DATE: 04/29/2004

EFFECTIVE DATE: 07/15/2013

DESIGN: PAUL GUGLIOTTA

STD. DWG.

DRAWN: PAUL GUGLIOTTA

NO.

**MTRS-6185**

NO.	ITEM	1 ¼" SERVICE	QTY	1 ½" SERVICE	QTY	2" SERVICE	QTY	SUPPLIED BY
27	UNION – 1-1/4" GALVANIZED NON-INSUL.		1		1		1	CUSTOMER
26	NIPPLE 1-1/4" X 2 ½" LONG LENGTH, GALV, SCH 40		9		9		9	CUSTOMER
25	ITEM DELETED		0		0		0	CUSTOMER
24	ITEM NOT NEEDED FOR CLASS 800 METER		0		0		0	CUSTOMER
23	REDUCER 1 ¼" X 2" GALV. (FOR 1 ¼" SERVICES THAT USE 2" REGULATOR)	9342614	1		0		0	NAT. GRID
22	NIPPLE – 1-1/4" X AS REQUIRED LENGTH, GALV, SCH 40		2		2		2	CUSTOMER
21	TEE – 1-1/4" X ¾" X 1-1/4" – HEEL – M.I. GALV., THREADED		1		1		1	CUSTOMER
20	VALVE LOCKWING, MUELLER TAMPER-PROOF H-11118 – LOCK CLOSED ¾"		1		1		1	CUSTOMER
19	NIPPLE ¾" X 4" GALV. SCH. 40		1		1		1	CUSTOMER
18	PLUG – ¾" GALV.		1		1		1	CUSTOMER
17	LOCK		3		3		3	NAT. GRID
16	NIPPLE 1 ¼". 1 ½" OR 2" X 3" LONG, GALV. SCH. 40		1		1		1	CUSTOMER
15	ELBOW 1-1/4" GALV. 90 DEGREE		5		5		5	CUSTOMER
14	RUBBER WASHER FOR METER SWIVEL	9342480	2	9342480	2	9342480	2	NAT. GRID
13	METER VALVE - LOCK WING – 1-1/4"	9339609	3	9339609	3	9339609	3	CUSTOMER
12	METER SWIVEL 1 ¼" X 45 LIGHT	9342425	2	9342425	2	9342425	2	NAT. GRID
11	METER NUT GALV. 45 LT	9340788	2	9340788	2	9340788	2	NAT. GRID
10	A. REGULATOR 2" SCR'D FISHER S302/ITRON B34SR (5"-9" OUTLET SPRING RANGE) OR B. REGULATOR 1 ½" SCR'D FISHER S302 /ITRON B34SR (5"-9" OUTLET SPRING RANGE) SEE NOTE "K" C. REGULATOR 1 ¼" SCR'D FISHER HSR/ITRON B42 1/8" ORIF. OR EQ. FOR 99 AND 124 PSIG SERVICES ONLY D. REGULATOR 1 ¼" SCR'D ITRON B31R WITH 3/16" ORIFICE FOR 60 PSIG MAX E. FISHER CS-806 IR 2" THREADED	SEE TABLE ON PG 1	1	SEE TABLE ON PG 1	1	SEE TABLE ON PG 1	1	NAT. GRID NAT. GRID NAT. GRID
9	METER CLASS 800		1		1		1	NAT. GRID
8	UNION – INSULTAING GALV. 1-1/4", 1 ½" OR 2"	9341685	1	9341686	1	9341687	1	NAT. GRID
7	NIPPLE – LENGTH AS REQUIRED X REGULATOR SIZE OR RISER SIZE FOR LOW PRESSURE SERVICES		1		1		1	NAT. GRID
6	ELBOW 1 – ½" X 1-1/4" GALV. 90 DEGREE, THREADED FOR 1 – ½" REGULATORS ELBOW 2" X 1-1/4" GALV. 90 DEGREE, THREADED – FOR 2" REGULATORS ELBOW 1 – ¼" GALV. 90 DEGREE, THREADED FOR 1 ¼" REGULATORS		- - 1		1 - -		- 1 -	CUSTOMER
5	PLUG VALVE – SERVICE SIZE 1-¼", 1-½" OR 2" THREADED ENDS. ALTERNATE: 2" FLANGED PLUG VALVE (ITEM 382214 – SEE NOTE R)	9339609	1	9341952	1	9341953 OR 9341980	1 1	NAT. GRID NAT. GRID
4	TEE 1-1/4" X 1-1/4" GALV. SCREWED ENDS		2		2		2	CUSTOMER
3	SERVICE LOCATION TAG – LONG ISLAND INSTALLATIONS ONLY	9340255	1	9340255	1	9340255	1	NAT. GRID
2	NIPPLE – SERVICE SIZE X LENGTH AS REQUIRED, GALV. SCH. 40		1		3		3	NAT. GRID
1	RISER	1 ¼"	1	1 ½"	1	2"	1	NAT. GRID
<b>No.</b>	<b>ITEM</b>	<b>NAT. GRID CODE No.</b>						

**BILL OF MATERIAL FOR CLASS 800 METERS**

NO.	ITEM	1 1/4" SERVICE	QTY	1 1/2" SERVICE	QTY	2" SERVICE	QTY	SUPPLIED BY
27	UNION 2" – GALVANIZED – NON-NSULATING		1		1		1	CUSTOMER
26	NIPPLE 2" X 2 1/2" LONG LENGTH, GALV, SCH 40		11		11		11	CUSTOMER
25	ITEM DELETED		0		0		0	CUSTOMER
24	REDUCER 1 1/4" X 2" GALVANIZED		2		2		2	CUSTOMER
23	REDUCER 1 1/4" X 2" GALV. (FOR 1 1/4" SERVICES THAT USE 2" REGULATOR)	9342614	1		0		0	NAT. GRID
22	NIPPLE – 2" X AS REQUIRED LENGTH, GALV, SCH 40		2		2		2	CUSTOMER
21	TEE – 2" X 3/4" X 2" – HEEL – M.I. GALV., THREADED		1		1		1	CUSTOMER
20	VALVE LOCKWING, MUELLER TAMPER-PROOF H-11118 – LOCK CLOSED 3/4"		1		1		1	CUSTOMER
19	NIPPLE 3/4" X 4" GALV. SCH. 40		1		1		1	CUSTOMER
18	PLUG – 3/4" GALV.		1		1		1	CUSTOMER
17	LOCK		3		3		3	NAT. GRID
16	NIPPLE 1 1/4". 1 1/2" OR 2" X 3" LONG, GALV. SCH. 40		1		1		1	CUSTOMER
15	ELBOW 2" GALV. 90 DEGREE		5		5		5	CUSTOMER
14	RUBBER WASHER FOR METER SWIVEL	9342480	2	9342480	2	9342480	2	NAT. GRID
13	METER VALVE - LOCK WING - 2"	9339610	3	9339610	3	9339610	3	CUSTOMER
12	METER SWIVEL 1 1/4" X 45 LIGHT	9342425	2	9342425	2	9342425	2	NAT. GRID
11	METER NUT GALV. 45 LT	9340788	2	9340788	2	9340788	2	NAT. GRID
10	A. REGULATOR 2" SCR'D FISHER S302/ITRON B34SR (5"-9" OUTLET SPRING RANGE) OR CS-806IR 2" B. REGULATOR 1 1/2" SCR'D FISHER S302/ITRON B34SR (5"-9" OUTLET SPRING RANGE) SEE NOTE "K" C. REGULATOR 1 1/4" SCR'D FISHER S102K/ITRON B42 1/8" ORIF. OR EQ. FOR 99 AND 124 PSIG SERVICES ONLY D. REGULATOR 1 1/4" SCR'D ITRON B31R WITH 3/16" ORIFICE FOR 60 PSIG MAX	SEE TABLE ON PG 1	1	SEE TABLE ON PG 1	1	SEE TABLE ON PG 1	1	NAT. GRID NAT. GRID NAT. GRID
9	METER CLASS 1000		1		1		1	NAT. GRID
8	UNION – INSULTAING GALV. 1-1/4" ,1 1/2" OR 2"	9341685	1	9341686	1	9341687	1	NAT. GRID
7	NIPPLE – LENGTH AS REQUIRED X REGULATOR SIZE OR RISER SIZE X 2" FOR LOW PRESSURE SERVICES		1		1		1	NAT. GRID
6	ELBOW – 1 – 1/2" X 2" GALV. 90 DEGREE, THREADED FOR 1 – 1/2" REGULATORS ELBOW – 2" GALV. 90 DEGREE, THREADED – FOR 2" AND L.P. SERVICES ELBOW – 1 – 1/4" X 2" GALV. 90 DEGREE, THREADED FOR 1 1/4" REGULATORS		- - 1		1 - -		- 1 -	CUSTOMER
5	PLUG VALVE – SERVICE SIZE 1-1/4", 1-1/2" OR 2" THREADED ENDS. ALTERNATE: 2" FLANGED PLUG VALVE (ITEM 382214 – SEE NOTE R)	9339609	1	9341952	1	9341953 OR 9341980	1 1	NAT. GRID NAT. GRID
4	TEE 2" X 2" GALV. SCREWED ENDS		2		2		2	CUSTOMER
3	SERVICE LOCATION TAG – LONG ISLAND INSTALLATIONS ONLY	9340255	1	9340255	1	9340255	1	NAT. GRID
2	NIPPLE – SERVICE SIZE X LENGTH AS REQUIRED, GALV. SCH. 40		1		3		3	NAT. GRID
1	RISER	1 1/4"	1	1 1/2"	1	2"	1	NAT. GRID
<b>No.</b>	<b>ITEM</b>	<b>NAT. GRID CODE No.</b>						

**BILL OF MATERIAL FOR CLASS 1000 METERS**

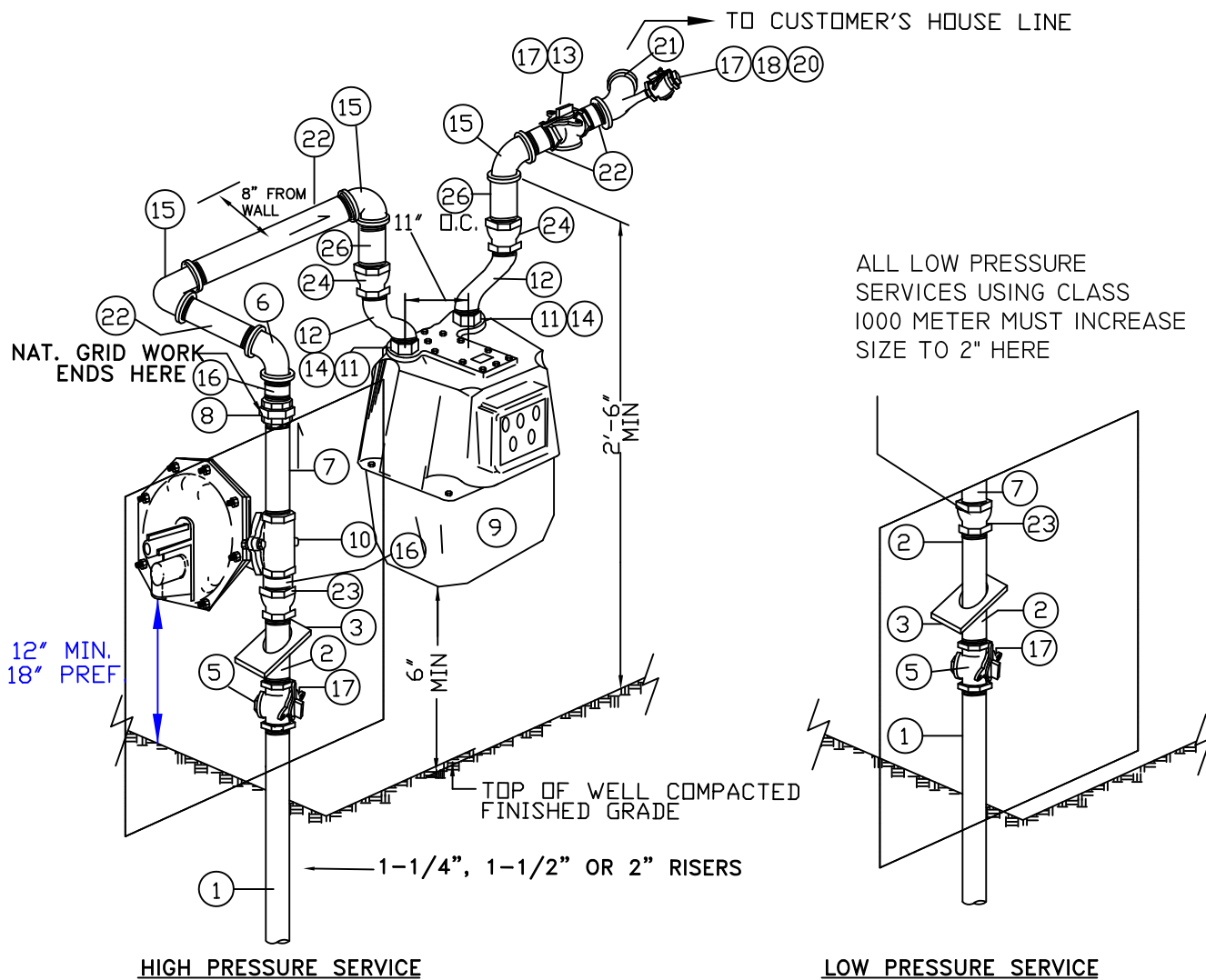


FIGURE 2 – NO BYPASS

REGULATOR SELECTION – SEE NOTE "K"

INLET PRESSURE	REGULATOR	ORIFICE REQUIREMENTS
30/60 PSIG INLET	1-1/4" B-31R ITEM ID 9342206 2" S-302/B34SR ITEM ID 9342660 OR 2" B34-IMRV ITEM ID 9342684 OR 1-1/2" S302/B34SR ITEM ID 9383176  2" FISHER CS806IR ITEM ID 9386776	3/16" (STANDARD ORIFICE FOR ITEM ID) 7/32"x1/4" (STANDARD ORIFICE FOR ITEM ID) 1/2" (STANDARD ORIFICE FOR ITEM ID) CHANGE ORIFICE TO 7/32"x1/4" ITEM ID 9383242 FOR S-302 AND 9324363 FOR ACTARIS B34SR 1/12" (100 PSIG MAX)
99/124 PSIG INLET	1-1/4" B31R/B42 ITEM ID 9383127 2" S302/B34SR ITEM ID 9342660  2" FISHER CS806IR ITEM ID 9342206	1/8" (STANDARD ORIFICE FOR ITEM ID) CHANGE ORIFICE TO 5/32"x3/16" ITEM ID 357178? FOR S-302 AND 9324362 FOR ACTARIS B34SR FOR 124 PSIG USE 3/8" ORIF ITEM 9386786

NO.	ITEM	1 ¼" SERVICE	QTY	1 ½" SERVICE	QTY	2" SERVICE	QTY	SUPPLIED BY
26	NIPPLE 1-1/4" X 2 ½" LONG LENGTH, GALV, SCH 40		2		2		2	CUSTOMER
25	ITEM DELETED		0		0		0	CUSTOMER
24	COUPLING 1 ¼" GALVANIZED		2		2		2	CUSTOMER
23	REDUCER 1 ¼" X 2" GALV. (FOR 1 ¼" SERVICES THAT USE 2" REGULATOR)	9342614	1		0		0	NAT. GRID
22	NIPPLE – 1-1/4" X AS REQUIRED LENGTH,GALV, SCH 40		4		4		4	CUSTOMER
21	TEE – 1-1/4" X ¾" X 1-1/4" – HEEL – M.I. GALV., THREADED		1		1		1	CUSTOMER
20	VALVE LOCKWING, MUELLER TAMPER-PROOF H-11118 – LOCK CLOSED ¾"		1		1		1	CUSTOMER
19	NIPPLE ¾" X 4" GALV. SCH. 40		1		1		1	CUSTOMER
18	PLUG – ¾" GALV.		1		1		1	CUSTOMER
17	LOCK		2		2		2	NAT. GRID
16	NIPPLE 1 ¼". 1 ½" OR 2" X 3" LONG, GALV. SCH. 40		1		1		1	CUSTOMER
15	ELBOW 1-1/4" GALV. 90 DEGREE		3		3		3	CUSTOMER
14	RUBBER WASHER FOR METER SWIVEL	9342480	2	9342480	2	9342480	2	NAT. GRID
13	ITEM DELETED							
12	METER SWIVEL 1 ¼" X 45 LIGHT	9342425	2	9342425	2	9342425	2	NAT. GRID
11	METER NUT GALV. 45 LT	9340788	2	9340788	2	9340788	2	NAT. GRID
10	A. REGULATOR 2" SCR'D FISHER CS-8061R OR S302/ITRON B34SR (5"-9" OUTLET SPRING RANGE) B. REGULATOR 1 ½" SCR'D FISHER S302/ITRON B34SR (5"-9" OUTLET SPRING RANGE) SEE NOTE "K" C. REGULATOR 1 ¼" SCR'D AMER 1813B2 OR EQ. FOR 99 AND 124 PSIG SERVICES ONLY D. REGULATOR 1 ¼" SCR'D ITRON B31R OR AMER 1813 B2 WITH 3/16" ORIFICE FOR 60 PSIG MAX	SEE TABLE ON PG 1	1	SEE TABLE ON PG 1	1	SEE TABLE ON PG 1	1	NAT. GRID
9	METER CLASS 800		1		1		1	NAT. GRID
8	UNION – INSULTAING GALV. 1 ½" , 1 ¼" OR 2"	9341685	1	9341686	1	9341687	1	NAT. GRID
7	NIPPLE – LENGTH AS REQUIRED X REGULATOR SIZE OR RISER SIZE FOR LOW PRESSURE SERVICES		1		1		1	NAT. GRID
6	ELBOW – 1 – ½" X 1-1/4" GALV. 90 DEGREE, THREADED FOR 1 – ½" REGULATORS ELBOW – 2" X 1-1/4" GALV. 90 DEGREE, THREADED – FOR 2" REGULATORS ELBOW – 1 – ¼" GALV. 90 DEGREE, THREADED FOR 1 ¼" REGULATORS		- - 1		1 - -		- 1 -	CUSTOMER
5	PLUG VALVE – SERVICE SIZE 1 – ¼", 1 ½" OR 2" THREADED ENDS. ALTERNATE: 2" FLANGED PLUG VALVE (ITEM 382214 – SEE NOTE R)	9339609	1	9341952	1	9341953 OR 9341980	1 1	NAT. GRID NAT. GRID
4	ITEM DELETED		0		0		0	CUSTOMER
3	SERVICE LOCATION TAG – LONG ISLAND INSTALLATIONS ONLY	9340255	1	9340255	1	9340255	1	NAT. GRID
2	NIPPLE – SERVICE SIZE X LENGTH AS REQUIRED, GALV. SCH. 40		1		1		1	NAT. GRID
1	RISER	1 ¼"	1	1 ½"	1	2"	1	NAT. GRID
<b>No.</b>	<b>ITEM</b>	<b>NAT. GRID CODE No.</b>						

**BILL OF MATERIAL FOR CLASS 800 METER FIGURE 2 (WITHOUT BYPASS)**

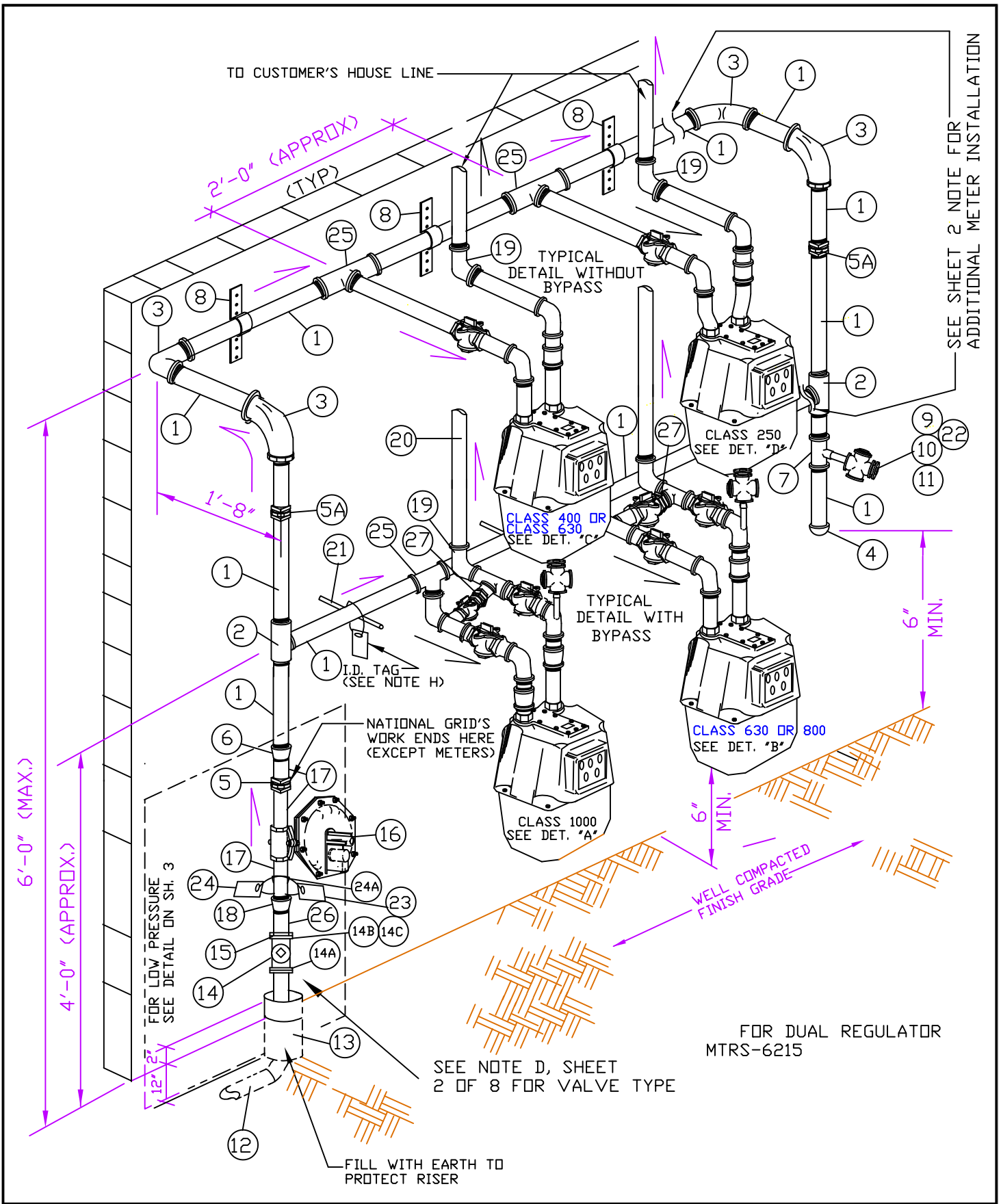
NO.	ITEM	1 ¼" SERVICE	QTY	1 ½" SERVICE	QTY	2" SERVICE	QTY	SUPPLIED BY
26	NIPPLE 2" X 2 ½" LONG LENGTH, GALV, SCH 40		2		2		2	CUSTOMER
25	NIPPLE 2" X 4" LONG LENGTH, GALV, SCH 40		2		2		2	CUSTOMER
24	REDUCER 1 ¼" X 2" GALVANIZED		2		2		2	CUSTOMER
23	REDUCER 1 ¼" X 2" GALV. (FOR 1 ¼" SERVICES THAT USE 2" REGULATOR)	9342614	1		0		0	NAT. GRID
22	NIPPLE – 2" X AS REQUIRED LENGTH, GALV, SCH 40		3		3		3	CUSTOMER
21	TEE – 2" X ¾" X 2" – HEEL – M.I. GALV., THREADED		1		1		1	CUSTOMER
20	VALVE LOCKWING, MUELLER TAMPER-PROOF H-11118 – LOCK CLOSED ¾"		1		1		1	CUSTOMER
19	NIPPLE ¾" X 4" GALV. SCH. 40		1		1		1	CUSTOMER
18	PLUG – ¾" GALV.		1		1		1	CUSTOMER
17	LOCK		2		2		2	NAT. GRID
16	NIPPLE 1 ¼". 1 ½" OR 2" X 3" LONG, GALV. SCH. 40		1		1		1	CUSTOMER
15	ELBOW 2" GALV. 90 DEGREE		3		3		3	CUSTOMER
14	RUBBER WASHER FOR METER SWIVEL	9342480	2	9342480	2	9342480	2	NAT. GRID
13	ITEM DELETED							
12	METER SWIVEL 1 ¼" X 45 LIGHT	9342425	2	9342425	2	9342425	2	NAT. GRID
11	METER NUT GALV. 45 LT	9340788	2	9340788	2	9340788	2	NAT. GRID
10	A. REGULATOR 2" SCR'D FISHER CS-806IR OR S302/ITRON B34SR (5"-9" OUTLET SPRING RANGE) B. REGULATOR 1 ½" SCR'D FISHER S302/ITRON B34SR (5"-9" OUTLET SPRING RANGE) SEE NOTE "K" C. REGULATOR 1 ¼" SCR'D FISHER AMER. 1813B2 OR EQ. FOR 99 AND 124 PSIG SERVICES ONLY D. REGULATOR 1 ¼" SCR'D ITRON B31R WITH 3/16" ORIFICE FOR 60 PSIG MAX	SEE TABLE ON PG 1	1	SEE TABLE ON PG 1	1	SEE TABLE ON PG 1	1	NAT. GRID
9	METER CLASS 1000		1		1		1	NAT. GRID
8	UNION – INSULTAING GALV. 1 ½" , 1 ¼" OR 2"	9341685	1	9341686	1	9341687	1	NAT. GRID
7	NIPPLE – LENGTH AS REQUIRED X REGULATOR SIZE OR RISER SIZE FOR LOW PRESSURE SERVICES		1		1		1	NAT. GRID
6	ELBOW – 1 – ½" X 2" GALV. 90 DEGREE, THREADED FOR 1 – ½" AND 1 – ¼" HP SERVICES ELBOW – 2" GALV. 90 DEGREE, THREADED – FOR 2" SERVICES ELBOW – 1 – ¼" X 2" GALV. 90 DEGREE, THREADED FOR 1 ¼" REGULATORS		- - 1		1 - -		- 1 -	CUSTOMER
5	PLUG VALVE – SERVICE SIZE 1 – ¼", 1 ½" OR 2" THREADED ENDS. ALTERNATE: 2" FLANGED PLUG VALVE (ITEM 382214 – SEE NOTE R)	9339609	1	9341952	1	9341953 OR 9341980	1 1	NAT. GRID NAT. GRID
4	TEE 2" X 2" GALV. SCREWED ENDS		0		0		0	CUSTOMER
3	SERVICE LOCATION TAG – LONG ISLAND INSTALLATIONS ONLY	9340255	1	9340255	1	9340255	1	NAT. GRID
2	NIPPLE – SERVICE SIZE X LENGTH AS REQUIRED, GALV. SCH. 40		1		1		1	NAT. GRID
1	RISER	1 ¼"	1	1 ½"	1	2"	1	NAT. GRID
<b>No.</b>	<b>ITEM</b>	<b>NAT. GRID CODE No.</b>						

**BILL OF MATERIAL FOR CLASS 1000 METER FIGURE 2 (WITHOUT BYPASS)**

**NOTES:**

- A. KEY REQUIREMENTS FOR THE CONSTRUCTION OF METER HEADERS AND METER INSTALLATION ARE CONTAINED IN NATIONAL GRID SPECIFICATIONS CUST-5235 AND THE NATIONAL GRID BLUE BOOK.
- B. WHERE VEHICULAR TRAFFIC IS A CONCERN, INSTALL PROTECTION POSTS. SEE APPROVED NATIONAL GRID SPECIFICATION FOR PROTECTION POST INSTALLATION REQUIREMENTS AND SPECIFICATIONS.
- C. METERS AND SAFETY DEVICES MUST BE PROTECTED FROM DAMAGE DURING PRESSURE TEST.
- D. ADDITIONAL FITTINGS MAY BE REQUIRED TO MAKE THE METER INSTALLATION.
- E. NATIONAL GRID ENERGY SHALL NOT BE RESPONSIBLE FOR FITTING DIMENSIONS OR FOR SCALED DIMENSIONS.
- F. IF BRANCH LOAD IS REQUIRED, SEE APPROPRIATE NATIONAL GRID DRAWINGS FOR METER SIZING, PIPE DESIGN AND VALVE REQUIREMENTS. BRANCH PIPING IS TO BE ELECTRICALLY INSULATED FROM DISTRIBUTION PIPING AT VALVE.
- G. COAT ALL NON-GALVANIZED PIPE AND FITTINGS WITH RUSTOLEUM #7715 OR EQUAL. TWO COATS REQUIRED, BRUSH APPLIED.
- H. FOR UNDERGROUND PIPING AFTER METER, CONTACT CORROSION CONTROL SECTION FOR NATIONAL GRID ENERGY'S REQUIREMENTS.
- I. ALL MAXIMUM CFH'S ARE MEASURED AT 1.0" WATER COLUMN DROP ACROSS THE METER.
- J. A FULLY ENCLOSED (INCLUDING TOP) CHAIN LINK FENCE (CYCLONE) MINIMUM 8FT. HIGH WITH GATE AND LOCK MAY BE REQUIRED ON OUTSIDE SETS DEPENDING ON LOCATION. TO BE SUPPLIED BY CUSTOMER.
- K. THE 2" S-302 OR ITRON/ITRON B34 SR REGULATOR COMES STANDARD WITH A 7/32" X 1/4" ORIFICE (60# MAX.). THE 1-1/2" S-302 OF ITRON B34SR REGULATOR COMES STANDARD WITH A 3/8" ORIFICE (15# MAX.).  
**FOR 99 AND 124 PSIG INLET PRESSURES** INSTALL AN 1-1/2" OR A 2" S-302 OR B34SR REGULATOR AND CHANGE THE ORIFICE TO 5/32"X 3/16" ORIFICE (ITEM ID 9383243 FOR FISHER S302 OR ITEM ID 9324362 FOR ITRON B34SR). FAILURE TO CHANGE THE ORIFICE WILL CAUSE DAMAGE TO THE REGULATOR. AN ALTERNATE OPTION ON THE 99#/124# SYSTEM IS TO USE THE 1- 1/4" FISHER HSR OR ITRON B-42R, B31R OR AMERICAN 1813B2 OR SR-100 WITH 1/8" ORIFICE (ITEM ID 9383127).  
**FOR 60 PSIG SYSTEMS** INSTALL AN 1-1/4" ITRON B-31R REGULATOR (ITEM I D 9342206) OR INSTALL A 2" S-302 / B34SR WHICH HAS A 7/32" X 1/4" ORIFICE OR INSTALL A 1-1/2" S-302/ITRON B34SR AND CHANGE THE ORIFICE TO 7/32" X 1/4" (ITEM ID 9383242 FOR FISHER AND ITEM ID 9324363 FOR ITRON). A 2" B34IMRV (ITEM ID 9342684) IS ALSO ACCEPTABLE FOR 60 PSIG INLETS.  
**FOR 15 PSIG SERVICE**, INSTALL AN 1 1/2" S-302 OR ITRON B34SR WHICH HAS A 3/8" DIAM. ORIFICE. OR USE A 2" S-302 OR ITRON B34SR AND CHANGE THE ORIFICE TO 3/8" (ITEM ID 9 FOR FISHER S302 OR ITEM ID 9324359 FOR ITRON B34SR). THIS REGULATOR HAS A MAX. INLET PRESSURE OF 15 PSIG.  
**THE REGULATOR VENT ASSEMBLY MUST BE FACE DOWN AND EQUIPPED WITH A RAIN AND INSECT RESISTANT SCREEN. FOR NEW CONSTRUCTION OR ALTERATIONS SEE 020013-CS FOR VENT PIPING LOCATION. IT IS PREFERRED THAT REGULATOR VENTS BE INSTALLED AT A HEIGHT 18 INCHES ABOVE GRADE, HOWEVER, THE MINIMUM ALLOWABLE VENT HEIGHT SHALL BE 12 INCHES ABOVE FINAL GRADE. IN CASES OF KNOWN FLOOD LOCATIONS, THE PREFERRED REGULATOR VENT HEIGHT ABOVE THE FLOOD HEIGHT IS 18" (12" MINIMUM). A MINIMUM OF 18 INCHES MUST BE MAINTAINED FROM ANY OPENING WHERE GAS MAY ENTER THE PREMISE.**
- L. ALL PIPING SHALL BE IN COMPLIANCE WITH NFPA 54.
- M. RISER SHALL BE A MINIMUM OF 12" FROM THE OUTSIDE BUILDING FOUNDATION WALL.
- N. THE METER AND ASSOCIATED PIPING SHALL BE PLUMB AND LEVEL FROM BOTH FRONT AND SIDE.
- O. ALL FITTINGS SHALL BE GALVANIZED OR BLACK PIPE PRIMED AND PAINTED.
- P. SERVICE LOCATION TAGS ARE REQUIRED ON LONG ISLAND INSTALLATIONS ONLY.
- Q. WHEN USING A 2" FLANGED VALVE, USE THE FOLLOWING:  
 2" INSULATING FLANGED KIT QTY 1 – ITEM ID 9340992  
 2" THREADED NIPPLE WITH FLANGE QTY 1 – ITEM ID 9383856  
 MACHINE BOLTS – 5/8" X 2 – 3/4" QTY – ITEM ID 9339766
- R. AT FLOW RATES OF 700 CFH AND 800 CFH, THE PRESSURE DROP OF THE 800 METER SET WITH THE BYPASS IS APPROXIMATELY 1.5" W.C. (INCLUDING THE METER). ON LOW PRESSURE SYSTEMS, WHERE TOTAL CONNECTED LOAD APPROACHES 800 CFH, IT IS RECOMMENDED TO USE 2" PIPING.
- S. FOR 14" W.C. (1/2 PSIG) METERING, CONTACT METER OPERATIONS FOR PROPER METER WITH INDEX.
- T. FOR 14" METERING, THE REGULATOR SPRING MUST BE CHANGED.

Vent Line Pipe Size	
Length	Pipe Size
0' – 50'	1 – 1/2"
50' – 100'	2"
>100'	Cont. Gas Eng.



**nationalgrid**

LONG ISLAND

**TYPICAL MULTIMETER CONFIGURATION FOR CLASS 250, 400, 630, 800 AND 1000 WITH SINGLE REGULATOR**

**REVISIONS:** REVISED PAGE 2 WITH NEW SAP ITEM ID'S

DATE: 07/10/2004

EFFECTIVE DATE: 09/15/2013

DESIGN: MLoP

STD. DWG.

DRAWN: PAUL GUGLIOTTA

NO. **MTRS-6215**



BILL OF MATERIAL		APPLICATION FOR FOUR (4) METER SETS	
ITEM NO.	DESCRIPTION	QUANTITY	ITEM ID
1	PIPE SIZE AND LENGTH AS REQ'D (SEE SHEET 3)	+	**
2	TEE (EQUAL TO SIZE OF HEADER)	2	**
3	ELBOW - 90°	4	**
4	CAP - SIZE AS REQUIRED	1	**
5	UNION - INSULATED (ONLY IF SCREWED VALVE IS USED)	1	**
5A	UNION (PLUMBER'S OPTION)	2	**
6	REDUCER (IF REQUIRED)	1	**
7	TEE - BULL, SIZE AS REQUIRED	1	**
8	1 5/8" UNISTRUT CHANNEL W/CLAMP	+	**
9	NIPPLE 3/4" X 3"	1	**
10	VALVE - LOCKWING 3/4"	1	**
11	PLUG SCREWED 3/4"	1	**
12	RISER - SERVICE (PRIMED & PAINTED) SIZE AS REQUIRED	1	NAT. GRID
13	SLEEVE - PIPE, PLASTIC OR EQUIVALENT	1	NAT. GRID
14	VALVE (SEE NOTE BELOW)	1	NAT. GRID
14A	GASKET - SET - INSULATED FLANGE KIT (FOR FLANGE VALVE)	1	NAT. GRID
14B	BOLTS MACHINE (5/8" X 2 3/4") A307	8	9339766
14C	FLANGE - WELD NECK (FOR FLANGED TYPE VALVE ONLY)	2	NAT. GRID
15	GASKET - RING FOR FLANGE VALVES	1	NAT. GRID
16	REGULATOR - 1 1/4" OR 2" RELIEF/MONITOR	1	*
17	NIPPLE	+	NAT. GRID
18	REDUCER (IF REQUIRED)	1	NAT. GRID
19	ELBOW - SIZE AND QUANTITY AS REQ'D	+	**
20	PIPE - HOUSE LINE SIZE AND QUANTITY AS REQ'D	+	**
21	SUPPORT - PIPE OR ROD 1"	+	**
22	GAS SNAP LOCK	1	9330915
23	SYSTEM PRESSURE TAG	1	9346233
24	TAG - GAS SERVICE LOCATION (CPR TAG)	1	9340255
24A	SELF LOCKING NYLON STRIP 14"	1	NON STOCK
25	TEE - 1 PER METER, SIZE AS REQUIRED (SEE DET. A,B,C,D,E)	+	**
26	NIPPLE - AS REQUIRED	+	**
27	UNION - 2" FOR 1000 METER/ 1-1/4" FOR 630/750/800 METER - GALV.	1	**
44	REDUCER - 2" X 1-1/4"	2	**

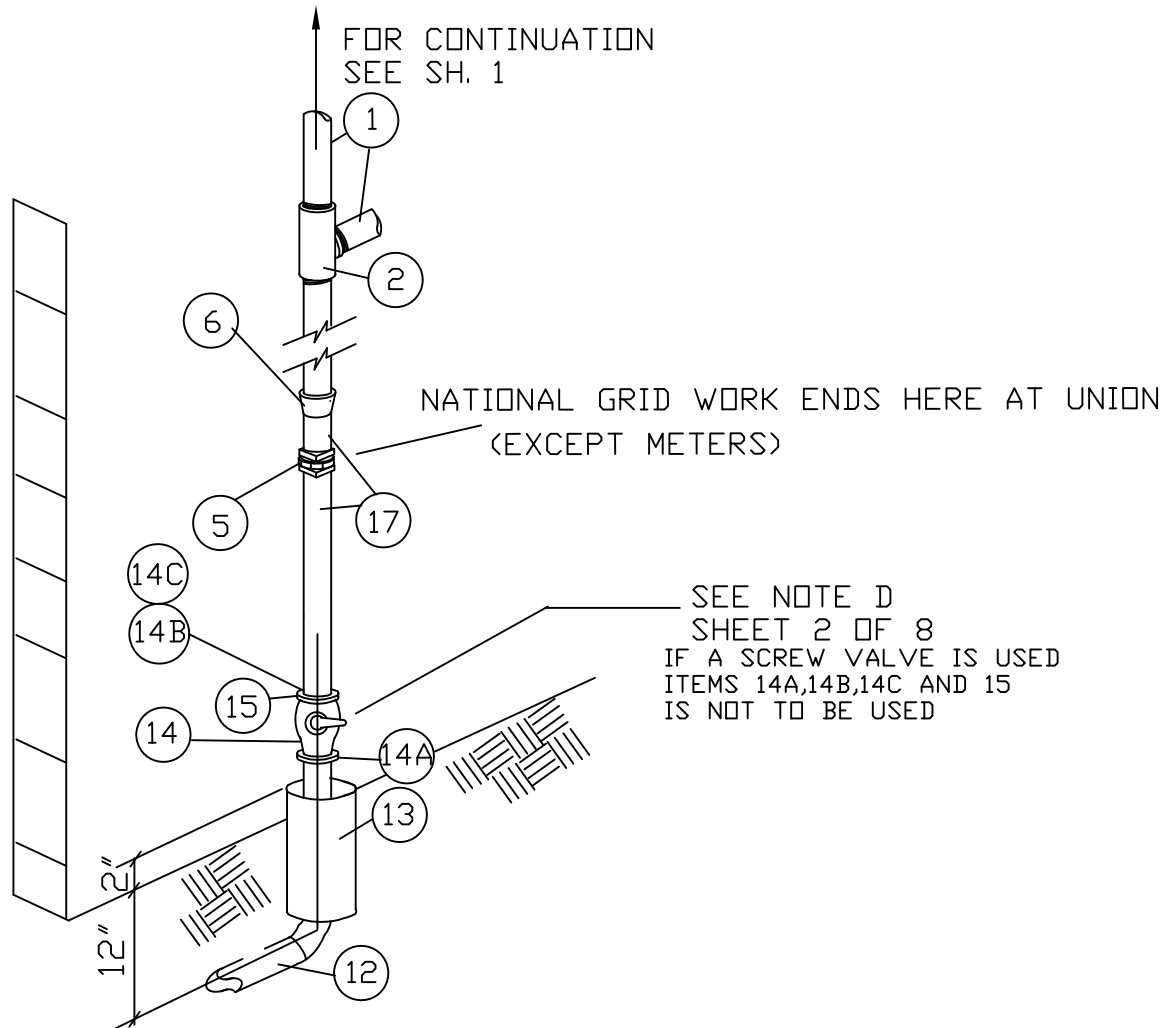
**LEGEND:**

- + - AS REQUIRED
- ++ - TO BE SUPPLIED BY NATIONAL GRID.
- \*\* - SUPPLIED BY CUSTOMER
- \* - SEE cms-03002 FOR PROPER REGULATOR AND SELECTION & SIZING.

**NOTES (FOR SHEET 1)**

- A - FOR ITEM ID'S ON ITEMS 28 THRU 43 SEE SHEETS 4 THRU 7 WHICHEVER APPROPRIATE CLASS OF METER APPLIES
- B - NATIONAL GRID WILL SUPPLY AND INSTALL ITEMS 12 THRU 18 AND ITEMS 22 THRU 24A.
- C - SEE SHEET 3 FOR DIFFERENT METER HEADER PIPE SIZES.
- D - USE SCREW TYPE VALVE FOR 1-1/4" RISER, FOR 2" RISER USE FLANGE TYPE VALVE. IF A SCREW VALVE IS USED, ITEMS 14A, 14B, 14C AND 15 IS NOT REQUIRED.
- E - IF ADDITIONAL METER SETS ARE REQUIRED THEN ADD A FULL TEE (ITEM 25) TO TOP OR LOWER MANIFOLD LEVELS SEE SH. 1.
- F - 1000 CLASS METERS MUST USE 2" PIPING AND REDUCE DOWN TO 1-1/4" FOR METER CONNECTIONS.
- G - ON THE 99 AND 124 PSIG SYSTEMS, THE 2" REGULATOR MUST HAVE THE DRIFICE CHANGED TO 3/8". ON THE 99 AND 124 PSIG SYSTEM, THE 1-1/4" REGULATOR ITEM ID IS 357046.
- H - CUSTOMER TO INSTALL PERMANENT BRASS OR ALUMINUM TAG ON EACH METER INDICATING CUSTOMER'S ADDRESS/ STORE #/ APARTMENT #/ OR UNIT. THIS INFORMATION SHALL BE ENGRAVED OR STAMPED ON THE TAG.

FOR LOW PRESSURE SERVICE  
(SEE SH.1, FOR INFORMATION NOT SHOWN)



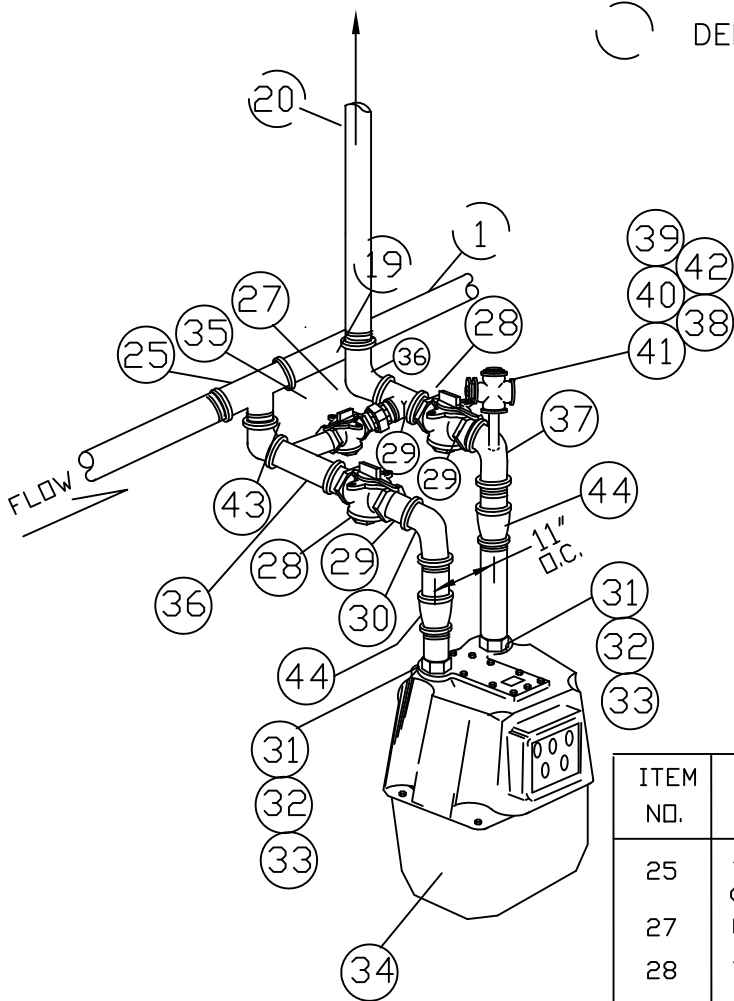
ALLOWABLE LOADS FOR DIFFERENT METER HEADER PIPE SIZES.

PIPE SIZE	1-1/4"	1-1/2"	2"	2-1/2"	3"	4"
MAX. ALLOWABLE LOAD	750 CFH	1350 CFH	2250 CFH	2750 CFH	3700 CFH	4550 CFH

- 1 -MAXIMUM CAPACITY BASED ON PREFERABLY TWO ROWS. LAYOUT AS SHOWN ON MTRS-6215 AND MTRS-6225 ONLY.
- 2 -FOR A SINGLE TIER LAYOUT, SEE MTRS-6075
- 3 -THE METER CLASS SHALL BE USED AS INDICATED IN MTRS-6075, SHEET 1 OF 2. SPECIAL ATTENTION IS REQUIRED ON NOTE A, SHEET 8 OF 8.
- 4 -THIS LOADING IS THE MAXIMUM THAT SHOULD BE PLACED ON THE SPECIFIED SIZE CUSTOMER INSTALLED PIPING. THE CUSTOMER SHOULD BE ADVISED THAT AN INCREASED SIZE COULD PROVIDE FOR UNKNOWN OR POSSIBLE INCREASED LOAD.

TO CUSTOMER'S  
HOUSE LINE

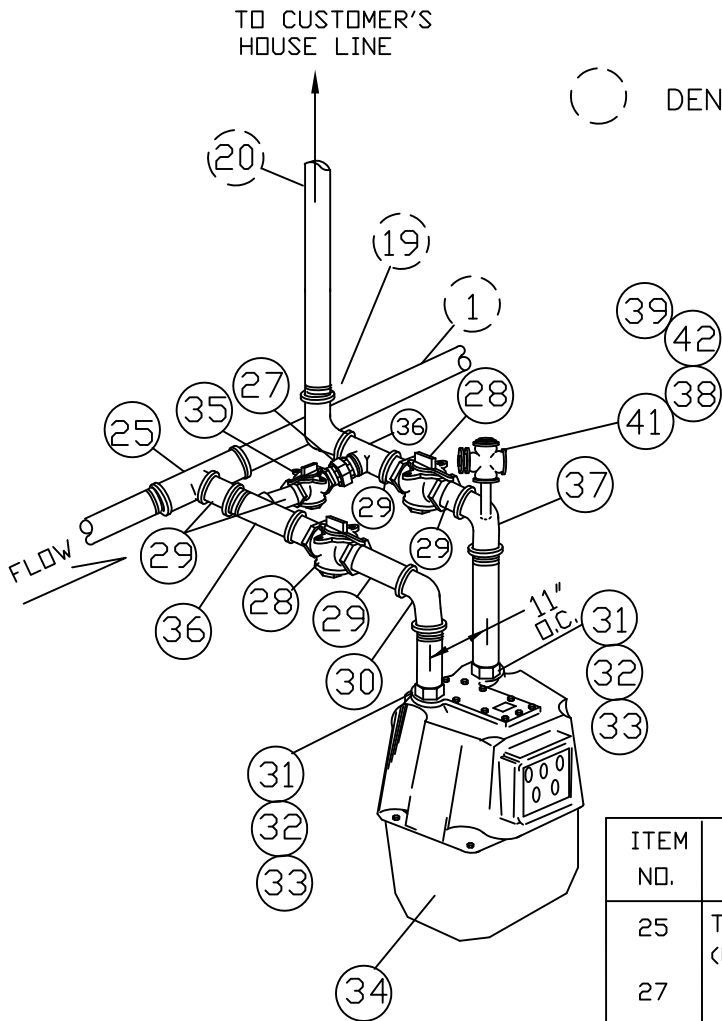
○ DENOTE EXISTING (SEE SH.1)



DETAIL "A"  
CLASS 1000 METER  
AND CLASS 800  
METER ON LOW  
PRESSURE SERVICES

ITEM NO.	DESCRIPTION	QUAN TITY	ITEM ID
25	TEE : SIZE AS REQUIRED (USE BULL TEE IF NECESSARY)	1	**
27	UNION - 2"	1	**
28	VALVE - LOCKWING - 2"	2	**
29	NIPPLE 2"	+	**
30	ELBDW 90° - 2"	2	**
31	SWIVEL - 1-1/4" 45 LT	2	9342425
32	NUT - METER - 1000 45 LT	2	9340788
33	METER NUT GASKET - 1000	2	9342480
34	GAS METER - 1000 CFH	1	++
35	VALVE - LOCKWING 2" BY PASS	1	9339610
36	TEE - 3WAY 2"x 2"x 2"	2	**
37	TEE - HEEL 2"x 2"x 3/4"	1	**
38	PLUG SCREW 3/4"	1	**
39	GAS SNAP LOCK	1	9386820
40	NOT TO BE USED	-	-
41	NIPPLE 3/4"x 3"	1	**
42	VALVE - LOCKWING 3/4"	1	**
43	NIPPLE 2"	+	**
44	REDUCER 2" X 1-1/4"	2	**

NOTE: NAIONAL GRID WILL SUPPLY AND INSTALL ITEMS 31 THRU 35, 39 AND 40



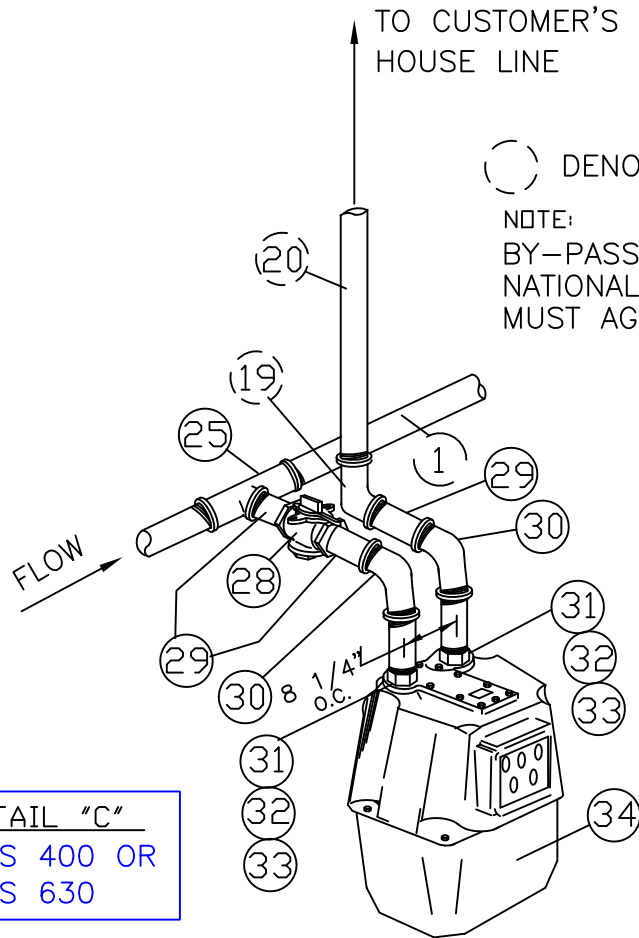
( ) DENOTE EXISTING (SEE SH.1)

**DETAIL "B"**  
 CLASS 630  
 CLASS 800

ITEM NO.	DESCRIPTION	QUANTITY	ITEM ID
25	TEE : REDUCER, SIZE AS REQUIRED (USE BULL TEE IF NECESSARY)	1	**
27	UNION - 1 1/4"	1	**
28	VALVE - LOCKWING - 1-1/4"	2	**
29	NIPPLE 1-1/4"	+	**
30	ELBOW 90° - 1-1/4"	1	**
31	SWIVEL-METER-1 1/4"x45 LIGHT	2	9342425
32	NUT - METER - 45 LIGHT	2	9340788
33	GASKET - METER NUT	2	9342480
34	GAS METER CLASS - 630 CFH OR GAS METER CLASS - 800 CFH	1	++
35	VALVE- LOCKWING - 1 1/4"	1	9339609
36	TEE 1-1/4"	2	**
37	TEE - HEEL 1-1/4"x 3/4"x 1-1/4"	1	**
38	PLUG SCREW 3/4"	1	**
39	GAS SNAP LOCK	1	9330915
40	NOT TO BE USED	-	-
41	NIPPLE 3/4"x 3"	1	**
42	VALVE - LOCKWING 3/4"	1	**

**NOTE:**  
 FOR LOW PRESSURE SERVICES,  
 2" PIPING IS RECOMMENDED TO 800  
 CLASS METER. USE DESIGN FOR  
 1000 METER ON PAGE 4.

NOTE: NATIONAL GRID WILL SUPPLY AND INSTALL ITEMS 31 THRU 35, 39 AND 40



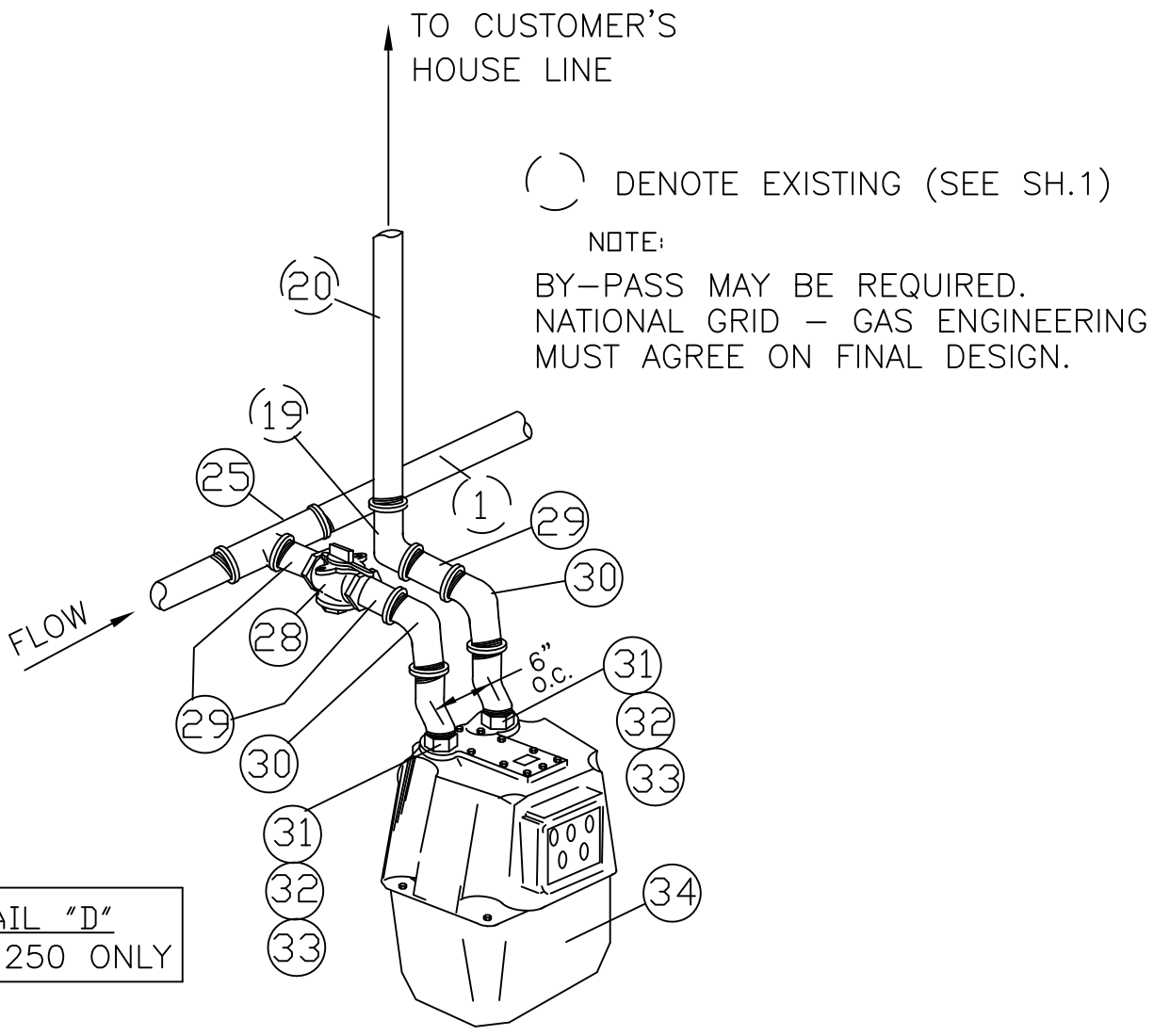
( ) DENOTE EXISTING (SEE SH.1)

NOTE:  
BY-PASS MAY BE REQUIRED.  
NATIONAL GRID - GAS ENGINEERING  
MUST AGREE ON FINAL DESIGN.

DETAIL "C"  
CLASS 400 OR  
CLASS 630

ITEM NO.	DESCRIPTION	QUAN TITY	M & S CODE
25	TEE : REDUCER, SIZE AS REQUIRED (USE BULL TEE IF NECESSARY)	1	**
28	VALVE - LOCKWING - 1-1/4"	1	**
29	NIPPLE 1-1/4"	+	**
30	ELBOW 90°- 1-1/4"	2	**
31	SWIVEL METER - 1-1/4"X 45 LIGHT	2	9342425
32	METER NUT - 45 LIGHT	2	9340788
33	NUT - METER WASHER - 45 LIGHT	2	9342480
34	METER - GAS - CLASS - 400 CFH OR METER - GAS - CLASS - 630 CFH	1	++

NOTE: NATIONAL GRID WILL INSTALL AND SUPPLY ITEMS 31 THRU 34



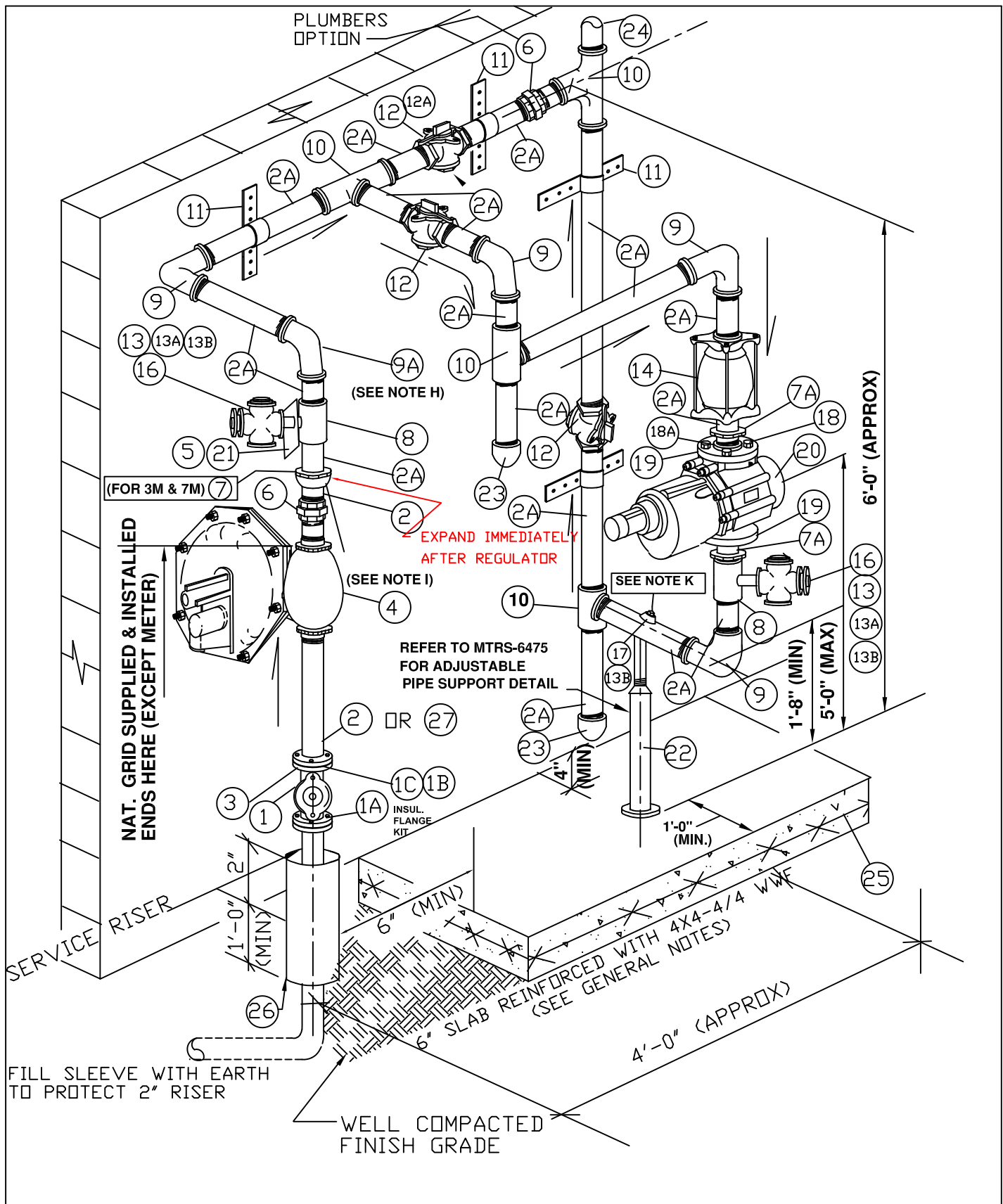
ITEM NO.	DESCRIPTION	QUANTITY	ITEM ID
25	TEE : REDUCER, SIZE AS REQUIRED (USE BULL TEE IF NECESSARY)	1	**
28	VALVE - LOCKWING - 1"	1	**
29	NIPPLE 1"	+	**
30	ELBOW 90° DEGREES- 1"	2	**
31	SWIVEL - METER - 1"X 20 LIGHT	2	9383109
32	NUT - METER - 20 LIGHT	2	9340787
33	WASHER - METER NUT - 20 LIGHT	2	9342478
34	METER - CLASS - 250 CFH	1	++

NOTE: NATIONAL GRID WILL INSTALL AND SUPPLY ITEMS 31 THRU 34

**NOTES**

- A. IT IS PREFERRED TO HAVE THE LARGEST METER PLACED CLOSEST TO THE REGULATOR OUTLET AS SHOWN ON SHEET 1. HOWEVER, THE DETAILS OF EACH METER CAN BE REARRANGED IF THE FIELD CONDITIONS WARRANT IT.
- B. FOR ADDITIONAL METER SET LAYOUTS, SEE DETAIL "A", "B", "C" AND "D".
- C. FOR ANY MANIFOLD PIPE SIZE, THE ALLOWABLE MAXIMUM LOAD IS SHOWN ON SHEET 3.
- D. THIS CONSTRUCTION STANDARD SHALL ONLY BE USED FOR OUTSIDE METER SETS.
- E. METERS CAN BE INSTALLED EITHER TO THE RIGHT OR THE LEFT OF THE SERVICE RISER.
- F. THE METER PIPING SHALL BE INSTALLED SO THAT THE TOP OF THE METERS IS NO HIGHER THAN 6 FEET ABOVE FINISH GRADE. THE PURGE SHALL ALSO BE NO LOWER THAN 6 INCHES FROM FINISH GRADE.
- G. CONTRACTORS TO COMPLY WITH ADDITIONAL HEADER DIMENSIONS.
- H. APPROPRIATE APARTMENT NUMBERS, STORE NUMBERS, ADDRESS OR NAME SHALL ENGRAVED OR STAMPED ON A PERMANENT BRASS OR ALUMINUM TAG AND ATTACHED TO THE METER OUTLET PIPING.
- I. USE GALVANIZED PIPING FOR OUTSIDE METER SETS.
- J. CUSTOMER PIPING WHICH IS NOT READY FOR SERVICE WHEN HEADER IS FABRICATED SHALL BE FITTED AT THE RISER WITH A LOCKWING VALVE, AND THE LINE PLUGGED.
- K. REFER TO THE SERVICES SECTION FOR SERVICE INSTALLATION. REGULATORS SHALL BE SIZED PROPERLY.
- L. SERVICE RISER, METER HEADER AND METER SHALL BE LOCATED TO PREVENT DAMAGE CAUSED BY VEHICLES OR MECHANICAL EQUIPMENT.
- M. THE CONTRACTOR SHALL BE RESPONSIBLE FOR INSTALLATION OF ANY REQUIRED VENT PIPING. PIPE SIZE AND VENT TERMINATION LOCATION SHALL BE AGREED TO BY BEFORE STARTING WORK.
- N. ALL BY-PASS VALVES SHALL BE LOCATIONAL GRID CLOSED BY NATIONAL GRID.
- O. SERVICE RISER SHALL NOT BE ENCASED IN CONCRETE, BLACKTOP OR ANY PAVEMENT MATERIALS.
- P. UNLESS OTHERWISE SPECIFIED, ALL CUSTOMER OWNED PIPING MUST BE IN COMPLIANCE WITH NFPA-54 AND SPECIFICATIONS AND REQUIREMENTS FOR GAS INSTALLATIONS.
- Q. THE GAS SERVICE LOCATION TAG SHALL BE INSTALLED BY NATIONAL GRID PER CUST- 5230.
- R. ALL PIPING, FITTINGS, ETC. SHALL BE INSPECTED FOR DEFECTED AND THOROUGHLY CLEANED OF ALL FOREIGN MATTER BEFORE BEING INSTALLED.
- S. PIPE STRAPS OR HANGERS SHALL BE USED FOR SUPPORT. THE PLACEMENT OF THE SUPPORTS DEPENDS ON THE CONFIGURATION OF THE METER SET AND CUSTOMER'S HOUSE LINE.
- T. THE METER VALVE SHALL FACE FORWARD FROM THE WALL FOR EASY ACCESSIBILITY, WHENEVER POSSIBLE.
- U. THE INSULATED FLANGE KIT, WHEN USED, SHALL BE INSTALLED ON THE SERVICE LINE VALVE BY NATIONAL GRID.
- V. AT TIMES OF INSTALLATION ALL SERVICE LINES SHALL BE PLUMB AND LEVEL.

<b>No.</b>	<b>ITEM</b>	<b>NATIONAL GRID CODE No.</b>
<b>BILL OF MATERIAL</b>		



**nationalgrid**

LONG ISLAND

**HP MAIN / LP, 1/2 PSIG & 1 PSIG METERING  
FOR 8C, 1.5M, 3M OR 7M  
VERTICAL-ROTARY GAS METER**

**REVISIONS:** REVISED USING SAP ITEM ID #'S

DATE: 07/01/2003

EFFECTIVE DATE: 09/15/2013

DESIGN: JAL

STD. DWG.

DRAWN: HF

NO. **MTRS-6255**



**NOTES**

- A. SEE GENERAL NOTES MTRS – 6545  
 B. ALL THREADED TYPE PIPE AND FITTINGS TO BE HOT DIPPED GALVANIZED  
 C. ALL FITTING SHALL BE MALLEABLE IRON CLASS 150, ANSI B 16.3  
 D. CINCH ANCHORS OR EQUIVALENT TO BE INSTALLED IN FLOOR FLANGES (ITEM 21) BY CUSTOMER.  
 E. FOR UNDERGROUND CUSTOMER'S HOUSE PIPING REFER TO DESIGN SECTION  
 F. NAT. GRID WILL SUPPLY AND INSTALL ITEMS 1 THRU 5 (EXCEPT 2A), 112A, 16,18A THRU 20 AND 26.  
 G. ITEM 4 AND 20 CAN BE ROTATED TO FIT FIELD CONDITIONS  
 H. THE CUSTOMER MAY AT HIS OPTION INSTALL A VERTICAL PRESSURE TAP AT ITEM 9A IF A HEEL TEE IS USED.  
 I. FOR LOADS UPTO 1500 CFH 2" PIPING CAN BE USED AFTER THE REGULATOR.  
 J. **FOR 99 PSIG AND 124 PSIG INLETS, THE ITRON B34IMRV MUST HAVE THE ORIFICE CHANGED TO 3/8". FOR 124, FISHER S-302 AND FISHER S-203 REGULATOR MUST HAVE THEIR ORIFICES CHANGED TO 1/4". ITRON B34SR REQUIRES 5/32"X3/16" ORIFICE.**  
 K. FOR T.C. RATE INSTALLATIONS AND FOR METERING > 1 PSIG, A 3/4" THREADOLET IS NEEDED FOR A THERMOWELL. THIS MUST BE DRILLED OUT TO 7/8" DIAMETER. IF WELDING IS NOT FEASIBLE, USE A 2" X 2" THREADED TEE AND INSTALL A 2" X 3/4" BUSHING FOR THE THERMOWELL.  
 L. FOR 14" W.C. AND 1 PSIG METERING, CONTACT METER OPERATIONS FOR PROPER METER WITH INDEX.  
 M. SEE NATIONAL GRID DRAWING 020013-CS FOR REGULATOR VENT GUIDELINES.  
**LEGEND: X X SUPPLIED BY CUSTOMER \* SEE FOR PROPER DESIGN SECTION REGULATOR SELECTING AND SIZING**  
 + AS REQUIRED \*\* TO BE SUPPLIED BY NATIONAL GRID

27	2" THREADED NIPPLE X 2" 150# FALT FACE FLANGE	1	9383856
26	SLEEVE – 4" PIPE – PLASTIC OR EQUIVALENT	1	NAT. GRID
25	SLAB REINF – 4X4 – 4/4 WIRE WELDED FABRIC	1	X X
24	PIPE – HOUSE LINE	+	X X
23	CAP – 2" - THREADED	2	X X
22	PIPE SUPPORT – 2 1/2" – ADJUSTABLE SEE MTRS-6475	1	NAT. GRID
21	SYSTEM PRESSURE TAG	1	9346233
20	METER – LINE MOUNTED ROTARY – 8C OR 1.5M 125 – 2" INLET / OUTLET	1	**
19	GASKET RING - METER	2	9341161
18A	BOLT – 5 /8" X 2 ASTM A 307 GR B	8	9342411
18	FLANGE – 2" FF – COMPANION – ANSI CLASS 125 – THREADED OUTLET	2	X X
17	THREADOLET 2" X 3/4" SEE NOTE K	1	X X
16	GAS SNAPLOCK	2	9330915
14	COUPLING – 2" – COMPRESSION – DRESSER STYLE 38	1	X X
13B	PLUG – 3 /4" - THREADED	3	X X
13A	NIPPLE – 3 /4" X 3" - THREADED	2	X X
13	COCK – 3/4" - LOCKWING	2	X X
12A	LOCKING DEVICE	1	9330859
12	VALVE – 2" - THREADED	3	X X
11	CHANNEL – 1 5/8" - UNISTRUT W / CLAMP	+	X X
10	TEE – 2" - THREADED	4	X X
9,9A	ELBOW – 2" – 90 DEGREE - THREADED	5	X X
8	TEE – 2" X 3 /4" X 2" - THREADED	2	X X
7,7A	ITEM DELETED		
6	UNION – 2"	2	X X
5	TAG – GAS SERVICE LOCATION	1	9340255
4	REGULATOR – 2" TRON B34SR (1,100 CFH MAX) 60 PSIG MAX (5/32"X3/16" ON 99/124 PSIG SYSTEM) REGULATOR - 2" FISHER S-203 THREADED (NOTE THIS REGLULATOR WAS DISCONTINUED 7/30/2012) REGULATOR - 2" ITRON B34IMRV - THREADED - 1/2" ORIFICE – 60 PSIG MAX (3/8" REQ'D ON 99/124 SYS.) REGULATOR - 2" FISHER S-208 THREADED 1/2" ORIFICE – 100 PSIG MAX. (1/4" REQ'D ON 124 PSIG SYS) REGULATOR - 2" FISHER CS-806 IR THREADED 1/2" ORIFICE – 100 PSIG MAX. (3/8" REQ'D ON 99/124 SYS.) REGULATOR - 2" FISHER CS-803 IT THREADED 5/8" ORIFICE – 60 PSIG MAX. (1/4" REQ'D ON 99/124 SYS.)	1	9342660 9383314 9342684 9342184 9386776 9386778
3	GASKET RING – 2"	1	9341161
2A	PIPE – 2"	+	X X
2	PIPE- 2"	+	9340729
1C	FLANGE – 2" – WELDED NECK	2	9341058
1B	BOLTS – 5 /8" X 2 3 /4" A 307 - MACHINE	8	9339766
1A	GASKET SET – 2" - INSTALLED	1	9340992
1	VALVE – 2" FLANGED	1	9341980

No.	ITEM	ITEM ID
<b>BILL OF MATERIAL – 8C &amp; 1.5M METERS</b>		

**NOTES**

- A. SEE GENERAL NOTES MTRS – 6545
- B. ALL THREADED TYPE PIPE AND FITTINGS TO BE HOT DIPPED GALVANIZED
- C. ALL FITTING SHALL BE MALLEABLE IRON CLASS 150, ANSI B 16.3
- D. CINCH ANCHORS OR EQUIVALENT TO BE INSTALLED IN FLOOR FLANGES (ITEM 21) BY CUSTOMER.
- E. FOR UNDERGROUND CUSTOMER'S HOUSE PIPING REFER TO DESIGN SECTION
- F. NAT. GRID WILL SUPPLY AND INSTALL ITEMS 1 THRU 5 (EXCEPT 2A), 112A, 16,18A THRU 20 AND 26.
- G. ITEM 4 AND 20 CAN BE ROTATED TO FIT FIELD CONDITIONS
- H. THE CUSTOMER MAY AT HIS OPTION INSTALL A VERTICAL PRESSURE TAP AT ITEM 9A IF A HEEL TEE IS USED.
- I. INCREASE PIPE SIZE TO 3" WITHIN 12" AFTER THE REGULATOR.
- J. FOR 99 PSIG AND 124 PSIG INLETS, THE ITRON B34IMRV MUST HAVE THE ORIFICE CHANGED TO 3/8". FOR 124, FISHER S-302 AND FISHER S-203 REGULATOR MUST HAVE THEIR ORIFICES CHANGED TO 1/4".
- K. FOR T.C. RATE INSTALLATIONS AND FOR METERING > 1 PSIG, A 3/4" THREADOLET IS NEEDED FOR A THERMOWELL. THIS MUST BE DRILLED OUT TO 7/8" DIAMETER. IF WELDING IS NOT FEASIBLE, USE A 3" X 2" THREADED TEE AND INSTALL A 2" X 3/4" BUSHING FOR THE THERMOWELL.
- L. FOR 14" W.C. AND 1 PSIG METERING, CONTACT METER OPERATIONS FOR PROPER METER WITH INDEX.
- M. SEE NATIONAL GRID DRAWING 020013-CS FOR REGULATOR VENT GUIDELINES.

**LEGEND:**

- X X SUPPLIED BY CUSTOMER \* SEE FOR PROPER DESIGN SECTION REGULATOR SELECTING AND SIZING
- + AS REQUIRED \*\* TO BE SUPPLIED BY NATIONAL GRID

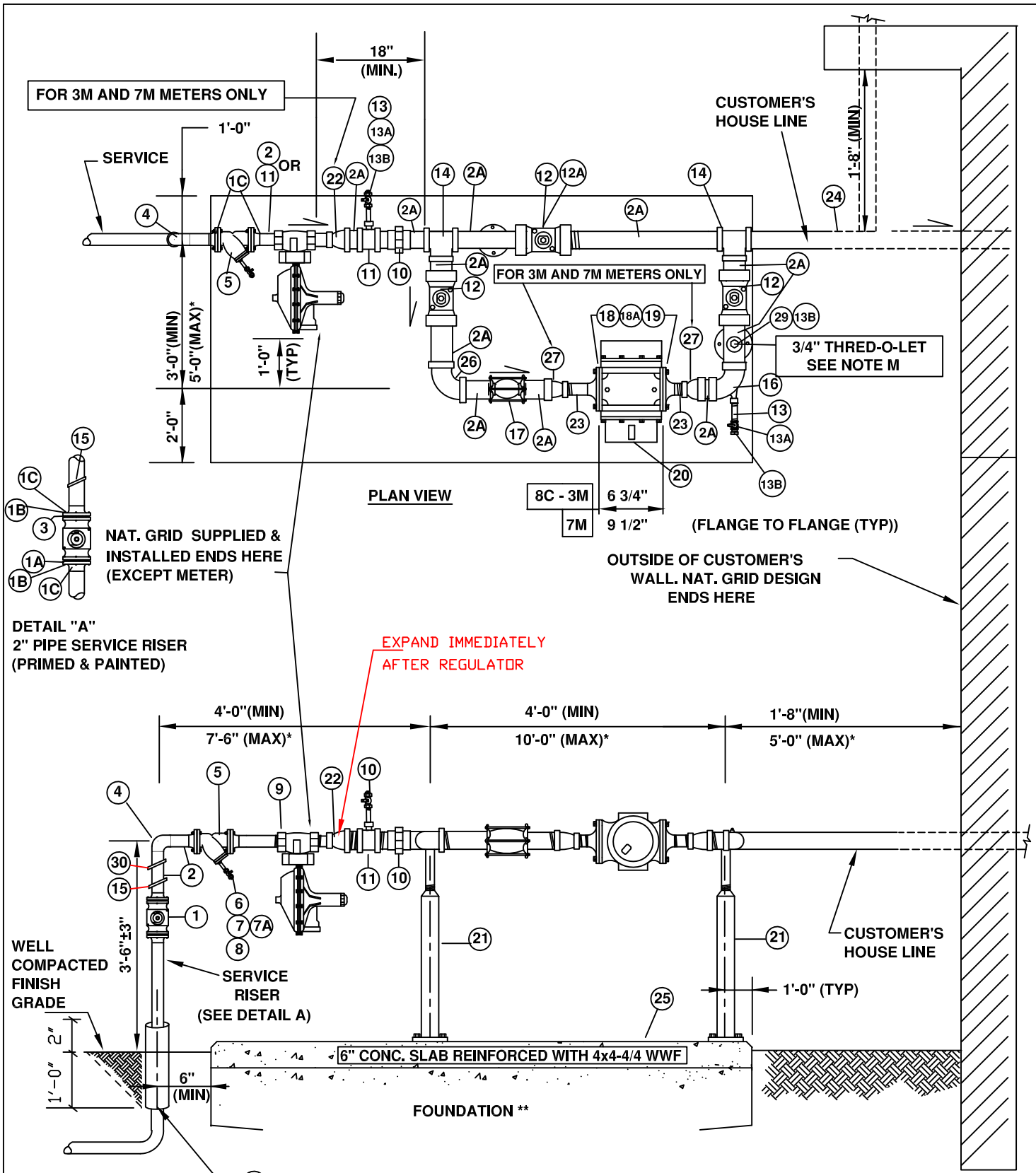
27	2" THREADED NIPPLE X 2" 150# FLAT FACE FLANGE	1	9383856
26	SLEEVE – 4" PIPE – PLASTIC OR EQUIVALENT	1	NAT. GRID
25	SLAB REINF – 4X4 – 4/4 WIRE WELDED FABRIC	1	X X
24	PIPE – HOUSE LINE	+	X X
23	CAP – 3" - THREADED	2	X X
22	PIPE SUPPORT – 2 1/2" – ADJUSTABLE SEE MTRS-6475	1	NAT. GRID
21	SYSTEM PRESSURE TAG	1	9346233
20	METER – LINE MOUNTED ROTARY – 3M 125 – 2" INLET / OUTLET	1	**
19	GASKET RING - METER	2	9341161
18A	BOLT – 5/8" X 2 ASTM A 307 GR B	8	9342411
18	FLANGE – 2" FF – COMPANION – ANSI CLASS 125 – THREADED OUTLET	2	X X
17	THREADOLET 3" X 3/4" SEE NOTE K	1	X X
16	GAS SNAPLOCK	2	9330915
14	COUPLING – 3" – COMPRESSION – DRESSER STYLE 38	1	X X
13B	PLUG – 3/4" - THREADED	3	X X
13A	NIPPLE – 3/4" X 3" - THREADED	2	X X
13	COCK – 3/4" - LOCKWING	2	X X
12A	LOCKING DEVICE	1	9330859
12	VALVE – 3" - THREADED	3	X X
11	CHANNEL – 1 5/8" - UNISTRUT W / CLAMP	+	X X
10	TEE – 3" - THREADED	4	X X
9,9A	ELBOW – 3" – 90 DEGREE - THREADED	5	X X
8	TEE – 3" X 3/4" X 3" - THREADED	2	X X
7,7A	REDUCER – 2" X 3" - THREADED	3	X X
6	UNION – 3"	2	X X
5	TAG – GAS SERVICE LOCATION	1	9340255
4	REGULATOR - 2" FISHER S-203 THREADED (NOTE THIS REGULATOR WAS DISCONTINUED 7/30/2012) REGULATOR - 2" ITRON B34IMRV - THREADED - 1/2" ORIFICE – 60 PSIG MAX. (3/8" REQ'D ON 99/124 SYS.) REGULATOR - 2" FISHER S-208 THREADED 1/2" ORIFICE – 100 PSIG MAX. (1/4" REQ'D ON 124 PSIG SYS.) REGULATOR - 2" FISHER CS-806 IR THREADED 1/2" ORIFICE – 100 PSIG MAX. (3/8" REQ'D ON 99/124 SYS.) REGULATOR - 2" FISHER CS-803 IT THREADED 5/8" ORIFICE – 60 PSIG MAX. (1/4" REQ'D ON 99/124 SYS.)	1 1	9383314 9342684 9342184 9386776 9386778
3	GASKET RING – 2"	1	9341161
2A	PIPE – 3"	+	X X
2	PIPE- 2"	+	9340729
1C	FLANGE – 2" – WELDED NECK	2	9341058
1B	BOLTS – 5/8" X 2 3/4" A 307 - MACHINE	8	9339766
1A	GASKET SET – 2" - INSTALLED	1	9340992
1	VALVE – 2" FLANGED	1	9341980

No.	ITEM	NAT. GRID ITEM ID	
<b>BILL OF MATERIAL – 3M METER</b>			

**NOTES**

- A. SEE GENERAL NOTES MTRS – 6545  
 B. ALL THREADED TYPE PIPE FITTINGS TO BE HOT DIPPED GALVANIZED  
 C. ALL FITTINGS SHALL BE MALLEABLE IRON CLASS 150, ANSI B 16.3  
 D. CINCH ANCHORS OR EQUIVALENT TO BE INSTALLED IN FLOOR FLANGE (ITEM 21) BY CUSTOMER  
 E. FOR UNDERGROUND CUSTOMER'S HOUSE PIPING REFER TO DESIGN SECTION  
 F. NAT. GRID WILL SUPPLY AND INSTALL ITEMS 1 THRU 5 (EXCEPT 2A) 12A, 16, 18A THRU 20 AND 26.  
 G. ITEM 4 AND 20 CAN BE ROTATED TO FIT FIELD CONDITIONS  
 H. THE CUSTOMER MAY AT HIS OPTION INSTALL A VERTICAL PRESSURE TAP AT ITEM 9A IF HEEL TEE IS USED.  
 I. INCREASE PIPE SIZE TO 3" WITHIN 12" OF THE REGULATOR.  
 J. FOR 99 PSIG AND 124 PSIG INLETS, THE ITRON B34IMRV MUST HAVE THE ORIFICE CHANGED TO 3/8". FOR 124, FISHER S-302 AND FISHER S-203 REGULATOR MUST HAVE THEIR ORIFICES CHANGED TO 1/4".  
 K. FOR T.C. RATE INSTALLATIONS AND METERING PRESSURES > 1 PSIG, A 3/4 THRED-O-LET IS NEEDED FOR A THERMOWELL. THIS MUST BE DRILLED OUT TO 7/8" DIAMETER.  
 AN ALTERNATE TO A THREADOLET IS A 3" X 2" THREADED TEE FOR 8C-3M INSTALLATIONS OR A 4" X 2" TEE FOR 7M INSTALLATIONS, THEN INSTALL A 2" X 3/4" BUSHING INTO THE TEE FOR THE THERMOWELL.  
 L. FOR 14" W.C. AND 1 PSIG METERING, CONTACT METER OPERATIONS FOR PROPER METER WITH INDEX.  
 LEGEND: X X SUPPLIED BY CUSTOMER \*\* TO BE SUPPLIED BY NATIONAL GRID + AS REQUIRED

27	2" THREADED NIPPLE X 2" 150# FLAT FACE FLANGE	1	9383856
26	SLEEVE – 4" PIPE – PLASTIC OR EQUIVALENT	1	NAT. GRID
25	SLAB REINF – 4X 4 – 4/4 WIRE WELDED FABRIC	1	X X
24	PIPE – HOUSE LINE	+	X X
23	CAP – 4" - THREADED	2	X X
22	PIPE SUPPORT – 3" – ADJUSTABLE	1	NAT. GRID *
21	SYSTEM PRESSURE TAG	1	9346233
20	METER – LINE MOUNTED ROTARY – 7M 125 – 3" INLET / OUTLET	1	**
19	GASKET RING - METER	2	9341162
18A	BOLT – 5/8" X 2" ASTM A 307 GR B	8	9342411
18	FLANGE – 3" FF – COMPANION – ANSI CLASS 125 – THREADED OUTLET	2	X X
17	THREADOLET 4" X 3/4" SEE NOTE K	1	X X
16	GAS SNAPLOCK	2	9330915
14	COUPLING – 4" – COMPRESSION – DRESSER STYLE 38	1	X X
13B	PLUG – 3/4" - THREADED	3	X X
13A	NIPPLE – 3/4" X 3" - THREADED	2	X X
13	COCK – 3/4" - LOCKWING	2	X X
12A	LOCKING DEVICE	1	9330859
12	VALVE – 4" - THREADED	3	X X
11	CHANNEL – 1 5/8" – UNISTRUT W / CLAMP	+	X X
10	TEE – 4" - THREADED	4	X X
9,9A	ELBOW – 4" – 90 DEGREE - THREADED	5	X X
8	TEE – 4" X 3/4" X 4" - THREADED	2	X X
7A	REDUCER – 3" X 4" - THREADED	2	X X
7	REDUCER – 2" X 4" - THREADED	1	X X
6	UNION – 4"	2	X X
5	TAG – GAS SERVICE LOCATION	1	9340255
4	REGULATOR - 2" FISHER S-203 THREADED (NOTE THIS REGULATOR WAS DISCONTINUED 7/30/2012) REGULATOR - 2" ITRON B34IMRV - THREADED - 1/2" ORIFICE – 60 PSIG MAX (3/8" REQ'D ON 99/124 SYS.) REGULATOR - 2" FISHER S-208 THREADED 1/2" ORIFICE – 100 PSIG MAX. (1/4" REQ'D ON 124 PSIG SYS.) REGULATOR - 2" FISHER CS-806 IR THREADED 1/2" ORIFICE – 100 PSIG MAX. (3/8" REQ'D ON 99/124 SYS.) REGULATOR - 2" FISHER CS-803 IT THREADED 5/8" ORIFICE – 60 PSIG MAX. (1/4" REQ'D ON 99/124 SYS.)	1	9383314 9342684 9342184 9386776 9386778
3	GASKET RING - 2"	1	9341161
2A	PIPE – 4"	+	X X
2	PIPE – 2"	+	9340729
1C	FLANGE – 2" – WELDED NECK	2	9341058
1B	BOLTS – 5/8" X 2 3/4", A 307 - MACHINE	8	9339766
1A	GASKET SET – 2" – FLANGED - INSULATED	1	9340992
1	VALVE – 2" - FLANGED	1	9341980
<b>No.</b>	<b>BILL OF MATERIAL ITEM – 7M</b>	<b>NAT. GRID CODE No.</b>	



**NOTES:**  
 \* MAX. DIMENSIONS FOR INFORMATION ONLY  
 \*\* SEE GENERAL NOTES

**nationalgrid**  
 LONG ISLAND

**HP MAIN / LP, 14" OR 1 PSIG METERING  
 FOR 8C, 1.5M, 3M OR 7M  
 HORIZONTAL - ROTARY GAS METER  
 OUTSIDE LOCATIONS**

<b>REVISIONS:</b> REVISED USING SAP ITEM ID #'S	DATE: 07/01/2003	EFFECTIVE DATE: 09/15/2013
	DESIGN: P.GUGLIOTTA	STD. DWG.
	DRAWN: P.GUGLIOTTA	NO. <b>MTRS-6265</b>

**NOTES**

- A. SEE GENERAL NOTES MTRS-6545
- B. ALL SCREW TYPE PIPE FITTINGS TO BE HOT DIPPED GALVANIZED
- C. ALL FITTINGS SHALL BE MALLEABLE IRON CLASS 150, ANSI B 16.3
- D. ALL EXPOSED UNCOATED PIPING SHALL BE COATED IN ACCORDANCE WITH 030030-TI
- E. CINCH ANCHORS TO BE INSTALLED IN FLOOR FLANGES (ITEM 21) BY CUSTOMER
- F. FOR UNDERGROUND CUSTOMER'S HOUSE PIPING REFER TO DESIGN SECTION
- G. FOR VEHICULAR DAMAGE PROTECTION SEE MTRS – 6060
- H. A METER SHALL NEVER BE INSTALLED LOWER THAN EITHER SIDE OF PIPE RUNS
- I. NAT. GRID WILL SUPPLY AND INSTALL ITEMS EXCEPT WHERE NOTED.
- J. THE CAPACITY OF THE S-302 WITH THE 7/32"X1/4" ORIFICE ON THE 60 PSIG SYSTEM IS 1500 CFH. ON THE 99/124 PSIG SYSTEM, A 5/32" X 3/16" ORIFICE IS NEEDED AND THE CAPACITY IS 2,900 CFH AND CAN BE USED FOR 3M INSTALLATIONS. FOR 7M INSTALLATIONS USE 2" ACTARIS B34IMRV OR FISHER S-203.
- K. **THE ACTARIS B-34IMRV, THE FISHER S-203 AND THE FISHER S-302 REGULATORS HAVE A MAXIMUM INLET PRESSURE OF 60 PSIG. FOR 99 PSIG AND 124 PSIG SYSTEMS, A 3/8" ORIFICE MUST BE INSTALLED.**
- L. FOR 14" AND 1 PSIG METERING, CONTACT METER OPERATIONS TO ORDER A 14" OR 1 PSIG INDEX AND THE METER.
- M. FOR T.C. RATE INSTALLATIONS AND METERING PRESSURES > 1 PSIG, A ¼ THRED-O-LET IS NEEDED FOR A THERMOWELL. THIS MUST BE DRILLED OUT TO 7/8" DIAMETER. AN ALTERNATE TO A THREDOLET IS A 2" X ¾" THREADED TEE FOR THE 8C AND 1.5M OR A 3" X 2" THREADED TEE FOR 3M INSTALLATIONS OR A 4" X 2" TEE FOR 7M INSTALLATIONS, THEN INSTALL A 2" X ¾" BUSHING INTO THE TEE FOR THE THERMOWELL.
- N. SEE NATIONAL GRID DRAWING 020013-CS FOR REGULATOR VENTING GUIDELINES.

**LEGEND**

- \*\* SUPPLIED BY CUSTOMER
- XX TO BE SUPPLIED BY METER OPERATIONS DEPARTMENT
- + AS REQUIRED

30	SYSTEM PRESSURE TAG	1	9346233	9346233	9346233
29	THREDOLET ¾" - SEE NOTE M	1	**	**	**
28	SLEEVE – 4" PIPE PLASTIC OR EQUIVALENT	1	NAT. GRID	NAT. GRID	NAT. GRID
27	REDUCER <b>(NOT NEEDED FOR 8C AND 1.5M)</b> . FOR 3M USE 3" X 2" , FOR 7M USE 4" X 3"	2	**	**	**
26	ELBOW – 90 3" (8C, 1.5M OR 3M) - OR 4" (7M) -	1	**	**	**
25	SLAB REINF 4 X4 – 4/4 WWF	1	**	**	**
24	PIPE – HOUSE LINE	+	**	**	**
23	PIPE 2" FOR 8C, 1.5M OR 3M, 3" FOR 7M	2	**	**	**
22	REDUCER <b>(NOT NEEDED FOR 8C AND 1.5M)</b> 3" X 2" FOR 3M, 4" X 2" FOR 7M	1	**	**	**
21	SADDLE – PIPE STANCHION – ADJUSTABLE	2	**	**	**
20	METER LINE MOUNTED ROTARY 8C, 1.5M, 3M OR 7M	1	XX	XX	XX
19	GASKET RING - METER	2	9341161	9341161	9341162
18A	BOLT, 5/8 – 11 X 2 ASTM A 307 GR B	8	9342411	9342411	9342411
18	FLANGE – COMPANION , ANSI CLASS 125 (2" FF FOR 8C, 1.5M OR 3M) OR (3" FF FOR 7M)	2	**	**	**
17	COUPLING COMPRESSION DRESSER STYLE 38 (2" FOR 8C & 1.5M, 3" FOR 3M, 4" FOR 7M)	1	**	**	**
16	HEEL TEE (2"X3/4"X2" FOR 8C & 1.5M, 3"X3/4"X3" FOR 3M OR (4" X 3/4" X 4" FOR 7M)	1	**	**	**
15	TAG CPR - GAS SERVICE LOCATION	1	9340255	9340255	9340255
14	TEE (2" FOR 8C & 1.5M, 3" FOR 3M OR 4" FOR 7M)	2	**	**	**
13B	PLUG, SOLID 3/4" NPT	3	**	**	**
13A	COCK, LOCKWING 3/4"	2	**	**	**
13	NIPPLE, 3/4" X 3" LONG	2	**	**	**
12A	LOCKING DEVICE	1	NAT. GRID	NAT. GRID	NAT. GRID
12	VALVE – (2" FOR 8C & 1.5M, 3" FOR 3M OR 4" FOR 7M)	3	**	**	**
11	TEE (8C, 1.5M) 2"X2"X3/4", (3M) 3" X 2" OR (7M) - 4" X 4" X 2" USE 2" X ¾" BUSHING	1	**	**	**
10	UNION 2" FOR 8C AND 1.5M, 3" FOR 3M OR 4" FOR 7M	1	**	**	**
9	2" FISHER S203 RELIEF / MONITOR REGULATOR SEE NOTE K	1	9383314	9383314	9383314
	2" ACTARIS B34IMRV SEE NOTE K	1	9342684	9342684	9342684
	2" FISHER S302 RELIEF OR B34SR / MONITOR REGULATOR (8C, 1.5M OR 3M ONLY) SEE NOTE J & K	1	9342660	9342660	N/A
	2" FISHER 8061R 100 PSIG MAX WITH ½" ORIFICE (3/8" ORIF NEEDED FOR 124 PSIG INLETS)	1	9386776	9386776	9386776
8	PLUG, SOLID 3/8" NPT	1	9340910	9340910	9340910
7A	GAS SNAP LOCK	1	9330915	9330915	9330915
7	COCK, LOCKWINMG 3/8"	1	9339744	9339744	9339744
6	NIPPLE, 3/8" X 3" LONG	1	9340616	9340616	9340616
5	STRAINER – CAST IRON, FLANGED END "Y" 100 MESH SCREEN W / BOLTS	1	9340158	9340158	9340158
4	ELBOW – 90 – 2"	1	9341213	9341213	9341213
3	GASKET – RING – 2"	3	9341161	9341161	9341161
2A	PIPE – (2" FOR 8C & 1.5M, 3" FOR 3M OR 4" FOR 7M)	+	**	**	**
2	PIPE – 2"	+	9340729	9340729	9340729
1C	FLANGE 2" WELDED NECK	4	9341058	9341058	9341058
1B	BOLTS 5/ 8 X 2 3/4 A 307	8	9339766	9339766	9339766
1A	GASKET FLANGED INSULATED, 2"	1	9340992	9340992	9340992
1	VALVE – FLANGE 2"	1	9341980	9341980	9341980

		QTY	8C OR 1.5M	3M	7M
--	--	-----	------------	----	----

No.	ITEM	NAT. GRID CODE No.		
<b>BILL OF MATERIAL</b>				

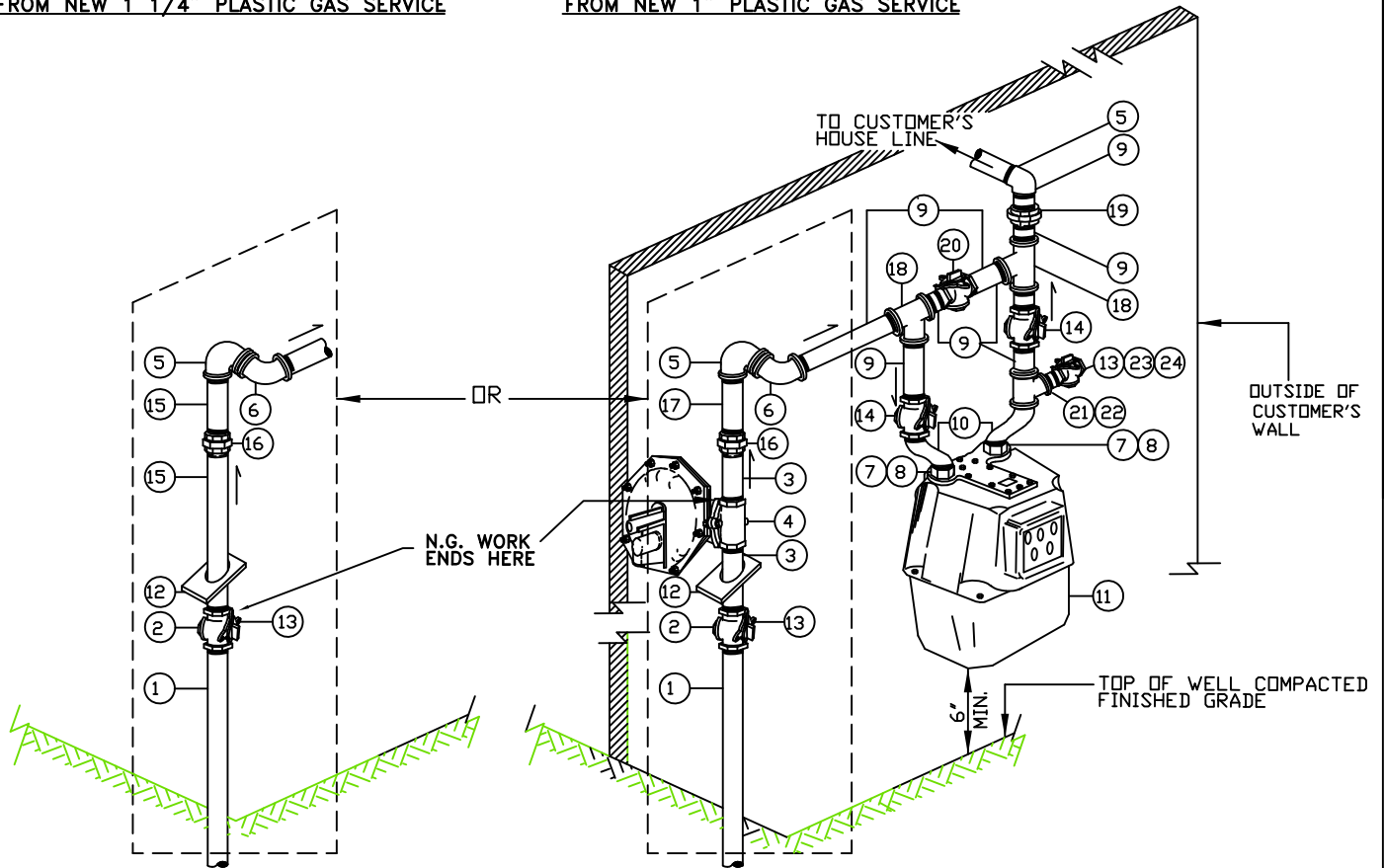
# CLASS 400 C.F.H. WITH BYPASS

## LOW PRESSURE

FROM NEW 1 1/4" PLASTIC GAS SERVICE

## HIGH PRESSURE

FROM NEW 1" PLASTIC GAS SERVICE



**nationalgrid**

LONG ISLAND

## OUTDOOR GAS METER CLASS 250 & 400 C.F.H. WITH BYPASS

**REVISIONS:** REVISED USING SAP ITEM ID #'S

DATE: 07/01/2003

EFFECTIVE DATE: 09/15/2013

DESIGN: JAL

STD. DWG.

DRAWN: MLoP

NO. **MTRS-6335**

**NOTES**

- A. THIS CONSTRUCTION STANDARD SHALL BE USED WHEN AN OUTDOOR METER SET IS SPECIFIED ON A WORK ORDER. METER SETS SHALL BE DESIGNED IN ACCORDANCE WITH THE CUSTOMER'S LOAD, SERVICE LENGTH AND SIZE AS OUTLINED IN DESIGN SECTION.
- B. A 3/4 INCH OR 1-1/4 INCH OUTLET RISER IS USED FOR THE METERS SHOWN.
- C. FOR SERVICE INSTALLATION REQUIREMENTS, REFER TO THE SERVICES SECTION STANDARDS. THE RISER SHALL BE LOCATED A MINIMUM OF 12 INCHES FROM THE OUTSIDE BUILDING FOUNDATION WALL.
- D. ALL EXPOSED PIPING AND THREADED FITTINGS SHALL BE GALVANIZED.
- E. AFTER PURGING THE SERVICE THE AND BEFORE INSTALLING THE METER. THE METER VALVE ON THE RISER AND THE BYPASS IF USED, SHALL BE CLOSED AND LOCKED WITH A GAS SNAP LOCK DEVICE.
- F. MAINTAIN 1/ 2 INCH MINIMUM CLEARANCE BETWEEN THE REGULATOR AND METER CASE OR ANY OTHER FOREIGN STRUCTURE. SWING REGULATOR, IF NECESSARY TO OBTAIN CLEARANCE.
- G. SERVICE RISER, METER HEADER AND METER SHALL BE LOCATED TO PREVENT DAMAGE BY VEHICLES AND MECHANICAL EQUIPMENT. WHERE A PROTECTED LOCATION IS NOT AVAILABLE, ADD ADDITIONAL PROTECTION BY USE OF CONCRETE FILLED STEEL POSTS. POST SHALL BE FURNISHED AND INSTALLED BY CONTRACTOR, PER KED STANDARD MTRS-6060.
- H. THE METER AND ASSOCIATED PIPING SHALL BE PLUMB AND LEVEL FROM BOTH THE FRONT AND SIDE AS SHOWN IN THE DRAWINGS BELOW.
- I. A STEEL PROTECTIVE SLEEVE SHALL BE USED AS A CASING FOR THE SERVICE PIPE WHEN INSTALLING THE SERVICE ABOVE GROUND THROUGH CONCRETE AND BLOCK WALLS. REFER TO SERV-6205 FOR LOCATIONS OF BUILDING ENTRY POINTS.
- J. UNLESS OTHERWISE SPECIFIED, ALL PIPING SHALL BE IN COMPLIANCE WITH N.F.P.A.-54 AND NATIONAL GRID'S SPECIFICATIONS AND REQUIREMENTS FOR GAS INSTALLATIONS.

A/R AS REQUIRED  
 N/R NOT REQUIRED  
 \* SUPPLIED BY KED  
 \*\* SUPPLIED AND INSTALLED BY CUSTOMER

CLASS 400 CFH <b>WITH</b> BYPASS		HIGH PRESSURE		LOW PRESSURE	
		QTY.	ITEM ID	QTY.	ITEM ID
24	PLUG 3/4" STEEL SOLID	1	**	1	**
23	VALVE 3/4" LOCKWING, GALVANIZED	1	**	1	**
22	NIPPLE 3/4" X 2" LONG, SCH. 40, GALVANIZED	1	**	1	**
21	TEE 1-1/4" X 3/4", THREADED, GALVANIZED	1	**	1	**
20	METER VALVE - LOCKWING	1	**	1	**
19	UNION - 1 1/4" - NON- INSULATED	1	**	1	**
18	TEE - 1 1/4"	2	**	2	**
17	PIPE - 1 1/4" - STEEL - GALV.	A / R	**	A / R	**
16	UNION - 1 1/4" - INSULATING	1	9341691**	1	9341691**
15	NIPPLE - 1 1/4" X 12"	-	N / R	2	9340657**
14	VALVE - METER - 1 1/ 4"	2	**	2	**
13	GAS SNAP LOCK	1	9330915*	1	9330915*
12	TAG - GAS SERVICE LOCATION	1	9340255*	1	9340255*
11	METER - TEMPERATURE COMPENSATED	1	*	1	*
10	SWIVEL - METER - 1 1/4"	2	9342425*	2	9342425*
9	NIPPLE - 1 1/4" X LENGTH AS REQUIRED	7	**	7	**
8	SWIVEL WASHER - RUBBER	2	9342480*	2	9342480*
7	NUT - METER - 45 LIGHT	2	9340788*	2	9340788*
6	ELBOW - 1 1/4" - STREET	1	**	1	**
5	ELBOW - 1 1/4" - SCREW	2	**	2	**
4	REGULATOR - 1 1/4" FOR 60 PSIG SYSTEM MAXIMUM 3/8" ORIFICE REGULATOR - 1 1/4" FOR 99 PSIG AND 124 PSIG SYSTEMS 1/2" ORIFICE	1	9342206* 9383127*	-	N / R
3	NIPPLE - 1 1/4" X 4"	2	9340652**	-	N / R
2	METER VALVE- 1 1/4" - LOCKING	1	9339609*	1	9339609*
1	RISER - 1" CTS X 1- 1/4" OUTLET RISER - 1-1/4" IPS X 1-1/4" OUTLET	1 -	9340874* -	- 1	- 9340941*

No.	ITEM	SAP ITEM ID
-----	------	-------------

**BILL OF MATERIAL**

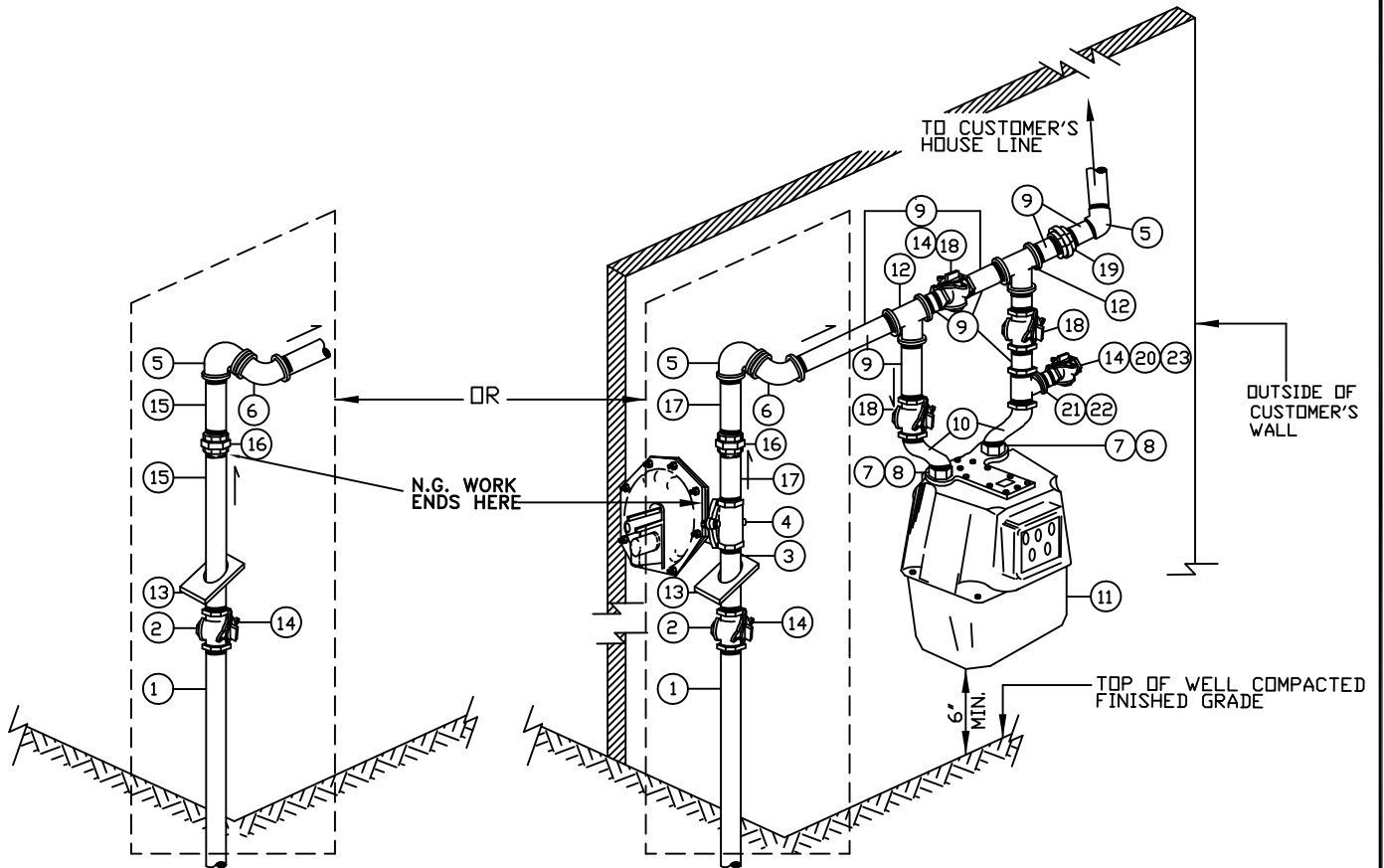
# CLASS 250 C.F.H. WITH BYPASS

## LOW PRESSURE

FROM NEW 1 1/4" PLASTIC GAS SERVICE

## HIGH PRESSURE

FROM NEW 1/2" OR 1" PLASTIC GAS SERVICE





**NOTES**

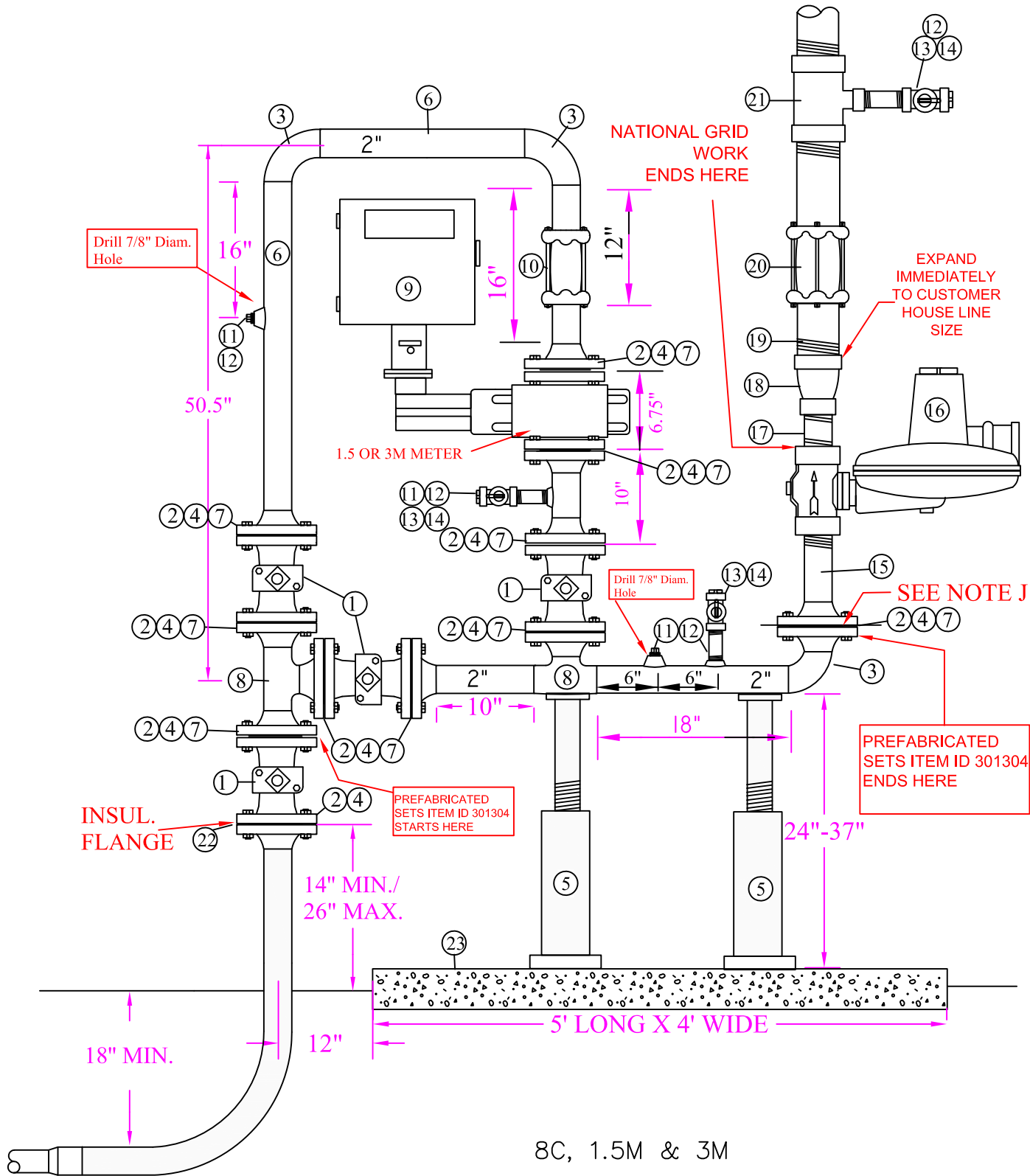
- A. THIS CONSTRUCTION STANDARD SHALL BE USED WHEN AN OUTDOOR METER SET IS SPECIFIED ON A WORK ORDER. METER SETS SHALL BE DESIGNED IN ACCORDANCE WITH THE CUSTOMER'S LOAD, SERVICE LENGTH AND SIZE AS OUTLINED IN DESIGN SECTION.
- B. A 3/4 INCH OR 1-1/4 INCH OUTLET RISER IS USED FOR THE METERS SHOWN.
- C. FOR SERVICE INSTALLATION REQUIREMENTS, REFER TO THE SERVICES SECTION STANDARDS. THE RISER SHALL BE LOCATED A MINIMUM OF 12 INCHES FROM THE OUTSIDE BUILDING FOUNDATION WALL.
- D. ALL EXPOSED PIPING AND THREADED FITTINGS SHALL BE GALVANIZED OR BLACK AND PRIMED AND PAINTED.
- E. AFTER PURGING THE SERVICE THE AND BEFORE INSTALLING THE METER. THE METER VALVE ON THE RISER AND THE BYPASS IF USED, SHALL BE CLOSED AND LOCKED WITH A GAS SNAP LOCK DEVICE.
- F. MAINTAIN 1/2 INCH MINIMUM CLEARANCE BETWEEN THE REGULATOR AND METER CASE OR ANY OTHER FOREIGN STRUCTURE. SWING REGULATOR, IF NECESSARY TO OBTAIN CLEARANCE.
- G. SERVICE RISER, METER HEADER AND METER SHALL BE LOCATED TO PREVENT DAMAGE BY VEHICLES AND MECHANICAL EQUIPMENT. WHERE A PROTECTED LOCATION IS NOT AVAILABLE, ADD ADDITIONAL PROTECTION BY USE OF CONCRETE FILLED STEEL POSTS. POST SHALL BE FURNISHED AND INSTALLED BY CONTRACTOR, PER KED STANDARD MTRS-6060.
- H. THE METER AND ASSOCIATED PIPING SHALL BE PLUMB AND LEVEL FROM BOTH THE FRONT AND SIDE AS SHOWN IN THE DRAWINGS BELOW.
- I. A STEEL PROTECTIVE SLEEVE SHALL BE USED AS A CASING FOR THE SERVICE PIPE WHEN INSTALLING THE SERVICE ABOVE GROUND THROUGH CONCRETE AND BLOCK WALLS. REFER TO SERV-6205 FOR LOCATIONS OF BUILDING ENTRY POINTS.
- J. UNLESS OTHERWISE SPECIFIED, ALL PIPING SHALL BE IN COMPLIANCE WITH N.F.P.A.-54 AND NATIONAL GRID'S SPECIFICATIONS AND REQUIREMENTS FOR GAS INSTALLATIONS.


A/R AS REQUIRED  
 N/R NOT REQUIRED  
 \* SUPPLIED BY KED  
 \*\* SUPPLIED BY CUSTOMER

CLASS 250 <b>WITH</b> BYPASS		HIGH PRESSURE		LOW PRESSURE	
		QTY.	ITEM ID	QTY.	ITEM ID
23	PLUG,3/4" STEEL SOLID	1	**	1	**
22	TEE 1" X 3/4", THREADED, GALVANIZED	1	**	1	**
21	NIPPLE 3/4" X 2" LONG GALVANIZED, SCH. 40	1	**	1	**
20	VALVE 3/4" LOCK WING, GALVANIZED	1	**	1	**
19	UNION – INSULATING 1"	1	**	-	-
	UNION – INSULATING 1-1/4"	-	-	1	**
18	VALVE 1" LOCKWING, GALVANIZED	3	**	2	**
	VALVE 1-1/4" LOCKWING, GALVANIZED	-	-	1	**
17	NIPPLE 1" X 6"	2	**	-	**
16	UNION – INSULATING 1"	1	9341684**	-	-
	UNION – INSULATING 1-1/4"	-	-	1	9341685**
15	NIPPLE -1 1/4" X LENGTH AS REQUIRED	3	N/R	1	9341197**
14	GAS SNAP LOCK	2	9330915**	2	9330915**
13	TAG-GAS SERVICE LOCATION	1	9340255*	1	9340255*
12	TEE 1" X 1" X 1" GALV. SCREW	2	**	-	-
	TEE 1-1/4" X 1-1/4" X 1" GALV. SCREW	-	-	2	**
11	METER-TEMPERATURE COMPENSATED	1	*	1	*
10	SWIVEL-METER-1" X 20 LT WITH 1 5/8" OFFSET	2	9383109*	2	9383109*
9	NIPPLE-1" X LENGTH AS REQUIRED	7	**	-	**
	NIPPLE – 1-1/4" X LENGTH AS REQUIRED	-	**	7	**
8	WASHER-METER NUT	2	9342478	2	9342478
7	NUT-METER – 20 LIGHT	2	9340787	2	9340787
6	ELBOW – 1" – STREET	1	9341192**	-	-
	ELBOW – 1-1/4" - STREET	-	-	1	9341193**
5	ELBOW – 1" – SCREW	2	9341181**	-	-
	ELBOW 1-1/4" - SCREW	-	-	2	9341185**
4	REGULATOR – 3/4" X 1"	1	9383047*	-	N/R
3	NIPPLE – 3/4" X 4"	1	9340633*	-	N/R
2	METER VALVE – 3/4" – LOCKING	1	9339593*	-	-
	METER VALVE – 1/1/4" - LOCKING	-	-	1	9339609*
1	RISER PIPE 1/2" MEDIUM DENSITY X 3/4" STEEL	1	9340875*	-	-
	RISER PIPE 1/2" HIGH DENSITY X 3/4" STEEL	1	9340852*	-	-
	RISER 1-1/4" IPS MEDIUM DENSITY X 1-1/4" STEEL	-	-	1	9340941*

No.	ITEM	SAP ITEM ID
-----	------	-------------

**BILL OF MATERIAL**



	<b>8C, 1.5, 3M &amp; 7M HIGH PRESSURE ROTARY METER, VERTICAL POSITION WITH SINGLE REGULATOR</b>	
	DATE: 07/01/2003 DESIGN: PAUL GUGLIOTTA DRAWN: PAUL GUGLIOTTA	EFFECTIVE DATE: 09/15/2013 STD. DWG. NO. MTRS-6385
REVISIONS: REVISED USING SAP ITEM ID #'S		

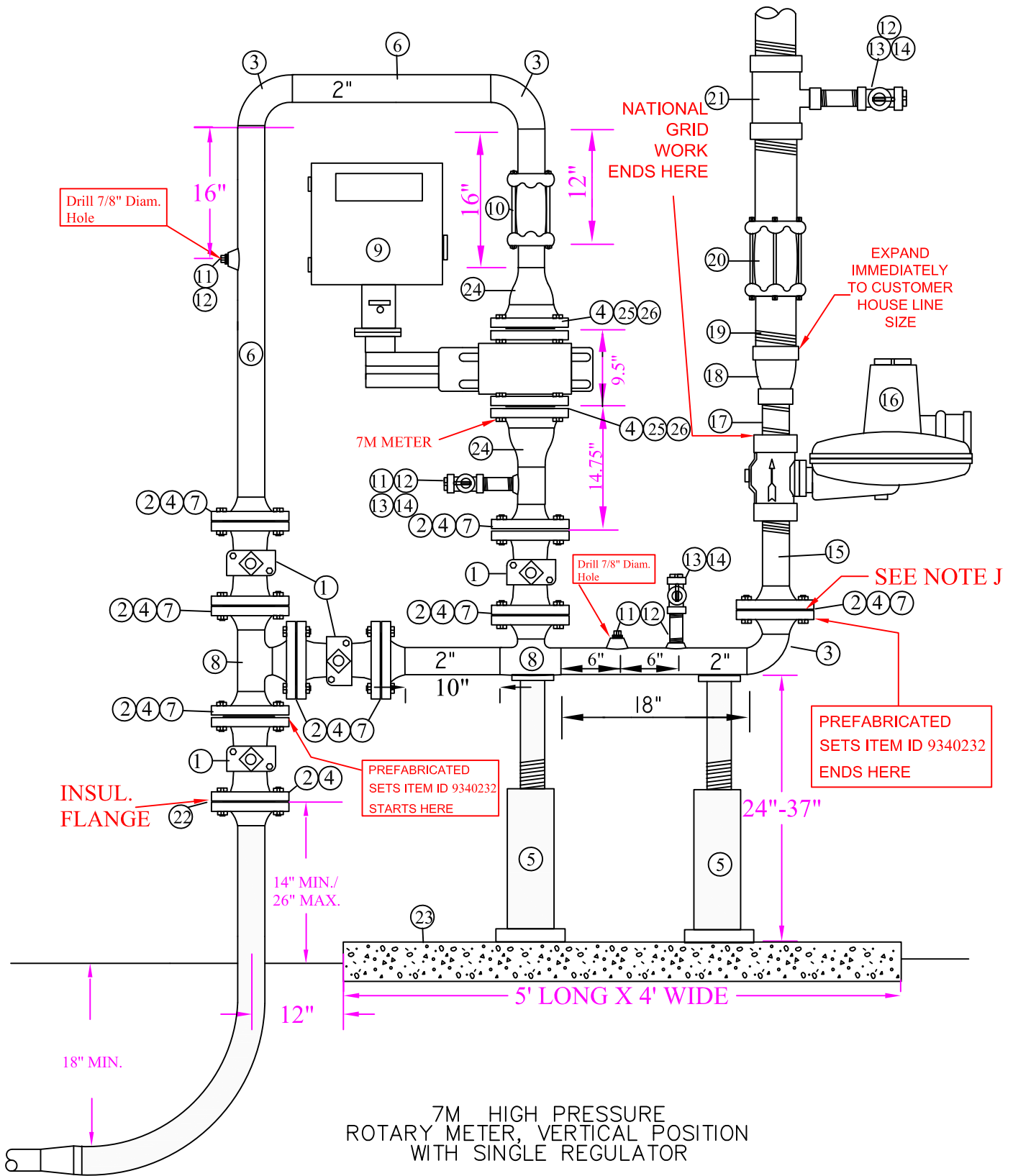
**INSTALLATION NOTES**

- A. FOR 99 AND 124 PSIG SERVICES, THE ITRON B-34 IMRV REGULATOR OR THE FISHER S-203 AND S-302 REGULATOR MUST HAVE THE ORIFICE CHANGED TO 3/8". THE ITRON B34IMRV AND FISHER S-302 AND S-203 REGULATOR HAVE INTERNAL MONITORS WHICH SERVE AS OVER PRESSURE PROTECTION. ALL OTHER REGULATORS (SUCH AS FISHER S-201 AND 133 SERIES) MUST USE SEPARATE RELIEF VALVES FOR OVER PROTECTION. FISHER 133 AND S-203P REQUIRE DOWNSTREAM CONTROL LINESS. FOR THESE AND OTHER REMOTE MONITORING REGULATORS, INSTALL 3/4" STEEL CONTROL LINE 10 PIPE DIAMETERS OF CUSTOMER'S HOUSE LINE (10 PIPE DIAMETER STARTS AFTER THE REDUCER - ITEM 18). MAXIMUM CAPACITY OF A FISHER S-302 IS 1500 CFH ON THE 60 SYSTEM.
- B. GALVANIZED PIPE AND FITTINGS ARE THE PREFERRED MATERIALS OF CHOICE. BLACK PIPE, PRIMED AND PAINTED IS ALSO ACCEPTABLE.
- C. WHERE VEHICLE TRAFFIC IS A CONCERN, PROTECTION POST ARE REQUIRED. REFER TO APPROVED KEYSpan PROTECTION POST STANDARDS.
- D. DO NOT WELD METER IN PLACE. USE A SPOOL PIECE.
- E. ALL WELDING MUST CONFORM TO API-1104 PROCEDURES. ALL PIPING SHALL BE TESTED AT 1.5 MAOP OF INLET SERVICE PRESSURE FOR 30 MINUTES.
- F. PREFABRICATED METER SETS COME WITH 2" X 6-3/4" LONG SPOOL PIECE IN PLACE OF METER.
- G. 2" STRAINERS (ITEM ID 9340258) AND FILTERS (ITEM ID 9341258) CAN BE USED TO PROTECT EQUIPMENT FROM IN LINE DEBRIS. FOR PREFABRICATED SETS USE A FLANGED ELBOW (ITEM ID 9383780) AND ROTATE FLANGED TEE AFTER INLET VALVE FOR STRAINER/FILTER INSTALLATION. SEE FIGURE 2 ON PAGE 9.
- H. FOR PREFABRICATED SETS THAT REQUIRE DUAL RATES, INSTALL FLANGED TEE ON THE RISER VALVE AND THEN ROTATE FLANGED TEE ON THE PREFABRICATED SET FOR THE SECOND METER HEADER. SEE FIG 1 ON PAGE 9.
- I. ELEVATED PRESSURE SHALL BE ONLY USED IF CUSTOMER'S EQUIPMENT REQUIRES IT. IT WILL NOT BE APPROVED TO DOWNSIZE HOUSE LINE.
- J. THIS FLANGE SET IS ONLY FOR PREFABRIACTED METER HEADERS. IF THIS HEADER IS BEING BUILT NEW, THESE TWO FLANGES ARE NOT NEEDED.

**BILL OF MATERIAL**

ITEM	DESCRIPTION	ITEM I.D	QTY	MATERIAL NOTES
1	VALVE – 2" PLUG NODSTROM FIG 143	9341980	4	FLANGED ENDS PER ASTM A-105 GR. B OR A-350 LF-2 STD. WALL PER A-234 WPB
2	FLANGE 2" WELD NECK FLAT FACE	9341058	11	
3	ELBOW 2" WELD END 90 DEG. LONG RADIUS	9341213	3	
4	BOLTS MACHINE – 5/8" X 2-3/4" W/2H HEX NUT	9339766	44	
5	PIPE SUPPORTS SADDLE – (TOP SECTION ONLY)	9339861	2	
	PIPE SUPPORT BASE 20"-25" HEIGHT (BOTTOM SECT)	9323172	2	INCLUDED IN PREFABRICATED SET SEE MTRS-6475 FOR PIPE SUPPORTS CHOOSE THE BASE WHICH WILL DETERMINE THE OVERALL LENGTH OF THE SUPPORT (FROM GROUND TO BOTTOM OF PIPE)
	PIPE SUPPORT BASE 26"-31" HEIGHT (BOTTOM SECT)	9339886	2	
	PIPE SUPPORT BASE 32"-41" HEIGHT (BOTTOM SECT)	9339885	2	
6	PIPE 2" STD. WALL (SCH. 40)	9340729	15'	
7	GASKET 2" FULL FACE FOR 150# FF FLANGE	9341161	10	KLINGER NITRILE TYPE C-4401
8	TEE 2", WELD END STD. WALL PER A-234 WPB	9342462	2	ALT. IN 1 LOCATION, USE FLANGED TEE 371139
9	METER 8C, 1.5M OR 3M TEMPERATURE CORRECTED	+	1	
10	COUPLING 2" LOCK TYPE	9341621	1	
11	THRED-O-LET 3/4" X 2" PIPE	9341652	4	PER A-105 GRADE B
12	PLUG 3/4" SOLID STEEL	9340912	4	3 BY KEYSpan/1 BY CUSTOMER
13	NIPPLE 3/4" X 3" LONG, GALVANIZED	9340631	3	2 BY KEYSpan/1 BY CUSTOMER
14	VALVE 3/4" LOCKWING, GALVANIZED TAMPER PROOF	9339593	3	2 BY KED/1 BY CUST. – AY McDONALD 525B
15	THREADED 2" NIPPLE X 2" FLAT FACE 150# FLANGE	9383856	1	ALT USE ITEM 2 AND 6 AND THREAD ONE END
16	2" FISHER S302 OR B34SR (1,100 CFH MAX) OR 2" FISHER S203 RELIEF MONITOR REGULATOR OR 2" B34IMRV RELIEF / MONITOR REGULATOR 2" FISHER CS-806IR 1/2" ORIF. (100 PSIG MAX WITH 1/2" ORIF, FOR 124 PSIG INLET 3/8" ORIF. REQ'D) 2" FISHER CS-803IR 5/8" ORIF. 60. PSIG MAX 2" FISHER CS-806IR 7/8" ORIF. 50 PSIG MAX.  SPRING FOR FISHER S203 - 14" SET POINT (8.5" – 18" GRAY) ITEM ID 9342699 SPRING FOR FISHER S203 - 1 PSIG (28") SET POINT (14" – 30" DARK GREEN) ITEM ID 9342194 SPRING FOR ACTARIS B34IMRV – 14" AND 28" SET POINT 11.5" – 28" SP. RANGE – BLUE) ITEM ID 9342636 SPRING FOR FISHER CS-806 14" – 30" GREEN 9386657 SPRING FOR FISHER CS-806 1 PSIG – 2.25 PSIG BLUE 9386658 SPRING FOR FISHER CS-806 2.5 PSIG – 5.5 PSIG YELLOW 9386658	9342660 9383314 9342684 9386776 9386778 9386779	1	<b>SEE NOTE A</b>
17	NIPPLE 2" X 4" LONG GALVANIZED STD. WT	BY CUST.	1	
18	REDUCER 2" X CUST. HOUSE LINE SIZE GLAV.	BY CUST.	1	
19	PIPE – CUST. HOUSE LINE SIZE. GALVANIZED	BY CUST	A/R	
20	COUPLING CUSTOMER HOUSE LINE SIZE LOCK TYPE	BY CUST	1	
21	TEE CUST. HOUSE LINE SIZE X 3/4", THREADED, GALV.	BY CUST.	1	
22	INSULATING FLANGE KIT	9340992	1	
23	METER PAD 5' LONG X 4' WIDE X 6" THICK	BY CUST.	1	

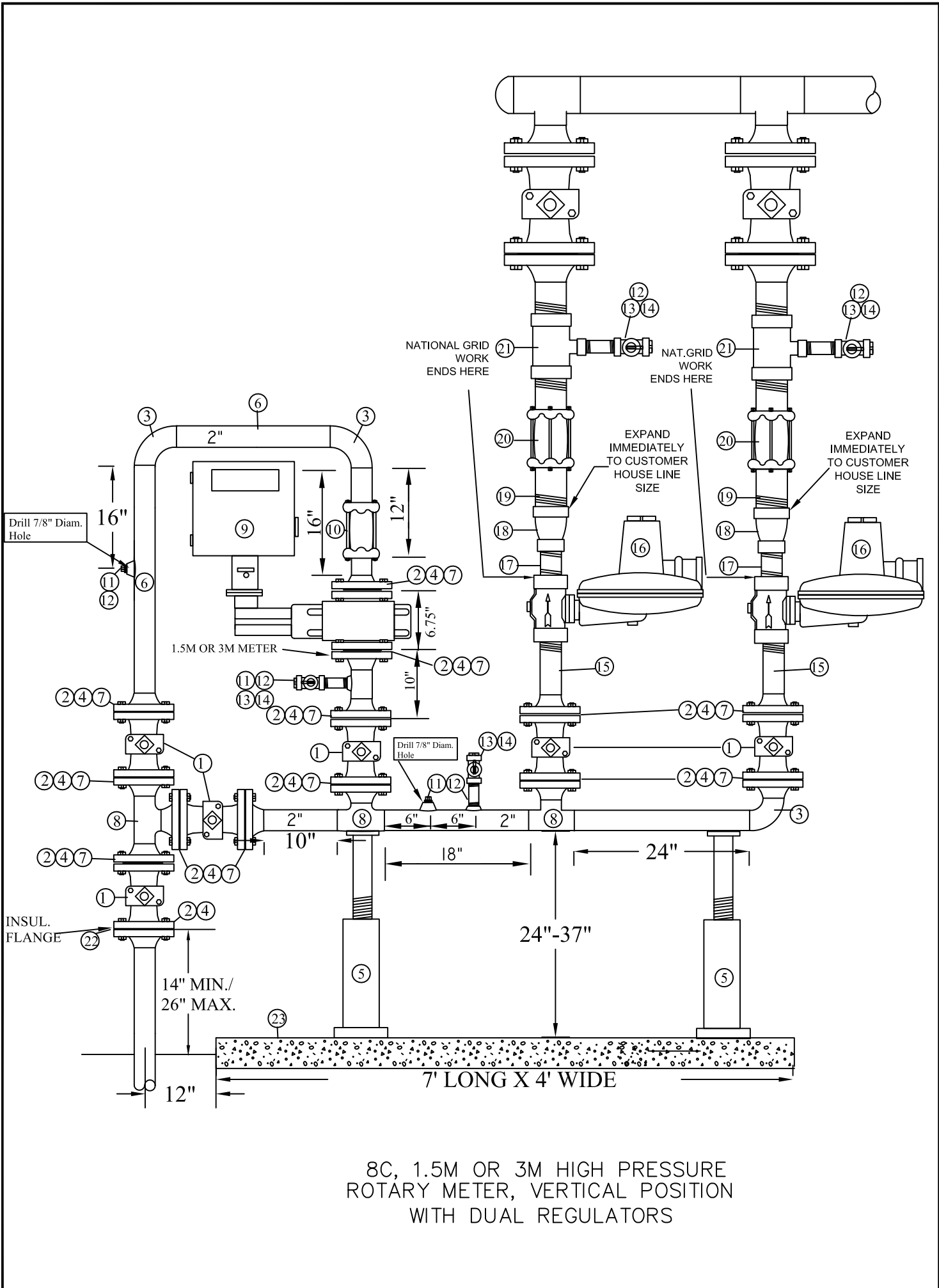
**BILL OF MATERIAL**



**INSTALLATION NOTES**

- A. FOR 99 AND 124 PSIG SERVICES, THE ITRON B-34 IMRV REGULATOR OR THE FISHER S-203 AND S-302 REGULATOR MUST HAVE THE ORIFICE CHANGED TO 3/8". THE ITRON B34IMRV AND FISHER S-302 AND S-203 REGULATOR HAVE INTERNAL MONITORS WHICH SERVE AS OVER PRESSURE PROTECTION. ALL OTHER REGULATORS (SUCH AS FISHER S-201 AND 133 SERIES) MUST USE SEPARATE RELIEF VALVES FOR OVER PROTECTION. FISHER 133 AND S-203P REQUIRE DOWNSTREAM CONTROLS. FOR THESE AND OTHER REMOTE MONITORING REGULATORS, INSTALL 3/4" STEEL CONTROL LINE 10 PIPE DIAMETERS OF CUSTOMER'S HOUSE LINE (10 PIPE DIAMETER STARTS AFTER THE REDUCER - ITEM 18).
- B. GALVANIZED PIPE AND FITTINGS ARE THE PREFERRED MATERIALS OF CHOICE. BLACK PIPE, PRIMED AND PAINTED IS ALSO ACCEPTABLE.
- C. WHERE VEHICLE TRAFFIC IS A CONCERN, PROTECTION POST ARE REQUIRED. REFER TO APPROVED KEYSpan PROTECTION POST STANDARDS.
- D. DO NOT WELD METER IN PLACE. USE A SPOOL PIECE.
- E. ALL WELDING MUST CONFORM TO API-1104 PROCEDURES. ALL PIPING SHALL BE TESTED AT 1.5 MAOP OF INLET SERVICE PRESSURE FOR 30 MINUTES.
- F. PREFABRICATED METER SETS COME WITH 2" X 6-3/4" LONG SPOOL PIECE IN PLACE OF METER.
- G. 2" STRAINERS (ITEM ID 9340158) AND FILTERS (ITEM ID 9341258) CAN BE USED TO PROTECT EQUIPMENT FROM IN LINE DEBRIS. FOR PREFABRICATED SETS USE A FLANGED ELBOW (ITEM ID 9383780) AND ROTATE FLANGED TEE AFTER INLET VALVE FOR STRAINER/FILTER INSTALLATION. SEE FIGURE 2 ON PAGE 9.
- H. FOR PREFABRICATED SETS THAT REQUIRE DUAL RATES, INSTALL FLANGED TEE ON THE RISER VALVE AND THEN ROTATE FLANGED TEE ON THE PREFABRICATED SET FOR THE SECOND METER HEADER. SEE FIG 1 ON PAGE 9.
- I. ELEVATED PRESSURE SHALL BE ONLY USED IF CUSTOMER'S EQUIPMENT REQUIRES IT. IT WILL NOT BE APPROVED TO DOWNSIZE HOUSE LINE.
- J. THIS FLANGE SET IS ONLY FOR PREFABRIACTED METER HEADERS. IF THIS HEADER IS BEING BUILT NEW, THESE TWO FLANGES ARE NOT NEEDED.

ITEM	DESCRIPTION	ITEM I.D	QTY	MATERIAL NOTES
1	VALVE – 2" PLUG NODSTROM FIG 143	9341980	4	FLANGED ENDS
2	FLANGE 2" WELD NECK FLAT FACE	9341058	11	PER ASTM A-105 GR. B OR A-350 LF-2
3	ELBOW 2" WELD END 90 DEG. LONG RADIUS	9341213	3	STD. WALL PER A-234 WPB
4	BOLTS MACHINE – 5/8" X 2-3/4" W/2H HEX NUT	9339766	44	
5	PIPE SUPPORTS SADDLE – (TOP SECTION ONLY)	9339861	2	INCLUDED IN PREFABRICATED SET
	PIPE SUPPORT BASE 20"-25" HEIGHT (BOTTOM SECT)	9323172	2	SEE MTRS-6475 FOR PIPE SUPPORTS
	PIPE SUPPORT BASE 26"-31" HEIGHT (BOTTOM SECT)	9339886	2	CHOOSE THE BASE WHICH WILL DETERMINE
	PIPE SUPPORT BASE 32"-41" HEIGHT (BOTTOM SECT)	9339885	2	THE OVERALL LENGTH OF THE SUPPORT (FROM GROUND TO BOTTOM OF PIPE)
6	PIPE 2" STD. WALL (SCH. 40)	9340729	15'	PER A-106 GR. B
7	GASKET 2" FULL FACE FOR 150# FF FLANGE	9341161	10	KLINGER NITRILE TYPE C-4401
8	TEE 2", WELD END STD. WALL PER A-234 WPB	9342462	2	ALT. IN 1 LOCATION, USE FLANGED TEE 371139
9	METER 7M TEMPERATURE CORRECTED	+	1	
10	COUPLING 2" LOCK TYPE	9341621	1	
11	THRED-O-LET 3/4" X 2" PIPE	9341652	4	PER A-105 GRADE B
12	PLUG 3/4" SOLID STEEL	9340912	4	3 BY KEYSpan/1 BY CUSTOMER
13	NIPPLE 3/4" X 3" LONG, GALVANIZED	9340631	3	2 BY KEYSpan/1 BY CUSTOMER
14	VALVE 3/4" LOCKWING, GALVANIZED TAMPER PROOF	9339593	3	2 BY KED/1 BY CUST. – AY McDONALD 525B
15	THREADED 2" NIPPLE X 2" FLAT FACE 150# FLANGE	9383856	1	ALT USE ITEM 2 AND 6 AND THREAD ONE END
16	2" FISHER S302 OR B34SR (1,100 CFH MAX) OR 2" FISHER S203 RELIEF MONITOR REGULATOR OR 2" B34IMRV RELIEF / MONITOR REGULATOR 2" FISHER CS-806IR 1/2" ORIF. (100 PSIG MAX WITH 1/2" ORIF, FOR 124 PSIG INLET 3/8" ORIF. REQ'D) 2" FISHER CS-803IR 5/8" ORIF. 60. PSIG MAX 2" FISHER CS-806IR 7/8" ORIF. 50 PSIG MAX.  SPRING FOR FISHER S203 - 14" SET POINT (8.5" – 18" GRAY) ITEM ID 9342699 SPRING FOR FISHER S203 - 1 PSIG (28") SET POINT (14" – 30" DARK GREEN) ITEM ID 9342194 SPRING FOR ACTARIS B34IMRV – 14" AND 28" SET POINT 11.5" – 28" SP. RANGE – BLUE) ITEM ID 9342636 SPRING FOR FISHER CS-806 14" – 30" GREEN 9386657 SPRING FOR FISHER CS-806 1 PSIG – 2.25 PSIG BLUE 9386658 SPRING FOR FISHER CS-806 2.5 PSIG – 5.5 PSIG YELLOW 9386658	9342660 9383314 9342684 9386776  9386778 9386779	1	
17	NIPPLE 2" X 4" LONG GALVANIZED STD. WT	BY CUST.	1	
18	REDUCER 2" X CUST. HOUSE LINE SIZE GLAV.	BY CUST.	1	
19	PIPE – CUST. HOUSE LINE SIZE. GALVANIZED	BY CUST.	1	
20	COUPLING CUSTOMER HOUSE LINE SIZE LOCK TYPE	BY CUST.	1	
21	TEE CUST. HOUSE LINE SIZE X 3/4", THREADED, GALV.	BY CUST.	1	
22	INSULATING FLANGE KIT	9340992	1	
23	METER PAD 5' LONG X 4' WIDE X 6" THICK	BY CUST.	1	
24	REDUCER 3" X 2" CONCENTRIC, WELD END	9342651	2	
25	FLANGE 3" WELD NECK FLAT FACE 150# STD.BORE	9341388	2	
26	GASKET 3" FULL FACE 1/16" THICK	9341158	2	

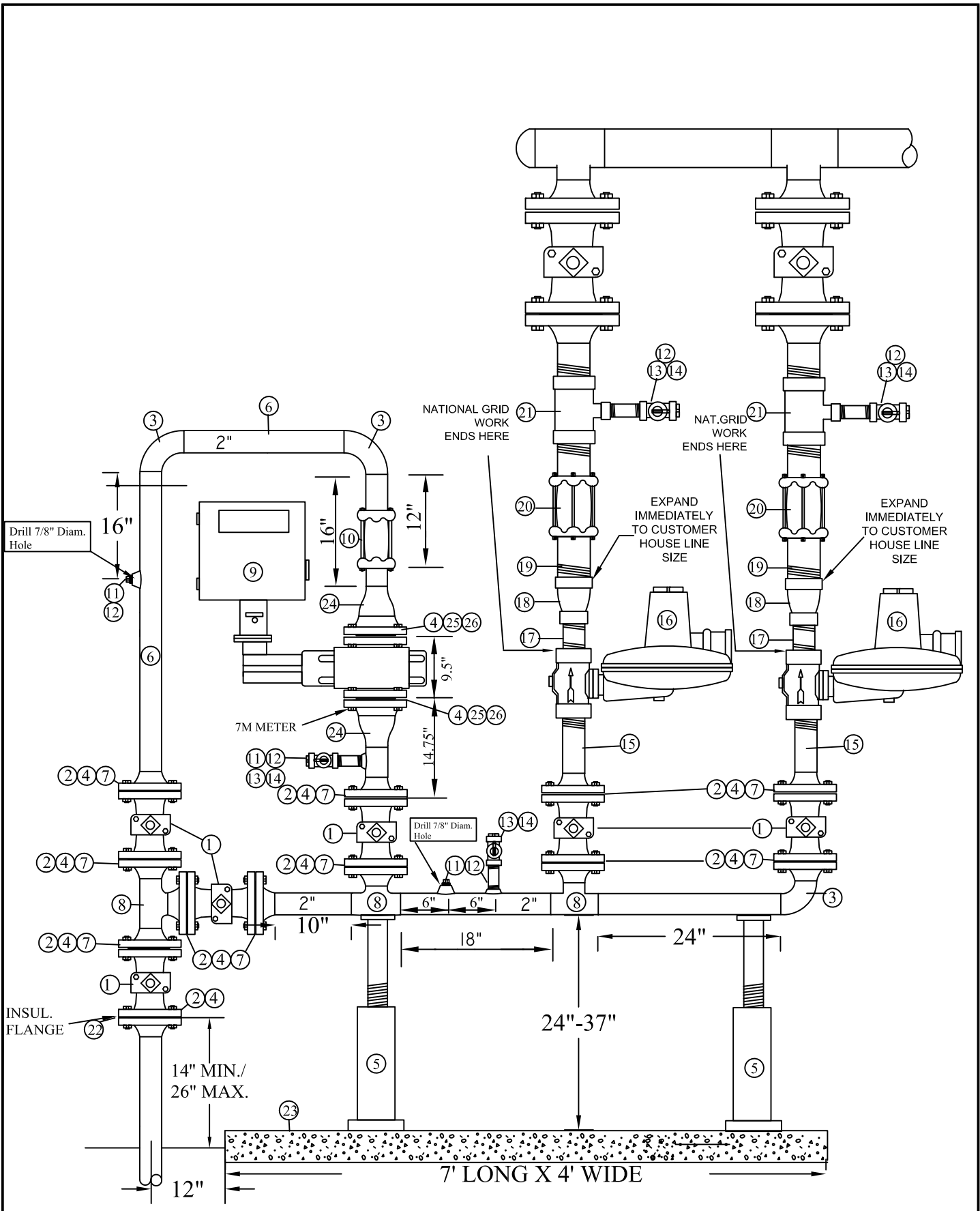


**INSTALLATION NOTES**

- A. FOR 99 AND 124 PSIG SERVICES, THE ITRON B-34 IMRV REGULATOR OR THE FISHER S-203 AND S-302 REGULATOR MUST HAVE THE ORIFICE CHANGED TO 3/8". THE ITRON B34IMRV AND FISHER S-302 AND S-203 REGULATOR HAVE INTERNAL MONITORS WHICH SERVE AS OVER PRESSURE PROTECTION. ALL OTHER REGULATORS (SUCH AS FISHER S-201 AND 133 SERIES) MUST USE SEPARATE RELIEF VALVES FOR OVER PROTECTION. FISHER 133 AND S-203P REQUIRE DOWNSTREAM CONTROL LINESS. FOR THESE AND OTHER REMOTE MONITORING REGULATORS, INSTALL 3/4" STEEL CONTROL LINE 10 PIPE DIAMETERS OF CUSTOMER'S HOUSE LINE (10 PIPE DIAMETER STARTS AFTER THE REDUCER - ITEM 18).
- B. GALVANIZED PIPE AND FITTINGS ARE THE PREFERRED MATERIALS OF CHOICE. BLACK PIPE, PRIMED AND PAINTED IS ALSO ACCEPTABLE.
- C. WHERE VEHICLE TRAFFIC IS A CONCERN, PROTECTION POST ARE REQUIRED. REFER TO APPROVED KEYSpan PROTECTION POST STANDARDS.
- D. DO NOT WELD METER IN PLACE. USE A SPOOL PIECE.
- E. ALL WELDING MUST CONFORM TO API-1104 PROCEDURES. ALL PIPING SHALL BE TESTED AT 1.5 MAOP OF INLET SERVICE PRESSURE FOR 30 MINUTES.
- F. PREFABRICATED METER SETS COME WITH 2" X 6-3/4" LONG SPOOL PIECE IN PLACE OF METER.
- G. 2" STRAINERS (ITEM ID 9340158) AND FILTERS (ITEM ID 9341258) CAN BE USED TO PROTECT EQUIPMENT FROM IN LINE DEBRIS. FOR PREFABRICATED SETS USE A FLANGED ELBOW (ITEM ID 9383780) AND ROTATE FLANGED TEE AFTER INLET VALVE FOR STRAINER/FILTER INSTALLATION. SEE FIGURE 2 ON PAGE 9.
- H. FOR PREFABRICATED SETS THAT REQUIRE DUAL RATES, INSTALL FLANGED TEE ON THE RISER VALVE AND THEN ROTATE FLANGED TEE ON THE PREFABRICATED SET FOR THE SECOND METER HEADER. SEE FIG 1 ON PAGE 9.
- I. ELEVATED PRESSURE SHALL BE ONLY USED IF CUSTOMER'S EQUIPMENT REQUIRES IT. IT WILL NOT BE APPROVED TO DOWNSIZE HOUSE LINE.

ITEM	DESCRIPTION	ITEM I.D	QTY	MATERIAL NOTES
1	VALVE – 2" PLUG NORDSTROM FIG 143	9341980	6	FLANGED ENDS
2	FLANGE 2" WELD NECK FLAT FACE	9341058	12	PER ASTM A-105 GR. B OR A-350 LF-2
3	ELBOW 2" WELD END 90 DEG. LONG RADIUS	9341213	3	STD. WALL PER A-234 WPB
4	BOLTS MACHINE – 5/8" X 2-3/4" W/2H HEX NUT	9339766	56	
5	PIPE SUPPORTS SADDLE – (TOP SECTION ONLY)	9339861	2	INCLUDED IN PREFABRICATED SET
	PIPE SUPPORT BASE 20"-25" HEIGHT (BOTTOM SECT)	9323172	2	SEE MTRS-6475 FOR PIPE SUPPORTS
	PIPE SUPPORT BASE 26"-31" HEIGHT (BOTTOM SECT)	9339886	2	CHOOSE THE BASE WHICH WILL DETERMINE
	PIPE SUPPORT BASE 32"-41" HEIGHT (BOTTOM SECT)	9339885	2	THE OVERALL LENGTH OF THE SUPPORT (FROM GROUND TO BOTTOM OF PIPE)
6	PIPE 2" STD. WALL (SCH. 40)	9340729	15'	PER A-106 GR. B
7	GASKET 2" FULL FACE FOR 150# FF FLANGE	9341161	13	KLINGER NITRILE TYPE C-4401
8	TEE 2", WELD END STD. WALL PER A-234 WPB	9342462	3	ALT. IN 1 LOCATION, USE FLANGED TEE 371139
9	METER 8C, 1.5M OR 3M TEMPERATURE CORRECTED	+	1	
10	COUPLING 2" LOCK TYPE	9341621	1	
11	THRED-O-LET 3/4"X 2"PIPE	9341652	4	PER A-105 GRADE B
12	PLUG 3/4" SOLID STEEL	9340912	6	4 BY KEYSpan/2 BY CUSTOMER
13	NIPPLE 3/4" X 3" LONG, GALVANIZED	9340631	4	2 BY KEYSpan/2 BY CUSTOMER
14	VALVE 3/4" LOCKWING, GALVANIZED TAMPER PROOF	9339593	4	2 BY KED/2 BY CUST. – AY McDONALD 525B
15	THREADED 2" NIPPLE X 2" FLAT FACE 150# FLANGE	9383856	2	ALT USE ITEM 2 AND 6 AND THREAD ONE END
16	2" FISHER S302 OR B34SR (1,100 CFH MAX) OR 2" FISHER S203 RELIEF MONITOR REGULATOR OR 2" B34IMRV RELIEF / MONITOR REGULATOR 2" FISHER CS-806IR 1/2" ORIF. (100 PSIG MAX WITH 1/2" ORIF, FOR 124 PSIG INLET 3/8" ORIF. REQ'D) 2" FISHER CS-803IR 5/8" ORIF. 60. PSIG MAX 2" FISHER CS-806IR 7/8" ORIF. 50 PSIG MAX.  SPRING FOR FISHER S203 - 14" SET POINT (8.5" – 18" GRAY) ITEM ID 9342699 SPRING FOR FISHER S203 - 1 PSIG (28") SET POINT (14" – 30" DARK GREEN) ITEM ID 9342194 SPRING FOR ITRON B34IMRV – 14" AND 28" SET POINT 11.5" – 28" SP. RANGE – BLUE) ITEM ID 9342636 SPRING FOR FISHER CS-806 14" – 30" GREEN 9386657 SPRING FOR FISHER CS-806 1 PSIG – 2.25 PSIG BLUE 9386658 SPRING FOR FISHER CS-806 2.5 PSIG – 5.5 PSIG YELLOW 9386658	9342660 9383314 9342684 9386776  9386778 9386779	2	
17	NIPPLE 2" X 4" LONG GALVANIZED STD. WT	BY CUST.	2	
18	REDUCER 2" X CUST. HOUSE LINE SIZE GLAV.	BY CUST.	2	
19	PIPE – CUST. HOUSE LINE SIZE. GALVANIZED	BY CUST	A/R	
20	COUPLING CUSTOMER HOUSE LINE SIZE LOCK TYPE	BY CUST	2	
21	TEE CUST. HOUSE LINE SIZE X 3/4", THREADED, GALV.	BY CUST.	2	
22	INSULATING FLANGE KIT	9340992	2	
23	METER PAD 7' LONG X 4' WIDE X 6" THICK	BY CUST.	1	

**BILL OF MATERIAL**



7M HIGH PRESSURE  
 ROTARY METER, VERTICAL POSITION  
 WITH DUAL REGULATORS



**INSTALLATION NOTES**

- A. FOR 99 AND 124 PSIG SERVICES, THE ITRON B-34 IMRV REGULATOR OR THE FISHER S-203 AND S-302 REGULATOR MUST HAVE THE ORIFICE CHANGED TO 3/8". THE ITRON B34IMRV AND FISHER S-302 AND S-203 REGULATOR HAVE INTERNAL MONITORS WHICH SERVE AS OVER PRESSURE PROTECTION. ALL OTHER REGULATORS (SUCH AS FISHER S-201 AND 133 SERIES) MUST USE SEPARATE RELIEF VALVES FOR OVER PROTECTION. FISHER 133 AND S-203P REQUIRE DOWNSTREAM CONTROLS. FOR THESE AND OTHER REMOTE MONITORING REGULATORS, INSTALL 3/4" STEEL CONTROL LINE 10 PIPE DIAMETERS OF CUSTOMER'S HOUSE LINE (10 PIPE DIAMETER STARTS AFTER THE REDUCER - ITEM 18).
- B. GALVANIZED PIPE AND FITTINGS ARE THE PREFERRED MATERIALS OF CHOICE. BLACK PIPE, PRIMED AND PAINTED IS ALSO ACCEPTABLE.
- C. WHERE VEHICLE TRAFFIC IS A CONCERN, PROTECTION POST ARE REQUIRED. REFER TO APPROVED KEYSpan PROTECTION POST STANDARDS.
- D. DO NOT WELD METER IN PLACE. USE A SPOOL PIECE.
- E. ALL WELDING MUST CONFORM TO API-1104 PROCEDURES. ALL PIPING SHALL BE TESTED AT 1.5 MAOP OF INLET SERVICE PRESSURE FOR 30 MINUTES.
- F. PREFABRICATED METER SETS COME WITH 2" X 6-3/4" LONG SPOOL PIECE IN PLACE OF METER.
- G. 2" STRAINERS (ITEM ID 9340158) AND FILTERS (ITEM ID 9341258) CAN BE USED TO PROTECT EQUIPMENT FROM IN LINE DEBRIS. FOR PREFABRICATED SETS USE A FLANGED ELBOW (ITEM ID 9383780) AND ROTATE FLANGED TEE AFTER INLET VALVE FOR STRAINER/FILTER INSTALLATION. SEE FIGURE 2 ON PAGE 9.
- H. FOR PREFABRICATED SETS THAT REQUIRE DUAL RATES, INSTALL FLANGED TEE ON THE RISER VALVE AND THEN ROTATE FLANGED TEE ON THE PREFABRICATED SET FOR THE SECOND METER HEADER. SEE FIG 1 ON PAGE 9.
- I. ELEVATED PRESSURE SHALL BE ONLY USED IF CUSTOMER'S EQUIPMENT REQUIRES IT. IT WILL NOT BE APPROVED TO DOWNSIZE HOUSE LINE.

ITEM	DESCRIPTION	ITEM I.D	QTY	MATERIAL NOTES
1	VALVE – 2" PLUG NODSTROM FIG 143	9341980	6	FLANGED ENDS
2	FLANGE 2" WELD NECK FLAT FACE	9341058	12	PER ASTM A-105 GR. B OR A-350 LF-2
3	ELBOW 2" WELD END 90 DEG. LONG RADIUS	9341213	3	STD. WALL PER A-234 WPB
4	BOLTS MACHINE – 5/8" X 2-3/4" W/2H HEX NUT	9339766	56	
5	PIPE SUPPORTS SADDLE – (TOP SECTION ONLY)	9339861	2	INCLUDED IN THE PREFABRICATED SET
	PIPE SUPPORT BASE 20"-25" HEIGHT (BOTTOM SECT)	9323172	2	SEE MTRS-6475 FOR PIPE SUPPORTS
	PIPE SUPPORT BASE 26"-31" HEIGHT (BOTTOM SECT)	9339886	2	CHOOSE THE BASE WHICH WILL DETERMINE
	PIPE SUPPORT BASE 32"-41" HEIGHT (BOTTOM SECT)	9339885	2	THE OVERALL LENGTH OF THE SUPPORT (FROM GROUND TO BOTTOM OF PIPE)
6	PIPE 2" STD. WALL (SCH. 40)	9340729	15'	PER A-106 GR. B
7	GASKET 2" FULL FACE FOR 150# FF FLANGE	9341161	11	KLINGER NITRILE TYPE C-4401
8	TEE 2", WELD END STD. WALL PER A-234 WPB	9342462	3	ALT. IN 1 LOCATION, USE FLANGED TEE 371139
9	METER 7M TEMPERATURE CORRECTED	+	1	
10	COUPLING 2" LOCK TYPE	9341621	1	
11	THRED-O-LET 3/4"X 2"PIPE	9341652	4	PER A-105 GRADE B
12	PLUG 3/4" SOLID STEEL	9340912	4	3 BY KEYSpan/1 BY CUSTOMER
13	NIPPLE 3/4" X 3" LONG, GALVANIZED	9340631	4	2 BY KEYSpan/1 BY CUSTOMER
14	VALVE 3/4" LOCKWING, GALVANIZED TAMPER PROOF	9339593	4	2 BY KED/1 BY CUST. – AY McDONALD 525B
15	THREADED 2" NIPPLE X 2" FLAT FACE 150# FLANGE	9383856	2	ALT USE ITEM 2 AND 6 AND THREAD ONE END
16	2" FISHER S302 OR B34SR (1,100 CFH MAX) OR 2" FISHER S203 RELIEF MONITOR REGULATOR OR 2" B34IMRV RELIEF / MONITOR REGULATOR 2" FISHER CS-806IR 1/2" ORIF. (100 PSIG MAX WITH 1/2" ORIF, FOR 124 PSIG INLET 3/8" ORIF. REQ'D) 2" FISHER CS-803IR 5/8" ORIF. 60. PSIG MAX 2" FISHER CS-806IR 7/8" ORIF. 50 PSIG MAX.  SPRING FOR FISHER S203 - 14" SET POINT (8.5" – 18" GRAY) ITEM ID 9342699 SPRING FOR FISHER S203 - 1 PSIG (28") SET POINT (14" – 30" DARK GREEN) ITEM ID 9342194 SPRING FOR ITRON B34IMRV – 14" AND 28" SET POINT 11.5" – 28" SP. RANGE – BLUE) ITEM ID 9342636 SPRING FOR FISHER CS-806 14" – 30" GREEN 9386657 SPRING FOR FISHER CS-806 1 PSIG – 2.25 PSIG BLUE 9386658 SPRING FOR FISHER CS-806 2.5 PSIG – 5.5 PSIG YELLOW 9386658	9342660 9383314 9342684 9386776  9386778 9386779	2	SEE NOTE A
17	NIPPLE 2" X 4" LONG GALVANIZED STD. WT	BY CUST.	2	
18	REDUCER 2" X CUST. HOUSE LINE SIZE GLAV.	BY CUST.	2	
19	PIPE – CUST. HOUSE LINE SIZE. GALVANIZED	BY CUST.	2	
20	COUPLING CUSTOMER HOUSE LINE SIZE LOCK TYPE	BY CUST.	2	
21	TEE CUST. HOUSE LINE SIZE X 3/4", THREADED, GALV.	BY CUST.	2	
22	INSULATING FLANGE KIT	9340992	1	
23	METER PAD 7' LONG X 4' WIDE X 6" THICK	BY CUST.	1	
24	REDUCER 3" X 2" CONCENTRIC, WELD END	9342651	2	
25	FLANGE 3" WELD END FLAT FACE	9341388	2	PER ASTM A-105 GR. B
26	GASKET 3" FULL FACE	9341162	2	

**BILL OF MATERIAL**

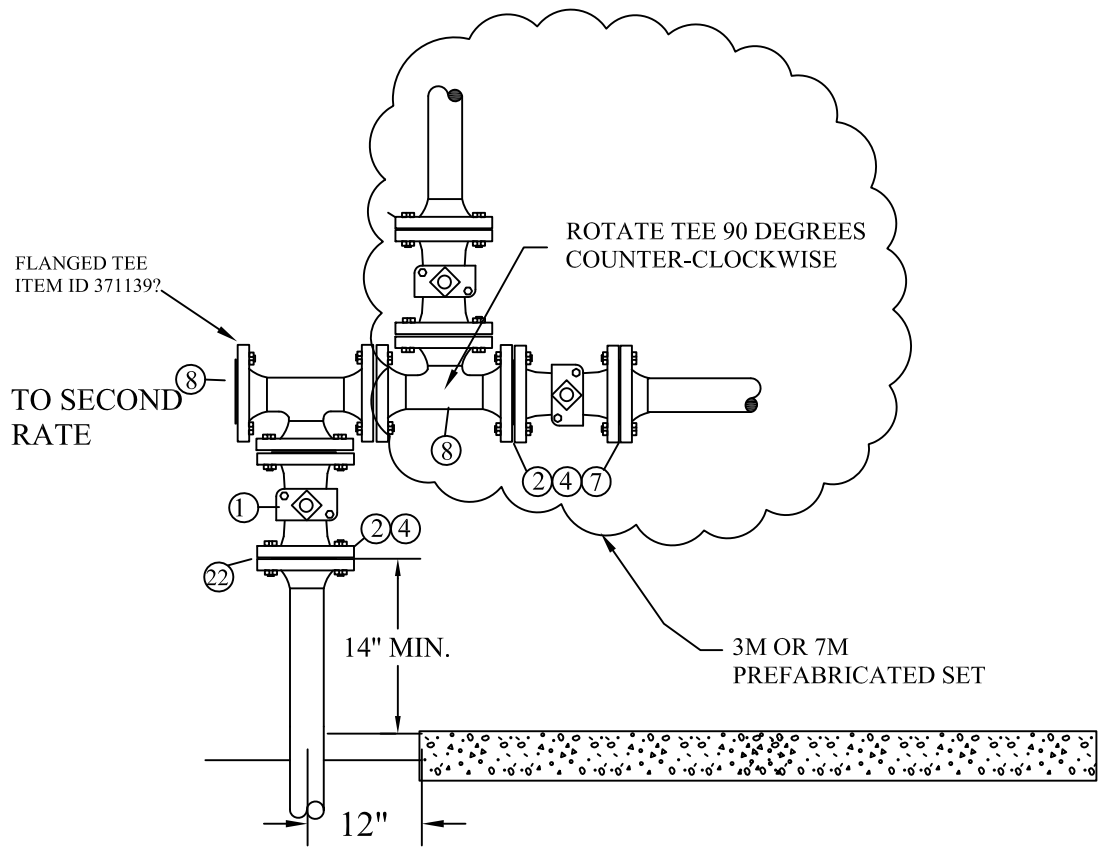


FIGURE 1 - FOR DUAL RATES

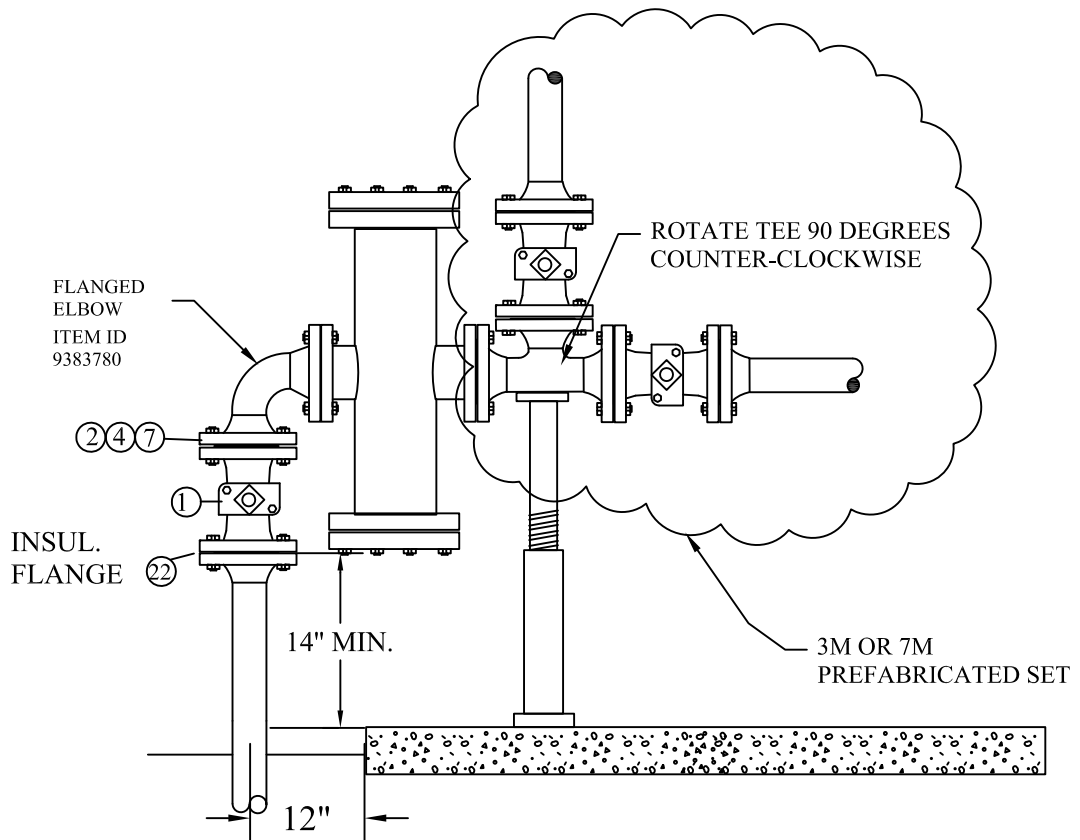
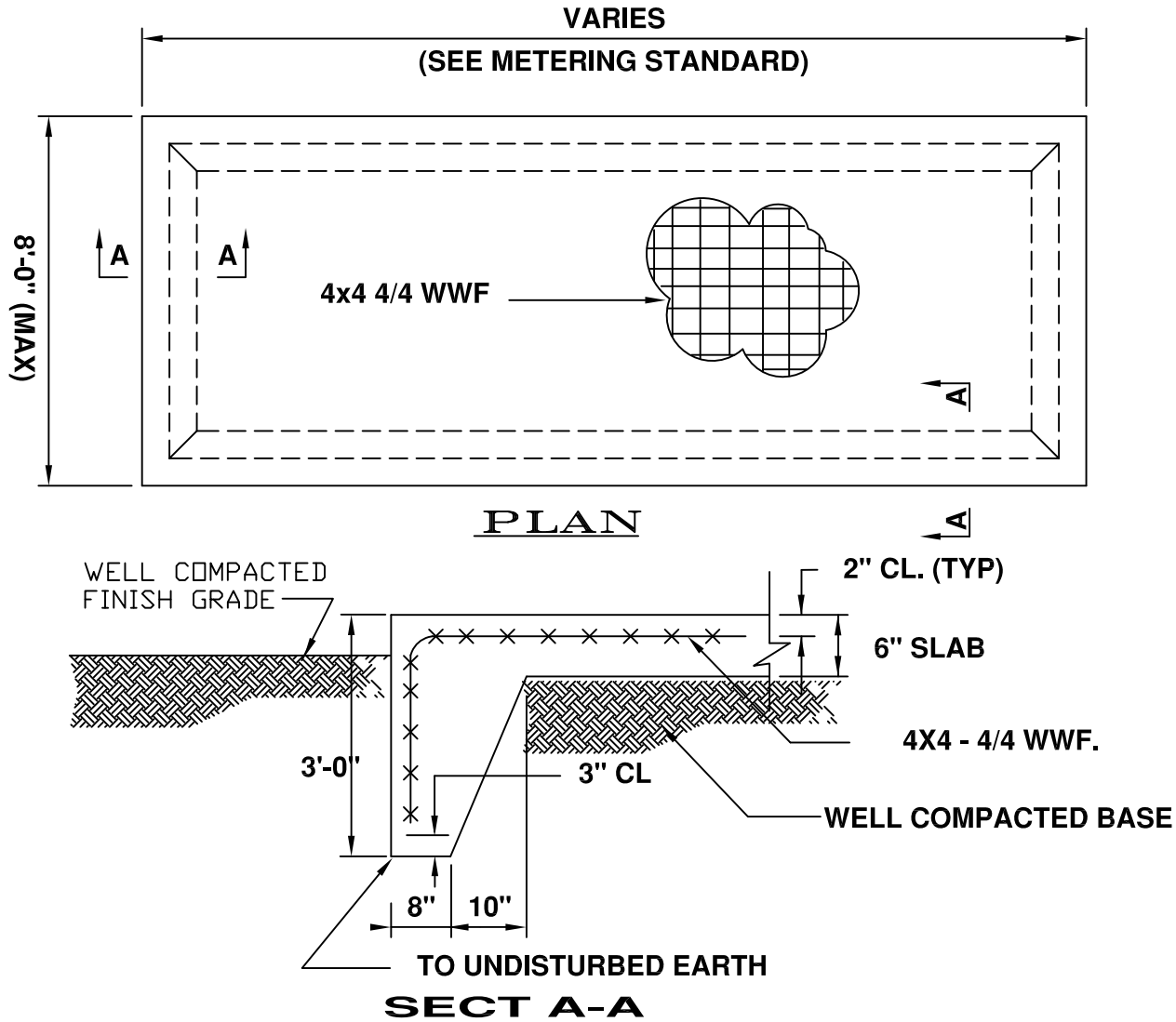


FIGURE 2 - FOR  
FILTER/STRAINER  
INSTALLATIONS

**PREFERRED FOOTING CONSTRUCTION FOR SUPPORTING GAS METER HEADERS  
WHOSE CONFIGURATIONS CONTAIN MORE THAN ONE PIPE SUPPORT**



**NOTES**

1. THIS CONSTRUCTION STANDARD SHALL BE USED FOR SUPPORTING GAS METER SETS
2. ALL CONCRETE IS TO DEVELOP TO A MINIMUM COMPRESSIVE STRENGTH OF  $F_c=3000$  psi AT THE TIME OF USE.
3. REINFORCING STEEL SHALL CONFORM TO APPLICABLE ASTM STANDARDS UP TO GRADE 60.
4. CONCRETE DESIGN AND CONSTRUCTION SHALL CONFORM TO ACI STANDARD "BUILDING CODE REQUIREMENTS" FOR REINFORCED CONCRETE (ACI).
5. FOUNDATION (FOOTING) SIZE AND LOCATION WILL BE AGREED UPON BY NATIONAL GRID PRIOR TO WORK ORDER APPROVAL.
6. CONCRETE FOUNDATION OR FOOTING SHALL BE INSTALLED BY THE CUSTOMER BEFORE THE SERVICE IS INSTALLED BY NATIONAL GRID

**nationalgrid**

LI, MA, NH, NYC

**CONCRETE FOUNDATION AND/OR  
FOOTINGS FOR ROTARY GAS METER  
OUTSIDE LOCATIONS**

**REVISIONS:** MADE APPLICABLE FOR ALL REGIONS

DATE: 07/01/2003

EFFECTIVE DATE: 05/15/2007

DESIGN: GJK

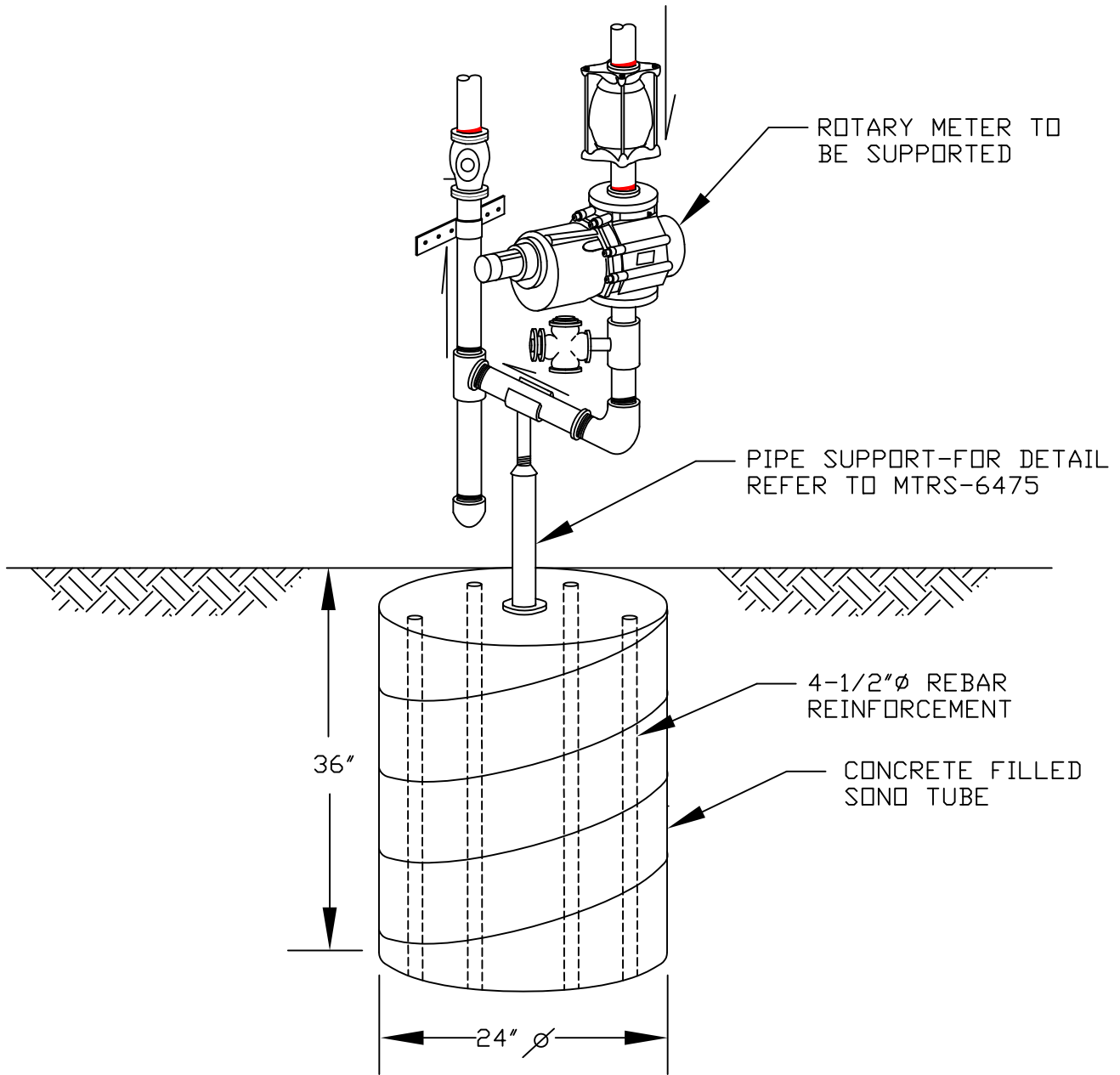
STD. DWG.

DRAWN: HF

NO. **MTRS-6505**

ALTERNATE CONSTRUCTION METHOD

CONCRETE FILLED SAND-TUBE FOOTING MAY BE USED TO SUPPORT GAS METER HEADER CONFIGURATIONS REQUIRING ONE (1) PIPE SUPPORT



NOTE: THIS APPLICATION REQUIRES 10 BAGS OF CONCRETE MIX.  
(1 BAG = 1 CU. FT. = 60 LB.)

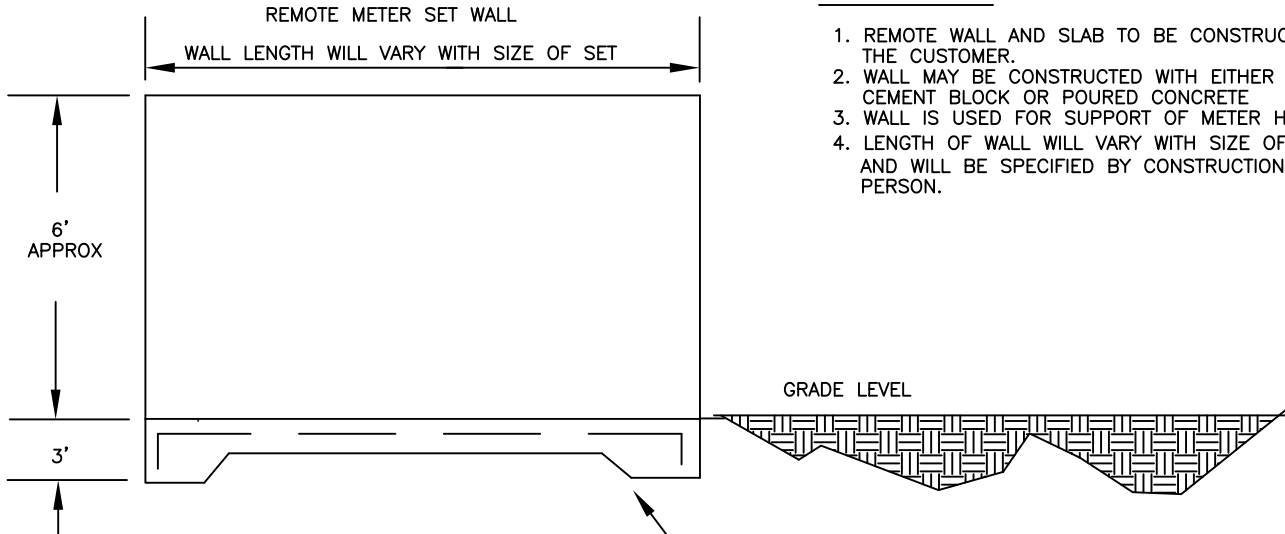
# REMOTE WALL FOR SUPPORT OF ROTARY AND MULTI METER HEADERS

## FRONT VIEW

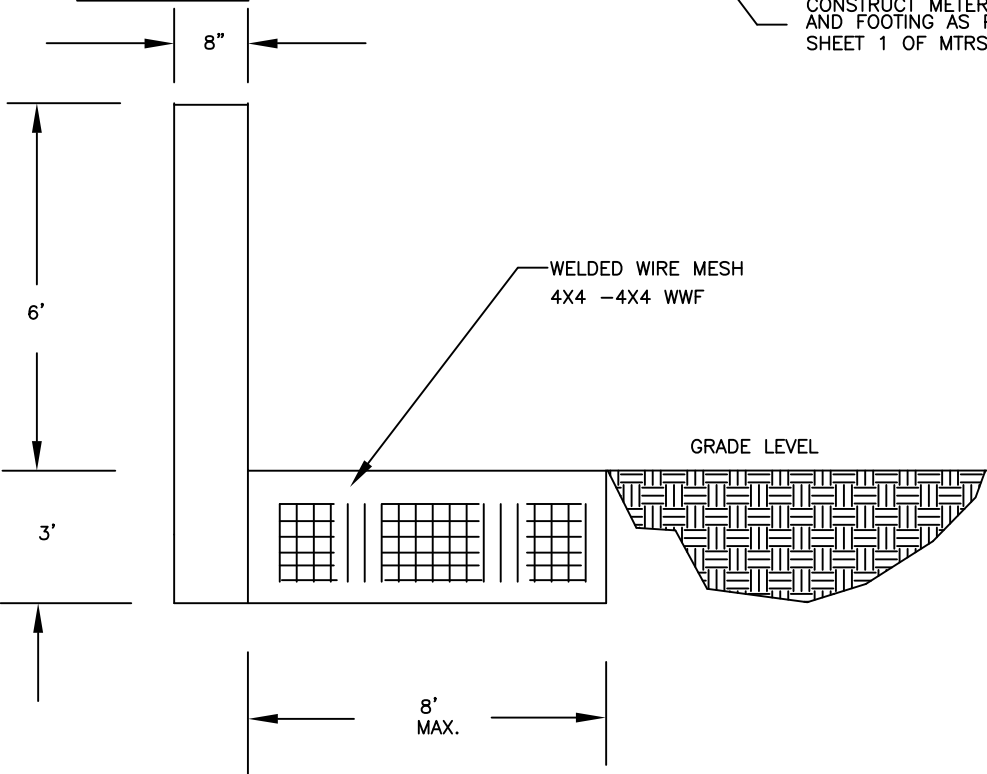
KED DOES NOT ACCEPT LIABILITY FOR THE CONSTRUCTION OF THE WALL BUILT BY THE CUSTOMER.

## NOTES:

1. REMOTE WALL AND SLAB TO BE CONSTRUCTED BY THE CUSTOMER.
2. WALL MAY BE CONSTRUCTED WITH EITHER CEMENT BLOCK OR POURED CONCRETE
3. WALL IS USED FOR SUPPORT OF METER HEADER.
4. LENGTH OF WALL WILL VARY WITH SIZE OF HEADER, AND WILL BE SPECIFIED BY CONSTRUCTION LEAD PERSON.




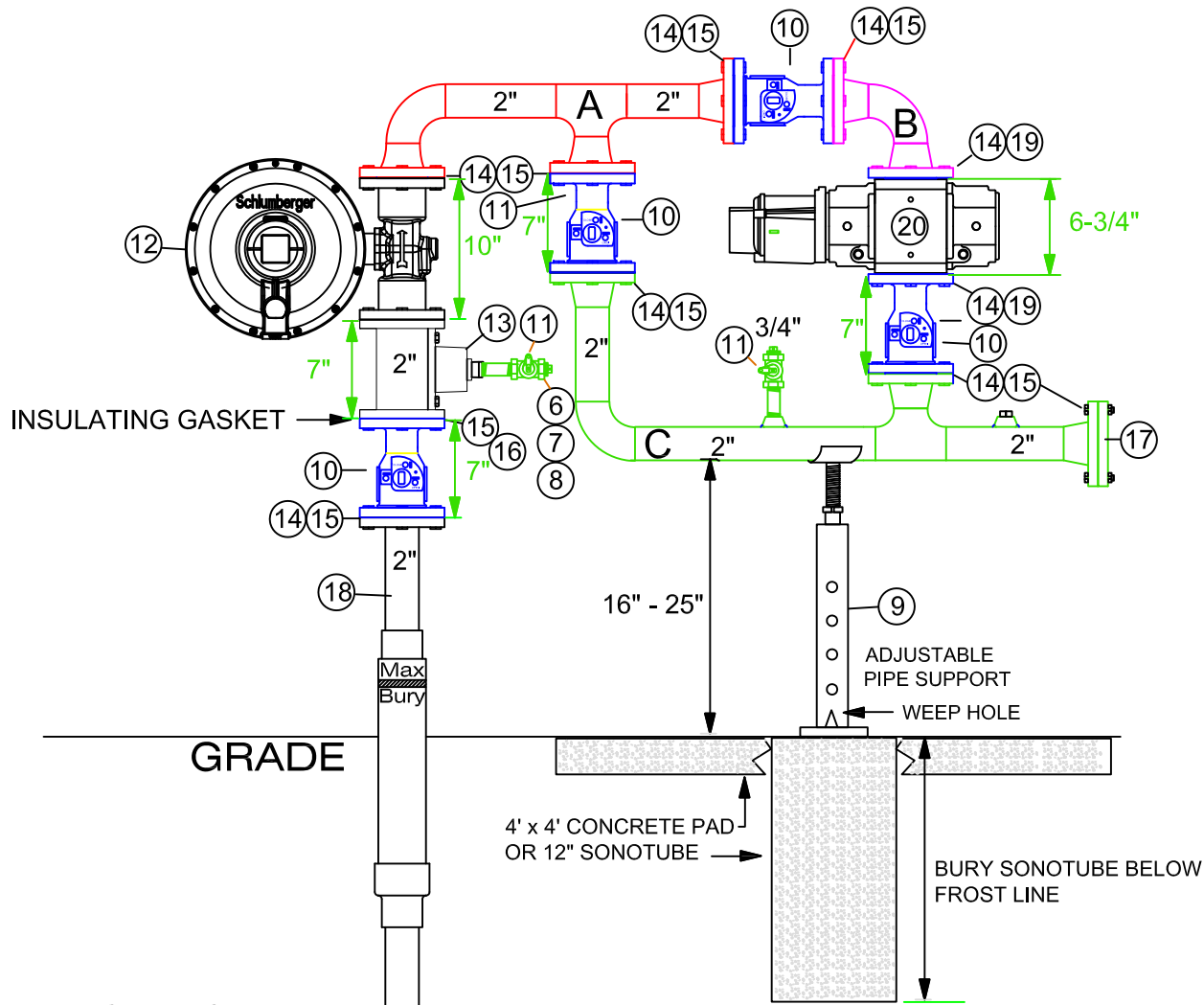
## SIDE VIEW



## GENERAL NOTES

- A. THESE GENERAL NOTES APPLY TO ALL ROTARY GAS METER CONSTRUCTION STANDARDS.
- B. FOR TYPICAL L.P BOOSTER LAYOUT BY THE CUSTOMER, SEE MTRS-6535-LI.
- C. FLOW DIRECTION OF FILTER, REGULATOR AND METER SHALL BE IN ACCORDANCE WITH ARROW INDICATOR ON BODY PARTS.
- D. BYPASS VALVE SHALL BE CLOSED AND LOCKED BY NATIONAL GRID.
- E. RISER PIPE SHALL BE COVERED OR IN CONTACT WITH CONCRETE.
- F. PIPING TO SCHOOL BLDG. MUST COMPLY WITH THE CODE REQUIREMENT OF THE " NEW YORK STATE MANUAL OF PLANNING STANDARDS FOR SCHOOL BUILDINGS". WHICH STATES THAT WELDED CONSTRUCTION IS REQUIRED FOR PIPE SIZES 3" IN DIAMETER AND OVER. SECTION 709-F-1.
- G. CONTRACTOR SHALL INSTALL VENT PIPING WHEN SPECIFIED. THE SIZE AND LOCATION TO BE DETERMINED BY NATIONAL GRID GRID. SEE 020013-CS.
- H. UNLESS OTHERWISE SPECIFIED, ALL PIPING MUST BE IN COMPLIANCE WITH NFPA-54 AND NATIONAL GRID SPECIFICATIONS AND REQUIREMENTS FOR GAS INSTALLATIONS. WELDED CONSTRUCTION IS REQUIRED AS PER NFPA SEC. 2.6.8 d1.
- I. A SINGLE REGULATOR AND ASSOCIATED PIPING INSTALLATION IS MOST ACCEPTABLE, AND, PARALLEL REGULATORS ARE INSTALLED ONLY WHEN CONTINUITY OF SUPPLY TO THE CUSTOMER IS A PRIORITY. NATIONAL GRID MUST AGREE ON FINAL DESIGN.
- J. WHERE SOIL IS OR WILL BE DISTURBED, A CONCRETE SLAB (FOUNDATION) FOR FOOTING SHALL BE USED AND PROVIDED BY THE CUSTOMER. SIZE AND LOCATION WILL BE AGREED UPON BY NATIONAL GRID. (USE THE MINIMUM ACCEPTABLE SIZE) SEE MTRS-6505-LI.
- K. ALL UNCOATED WELDED PIPING ON METER HEADERS SHALL BE PRIMED WITH A RUST INHIBITING PRIMER, AND PAINTED WITH AN OIL BASED, ALKYD RUSTOLEUM PRODUCT, OR EQUAL. FOR METER SETS WHICH USE GALVANIZED SCREWED PIPING, PAINTING IS NOT REQUIRED. ALL UNPAINTED METER HEADERS 2" AND ABOVE INSTALLED BY NATIONAL GRID SHALL BE COATED PER 030030-TI.
- L. THE GAS SERVICE LOCATION TAG SHALL BE INSTALLED PER SERV-6305-LI
- M. ALL FITTING AND MATERIALS, LOCATED DOWNSTREAM OF THE METER SHALL BE DESIGNED AND RATED FOR NATURAL GAS. THIS INCLUDES BUT IS NOT LIMITED TO VALVES, COUPLINGS AND APPLIANCES.
- N. A METER BYPASS SHOULD BE INSTALLED IN ACCORDANCE WITH THE METERING STANDARD DRAWING AND WHERE IT WOULD BE DIFFICULT OR COSTLY TO INTERRUPT SERVICE TO THE CUSTOMER.
- O. AFTER PURGING THE SERVICE, AND BEFORE INSTALLING THE METER, THE LOCKWING METER VALVE ON THE RISER PIPE, AND ON THE BYPASS, SHALL BE LOCKED BY NATIONAL GRID
- P. SERVICE RISER, METER HEADER AND METER SHALL BE LOCATED TO PREVENT DAMAGE CAUSED BY VEHICLES AND MECHANICAL EQUIPMENT. PROTECTION SHALL BE INSTALLED IN ACCORDANCE WITH MTRS-6060-LI.
- Q. THE METER SHALL BE PLUMB AND LEVEL
- R. ALL EXPOSED THREADED PIPING AND FITTINGS SHALL BE GALVANIZED.
- S. ALL PIPING, FITTING, ETC. SHALL BE THOROUGHLY CLEANED OF ALL FOREIGN MATTER BEFORE BEING INSTALLED.
- T. PIPE STRAPS OR HANGERS ARE TO BE USED FOR SUPPORT. THE PLACEMENT OF THE SUPPORT DEPENDS ON THE CONFIGURATION OF THE METER SET AND CUSTOMER'S HOUSE LINE.
- U. THE METER VALVES SHOULD FACE FORWARD FROM THE WALL FOR EASY ACCESSIBILITY.
- V. NO CLOSE (FULLY THREADED) NIPPLES SHALL BE INSTALLED ON METER SETS.
- W. REGULATOR AND METER CAN BE ROTATED TO FIT FIELD CONDITIONS. IF NECESSARY, SWING REGULATOR OR METER TO OBTAIN CLEARANCE.
- X. THESE STANDARDS REFLECT THREADED PIPING FOR SYSTEMS THAT OPERATE AT ½ PSIG OR LESS AND HAVE 4" DIAMETER OR SMALLER PIPING. FOR HIGHER PRESSURE AND OR LARGER DIAMETER PIPE, THE STANDARD REFLECTS USE OF WELDED CONSTRUCTION. THIS IS IN ACCORDANCE WITH THE NATIONAL FUEL GAS CODE..
- Y. THE INSULATED FLANGE KIT SHALL BE INSTALLED AT THE SAME TIME THAT THE SERVICE LINE VALVE IS INSTALLED.
- Z. NATIONAL GRID WILL SUPPLY ONLY THE NUMBER OF PIPE SUPPORTS LISTED ON THE BILL OF MATERIAL IN THE APPLICABLE METERING STANDARD. FOR INSTALLATION BY THE CUSTOMER OR HIS CONTRACTOR DETAILS OF THE PIPE SUPPORT ARE PROVIDED IN MTRS-6475-LI

 LONG ISLAND	<b>GENERAL NOTES FOR ROTARY GAS METERS</b>	
	REVISIONS:	DATE: 07/01/2003 DESIGN: ML DRAWN: ML



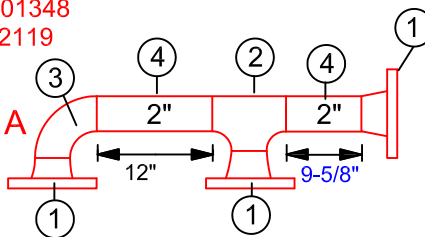
**TO BE USED FOR:  
800 SCFH TO 3,000 SCFH  
7", 14" OR 1 PSIG OUTLET**

**\* ALL DIMENSIONS ARE  
BASED ON WELD NECK  
FLANGES, 3/32" WELD GAP  
AND 1/16" THICK GASKETS**

**PREFAB COMPONENTS**

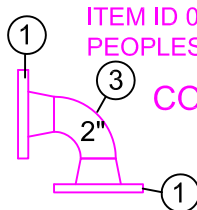
ORACLE ITEM ID 00301348  
PEOPLESOFT ID 9202119

**COMPONENT A**



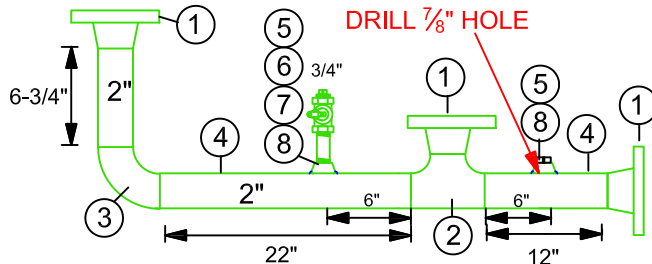
ITEM ID 00320205 NYC, LI  
PEOPLESOFT ID 9202120

**COMPONENT B**

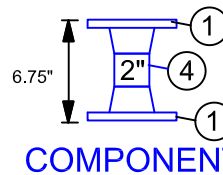


ORACLE ID 00301349  
PEOPLESOFT ID 9202121

**COMPONENT C**



METER SPOOL PIECE  
ORACLE ID 00301600



**COMPONENT D**

**nationalgrid**

LI-MA-NH-NYC-RI-UNY

**8C - 3M PREFAB METER  
HEADER**

**REVISIONS:** REVISED DIMENSION IN COMPONENT "A"

DATE: 03/26/2010

EFFECTIVE DATE: 01/15/2011

DESIGN: B. FOSTER/P. GUGLIOTTA

STD. DWG.

DRAWN: B. FOSTER/P. GUGLIOTTA

NO. **020010-CS**

**FIELD INSTALLATION NOTES**

- A. CONTACT ENGINEERING FOR REGULATOR SIZING.
- B. WHERE VEHICLE TRAFFIC IS A CONCERN, PROTECTION POST ARE REQUIRED. NATIONAL GRID PROTECTION POST STANDARDS MTRS-6060 CAN BE USED AS A GUIDELINE.
- C. DO NOT WELD METER IN PLACE. USE A SPOOL PIECE.
- D. ALL PREFAB PIPING SHALL SURFACE PREPARATION, PRIMING AND PAINTING SPECIFICATION: ALL SURFACES SHALL BE SOLVENT CLEANED IN ACCORDANCE WITH SSPC SP#1 STANDARD TO REMOVE ALL SOLUBLE SURFACE CONTAMINATES. APPLICATION SHALL BE ONE COAT OF SOLVENT BASED GRAY PRIMER MINIMUM OF 2-3 MILS, FOLLOWED BY ONE COAT OF SOLVENT-BASED ASA #49 GRAY ACRYLIC ENAMEL MINIMUM OF 2-3 MILS, OR EQUIVALENT AS APPROVED BY NATIONAL GRID ENGINEERING.

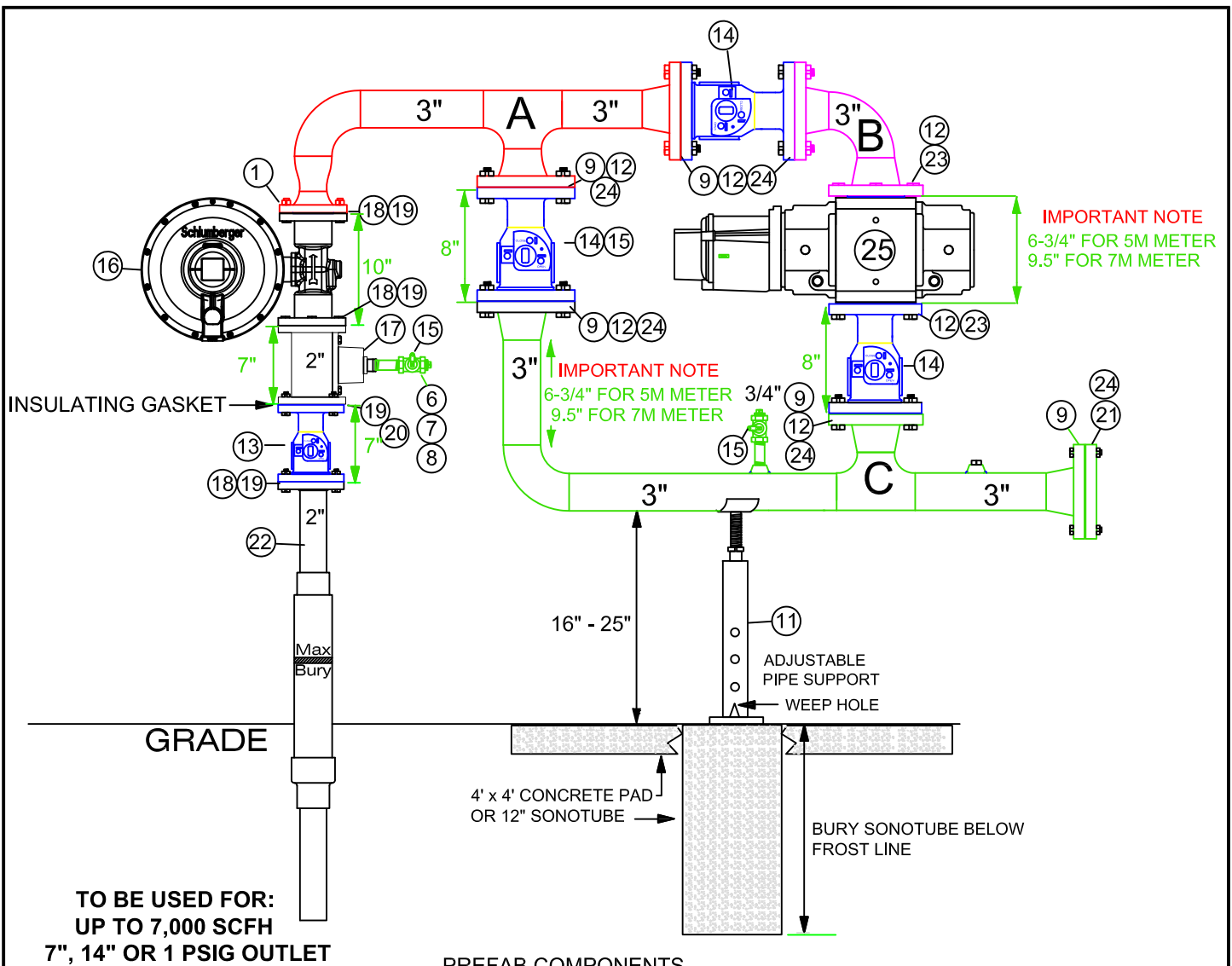
**PREFABRICATION NOTES FOR ITEMS 1- 9**

- E. ALL WELDING MUST CONFORM TO API-1104 PROCEDURES.
- F. RADIOGRAPH SHALL BE 10% OF ALL WELDS OR PER NATIONAL GRID'S WELDING POLICY PROCEDURE.
- G. ALL FLANGE OPENINGS SHALL BE COVERED WITH PLASTIC CAPS.
- H. ASSEMBLY SHALL BE SUPPLIED IN 4 PIECES (3 PIPING & 1 FOR SUPPORT).
- I. FITTINGS SHALL CONFORM TO ASTM A-234 WPB STD. WALL AND ASTM A-105.
- J. PIPING SHALL CONFORM TO NATIONAL GRID SPEC. 120020-MS.
- K. ALL PIPING SHALL BE PRESSURE TESTED TO 90 PSIG FOR 5 MINUTES OR PER NATIONAL GRID'S PRESSURE TESTING PROCEDURE.

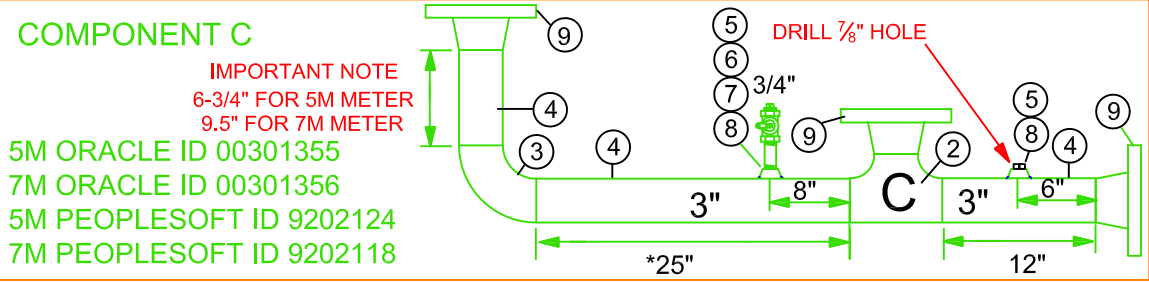
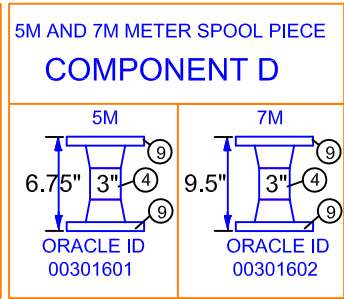
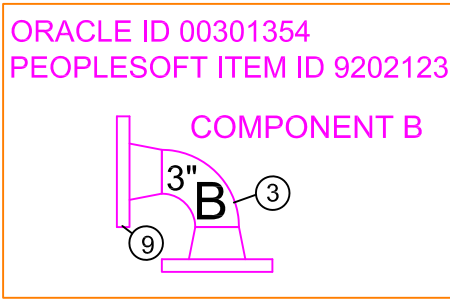
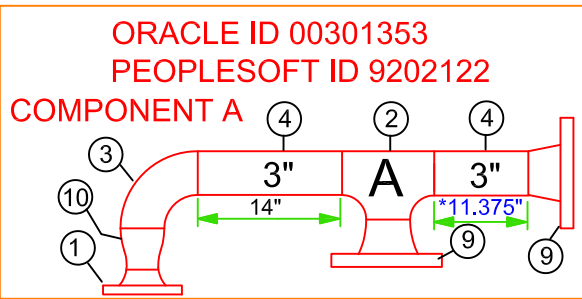
**BILL OF MATERIAL**

ITEM	DESCRIPTION	ORACLE ITEM I.D	PEOPLE SOFT ID	QTY	MATERIAL NOTES
<b>PREFABRICATED ITEMS 1 – 8 LISTED BELOW</b>					
1	FLANGE 2" WELD NECK FLAT FACE	00322156	0810533	10	PER ASTM A-105 GR. B OR A-350 LF-2
2	TEE 2", WELD END STD. WALL PER A-234 WPB	00371196	6012154	2	
3	ELBOW 2" WELD END 90 DEG. LONG RADIUS	00320232	6005621	3	4801246 IN R.I. STD WALL, PER A-234 WPB
4	PIPE 2" STEEL, STD. WALL (SCH. 40)	00350059	6001110	6'	PER A-106 GR. B OR API 5L GR. B
5	THRED-O-LET 3/4"X 2"PIPE 3000#	00372000	6013436	2	PER A-105 GRADE B
6	NIPPLE 3/4" X 3" LONG	00343134	6007103	2	
7	VALVE 3/4" LOCKWING, TAMPER PROOF	00315006	6008330	2	
8	PLUG 3/4" SOLID STEEL OR CI	00352005	6009604	3	
<b>OR PREFABRICATED COMPLETED COMPONENTS:</b>					
A	2 INCH FLANGED REGULATOR OUTLET PIECE	00301348	9202119	1	
B	FLANGED ELBOW	00320205	9202120	1	
C	FLANGED METER OUTLET PIECE	00301349	9202121	1	
D	SPOOL PIECE 8C, 1.5M OR 3M METER 2" X 6.75"	00301600	NA	1	
<b>REMAINING ITEMS 9 – 20</b>					
9	PIPE SUPPORT 16"-25" HEIGHT (BOTTOM SECTION) ADJUSTIBLE FROM 16" – 25"	00308041 00308049	0810350 Incl. above	1 1	FOR ADDITIONAL SUPPORTS SEE MTRS-6475
10	VALVE – 2" BALL VALVE CLASS 150# FLANGED ENDS	00382033	9202103	4	
11	LOCKING DEVICE	00136506	3020150 UNY	3	4800520 FOR RI
12	REGULATOR 2" ACTARIS B34IMRV FLANGED ENDS 3/8" ORIFICE GREEN/WHITE SPRING 5.5" – 7.2" W.C. SET AT 7" W.C. (100 PSIG MAX INLET) OR ACTARIS B38 IMR AMERICAN 1843 WITH OPSO FISHER S-203 FISHER S-208/209 WITH VSX SLAM SHUT	AS REQ'D	9202214	1	REGULATORS MUST BE SIZED FOR THE FULL CAPACITY AT MINIMAL OPERATING PRESSURES AND MUST BE RATED FOR THE MAX OPERATING PRESSURE. CONTACT ENGINEERING.
13	STRAINER 2" FLANGED	00301028	9202107	1	
14	GASKET 2" FULL FACE FOR 150# FF FLANGE	00138057	6003869	11	FLEXITALLIC SIGMA 511 PINK
15	BOLTS MACHINE – 5/8" X 2-1/4" W/2H HEX NUT	00110044	6013701 UNY	48	4800368 & 4800373 FOR RI
16	INSULATING FLANGE KIT / GASKET 150#	00333017	6003533 UNY	1	4801273 IN RI
17	FLANGE, BLIND 2", CLASS 150# FF	00322019	4801287	1	
18	RISER 2"	Field	Field	1	
19	BOLTS FOR METER 5/8" X 1.5" LONG	00362028	Meter Ops.	8	
20	METER 8C, 1.5M OR 3M TEMPERATURE CORRECTED	Meter Ops.	Meter Ops.	1	





PREFAB COMPONENTS



\* ALL DIMENSIONS ARE BASED ON WELD NECK FLANGES, 3/32" WELD GAP AND 1/16" THICK GASKETS

<p>LI-MA-NH-NYC-RI-UNY</p>	<h2 style="margin: 0;">5M AND 7M PREFAB METER HEADER</h2>
----------------------------	---

<b>REVISIONS:</b> REVISED DIMENSIONS IN COMPONENT "A"	DATE: 03/26/2010	EFFECTIVE DATE: 01/15/2011
	DESIGN: B. FOSTER/P. GUGLIOTTA	STD. DWG. NO.
	DRAWN: B. FOSTER/P. GUGLIOTTA	020011-CS

**INSTALLATION NOTES**

- A. CONTACT ENGINEERING FOR PROPER REGULATOR SIZING
- B. WHERE VEHICLE TRAFFIC IS A CONCERN, PROTECTION POST ARE REQUIRED. NATIONAL GRID PROTECTION POST STANDARDS MTRS-6060 CAN BE USED AS A GUIDELINE.
- C. DO NOT WELD METER IN PLACE. USE A SPOOL PIECE.
- D. ALL PREFAB PIPING SHALL SURFACE PREPARATION, PRIMING AND PAINTING SPECIFICATION: ALL SURFACES SHALL BE SOLVENT CLEANED IN ACCORDANCE WITH SSPC SP#1 STANDARD TO REMOVE ALL SOLUBLE SURFACE CONTAMINATES. APPLICATION SHALL BE ONE COAT OF SOLVENT BASED GRAY PRIMER MINIMUM OF 2-3 MILS, FOLLOWED BY ONE COAT OF SOLVENT-BASED ASA #49 GRAY ACRYLIC ENAMEL MINIMUM OF 2-3 MILS, OR EQUIVALENT AS APPROVED BY NATIONAL GRID ENGINEERING.

**PREFABRICATION NOTES FOR ITEMS 1- 11**

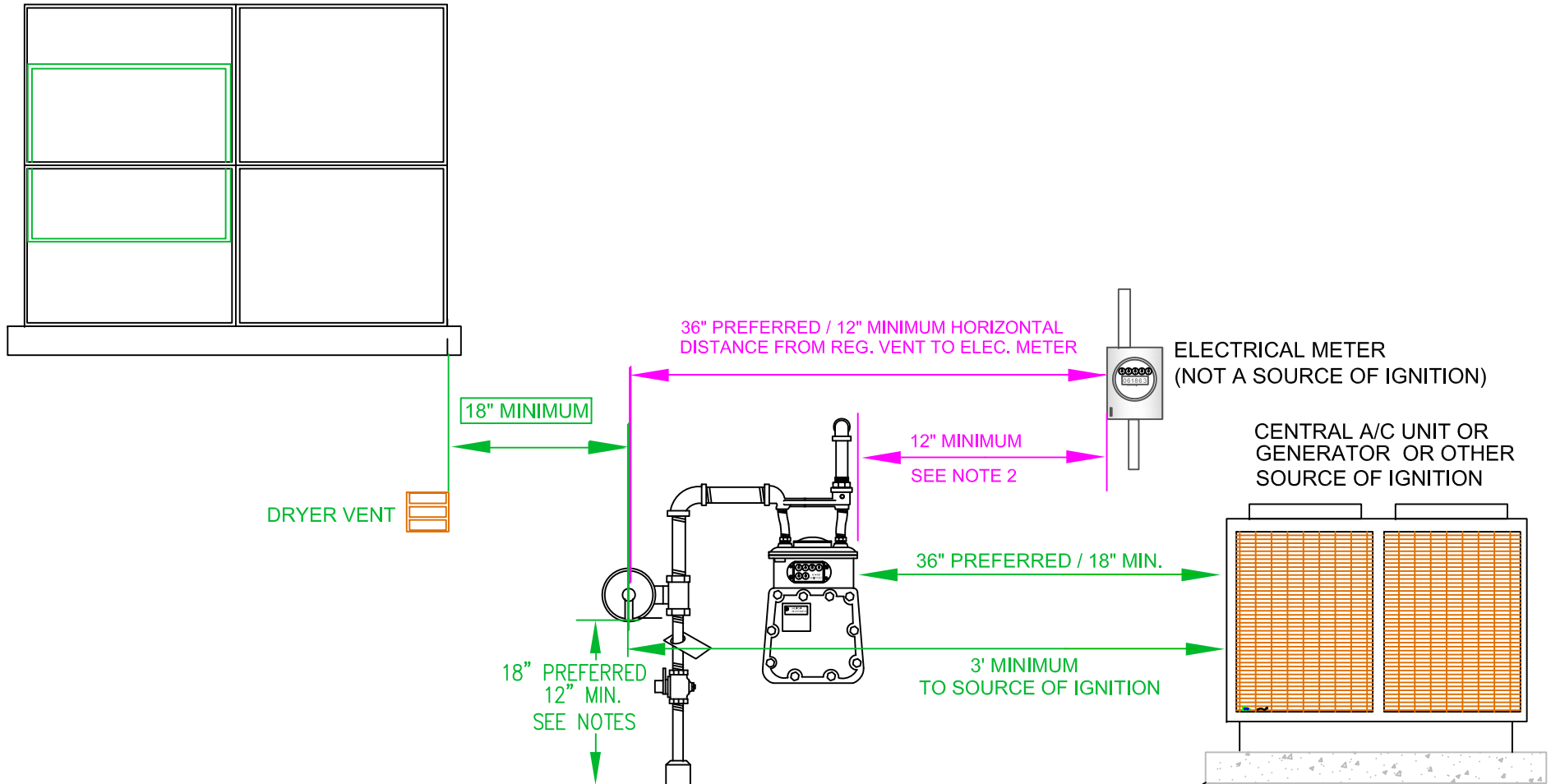
- E. ALL WELDING MUST CONFORM TO API-1104 PROCEDURES.
- F. ALL PIPING SHALL BE TESTED AT 90 PSIG MINIMUM FOR 5 MINUTES
- G. 10% OF THE WELDS SHALL BE RADIOGRAPHED PER API-1104 OR PER NATIONAL GRID'S WELDING POLICY PROCEDURES.
- H. ALL OPEN END FLANGE OPENINGS SHALL BE COVERED WITH PLASTIC CAPS.
- I. ASSEMBLY SHALL BE SUPPLIED IN 4 PIECES (3 PIPING & 1 FOR SUPPORT).
- J. FITTINGS SHALL CONFORM TO ASTM A-234 WPB STD. WALL AND ASTM A-105.
- K. PIPING SHALL CONFORM TO NATIONAL GRID SPECIFICATION 120020-MS.


**BILL OF MATERIAL**

ITEM	DESCRIPTION	ORACLE ITEM ID LI, NYC, NE	PEOPLE SOFT ITEM ID UNY, RI	QTY	MATERIAL NOTES
<b>PREFABRICATED ITEMS 1 – 10 LISTED BELOW</b>					
1	FLANGE 2" WELD NECK FLAT FACE CLASS 150#	00322156	0810533	1	PER ASTM A-105 GR. B OR A-350 LF-2
2	TEE 3", WELD END STD. WALL PER A-234 WPB	00371200	4801571	2	
3	ELBOW 3" WELD END 90 DEG. LONG RADIUS	00320245	6005720	3	STANDARD WALL, PER A-234 WPB
4	PIPE 3" STEEL, STD. WALL (SCH. 40)	00350109	4800573	5'	PER A-106 GR. B
5	THRED-O-LET ¾" X 3" PIPE 3000#	00372000	6013436	3	PER A-105 GRADE B
6	NIPPLE ¾" X 3" LONG	00343134	6007103	2	
7	VALVE ¾" LOCKWING, TAMPER PROOF	00315006	6008330	2	
8	PLUG ¾" SOLID STEEL OR C.I.	00352005	6009604	3	
9	FLANGE 3" WELD NECK FLAT FACE CLASS 150#	00322036	0810950	9	PER ASTM A-105 GR. B OR A-350 LF-2
10	REDUCER 3" X 2" CONC., STD. WALL, WELD END <b>OR PREFABRICATED COMPLETED COMPONENTS</b>	00356082	6013133	1	PER ASTM A234-WPB
A	2" X 3" FLANGED REGULATOR OUTLET	00301353	9202122	1	
B	3" FLANGED ELBOW	00301354	9202123	1	
C 5M	5M FLANGED METER OUTLET <b>OR</b>	00301355	9202124	1	
C 7M	7M FLANGED METER OUTLET	00301356	9202118	1	
D 5M	5M FLANGED SPOOL PIECE	00301601	NA	1	
D 7M	7M FLANGED SPOOL PIECE	00301602	NA	1	
<b>REMAINING ITEMS 11 - 25</b>					
11	PIPE SUPPORT 16"-25" HEIGHT (BOTTOM SECT) ADJUSTABLE FROM 16" – 25" (TOP SECTION)	00308041 00308049	0810350 Incl. above	1	FOR ADDITIONAL SUPPORTS SEE MTRS-6475
12	GASKET 3" CLASS 150# FULL FACE	00317021	6003547	8	FLEXITALLIC SIGMA 511 PINK OR APPROVED EQ.
13	VALVE – 2" BALL VALVE CLASS 150# FLANGED ENDS	00382033	9202103	1	
14	VALVE - 3" BALL VALVE CLASS 150# FLANGED ENDS	00382036	9202104	3	
15	LOCKING DEVICE	00136506	3020150 UNY	3	4800520 IN RI
16	REGULATOR 2" FLANGED ENDS ACTARIS B34IMRV 3/8" ORIF. 100 PSIG MAX 7" SET OR ACTARIS B38 IMR AMERICAN 1843 WITH OPSO FISHER S-203 FISHER S-208/209 WITH VSX SLAM SHUT	AS REQ'DS REQ'D By Eng	9202214 By Eng.	1	REGULATORS MUST BE SIZED FOR THE FULL CAPACITY AT MINIMAL OPERATING MAIN PRESSURES AND MUST BE RATED FOR MAXIMUM OPERATING PRESSURES. CONTACT ENGINEERING.
17	STRAINER 2" FLANGED	00301028	9202107	1	
18	GASKET 2" FULL FACE FOR 150# FF FLANGE	00138057	6003869	3	
19	BOLTS MACHINE – 5/8" X 2-1/4" FHN HEX NUT	00110044	6013701 UNY	16	4800368 FOR BOLT / 4800373 FOR NUT IN RI
20	INSULATING FLANGE KIT / GASKET 150#	00333017	6003533 UNY	1	4801273 IN RI
21	FLANGE BLIND 3"	00322020	4801264	1	
22	RISER 2"	By Field	By Field	1	
23	BOLTS FOR METER 5/8" X 1.5" LONG	00362028	Meter Ops	8	
24	MACHINE BOLTS, 5/8" X 2.75" LONG WITH HEX NUT	00309303	6013701 UNY	32	4800362 FOR BOLT /4800373 FOR NUTIN RI
25	METER 5M OR 7M TEMPERATURE CORRECTED	Meter Ops	Meter Ops	1	

**BILL OF MATERIAL**

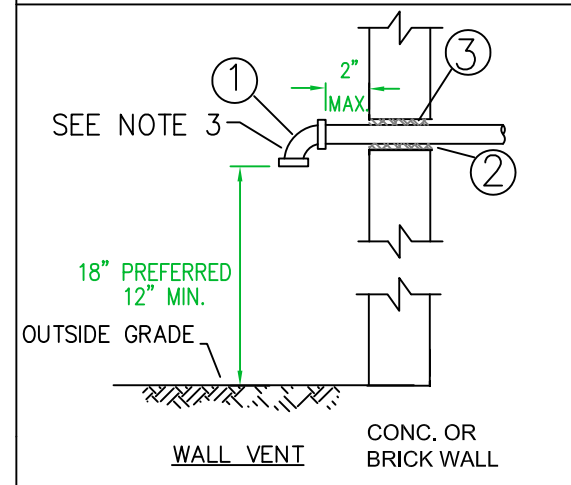
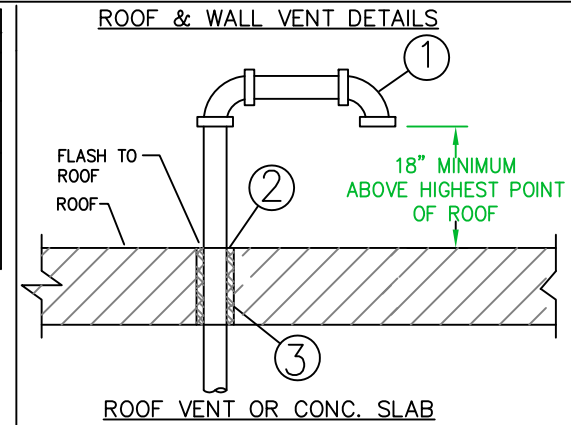
PREFERRED INSTALLATIONS:



 ALL REGIONS	OUTDOOR LOCATION FOR REGULATOR AND RELIEF VALVE VENT TERMINUS	
	DATE: 07/15/2010 DESIGN: PAUL GUGLIOTTA DRAWN: PAUL GUGLIOTTA	EFFECTIVE DATE: 12/15/2015 STD. DWG. NO. 020013-CS
Key Changes: REVISED CLEARANCES TO ELECTRIC METER AND WINDOWS		

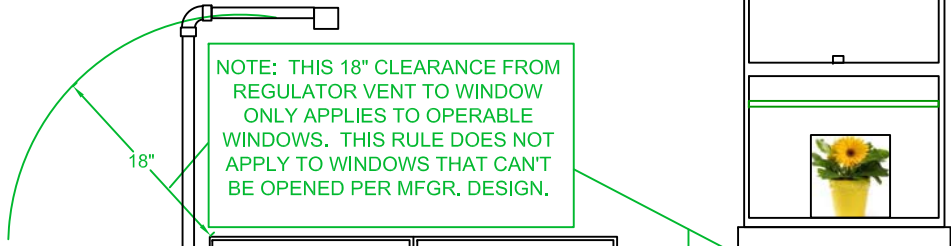
**GUIDELINES FOR NON-PREFERRED INSTALLATIONS:**

#	ITEM	SIZE	ITEM ID	
			LI/NYC/MA	UNY / RI
3	PIPE SLEEVE		---	---
2	SEALING COMPOUND		9330862	NON STOCK
1	VENT ASSEMBLY, WITH RAIN & INSECT RESISTANT SCREEN	3/4"	9358637	NON STOCK
		1"	9358640	9315859
		1-1/4"	9358638	NON STOCK
		1-1/2"	9358641	NON STOCK
		2"	9358636	9310355



**SERVICE REGULATOR VENT RESTRICTIONS**

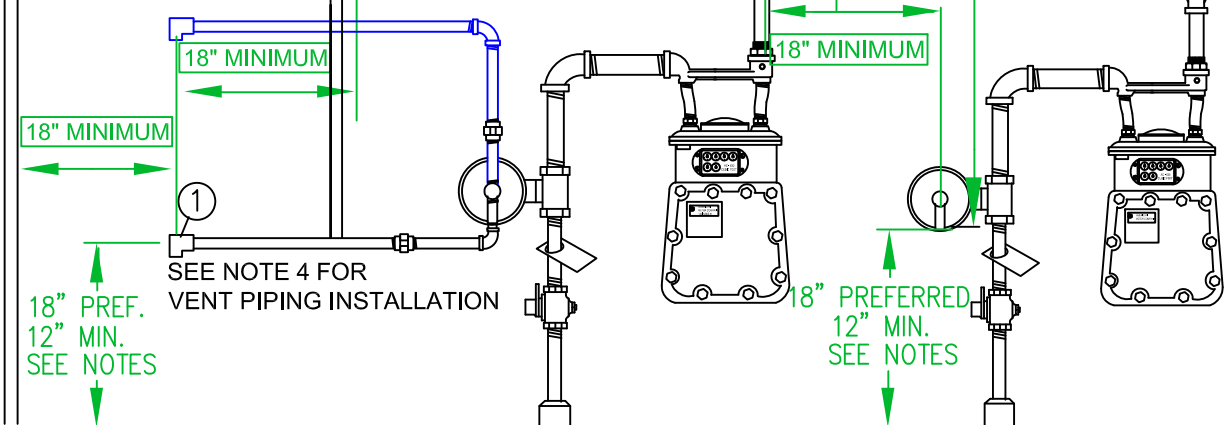
NOTE: THIS 18" CLEARANCE FROM REGULATOR VENT TO WINDOW ONLY APPLIES TO OPERABLE WINDOWS. THIS RULE DOES NOT APPLY TO WINDOWS THAT CAN'T BE OPENED PER MFGR. DESIGN.



6' MINIMUM VERTICAL CLEARANCE FROM WINDOW

METER SETS LOCATED UNDER THE WINDOW SHOULD BE AVOIDED

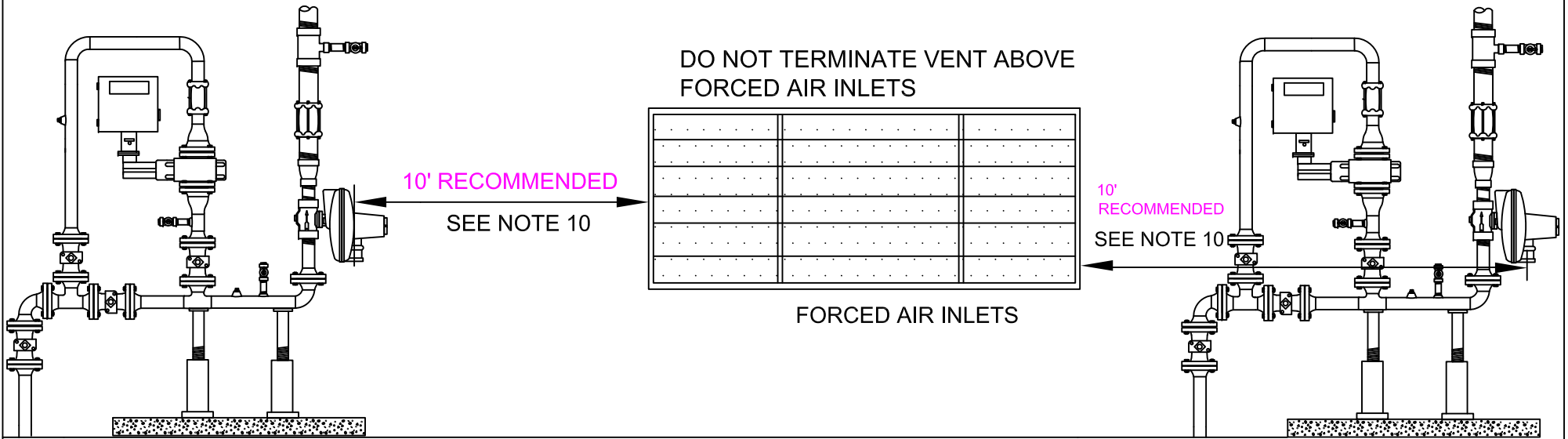
SEE NOTE 7 FOR VENTING PIPING FACING UP



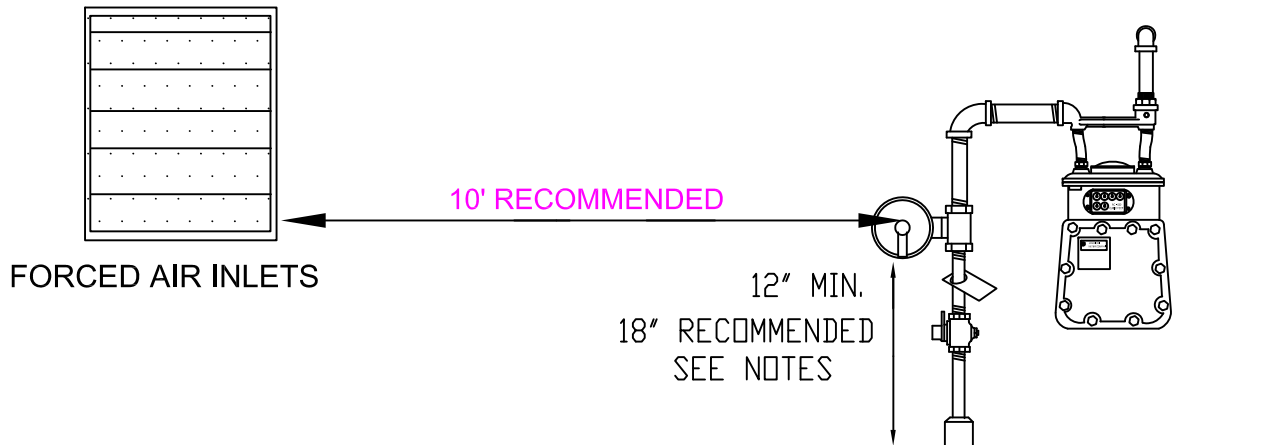
18" PEF.  
12" MIN.  
SEE NOTES

18" PREFERRED  
12" MIN.  
SEE NOTES

LARGE COMMERCIAL & INDUSTRIAL INSTALLATIONS



DO NOT TERMINATE VENT ABOVE FORCED AIR INLETS



**NOTES:**

1. A REGULATOR VENT CANNOT BE LOCATED UNDER AN OVERHANG THAT CAN TRAP GAS SUCH AS A PITCHED AWNING WITH SIDES. A VENT MAY BE LOCATED UNDER A FLAT SURFACE HORIZONTAL OVERHANG UNDER 6' IN LENGTH AS LONG AS THE OVERHANG HAS NO OPENINGS INTO THE BUILDING WITHIN 18 INCHES OF THE VENT TERMINUS.
  2. **A GAS METER** MUST HAVE A MINIMUM OF 12" HORIZONTAL CLEARANCE DISTANCE FROM A STANDARD ELECTRIC METER.
  3. **THE GAS REGULATOR** VENT TERMINUS MUST:
    - HAVE A MINIMUM CLEARANCE OF 36" PREFERRED / 12" MINIMUM HORIZONTAL DISTANCE FROM A STANDARD ELECTRIC METER. IF THE REGULATOR IS WITHIN 36" OF THE ELECTRIC METER, THE VENT SHOULD BE PIPED AWAY FROM THE ELECTRIC METER.
- NOTE: VENTLESS AND VENT LIMITING REGULATORS DO NOT APPLY TO THE FOLLOWING GUIDELINES AND THERE IS NO MINIMUM DISTANCES ESTABLISHED FOR VENT LIMITING AND VENTLESS REGULATORS TO SOURCES OR IGNITION AND BUILDING OPENINGS.**
4. THE OUTSIDE TERMINAL OF EACH SERVICE REGULATOR VENT MUST:
    - HAVE A RAIN AND INSECT RESISTANT SCREEN
    - BE LOCATED AT A PLACE WHERE ANY VENTING GAS CAN ESCAPE FREELY INTO ATMOSPHERE
    - BE AWAY FROM ANY WINDOWS, DOORS, SOFFIT VENTS OR ANY OPENINGS WHERE GAS CAN ENTER THE BUILDING. MAINTAIN A MINIMUM OF 18 INCHES HORIZONTAL CLEARANCE IF THAT OPENING IS WITHIN 6 FEET VERTICALLY OF THE VENT TERMINUS. **WINDOWS THAT ARE DESIGNED BY MANUFACTURER *NOT TO OPEN* ARE EXEMPT FROM THE 18 INCH RULE**
    - BE PROTECTED FROM DAMAGE WHERE ICE ACCUMULATION MAY OCCUR
    - IT IS PREFERRED THAT REGULATOR VENTS BE INSTALLED AT A HEIGHT 18 INCHES ABOVE GRADE, HOWEVER, THE MINIMUM ALLOWABLE VENT HEIGHT SHALL BE 12 INCHES ABOVE FINAL GRADE. IN CASES OF KNOWN FLOOD LOCATIONS, THE PREFERRED REGULATOR VENT HEIGHT ABOVE THE FLOOD HEIGHT IS 18" (12" MINIMUM).
  5. THE METER ASSEMBLY SHALL BE LOCATED TO PREVENT DAMAGE BY VEHICLES AND MECHANICAL EQUIPMENT. WHERE THIS IS NOT PRACTICAL, ADDITIONAL PROTECTION SHALL BE INSTALLED. SEE MTRS-6060.
  6. GALVANIZED PIPE AND FITTINGS FOR VENT PIPING IS PREFERRED (REQUIRED ON L.I.) PROPERLY COATED BLACK IRON PIPE IS PERMITTED.
  7. IF A VENT NEEDS TO BE EXTENDED, STRAIGHT PIPING IS PREFERRED, BUT IF NOT PRACTICAL, A VENT LINE "TRAP" IS ACCEPTABLE.
    - ON OUTSIDE METER SETS, AN INSULATED UNION (LI) OR INSULATED COUPLING (NY) IS PREFERRED ON ALL VENT LINES UNDER 3' AND REQUIRED ON ALL VENT LINES > 3'.
    - ON **ALL** INSIDE SETS, AN INSULATING UNION OR INSULATED COUPLING IS REQUIRED ON THE VENT PIPING. THIS INSULATED UNION OR INSULATED COUPLING SHALL BE LOCATED AS CLOSE TO THE REGULATOR AS POSSIBLE.
  8. IT IS PREFERRED THAT THE METER AND RISER NOT BE LOCATED UNDER A WINDOW.
  9. VENT LINES SHOULD BE INSTALLED ABOVE GRADE. BELOW GRADE VENT LINES SHOULD BE AVOIDED. HOWEVER, WHERE IT IS NOT POSSIBLE, VENT LINES INSTALLED UNDERGROUND SHALL BE PROTECTED FROM CORRODING. THIS INCLUDES WRAPPING THE ENTIRE LINE WITH APPROVED COATING 030031-CS, INSTALLING A 3 LB BAG ANODE (ITEM ID 9339401) (OR LARGER) AND INSTALLING AN INSULATING FITTING BETWEEN THE REGULATOR AND THE BELOW GRADE SECTION (TYPICALLY INSIDE THE BUILDING). **ANY NEW VENT LINE THAT PASSES THROUGH A CONCRETE OR MASONRY WALL OR FOUNDATION, SHALL BE SLEEVED AND THE ANNULAR SPACE SHALL BE SEALED TO PREVENT WATER INTRUSION.** FOR SITUATIONS THAT ARE NOT COVERED BY THE PROVISIONS OF THIS STANDARD, CONTACT GAS ENGINEERING.
  10. ON LARGE RESIDENTIAL, COMMERCIAL & INDUSTRIAL SETS WHERE LARGE FORCED AIR INTAKE SYSTEMS ARE PRESENT, ENGINEERING APPROVAL IS REQUIRED FOR REGULATOR/RELIEF VALVE TERMINATION POINTS.
  11. ON EXISTING INSTALLATIONS WHERE UNDERGROUND VENT LINE IS FOUND, THE VENT LINE SHOULD BE RELOCATED ABOVE GROUND. IF THIS IS NOT POSSIBLE, IT MUST BE PRESSURE TESTED AT 3 PSIG AND INSPECTED FOR CORROSION. IF IT PASSES THE PRESSURE TEST AND THE PIPE IS VISUALLY ACCEPTABLE, IT THEN SHALL BE CATHOLICALLY PROTECTED PER 030031-CS AND BROUGHT IN TO COMPLIANCE AS DESCRIBED IN NOTE 9.

**CLEARANCE GUIDELINES:**

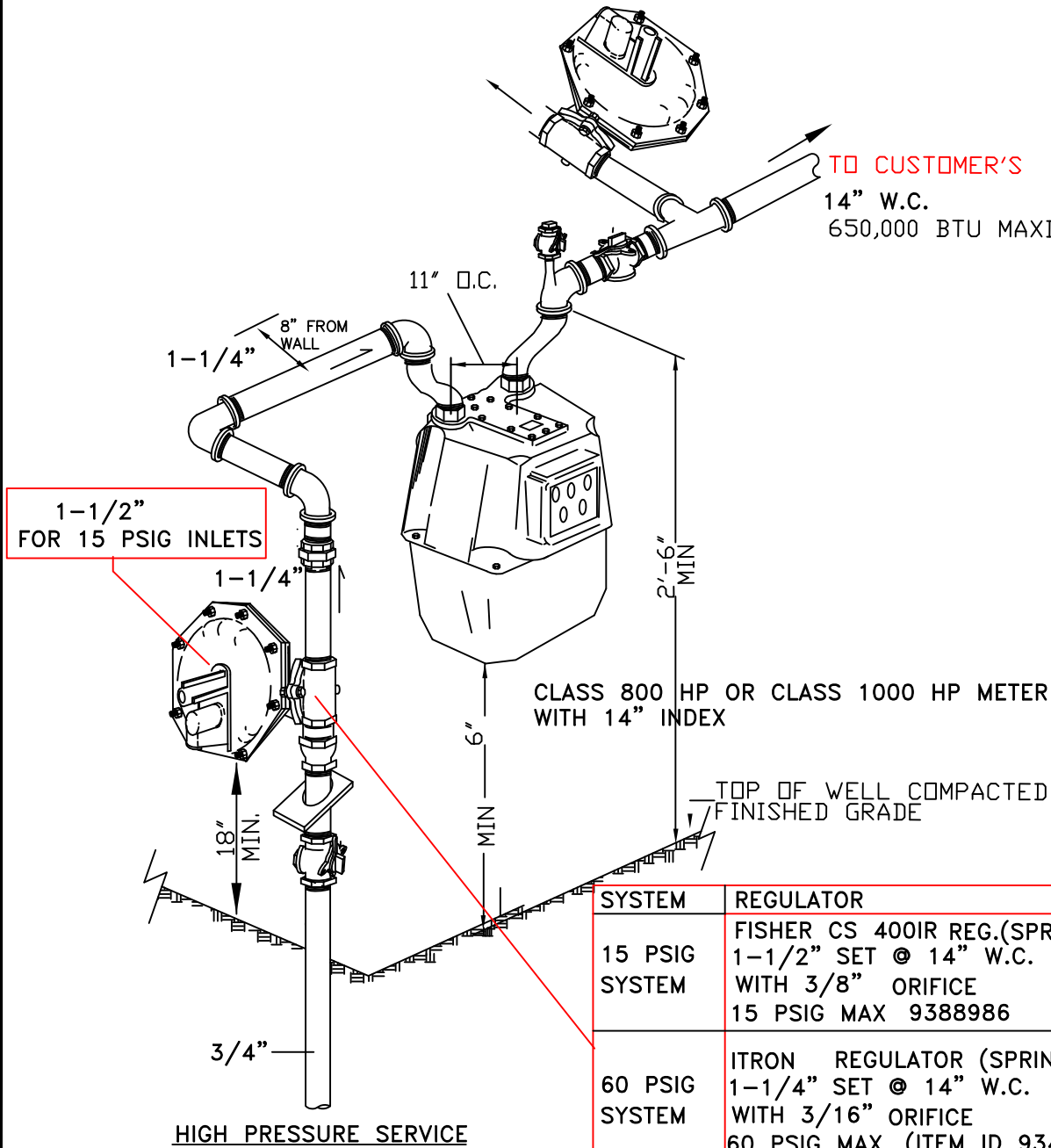
SITUATION	MINIMUM DISTANCE
STANDARD ELECTRIC METER	12 INCHES HORIZONTAL DISTANCE FROM GAS METER TO ELECTRIC METER 36 INCHES PREFERRED / 12 INCHES MIN. DISTANCE FROM REGULATOR VENT TERMINUS TO ELECTRIC METER
IGNITION SOURCE	36 INCHES RECOMMENDED / 18 INCHES MINIMUM FROM GAS METER AND <b>36 INCHES MINIMUM DISTANCE FROM REGULATOR VENT TERMINUS TO SOURCE OF IGNITION</b>
WINDOW, DOOR, SOFFIT VENT, OTHER OPENINGS INTO BUILDING	18 INCHES HORIZONTAL AND 6 FEET VERTICAL (WHERE PRACTICAL) FROM REGULATOR VENT TERMINUS
VENT TERMINUS UNDER FLAT OVERHANG	IF OVERHANG PROTRUDING LESS THAN 6 FEET VENT TERMINUS IS ACCEPTABLE UNDER OVERHANG.
CENTRAL A/C UNIT	36 INCHES PREFERRED / 18 FEET MINIMUM FROM GAS METER 36" FROM REGULATOR VENT TERMINUS
VENT TERMINUS UNDER AWNING/CANOPY WITH SIDES ENCLOSED	18 INCHES HORIZONTAL
FORCED AIR INTAKE LARGE RESIDENTIAL, COMMERCIAL OR INDUSTRIAL	REQUIRES ENGINEERING APPROVAL
VENT TERMINUS CLEARANCE ABOVE FINAL GRADE	18 INCHES PREFERRED / 12 INCHES MINIMUM
VENT TERMINUS CLEARANCE ABOVE KNOWN FLOOD LINE	18 INCHES PREFERRED / 12 INCHES MINIMUM
VENT TERMINUS TO A CATEGORY 1 DIRECT VENT HEATERS	3 FEET FROM INTAKE OR EXHAUST OR PER MFRG. SPECS. WHICHEVER IS GREATER
VENT TERMINUS TO SEWER VENT	18 INCHES RECOMMENDED

**TO CUSTOMER'S HOUSE LOAD**

AMERICAN 1813B2 WITH 9/16" DRIFICE  
250,000 BTU MAXIMUM OR

ITRON B-31R REGULATTOR WITH 1/2" DRIFICE  
400,000 BTU MAXIMUM

**TO CUSTOMER'S GENERATOR**  
14" W.C.  
650,000 BTU MAXIMUM



SYSTEM	REGULATOR
15 PSIG SYSTEM	FISHER CS 400IR REG.(SPRING CHANGE REQ'D) 1-1/2" SET @ 14" W.C. WITH 3/8" ORIFICE 15 PSIG MAX 9388986
60 PSIG SYSTEM	ITRON REGULATOR (SPRING CHANGE REQ'D) 1-1/4" SET @ 14" W.C. WITH 3/16" ORIFICE 60 PSIG MAX (ITEM ID 9342206)
99/124 PSIG SYSTEM	ITRON REGULATOR (SPRING CHANGE REQ'D) 1-1/4" SET @ 14" W.C. WITH 1/8" ORIFICE 124 PSIG MAX (ITEM ID 9383127)

REFERENCES

STD. DWGS.

SPECS.



LONG ISLAND & NEW YORK CITY

OUTDOOR METER SET – NO BYPASS  
WITH GENERATOR CLASS 750/800/1000  
425–1000 CFH – 15–124 PSIG SVCS

REVISIONS

DATE: NOV. 15, 2015

EFFECTIVE DATE: NOV. 15, 2015

DESIGN: PAUL GUGLIOTTA

STD. DWG.

DRAWN: PAUL GUGLIOTTA

NO. 000–000

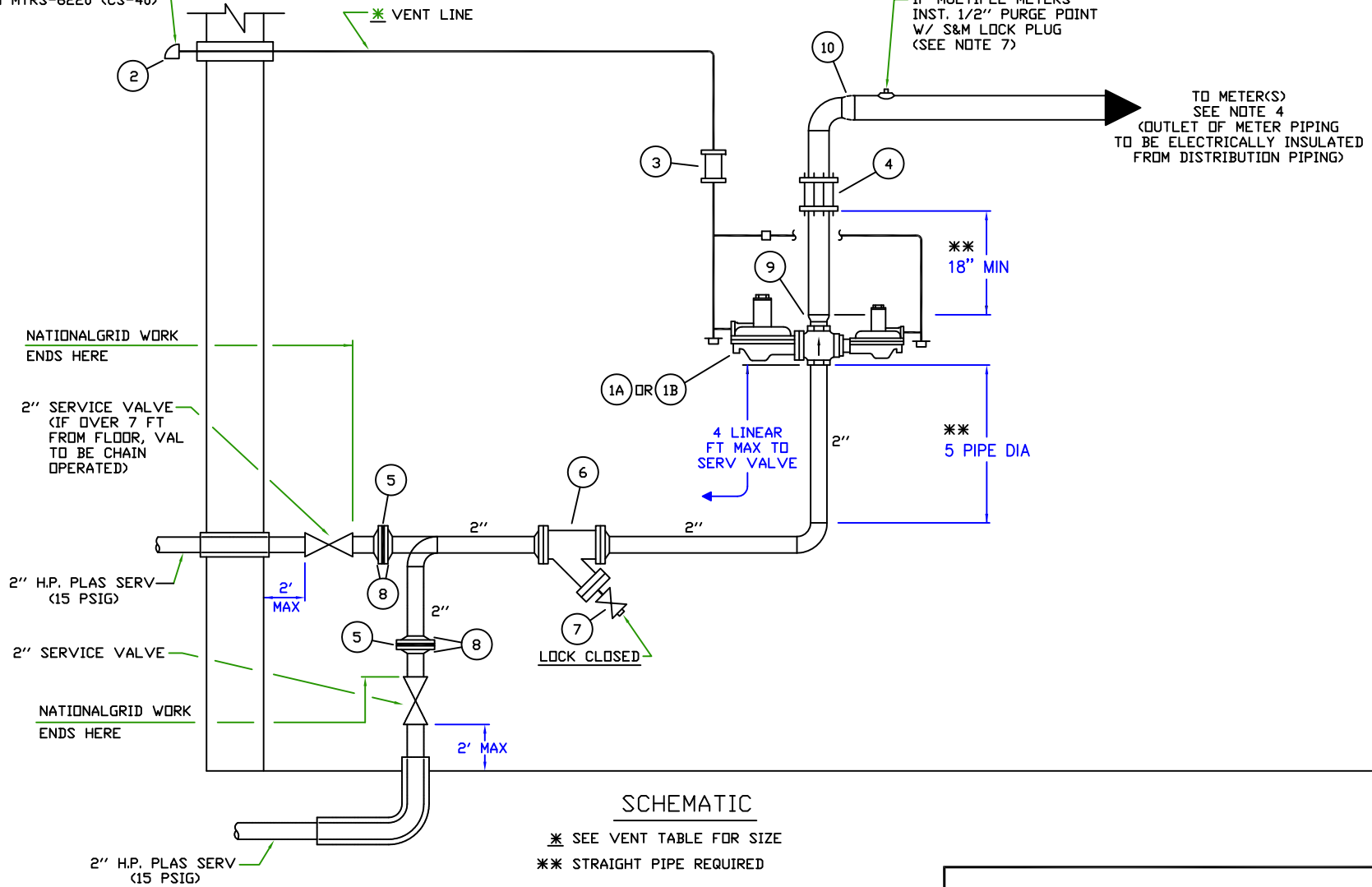
INDEX OF MOST FREQUENTLY USED SANDARDS IN NEW YORK CITY:

DRAWING #	TITLE
CS-MET005	M&R DRAWING FOR FISHER CS-803 THREADED REGULATOR INSIDE SET 15 PSIG INLET UP TO 9,080 CFH
CS-MET006	M&R DRAWING FOR FISHER CS-803 FLANGED REGULATOR INSIDE SET 15 PSIG INLET UP TO 9,080 CFH
CS-MET007	M&R DRAWING FOR FISHER CS-803 THREADED REGULATOR OUTSIDE SET 15 PSIG INLET UP TO 9,080 CFH
CS-MET008	M&R DRAWING FOR FISHER CS-803 FLANGED REGULATOR OUTSIDE SET 15 PSIG INLET UP TO 9,080 CFH
CS-MET009	M&R DRAWING FOR FISHER CS-803 THREADED REGULATOR INSIDE SET 60 PSIG INLET UP TO 17,370 CFH
CS-MET010	M&R DRAWING FOR FISHER CS-803 FLANGED REGULATOR INSIDE SET 60 PSIG INLET UP TO 17,370 CFH
CS-MET011	M&R DRAWING FOR FISHER CS-803 THREADED REGULATOR OUTSIDE SET 60 PSIG INLET UP TO 17,370 CFH
CS-MET012	M&R DRAWING FOR FISHER CS-803 FLANGED REGULATOR OUTSIDE SET 60 PSIG INLET UP TO 17,370 CFH
CS-MET013	PRESSURE SWITCH DETAILS FOR BOOSTER INSTALLATIONS
MTRS6010-NYC	TYPICAL DOMESTIC REGULATOR AND METER INSTALLATION - 60 LB. SYSTEM (1 AND 2 FAMILY DWELLINGS).
MTRS-6020-NYC	TYPICAL HIGH PRESSURE 60 LB. MULTIPLE SET (3 METER MAX.) , OUTSIDE INSTALLATION
MTRS-6030-NYC	TYPICAL LOW PRESSURE MULTIPLE SET (3 METER MAX. ), OUTSIDE INSTALLATION
MTRS-6050-NYC	TYPICAL DOMESTIC REGULATOR AND METER INSTALLATION 15 LB. SYSTEM (1 AND 2 FAMILY DWELLING) FOR 0-775 CFH FLOW
MTRS-6060 -NYC	INSTALLATION OF PROTECTION POST FOR OUTSIDE METER SETS
MTRS-6070-NYC	SINGLE INSIDE METER INSTALLATION 0 - 250 CFH AND 0 - 425 CFH RANGE LOW PRESSURE.
MTRS6071-NYC	MULTI INSIDE METER INSTALLATION 0 - 250 CFH AND 0 - 425 CFH RANGE LOW PRESSURE.
MTRS-6080-NYC	SIAMESE INSIDE METER INSTALLATION 0 - 425 - CFH RANGE - LOW PRESSURE.
MTRS-6081-NYC	SIAMESE INSIDE METER INSTALLATION 0 - 250 CFH RANGE - LOW PRESSURE.
MTRS6110-NYC	SINGLE ROTARY METER FOR INSIDE - OUTSIDE INSTALLATION 31 CFH - 7810 CFH RANGE LOW PRESSURE.
MTRS6130-NYC	H.P. ROTARY METER REGULATOR SET 15 PSIG 775-1550 CFH AND 60 PSIG 470-940 CFH RANGE INDOOR - OUTDOOR SET



MTRS6140-LI-NYC	SINGLE METER AND REGULATOR INSTALLATION, OUTSIDE SET, 1/2 IN. AND 3/4 IN. DIAMETER SERVICES OPERATING AT 15 - 124 PSIG, 0 - 250 CFH , 0 - 425 AND 0-630 CFH RANGE
MTRS6142-LI-NYC	SINGLE METER AND REGULATOR INSTALLATION OUTSIDE SET, 1 IN. AND 1-1/4 IN. DIAMETER SERVICES OPERATING AT 15 - 124 PSIG, 0 - 250 CFH, 0 - 425 AND 0-630 CFH RANGE
MTRS6150-NYC	LOW PRESSURE SINGLE METER OUTSIDE INSTALLATION 0 - 250 CFH AND 0 - 425 CFH RANGE.
MTRS-6170-NYC	SINGLE INSIDE METER INSTALLATION WITH OUTSIDE REGULATOR, 60 PSIG HP SERVICE, 0-250 CFH AND 0-425 CFH RANGE
MTRS-6180-NYC	SINGLE INSIDE METER INSTALLATION WITH OUTSIDE REGULATOR, 0-250 CFH AND 0-425 CFH RANGE 15 PSIG HP SERVICE
MTRS-6190-NYC	RECOMMENDED HP AND LP METER PIPING INSTALLATION FOR MULTIPLE RATE INSTALLATIONS.
MTRS6200-NYC	TYPICAL METER SET ON INDIVIDUAL BUILDING FLOORS
MTRS-6220-NYC	VENT ASSEMBLY DETAILS.
020013-CS	OUTDOOR LOCATION FOR REGULATOR AND RELIEF VALVE VENT TERMINUS

FOR DETAILS SEE  
STD DWG MTRS-6220 (CS-40)



**SCHEMATIC**

\* SEE VENT TABLE FOR SIZE  
\*\* STRAIGHT PIPE REQUIRED

**NOTES & BILL OF MATERIAL ON REVERSE SIDE**

NOTE: FOR VENT PIPING IN EXCESS OF 100' CONTACT  
SYSTEM DESIGN SECTION FOR CORRECT PIPE SIZE.

**nationalgrid**

NYC

**M & R DRAWING FOR FISHER CS-803 THREADED  
REGULATOR - INSIDE SET  
15 PSIG INLET - UP TO 9,080 CFH**

DATE: 11/15/2012

EFFECTIVE DATE: 09/15/2013

DESIGN: PAT O NEIL

STD. DWG.

DRAWN: PAT O NEIL

NO. **CS-MET005**

* VENT PIPE SIZE TABLE	
TOTAL LEN.	NOMINAL SIZE
0 - 50'	1-1/2"
0 - 100'	2"

THIS DRAWING CONFORMS TO:	
1	PUBLIC SERVICE COMM., CODES, RULES & REGULATIONS TRANS. & DIST. OF GAS SAFETY - 16NYCRR PART 255 & 261
2	N.Y.C. ADMINISTRATION CODE TITLE 27 & RS-16 SECT. P115.
REVISION: CHANGED ORACLE ITEM ID'S TO SAP ID'S	

BILL OF MATERIAL					
NO.	ITEM	SIZE	QUAN.	BY	STOCK NO.
<b>CAPACITY UP TO 4,990 CFH</b>					
1A	REGULATOR, FISHER CS803IT-LIN W/INTEGRAL TRUE-MONITER TM600 MODULE, SHROUD (BLUE) #GE29773X032, 5/8" ORIFICE, SCREWED MAIN SP. (BROWN) #GE49043X012, SP. RANGE 5.5" - 8.5" W.C., SET AT 6" W.C MONITOR SP. (GREEN) #GE30196X012, SP. RANGE 18" - 30" W.C., SET AT 21" W.C.	2"	1	NATIONALGRID	9386778
<b>CAPACITY 4,991 TO 9,080 CFH</b>					
1B	REGULATOR, FISHER CS803IT-LIN W/INTEGRAL TRUE-MONITER TM600 MODULE, SHROUD (BLUE) #GE29773X032, 7/8" ORIFICE, SCREWED MAIN SP. (BROWN) #GE49043X012, SP. RANGE 5.5" - 8.5" W.C., SET AT 6" W.C MONITOR SP. (GREEN) #GE30196X012, SP. RANGE 18" - 30" W.C., SET AT 21" W.C.	2"	1	NATIONALGRID	9386779
2	VENT ASSEMBLY, WITH RAIN AND INSECT RESISTANT SCREEN (FOR CORRECT VENT ASSEMBLY SIZE SEE VENT & RELIEF TABLE ON FRONT SIDE)	1-1/2" 2"	1	CUSTOMER	9358641 9358636
3	COMPRESSION COUPLING, DRESSER STYLE 90, INSULATING (FOR VENT PIPING IN EXCESS OF 100' CONTACT SYSTEM DESIGN SECT. FOR CORRECT COUPLING SIZE)	1-1/2" 2"	1	CUSTOMER	9341465 9341468
4	COMPRESSION COUPLING, DRESSER STYLE 90 (FOR CORRECT COUPLING SIZE SEE PIPE SIZE TABLE BELOW) COMPRESSION COUPLING, DRESSER STYLE 38 COMPRESSION COUPLING, DRESSER STYLE 38	2" 3" 4"	1 1 1	CUSTOMER	9341517 9341476 9341622
5	INSUL. KIT FOR 150# ANSI F-F STEEL FLANGE	2"	1	CUSTOMER	9340992
6	STRAINER, MUESSCO "Y" OR EQ.	2"	1	CUSTOMER	9340158
7	VALVE, LOCKWING, MUELLER TAMP-R-LOK H11119B LOCK CLOSED OR EQ.	1-1/4"	1	CUSTOMER	-----
8	FLANGE, 150# ANSI F-F STEEL, WELD NECK OR SCREWED	2"	2	CUSTOMER	-----
9	FORGED STEEL CONCENTRIC REDUCER OR SCREWED FITTING (TO BE DETERMINED BY PIPE SIZE TABLE BELOW - SEE NOTE 8)	----	1	CUSTOMER	-----
10	FORGED STEEL CONCENTRIC REDUCER OR SCREWED FITTING (SEE NOTE 9)	----	1	CUSTOMER	-----

RECOMMENDATED PIPE SIZE AT OUTLET OF REGUALTOR	
CAPACITY IN CFH	PIPE SIZE
UP TO 3,000	2"
3,001 - 5,000	3"
5,001 - 9,080	4"

**NOTES**

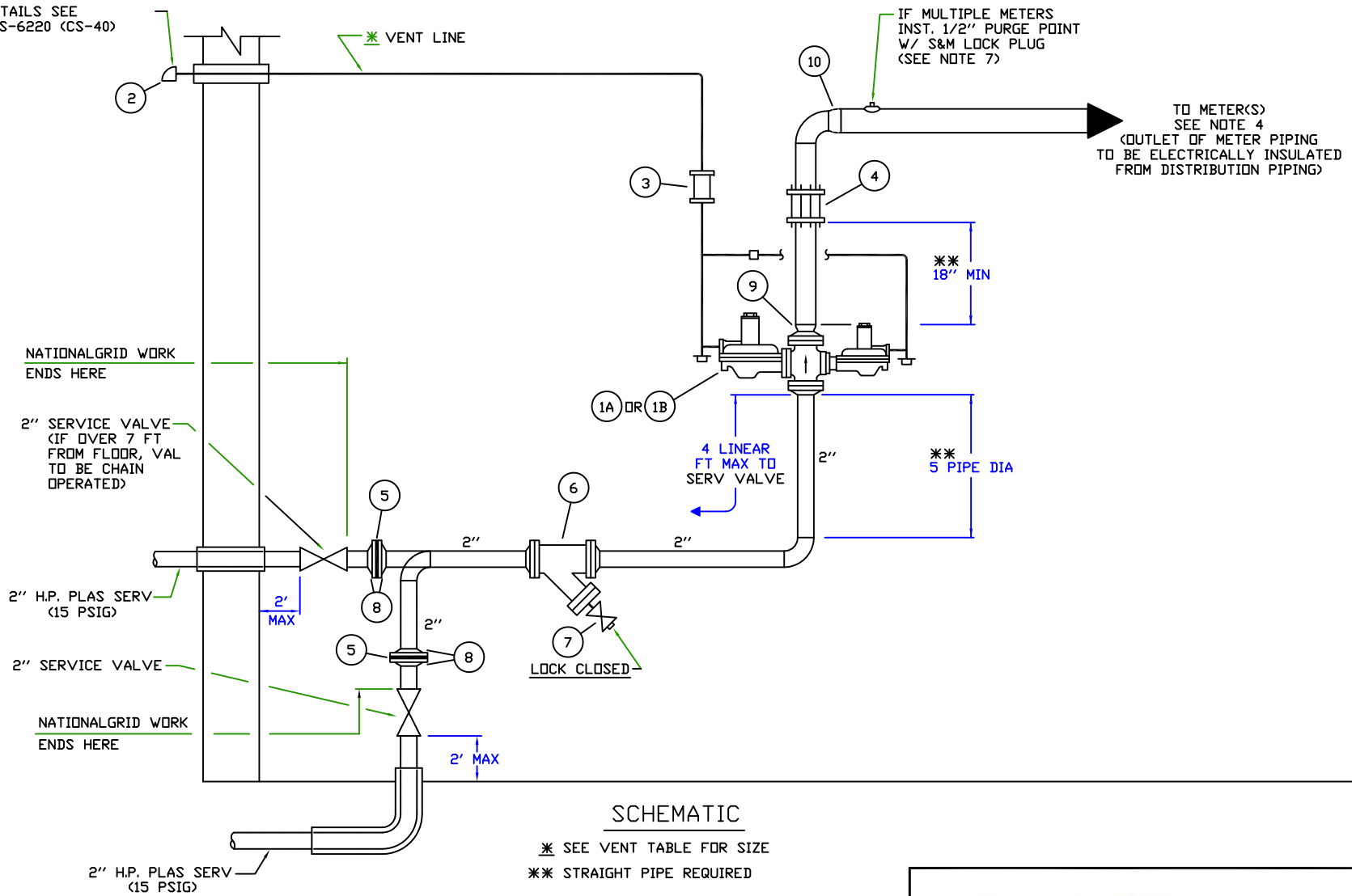
1. PILOT GAS FROM FIRM LOAD METER - IF REQUIRED.
2. PROVIDE ADEQUATE SPACING AROUND METER (FROM SURROUNDING PIPING & PARTITIONS) TO PERMIT REMOVAL & MAINTENANCE. PROVIDE 5 FT CLEAR SPACE IN FRONT OF METER.
3. ALL CLOSE/ALL THREADED NIPPLES, IF USED MUST BE EX-HEAVY, ALL VENT PIPING & FITTINGS TO BE STANDARD WALL THICKNESS.
4. TEMPERATURE COMPENSATED METERS ARE TO BE INSTALLED IN ALL OUTDOOR LOCATIONS OR WHERE THE METER IS EXPOSED TO TEMPERATURES EQUIVALENT TO AN OUTDOOR ENVIRONMENT.
5. ALL FLANGES TO BE SUPPLIED BY CUSTOMER. FLANGES TO BE STEEL & COMPATIBLE IN TYPE & PRESS. RATING WITH MATING FLANGE. FLANGES SHALL BE WELD NECK OR THREADED END AS SPECIFIED IN BILL OF MATERIALS; SLIP-ON FLANGES ARE NOT PERMITTED. WHERE MATERIAL IS NOT SPECIFIED, WELD NECK FLANGES SHALL BE USED UNLESS PIPE DIA. & PRESS. CONDITIONS PERMIT THE INSTALLATION OF SCREWED FITTINGS.
6. DO NOT WELD WITH METER IN LINE USE SPOOL PIECE.
7. ALL THREADOLETS TO BE INSTALLED ON STRAIGHT PIPE, NOT ON FITTINGS. A SCREWED REDUCING TEE MAY BE USED AS AN ALTERNATIVE TO A THREADOLET.
8. FORGED STEEL CONCENTRIC REDUCER OR SCREWED FITTING (ITEM 9), IF REQUIRED, TO BE INSTALLED DIRECTLY AT THE OUTLET OF THE REGULATOR.
9. SIZE OF REDUCER (ITEM 10), IF REQUIRED, TO BE DETERMINED BY DISTRIBUTION (HOUSE) PIPING DESIGN OF CUSTOMER'S CONTRACTOR.

**SPECIAL NOTE:** METER INSTALLATION AT ALL TIMES SHALL BE CLEAN, DRY, FREE FROM STEAM, CHEMICAL FUMES & A MINIMUM OF 3 FT. FROM SOURCES OF IGNITION, SUCH AS ELECTRIC RELAYS, SWITCHES, MOTOR STARTERS INCLUDING OIL OR GAS FIRED FURNACES & WATER HEATERS. INSTALLATIONS SHALL CONFORM TO NEW YORK STATE PSC CODE TITLE 16 PART 255 & 261 AND NEW YORK CITY BUILDING CODE TITLE 27 & RS-16 SECT. P115.

**ALL INSTALLATIONS**

- A) ALL PIPING SHALL CONFORM TO & BE TESTED ACCORDING TO THE NEW YORK CITY ADMIN. CODE, & NATIONALGRID SPECIFICATIONS.
- B) NO CAST IRON FITTINGS SHALL BE USED EXCEPT VALVES, REGULATORS, METERS, RELIEF VAL., AUTOMATIC SHUT-OFF VAL. & STRAINERS.
- C) DIAPHRAGMS OF ALL REGULATORS AND SAFETY DEVICES TO BE PROTECTED DURING PRESSURE TESTS.
- D) DO NOT USE BUSHINGS EXCEPT AS NOTED.
- E) REGULATOR TO BE INSTALLED WITH "FLOW ARROW" ON BODY AS SHOWN ON DRAWING.
- F) MISC. PIPE, FIT., BOLTS, NUTS, GASKETS, ANCHORAGE ASSEMBLIES, ETC., NOT LISTED TO BE FURNISHED & INST. BY CUSTOMER'S PLUMBER.
- G) ALL FACTORY THREADED FITTINGS ETC., TO BE THOROUGHLY CLEANED OF ALL FOREIGN MATERIAL BEFORE BEING INSTALLED.
- H) ALL PIPING TO HAVE NECESSARY SUPPORTS AND BRACES TO NON-METALLIC STRUCTURES & TO BE ELECTRICALLY INSULATED. SCHEMATIC DOES NOT EXHIBIT ALL PIPELINE SUPPORT NEEDS. INSTALL ADDITIONAL SUPPORTS & BRACES AS REQUIRED.
- J) NATIONALGRID SHALL NOT BE RESPONSIBLE FOR FITTING DIMENSIONS OR FOR SCALED DIMENSIONS.
- K) PREVENT ELECTRICAL SHORT BETWEEN GAS SERVICE ENTRANCE AND METER OUTLET.
- L) ALL VENT HEADS SHALL BE LOCATED A MIN OF 6' ABOVE GRADE FOR NON-DOMESTIC INST & 18" MIN ABOVE GRADE FOR DOMESTIC INST. DO NOT LOCATE NEAR ANY BUILDING OPENING, WINDOW, DOOR ETC. PLACE MARKER WORDED "GAS VENT" AT EACH VENT. VENT TO BE RAIN RESISTANT WITH APPROVED SCREEN.
- M) WHERE PRESS. OF MORE THAN 3 PSI IS FURNISHED THE CUSTOMER MUST OBTAIN SPECIAL PERMISSION FROM THE COMMISSIONER. (NYC ADMIN. CODE - GAS PIPING). PIPING OVER 1/2 PSI SHALL ALSO CONFORM TO ANSI CODES B31.2 - 1968.

FOR DETAILS SEE  
STD DWG MTRS-6220 (CS-40)



NOTES & BILL OF MATERIAL ON REVERSE SIDE

NOTE: FOR VENT PIPING IN EXCESS OF 100' CONTACT SYSTEM DESIGN SECTION FOR CORRECT PIPE SIZE.

* VENT PIPE SIZE TABLE	
TOTAL LEN.	NOMINAL SIZE
0 - 50'	1-1/2"
0 - 100'	2"

THIS DRAWING CONFORMS TO:	
1	PUBLIC SERVICE COMM., CODES, RULES & REGULATIONS TRANS., & DIST. OF GAS SAFETY - 16NYCRR PART 255 & 261
2	N.Y.C. ADMINISTRATION CODE TITLE 27 & RS-16 SECT. P115.
REVISION: UPDATED ITEMS USING SAP ITEM ID'S	

**nationalgrid**

NYC

**M & R DRAWING FOR FISHER CS-803  
FLANGED REGULATOR - INSIDE SET  
15 PSIG INLET - UP TO 9,080 CFH**

DATE: 11/15/2012

EFFECTIVE DATE: 09/15/2013

DESIGN: PAT O NEIL

STD. DWG.

DRAWN: PAT O NEIL

NO.

**CS-MET006**

**BILL OF MATERIAL**

NO.	ITEM	SIZE	QUAN.	BY	STOCK NO.
<b>CAPACITY UP TO 4,990 CFH</b>					
1A	REGULATOR, FISHER CS803IT-LIN W/INTEGRAL TRUE-MONITER TM600 MODULE, SHROUD (BLUE) #GE29773X032, 5/8" ORIFICE, F-F FLANGED MAIN SP. (BROWN) #GE49043X012, SP. RANGE 5.5" - 8.5" W.C., SET AT 6" W.C. MONITOR SP. (GREEN) #GE30196X012, SP. RANGE 18" - 30" W.C., SET AT 21" W.C.	2"	1	NATIONALGRID	9386780
<b>CAPACITY 4,991 TO 9,080 CFH</b>					
1B	REGULATOR, FISHER CS803IT-LIN W/INTEGRAL TRUE-MONITER TM600 MODULE, SHROUD (BLUE) #GE29773X032, 7/8" ORIFICE, F-F FLANGED MAIN SP. (BROWN) #GE49043X012, SP. RANGE 5.5" - 8.5" W.C., SET AT 6" W.C. MONITOR SP. (GREEN) #GE30196X012, SP. RANGE 18" - 30" W.C., SET AT 21" W.C.	2"	1	NATIONALGRID	9386793
2	VENT ASSEMBLY, WITH RAIN AND INSECT RESISTANT SCREEN (FOR CORRECT VENT ASSEMBLY SIZE SEE VENT & RELIEF TABLE ON FRONT SIDE)	1-1/2" 2"	1	CUSTOMER	9358641 9358636
3	COMPRESSION COUPLING, DRESSER STYLE 90, INSULATING (FOR VENT PIPING IN EXCESS OF 100' CONTACT SYSTEM DESIGN SECT. FOR CORRECT COUPLING SIZE)	1-1/2" 2"	1	CUSTOMER	9341465 9341468
4	COMPRESSION COUPLING, DRESSER STYLE 90 (FOR CORRECT COUPLING SIZE COMPRESSION COUPLING, DRESSER STYLE 38 SEE PIPE SIZE TABLE BELOW) COMPRESSION COUPLING, DRESSER STYLE 38	2" 3" 4"	1 1 1	CUSTOMER	9341517 9385252 9341622
5	INSUL. KIT FOR 150# ANSI F-F STEEL FLANGE	2"	1	CUSTOMER	9340992
6	STRAINER, MUESSCO "Y" OR EQ.	2"	1	CUSTOMER	9340158
7	VALVE, LOCKWING, MUELLER TAMP-R-LOK H11119B LOCK CLOSED OR EQ.	1-1/4"	1	CUSTOMER	----
8	FLANGE, 150# ANSI F-F STEEL, WELD NECK OR SCREWED	2"	2	CUSTOMER	----
9	FORGED STEEL CONCENTRIC REDUCER OR SCREWED FITTING (TO BE DETERMINED BY PIPE SIZE TABLE BELOW - SEE NOTE 8)	---	1	CUSTOMER	----
10	FORGED STEEL CONCENTRIC REDUCER OR SCREWED FITTING (SEE NOTE 9)	---	1	CUSTOMER	----

RECOMMENDATED PIPE SIZE AT OUTLET OF REGUALTOR	
CAPACITY IN CFH	PIPE SIZE
UP TO 3,000	2"
3,001 - 5,000	3"
5,001 - 9,080	4"

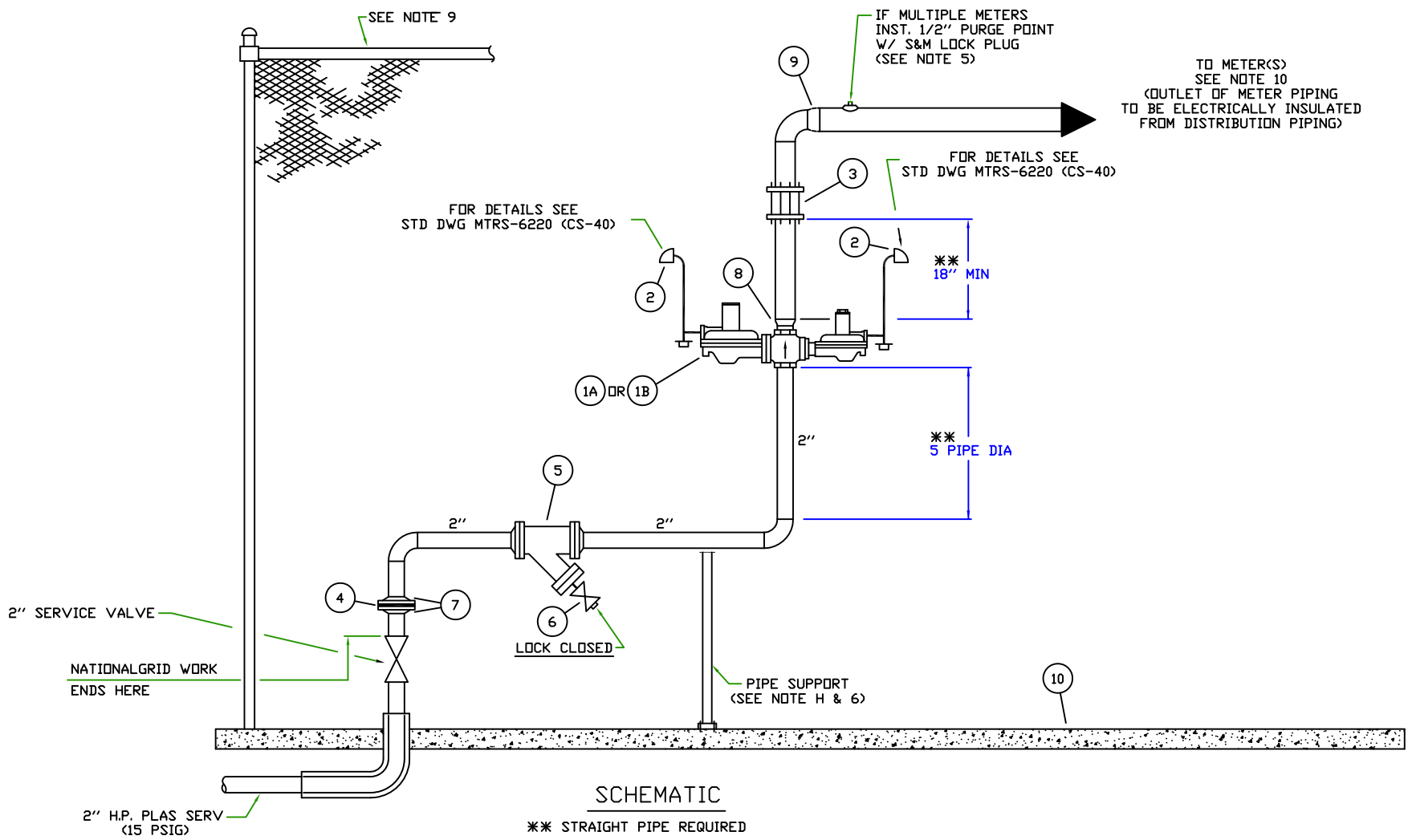
**NOTES**

- PILOT GAS FROM FIRM LOAD METER - IF REQUIRED.
- PROVIDE ADEQUATE SPACING AROUND METER (FROM SURROUNDING PIPING & PARTITIONS) TO PERMIT REMOVAL & MAINTENANCE. PROVIDE 5 FT CLEAR SPACE IN FRONT OF METER.
- ALL CLOSE/ALL THREADED NIPPLES, IF USED MUST BE EX-HEAVY, ALL VENT PIPING & FITTINGS TO BE STANDARD WALL THICKNESS.
- TEMPERATURE COMPENSATED METERS ARE TO BE INSTALLED IN ALL OUTDOOR LOCATIONS OR WHERE THE METER IS EXPOSED TO TEMPERATURES EQUIVALENT TO AN OUTDOOR ENVIRONMENT.
- ALL FLANGES TO BE SUPPLIED BY CUSTOMER. FLANGES TO BE STEEL & COMPATIBLE IN TYPE & PRESS. RATING WITH MATING FLANGE. FLANGES SHALL BE WELD NECK OR THREADED END AS SPECIFIED IN BILL OF MATERIALS; SLIP-ON FLANGES ARE NOT PERMITTED. WHERE MATERIAL IS NOT SPECIFIED, WELD NECK FLANGES SHALL BE USED UNLESS PIPE DIA. & PRESS. CONDITIONS PERMIT THE INSTALLATION OF SCREWED FITTINGS.
- DO NOT WELD WITH METER IN LINE USE SPOOL PIECE.
- ALL THREDOLETS TO BE INSTALLED ON STRAIGHT PIPE, NOT ON FITTINGS. A SCREWED REDUCING TEE MAY BE USED AS AN ALTERNATIVE TO A THREDOLET.
- FORGED STEEL CONCENTRIC REDUCER OR SCREWED FITTING (ITEM 9), IF REQUIRED, TO BE INSTALLED DIRECTLY AT THE OUTLET OF THE REGULATOR.
- SIZE OF REDUCER (ITEM 10), IF REQUIRED, TO BE DETERMINED BY DISTRIBUTION (HOUSE) PIPING DESIGN OF CUSTOMER'S CONTRACTOR.

**SPECIAL NOTE:** METER INSTALLATION AT ALL TIMES SHALL BE CLEAN, DRY, FREE FROM STEAM, CHEMICAL FUMES & A MINIMUM OF 3 FT. FROM SOURCES OF IGNITION, SUCH AS ELECTRIC RELAYS, SWITCHES, MOTOR STARTERS INCLUDING OIL OR GAS FIRED FURNACES & WATER HEATERS. INSTALLATIONS SHALL CONFORM TO NEW YORK STATE PSC CODE TITLE 16 PART 255 & 261 AND NEW YORK CITY BUILDING CODE TITLE 27 & RS-16 SECT. P115.

**ALL INSTALLATIONS**

- ALL PIPING SHALL CONFORM TO & BE TESTED ACCORDING TO THE NEW YORK CITY ADMIN. CODE, & NATIONALGRID SPECIFICATIONS.
- NO CAST IRON FITTINGS SHALL BE USED EXCEPT VALVES, REGULATORS, METERS, RELIEF VAL., AUTOMATIC SHUT-OFF VAL. & STRAINERS.
- DIAPHRAGMS OF ALL REGULATORS AND SAFETY DEVICES TO BE PROTECTED DURING PRESSURE TESTS.
- DO NOT USE BUSHINGS EXCEPT AS NOTED.
- REGULATOR TO BE INSTALLED WITH "FLOW ARROW" ON BODY AS SHOWN ON DRAWING.
- MISC. PIPE, FIT., BOLTS, NUTS, GASKETS, ANCHORAGE ASSEMBLIES, ETC., NOT LISTED TO BE FURNISHED & INST. BY CUSTOMER'S PLUMBER.
- ALL FACTORY THREADED FITTINGS ETC., TO BE THOROUGHLY CLEANED OF ALL FOREIGN MATERIAL BEFORE BEING INSTALLED.
- ALL PIPING TO HAVE NECESSARY SUPPORTS AND BRACES TO NON-METALLIC STRUCTURES & TO BE ELECTRICALLY INSULATED. SCHEMATIC DOES NOT EXHIBIT ALL PIPELINE SUPPORT NEEDS. INSTALL ADDITIONAL SUPPORTS & BRACES AS REQUIRED.
- NATIONALGRID SHALL NOT BE RESPONSIBLE FOR FITTING DIMENSIONS OR FOR SCALED DIMENSIONS.
- PREVENT ELECTRICAL SHORT BETWEEN GAS SERVICE ENTRANCE AND METER OUTLET.
- ALL VENT HEADS SHALL BE LOCATED A MIN OF 6' ABOVE GRADE FOR NON-DOMESTIC INST & 18" MIN ABOVE GRADE FOR DOMESTIC INST. DO NOT LOCATE NEAR ANY BUILDING OPENING, WINDOW, DOOR ETC. PLACE MARKER WORDED "GAS VENT" AT EACH VENT. VENT TO BE RAIN RESISTANT WITH APPROVED SCREEN.
- WHERE PRESS. OF MORE THAN 3 PSI IS FURNISHED THE CUSTOMER MUST OBTAIN SPECIAL PERMISSION FROM THE COMMISSIONER. (NYC ADMIN. CODE - GAS PIPING). PIPING OVER 1/2 PSI SHALL ALSO CONFORM TO ANSI CODES B31.2 - 1968.



SCHEMATIC

\*\* STRAIGHT PIPE REQUIRED

NOTE: FOR VENT PIPING IN EXCESS OF 100' CONTACT SYSTEM DESIGN SECTION FOR CORRECT PIPE SIZE.

* VENT PIPE SIZE TABLE	
TOTAL LEN.	NOMINAL SIZE
0 - 50'	1-1/2"
0 - 100'	2"

THIS DRAWING CONFORMS TO:	
1	PUBLIC SERVICE COMM., CODES, RULES & REGULATIONS TRANS. & DIST. OF GAS SAFETY - 16NYCRR PART 255 & 261
2	N.Y.C. ADMINISTRATION CODE TITLE 27 & RS-16 SECT. P115.
REVISION: UPDATED PAGE 2 WITH NEW SAP ITEM ID'S	

**nationalgrid**  
NYC

**M & R DRAWING FOR FISHER CS-803  
THREADED REGULATOR - OUTSIDE SET  
15 PSIG INLET - UP TO 9,080 CFH**

DATE: 11/15/2012	EFFECTIVE DATE: 09/15/2013
DESIGN: PAT O NEIL	STD. DWG. NO. <b>CS-MET007</b>
DRAWN: PAT O NEIL	

BILL OF MATERIAL

NO.	ITEM	SIZE	QUAN.	BY	STOCK NO.
<b>CAPACITY UP TO 4,990 CFH</b>					
1A	REGULATOR, FISHER CS803IT-LIN W/INTEGRAL TRUE-MONITER TM600 MODULE, SHROUD (BLUE) #GE29773X032, 5/8" ORIFICE, SCREWED MAIN SP. (BROWN) #GE49043X012, SP. RANGE 5.5" - 8.5" W.C., SET AT 6" W.C MONITOR SP. (GREEN) #GE30196X012, SP. RANGE 18" - 30" W.C., SET AT 21" W.C.	2"	1	NATIONALGRID	9386778
<b>CAPACITY 4,991 TO 9,080 CFH</b>					
1B	REGULATOR, FISHER CS803IT-LIN W/INTEGRAL TRUE-MONITER TM600 MODULE, SHROUD (BLUE) #GE29773X032, 7/8" ORIFICE, SCREWED MAIN SP. (BROWN) #GE49043X012, SP. RANGE 5.5" - 8.5" W.C., SET AT 6" W.C MONITOR SP. (GREEN) #GE30196X012, SP. RANGE 18" - 30" W.C., SET AT 21" W.C.	2"	1	NATIONALGRID	9386779
2	VENT ASSEMBLY, WITH RAIN AND INSECT RESISTANT SCREEN	1"	2	CUSTOMER	9358640
3	COMPRESSION COUPLING, DRESSER STYLE 90	2"	1	CUSTOMER	9341517
	COMPRESSION COUPLING, DRESSER STYLE 38 (FOR CORRECT COUPLING SIZE SEE PIPE SIZE TABLE BELOW)	3"	1		9385252
	COMPRESSION COUPLING, DRESSER STYLE 38	4"	1		9341622
4	INSUL. KIT FOR 150# ANSI F-F STEEL FLANGE	2"	1	CUSTOMER	9340992
5	STRAINER, MUESSCO "Y" OR EQ.	2"	1	CUSTOMER	9340158
6	VALVE, LOCKWING, MUELLER TAMP-R-LOK H11119B LOCK CLOSED OR EQ.	1-1/4"	1	CUSTOMER	----
7	FLANGE, 150# ANSI F-F STEEL, WELD NECK OR SCREWED	2"	2	CUSTOMER	----
8	FORGED STEEL CONCENTRIC REDUCER OR SCREWED FITTING (TO BE DETERMINED BY PIPE SIZE TABLE BELOW - SEE NOTE 11)	---	1	CUSTOMER	----
9	FORGED STEEL CONCENTRIC REDUCER OR SCREWED FITTING (SEE NOTE 12)	---	1	CUSTOMER	----
10	CONCRETE PAD FOR METER, 4" THICK, 5' WIDE, LENGTH DETERMINED BY LENGTH OF THE METER AND REGULATOR RUN	---	1	CUSTOMER	----

RECOMMENDATED PIPE SIZE AT OUTLET OF REGULATOR	
CAPACITY IN CFH	PIPE SIZE
UP TO 3,000	2"
3,001 - 5,000	3"
5,001 - 9,080	4"

**NOTES**

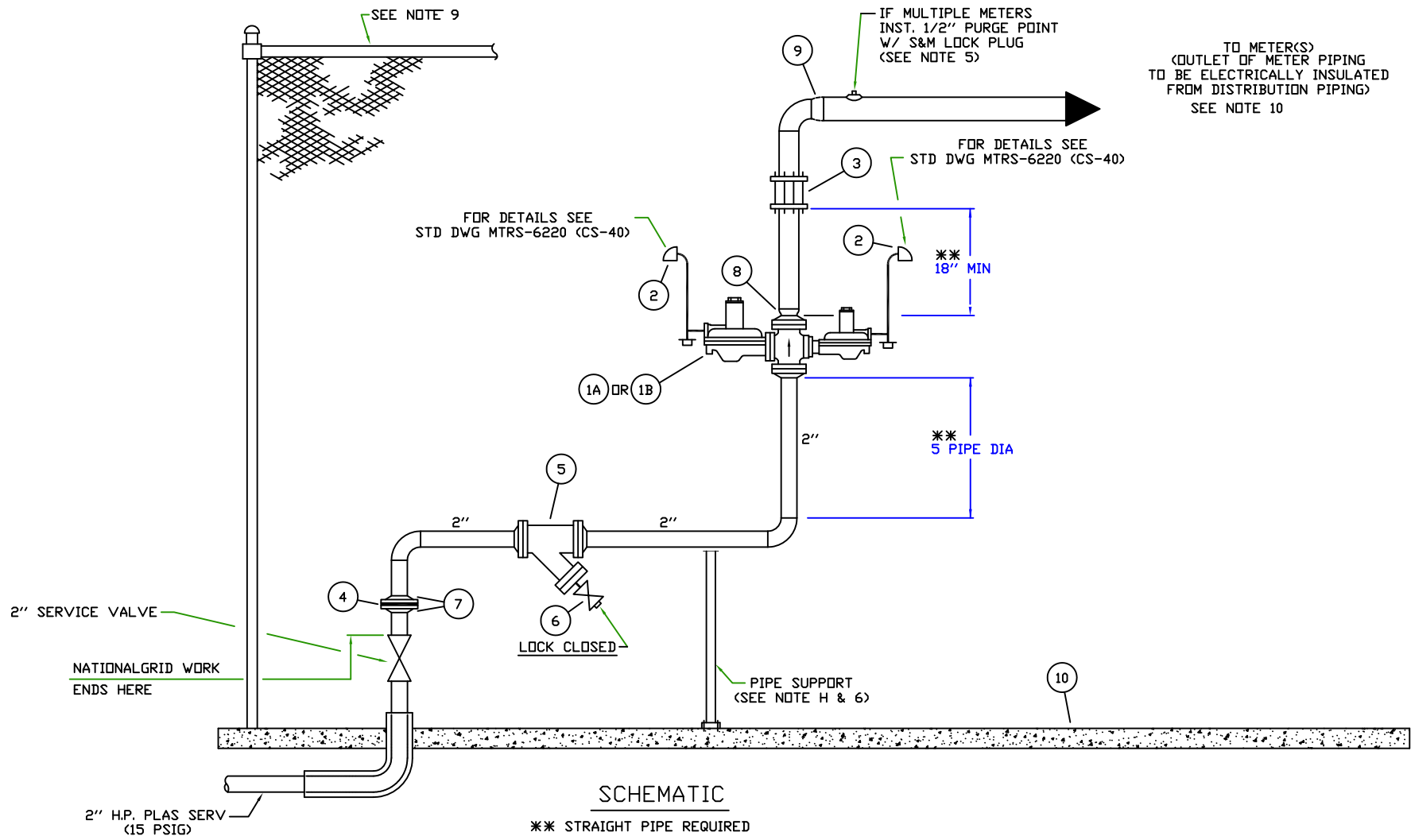
- PILOT GAS FROM FIRM LOAD METER - IF REQUIRED.
- PROVIDE ADEQUATE SPACING AROUND METER (FROM SURROUNDING PIPING & PARTITIONS) TO PERMIT REMOVAL & MAINTENANCE. PROVIDE 5 FT CLEAR SPACE IN FRONT OF METER.
- COAT PIPE & NON-GALVANIZED FITTINGS WITH RUSTOLEUM #7715. TWO COATS REQUIRED, BRUSH APPLIED.
- DO NOT WELD WITH METER IN LINE - USE SPOOL PIECE.
- ALL THREDOLETS TO BE INSTALLED ON STRAIGHT PIPE, NOT ON FITTINGS. A SCREWED REDUCING TEE MAY BE USED AS AN ALTERNATIVE TO A THREDOLET.
- VERTICAL PIPE SUPPORTS SHALL BE ADEQUATELY SEALED FROM WATER INFILTRATION & PROPERLY COATED TO RESIST CORROSION.
- SIZE OF REDUCER (ITEM 8), IF REQUIRED, TO BE DETERMINED BY DISTRIBUTION (HOUSE) PIPING DESIGN OF CUSTOMER'S CONTRACTOR.
- IF METERING INSTALLATION IS IN CLOSE PROXIMITY TO VEHICULAR TRAFFIC, INSTALL DEADMEN OUTSIDE FENCED METER AREA.
- A FULLY ENCLOSED (INCLUDING TOP) CHAIN LINK FENCE (CYCLONE) MIN. 8 FT. HIGH WITH GATE & LOCK IS REQUIRED ON ALL OUTSIDE SETS. TO BE SUPPLIED BY CUST.
- TEMPERATURE COMPENSATED METERS ARE TO BE INSTALLED IN ALL OUTDOOR LOCATIONS OR WHERE THE METER IS EXPOSED TO TEMPERATURES EQUIVALENT TO AN OUTDOOR ENVIRONMENT.
- FORGED STEEL CONCENTRIC REDUCER OR SCREWED FITTING (ITEM 8), IF REQUIRED, TO BE INSTALLED DIRECTLY AT THE OUTLET OF THE REGULATOR.
- SIZE OF REDUCER (ITEM 9), IF REQUIRED, TO BE DETERMINED BY DISTRIBUTION (HOUSE) PIPING DESIGN OF CUSTOMER'S CONTRACTOR.

**SPECIAL NOTE:** METER INSTALLATION AT ALL TIMES SHALL BE CLEAN, DRY, FREE FROM STEAM, CHEMICAL FUMES & A MINIMUM OF 3 FT. FROM SOURCES OF IGNITION, SUCH AS ELECTRIC RELAYS, SWITCHES, MOTOR STARTERS INCLUDING OIL OR GAS FIRED FURNACES & WATER HEATERS. INSTALLATIONS SHALL CONFORM TO NEW YORK STATE PSC CODE TITLE 16 PART 255 & 261 AND NEW YORK CITY BUILDING CODE TITLE 27 & RS-16 SECT. P115.

**ALL INSTALLATIONS**

- ALL PIPING SHALL CONFORM TO & BE TESTED ACCORDING TO THE NEW YORK CITY ADMIN. CODE, & NATIONALGRID SPECIFICATIONS.
- NO CAST IRON FITTINGS SHALL BE USED EXCEPT VALVES, REGULATORS, METERS, RELIEF VAL., AUTOMATIC SHUT-OFF VAL. & STRAINERS.
- DIAPHRAGMS OF ALL REGULATORS AND SAFETY DEVICES TO BE PROTECTED DURING PRESSURE TESTS.
- DO NOT USE BUSHINGS EXCEPT AS NOTED.
- REGULATOR TO BE INSTALLED WITH "FLOW ARROW" ON BODY AS SHOWN ON DRAWING.
- MISC. PIPE, FIT., BOLTS, NUTS, GASKETS, ANCHORAGE ASSEMBLIES, ETC., NOT LISTED TO BE FURNISHED & INST. BY CUSTOMER'S PLUMBER.
- ALL FACTORY THREADED FITTINGS ETC., TO BE THOROUGHLY CLEANED OF ALL FOREIGN MATERIAL BEFORE BEING INSTALLED.
- ALL PIPING TO HAVE NECESSARY SUPPORTS AND BRACES TO NON-METALLIC STRUCTURES & TO BE ELECTRICALLY INSULATED. SCHEMATIC DOES NOT EXHIBIT ALL PIPELINE SUPPORT NEEDS. INSTALL ADDITIONAL SUPPORTS & BRACES AS REQUIRED.
- NATIONALGRID SHALL NOT BE RESPONSIBLE FOR FITTING DIMENSIONS OR FOR SCALED DIMENSIONS.
- PREVENT ELECTRICAL SHORT BETWEEN GAS SERVICE ENTRANCE AND METER OUTLET.
- ALL VENT HEADS SHALL BE LOCATED A MIN OF 6' ABOVE GRADE FOR NON-DOMESTIC INST & 18" MIN ABOVE GRADE FOR DOMESTIC INST. DO NOT LOCATE NEAR ANY BUILDING OPENING, WINDOW, DOOR ETC. PLACE MARKER WORDED "GAS VENT" AT EACH VENT. VENT TO BE RAIN RESISTANT WITH APPROVED SCREEN.
- WHERE PRESS. OF MORE THAN 3 PSI IS FURNISHED THE CUSTOMER MUST OBTAIN SPECIAL PERMISSION FROM THE COMMISSIONER. (NYC ADMIN. CODE - GAS PIPING). PIPING OVER 1/2 PSI SHALL ALSO CONFORM TO ANSI CODES B31.2 - 1968.





NOTE: FOR VENT PIPING IN EXCESS OF 100' CONTACT SYSTEM DESIGN SECTION FOR CORRECT PIPE SIZE.

* VENT PIPE SIZE TABLE	
TOTAL LEN.	NOMINAL SIZE
0 - 50'	1-1/2"
0 - 100'	2"

THIS DRAWING CONFORMS TO:	
1	PUBLIC SERVICE COMM., CODES, RULES & REGULATIONS TRANS. & DIST. OF GAS SAFETY - 16NYCRR PART 255 & 261
2	N.Y.C. ADMINISTRATION CODE TITLE 27 & RS-16 SECT. P115. REVISION: UPDATED USING NEW SAP ITEMS'D

**nationalgrid**  
NYC

**M & R DRAWING FOR FISHER CS-803  
FLANGED REGULATOR - OUTSIDE SET  
15 PSIG INLET - UP TO 9,080 CFH**

DATE: 11/15/2012	EFFECTIVE DATE: 09/15/2013
DESIGN: PAT O NEIL	STD. DWG. NO. <b>CS-MET008</b>
DRAWN: PAT O NEIL	



BILL OF MATERIAL

NO.	ITEM	SIZE	QUAN.	BY	STOCK NO.
<b>CAPACITY UP TO 4,990 CFH</b>					
1A	REGULATOR, FISHER CS803IT-LIN W/INTEGRAL TRUE-MONITER TM600 MODULE, SHROUD (BLUE) #GE29773X032, 5/8" ORIFICE, F-F FLANGED MAIN SP. (BROWN) #GE49043X012, SP. RANGE 5.5" - 8.5" W.C., SET AT 6" W.C MONITOR SP. (GREEN) #GE30196X012, SP. RANGE 18" - 30" W.C., SET AT 21" W.C.	2"	1	NATIONALGRID	9386780
<b>CAPACITY 4,991 TO 9,080 CFH</b>					
1B	REGULATOR, FISHER CS803IT-LIN W/INTEGRAL TRUE-MONITER TM600 MODULE, SHROUD (BLUE) #GE29773X032, 7/8" ORIFICE, F-F FLANGED MAIN SP. (BROWN) #GE49043X012, SP. RANGE 5.5" - 8.5" W.C., SET AT 6" W.C MONITOR SP. (GREEN) #GE30196X012, SP. RANGE 18" - 30" W.C., SET AT 21" W.C.	2"	1	NATIONALGRID	9386793
2	VENT ASSEMBLY, WITH RAIN AND INSECT RESISTANT SCREEN	1"	2	CUSTOMER	9358640
3	COMPRESSION COUPLING, DRESSER STYLE 90 (FOR CORRECT COUPLING SIZE COMPRESSION COUPLING, DRESSER STYLE 38 SEE PIPE SIZE TABLE BELOW) COMPRESSION COUPLING, DRESSER STYLE 38	2"	1	CUSTOMER	9341517
		3"	1		9385252
		4"	1		9341622
4	INSUL. KIT FOR 150# ANSI F-F STEEL FLANGE	2"	1	CUSTOMER	9340992
5	STRAINER, MUESSCO "Y" OR EQ.	2"	1	CUSTOMER	9340158
6	VALVE, LOCKWING, MUELLER TAMP-R-LOK H11119B LOCK CLOSED OR EQ.	1-1/4"	1	CUSTOMER	-----
7	FLANGE, 150# ANSI F-F STEEL, WELD NECK OR SCREWED	2"	2	CUSTOMER	-----
8	FORGED STEEL CONCENTRIC REDUCER OR SCREWED FITTING (TO BE DETERMINED BY PIPE SIZE TABLE BELOW - SEE NOTE 11)	----	1	CUSTOMER	-----
9	FORGED STEEL CONCENTRIC REDUCER OR SCREWED FITTING (SEE NOTE 12)	----	1	CUSTOMER	-----
10	CONCRETE PAD FOR METER, 4" THICK, 5' WIDE, LENGTH DETERMINED BY LENGTH OF THE METER AND REGULATOR RUN	----	1	CUSTOMER	-----

RECOMMENDATED PIPE SIZE AT OUTLET OF REGUALTOR	
CAPACITY IN CFH	PIPE SIZE
UP TO 3,000	2"
3,001 - 5,000	3"
5,001 - 9,080	4"

**NOTES**

- PILOT GAS FROM FIRM LOAD METER - IF REQUIRED.
- PROVIDE ADEQUATE SPACING AROUND METER (FROM SURROUNDING PIPING & PARTITIONS) TO PERMIT REMOVAL & MAINTENANCE. PROVIDE 5 FT CLEAR SPACE IN FRONT OF METER.
- COAT PIPE & NON-GALVANIZED FITTINGS WITH RUSTOLEUM #7715. TWO COATS REQUIRED, BRUSH APPLIED.
- DO NOT WELD WITH METER IN LINE - USE SPOOL PIECE.
- ALL THREDOLETS TO BE INSTALLED ON STRAIGHT PIPE, NOT ON FITTINGS. A SCREWED REDUCING TEE MAY BE USED AS AN ALTERNATIVE TO A THREDOLET.
- VERTICAL PIPE SUPPORTS SHALL BE ADEQUATELY SEALED FROM WATER INFILTRATION & PROPERLY COATED TO RESIST CORROSION.
- SIZE OF REDUCER (ITEM 8), IF REQUIRED, TO BE DETERMINED BY DISTRIBUTION (HOUSE) PIPING DESIGN OF CUSTOMER'S CONTRACTOR.
- IF METERING INSTALLATION IS IN CLOSE PROXIMITY TO VEHICULAR TRAFFIC, INSTALL DEADMEN OUTSIDE FENCED METER AREA.
- A FULLY ENCLOSED (INCLUDING TOP) CHAIN LINK FENCE (CYCLONE) MIN. 8 FT. HIGH WITH GATE & LOCK IS REQUIRED ON ALL OUTSIDE SETS. TO BE SUPPLIED BY CUST.
- TEMPERATURE COMPENSATED METERS ARE TO BE INSTALLED IN ALL OUTDOOR LOCATIONS OR WHERE THE METER IS EXPOSED TO TEMPERATURES EQUIVALENT TO AN OUTDOOR ENVIRONMENT.
- FORGED STEEL CONCENTRIC REDUCER OR SCREWED FITTING (ITEM 8), IF REQUIRED, TO BE INSTALLED DIRECTLY AT THE OUTLET OF THE REGULATOR.
- SIZE OF REDUCER (ITEM 9), IF REQUIRED, TO BE DETERMINED BY DISTRIBUTION (HOUSE) PIPING DESIGN OF CUSTOMER'S CONTRACTOR.

**SPECIAL NOTE:** METER INSTALLATION AT ALL TIMES SHALL BE CLEAN, DRY, FREE FROM STEAM, CHEMICAL FUMES & A MINIMUM OF 3 FT. FROM SOURCES OF IGNITION, SUCH AS ELECTRIC RELAYS, SWITCHES, MOTOR STARTERS INCLUDING OIL OR GAS FIRED FURNACES & WATER HEATERS. INSTALLATIONS SHALL CONFORM TO NEW YORK STATE PSC CODE TITLE 16 PART 255 & 261 AND NEW YORK CITY BUILDING CODE TITLE 27 & RS-16 SECT. P115.

**ALL INSTALLATIONS**

- ALL PIPING SHALL CONFORM TO & BE TESTED ACCORDING TO THE NEW YORK CITY ADMIN. CODE, & NATIONALGRID SPECIFICATIONS.
- NO CAST IRON FITTINGS SHALL BE USED EXCEPT VALVES, REGULATORS, METERS, RELIEF VAL., AUTOMATIC SHUT-OFF VAL. & STRAINERS.
- DIAPHRAGMS OF ALL REGULATORS AND SAFETY DEVICES TO BE PROTECTED DURING PRESSURE TESTS.
- DO NOT USE BUSHINGS EXCEPT AS NOTED.
- REGULATOR TO BE INSTALLED WITH "FLOW ARROW" ON BODY AS SHOWN ON DRAWING.
- MISC. PIPE, FIT., BOLTS, NUTS, GASKETS, ANCHORAGE ASSEMBLIES, ETC., NOT LISTED TO BE FURNISHED & INST. BY CUSTOMER'S PLUMBER.
- ALL FACTORY THREADED FITTINGS ETC., TO BE THOROUGHLY CLEANED OF ALL FOREIGN MATERIAL BEFORE BEING INSTALLED.
- ALL PIPING TO HAVE NECESSARY SUPPORTS AND BRACES TO NON-METALLIC STRUCTURES & TO BE ELECTRICALLY INSULATED. SCHEMATIC DOES NOT EXHIBIT ALL PIPELINE SUPPORT NEEDS. INSTALL ADDITIONAL SUPPORTS & BRACES AS REQUIRED.
- NATIONALGRID SHALL NOT BE RESPONSIBLE FOR FITTING DIMENSIONS OR FOR SCALED DIMENSIONS.
- PREVENT ELECTRICAL SHORT BETWEEN GAS SERVICE ENTRANCE AND METER OUTLET.
- ALL VENT HEADS SHALL BE LOCATED A MIN OF 6' ABOVE GRADE FOR NON-DOMESTIC INST & 18" MIN ABOVE GRADE FOR DOMESTIC INST. DO NOT LOCATE NEAR ANY BUILDING OPENING, WINDOW, DOOR ETC. PLACE MARKER WORDED "GAS VENT" AT EACH VENT. VENT TO BE RAIN RESISTANT WITH APPROVED SCREEN.
- WHERE PRESS. OF MORE THAN 3 PSI IS FURNISHED THE CUSTOMER MUST OBTAIN SPECIAL PERMISSION FROM THE COMMISSIONER. (NYC ADMIN. CODE - GAS PIPING). PIPING OVER 1/2 PSI SHALL ALSO CONFORM TO ANSI CODES B31.2 - 1968.

FOR DETAILS SEE  
MTRS-6220 (CS-40)

\* VENT LINE

IF MULTIPLE METERS  
INST. 1/2" PURGE POINT  
W/ S&M LOCK PLUG  
(SEE NOTE 7)

TO METER(S)  
SEE NOTE 4  
(OUTLET OF METER PIPING  
TO BE ELECTRICALLY INSULATED  
FROM DISTRIBUTION PIPING)

NATIONALGRID WORK  
ENDS HERE

2" SERVICE VALVE  
(IF OVER 7 FT  
FROM FLOOR, VAL  
TO BE CHAIN  
OPERATED)

2" H.P. PLAS SERV  
(60 PSIG)

2" SERVICE VALVE

NATIONALGRID WORK  
ENDS HERE

2" H.P. PLAS SERV  
(60 PSIG)

2'  
MAX

2'  
MAX

4 LINEAR  
FT MAX TO  
SERV VALVE

\*\*  
18" MIN

\*\*  
5 PIPE DIA

LOCK CLOSED

SCHEMATIC

\* SEE VENT TABLE FOR SIZE

\*\* STRAIGHT PIPE REQUIRED

NOTES & BILL OF MATERIAL ON REVERSE SIDE

NOTE: FOR VENT PIPING IN EXCESS OF 100' CONTACT  
SYSTEM DESIGN SECTION FOR CORRECT PIPE SIZE.

**nationalgrid**

NYC

**M & R DRAWING FOR FISHER CS-803  
THREADED REGULATOR - INSIDE SET  
60 PSIG INLET - UP TO 19,090 CFH**

DATE: 11/15/2012

EFFECTIVE DATE: 09/15/2013

DESIGN: PAT O NEIL

STD. DWG.

DRAWN: PAT O NEIL

NO. **CS-MET009**

* VENT PIPE SIZE TABLE	
TOTAL LEN.	NOMINAL SIZE
0 - 50'	1-1/2"
0 - 100'	2"

THIS DRAWING CONFORMS TO:	
1	PUBLIC SERVICE COMM., CODES, RULES & REGULATIONS TRANS., & DIST. OF GAS SAFETY - 16NYCRR PART 255 & 261
2	N.Y.C. ADMINISTRATION CODE TITLE 27 & RS-16 SECT. P115.
	REVISION 1: LIN BROWN SPRINGS CAN BE USED UP TO 60 PSIG
	REVISION 2: UPDATED USING SAP ITEM ID'S

BILL OF MATERIAL

NO.	ITEM	SIZE	QUAN.	BY	STOCK NO.
<b>CAPACITY UP TO 14,550 CFH</b>					
1A	REGULATOR, FISHER CS803IT W/INTEGRAL TRUE-MONITER TM600 MODULE, 2 INCH THREADED NOTE THREADED MODEL COMES WITH DARK GREY SHROUD #GE29773X082, 5/8" ORIFICE GE29705X012 MONITOR SP. (GREEN) #GE30196X012, SP. RANGE 18" - 30" W.C., SET AT 21" W.C. MAIN SP. (BROWN) #GE49043X012, SP. RANGE 5.5" - 8.5" W.C., SET AT 6" W.C	2"	1	NATIONALGRID	9386778
<b>CAPACITY 14,551 TO 19,090 CFH</b>					
1B	REGULATOR, FISHER CS803IT W/INTEGRAL TRUE-MONITER TM600 MODULE, 2 INCH THREADED NOTE THREADED MODEL COMES WITH DARK GREY SHROUD #GE29773X082, 3/4" ORIFICE GE29706X012 MONITOR SP. (GREEN) #GE30196X012, SP. RANGE 18" - 30" W.C., SET AT 21" W.C. MAIN SP. (BROWN) #GE49043X012, SP. RANGE 5.5" - 8.5" W.C., SET AT 6" W.C	2"	1	NATIONALGRID	9386778 9386784 3/4" ORIFICE
2	VENT ASSEMBLY, WITH RAIN AND INSECT RESISTANT SCREEN (FOR CORRECT VENT ASSEMBLY SIZE SEE VENT & RELIEF TABLE ON FRONT SIDE)	1-1/2" 2"	1	CUSTOMER	9358641 9358636
3	COMPRESSION COUPLING, DRESSER STYLE 90, INSULATING (FOR VENT PIPING IN EXCESS OF 100' CONTACT SYSTEM DESIGN SECT. FOR CORRECT COUPLING SIZE)	1-1/2" 2"	1	CUSTOMER	9341465 9341468
4	COMPRESSION COUPLING, DRESSER STYLE 90, LOCK TYPE COMPRESSION COUPLING, DRESSER STYLE 38 (FOR CORRECT COUPLING SIZE COMPRESSION COUPLING, DRESSER STYLE 38 SEE PIPE SIZE TABLE BELOW)	2" 3" 4"	1 1 1	CUSTOMER	9341473 9385252 9341622
5	INSUL. KIT FOR 150# ANSI F-F STEEL FLANGE	2"	1	CUSTOMER	9340992
6	STRAINER, MUESSCO "Y" (REQUIRED FOR ROTARY METERS ONLY) OR EQ.	2"	1	CUSTOMER	9340158
7	VALVE, LOCKWING, MUELLER TAMP-R-LOK H11119B LOCK CLOSED OR EQ.	1-1/4"	1	CUSTOMER	----
8	FLANGE, 150# ANSI F-F STEEL, WELD NECK OR SCREWED	2"	2	CUSTOMER	----
9	FORGED STEEL CONCENTRIC REDUCER OR SCREWED FITTING (TO BE DETERMINED BY PIPE SIZE TABLE BELOW - SEE NOTE 8)	----	1	CUSTOMER	----
10	FORGED STEEL CONCENTRIC REDUCER OR SCREWED FITTING (SEE NOTE 9)	----	1	CUSTOMER	----

RECOMMENDATED PIPE SIZE AT OUTLET OF REGUALTOR	
CAPACITY IN CFH	PIPE SIZE
UP TO 3,000	2"
3,001 - 5,000	3"
5,001 - 19,090	4"

**NOTES**

- PILOT GAS FROM FIRM LOAD METER - IF REQUIRED.
- PROVIDE ADEQUATE SPACING AROUND METER (FROM SURROUNDING PIPING & PARTITIONS) TO PERMIT REMOVAL & MAINTENANCE. PROVIDE 5 FT CLEAR SPACE IN FRONT OF METER.
- ALL CLOSE/ALL THREADED NIPPLES, IF USED MUST BE EX-HEAVY, ALL VENT PIPING & FITTINGS TO BE STANDARD WALL THICKNESS.
- TEMPERATURE COMPENSATED METERS ARE TO BE INSTALLED IN ALL OUTDOOR LOCATIONS OR WHERE THE METER IS EXPOSED TO TEMPERATURES EQUIVALENT TO AN OUTDOOR ENVIRONMENT.
- ALL FLANGES TO BE SUPPLIED BY CUSTOMER. FLANGES TO BE STEEL & COMPATIBLE IN TYPE & PRESS. RATING WITH MATING FLANGE. FLANGES SHALL BE WELD NECK OR THREADED END AS SPECIFIED IN BILL OF MATERIALS; SLIP-ON FLANGES ARE NOT PERMITTED. WHERE MATERIAL IS NOT SPECIFIED, WELD NECK FLANGES SHALL BE USED UNLESS PIPE DIA. & PRESS. CONDITIONS PERMIT THE INSTALLATION OF SCREWED FITTINGS.
- DO NOT WELD WITH METER IN LINE USE SPOOL PIECE.
- ALL THREDOLETS TO BE INSTALLED ON STRAIGHT PIPE, NOT ON FITTINGS. A SCREWED REDUCING TEE MAY BE USED AS AN ALTERNATIVE TO A THREDOLET.
- FORGED STEEL CONCENTRIC REDUCER OR SCREWED FITTING (ITEM 9), IF REQUIRED, TO BE INSTALLED DIRECTLY AT THE OUTLET OF THE REGULATOR.
- SIZE OF REDUCER (ITEM 10), IF REQUIRED, TO BE DETERMINED BY DISTRIBUTION (HOUSE) PIPING DESIGN OF CUSTOMER'S CONTRACTOR.

**SPECIAL NOTE:** METER INSTALLATION AT ALL TIMES SHALL BE CLEAN, DRY, FREE FROM STEAM, CHEMICAL FUMES & A MINIMUM OF 3 FT. FROM SOURCES OF IGNITION, SUCH AS ELECTRIC RELAYS, SWITCHES, MOTOR STARTERS INCLUDING OIL OR GAS FIRED FURNACES & WATER HEATERS. INSTALLATIONS SHALL CONFORM TO NEW YORK STATE PSC CODE TITLE 16 PART 255 & 261 AND NEW YORK CITY BUILDING CODE TITLE 27 & RS-16 SECT. P115.

**ALL INSTALLATIONS**

- ALL PIPING SHALL CONFORM TO & BE TESTED ACCORDING TO THE NEW YORK CITY ADMIN. CODE, & NATIONALGRID SPECIFICATIONS.
- NO CAST IRON FITTINGS SHALL BE USED EXCEPT VALVES, REGULATORS, METERS, RELIEF VAL., AUTOMATIC SHUT-OFF VAL. & STRAINERS.
- DIAPHRAGMS OF ALL REGULATORS AND SAFETY DEVICES TO BE PROTECTED DURING PRESSURE TESTS.
- DO NOT USE BUSHINGS EXCEPT AS NOTED.
- REGULATOR TO BE INSTALLED WITH "FLOW ARROW" ON BODY AS SHOWN ON DRAWING.
- MISC. PIPE, FIT., BOLTS, NUTS, GASKETS, ANCHORAGE ASSEMBLIES, ETC., NOT LISTED TO BE FURNISHED & INST. BY CUSTOMER'S PLUMBER.
- ALL FACTORY THREADED FITTINGS ETC., TO BE THOROUGHLY CLEANED OF ALL FOREIGN MATERIAL BEFORE BEING INSTALLED.
- ALL PIPING TO HAVE NECESSARY SUPPORTS AND BRACES TO NON-METALLIC STRUCTURES & TO BE ELECTRICALLY INSULATED. SCHEMATIC DOES NOT EXHIBIT ALL PIPELINE SUPPORT NEEDS. INSTALL ADDITIONAL SUPPORTS & BRACES AS REQUIRED.
- NATIONALGRID SHALL NOT BE RESPONSIBLE FOR FITTING DIMENSIONS OR FOR SCALED DIMENSIONS.
- PREVENT ELECTRICAL SHORT BETWEEN GAS SERVICE ENTRANCE AND METER OUTLET.
- ALL VENT HEADS SHALL BE LOCATED A MIN OF 6' ABOVE GRADE FOR NON-DOMESTIC INST & 18" MIN ABOVE GRADE FOR DOMESTIC INST. DO NOT LOCATE NEAR ANY BUILDING OPENING, WINDOW, DOOR ETC. PLACE MARKER WORDED "GAS VENT" AT EACH VENT. VENT TO BE RAIN RESISTANT WITH APPROVED SCREEN.
- WHERE PRESS. OF MORE THAN 3 PSI IS FURNISHED THE CUSTOMER MUST OBTAIN SPECIAL PERMISSION FROM THE COMMISSIONER. (NYC ADMIN. CODE - GAS PIPING). PIPING OVER 1/2 PSI SHALL ALSO CONFORM TO ANSI CODES B31.2 - 1968.

FOR DETAILS SEE  
STD DWG MTRS-6220 (CS-40)

\* VENT LINE

IF MULTIPLE METERS  
INST. 1/2" PURGE POINT  
W/ S&M LOCK PLUG  
(SEE NOTE 7)

TO METER(S)  
SEE NOTE 4  
(OUTLET OF METER PIPING  
TO BE ELECTRICALLY INSULATED  
FROM DISTRIBUTION PIPING)

NATIONALGRID WORK  
ENDS HERE

2" SERVICE VALVE  
(IF OVER 7 FT  
FROM FLOOR, VAL  
TO BE CHAIN  
OPERATED)

2" H.P. PLAS SERV  
(60 PSIG)

2" SERVICE VALVE

NATIONALGRID WORK  
ENDS HERE

2" H.P. PLAS SERV  
(60 PSIG)

NOTES & BILL OF MATERIAL ON REVERSE SIDE

NOTE: FOR VENT PIPING IN EXCESS OF 100' CONTACT  
SYSTEM DESIGN SECTION FOR CORRECT PIPE SIZE.

SCHEMATIC

\* SEE VENT TABLE FOR SIZE  
\*\* STRAIGHT PIPE REQUIRED

**nationalgrid**

NYC

**M & R DRAWING FOR FISHER CS-803 FLANGED  
REGULATOR - INSIDE SET  
60 PSIG INLET - UP TO 19,090 CFH**

DATE: 11/15/2012

EFFECTIVE DATE: 09/15/2013

DESIGN: PAT O NEIL

STD. DWG.

DRAWN: PAT O NEIL

NO. **CS-MET010**

* VENT PIPE SIZE TABLE	
TOTAL LEN.	NOMINAL SIZE
0 - 50'	1-1/2"
0 - 100'	2"

THIS DRAWING CONFORMS TO:	
1	PUBLIC SERVICE COMM., CODES, RULES & REGULATIONS TRANS., & DIST. OF GAS SAFETY - 16NYCRR PART 255 & 261
2	N.Y.C. ADMINISTRATION CODE TITLE 27 & RS-16 SECT. P115.
REVISION 1: BLOWN LIN SPRING IS GOOD UP TO 60 PSIG	
REVISION 2: UPDATED USING SAP ITEM ID'S	

BILL OF MATERIAL

NO.	ITEM	SIZE	QUAN.	BY	STOCK NO.
<b>CAPACITY UP TO 14,550 CFH</b>					
1A	REGULATOR, FISHER CS803IT W/INTEGRAL TRUE-MONITER TM600 MODULE, SHROUD (BLUE) #GE29773X032, 5/8" ORIFICE GE29705X012, F-F FLANGED MAIN SP. (BROWN LIN) #GE49043X012, SP. RANGE 5.5"-8.5" W.C., SET @ 6" WC MONITOR SP. (GREEN) #GE30196X012, SP. RANGE 18" - 30" W.C., SET AT 21" W.C.	2"	1	NATIONALGRID	9386780
<b>CAPACITY 14,551 TO 19,090 CFH</b>					
1B	REGULATOR, FISHER CS803IT W/INTEGRAL TRUE-MONITER TM600 MODULE, SHROUD (BLUE) #GE29773X032, 3/4" ORIFICE GE29706X012, F-F FLANGED MAIN SP. (BROWN LIN) #GE49043X012, SP. RANGE 5.5"-8.5" W.C., SET @ 6" WC MONITOR SP. (GREEN) #GE30196X012, SP. RANGE 18" - 30" W.C., SET AT 21" W.C.	2"	1	NATIONALGRID	9386780 9386784 3/4" ORIFICE
2	VENT ASSEMBLY, WITH RAIN AND INSECT RESISTANT SCREEN (FOR CORRECT VENT ASSEMBLY SIZE SEE VENT & RELIEF TABLE ON FRONT SIDE)	1-1/2" 2"	1	CUSTOMER	9358641 9358636
3	COMPRESSION COUPLING, DRESSER STYLE 90, INSULATING (FOR VENT PIPING IN EXCESS OF 100' CONTACT SYSTEM DESIGN SECT. FOR CORRECT COUPLING SIZE)	1-1/2" 2"	1	CUSTOMER	9341465 9341468
4	COMPRESSION COUPLING, DRESSER STYLE 90, LOCK TYPE COMPRESSION COUPLING, DRESSER STYLE 38 (FOR CORRECT COUPLING SIZE COMPRESSION COUPLING, DRESSER STYLE 38 SEE PIPE SIZE TABLE BELOW)	2" 3" 4"	1 1 1	CUSTOMER	9341473 9385252 9341622
5	INSUL. KIT FOR 150# ANSI F-F STEEL FLANGE	2"	1	CUSTOMER	9340992
6	STRAINER, MUESSCO "Y" (REQUIRED FOR ROTARY METERS ONLY) OR EQ.	2"	1	CUSTOMER	9340158
7	VALVE, LOCKWING, MUELLER TAMP-R-LOK H11119B LOCK CLOSED OR EQ.	1-1/4"	1	CUSTOMER	----
8	FLANGE, 150# ANSI F-F STEEL, WELD NECK OR SCREWED	2"	2	CUSTOMER	----
9	FORGED STEEL CONCENTRIC REDUCER OR SCREWED FITTING (TO BE DETERMINED BY PIPE SIZE TABLE BELOW - SEE NOTE 8)	----	1	CUSTOMER	----
10	FORGED STEEL CONCENTRIC REDUCER OR SCREWED FITTING (SEE NOTE 9)	----	1	CUSTOMER	----

RECOMMENDATED PIPE SIZE AT OUTLET OF REGULATOR	
CAPACITY IN CFH	PIPE SIZE
UP TO 3,000	2"
3,001 - 5,000	3"
5,001 - 19,090	4"

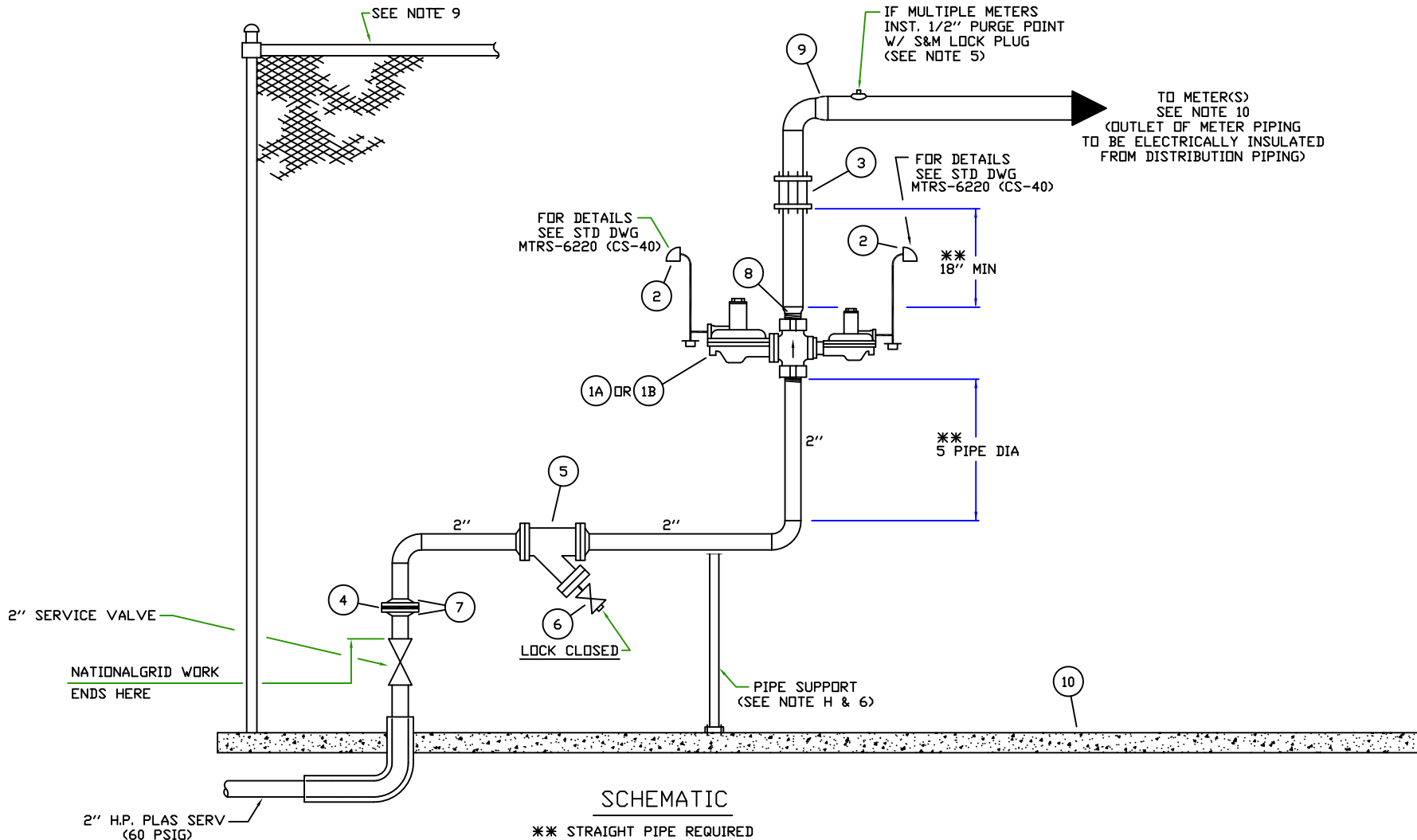
**NOTES**

- PILOT GAS FROM FIRM LOAD METER - IF REQUIRED.
- PROVIDE ADEQUATE SPACING AROUND METER (FROM SURROUNDING PIPING & PARTITIONS) TO PERMIT REMOVAL & MAINTENANCE. PROVIDE 5 FT CLEAR SPACE IN FRONT OF METER.
- ALL CLOSE/ALL THREADED NIPPLES, IF USED MUST BE EX-HEAVY, ALL VENT PIPING & FITTINGS TO BE STANDARD WALL THICKNESS.
- TEMPERATURE COMPENSATED METERS ARE TO BE INSTALLED IN ALL OUTDOOR LOCATIONS OR WHERE THE METER IS EXPOSED TO TEMPERATURES EQUIVALENT TO AN OUTDOOR ENVIRONMENT.
- ALL FLANGES TO BE SUPPLIED BY CUSTOMER. FLANGES TO BE STEEL & COMPATIBLE IN TYPE & PRESS. RATING WITH MATING FLANGE. FLANGES SHALL BE WELD NECK OR THREADED END AS SPECIFIED IN BILL OF MATERIALS; SLIP-ON FLANGES ARE NOT PERMITTED. WHERE MATERIAL IS NOT SPECIFIED, WELD NECK FLANGES SHALL BE USED UNLESS PIPE DIA. & PRESS. CONDITIONS PERMIT THE INSTALLATION OF SCREWED FITTINGS.
- DO NOT WELD WITH METER IN LINE USE SPOOL PIECE.
- ALL THREDOLETS TO BE INSTALLED ON STRAIGHT PIPE, NOT ON FITTINGS. A SCREWED REDUCING TEE MAY BE USED AS AN ALTERNATIVE TO A THREDOLET.
- FORGED STEEL CONCENTRIC REDUCER OR SCREWED FITTING (ITEM 9), IF REQUIRED, TO BE INSTALLED DIRECTLY AT THE OUTLET OF THE REGULATOR.
- SIZE OF REDUCER (ITEM 10), IF REQUIRED, TO BE DETERMINED BY DISTRIBUTION (HOUSE) PIPING DESIGN OF CUSTOMER'S CONTRACTOR.

**SPECIAL NOTE:** METER INSTALLATION AT ALL TIMES SHALL BE CLEAN, DRY, FREE FROM STEAM, CHEMICAL FUMES & A MINIMUM OF 3 FT. FROM SOURCES OF IGNITION, SUCH AS ELECTRIC RELAYS, SWITCHES, MOTOR STARTERS INCLUDING OIL OR GAS FIRED FURNACES & WATER HEATERS. INSTALLATIONS SHALL CONFORM TO NEW YORK STATE PSC CODE TITLE 16 PART 255 & 261 AND NEW YORK CITY BUILDING CODE TITLE 27 & RS-16 SECT. P115.

**ALL INSTALLATIONS**

- ALL PIPING SHALL CONFORM TO & BE TESTED ACCORDING TO THE NEW YORK CITY ADMIN. CODE, & NATIONALGRID SPECIFICATIONS.
- NO CAST IRON FITTINGS SHALL BE USED EXCEPT VALVES, REGULATORS, METERS, RELIEF VAL., AUTOMATIC SHUT-OFF VAL. & STRAINERS.
- DIAPHRAGMS OF ALL REGULATORS AND SAFETY DEVICES TO BE PROTECTED DURING PRESSURE TESTS.
- DO NOT USE BUSHINGS EXCEPT AS NOTED.
- REGULATOR TO BE INSTALLED WITH "FLOW ARROW" ON BODY AS SHOWN ON DRAWING.
- MISC. PIPE, FIT., BOLTS, NUTS, GASKETS, ANCHORAGE ASSEMBLIES, ETC., NOT LISTED TO BE FURNISHED & INST. BY CUSTOMER'S PLUMBER.
- ALL FACTORY THREADED FITTINGS ETC., TO BE THOROUGHLY CLEANED OF ALL FOREIGN MATERIAL BEFORE BEING INSTALLED.
- ALL PIPING TO HAVE NECESSARY SUPPORTS AND BRACES TO NON-METALLIC STRUCTURES & TO BE ELECTRICALLY INSULATED. SCHEMATIC DOES NOT EXHIBIT ALL PIPELINE SUPPORT NEEDS. INSTALL ADDITIONAL SUPPORTS & BRACES AS REQUIRED.
- NATIONALGRID SHALL NOT BE RESPONSIBLE FOR FITTING DIMENSIONS OR FOR SCALED DIMENSIONS.
- PREVENT ELECTRICAL SHORT BETWEEN GAS SERVICE ENTRANCE AND METER OUTLET.
- ALL VENT HEADS SHALL BE LOCATED A MIN OF 6' ABOVE GRADE FOR NON-DOMESTIC INST & 18" MIN ABOVE GRADE FOR DOMESTIC INST. DO NOT LOCATE NEAR ANY BUILDING OPENING, WINDOW, DOOR ETC. PLACE MARKER WORDED "GAS VENT" AT EACH VENT. VENT TO BE RAIN RESISTANT WITH APPROVED SCREEN.
- WHERE PRESS. OF MORE THAN 3 PSI IS FURNISHED THE CUSTOMER MUST OBTAIN SPECIAL PERMISSION FROM THE COMMISSIONER. (NYC ADMIN. CODE - GAS PIPING). PIPING OVER 1/2 PSI SHALL ALSO CONFORM TO ANSI CODES B31.2 - 1968.



NOTES & BILL OF MATERIAL ON REVERSE SIDE

NOTE: FOR VENT PIPING IN EXCESS OF 100' CONTACT SYSTEM DESIGN SECTION FOR CORRECT PIPE SIZE.

* VENT PIPE SIZE TABLE	
TOTAL LEN.	NOMINAL SIZE
0 - 50'	1-1/2"
0 - 100'	2"

THIS DRAWING CONFORMS TO:	
1	PUBLIC SERVICE COMM., CODES, RULES & REGULATIONS
	TRANS., & DIST. OF GAS SAFETY - 16NYCRR PART 255 & 261
2	N.Y.C. ADMINISTRATION CODE TITLE 27 & RS-16 SECT. P115.
	REVISION 1: BROWN LIN SPRING IS ACCEPTABLE UP TO 60 PSIG INLETS
	REVISION 2: REVISED USING SAP ITEM ID'S

**nationalgrid**  
NYC

**M & R DRAWING FOR FISHER CS-803  
THREADED REGULATOR - OUTSIDE SET  
60 PSIG INLET - UP TO 19,090 FH**

DATE: 11/15/2012	EFFECTIVE DATE: 09/15/2013
DESIGN: PAT O NEIL	STD. DWG. NO. <b>CS-MET011</b>
DRAWN: PAT O NEIL	



BILL OF MATERIAL

NO.	ITEM	SIZE	QUAN.	BY	STOCK NO.
<b>CAPACITY UP TO 14,550 CFH</b>					
1A	REGULATOR, FISHER CS803IT W/INTEGRAL TRUE-MONITER TM600 MODULE, SHROUD (DARK GRAY) #GE29773X082, 5/8" ORIFICE GE29705X012, SCREWED MAIN SP. (BROWN LIN) #GE49043X012, SP. RANGE 5.5"-8.5" W.C., SET @ 6" W.C MONITOR SP. (GREEN) #GE30196X012, SP. RANGE 18" - 30" W.C., SET AT 21" W.C. NOTE: THREADED CS803 COMES WITH DARK GRAY SHROUD	2"	1	NATIONALGRID	9386778
<b>CAPACITY 14,551 TO 19,090 CFH</b>					
1B	REGULATOR, FISHER CS803IT W/INTEGRAL TRUE-MONITER TM600 MODULE, SHROUD (DARK GRAY) #GE29773X082, 3/4" ORIFICE GE29706X012, SCREWED MAIN SP. (BROWN LIN) #GE49043X012, SP. RANGE 5.5"-8.5" W.C., SET @ 6" W.C MONITOR SP. (GREEN) #GE30196X012, SP. RANGE 18" - 30" W.C., SET AT 21" W.C. NOTE: THREADED CS803 COMES WITH DARK GRAY SHROUD	2"	1	NATIONALGRID	9386778 9386784 3/4" ORIFICE
2	VENT ASSEMBLY, WITH RAIN AND INSECT RESISTANT SCREEN	1"	2	CUSTOMER	9358640
3	COMPRESSION COUPLING, DRESSER STYLE 90, LOCK TYPE	2"	1	CUSTOMER	9341473
	COMPRESSION COUPLING, DRESSER STYLE 38 (FOR CORRECT COUPLING SIZE	3"	1		9385252
	COMPRESSION COUPLING, DRESSER STYLE 38 SEE PIPE SIZE TABLE BELOW)	4"	1		9341622
4	INSUL. KIT FOR 150# ANSI F-F STEEL FLANGE	2"	1	CUSTOMER	9340992
5	STRAINER, MUESSCO "Y" OR EQ.	2"	1	CUSTOMER	9340158
6	VALVE, LOCKWING, MUELLER TAMP-R-LOK H11119B LOCK CLOSED OR EQ.	1-1/4"	1	CUSTOMER	-----
7	FLANGE, 150# ANSI F-F STEEL, WELD NECK OR SCREWED	2"	2	CUSTOMER	-----
8	FORGED STEEL CONCENTRIC REDUCER OR SCREWED FITTING (TO BE DETERMINED BY PIPE SIZE TABLE BELOW - SEE NOTE 11)	----	1	CUSTOMER	-----
9	FORGED STEEL CONCENTRIC REDUCER OR SCREWED FITTING (SEE NOTE 12)	----	1	CUSTOMER	-----
10	CONCRETE PAD FOR METER, 4" THICK, 5' WIDE, LENGTH DETERMINED BY LENGTH OF THE METER AND REGULATOR RUN	----	1	CUSTOMER	-----

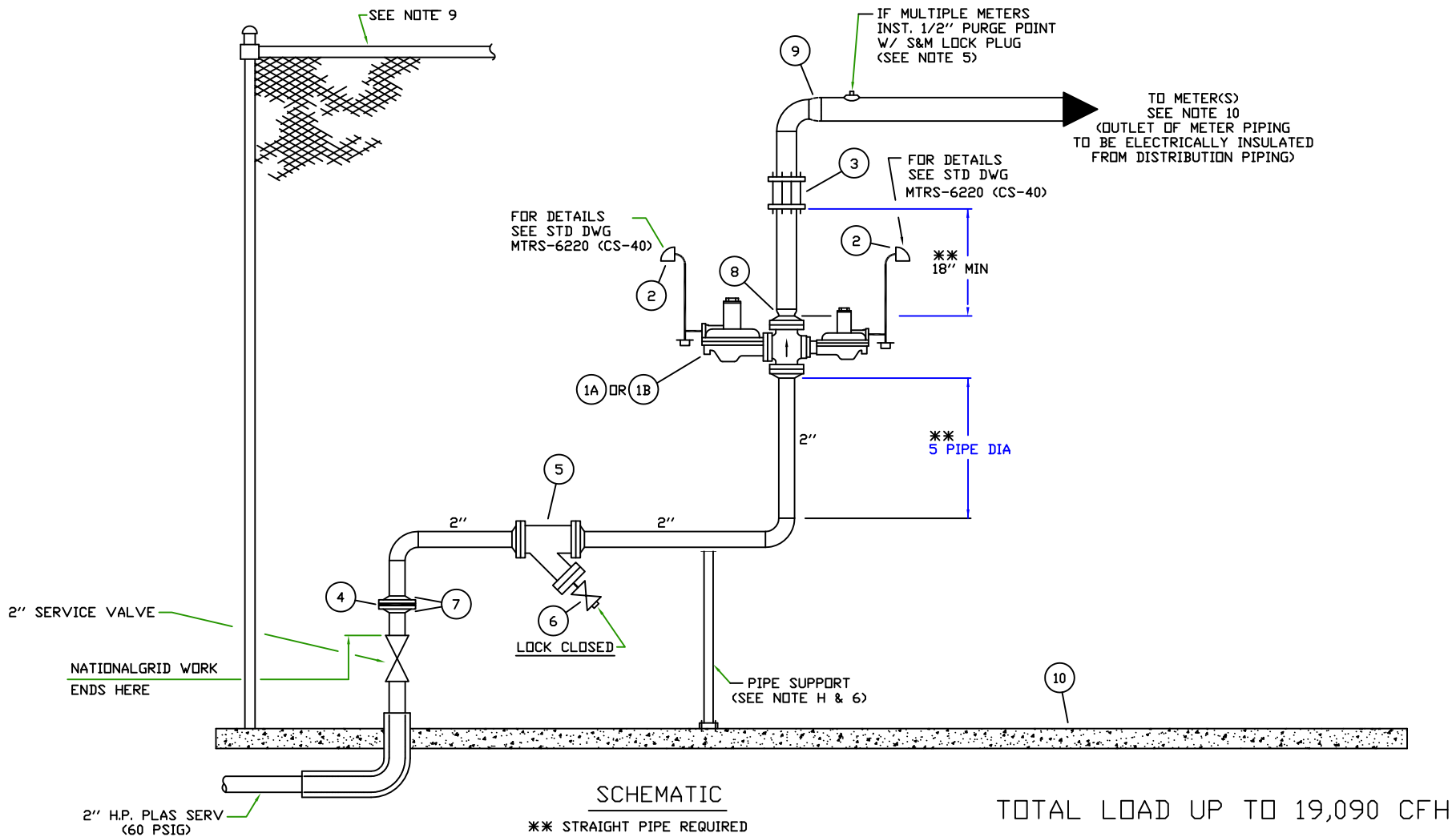
RECOMMENDED PIPE SIZE AT OUTLET OF REGUALTOR	
CAPACITY IN CFH	PIPE SIZE
UP TO 3,000	2"
3,001 - 5,000	3"
5,001 - 19,090	4"

- NOTES**
- PILOT GAS FROM FIRM LOAD METER - IF REQUIRED.
  - PROVIDE ADEQUATE SPACING AROUND METER (FROM SURROUNDING PIPING & PARTITIONS) TO PERMIT REMOVAL & MAINTENANCE. PROVIDE 5 FT CLEAR SPACE IN FRONT OF METER.
  - COAT PIPE & NON-GALVANIZED FITTINGS WITH RUSTOLEUM #7715. TWO COATS REQUIRED, BRUSH APPLIED.
  - DO NOT WELD WITH METER IN LINE - USE SPOOL PIECE.
  - ALL THREDOLETS TO BE INSTALLED ON STRAIGHT PIPE, NOT ON FITTINGS. A SCREWED REDUCING TEE MAY BE USED AS AN ALTERNATIVE TO A THREDOLET.
  - VERTICAL PIPE SUPPORTS SHALL BE ADEQUATELY SEALED FROM WATER INFILTRATION & PROPERLY COATED TO RESIST CORROSION.
  - SIZE OF REDUCER (ITEM 8), IF REQUIRED, TO BE DETERMINED BY DISTRIBUTION (HOUSE) PIPING DESIGN OF CUSTOMER'S CONTRACTOR.
  - IF METERING INSTALLATION IS IN CLOSE PROXIMITY TO VEHICULAR TRAFFIC, INSTALL DEADMEN OUTSIDE FENCED METER AREA.
  - A FULLY ENCLOSED (INCLUDING TOP) CHAIN LINK FENCE (CYCLONE) MIN. 8 FT. HIGH WITH GATE & LOCK IS REQUIRED ON ALL OUTSIDE SETS. TO BE SUPPLIED BY CUST.
  - TEMPERATURE COMPENSATED METERS ARE TO BE INSTALLED IN ALL OUTDOOR LOCATIONS OR WHERE THE METER IS EXPOSED TO TEMPERATURES EQUIVALENT TO AN OUTDOOR ENVIRONMENT.
  - FORGED STEEL CONCENTRIC REDUCER OR SCREWED FITTING (ITEM 8), IF REQUIRED, TO BE INSTALLED DIRECTLY AT THE OUTLET OF THE REGULATOR.
  - SIZE OF REDUCER (ITEM 9), IF REQUIRED, TO BE DETERMINED BY DISTRIBUTION (HOUSE) PIPING DESIGN OF CUSTOMER'S CONTRACTOR.

**SPECIAL NOTE:** METER INSTALLATION AT ALL TIMES SHALL BE CLEAN, DRY, FREE FROM STEAM, CHEMICAL FUMES & A MINIMUM OF 3 FT. FROM SOURCES OF IGNITION, SUCH AS ELECTRIC RELAYS, SWITCHES, MOTOR STARTERS INCLUDING OIL OR GAS FIRED FURNACES & WATER HEATERS. INSTALLATIONS SHALL CONFORM TO NEW YORK STATE PSC CODE TITLE 16 PART 255 & 261 AND NEW YORK CITY BUILDING CODE TITLE 27 & RS-16 SECT. P115.

**ALL INSTALLATIONS**

- ALL PIPING SHALL CONFORM TO & BE TESTED ACCORDING TO THE NEW YORK CITY ADMIN. CODE, & NATIONALGRID SPECIFICATIONS.
- NO CAST IRON FITTINGS SHALL BE USED EXCEPT VALVES, REGULATORS, METERS, RELIEF VAL., AUTOMATIC SHUT-OFF VAL. & STRAINERS.
- DIAPHRAGMS OF ALL REGULATORS AND SAFETY DEVICES TO BE PROTECTED DURING PRESSURE TESTS.
- DO NOT USE BUSHINGS EXCEPT AS NOTED.
- REGULATOR TO BE INSTALLED WITH "FLOW ARROW" ON BODY AS SHOWN ON DRAWING.
- MISC. PIPE, FIT., BOLTS, NUTS, GASKETS, ANCHORAGE ASSEMBLIES, ETC., NOT LISTED TO BE FURNISHED & INST. BY CUSTOMER'S PLUMBER.
- ALL FACTORY THREADED FITTINGS ETC., TO BE THOROUGHLY CLEANED OF ALL FOREIGN MATERIAL BEFORE BEING INSTALLED.
- ALL PIPING TO HAVE NECESSARY SUPPORTS AND BRACES TO NON-METALLIC STRUCTURES & TO BE ELECTRICALLY INSULATED. SCHEMATIC DOES NOT EXHIBIT ALL PIPELINE SUPPORT NEEDS. INSTALL ADDITIONAL SUPPORTS & BRACES AS REQUIRED.
- NATIONALGRID SHALL NOT BE RESPONSIBLE FOR FITTING DIMENSIONS OR FOR SCALED DIMENSIONS.
- PREVENT ELECTRICAL SHORT BETWEEN GAS SERVICE ENTRANCE AND METER OUTLET.
- ALL VENT HEADS SHALL BE LOCATED A MIN OF 6' ABOVE GRADE FOR NON-DOMESTIC INST & 18" MIN ABOVE GRADE FOR DOMESTIC INST. DO NOT LOCATE NEAR ANY BUILDING OPENING, WINDOW, DOOR ETC. PLACE MARKER WORDED "GAS VENT" AT EACH VENT. VENT TO BE RAIN RESISTANT WITH APPROVED SCREEN.
- WHERE PRESS. OF MORE THAN 3 PSI IS FURNISHED THE CUSTOMER MUST OBTAIN SPECIAL PERMISSION FROM THE COMMISSIONER. (NYC ADMIN. CODE - GAS PIPING). PIPING OVER 1/2 PSI SHALL ALSO CONFORM TO ANSI CODES B31.2 - 1968.



NOTE: FOR VENT PIPING IN EXCESS OF 100' CONTACT SYSTEM DESIGN SECTION FOR CORRECT PIPE SIZE.

**nationalgrid**  
NYC

**M & R DRAWING FOR FISHER CS-803  
FLANGED REGULATOR - OUTSIDE SET  
60 PSIG INLET - UP TO 19,090 CFH**

DATE: 11/15/2012	EFFECTIVE DATE: 09/15/2013
DESIGN: PAT O NEIL	STD. DWG.
DRAWN: PAT O NEIL	NO. <b>CS-MET012</b>

* VENT PIPE SIZE TABLE	
TOTAL LEN.	NOMINAL SIZE
0 - 50'	1-1/2"
0 - 100'	2"

THIS DRAWING CONFORMS TO:	
1	PUBLIC SERVICE COMM., CODES, RULES & REGULATIONS
	TRANS., & DIST. OF GAS SAFETY - 16NYCRR PART 255 & 261
2	N.Y.C. ADMINISTRATION CODE TITLE 27 & RS-16 SECT. P115.
	REVISION 1: BROWN SPRING IS NOW ACCEPTABLE UP TO 60 PSIG
	REVISION 2: UPDATED USING SAP ITEM ID'S



**BILL OF MATERIAL**

NO.	ITEM	SIZE	QUAN.	BY	STOCK NO.
<b>CAPACITY UP TO 14,550 CFH</b>					
1A	REGULATOR, FISHER CS803IT W/INTEGRAL TRUE-MONITER TM600 MODULE, SHROUD (BLUE) #GE29773X032, 5/8" ORIFICE GE29705X012, F-F FLANGED MAIN SP. (BROWN) #GE49043X012, SP. RANGE 5.5" - 8.5" W.C., SET AT 6" W.C MONITOR SP. (GREEN) #GE30196X012, SP. RANGE 18" - 30" W.C., SET AT 21" W.C.	2"	1	NATIONALGRID	9386780
<b>CAPACITY 14,551 TO 19,090 CFH</b>					
1B	REGULATOR, FISHER CS803IT W/INTEGRAL TRUE-MONITER TM600 MODULE, SHROUD (BLUE) #GE29773X032, 3/4" ORIFICE GE29706X012, F-F FLANGED MAIN SP. (BROWN) #GE49043X012, SP. RANGE 5.5" - 8.5" W.C., SET AT 6" W.C MONITOR SP. (GREEN) #GE30196X012, SP. RANGE 18" - 30" W.C., SET AT 21" W.C.	2"	1	NATIONALGRID	9386780 9386784 3/4" ORIFICE
2	VENT ASSEMBLY, WITH RAIN AND INSECT RESISTANT SCREEN	1"	2	CUSTOMER	9358640
3	COMPRESSION COUPLING, DRESSER STYLE 90, LOCK TYPE	2"	1	CUSTOMER	9341473
	COMPRESSION COUPLING, DRESSER STYLE 38 (FOR CORRECT COUPLING SIZE)	3"	1		9385252
4	COMPRESSION COUPLING, DRESSER STYLE 38	4"	1	CUSTOMER	9341622
	COMPRESSION COUPLING, DRESSER STYLE 38 SEE PIPE SIZE TABLE BELOW)	2"	1		9340992
5	INSUL. KIT FOR 150# ANSI F-F STEEL FLANGE	2"	1	CUSTOMER	9340158
6	STRAINER, MUESSCO "Y" OR EQ.	2"	1	CUSTOMER	-----
7	VALVE, LOCKWING, MUELLER TAMP-R-LOK H11119B LOCK CLOSED OR EQ.	1-1/4"	1	CUSTOMER	-----
8	FLANGE, 150# ANSI F-F STEEL, WELD NECK OR SCREWED	2"	2	CUSTOMER	-----
9	FORGED STEEL CONCENTRIC REDUCER OR SCREWED FITTING (TO BE DETERMINED BY PIPE SIZE TABLE BELOW - SEE NOTE 11)	----	1	CUSTOMER	-----
10	FORGED STEEL CONCENTRIC REDUCER OR SCREWED FITTING (SEE NOTE 12)	----	1	CUSTOMER	-----
10	CONCRETE PAD FOR METER, 4" THICK, 5' WIDE, LENGTH DETERMINED BY LENGTH OF THE METER AND REGULATOR RUN	----	1	CUSTOMER	-----

RECOMMENDATED PIPE SIZE AT OUTLET OF REGULATOR	
CAPACITY IN CFH	PIPE SIZE
UP TO 3,000	2"
3,001 - 5,000	3"
5,001 - 19,090	4"

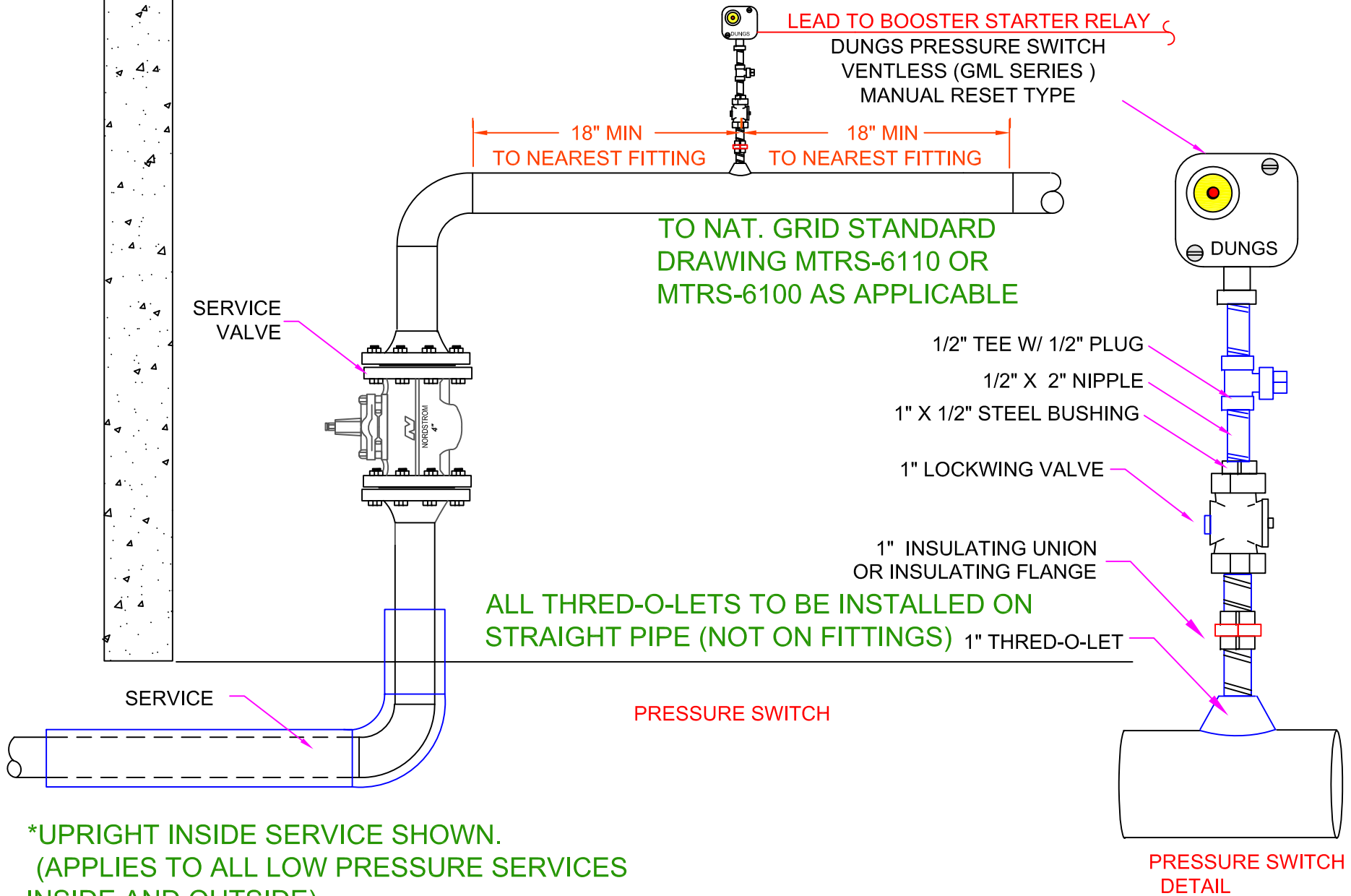
**NOTES**

1. PILOT GAS FROM FIRM LOAD METER - IF REQUIRED.
2. PROVIDE ADEQUATE SPACING AROUND METER (FROM SURROUNDING PIPING & PARTITIONS) TO PERMIT REMOVAL & MAINTENANCE. PROVIDE 5 FT CLEAR SPACE IN FRONT OF METER.
3. COAT PIPE & NON-GALVANIZED FITTINGS WITH RUSTOLEUM #7715. TWO COATS REQUIRED, BRUSH APPLIED.
4. DO NOT WELD WITH METER IN LINE - USE SPOOL PIECE.
5. ALL THREDOLETS TO BE INSTALLED ON STRAIGHT PIPE, NOT ON FITTINGS. A SCREWED REDUCING TEE MAY BE USED AS AN ALTERNATIVE TO A THREDOLET.
6. VERTICAL PIPE SUPPORTS SHALL BE ADEQUATELY SEALED FROM WATER INFILTRATION & PROPERLY COATED TO RESIST CORROSION.
7. SIZE OF REDUCER (ITEM 8), IF REQUIRED, TO BE DETERMINED BY DISTRIBUTION (HOUSE) PIPING DESIGN OF CUSTOMER'S CONTRACTOR.
8. IF METERING INSTALLATION IS IN CLOSE PROXIMITY TO VEHICULAR TRAFFIC, INSTALL DEADMEN OUTSIDE FENCED METER AREA.
9. A FULLY ENCLOSED (INCLUDING TOP) CHAIN LINK FENCE (CYCLONE) MIN. 8 FT. HIGH WITH GATE & LOCK IS REQUIRED ON ALL OUTSIDE SETS. TO BE SUPPLIED BY CUST.
10. TEMPERATURE COMPENSATED METERS ARE TO BE INSTALLED IN ALL OUTDOOR LOCATIONS OR WHERE THE METER IS EXPOSED TO TEMPERATURES EQUIVALENT TO AN OUTDOOR ENVIRONMENT.
11. FORGED STEEL CONCENTRIC REDUCER OR SCREWED FITTING (ITEM 8), IF REQUIRED, TO BE INSTALLED DIRECTLY AT THE OUTLET OF THE REGULATOR.
12. SIZE OF REDUCER (ITEM 9), IF REQUIRED, TO BE DETERMINED BY DISTRIBUTION (HOUSE) PIPING DESIGN OF CUSTOMER'S CONTRACTOR.


**SPECIAL NOTE:** METER INSTALLATION AT ALL TIMES SHALL BE CLEAN, DRY, FREE FROM STEAM, CHEMICAL FUMES & A MINIMUM OF 3 FT. FROM SOURCES OF IGNITION, SUCH AS ELECTRIC RELAYS, SWITCHES, MOTOR STARTERS INCLUDING OIL OR GAS FIRED FURNACES & WATER HEATERS. INSTALLATIONS SHALL CONFORM TO NEW YORK STATE PSC CODE TITLE 16 PART 255 & 261 AND NEW YORK CITY BUILDING CODE TITLE 27 & RS-16 SECT. P115.

**ALL INSTALLATIONS**

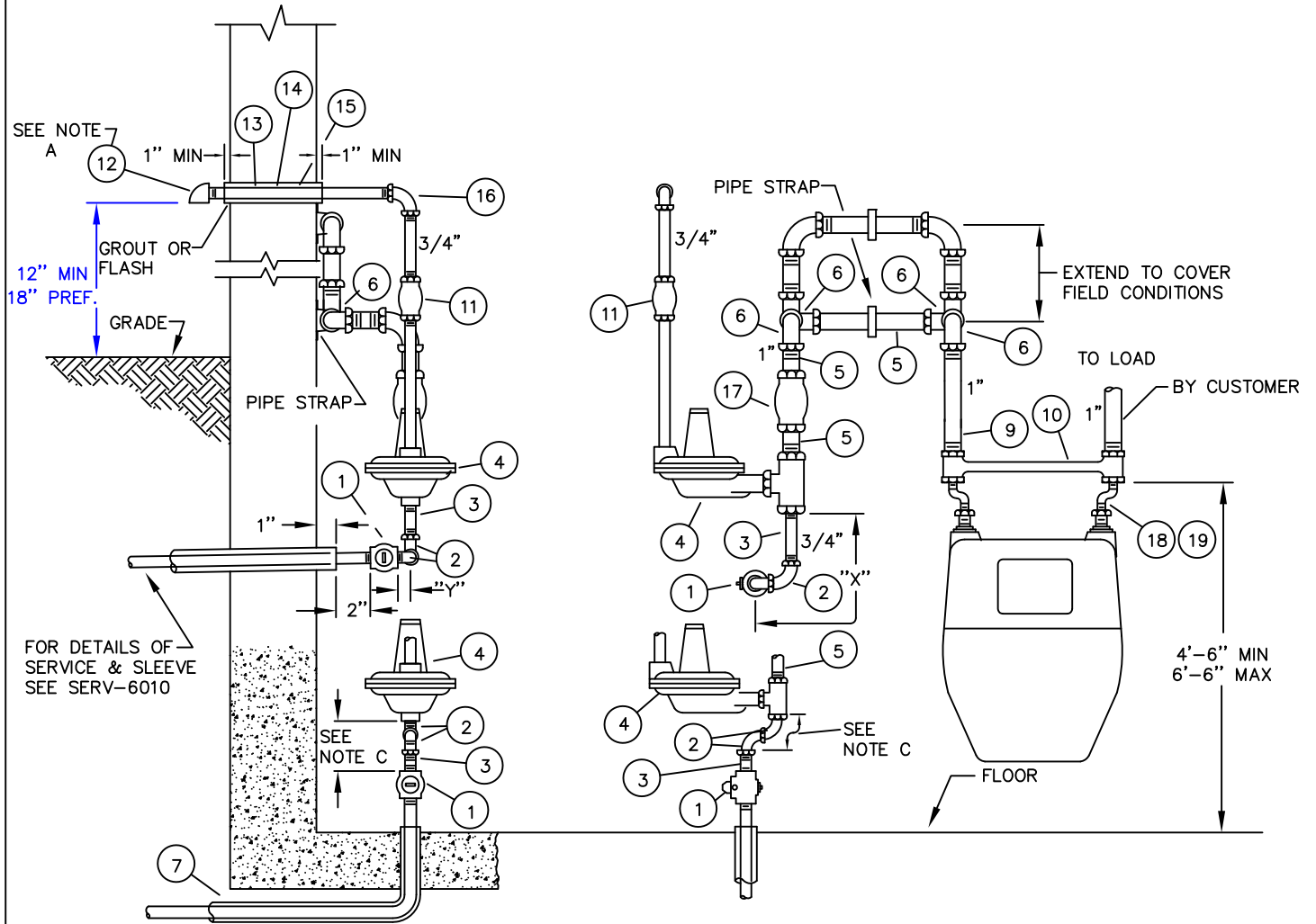
- A) ALL PIPING SHALL CONFORM TO & BE TESTED ACCORDING TO THE NEW YORK CITY ADMIN. CODE, & NATIONALGRID SPECIFICATIONS.
- B) NO CAST IRON FITTINGS SHALL BE USED EXCEPT VALVES, REGULATORS, METERS, RELIEF VAL., AUTOMATIC SHUT-OFF VAL. & STRAINERS.
- C) DIAPHRAGMS OF ALL REGULATORS AND SAFETY DEVICES TO BE PROTECTED DURING PRESSURE TESTS.
- D) DO NOT USE BUSHINGS EXCEPT AS NOTED.
- E) REGULATOR TO BE INSTALLED WITH "FLOW ARROW" ON BODY AS SHOWN ON DRAWING.
- F) MISC. PIPE, FIT., BOLTS, NUTS, GASKETS, ANCHORAGE ASSEMBLIES, ETC., NOT LISTED TO BE FURNISHED & INST. BY CUSTOMER'S PLUMBER.
- G) ALL FACTORY THREADED FITTINGS ETC., TO BE THOROUGHLY CLEANED OF ALL FOREIGN MATERIAL BEFORE BEING INSTALLED.
- H) ALL PIPING TO HAVE NECESSARY SUPPORTS AND BRACES TO NON-METALLIC STRUCTURES & TO BE ELECTRICALLY INSULATED. SCHEMATIC DOES NOT EXHIBIT ALL PIPELINE SUPPORT NEEDS. INSTALL ADDITIONAL SUPPORTS & BRACES AS REQUIRED.
- J) NATIONALGRID SHALL NOT BE RESPONSIBLE FOR FITTING DIMENSIONS OR FOR SCALED DIMENSIONS.
- K) PREVENT ELECTRICAL SHORT BETWEEN GAS SERVICE ENTRANCE AND METER OUTLET.
- L) ALL VENT HEADS SHALL BE LOCATED A MIN OF 6' ABOVE GRADE FOR NON-DOMESTIC INST & 18" MIN ABOVE GRADE FOR DOMESTIC INST. DO NOT LOCATE NEAR ANY BUILDING OPENING, WINDOW, DOOR ETC. PLACE MARKER WORDED "GAS VENT" AT EACH VENT. VENT TO BE RAIN RESISTANT WITH APPROVED SCREEN.
- M) WHERE PRESS. OF MORE THAN 3 PSI IS FURNISHED THE CUSTOMER MUST OBTAIN SPECIAL PERMISSION FROM THE COMMISSIONER. (NYC ADMIN. CODE - GAS PIPING). PIPING OVER 1/2 PSI SHALL ALSO CONFORM TO ANSI CODES B31.2 - 1968.



\*UPRIGHT INSIDE SERVICE SHOWN.  
(APPLIES TO ALL LOW PRESSURE SERVICES  
INSIDE AND OUTSIDE)

	<p>NYC</p>		<p><b>PRESSURE SWITCH DETAILS FOR BOOSTER INSTALLATIONS</b></p>	
	<p>REVISIONS: NEW DRAWING</p>	<p>DATE: 12/15/2014</p> <p>DESIGN: PAUL GUGLIOTTA</p> <p>DRAWN: PAUL GUGLIOTTA</p>	<p>EFFECTIVE DATE: 12/15/2014</p> <p>STD. DWG. NO.</p>	<p><b>CS-MET013</b></p>

**NOTE:**  
**DISTANCE FROM SERVICE VALVE TO REGULATOR MUST BE KEPT TO A MINIMUM (SEE NOTE C).**



**SIDE ELEVATION**

**FRONT ELEVATION**

**nationalgrid**

NEW YORK CITY

**TYPICAL DOMESTIC REGULATOR AND METER INSTALLATION - 60 LB SYSTEM (1 & 2 FAMILY DWELLINGS)**

**REVISIONS:** REVISED USING SAP ITEM ID #'S

DATE: 07/01/2003

EFFECTIVE DATE: 09/15/2013

DESIGN: E.G.C.

STD. DWG.

DRAWN: R.W.C. / P. DIMAIO

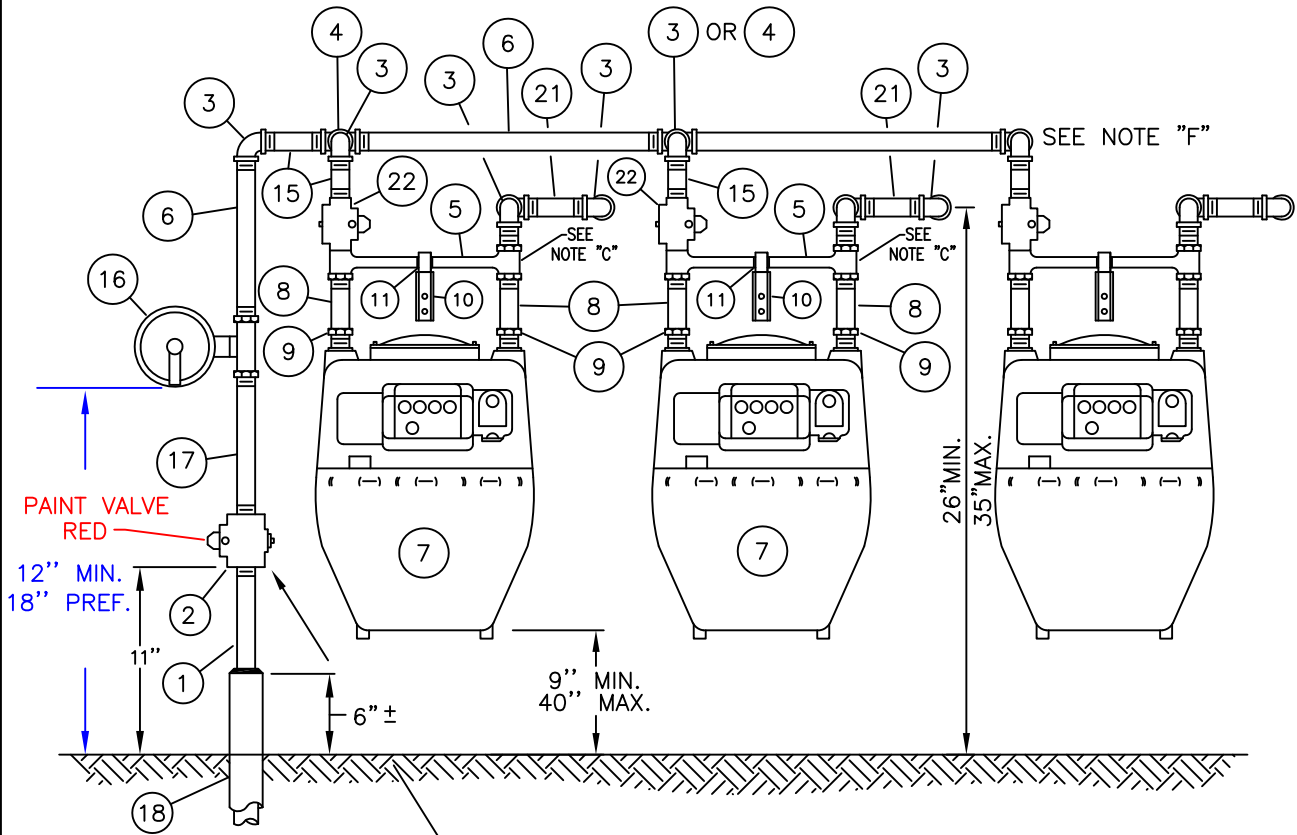
NO. **MTRS-6010**

**NOTES**

- A. IT IS PREFERRED THAT REGULATOR VENTS BE INSTALLED AT A HEIGHT 18 INCHES ABOVE GRADE, HOWEVER, THE MINIMUM ALLOWABLE VENT HEIGHT SHALL BE 12 INCHES ABOVE FINAL GRADE. IN CASES OF KNOWN FLOOD LOCATIONS, THE PREFERRED REGULATOR VENT HEIGHT ABOVE THE FLOOD HEIGHT IS 18" (12" MINIMUM). THE REGULATOR VENT SHALL BE 18" (WHERE PRACTICAL) FROM ANY OPENING WHICH COULD ALLOW VENTED GAS TO ENTER.
- B. IF CONDITIONS DO NOT PERMIT INSTALLATION ACCORDING TO THIS STANDARD DRAWING AND METER IS NOT LOCATED AS SPECIFIED. APPROVAL MUST BE REQUESTED FROM THE SECTION MANGER OR GAS ENGINEERING BEFORE INSTALLATION. METERS ARE TO BE LOCATED AS CLOSE AS POSSIBLE TO THE SERVICE ENTRANCE.
- C. IF LENGTHS "X" + "Y" ARE GREATER THAN 4'-0" AND DO NOT EXCEED 9'-0". A METER ROOM WITH A FOUR (4) HOUR FIRE RATING AND ADEQUATE VENTILATION IS REQUIRED (NYC BUILDING CODE). FOR GREATER THAN 9', CONTACT GAS ENGINEERING
- D. METER LOCATION MUST HAVE ADEQUATE VENTILATION AS PER NYC BUILDING CODE.
- E. METER LOCATION MUST BE CLEAN, DRY, FREE STEAM, CHEMICAL FUMES, AND A MINIMUM OF 3' FROM SOURCES OF IGNITION SUCH AS ELECTRIC RELAYS, SWITCHES, MOTOR STARTERS, INCLUDING OIL OR GAS FIRED FURNACES AND WATER HEATERS.
- F. A MINIMUM OF 5' CLEAR SPACE AROUND THE METER AND REGULATOR INSTALLATION MUST BE MAINTAINED.

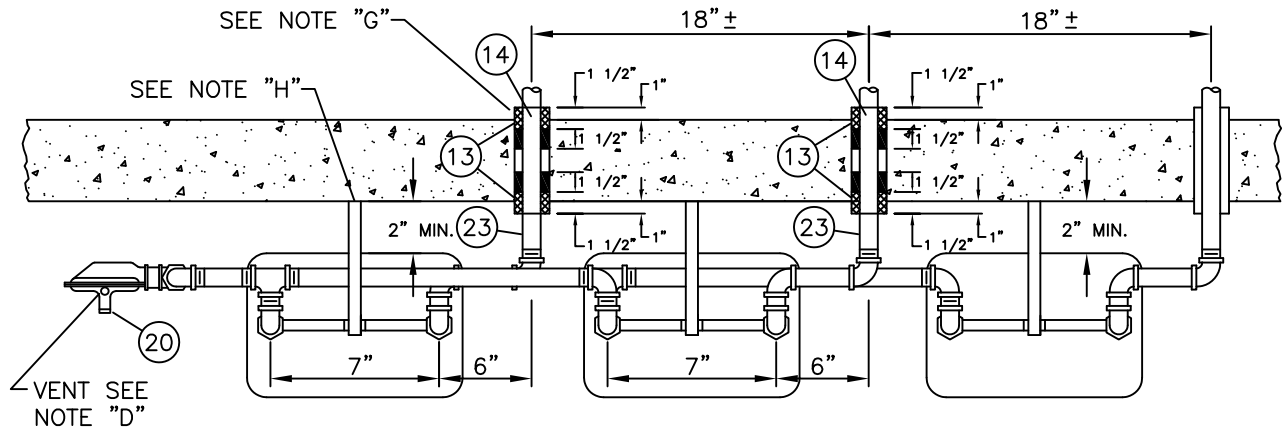
NOTE: ALL MATERIALS AFTER THE SERVICE VALVE WILL BE FURNISHED AND INSTALLED BY THE CUSTOMER EXCEPT FOR THE REGULATOR WHICH IS FURNISHED BY THE COMPANY AND INSTALLED BY THE CUSTOMER. THE METER WILL BE FURNISHED AND INSTALLED BY THE COMPANY.

19	METER CAPS/NUTS 20 LIGHT	9340787
18	METER SWIVALS,GALV,1" X 20 LIGHT	9383109
17	COMPRESSION COUPLING, 1" , DRESSER STYLE 90, INSULATING	9341467
16	ELBOW. 3/4" M.I.	9341308
15	PIPE SLEEVE	
14	YARN PACKING	9353980
13	FLEXIBLE SEALING COMPOUND (DUXSEAL)	9330862
12	VENT ASSEMBLY, 3/4" , W / RAIN AND INSECT RESISTANT SCREEN	9358637
11	COMPRESSION COUPLING, 3/4". DRESSER STYLE 90. INSULATING	9341469
10	METER BAR, 1" X 1" X 1" 6-1/ 2" CENTERS. INSUL BARREL OUTLET	9383181
9	SHOULDER NIPPLE 1" (IF CLOSE NIPPLE USED – EXTRA HEAVY)	SHOULDER NIPPLE CLOSE NIPPLE 9340776 9340752
8	ITEM DELETED	
7	90 SERVICE SLEEVE ELBOW UNIT (42-80-080)	NON STOCK
6	ELBOW, 1" M.I.	9341251
5	NIPPLE, 1"X 4" (MINIMUM)	9340780
4	REGULATOR, 3 /4" X 1" AMERICAN 1813 OR ITRON B31R / B42R – 4 OR EQUAL	9383047
3	NIPPLE. 3/4" X 6"	9341073
2	STREET ELBOW 3/4" M.I.	9341380
1	3/4" SERVICE VALVE TAMPER PROOF LOCK WING (LOCK CLOSED MODEL) OR EQUAL	9358325
<b>No.</b>	<b>ITEM</b>	<b>NATIONAL GRID CODE No.</b>
<b>BILL OF MATERIAL</b>		



CURB VALVE IS NOT REQUIRED PROVIDED THERE IS AN ACCESSIBLE OUTSIDE SHUTOFF

**ELEVATION**



**PLAN**

**nationalgrid**

NEW YORK CITY

**TYPICAL HIGH PRESSURE 60#  
MULTIPLE SET (SEE NOTE F)  
OUTSIDE INSTALLATION**

**REVISIONS:** REVISED USING SAP ITEM ID #'S

DATE: 07/01/2003

EFFECTIVE DATE: 09/15/2013

DESIGN: K. IOANNOU

STD. DWG.

DRAWN: P. DIMAIO

NO. **MTRS-6020**

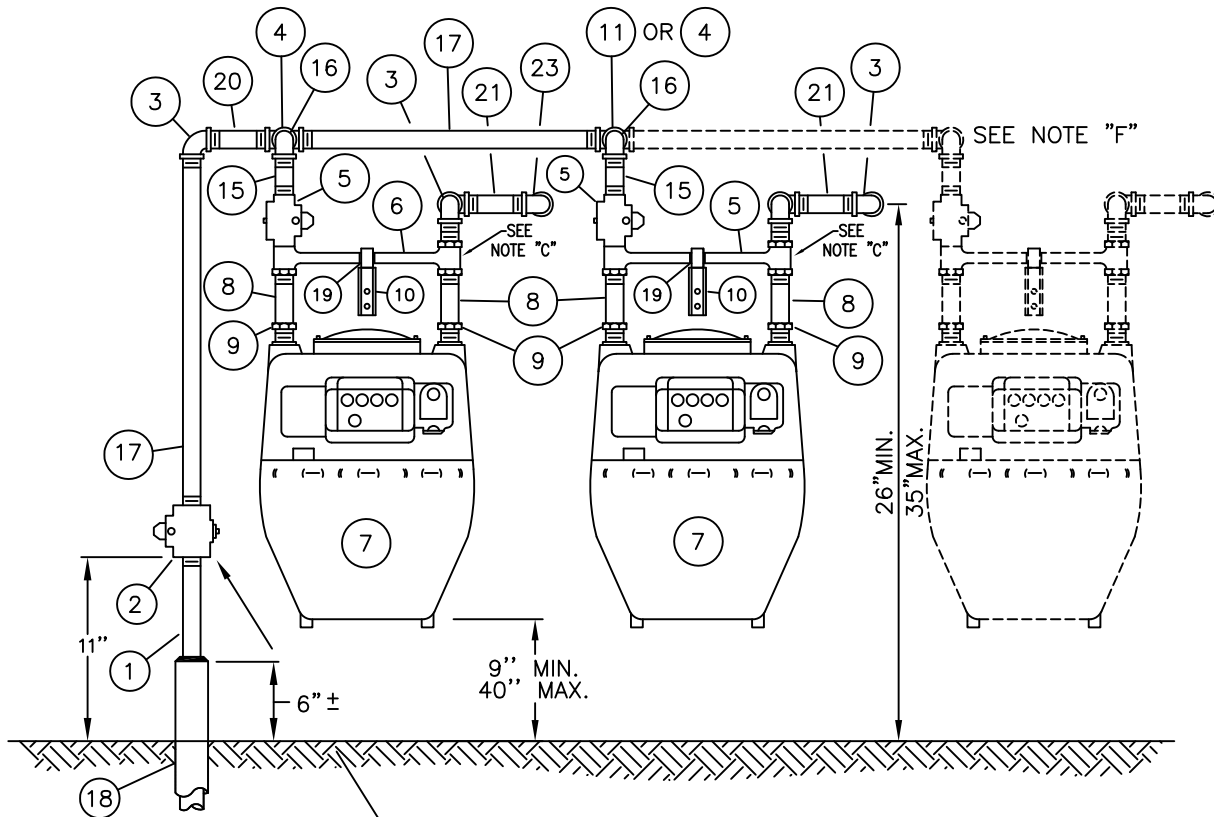
**NOTES**

- A. COAT PIPE AND NON-GALVANIZED FITTINGS WITH ROYSTON ROYLAC # 9421 (ITEM 20) ALUMINUM FINISH COAT OR EQUAL.
- B. WHERE APPLICABLE METER INSTALLATION SHOULD BE PROTECTED FROM VEHICULAR TRAFFIC.
- C. NATIONAL GRID'S WORK TO END AT METER BAR (INSTALL TEMPORARY PLUG AT METER BAR INLET). PIPING TO BUILDING BY OTHERS (F.S. TO RECYCLE PLUG).
- D. REGULATOR VENT TO FACE DOWN AND MUST BE EQUIPPED WITH RAIN AND INSECT RESISTANT SCREEN. **IT IS PREFERRED THAT REGULATOR VENTS BE INSTALLED AT A HEIGHT 18 INCHES ABOVE GRADE, HOWEVER, THE MINIMUM ALLOWABLE VENT HEIGHT SHALL BE 12 INCHES ABOVE FINAL GRADE. IN CASES OF KNOWN FLOOD LOCATIONS, THE PREFERRED REGULATOR VENT HEIGHT ABOVE THE FLOOD HEIGHT IS 18" (12" MINIMUM). THE REGULATOR VENT SHALL BE 18" (WHERE PRACTICAL) FROM ANY OPENING WHICH COULD ALLOW VENTED GAS TO ENTER.**
- E. IF CONDITIONS DO NOT PERMIT INSTALLATION ACCORDING TO THIS STANDARD DRAWING AND METER IS NOT LOCATED AS SPECIFIED, APPROVAL MUST BE REQUESTED FROM SECTION MANAGER OR GAS ENGINEERING BEFORE INSTALLATION. METERS ARE TO BE LOCATED AS POSSIBLE TO THE SERVICE ENTRANCE.
- F. MAXIMUM NUMBER OF METERS FOR THIS INSTALLATION SHOULD BE THREE (3) METERS. FOR GREATER THAN FOR GREATER THAN THREE (3) METERS CONSULT GAS ENGINEERING.
- G. WALL SLEEVE FOR PENETRATION THROUGH CONCRETE WALL. NOT REQUIRED FOR PENETRATION THROUGH STUCCO OR FRAME CONSTRUCTION.
- H. UPON COMPLETION OF HOUSE PIPING F.S. TO REMOVE AND RECYCLE METER BAR SUPPORTS. (ITEM 10)

**NOTE: ALL MATERIALS AFTER THE SERVICE VALVE WILL BE FURNISHED AND INSTALLED BY THE CUSTOMER EXCEPT FOR THE REGULATOR WHICH IS FURNISHED BY THE COMPANY AND INSTALLED BY THE CUSTOMER. THE METER WILL BE FURNISHED AND INSTALLED BY THE COMPANY.**

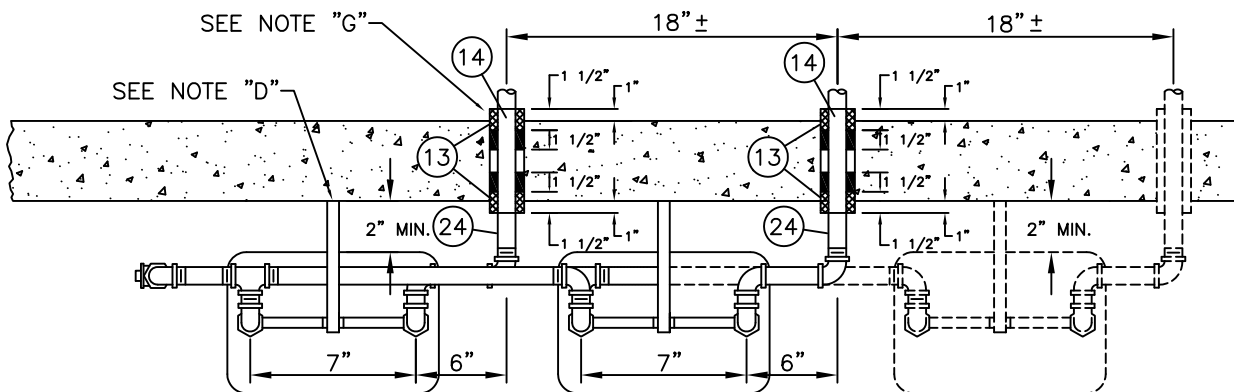
23	CUSTOMERS HOUSE LINE, 1" STEEL, GALVANIZED THROUGH WALL	---
22	COCK, 1" PILFER - PROOF, GAS ENERGY INC. PT – 60 OR EQUAL	9339611
21	NIPPLE, 1" X 4" GALVANIZED	9340641
20	WEATHER AND NATIONAL GRID PROOF VENT SCREEN (USE ONLY THIS TYPE)	9358640
19	ALUMINUM PAINT, ROYSTON ROYLAC #9421	9358199
18	3/4" SERVICE SLEEVE ELBOW UNIT (BENT SERVICE – SLEEVE UNIT ONLY)	9340887
17	NIPPLE, 3/4" GALVANIZED	9340633
16	REGULATOR, 3/4" X 1" (1/8" ORIFICE)	9383047
15	NIPPLE, 1" X 3" SHOULDER GALVANIZED	9340641
14	WALL SLEEVE, 1-1/4" STD. WT. STEEL PIPE (2" LONGER THAN WALL THICK.)	---
13	FLEXIBLE SEALING COMPOUND (DUXSEAL)	9330862
12	YARN, PACKING	9353980
11	NEOPRENE – 1/4" THICK, 8" WIDE	9358039
10	METER BAR SUPPORT, GALVANIZED 8-1/2"	9340885
9	NUT CONNECTION, 20 LT., (CAP), GALVANIZED	9340787
8	OFFSET SWIVEL, 1" 20 LT., GALVANIZED	9383109
7	METER, APPROVED HARD CASE (TEMPERATURE COMP.)	---
6	NIPPLE, 1" GALVANIZED	9340641
5	METER BAR, 1" X 1" X 1", INSULATED OUTLET	9383181
4	TEE , 1" GALVANIZED	9342066
3	ELBOW, 1" GALVANIZED	9341181
2	COCK, 3/4" PILFER-PROOF, GAS ENERGY INC. PT-60 OR EQUAL PAINTED RED	9358325
1	SERVICE, 3/4" STEEL PIPE	

No.	ITEM	NATIONAL GRID CODE No.
<b>BILL OF MATERIAL</b>		



CURB VALVE IS NOT REQUIRED PROVIDED THERE IS AN ACCESSIBLE OUTSIDE SHUTOFF

**ELEVATION**



**PLAN**

**nationalgrid**

NEW YORK CITY

**TYPICAL LOW PRESSURE  
MULTIPLE (3 METER MAX. SEE NOTE F) SET  
OUTSIDE INSTALLATION**

**REVISIONS:** UPDATED PAGE 2 TO NEW SAP ITEM ID'S

DATE: 07/01/2003

EFFECTIVE DATE: 09/15/2013

DESIGN: K. IOANNOU

STD. DWG.

DRAWN: P. DIMAIO

NO. **MTRS-6030**

**NOTES**

- A. COAT PIPE AND NON-GALVANIZED FITTINGS WITH ROYSTON ROYLAC #9421 (ITEM 22) ALUMINUM FINISH COAT OR EQUAL.
- B. WHERE APPLICABLE METER INSTALLATION SHOULD BE PROTECTED FROM VEHICULAR TRAFFIC.
- C. NATIONAL GRID COMPANY WORK TO END AT METER BAR (INSTALL TEMPORARY PLUG AT METER BAR INLET). PIPING TO BUILDING BY OTHERS (F.S. TO RECYCLE PLUG).
- D. UPON COMPLETION OF HOUSE PIPING F.S. TO REMOVE AND RECYCLE METER BAR SUPPORTS. (ITEM 10)
- E. IF CONDITIONS DO NOT PERMIT INSTALLATION ACCORDING TO THIS STANDARD DRAWING AND METER IS NOT LOCATED AS SPECIFIED, APPROVAL MUST BE REQUESTED FROM SECTION MANAGER. OR GAS ENGINEERING BEFORE INSTALLATION. METERS ARE TO BE LOCATED AS POSSIBLE TO THE SERVICE ENTRANCE.
- F. MAXIMUM NUMBER OF METERS FOR THIS INSTALLATION SHOULD BE THREE (3) METERS. FOR GREATER THAN FOR GREATER THAN THREE (3) METERS CONSULT GAS ENGINEERING.
- G. WALL SLEEVE FOR PENETRATION THROUGH CONCRETE WALL. NOT REQUIRED FOR PENETRATION THROUGH STUCCO OR FRAME CONSTRUCTION.

**NOTE: ALL MATERIALS AFTER THE SERVICE VALVE WILL BE FURNISHED AND INSTALLED BY THE CUSTOMER. THE METER WILL BE FURNISHED AND INSTALLED BY THE COMPANY.**

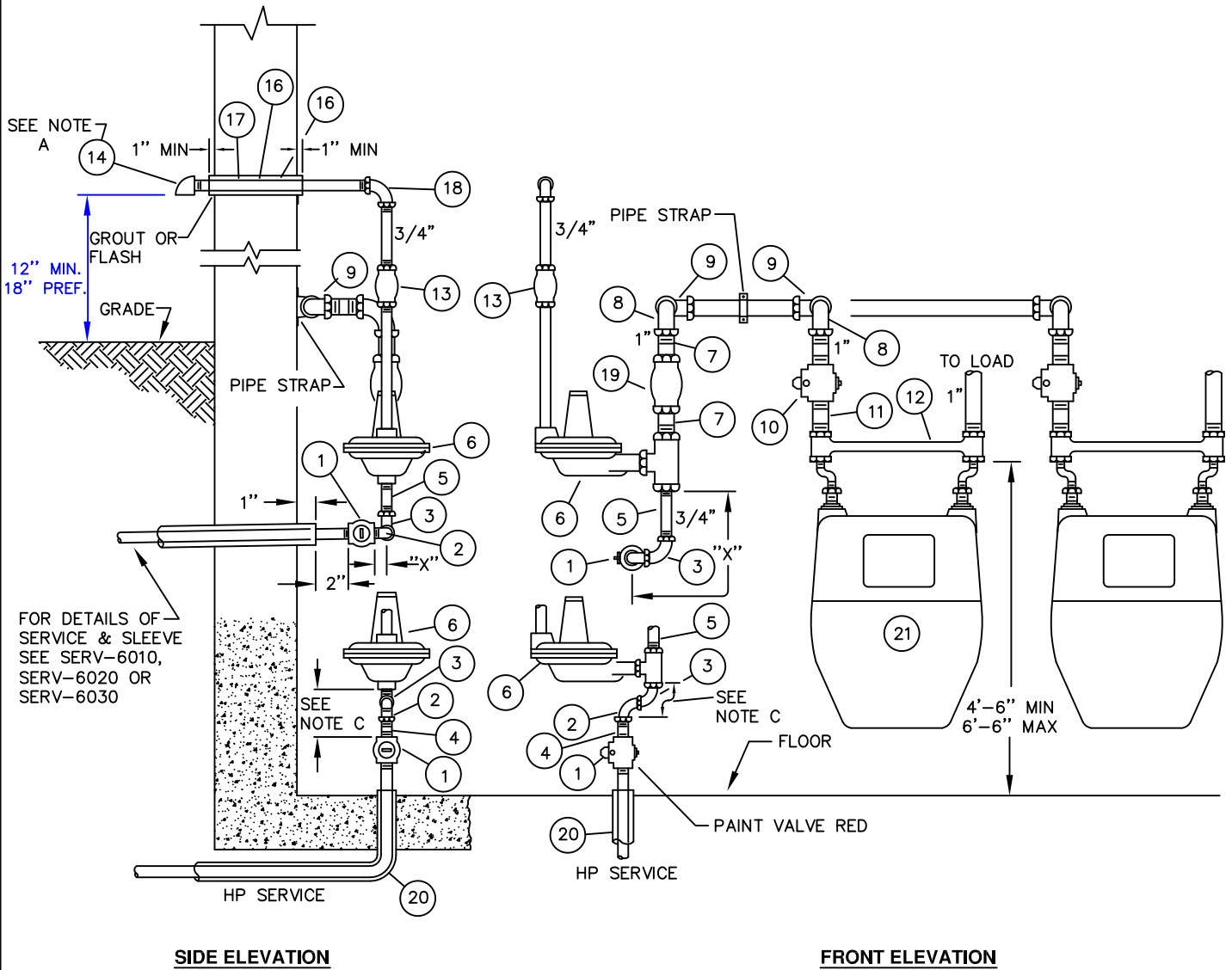
24	CUSTOMERS HOUSE LINE, 1" STEEL, GALVANIZED THROUGH WALL	
23	ELBOW, 1" 90 GALVANIZED	9341181
22	ALUMINUM PAINT, ROYSTON ROYLAC #9421	9358199
21	NIPPLE, 1" X 4" GALVANIZED	9340641
20	NIPPLE, 1-1/2" X 3" GALVANIZED	9340692
19	NEOPRENE - 1/4" THICK, 6" WIDE	NON STOCK
18	3/4" SERVICE SLEEVE ELBOW UNIT (BENT SERVICE - SLEEVE UNIT ONLY)	9340887
17	PIPE 1-1/2" STEEL PLAIN	9340937
16	ELBOW, 1" STREET GALVANIZED	9341192
15	NIPPLE, 1" X 3" SHOULDER GALVANIZED	9340641
14	WALL SLEEVE, 1-1/4" STD. WT. STEEL PIPE (2" LONGER THAN WALL THICK.)	9340935
13	FLEXIBLE SEALING COMPOUND (DUXSEAL)	9330862
12	YARN, PACKING	9353980
11	REDUCING ELBOW, 1-1/2" X 1" GALVANIZED	9341225
10	METER BAR SUPPORT, GALVANIZED 8 1/2"	NON STOCK
9	NUT CONNECTION, 20 LT., (CAP), GALVANIZED	9340787
8	OFFSET SWIVEL, 1" 20 LT., GALVANIZED	9383109
7	METER, APPROVED HARD CASE (AMERICAN 250 OR EQUAL) TEMP. COMP.	---
6	METER BAR, 1" X 1" X 1", WITH 1" INSULATED OUTLET GALVANIZED	9383181
5	COCK, 1" PILFER - PROOF, GAS ENERGY INC. PT - 60 OR EQUAL	9339700
4	TEE, 1- 1/2" X 1" GALVANIZED	9342036
3	ELBOW, 1 1/2" GALVANIZED	9341224
2	COCK, 1-1/2" PILFER - PROOF, GAS ENERGY INC. PT-60 OR EQUAL	9339661
1	SERVICE, 1-1/2" STEEL PIPE	


No.	ITEM	NATIONAL GRID CODE No.
-----	------	------------------------

**BILL OF MATERIAL**



**NOTE:**  
**DISTANCE FROM SERVICE VALVE TO REGULATOR MUST BE KEPT TO A MINIMUM (SEE NOTE C).**



 <p>NEW YORK CITY</p>	<b>TYPICAL DOMESTIC REGULATOR AND METER INSTALLATION - 15 LB SYSTEM          (1 &amp; 2 FAMILY DWELLINGS)</b> FOR 0-775 CFH FLOW	
	REVISIONS: REVISED USING SAP ITEM ID #'S	DATE: 07/01/2003 DESIGN: S.T. CATAPANO DRAWN: J. CASTALUCCI / P. DIMAIO

**NOTES**

- A. IT IS PREFERRED THAT REGULATOR VENTS BE INSTALLED AT A HEIGHT 18 INCHES ABOVE GRADE, HOWEVER, THE MINIMUM ALLOWABLE VENT HEIGHT SHALL BE 12 INCHES ABOVE FINAL GRADE. IN CASES OF KNOWN FLOOD LOCATIONS, THE PREFERRED REGULATOR VENT HEIGHT ABOVE THE FLOOD HEIGHT IS 18" (12" MINIMUM). THE REGULATOR VENT SHALL BE 18" (WHERE PRACTICAL) FROM ANY OPENING WHICH COULD ALLOW VENTED GAS TO ENTER.
- B. IF CONDITIONS DO NOT PERMIT INSTALLATION ACCORDING TO THIS STANDARD DRAWING AND METER IS NOT LOCATED AS SPECIFIED. APPROVAL MUST BE REQUESTED FROM THE SECTION MANGER OR ENGINEERING BEFORE INSTALLATION. METERS ARE TO BE LOCATED AS CLOSE AS POSSIBLE TO THE SERVICE ENTRANCE
- C. IF LENGTHS "X" + "Y" ARE GREATER THAN 4'-0" AND DO NOT EXCEED 9'-0". A METER ROOM WITH A FOUR (4) HOUR FIRE RATING AND ADEQUATE VENTILATION IS REQUIRED (N.Y.C. BUILDING CODE).
- D. METER LOCATION MUST BE CLEAN, DRY, FREE FROM STEAM, CHEMICAL FUMES, AND A MINIMUM OF 3' FROM SOURCES OF IGNITION SUCH AS ELECTRIC RELAYS, SWITCHES, MOTOR STARTERS, INCLUDING OIL OR GAS FIRED FURNACES AND WATER HEATERS.
- E. A MINIMUM OF 5' CLEAR SPACE AROUND THE METER AND REGULATOR INSTALLATION MUST BE MAINTAINED.

**NOTE: ALL MATERIALS AFTER THE SERVICE VALVE WILL BE FURNISHED AND INSTALLED BY THE CUSTOMER EXCEPT FOR THE REGULATOR WHICH IS FURNISHED BY THE COMPANY AND INSTALLED BY THE CUSTOMER. THE METER, SWIVEL AND CAPS (METER NUTS) WILL BE FURNISHED AND INSTALLED BY THE COMPANY.**

21	METER	
20	90 SERVICE SLEEVE ELBOW UNIT 1 1/2"	NON-STOCK
19	COMPRESSION COUPLING, 1" , DRESSER STYLE 90. INSULATING	9341467
18	ELBOW. 3/4" M.I.	9341308
17	PIPE SLEEVE	
16	YARN PACKING	9353980
15	FLEXIBLE SEALING COMPOUND (DUXSEAL)	9330862
14	VENT ASSEMBLY, 3/4", W / RAIN AND INSECT RESISTANT SCREEN	9358637
13	COMPRESSION COUPLING, 3/4", DRESSER STYLE 90, INSULATING	9341469
12	METER BAR, 1" X 1" X 1" 6-1/ 2" CENTERS. INSUL BARREL OUTLET	9383181
11	SHOULDER NIPPLE 1" (IF CLOSE NIPPLE USED-EXTRA HEAVY)	SHOULDER NIPPLE CLOSE NIPPLE 9340776 9340752
10	COCK, 1" PILFER – PROOF, GAS ENERGY INC. OR EQUAL	9339611
9	ELBOW, 1" M.I.	9341251
8	ELBOW, 1 1/4" X 1" M.I.	9341229
7	NIPPLE, 1 1/4" X 4" (MINIMUM)	9340736
6	REGULATOR, 1 1/4" X 1 1/4" FISHER WITH 1/4" ORIFICE S102 OR EQUAL 15 PSIG MAX.	9342623
5	NIPPLE, 1 1/4" X 6"	9340704
4	NIPPLE, 1 1/ 2" X 6"	9340738
3	REDUCING STREET ELBOW 1 1/ 2" X 1 1/ 4"	
2	STREET ELBOW, 1 1/ 2" M.I.	9341357
1	1 1/2" SERVICE VALVE TAMPER PROOF LOCK WING (LOCK CLOSED MODEL) OR EQUAL (42-11-763)	

No.	ITEM	NATIONAL GRID CODE No.
-----	------	------------------------

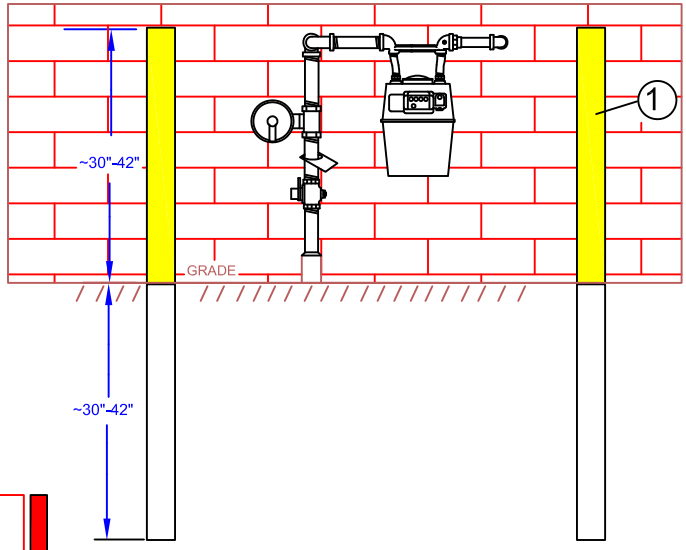
**BILL OF MATERIAL**

# GAS METER

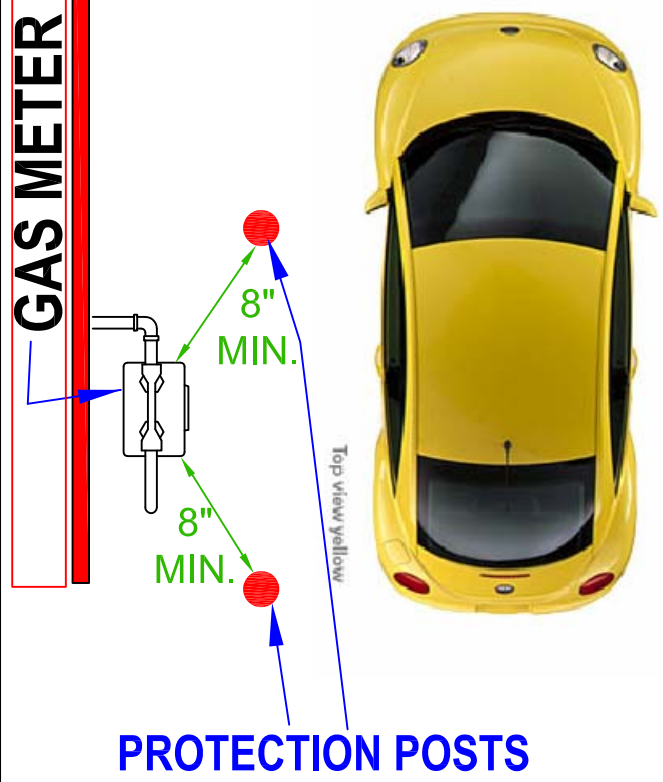


**FIGURE 1**

**HEAD ON PARKING**



# GAS METER



**FIGURE 2**

**DRIVEWAY OR ADJACENT PARKING**

**nationalgrid**

ALL REGIONS

## INSTALLATION OF PROTECTION POST OUTSIDE METER SETS

REVISIONS: MADE APPLICABLE TO ALL REGIONS

DATE: 07/01/2003

EFFECTIVE DATE: 09/15/2013

DESIGN: PG

STD. DWG.  
NO.

DRAWN: PG

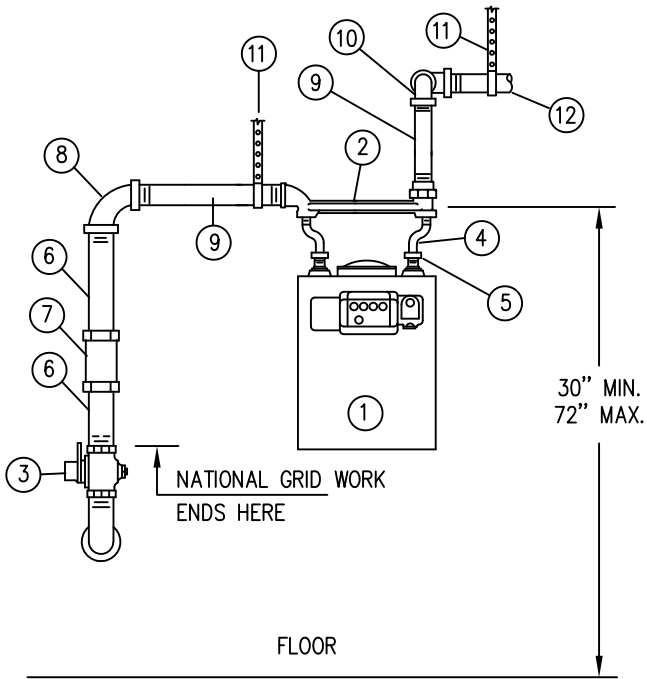
**MTRS-6060**

**NOTES:**

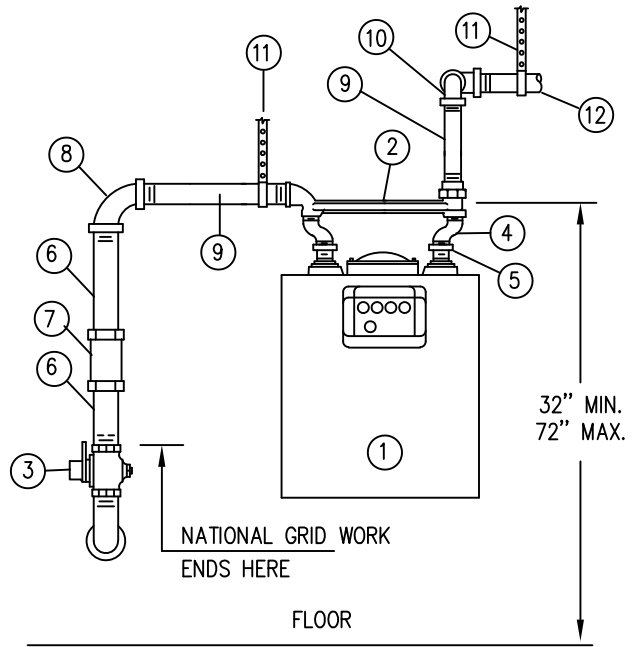
- A. WHERE PRACTICAL, CUSTOMER METERS AND SERVICE REGULATORS SHOULD BE INSTALLED IN AN AREA AWAY FROM VEHICULAR TRAFFIC AND OTHER POTENTIAL HAZARDS.
- B. WHENEVER THE METER AND/OR SERVICE REGULATOR ASSEMBLY IS POTENTIALLY SUBJECT TO DAMAGE FROM VEHICULAR TRAFFIC, AND NO OTHER MEANS OF PROTECTION EXISTS (E.G., CURB STOP, RETAINING WALL, ELEVATED PLATFORM, ETC.) PROTECTION POST(S) SHALL BE INSTALLED.
- C. EXAMPLES OF METER/SERVICE RISER LOCATIONS REQUIRING PROTECTION SHALL INCLUDE BUT NOT BE LIMITED TO:
  - 1) WHERE THE METER/SERVICE RISER IS LOCATED AT THE END OF A DRIVEWAY (SEE FIG. (1.))
  - 2) WHERE THE METER/SERVICE RISER IS LOCATED ADJACENT A DRIVEWAY (SEE FIG. (2.))
  - 3) WHERE THE METER/SERVICE RISER IS LOCATED IN A PARKING LOT
  - 4) WHERE THE METER/SERVICE RISER IS LOCATED IN A LOADING AREA
- D. RESPONSIBILITY FOR METER PROTECTION SHALL BE DETERMINED ON A CASE BY CASE BASIS.
- E. PROTECTION POSTS SHOULD MAINTAIN A MINIMUM CLEARANCE OF EIGHT (8) INCHES AROUND THE METER AND REGULATOR
- F. FOR CERTAIN COMMERCIAL AND INDUSTRIAL APPLICATIONS ADDITIONAL PROTECTION MAY BE REQUIRED IN EXCESS OF THIS POLICY DOCUMENT.
- G. THE INSTALLATION OF PROTECTION POSTS SHOULD BE DOCUMENTED ON THE GAS SERVICE RECORD CARD.
- H. THE POSTS FOR RESIDENTAL OR SMALL COMMERCIAL SETS SHOULD BE 3-1/2 OR 4 INCHES OD STEEL, PAINTED OR GALVANIZED, AND 5-7 FEET IN LENGTH. WHERE FEASIBLE, FILL POSTS WITH CONCRETE.  
**NOTE: 2" GALV. STEEL IS CURRENTLY USED IN UNY AND ACCEPTABLE FOR RESIDENTAL AND SMALL COMMERCIAL INSTALLATIONS.**
- I. THE POST SHOULD BE SET 30-42 INCHES ABOVE AND 30-42 INCHES BELOW GRADE. ALTERNATES ARE PERMISSIBLE IF THE ABOVE MATERIAL IS NOT IN STOCK. OBTAIN APPROVAL FROM YOUR SECTION MANAGER OR CHECK WITH GAS ENGINEERING IF YOU ARE UNCERTAIN.
- J. FOR CERTAIN COMMERCIAL AND INDUSTRIAL APPLICATIONS, ADDITIONAL PROTECTION MAY BE REQUIRED IN EXCESS OF THIS STANDARD

		SAP ITEM ID'S
2	CONCRETE – READY MIX 40 LB. BAG (SEE NOTE F)	9331384 LI, NYC
1	POST 3.5" O.D. 6' LONG – CONCRETE FILLED - PRIMED COATED OR POST 4.5" O.D. 5' LONG GALVANIZED 0.237" WALL – <b>NOT CONCRETE FILLED</b> POST 3.5" OD 7' LONG – CONCRETE FILLED POST 2" GALVANIZED .154" WALL + CAP FOR 2" POST POST 6" STEEL .280" WALL (FOR LARGE COMMERCIAL SETS IN UNY) + OUTER YELLOW PLASTIC SLEEVE	9340162 LI, NYC, MASS 9340113 LI, NYC, MASS 9310316 RI, MASS 9312317 UNY 9312317 UNY 9312325 UNY 9308350 UNY
NO.	ITEM	CODE No.

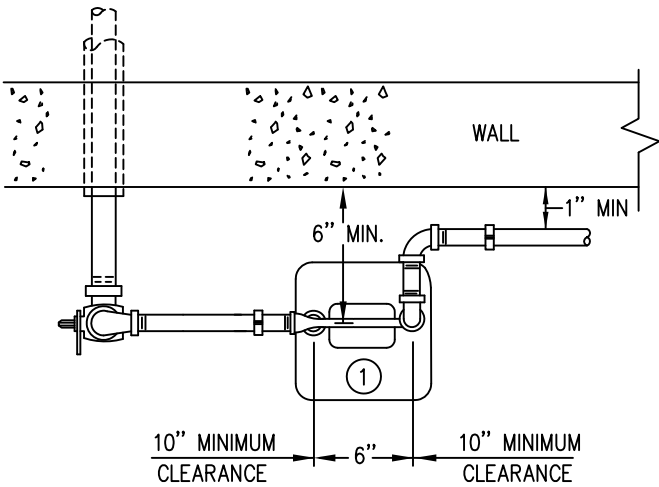
**BILL OF MATERIAL**



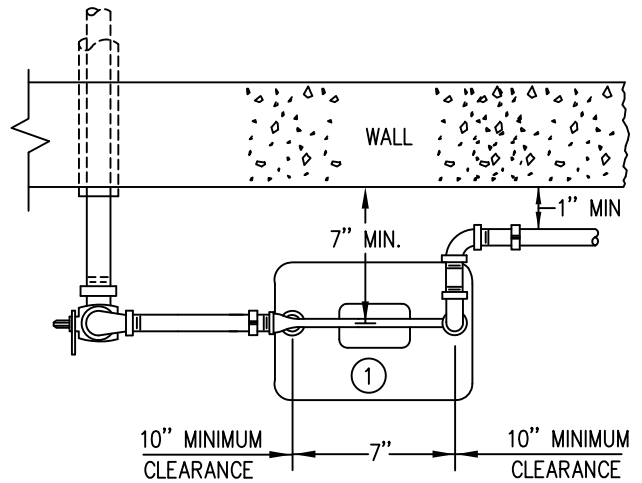
ELEVATION  
250 CFH TYPE



ELEVATION  
425 CFH TYPE



PLAN  
250 CFH TYPE



PLAN  
425 CFH TYPE

**nationalgrid**

NEW YORK CITY

**SINGLE INSIDE METER INSTALLATION  
0 - 250 CFH AND 0 - 425 CFH RANGE  
LOW PRESSURE**

**REVISIONS:** REVISED USING SAP ITEM ID #'S

DATE: 07/01/2003

EFFECTIVE DATE: 09/15/2013

DESIGN: F. TAYLOR

STD. DWG.

DRAWN: J. CASTALUCCI

NO. **MTRS-6070**

**NOTES**

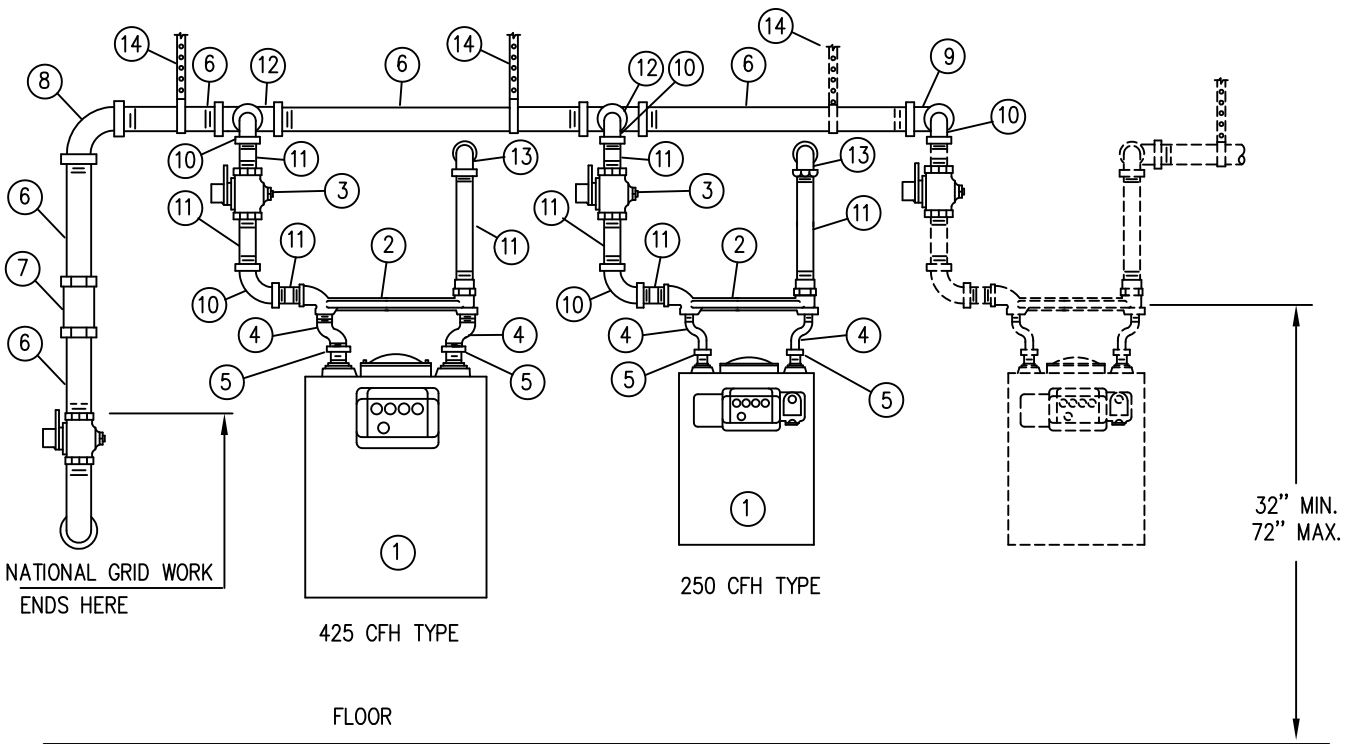
- A. KEY REQUIREMENTS FOR THE CONSTRUCTION OF METER HEADERS AND METER INSTALLATIONS ARE CONTAINED IN SPECIFICATIONS CUST-5235.
- B. IN PRIVATE HOUSE WITH SINGLE METER ONLY, METER VALVE IS PREFERRED, BUT NOT REQUIRED, PROVIDED METER IS 6' OR LESS FROM SERVICE VALVE AND ALL PIPING EXPOSED. THE SERVICE VALVE SHALL BE LOCK TYPE AND ALWAYS ACCESSIBLE.
- C. ADDITIONAL FITTINGS MAY BE REQUIRED TO MAKE THE METER INSTALLATION.

**NOTE: ALL MATERIALS AFTER THE SERVICE VALVE WILL BE FURNISHED AND INSTALLED BY THE CUSTOMER EXCEPT FOR THE REGULATOR WHICH IS FURNISHED BY THE COMPANY AND INSTALLED BY THE CUSTOMER. THE METER, SWIVEL AND CAPS (METER NUTS) WILL BE FURNISHED AND INSTALLED BY THE COMPANY.**

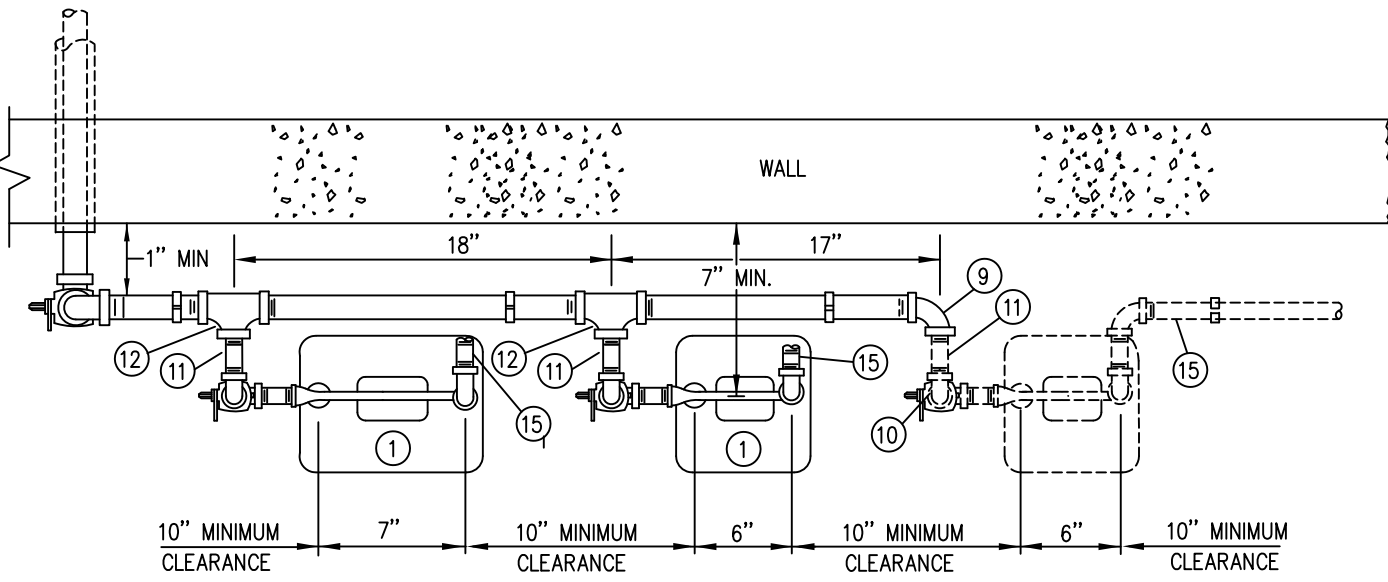
METER CHART		
METER CAPACITIES	0-250 CFH RANGE	0-425 CFH RANGE
AMERICAN	AL-250	AL-425
ROCKWELL EQUIMETER SENSUS	275	415
SPRAGUE SCHLUMBERGER ACTARIS ITRON	250	400

12	HOUSE PIPING TO LOAD	----	----
11	PIPING SUPPORT / STRAPPING	----	----
10	ELBOW, 90 M.I. SIZE OF HOUSE PIPE RISER X	1"	1-1/4"
9	NIPPLE (LENGTH AS REQUIRED)	1"	1-1/4"
8	ELBOW, REDUCING, 90 M.I. SERVICE COCK SIZE X	1"	1-1/4"
7	COMPRESSION COUPLING, INSULATING, DRESSER STYLE 90	SERVICE COCK SIZE	SERVICE COCK SIZE
6	NIPPLE 4" MINIMUM (LENGTH AS REQUIRED)	SERVICE COCK SIZE	SERVICE COCK
5	METER, CAP CONNECTION	9339504	9339622
4	METER, OFFSET SWIVEL	9342452	9342450
3	COCK, MUELLER LOCK WING, TAMPER PROOF H- 1111 OR APPROVED EQUAL	9339611	9339699
2	METER BAR SIDE INLET – TOP OUTLET ALTERNATE: METER BAR SIDE INLET – SIDE OUTLET (GALVANIZED)	1" 9339755 1" 9383181	1-1/4" 9339756 1-1/4" 9383209
1	METER	250	425

No.	ITEM	NGG CODE No.
<b>BILL OF MATERIAL</b>		



ELEVATION  
250 CFH AND 425 CFH TYPE



PLAN  
250 CFH AND 425 CFH TYPE

**nationalgrid**

NEW YORK CITY

**MULTI INSIDE METER INSTALLATION  
0 - 250 CFH AND 0 - 425 CFH RANGE  
LOW PRESSURE**

DATE: 07/01/2003

EFFECTIVE DATE: 09/15/2013

DESIGN: F. TAYLOR /PG

STD. DWG.

DRAWN: J. CASTALUCCI

NO. **MTRS-6071**

REVISIONS: UPDATED PAGE 2 TO NEW SAP ITEM ID'S

**NOTES**

- A. KEY REQUIREMENTS FOR THE CONSTRUCTION OF METER HEADERS AND METER INSTALLATIONS ARE CONTAINED IN SPECIFICATIONS CUST- 5235.
- B. THE METER PIPING LAYOUT MAY VARY SOMEWHAT FROM THIS DRAWING ACCORDING TO FIELD CONDITIONS. INSTALLATION MAY REQUIRE TWO 425 CFH TYPE AND ONE 250 CFH TYPE OR ALL OF 425 CFH RANGE METERS OR ALL 250 CFH RANGE METERS. PIPING TO MATCH REQUIRED INLET/OUTLET SPACING. LAST METER TAKEOFF FROM HEADER MANIFOLD SHALL BE FROM A REDUCING ELBOW, (ITEM 9), NOT A TEE.
- C. ADDITIONAL FITTINGS MAY BE REQUIRED TO MAKE THE METER INSTALLATION.

**NOTE: ALL MATERIALS AFTER THE SERVICE VALVE WILL BE FURNISHED AND INSTALLED BY THE CUSTOMER EXCEPT FOR THE REGULATOR WHICH IS FURNISHED BY THE COMPANY AND INSTALLED BY THE CUSTOMER. THE METER WILL BE FURNISHED AND INSTALLED BY THE COMPANY.**

METER CHART

METER CAPACITIES	0-250 CFH RANGE	0-425 CFH RANGE
AMERICAN	AL-250	AL-425
ROCKWELL EQUIMETER SENSUS	275	415
SPRAGUE SCHLUMBERGER ACTARIS ITRON	250	400

15	HOUSE PIPING TO LOAD	-----	-----
14	PIPING SUPPORT / STRAPPING	-----	-----
13	ELBOW, 90 M.I. SIZE OF HOUSE PIPE RISER X	1"	1- ¼"
12	TEE, M.I. SERVICE COCK SIZE X	1"	1-1/4"
11	NIPPLE (LENGTH AS REQUIRED)	1"	1-1/4"
10	ELBOW, 90 M.I.	1"	1- ¼"
9	ELBOW, REDUCING, 90 M.I. SERVICE COCK SIZE X	1"	1-1/4"
8	ELBOW, 90 M.I.	SERVICE COCK SIZE	SERVICE COCK SIZE
7	COMPRESSION COUPLING, INSTALLATION, DRESSER STYLE 90	SERVICE COCK SIZE	SERVICE COCK SIZE
6	NIPPLE 4" MINIMUM (LENGTH AS REQUIRED)	SERVICE COCK SIZE	SERVICE COCK SIZE
5	METER, CAP CONNECTION	9339519	9339622
4	METER, OFFSET SWIVEL	9342452	9342450
3	COCK, MUELLER, LOCK WING TAMPER PROOF, H-11118 OR APPROVED EQUAL	9339700	9339699
2	METER BAR SIDE INLET – TOP OUTLET ALTERNATE – METER BAR SIDE INLET – SIDE OUTLET - GLAVANIZED	1" 9339755 1" 9383181	1-1/4" 9339756 1-1/4" 9383209
1	METER	250 TYPE	425 TYPE

No.	ITEM	NATIONAL GRID CODE No.
-----	------	------------------------

**BILL OF MATERIAL**





**NOTES**

- A. KEY REQUIREMENTS FOR THE CONSTRUCTION OF METER HEADERS AND METER INSTALLATIONS ARE CONTAINED IN CUST-5235.
- B. ADDITIONAL FITTINGS MAY BE REQUIRED TO MAKE THE METER INSTALLATION.

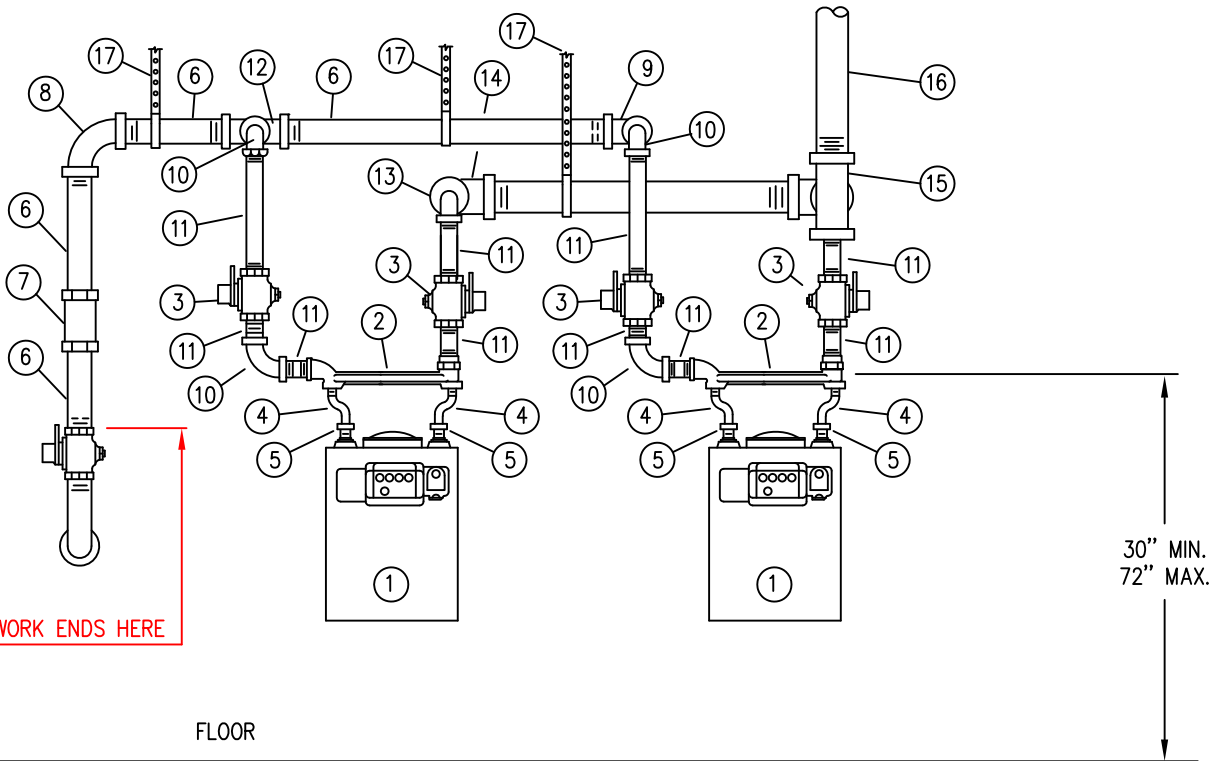
**NOTE: ALL MATERIALS AFTER THE SERVICE VALVE WILL BE FURNISHED AND INSTALLED BY THE CUSTOMER EXCEPT FOR THE REGULATOR (FOR HIGH PRESSURE INSTALLATIONS) WHICH IS FURNISHED BY THE COMPANY AND INSTALLED BY THE CUSTOMER. THE METER, SWIVEL AND CAPS (METER NUTS) WILL BE FURNISHED AND INSTALLED BY THE COMPANY.**

**METER CHART**

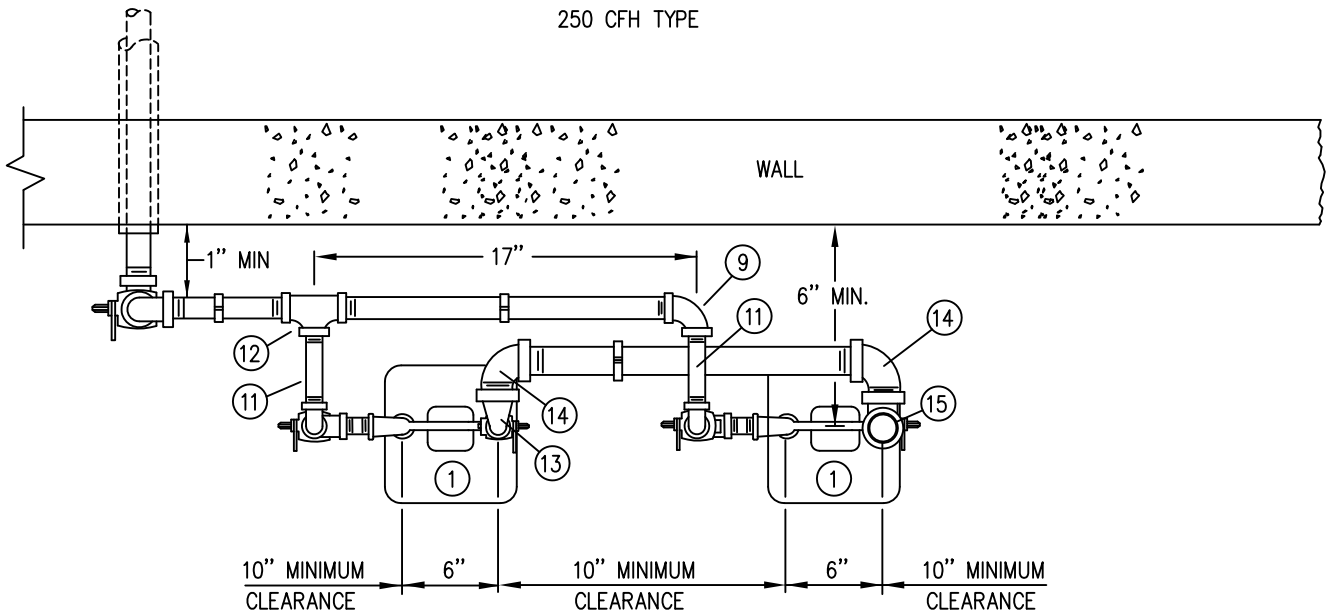
METER CAPACITIES	0-425 CFH RANGE
AMERICAN	AL-425
ROCKWELL EQUIMETER SENSUS	415
SPRAGUE SCHLUMBERGER ACTARIS ITRON	400

17	PIPING SUPPORT/STRAPPING	-----	CONTRACTOR
16	HOUSE PIPING TO LOAD	HOUSE PIPE SIZE	CONTRACTOR
15	REDUCING TEE, M.I. 1-1/4" X HOUSE PIPE SIZE X	HOUSE PIPE SIZE	CONTRACTOR
14	STREET ELBOW , 90	HOUSE PIPE SIZE	CONTRACTOR
13	ELBOW , 90 M.I., SIZE OF HOUSE PIPE RISER X	1-1/4"	CONTRACTOR
12	TEE, M.I. SERVICE COCK SIZE X	1-1/4"	CONTRACTOR
11	NIPPLE (LENGTH AS REQUIRED)	1-1/4"	CONTRACTOR
10	ELBOW, 90 M.I.	1-1/4"	CONTRACTOR
9	ELBOW, REDUCING, 90 M.I. SERVICE COCK SIZE X	1-1/4"	CONTRACTOR
8	ELBOW, 90 M.I.	SERVICE COCK SIZE	CONTRACTOR
7	COMPRESSION COUPLING, INSULATING, DRESSER STYLE 90	SERVICE COCK SIZE	CONTRACTOR
6	NIPPLE 4" MINIMUM (LENGTH AS REQUIRED )	SERVICE COCK SIZE	CONTRACTOR
5	METER, CAP CONNECTION	9339622	NAT. GRID
4	METER, OFFSET SWIVEL	9342450	NAT. GRID
3	COCK, MUELLER LOCK WING, TAMPER PROOF H-1118 OR APPROVED EQUAL	9339699	CONTRACTOR
2	METER BAR 1-1/4" SIDE INLET – TOP OUTLET METER BAR 1-1/4" SIDE INLET – SIDE OUTLET – GALVANIZED METER BAR 1" SIDE INLET – TOP OUTLET	9339756 9383209 9339755	CONTRACTOR
1	METER	425 TYPE	NAT. GRID
<b>No.</b>	<b>ITEM</b>	<b>NAT. GRID CODE NO.</b>	<b>SUPPLIED BY</b>

**BILL OF MATERIAL**



ELEVATION  
250 CFH TYPE



PLAN  
250 CFH TYPE

**nationalgrid**

NEW YORK CITY

**SIAMESE INSIDE METER INSTALLATION  
0 - 225 CFH RANGE - LOW PRESSURE**

**REVISIONS:**

REVISED USING SAP ITEM ID #'S  
REVISED ITEMS SUPPLIED BY NAT. GRID

DATE: 07/01/2003

DESIGN: F. TAYLOR

DRAWN: J. CASTALUCCI

EFFECTIVE DATE: 09/15/2013

STD. DWG.

NO. **MTRS-6081**

**NOTES**

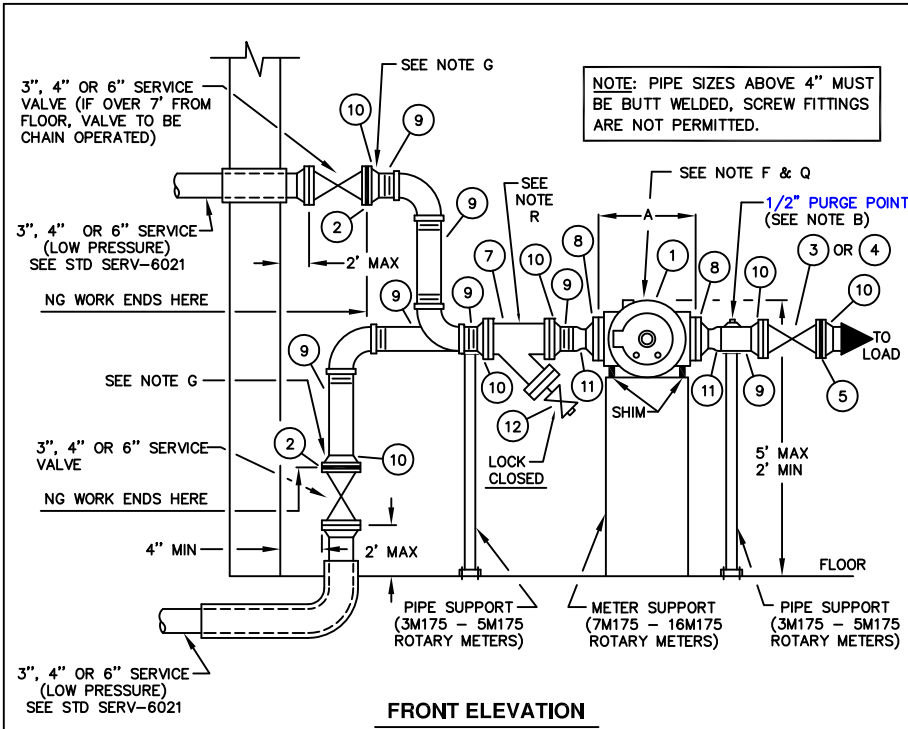
- A. KEY REQUIREMENTS FOR THE CONSTRUCTIONS OF METER HEADERS AND METER INSTALLATIONS ARE CONTAINED IN SPECIFICATIONS CUST-5235
- B. ADDITIONAL FITTINGS MAY BE REQUIRED TO MAKE THE METER INSTALLATION.

**NOTE: ALL MATERIALS AFTER THE SERVICE VALVE WILL BE FURNISHED AND INSTALLED BY THE CUSTOMER . THE METER WILL BE FURNISHED AND INSTALLED BY THE COMPANY.**

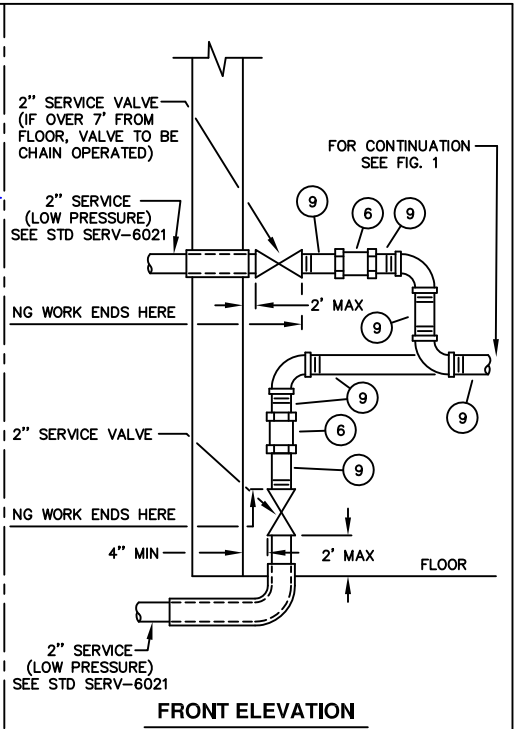
METER CHART

		METER CAPACITIES	0- 250 CFH RANGE	
		AMERICAN	AL- 250	
		ROCKWELL EQUIMETER SENSUS	275	
		SPRAGUE SCHLUMBERGER ACTARIS ITRON	250	
17	PIPING SUPPORT / STRAPPING		----	CONTRACTOR
16	HOUSE PIPING TO LOAD		HOUSE PIPE SIZE	CONTRACTOR
15	REDUCING TEE, M.I. 1" X HOUSE PIPE SIZE X		HOUSE PIPE SIZE	CONTRACTOR
14	STREET ELBOW, 90		HOUSE PIPE SIZE	CONTRACTOR
13	ELBOW 90 M.I. SIZE OF HOUSE PIPE RISER X		1"	CONTRACTOR
12	TEE, M.I. SERVICE COCK SIZE X		1"	CONTRACTOR
11	NIPPLE (LENGTH AS REQUIRED)		1"	CONTRACTOR
10	ELBOW, 90 M.I.		1"	CONTRACTOR
9	ELBOW, REDUCING, 90 M.I. SERVICE COCK SIZE X		1"	CONTRACTOR
8	ELBOW 90 M.I.		SERVICE COCK SIZE	CONTRACTOR
7	COMPRESSION COUPLING, DRESSER STYLE 90, INSULATING		SERVICE COCK SIZE	CONTRACTOR
6	NIPPLE 4" MINIMUM (LENGTH AS REQUIRED)		SERVICE COCK SIZE	CONTRACTOR
5	METER, CAP CONNECTION		9340787	CONTRACTOR
4	METER, OFFSET SWIVEL		9342452	CONTRACTOR
	ALTERNATE - METER, OFFSET SWIVEL - GALVANIZED		9383109	
3	COCK, MUELLER LOCK WING, TAMPER PROOF H -11118 OR APPROVED EQUAL		9339611	CONTRACTOR
2	METER BAR 1" SIDE INLET- TOP OUTLET		1" 9339755	CONTRACTOR
	ALTERNATE: METER BAR 1" SIDE INLET- SIDE OUTLET GALVANIZED		1" 9383181	
1	METER		250 TYPE	KED

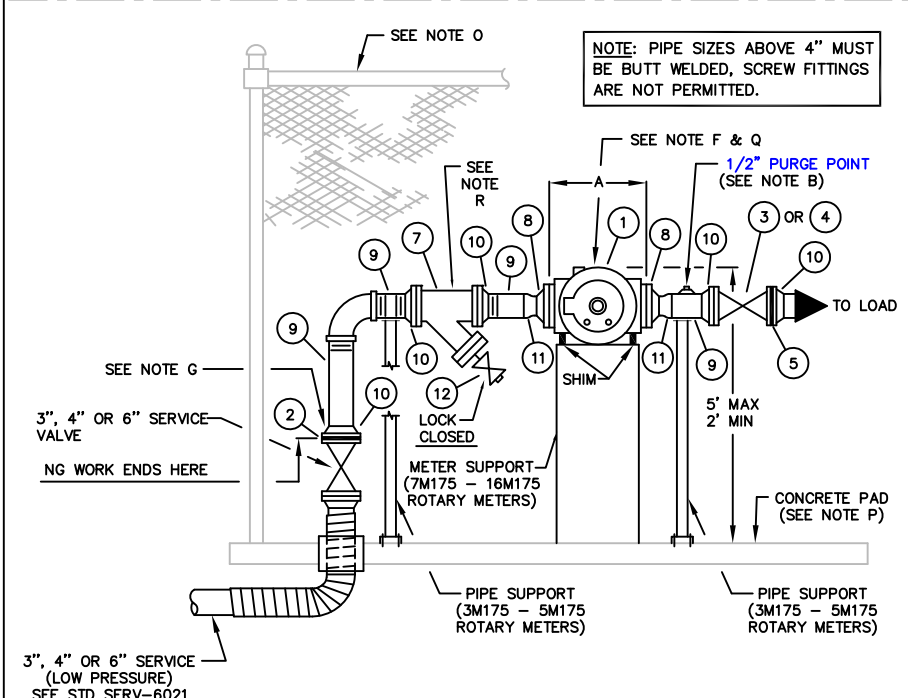
No.	ITEM	NAT. GRID
<b>BILL OF MATERIAL</b>		



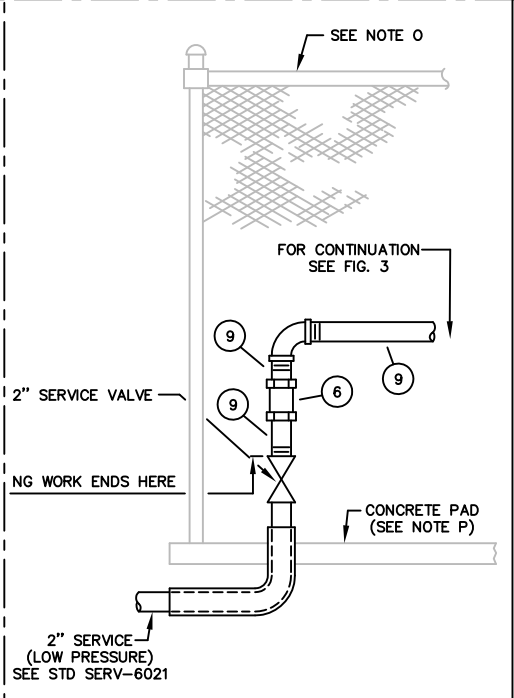
**FRONT ELEVATION**  
**FIG. 1 - INSIDE SET**  
**BASEMENT OR BASEMENTLESS BLDG.**  
**3", 4" OR 6" SERVICE**



**FRONT ELEVATION**  
**FIG. 2 - INSIDE SET**  
**BASEMENT OR BASEMENTLESS BLDG.**  
**2" SERVICE**



**FRONT ELEVATION**  
**FIG. 3 - OUTSIDE SET**  
**3", 4" OR 6" SERVICE**



**FRONT ELEVATION**  
**FIG. 4 - OUTSIDE SET**  
**2" SERVICE**

**nationalgrid**  
 NEW YORK CITY

**SINGLE ROTARY METER FOR**  
**INSIDE - OUTSIDE INSTALLATION**  
**31 CFH - 7,810 CFH RANGE**  
**LOW PRESSURE**

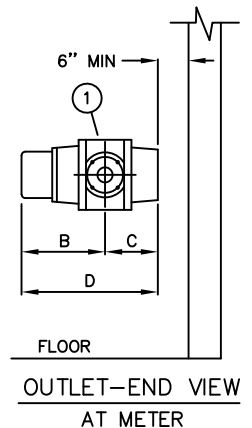
**REVISIONS:** REVISED USING SAP ITEM ID #'S

DATE: 07/01/2003	EFFECTIVE DATE: 09/15/2013
DESIGN: R. BLOISE	STD. DWG. NO.
DRAWN: P. O'NEIL	<b>MTRS-6110</b>

**NOTES**

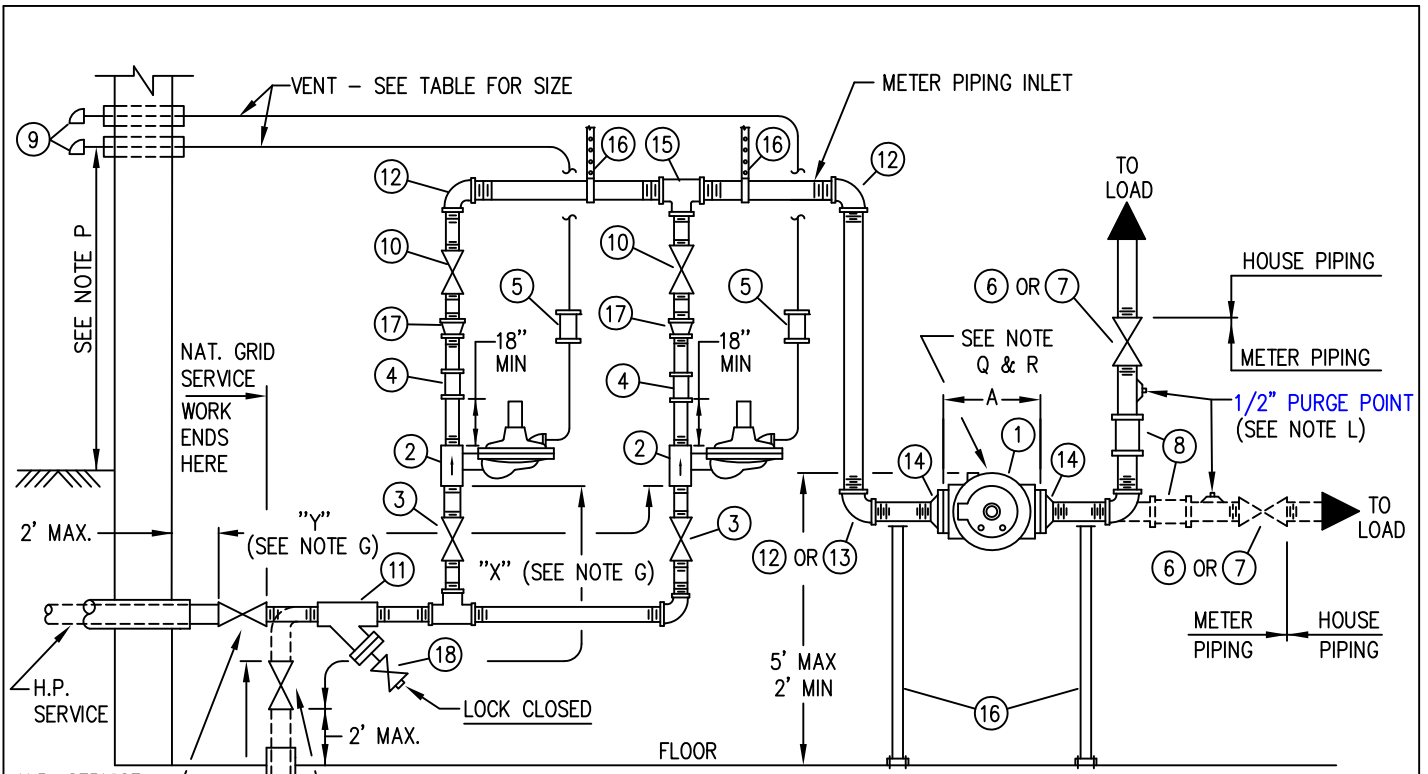
- A. **NOTE** KEY REQUIREMENTS FOR THE CONSTRUCTION OF METER HEADERS AND METER INSTALLATION ARE CONTAINED IN NATIONAL GRID SPECIFICATIONS CMS-03002
- B. **PURGE POINT SHALL BE A 1/2" THRED-O-LET. ALL THRED-O-LETS SHALL BE INSTALLED ON STRAIGHT PIPE, NOT ON FITTINGS. MIN. DISTANCE BETWEEN THRED-O-LETS SHALL BE 3" FROM EDGE OF FILLET WELD TO EDGE OF FILLET WELD. MIN. DISTANCE BETWEEN THRED-O-LETS & BUTT WELDS SHALL BE 4" FROM EDGE OF FILLET WELD TO EDGE OF BUTT WELD. A SCREWED REDUCING TEE MAY BE USED AS AN ALTERNATE TO A THRED-O-LET.**
- C. WHERE VEHICULAR TRAFFIC IS A CONCERN, INSTALL DEADMEN. SEE STD MTRS-6060 FOR PROTECTION POST INSTALLATION REQUIREMENTS AND SPECIFICATIONS.
- D. METERS AND SAFETY DEVICES MUST BE PROTECTED FROM DAMAGE DURING PRESSURE TEST.
- E. PILOT GAS FROM FIRM LOAD METER - IF REQUIRED. (SEE NOTE J).
- F. DO NOT WELD WITH METER IN LINE - USE SPOOL PIECE.
- G. BLIND FLANGE WITH 3/4" TAP HOLE AND PLUG TO BE RETURNED TO STOCK BY FIELD OPERATIONS TO STOREROOM, AS PER STD. DWG. S-002.
- H. ADDITIONAL FITTINGS MAY BE REQUIRED TO MAKE THE METER INSTALLATION.
- I. NATIONAL GRID SHALL NOT BE RESPONSIBLE FOR FITTING DIMENSIONS OR FOR SCALED DIMENSIONS.
- J. IF BRANCH LOAD IS REQUIRED, SEE APPROPRIATE DRAWINGS FOR METER SIZING, PIPE DESIGN AND VALVE REQUIREMENTS. BRANCH PIPING IS TO BE ELECTRICALLY INSULATED FROM DISTRIBUTION PIPING AT VALVE.
- K. DEPENDING ON THE SERVICE LOCATION, THE SERVICE VALVE MAY BE INSTALLED STRAIGHT OR IN THE HORIZONTAL OR VERTICAL POSITION.
- L. COAT ALL PIPE AND FITTINGS WITH RUSTOLEUM #7715 OR EQUAL. TWO COATS REQUIRED, BRUSH APPLIED.
- M. FOR UNDERGROUND PIPING AFTER METER, CONTACT GAS ENGINEERING GROUP FOR NATIONAL GRID REQUIREMENTS.
- N. ALL MAXIMUM CFH'S ARE MEASURED AT 0.5" WATER COLUMN DROP ACROSS THE METER.
- O. A FULLY ENCLOSED (INCLUDING TOP) CHAIN LINK FENCE (CYCLONE) MINIMUM 8 FT. HIGH WITH GATE AND LOCK REQUIRED ON ALL OUTSIDE SETS. TO BE SUPPLIED BY CUSTOMER.
- P. CONCRETE PAD FOR METER, 4" THICK, 5 FT WIDE, LENGTH DETERMINED BY LENGTH OF THE METER PIPING. TO BE SUPPLIED BY CUSTOMER.
- Q. THE METER IS DESIGNED FOR DIRECT IN-THE-LINE MOUNTING AND LEVEL POSITION. THE ALTERNATE INSTALLATION IS TOP INLET IN A VERTICAL LINE, GAS FLOW BEING DOWNWARD.
- R. IF STRAINER AND METER FLANGE ENDS ARE BOTH COMPATIBLE IN SIZE, TYPE AND PRESS RATING AND THERE IS ADEQUATE CLEARANCE FOR MAINTENANCE, EQUIPMENT MAY BE INSTALLED BACK TO BACK. THE STRAINER MAY ALSO BE INSTALLED IN THE VERTICAL POSITION, FACING DOWNWARD ONLY.

ROOTS ROTARY METERS TEMPERATURE COMPENSATED											
MODEL TQM	CAPACITY IN CFH		MODEL LMM	CAPACITY IN CFH		DIMENSIONS				METER PIPE SIZE	BODY TYPE
	MIN	MAX		MIN	MAX	A	B	C	D		
8C175	31	800	----	----	----	6-3/4"	11-13/32"	4-11/16"	16-3/32"	2"	FLANGED
11C175	35	1,100	----	----	----	6-3/4"	11-21/32"	4-15/16"	16-19/32"	2"	FLANGED
15C175	38	1,500	----	----	----	6-3/4"	12-5/32"	5-13/32"	17-9/16"	2"	FLANGED
----	----	----	1.5M175	100	1,200	6-1/16"	10-1/4"	4-9/16"	14-13/16"	1-1/2"	SCREWED
2M175	29	2,000	----	----	----	6-3/4"	12-1/16"	5-21/32"	17-23/32"	2"	FLANGED
3M175	39	2,580	3M175	100	2,220	6-3/4"	12-11/16"	6-1/4"	18-15/16"	2"	FLANGED
5M175	42	3,975	5M175	100	3,350	6-3/4"	14-1/8"	7-11/16"	21-13/16"	3"	FLANGED
7M175	104	5,400	7M175	350	4,620	9-1/2"	13-1/8"	6-1/2"	19-5/8"	3"	FLANGED
11M175	89	7,300	11M175	400	7,810	9-1/2"	14-29/32"	8-9/32"	23-3/16"	4"	FLANGED

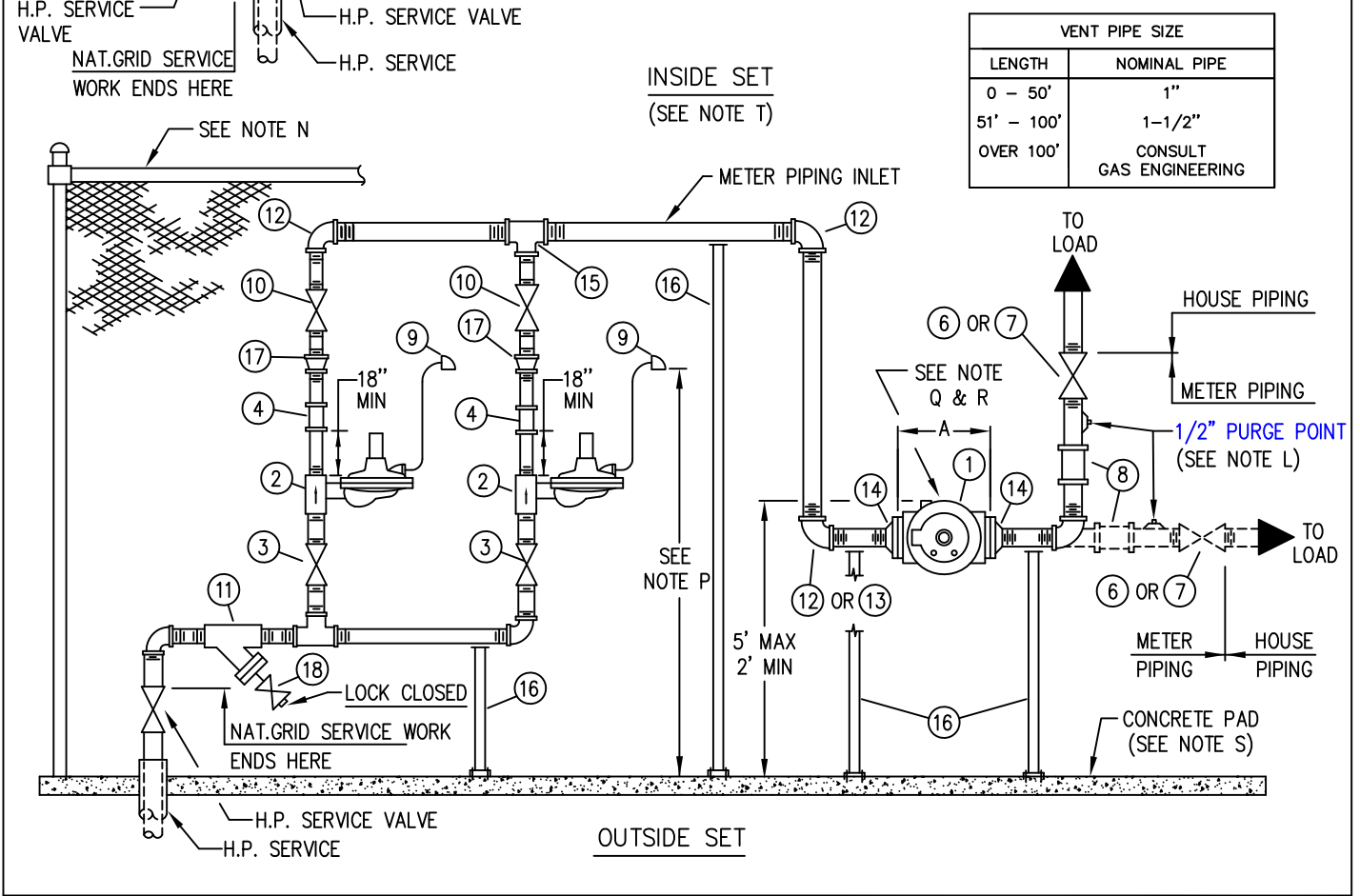


12	PLUG VALVE, NORDSTROM FIG 114 WITH LOCK VALVE, LOCKWING, MUELLER LUB-O-LOK H-11159B, LOCK CLOSED VALVE, LOCKWING, MUELLER TAMP-R-LOK H-11119B, LOCK CLOSED	----- ----- 1-1/4"	----- ----- 1-1/4"	----- ----- 1-1/2"	2" ----- -----	NAT. GRID
11	FORGED STEEL CONCENTRIC REDUCER OR SCREWED FITTING (ABOVE 4" TO BE WELDED) SIZE TO BE DETERMINED BY METER AND SERVICE SIZE; NOT REQUIRED IF SERVICE SIZE IS SAME AS METER SIZE)	SERVICE SIZE x METER SIZE	SERVICE SIZE x METER SIZE	SERVICE SIZE x METER SIZE	SERVICE SIZE x METER SIZE	CONTRACTOR
10	FLANGE, 150# ANSI F-F STEEL, WELD NECK OR SCREWED (ABOVE 4" TO BE WELDED)	2"	3"	4"	6"	CONTRACTOR
9	NIPPLE, MINIMUM LENGTH	2" 8-1/2"	3" 12"	4" 12"	6" 12"	CONTRACTOR
8	FLANGE, 150# ANSI F-F STEEL, WELD NECK OR SCREWED	SAME SIZE AS METER PIPE SIZE	SAME SIZE AS METER PIPE SIZE	SAME SIZE AS METER PIPE SIZE	SAME SIZE AS METER PIPE SIZE	CONTRACTOR
7	STRAINER, MUELLER "Y", OR APPROVED EQUAL	2" 9340158	3" 9340182	4" 9340157	6" 9340186	CONTRACTOR
6	COMPRESSION COUPLING, DRESSER STYLE 90, INSULATING	2" 9341468	-----	-----	-----	CONTRACTOR
5	INSULATING KIT FOR 150# ANSI F-F STEEL FLANGE	2" 9340992	3" 9340959	4" 9341024	6" 9341026	NAT. GRID
4	PLUG VALVE, NORDSTROM FIG. 143 F-F FLANGED, OR APPROVED EQUAL	-----	-----	-----	6" 9341983	CONTRACTOR
3	PLUG VALVE, NORDSTROM FIG. 143 F-F FLANGED, OR APPROVED EQUAL	2" 9341980	3" 9341981	4" 9382541	-----	CONTRACTOR
2	INSULATING KIT FOR 150# ANSI F-F STEEL FLANGE	-----	3" 9340959	4" 9341024	6" 9341026	NAT. GRID
1	METER, (DRESSER) ROOTS ROTARY TEMPERATURE COMPENSATED	SEE TABLE ABOVE	SEE TABLE ABOVE	SEE TABLE ABOVE	SEE TABLE ABOVE	NAT. GRID
		2" SERVICE	3" SERVICE	4" SERVICE	6" SERVICE	

**NOTE: ALL MATERIALS AFTER THE SERVICE VALVE WILL BE FURNISHED AND INSTALLED BY THE CUSTOMER EXCEPT FOR THE REGULATOR WHICH IS FURNISHED BY THE COMPANY AND INSTALLED BY THE CUSTOMER. THE METER, GASKETS AND METER BOLTS WILL BE FURNISHED AND INSTALLED BY THE COMPANY.**



VENT PIPE SIZE	
LENGTH	NOMINAL PIPE
0 - 50'	1"
51' - 100'	1-1/2"
OVER 100'	CONSULT GAS ENGINEERING



**nationalgrid**

NEW YORK CITY

**HIGH PRESSURE ROTARY METER REGULATOR SET**  
**15 PSIG 775 - 1550 CFH & 60 PSIG 470 - 940 CFH RANGE**  
**INDOOR - OUTDOOR SET**

**REVISIONS:** REVISED USING SAP ITEM ID #'S  
 REVISED ITEMS SUPPLIED BY CUSTOMER

DATE: 07/01/2003  
 DESIGN: B. BLOISE  
 DRAWN: P. O'NEIL

EFFECTIVE DATE: 09/15/2013  
 STD. DWG. NO. **MTRS-6130**



**NOTES**

- A. NOTE KEY REQUIREMENTS FOR THE CONSTRUCTION OF METER HEADERS AND METER INSTALLATION ARE CONTAINED IN NAT. GRID SPECIFICATIONS GENG-2010.
- B. ADDITIONAL FITTINGS MAY BE NEEDED TO MAKE THE METER INSTALLATION.
- C. NAT. GRID SHALL NOT BE RESPONSIBLE FOR FITTING DIMENSIONS OR FOR SCALED DIMENSIONS.
- D. RECOMMENDED SETTINGS FOR REGULATORS AS FOLLOWS.
  - (A) ONE SET AT 6" W.C. AND THE SECOND SET AT 5.5" W.C. FOR NEW INSTALLATIONS.
  - (B) ONE SET AT 6.5" W.C. AND THE SECOND SET AT 6" W.C. FOR EXISTING INSTALLATIONS.
- E. A MAXIMUM SETTING OF 8" W.C. IS TO BE USED ONLY WHEN THERE IS A PROBLEM OF UNDER FIRE EQUIPMENT (FOR EXISTING INST. ONLY).
- F. ALWAYS SET THE OUTLET OF THE REGULATOR SO THERE IS 0.5" W.C. DIFFERENTIAL IN STATIC PRESSURE POINTS.
- G. IF LENGTHS "X" OR "Y" ARE GREATER THAN 4'-0" AND DO NOT EXCEED 9'-0", A METER ROOM WITH THREE (3) HOUR FIRE RATING CONSTRUCTION AND ADEQUATE VENTILATION IS REQUIRED. FOR INSTALLATION GREATER THAN 9'-0", CONTACT SYSTEM DESIGN SECTION, DFS.
- H. A MINIMUM OF 5'-0" OF CLEAR SPACE AROUND THE METER AND REGULATOR INSTALLATION MUST BE MAINTAINED.
- I. FOR FLOW RATES BELOW 470 CFH (60 PSIG SYSTEM) SEE STANDARD DRAWING MTRS – 6140
- J. FOR FLOW RATES BELOW 775 CFH (15 PSIG SYSTEM) SEE STANDARD DRAWING MTRS – 6160 AND MTRS – 6050
- K. FOR FLOW RATES THAN 940 CFH (60 PSIG SYSTEM) OR 1550 CFH (15 PSIG SYSTEM) SEE SPECIAL ENGINEERING METER AND REGULATOR LAYOUT.
- L. PURGE POINTS SHALL BE 1/2" THREADOLET, OR A SCREW REDUCING TEE MAY BE USED AS AN ALTERNATE. SAM LOCK PLUGS TO BE INSTALLED BY FIELD SERVICE IF REQUIRED.
- M. VERTICAL PIPE SUPPORTS SHALL BE ADEQUATELY SEALED FROM WATER INFILTRATION AND PROPERLY COATED TO RESIST CORROSION.
- N. FOR OUTSIDE SETS, A FULLY ENCLOSED (INCLUDING TOP) CHAIN LINK FENCE MAY BE REQUIRED, DEPENDING ON AREA OR METER LOCATION. FENCE GATE SHALL HAVE CHAIN WITH DOUBLE LOCK, ONE PADLOCK AND ONE BULLET LOCK.
- O. COAT ALL PIPE AND FITTINGS WITH RUSTOLEUM #7715 OR EQUAL. TWO COATS REQUIRED, BRUSH APPLIED. ALSO SERVICE VALVE MUST BE PAINTED RED.
- P. REGULATOR VENT HEAD ASSEMBLY MUST FACE DOWN. VENT TERMINUS MUST BE A MINIMUM OF 6 FT. ABOVE OUTSIDE GRADE FOR NON-DOMESTIC AND 18" FOR DOMESTIC INSTALLATIONS. A MINIMUM OF 18" MUST BE MAINTAINED FROM ANY OPENINGS.
- Q. DO NOT WELD WITH METER IN LINE-USE SPOOL PIECE.
- R. THE METER IS DESIGNED FOR DIRECT IN –THE-LINE MOUNTING AND LEVEL POSITION. THE ALTERNATE INSTALLATION IS TOP INLET IN A VERTICAL LINE, GAS FLOW BEING DOWNWARD.
- S. CONCRETE PAD FOR METER TO BE 4" THICK, 5' WIDE, LENGTH TO BE DETERMINED BY LENGTH OF METER RUN.
- T. INSIDE INSTALLATION OF STRAINERS PERMITTED WHEN OUTSIDE INSTALLATION IS IMPRACTICABLE. FOR FURTHER CLARIFICATION CONTACT STANDARDS AND PRACTICES SECTION NAT. GRID.

18	COCK, LOCK WING, LUB-O-SEAL, MUELLER H11175, LOCK CLOSED OR APPROVED EQUAL		3/4"	3/4"	NAT. GRID
17	REDUCER	15 PSIG SERVICE 60 PSIG SERVICE	1-1/2"X1-1/4" 1-1/2"X1"	1-1/2"X1-1/4" 1-1/2"X1"	customer
16	PIPE STRAPS/SUPPORT (NEOPRENE OR EQUAL BETWEEN THE SUPPORT AND THE PIPE) SEE NOTE M		LENGTH AS REQ'D	LENGTH AS REQ'D	customer
15	TEE, M.I.		1-1/2"	1-1/2"	customer
14	FLANGE, 150# ANSI F-F STEEL, WELD NECK OR SCREWED		-----	2"	customer
13	REDUCING ELBOW, M.I.		-----	2"x1-1/2"	customer
12	ELBOW, M.I.		1-1/2"	1-1/2"	customer
11	STRAINER, 260C, SCREWED (SEE NOTE T)	(15 PSIG) 1- 1/4" (60 PSIG) 3/4"	9340160 9340181	9340160 9340181	customer
10	COCK, LOCK WING, LUB-O-SEAL, MUELLER H-11175 OR APPROVED EQUAL		1-1/2" 9339661	1 - 1/2" 9339661	customer
9	VENT ASSEMBLY WITH RAIN AND INSECT RESISTANT SCREEN (SEE VENT TABLE FOR SIZE)	1" 1- 1/2"	9358640 9358641	9358640 9358641	customer
8	COMPRESSION COUPLING, DRESSER STYLE 90, INSULATED		1 - 1/2" 9341465	2" 9341468	customer
7	COCK, LOCK WING, LUB-O-SEAL, MUELLER H-11175 OR APPROVED EQUAL		1-1/2" 9341980	-----	customer
6	PLUG VALVE, NORDSTROM FIG. 114 OR APPROVED EQUAL		-----	2" 9341953	customer
5	COMPRESSION COUPLING, DRESSER STYLE 90, INSULATED (SEE VENT TABLE FOR SIZE)	1" 1-1/2"	9341467 9341465	9341467 9341465	customer
4	COMPRESSION COUPLING, DRESSER STYLE 90, INSULATED	(15 PSIG) 1-1/4" (60 PSIG) 1"	9341466 9341467	9341466 9341467	customer
3	COCK, LOCK WING, LUB-O-SEAL, MUELLER H11175 OR APPROVED EQUAL	(15 PSIG) 1-1/4" (60 PSIG) 3/4"	9339699 9339701	9339699 9339701	customer
2	REGUALTOR, WITH 1/4" ORIFICE (15# MAX INLET) OR EQ. 1-1/4"X1-1/4" REGUALTOR, WITH 3/16" ORIFICE (60# MAX INLET) OR EQ. 1-1/4"X1-1/4" REGULATOR, WITH 1/8" ORIFICE (60# MAX INLET) OR APPROVED EQ. 3/4"X 1"		9342623 9342206 9383047	9342623 9342206 9383047	NAT. GRID
1	METER, (DRESSER) ROOTS ROTARY, TEMPERATURE COMPENSATED (SEE TABLE ABOVE) 1-1/4" SERVICE (15 PSIG) AND 3/4" SERVICE (60 PSIG)		1.5M175	15C175 11C175 8C175	NAT. GRID

#	ITEM	NAT. GRID CODE No.
---	------	--------------------

**NOTE: ALL MATERIALS AFTER THE SERVICE VALVE WILL BE FURNISHED AND INSTALLED BY THE CUSTOMER EXCEPT FOR THE REGULATOR, SECURITY VALVE AND EXTERNAL RELIEFS - IF APPLICABLE (FOR HIGH PRESSURE INSTALLATIONS) WHICH IS FURNISHED BY THE COMPANY AND INSTALLED BY THE CUSTOMER. THE METER, METER GASKETS, NUTS AND BOLTS WILL BE FURNISHED BY THE COMPANY.**





**NOTES**

- A. KEY REQUIREMENTS FOR THE CONSTRUCTION OF METER HEADERS AND INSTALLATIONS ARE CONTAINED IN NATIONAL GRID'S SPECIFICATIONS CUST-5235 AND THE NATIONAL GRID BLUE BOOK
- B. ADDITIONAL FITTINGS MAY BE REQUIRED TO MAKE THE METER AND REGULATOR INSTALLATION.
- C. NATIONAL GRID SHALL NOT BE RESPONSIBLE FOR FITTING DIMENSIONS OR FOR SCALED DIMENSIONS.
- D. FOR FLOW RATES GREATER THAN 630 CFH SEE MTRS-6185-LI OR MTRS-6120-NYC & MTRS-6121-NYC FOR DUAL REGULATOR CONFIGURATIONS
- E. FOR FLOW RATES GREATER THAN 1000 CFH (60 PSIG SYSTEM) OR 960 CFH (15 PSIG SYSTEM), CONTACT GAS ENGINEERING FOR SPECIAL ENGINEERING METER AND REGULATOR LAYOUT.
- F. **REGULATOR VENT MUST FACE DOWN AND BE EQUIPPED WITH A RAIN AND INSECT RESISTANT SCREEN. FOR NEW CONSTRUCTION OR ALTERATIONS SEE 020013-CS VENT PIPING LOCATION. IT IS PREFERRED THAT REGULATOR VENTS BE INSTALLED AT A HEIGHT 18 INCHES ABOVE GRADE, HOWEVER, THE MINIMUM ALLOWABLE VENT HEIGHT SHALL BE 12 INCHES ABOVE FINAL GRADE. IN CASES OF KNOWN FLOOD LOCATIONS, THE PREFERRED REGULATOR VENT HEIGHT ABOVE THE FLOOD HEIGHT IS 18" (12" MINIMUM). THE REGULATOR VENT SHALL BE 18" (WHERE PRACTICAL) FROM ANY OPENING WHICH COULD ALLOW VENTED GAS TO ENTER.**
- G. SERVICE VALVE MUST BE PAINTED RED (IN NEW YORK CITY ONLY).
- H. WHERE VEHICULAR TRAFFIC IS A CONCERN, INSTALL PROTECTION POST. SEE STANDARD DRAWING MTRS-6060 FOR INSTALLATION REQUIREMENTS.
- I. CPR TAGS ARE REQUIRED IN LONG ISLAND INSTALLATIONS ONLY.
- J. WALL SLEEVES ARE ONLY REQUIRED WHEN SERVICE PENETRATES CONCRETE OR MASONRY WALL. WALL SLEEVES ARE RECOMMENDED, BUT NOT REQUIRED THROUGH STUCCO OR FRAME CONSTRUCTION.
- K. THE CLASS 400 METERS HAVE 30 LIGHT CONNECTIONS IN NEW YORK CITY AND 45 LIGHT CONNECTIONS IN LONG ISLAND. THE CLASS 630 METERS WILL HAVE 45 LIGHT CONNECTIONS IN NYC AND LI.
- L. THE PIPE AND FITTING LISTED BELOW ARE GALVANIZED. BLACK PIPE AND FITTINGS THAT ARE PRIMED AND PAINTED ARE ALSO ACCEPTABLE. **NOTE FOOTNOTES ON METER & SWIVELS B = BLACK, G = GALVANIZED**

METER CAPACITIES	0-250 CFH RANGE	0-425 CFH RANGE	0-630 CFH RANGE
AMERICAN	250	425	630
EQUIMETER/SENSUS	275	415	
ACTARIS/ITRON	250	400	

		250 METER SET	400 & 630 METER SET	SUPPLIED BY			
20	SYSTEM PRESSURE TAG	9346233	9346233	NGG			
19	METER VALVE, LOCK WING GALVANIZED	9339593	9339609	NGG			
18	CPR TAG (LONG ISLAND ONLY)	9340255	9340255	NGG			
17	WALL SLEEVE – PVC PLASTIC PIPE OR STD. WT STEEL PIPE (2" LONGER THAN WALL THICKNESS)	---	---	CUSTOMER			
16	STREET ELBOW 90 DEGREE GALVANIZED	9341192	9341193	CUSTOMER			
15	PROTECTION POST (SEE NOTE H)	---	---	CUSTOMER			
14	YARN, PACKING	---	---	CUSTOMER			
13	FLEXIBLE SEALING COUMPOUND (DUXSEAL)	---	---	CUSTOMER			
12	HOUSE PIPING TO LOAD	---	---	CUSTOMER			
11	ELBOW 90 DEGREES M.I., SIZE OF HOUSE PIPE (GALV.)	1"	1-1/4"	CUSTOMER			
10	NIPPLE, 3" MINIMUM GALVANIZED (LENGTH AS REQUIRED)	1" 9340641	1-1/4" 9340652	CUSTOMER			
9	ELBOW/REDUCING ELBOW 90 DEG M.I. GALVANIZED	1" 9341181	1"X1-1/4" 9341185	CUSTOMER			
8	NIPPLE 1" X 3" MINIMUM (LENGTH AS REQUIRED)	1" 9340641	1" 9340641	CUSTOMER			
7	NIPPLE 3/4" X 4" MINIMUM (LENGTH AS REQUIRED)	3/4" 9340633	3/4" 9340633	CUSTOMER			
6	VENT ASSEMBLY WITH INSECT RESISTANT SCREEN IF REQ'D, 1"	9358640	9358640	NGG			
5	METER CAP/NUT CONNECTION SEE NOTE K	NEW YORK CITY 250 & 400	9340787 <sup>G</sup> 9339519 <sup>B</sup>	1-1/4" 30 LT	9383207 <sup>G</sup> 9339622 <sup>B</sup>	NGG	
		NEW YORK CITY 630 CLASS	---	1-1/4" 45 LT	9339623	NGG	
		LONG ISLAND 250/400/630	9340787	1-1/4" 45 LT	9340788	NGG	
4	METER SWIVEL OFFSET GALV. SEE NOTE K	NEW YORK CITY 250 & 400	1" 9383109 <sup>G</sup> 9342452 <sup>B</sup>	1-1/4" 30 LT	9383108 <sup>G</sup> 9342456 <sup>B</sup>	NGG	
		NEW YORK CITY 630 CLASS	-	-	1-1/4" 45 LT		9386167
		LONG ISLAND 250/400/630	1" 9383109	1-1/4" 45 LT	9342425		
3	REGULATOR, 3/4" X 1" WITH 1/8" ORIFICE: FISHER HSR , ITRON B-42R OR B-31R, SENSUS 143-80-2, AMERICAN 1813B2 OR SR100	9383047	9383047	9383047	NGG		
2	METER BAR, W/INSUL. OUTLET, GALV. AY MCD#6610-GCCD OR EQ METER BAR, W/INSUL. OUTLET, GALV. AY MCD#6640-GCCD OR EQ METER BAR, W/INSUL. OUTLET, BLACK WITH TOP OUTLET	1" X 1" X 1" 9383181	---	---	NGG		
		9339755	1-1/4" X 1-1/4" 9383209	1-1/4" X 1-1/4" 9339756			
1	METER (TEMPERATURE COMPENSATED)	250 CLASS	400 & 630 CLASS				
<b>No.</b>	<b>ITEM</b>			<b>ITEM ID</b>			

**NOTE: IN NYC, ALL MATERIALS AFTER THE SERVICE VALVE WILL BE FURNISHED AND INSTALLED BY THE CUSTOMER EXCEPT FOR THE REGULATOR WHICH IS FURNISHED BY THE COMPANY AND INSTALLED BY THE CUSTOMER. THE METER, SWIVEL AND CAPS (METER NUTS) WILL BE FURNISHED AND INSTALLED BY THE COMPANY. IN LONG ISLAND, NATIONAL GRID WILL INSTALL TO THE METER BAR.**



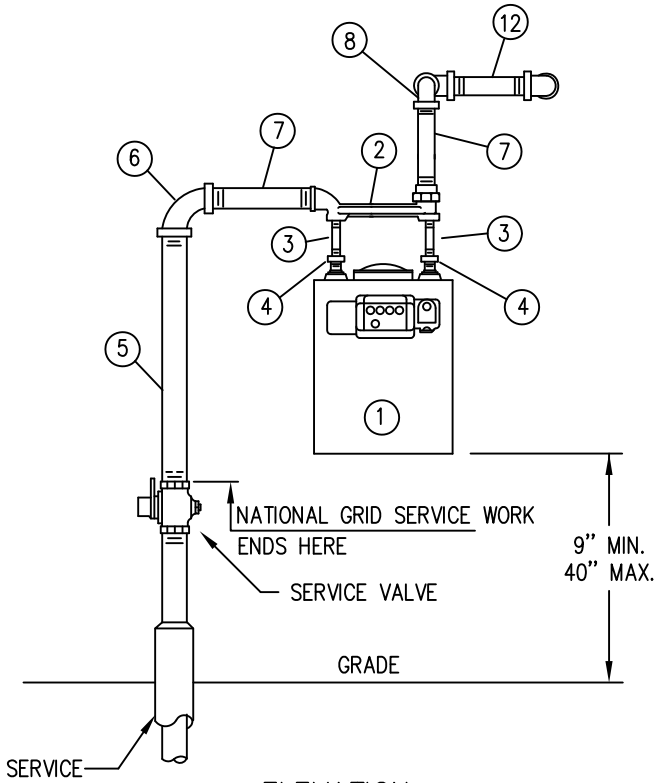
**NOTES:**

- A. KEY REQUIREMENTS FOR THE CONSTRUCTION OF METER HEADERS AND INSTALLATIONS ARE CONTAINED IN NATIONAL GRID'S SPECIFICATIONS CUST-5235.
- B. ADDITIONAL FITTINGS MAY BE REQUIRED TO MAKE THE METER AND REGULATOR INSTALLATION.
- C. NATIONAL GRID SHALL NOT BE RESPONSIBLE FOR FITTING DIMENSIONS OR FOR SCALED DIMENSIONS.
- D. IN NYC, FOR FLOW RATES BETWEEN 630 CFH AND 820 CFH (60# SYSTEM) AND 630 CFH AND 960 CFH (15# SYSTEM) SEE STANDARD DRAWING MTRS-6120 & MTRS-6121.
- E. IN NYC, FOR FLOW RATES GREATER THAN 820 CFH (60 PSIG SYSTEM) OR 960 CFH (15 PSIG SYSTEM) SEE SPECIAL ENGINEERING METER AND REGULATOR LAYOUT.
- F. **REGULATOR VENT MUST FACE DOWN AND BE EQUIPPED WITH A RAIN AND INSECT RESISTANT SCREEN. FOR NEW CONSTRUCTION OR ALTERATIONS SEE 020013-CS VENT PIPING LOCATION. IT IS PREFERRED THAT REGULATOR VENTS BE INSTALLED AT A HEIGHT 18 INCHES ABOVE GRADE, HOWEVER, THE MINIMUM ALLOWABLE VENT HEIGHT SHALL BE 12 INCHES ABOVE FINAL GRADE. IN CASES OF KNOWN FLOOD LOCATIONS, THE PREFERRED REGULATOR VENT HEIGHT ABOVE THE FLOOD HEIGHT IS 18" (12" MINIMUM). THE REGULATOR VENT SHALL BE 18" (WHERE PRACTICAL) FROM ANY OPENING WHICH COULD ALLOW VENTED GAS TO ENTER.**
- G. SERVICE VALVE MUST BE PAINTED RED (IN NEW YORK CITY ONLY).
- H. WHERE VEHICULAR TRAFFIC IS A CONCERN, INSTALL PROTECTION POST. SEE STANDARD DRAWING MTRS-6060 FOR INSTALLATION REQUIREMENTS.
- I. CPR TAGS ARE REQUIRED IN LONG ISLAND INSTALLATIONS ONLY.
- J. WARNING ON 99 PSIG AND 124 PSIG SERVICES, THE ORIFICE MUST 1/8".
- K. WALL SLEEVES ARE ONLY REQUIRED WHEN SERVICE PENETRATES CONCRETE OR MASONRY WALL. WALL SLEEVES ARE RECOMMENDED. BUT NOT REQUIRED THROUGH STUCCO OR FRAME CONSTRUCTION.
- L. THE CLASS 400 METERS HAVE 30 LIGHT CONNECTIONS IN NEW YORK CITY AND 45 LIGHT CONNECTIONS IN LONG ISLAND. THE CLASS 630 METER WILL HAVE 45 LIGHT CONNECTIONS IN LI AND NYC. **FOOTNOTE B = BLACK AND G = GALVANIZED**

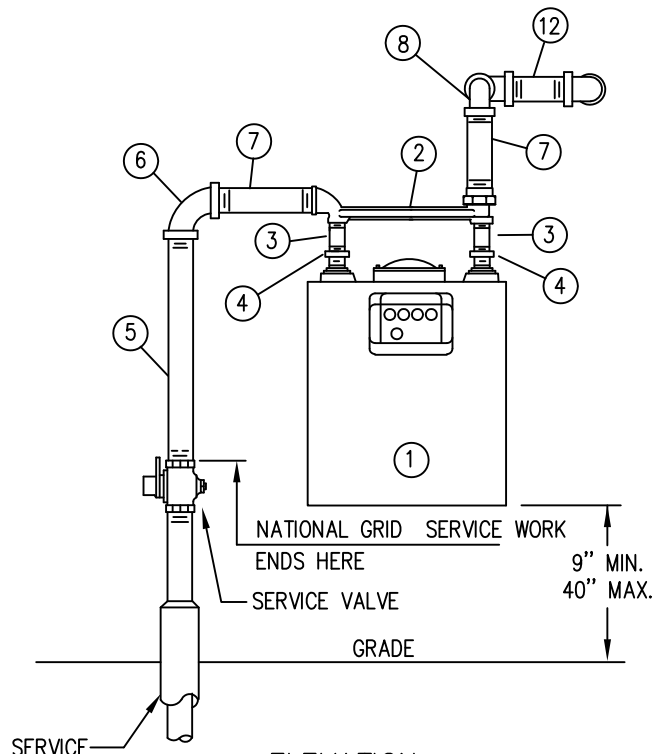
METER CAPACITIES	0 - 250 CFH RANGE	0 - 425 CFH RANGE	0 - 630 CFH RANGE
AMERICAN / ELSTER	AL -250	AL-425	AC-630
ROCKWELL / EQUIMETER/SENSUS	275	415	
SPRAGUE / SCHLUMBERGER/ITRON	250	400	

		250 METER METER SET		400 & 630 METER SET			
18	CPR TAG (LONG ISLAND ONLY)	9340255		9340255		NGG	
17	WALL SLEEVE – PVC PLASTIC PIPE OR STD. WT STEEL PIPE (2" LONGER THAN WALL THICKNESS)	-----		-----		CONTRACTOR	
16	ELBOW 90 DEGREE GALVANIZED	1"	9341181	1-1/4"	9341182	CONTRACTOR	
15	PROTECTION POST (SEE NOTE H)	-----		-----		CONTRACTOR	
14	YARN, PACKING	-----		-----		CONTRACTOR	
13	FLEXIBLE SEALING COMPOUND (DUXSEAL)	-----		-----		CONTRACTOR	
12	HOUSE PIPING TO LOAD	-----		-----		CONTRACTOR	
11	ELBOW ,90 M.I. SIZE OF HOUSE PIPE (GALV.)	1"		1 - 1/4"		CONTRACTOR	
10	NIPPLE 3" MINIMUM GALVANIZED (LENGTH AS REQUIRED)	1"	9340641	1 - 1/4"	9340652	CONTRACTOR	
9	STREET ELBOW, / REDUCING STREET ELBOW 90 M.I. GALVANIZED	1" X 1 - 1/4"	9341199	1 - 1/4"	9341193	CONTRACTOR	
8	NIPPLE 4" MINIMUM GALVANIZED (LENGTH AS REQUIRED)	1 - 1/4"	9340652	1 - 1/4"	9340652	CONTRACTOR	
7	METER VALVE, LOCK WING GALVANIZED	1 - 1/4"	9339609	1 - 1/4"	9339609	CONTRACTOR	
6	VENT ASSEMBLY WITH INSECT RESISTANT SCREEN, IF REQUIRED, 1"	9358640		9358640		NGG	
5	METER CAP / NUT CONNECTION SEE NOTE L	NEW YORK CITY 250 & 400	9340787 <sup>G</sup> 9339519 <sup>B</sup>	1 - 1 / 4" 20LT	9383207 <sup>G</sup> 1-1/4" 30 LT 9339622 <sup>B</sup> 1-1/4" 30 LT	NGG	
		NEW YORK CITY 630 CLASS	-	-	9339623 1-1/4" 45 LT <sup>B</sup> 9340788 1-1/4" 45 LT <sup>G</sup>		
		LONG ISLAND (GALV.)	9340787		1 - 1 / 4" 45 LT		9340788
4	METER, OFFSET SWIVEL SEE NOTE L	NEW YORK CITY 250 & 400	1" 20 LT	9383109 <sup>B</sup> 9342452 <sup>G</sup>	1-1/4" 30 LT.	9342456 <sup>B</sup> 9383108 <sup>G</sup>	NGG
		NEW YORK 630 CLASS	-	-	1-1/4" 45 LT.	9386167 <sup>B</sup> 9342425 <sup>G</sup>	
		LONG ISLAND (GALV.)	1" 20 LT.	9383109	1-1/4" 45 LT.	9342425	
3	REGULATOR, 1 -1/4" ITRON – 42R / B 31 R, SENSUS 143 – 80 –2, AMERICAN 1813 OR SR-100 FOR 15 PSIG SERVICE – REGULATOR, 1 – 1/4" WITH 1/4" ORIFICE FOR 60 PSIG SERVICE- REGULATOR, 1 – 1/4" WITH 3 /16" ORIFICE FOR 99 / 124 PSIG SERVICE – REGULATOR, 1 – 1/4" WITH 1/8" ORIFICE	9342623 9342206 9383127		9342623 9342206 9383127		NGG NGG NGG	
2	METER BAR, W / INSUL. OUTLET, GALV. AY MCD#6610-GCCD OR EQ. METER BAR, W / INSUL. OUTLET, GALV. AY MCD#6640-GCCD OR EQ. METER BAR, W/INSULATED OUTLET, BLACK WITH TOP OUTLET	1" X 1" X1" 9383181 ----- -----		----- 1-1/4" X 1-1/4" 9383209 1-1/4" X 1-1/4" 9339756		NGG	
1	METER (TEMPERATURE COMPENSATED)	0-250		0-425 & 0-630		NGG	
No.	ITEM	250 METER SET NGG CODE NO.		400 & 630 METER SET NGG CODE NO.		NGG CODE No.	

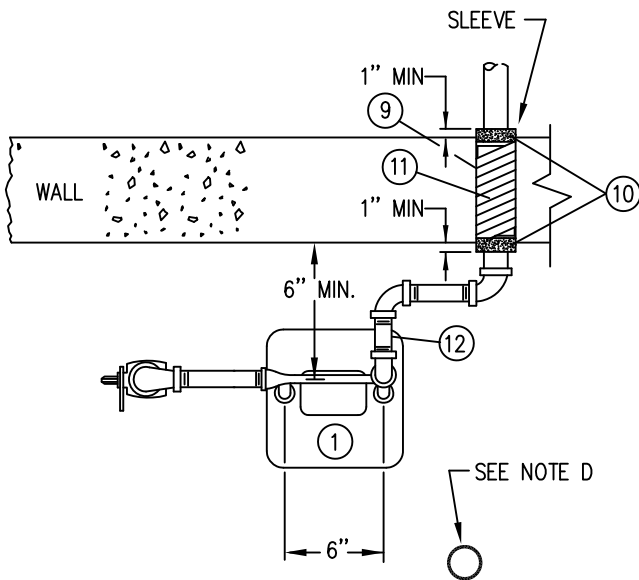
**NOTE: IN NYC, ALL MATERIALS AFTER THE SERVICE VALVE WILL BE FURNISHED AND INSTALLED BY THE CUSTOMER EXCEPT FOR THE REGULATOR WHICH IS FURNISHED BY THE COMPANY AND INSTALLED BY THE CUSTOMER. THE METER, SWIVEL AND CAPS (METER NUTS) WILL BE FURNISHED AND INSTALLED BY THE COMPANY. IN LONG ISLAND,NATIONAL GRID WILL INSTALL UP TO THE METER BAR.**



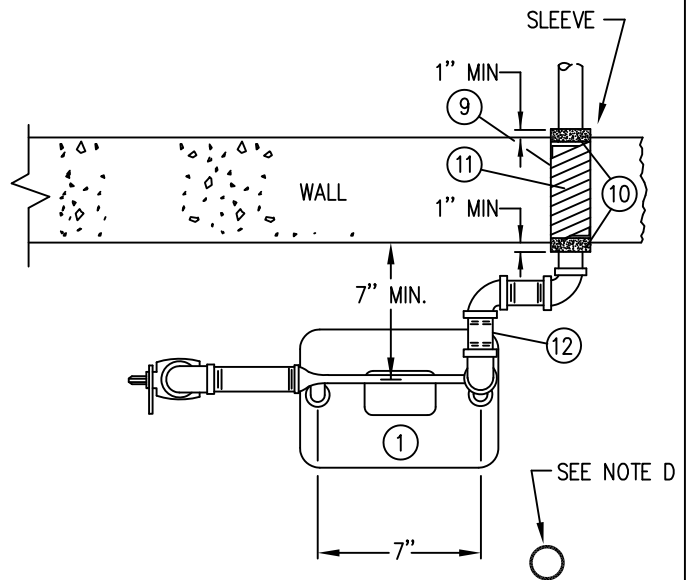
**ELEVATION**  
250 CFH TYPE



**ELEVATION**  
425 CFH TYPE



**PLAN**  
250 CFH TYPE



**PLAN**  
425 CFH TYPE

**nationalgrid**

NEW YORK CITY

**LOW PRESSURE SINGLE METER  
OUTSIDE INSTALLATION  
0 - 250 CFH AND 0 - 425 CFH RANGE**

**Key Changes:** REVISED USING SAP ITEM ID #'S

DATE: 7/1/2003

EFFECTIVE DATE: 09/15/2013

DESIGN: F. TAYLOR/ R. BLOISE

STD. DWG.

DRAWN: J. CASTALUCCI

NO. **MTRS-6150**

**NOTES**

- A. KEY REQUIREMENTS FOR THE CONSTRUCTION OF METER HEADERS AND METER INSTALLATIONS ARE CONTAINED IN SPECIFICATIONS CUST-5235.
- B. ADDITIONAL FITTINGS MAY BE REQUIRED TO MAKE THE METER INSTALLATION.
- C. NATIONAL GRID SHALL NOT BE RESPONSIBLE FOR DIMENSIONS OR FOR SCALED DIMENSIONS.
- D. WHERE VEHICULAR TRAFFIC IS A CONCERN, INSTALL PROTECTION POST SEE MTRS-6060 FOR INSTALLATION REQUIEMENTS.
- E. COAT ALL PIPE AND FITTINGS WITH RUSTOLEUM #7715 OR EQUAL TWO COATS REQUIRED, BRUSH APPLIED.
- F. FOR UNDERGROUND PIPING AFTER METER, CONTACT GAS ENGINEERING FOR NATIONAL GRID REQUIREMENTS.

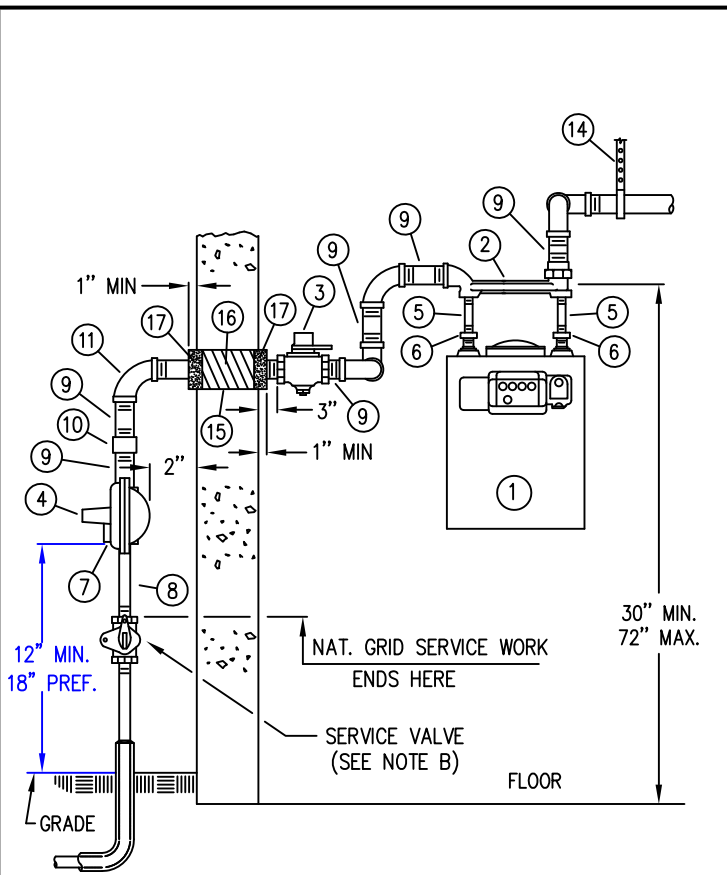
**NOTE: ALL MATERIALS AFTER THE SERVICE VALVE WILL BE FURNISHED AND INSTALLED BY THE CUSTOMER EXCEPT FOR THE REGULATOR WHICH IS FURNISHED BY THE COMPANY AND INSTALLED BY THE CUSTOMER. THE METER, SWIVEL AND CAPS (METER NUTS) WILL BE FURNISHED AND INSTALLED BY THE COMPANY.**

METER CHART		
METER CAPACITIES	0 – 250 CFH RANGE	0 – 425 CFH RANGE
AMERICAN / ELSTER	AL - 250	AL - 425
ROCKWELL EQUIMETER SENSUS	275	415
SPRAGUE /ACTARIS SCHLUMBERGER ITRON	250	400

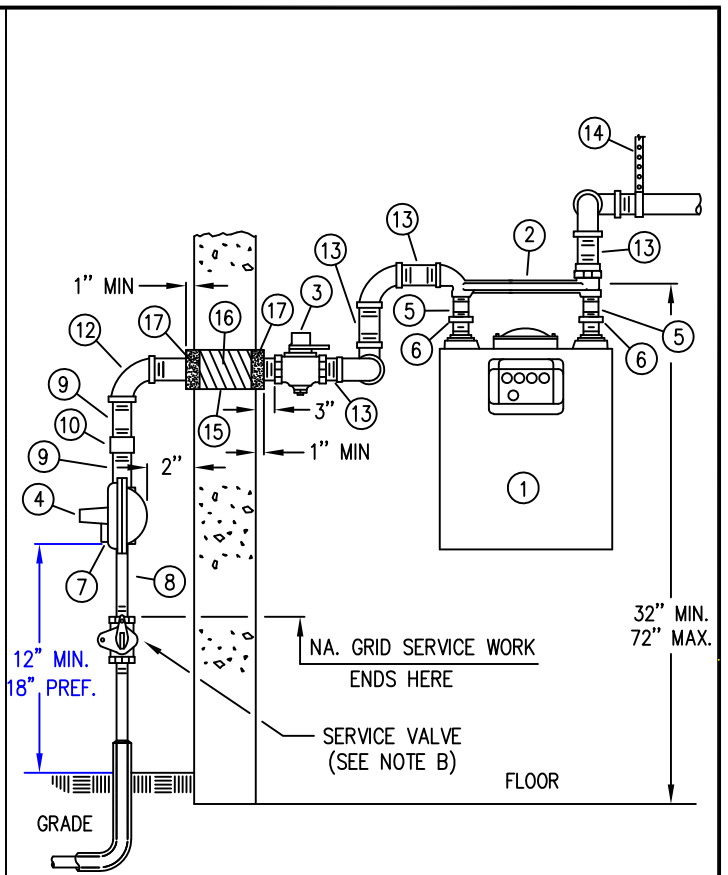
12	HOUSE PIPING TO LOAD	----	----	CONTRACTOR
11	WALL SLEEVES SHALL BE PVC PLASTIC PIPE, OR STANDARD WEIGHT STEEL PIPE (2" LONGER THAN WALL THICKNESS)	----	----	CONTRACTOR
10	FLEXIBLE SEALING COMPOUND (DUXSEAL)	----	----	CONTRACTOR
9	YARN, PACKING	----	----	CONTRACTOR
8	ELBOW, 90 DEGREE M.I. SIZE OF HOUSE PIPE RISER x	1"	1-1/4"	CONTRACTOR
7	NIPPLE 4" MINIMUM (LENGTH AS REQUIRED)	1"	1-1/4"	CONTRACTOR
6	ELBOW, / REDUCING ELBOW 90 M.I.	1"X1-1/4"	1-1/4"	CONTRACTOR
5	NIPPLE 1 1/4" GALVANIZED OR EQUAL (LENGTH AS REQUIRED)	1-1/4"	1-1/4"	CONTRACTOR
4	METER, NUT/CAP CONNECTION OR METER, NUT/CAP CONNECTION GALVANIZED	9339504 20 LT 9340787 20 LT	9339622 30 LT 9383207 30 LT	NG
3	METER, OFFSET SWIVEL OR METER, OFFSET SWIVEL GALVANIZED	9342452 20LT 9383109 20LT	9342450 30 LT 9383108 30 LT	NG
2	METER BAR, WITH INSULATED OUTLET TOP OUT OR METER BAR, WITH INSULATED OUTLET SIDE OUT - GALVANIZED	9339755 9383181	9339756 9383209	NG
1	METER (TEMPERATURE COMPENSATED)	0 - 250	0 - 425	NG

No.	ITEM	NATL GRID CODE No.		
-----	------	--------------------	--	--

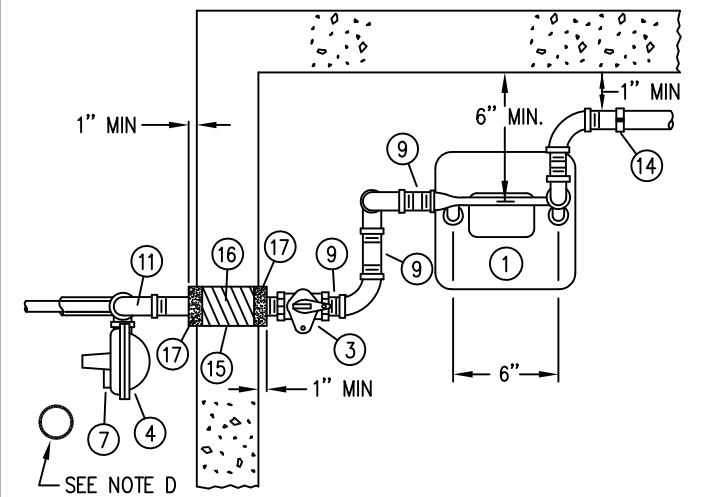
**BILL OF MATERIAL**



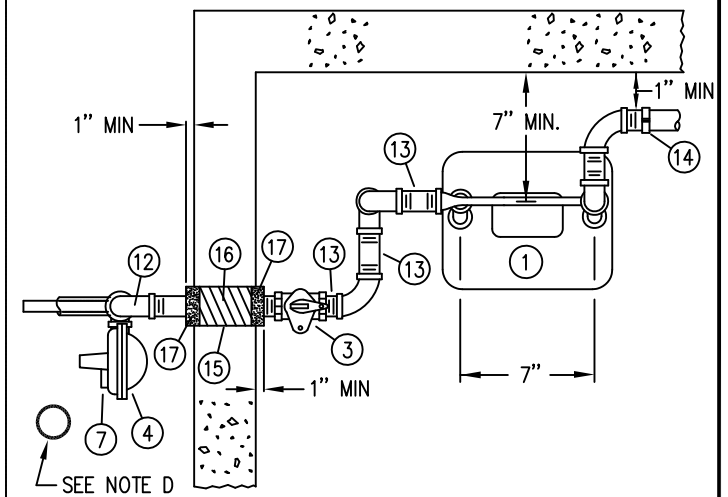
ELEVATION  
250 CFH TYPE



ELEVATION  
425 CFH TYPE



PLAN  
250 CFH TYPE



PLAN  
425 CFH TYPE

**nationalgrid**

NEW YORK CITY

**SINGLE INSIDE METER INSTALLATION WITH  
OUTSIDE REGULATOR 60# H.P. SERVICE  
0 - 250 CFH AND 0 - 425 CFH RANGE**

REVISIONS: **REVISED USING SAP ITEM ID #S**

DATE: 07/01/2003	EFFECTIVE DATE: 09/15/2013
DESIGN: R. BLOISE	STD. DWG.
DRAWN: P. O'NEIL	NO. <b>MTRS-6170</b>



**NOTES**

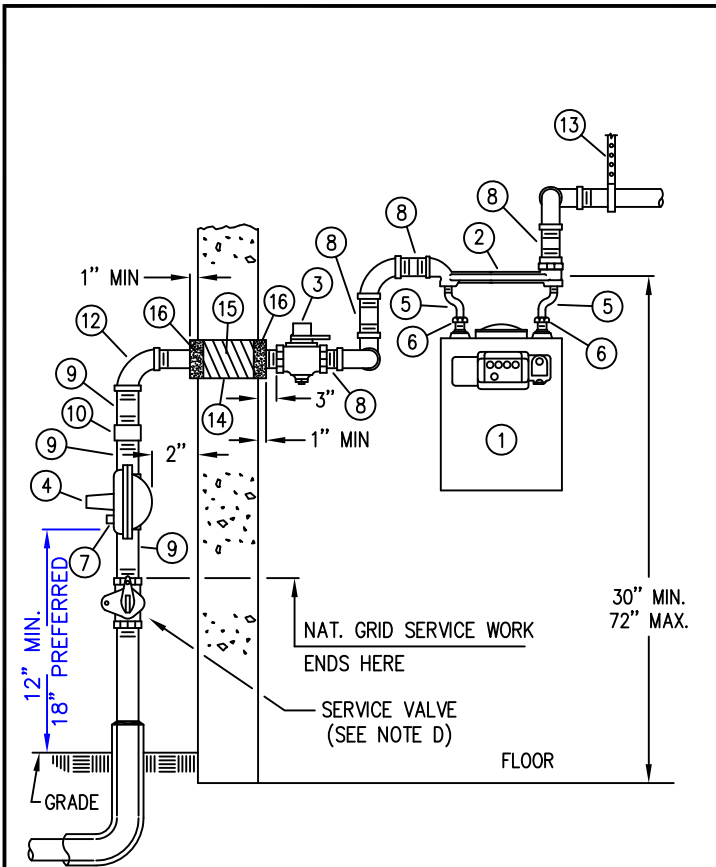
- A. ADDITIONAL FITTINGS MAY BE REQUIRED TO MAKE THE METER AND REGULATOR INSTALLATION.
- B. CURB VALVE IS NOT REQUIRED PROVIDED THERE IS AN ACCESSIBLE OUTSIDE SHUT-OFF VALVE.
- C. COAT ALL OUTSIDE PIPE AND FITTINGS WITH RUSTOLEUM #7715 OR EQUAL. TWO COATS REQUIRED, BRUSH APPLIED. ALSO SERVICE VALVE MUST BE PAINTED RED.
- D. WHERE VEHICULAR TRAFFIC IS A CONCERN, INSTALL DEADMEN. SEE APPROVED VEHICLE PROTECTION SPECIFICATION MTRS-6060
- E. IT IS PREFERRED THAT REGULATOR VENTS BE INSTALLED AT A HEIGHT 18 INCHES ABOVE GRADE, HOWEVER, THE MINIMUM ALLOWABLE VENT HEIGHT SHALL BE 12 INCHES ABOVE FINAL GRADE. IN CASES OF KNOWN FLOOD LOCATIONS, THE PREFERRED REGULATOR VENT HEIGHT ABOVE THE FLOOD HEIGHT IS 18" (12" MINIMUM). THE REGULATOR VENT SHALL BE 18" (WHERE PRACTICAL) FROM ANY OPENING WHICH COULD ALLOW VENTED GAS TO ENTER.
- F. FOR FLOW RATES GRATER THAN 940 CFH (60 PSIG SYSTEM) OR 1,550 CFH (15 PSIG SYSTEM) SEE SPECIAL ENGINEERING METER AND REGULATOR LAYOUT.
- G. NATIONAL GRID SHALL NOT BE RESPONSIBLE FOR FITTING DIMENSIONS OR SCALED DIMENSIONS.

METER CHART		
METER CAPACITIES	0-250 CFH RANGE	0-425 CFH RANGE
AMERICAN	AL-250	AL-425
ROCKWELL EQUIMETER SENSUS	275	415
SPRAUE SCHLUMBERGER ACTARIS / ITRON	250	400

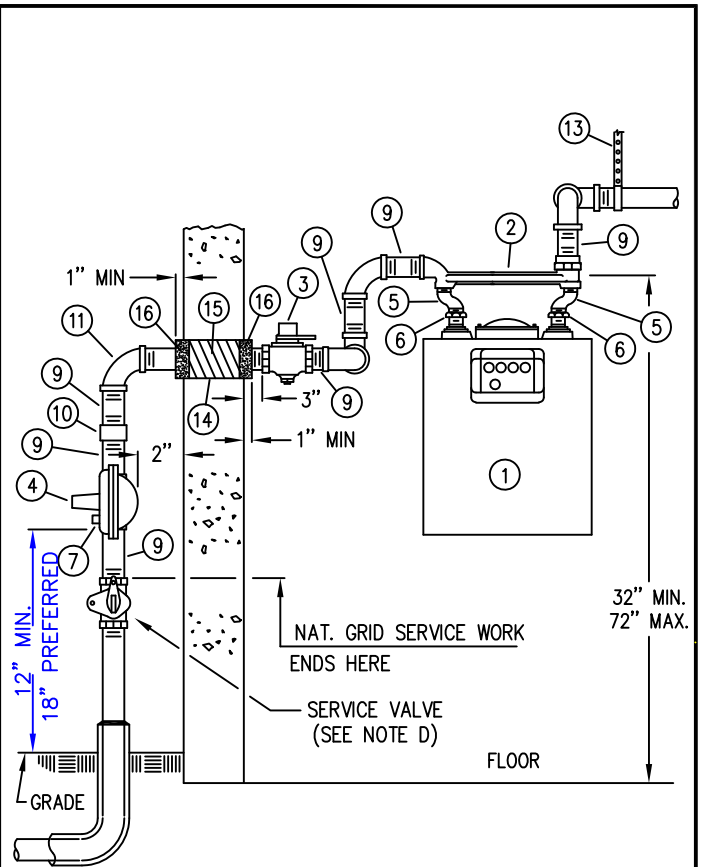
No.	ITEM				
17	FLEXIBLE SEALING COMPOUND (DUXSEAL)	----	----	CONTRACTOR	
16	YARN, PACKING	----	----	CONTRACTOR	
15	WALL SLEEVE, PVC PLASTIC OR STANDARD WEIGHT STEEL (2" LONGER THAN THICKNESS)	1- 1/2"	2"	CONTRACTOR	
14	PIPE SUPPORT / STRAPPING (NEOPRENE OR EQUAL BETWEEN THE SUPPORT AND THE PIPE)	----	----	CONTRACTOR	
13	NIPPLE 4" MINIMUM (LENGTH AS REQUIRED)	----	1- 1/4"	CONTRACTOR	
12	ELBOW, REDUCING 90 M.I.	----	1-1/4" X 1"	CONTRACTOR	
11	ELBOW, 90 M.I.	1"	----	CONTRACTOR	
10	UNION, STEEL, SCREW, INSULATING, 150#	1"	1"	CONTRACTOR	
9	NIPPLE 4" MINIMUM (LENGTH AS REQUIRED)	1"	1"	CONTRACTOR	
8	NIPPLE 4" MINIMUM (LENGTH AS REQUIRED)	3/4"	3/4"	CONTRACTOR	
7	VENT ASSEMBLY WITH SCREEN, IF REQUIRED (SEE NOTE E)	1"	9358640	9358640	CONTRACTOR
6	METER, CAP / NUT CONNECTION OR METER, CAP / NUT CONNECTION GALVANIZED		9339504 20 LT 9340787 20 LT	9339622 30 LT 9383207 30 LT	NGG
5	METER, OFFSET SWIVEL OR METER, OFFSET SWIVEL - GALVANIZED		9342452 20 LT 9383109 20 LT	9342450 30 LT 9383108 30 LT	NGG
4	REGULATOR, FISHER HSR , AMEREICAN 1813B2 OR SR-100, ITRON B31R OR B42R - 3/4" X 1" (1/8" ORIFICE), 1" VENT OUTLET OR APPROVED EQUAL		9383047	9383047	NGG
3	COCK, MUELLER, LOCK WING, TAMPER PROOF, H-11118 OR APPROVED EQUAL	1" 1-1/4"	9339611 ---	9339699	NGG
2	METER BAR, WITH INSULATED OUTLET TOP OUT OR METER BAR, WITH INSULATED OUTLET SIDE OUT GALVANIZED		9339755 9383181	9339756 9383209	NGG
1	METER		250	425	NGG
<b>No.</b>	<b>ITEM</b>				

**NOTE: ALL MATERIALS AFTER THE SERVICE VALVE WILL BE FURNISHED AND INSTALLED BY THE CUSTOMER EXCEPT FOR THE REGULATOR WHICH IS FURNISHED BY THE COMPANY AND INSTALLED BY THE CUSTOMER. THE METER, SWIVEL AND CAPS (METER NUTS) WILL BE FURNISHED AND INSTALLED BY THE COMPANY.**

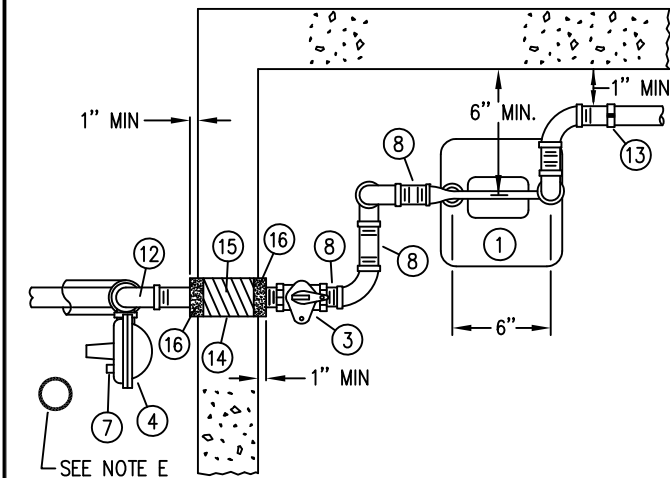




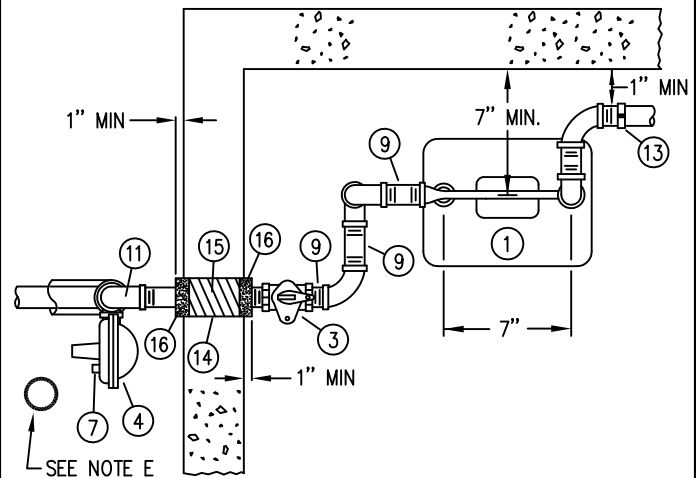
ELEVATION  
250 CFH TYPE



ELEVATION  
425 CFH TYPE



PLAN  
250 CFH TYPE



PLAN  
425 CFH TYPE

**nationalgrid**

NEW YORK CITY

**SINGLE INSIDE METER INSTALLATION WITH  
OUTSIDE REGULATOR 0 - 250 CFH AND  
0 - 425 CFH RANGE 15# H.P. SERVICE**

REVISIONS: REVISED USING SAP ITEM ID #'S

DATE: 07/01/2003

EFFECTIVE DATE: 09/15/2013

DESIGN: R. BLOISE

STD. DWG.

DRAWN: P. O'NEIL

NO. **MTRS-6180**

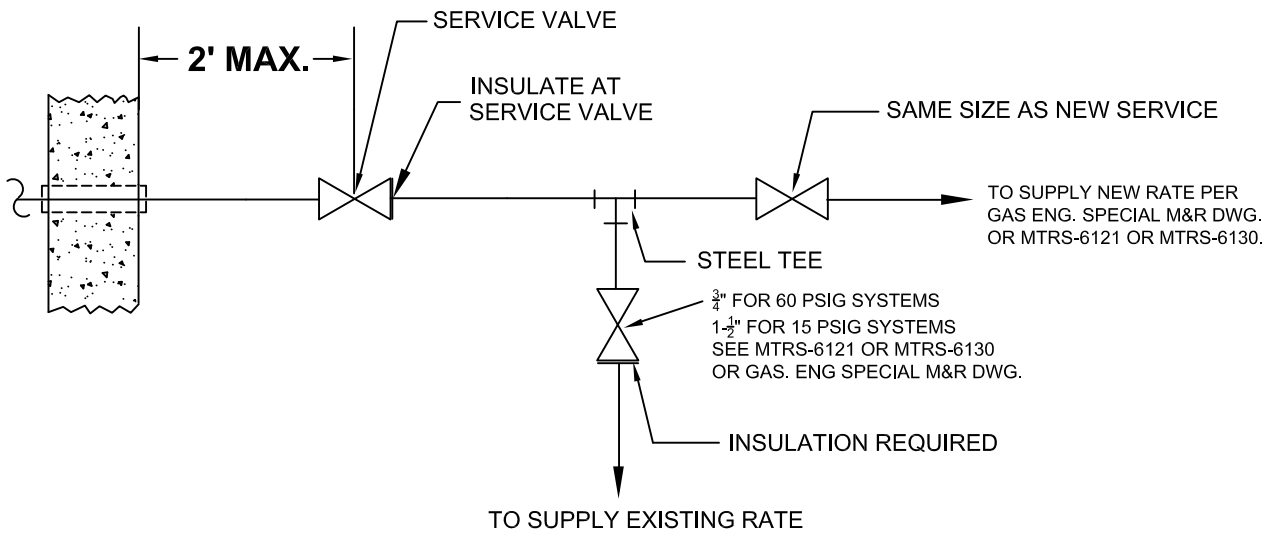
**NOTES**

- A. KEY REQUIREMENTS FOR THE CONSTRUCTION OF METER HEADERS AND METER INSTALLATION IN NATIONAL GRID SPECIFICATIONS CUST-5235.
- B. ADDITIONAL FITTINGS MAY BE REQUIRED TO MAKE THE METER AND REGULATOR INSTALLATION.
- C. CURB VALVE IS NOT REQUIRED PROVIDED THERE IS AN ACCESIBLE OUTSIDE SHUT-OFF VALVE.
- D. COAT ALL OUTSIDE PIPE AND FITTINGS W RUSTOLEUM #7715 OR EQUAL. TWO COATS REQUIRED, BRUSH APPLIED, ALSO SERVICE VALVE MUST BE PAINTED RED.
- E. WHERE VEHICULAR TRAFFIC IS A CONCERN, INSTALL PROTECTION POSTS. SEE MTRS-6060 FOR INSTALLATION REQUIREMENTS.
- F. REGULATOR VENT MUST FACE DOWN AND BE EQUIPPED WITH A RAIN AND INSECT RESISTANT SCREEN. **IT IS PREFERRED THAT REGULATOR VENTS BE INSTALLED AT A HEIGHT 18 INCHES ABOVE GRADE, HOWEVER, THE MINIMUM ALLOWABLE VENT HEIGHT SHALL BE 12 INCHES ABOVE FINAL GRADE. IN CASES OF KNOWN FLOOD LOCATIONS, THE PREFERRED REGULATOR VENT HEIGHT ABOVE THE FLOOD HEIGHT IS 18" (12" MINIMUM). THE REGULATOR VENT SHALL BE 18" (WHERE PRACTICAL) FROM ANY OPENING WHICH COULD ALLOW VENTED GAS TO ENTER.**
- G. FOR FLOW RATES BETWEEN 470 CFH AND 940 CFH (60PSIG SYS) AND 775 CFH AND 1,550 CFH (15 PGIG SYSTEM) SEE MTRS-6120, MTRS-6121 AND MTRS-6130
- H. FOR FLOW RATES GREATER THGAN 940 CFH (60 PSIG SYS) OR 1,550 CFH (15 PSIG SYS) SEE SPECIAL ENGINEERING METER AND LAYOUT.
- I. NATIONAL GRID SHALL NOT BE RESPONSIBLE FOR FITTING OR SCALED DIMENSIONS...

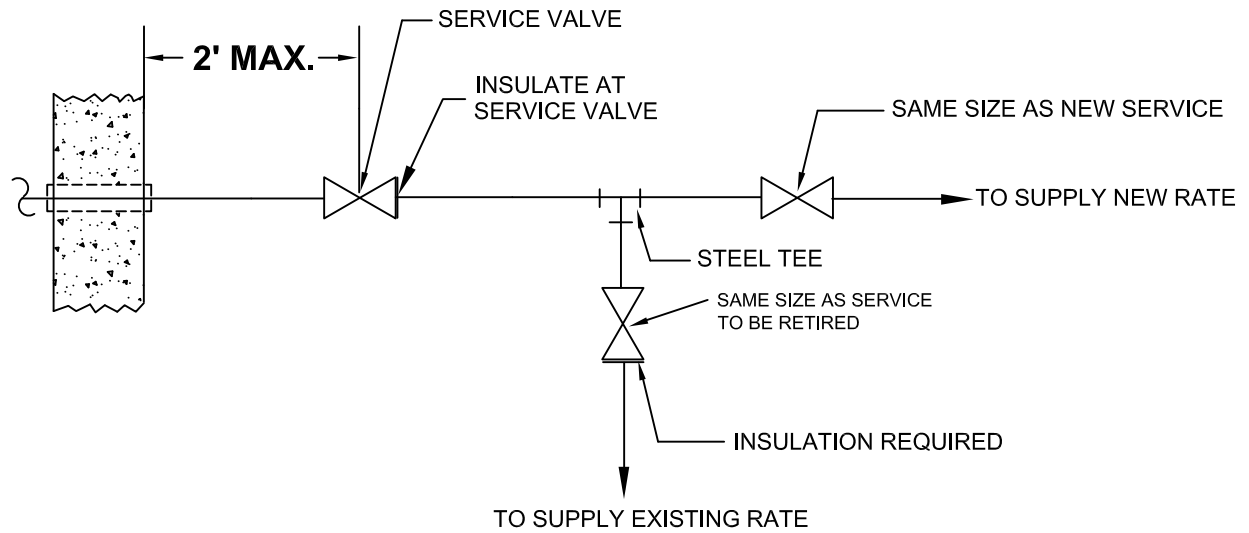
**METER CHART**

METER CAPACITIES		0 -250 CFH RANGE	0 - 425 CFH RANGE	
AMERICAN / ELSTER		AL-250	AL - 425	
ROCKWELL / EQUIMETER / SENSUS		275	415	
SPRAGUE / SCHLUMBERGER / ACTARIS / IRTON		250	400	
1	METER	250	425	NATIONAL GRID
2	METER BAR, WITH INSULATED OUTLET TOP OUTLET METER BAR, WITH INSULATED OUTLET SIDE OUTLET GFLAVANIZED	9339755 9383181	9339756 9383209	NATIONAL GRID
3	COCK, MUELLER, LOCKWING, TAMPER PROOF, H-11118 OR APP. EQUAL 1" 1-1/4"	9339611 ---	--- 9339699	NATIONAL GRID
4	REGULATOR, FISHER S-102K / ACTARIS B31 / AMERICAN 1813B2 OR APP. EQUAL - 1-1/4" X1-1/4" (1/4" ORIFICE) WITH 1" VENT (15 PSIG MAX.)	9342623	9342623	NATIONAL GRID
5	METER OFFSET SWIVEL OR METER OFFSET SWIVEL GALVANIZED	9342452 20LT 9383109 20LT	9342450 30LT 9383108 30LT	NATIONAL GRID
6	METER, CAP / NUT CONNECTION OR METER CAP / NUT COMNNECTION GALVANIZED	9339504 20LT 9340787 20 LT	9339622 30LT 9383207 30 LT	NATIONAL GRID
7	VENT ASSEMBLY W/ SCREEN 1" (SEE NOTE F)	9358640	9358640	CONTR
8	NIPPLE, 4" MINIMUM ( IF REQUIRED)	1"	1-1/4"	CONTR
9	NIPPLE 4" MINIMUM ( LENGTH AS REQUIRED)	1-1/4"	1-1/4"	CONTR
10	UNION, STEEL, SCREW, INSULATING, 150#	1-1/4"	1-1/4"	CONTR
11	ELBOW, 90 M.I.	1"	1-1/4"	CONTR
12	ELBOW, REDUCING, 90 M.I.	1-1/4" X1"	-----	CONTR
13	PIPING SUPPORT / STRAPPING (NEOPRENE OR EQUAL BETWEEN THE SUPPORT AND PIPE)	-----	-----	CONTR
14	WALL SLEEVE ( 2" LONGER THAN WALL THICKNESS)	1-1/2"	2"	CONTR
15	YARN , PACKING	-----	-----	CONTR
16	FLEXIBLE SEALING COMPOUND ( DUXSEAL)	-----	-----	CONTR
17	PROTECTION POST, FOR SERVICE & REGULATOR PROTECTION (SEE NOTE E)	-----	-----	CONTR
<p><b>NOTE: ALL MATERIALS AFTER THE SERVICE VALVE WILL BE FURNISHED AND INSTALLED BY THE CUSTOMER EXCEPT FOR THE REGULATOR WHICH IS FURNISHED BY THE COMPANY AND INSTALLED BY THE CUSTOMER. THE METER, SWIVEL AND CAPS (METER NUTS) WILL BE FURNISHED AND INSTALLED BY THE COMPANY.</b></p>				NAT. GRID CODE

**BILL OF MATERIAL**



H.P. INSTALLATIONS



L.P. INSTALLATIONS


**BASEMENT TEE INSTALLATION POLICY:**

GAS MAINTAIN / CONSTRUCTION TO INSTALL BASEMENT TEE ON L.P. SERVICE RELAYS WHERE GAS MAINTAIN / CONSTRUCTION RECONNECTS HEADER PIPING. IN ALL OTHER INSTALLATIONS, CUSTOMER SERVICE DEPT. OR PLUMBER TO INSTALL BASEMENT TEE.

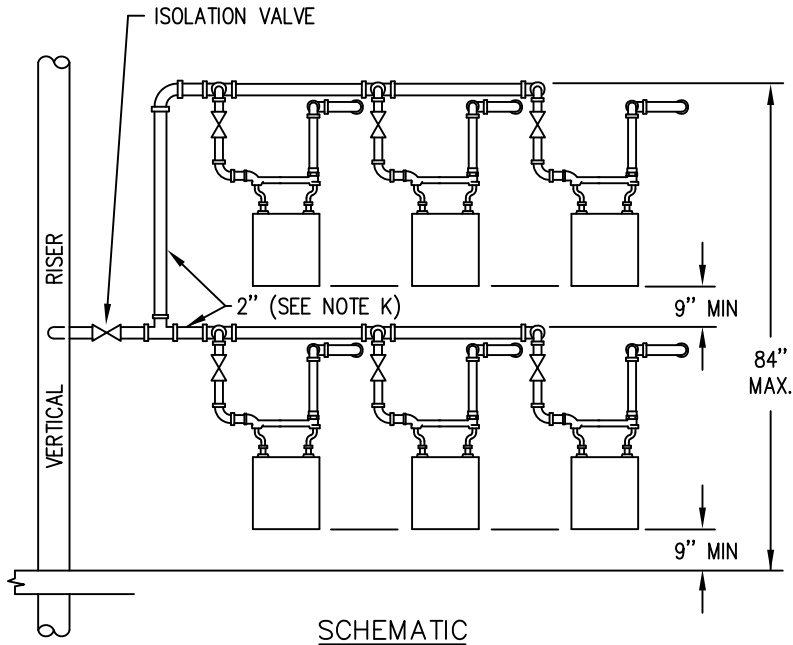
**NOTE:**

THE MAXIMUM DISTANCE FROM THE CENTER OF THE SERVICE VALVE TO THE REGULATOR SHALL BE LIMITED AS FOLLOWS: SEE TABLE BELOW:

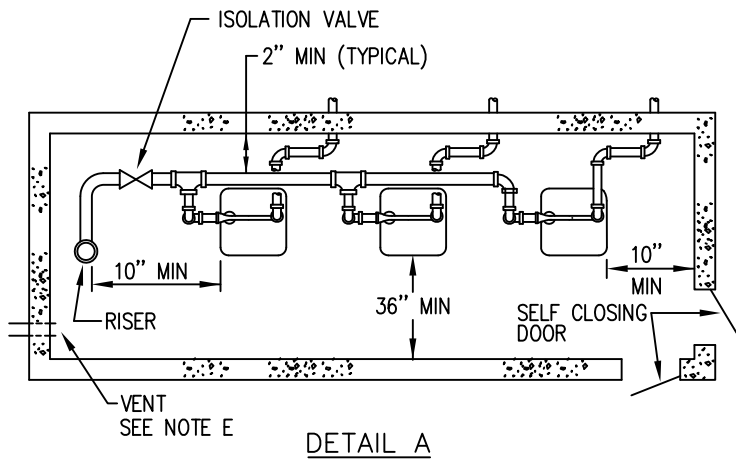
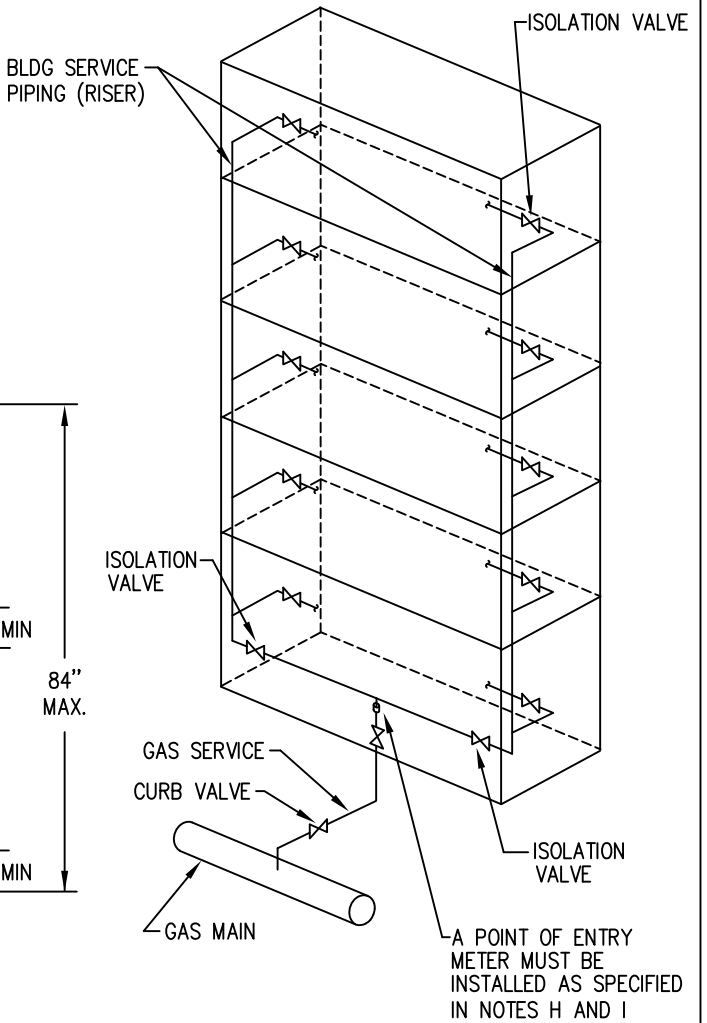
SERVICE VALVE	MAX. DISTANCE (LINEAR FEET)
UP THROUGH 2" PIPE	4 FEET
OVER 2" THROUGH 4" PIPE	8 FEET
OVER 4" THROUGH 8" PIPE	15 FEET

 LONG ISLAND	<b>RECOMMENDED HP &amp; LP          METER PIPING INSTALLATIONS FOR          MULTIPLE RATE INSTALLATIONS</b>	
	DATE: 07/01/2003 DESIGN: R. CURRY DRAWN: J. CASTALUCCI/P. GUGLIOTTA	EFFECTIVE DATE: 07/01/2003 STD. DWG. NO. <b>MTRS-6190</b>
<b>REVISIONS:</b> NEW STANDARD REPLACED CS-25		

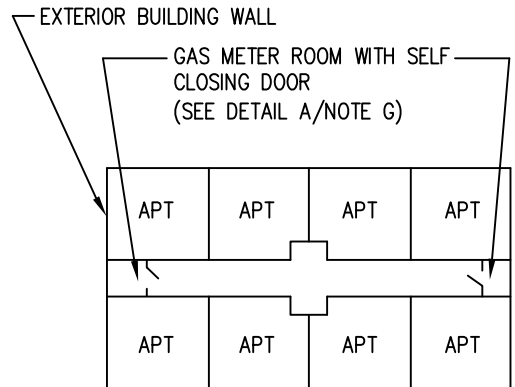
NOT FOR NEW CONSTRUCTION  
(SEE NOTE A)



SCHEMATIC



DETAIL A



PLAN VIEW

**nationalgrid**

NEW YORK CITY

**TYPICAL METER SET ON  
INDIVIDUAL BUILDING FLOORS**

**KEY CHANGES:** REDRAWN AND REPLACES CS-35

DATE: 07/01/2003

EFFECTIVE DATE: 07/01/2003

DESIGN: F. TAYLOR

STD. DWG.

DRAWN: J. CASTALUCCI

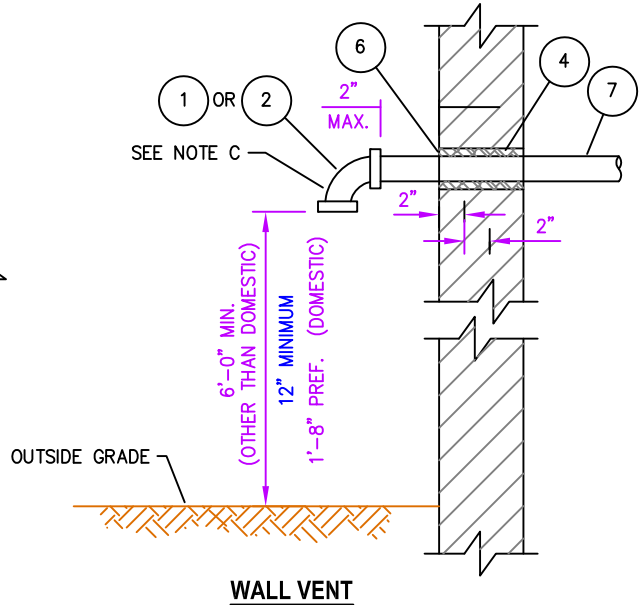
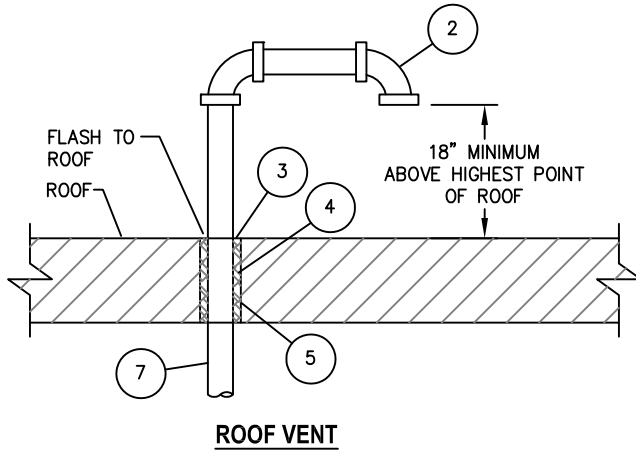
NO. **MTRS-6200**

## NOTES

- A. FLOOR SETS MAY BE INSTALLED FOR RENOVATION WORK, NOT NEW CONSTRUCTION. DESIGN AND CONSTRUCTION OF FLOOR SETS MUST HAVE PRIOR APPROVAL FROM ENGINEERING.
- B. KEY REQUIREMENTS FOR THE CONSTRUCTION OF HEADERS AND METER INSTALLATION ARE CONTAINED IN STANDARD CUST-5235.
- C. METER SHALL BE LOCATED ADJACENT TO VERTICAL RISER.
- D. ALL BRANCHES OFF VERTICAL RISERS SHALL HAVE A PLUG VALVE CAPABLE OF ISOLATING THAT BRANCH FROM THE VERTICAL RISER.
- E. EACH METER SHALL BE PROPERLY VENTED TO THE OUTDOORS.
- F. METERS SHALL BE ACCESSIBLE TO KED PERSONNEL.
- G. METER ROOMS SHALL BE EQUIPPED WITH A SELF CLOSING DOOR AND KEPT LOCKED AT ALL TIMES, WITH A KEY FOR OR DUAL LOCK FOR KED AND BUILDING PERSONNEL.
- H. POINT OF ENTRY METER MAY BE ELIMINATED WITH WRITTEN APPROVAL OF N.Y.C. BUILDING DEPT.
- I. THE POINT OF ENTRY METERS INSTALLED IN THE BASEMENT SHALL NOT BE USED FOR BILLING PURPOSES. (THIS ALSO APPLIES IF THE METER IS INSTALLED OUTSIDE).
- J. METER ROOM MUST BE EQUIPPED WITH EXPLOSION PROOF LIGHTING, FOR GAS PRESSURES ABOVE 15 PSIG. CONSULT WITH GAS ENGINEERING TO DISCUSS POSSIBLE FUTURE UP-GRADING IN AREA.
- K. IF MORE THAN 3 METERS ARE REQUIRED ON ANY SINGLE BRANCH HEADER, CONTACT GAS ENGINEERING
- L. METER ROOM INSTALLATIONS MUST COMPLY WITH N.Y.C ADMINISTRATION CODE TITLE 27 AND RS – 16 SECTION P115.0 AND MUST BE LARGE ENOUGH TO WORK WITH THE DOORS CLOSED.
- M. FOR HIGH PRESSURE INSTALLATIONS, SEE APPROPRIATE ENGINEERING METER AND REGULATOR DRAWINGS, FOR LOW PRESSURE INSTALLATIONS, SEE APPROPRIATE LOW PRESSURE METER STANDARD DRAWING REGULATORS AND / OR POINT OF ENTRY METER SHOULD BE INSTALLED AS CLOSE AS PRACTICABLE TO THE GAS SERVICE POINT OF ENTRY INTO THE BUILDING IF AN OUTSIDE INSTALLATION IS PRESCRIBED, THE REGULATOR AND / OR METER SHOULD BE INSTALLED DOWNSTREAM OF THE SERVICE VALVE AND AS CLOSE AS PRACTICABLE TO THE GAS PIPING POINT OF ENTRY INTO THE BLDG.
- N. IF ANY OF THE REQUIREMENTS STIPULATED WITHIN THIS STANDARD CANNOT BE MET , APPROVAL MUST BE OBTAINED FROM THE GAS ENGINEERING
- O. PIPING FROM THE OUTLET OF THE POINT OF ENTRY METER ASSEMBLY (OR THE SERVICE VALVE AT THE POINT OF ENTRY IF THERE IS NO POINT OF ENTRY METER) TO THE ISOLATION VALVE IN EACH METER ROOM SHALL BE CONSIDERED PART OF THE HOUSE DISTRIBUTION PIPING.

**NOTES**

- A. COAT OUTSIDE VENT ASSEMBLY WITH ROYSTON No. 9421 ROYLAC ALUMINUM FINISH COAT.
- B. FOR DETAILS OF ROOF VENTS LARGER THAN 2", CONSULT THE ENGINEERING AREA.
- C. VENT ASSEMBLY TO BE A MINIMUM OF 18" FROM ANY OPENING WHICH COULD ALLOW VENTED GAS TO ENTER THE BUILDING. IF THIS MINIMUM DISTANCE IS NOT PRACTICAL OBTAIN APPROVAL FROM ZONE MANAGER OF CUSTOMER SERVICE OR ENGINEERING AREA PRIOR TO INSTALLATION.



7	VENT HEADER		-
6	GROUT OR FLASHING		-
5	PIPE SLEEVE		-
4	YARN PACKING		9353980
3	SEALING COMPOUND		9330862
2	M.I. ELBOW, WITH RAIN & INSECT RESISTANT SCREEN	1" 1-1/4" 1-1/2" 2"	9341251 9341250 9341224 9341281
1	VENT ASSEMBLY, WITH RAIN & INSECT RESISTANT SCREEN	3/4" 1" 1-1/4" 1-1/2" 2"	9358637 9358640 9358638 9358641 9358636
<b>NO.</b>	<b>ITEM</b>		<b>ITEM ID</b>

**BILL OF MATERIAL**

**nationalgrid**

NEW YORK CITY

**VENT ASSEMBLY DETAILS**

**Key Changes:** REVISED USING SAP ITEM ID #'S

DATE: 07/01/2003

EFFECTIVE DATE: 07/15/2013

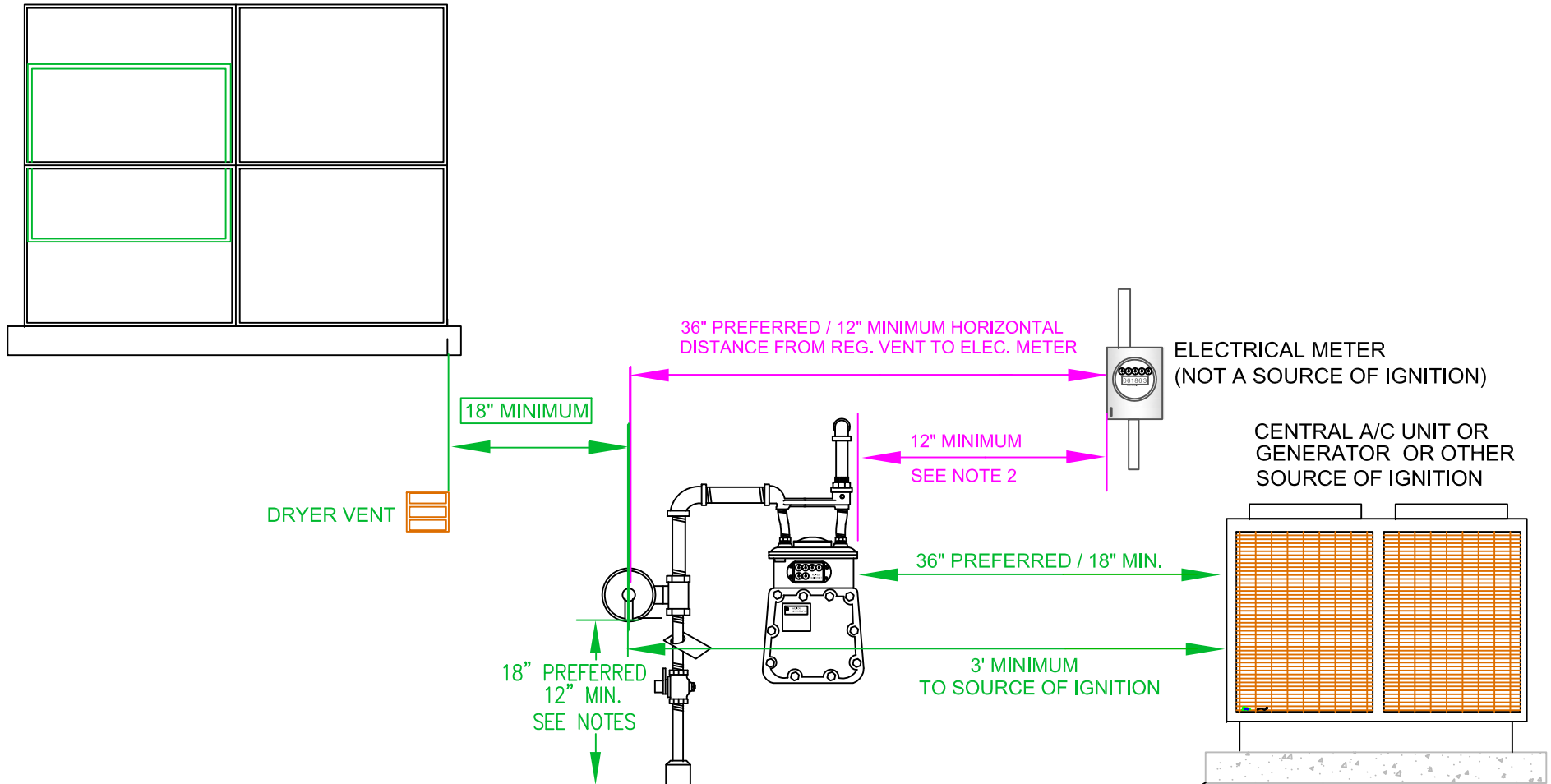
DESIGN: WC


STD. DWG.

DRAWN: RWC / P. DIMAIO

NO. **MTRS-6220**

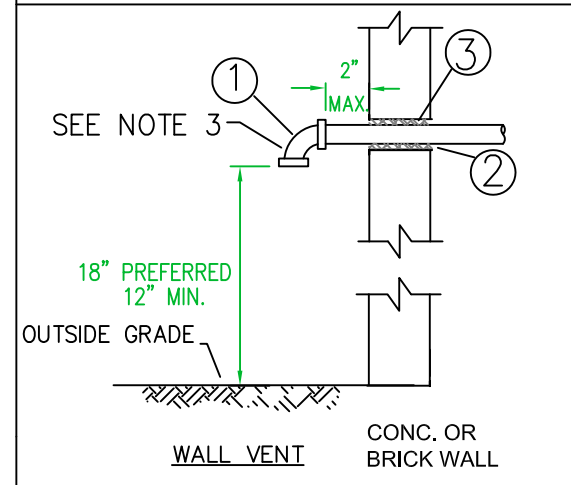
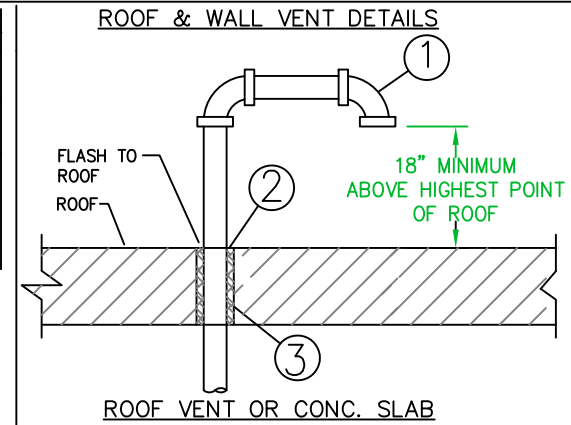
# PREFERRED INSTALLATIONS:



 <p>ALL REGIONS</p>	<p>OUTDOOR LOCATION FOR REGULATOR AND RELIEF VALVE VENT TERMINUS</p>	
	<p>DATE: 07/15/2010</p> <p>DESIGN: PAUL GUGLIOTTA</p> <p>DRAWN: PAUL GUGLIOTTA</p>	<p>EFFECTIVE DATE: 12/15/2015</p> <p>STD. DWG. NO. 020013-CS</p>
<p>Key Changes: REVISED CLEARANCES TO ELECTRIC METER AND WINDOWS</p>		

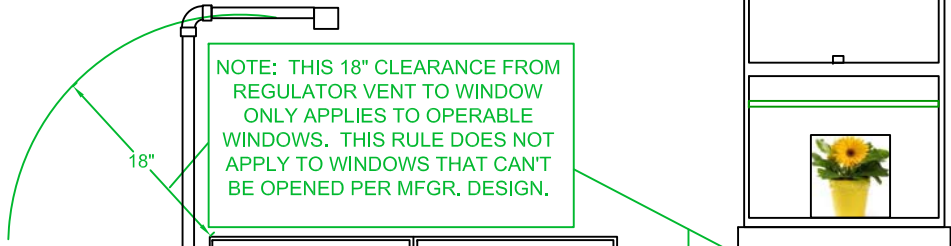
**GUIDELINES FOR NON-PREFERRED INSTALLATIONS:**

#	ITEM	SIZE	ITEM ID	
			LI/NYC/MA	UNY / RI
3	PIPE SLEEVE		---	---
2	SEALING COMPOUND		9330862	NON STOCK
1	VENT ASSEMBLY, WITH RAIN & INSECT RESISTANT SCREEN	3/4"	9358637	NON STOCK
		1"	9358640	9315859
		1-1/4"	9358638	NON STOCK
		1-1/2"	9358641	NON STOCK
		2"	9358636	9310355



**SERVICE REGULATOR VENT RESTRICTIONS**

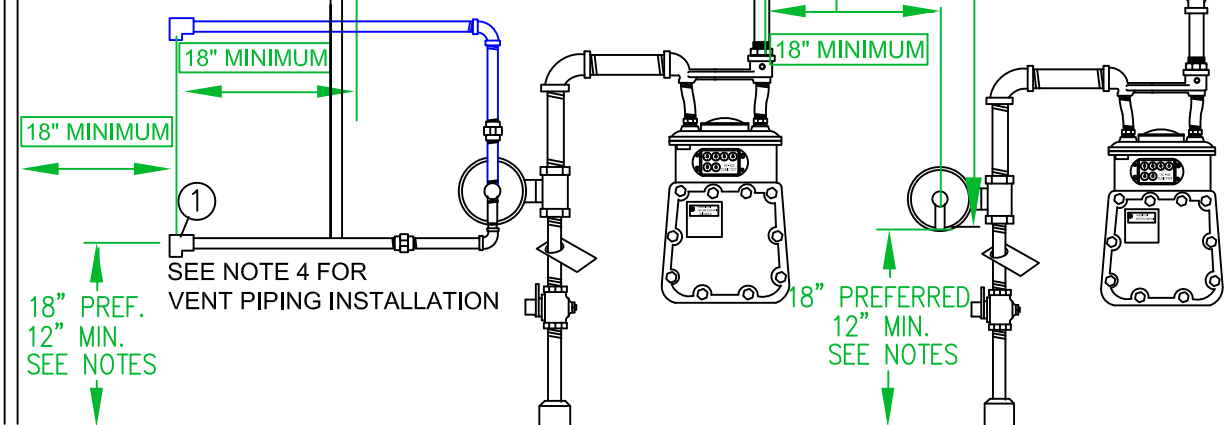
NOTE: THIS 18" CLEARANCE FROM REGULATOR VENT TO WINDOW ONLY APPLIES TO OPERABLE WINDOWS. THIS RULE DOES NOT APPLY TO WINDOWS THAT CAN'T BE OPENED PER MFGR. DESIGN.



6' MINIMUM VERTICAL CLEARANCE FROM WINDOW

METER SETS LOCATED UNDER THE WINDOW SHOULD BE AVOIDED

SEE NOTE 7 FOR VENTING PIPING FACING UP

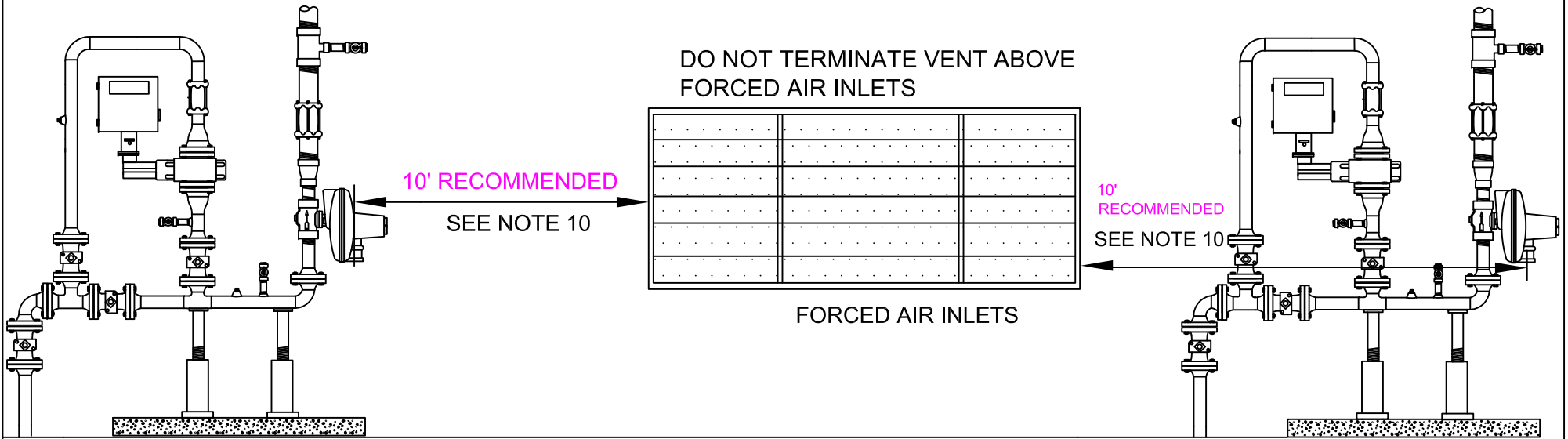


18" PREFERRED 12" MIN. SEE NOTES

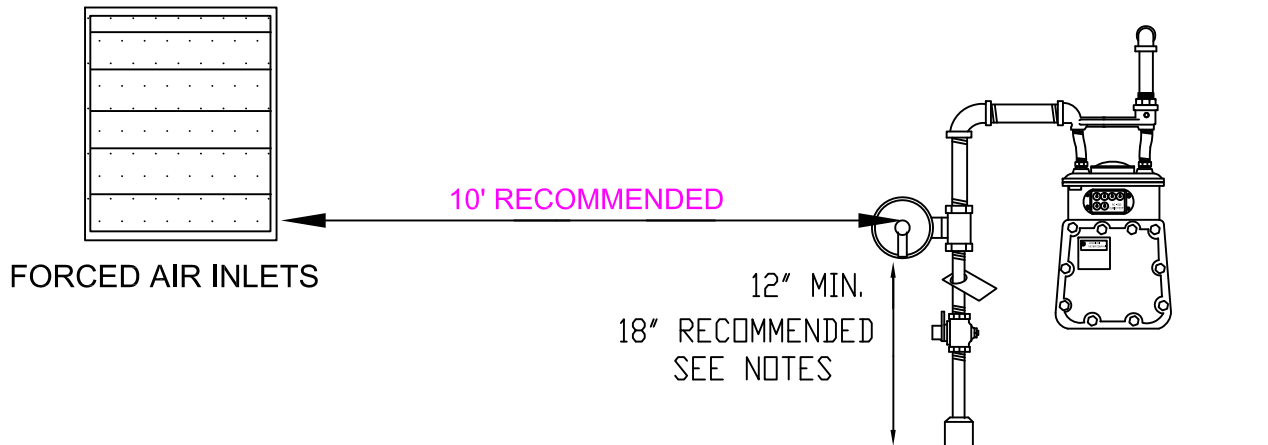
18" PREFERRED 12" MIN. SEE NOTES



LARGE COMMERCIAL & INDUSTRIAL INSTALLATIONS



DO NOT TERMINATE VENT ABOVE FORCED AIR INLETS



**NOTES:**

1. A REGULATOR VENT CANNOT BE LOCATED UNDER AN OVERHANG THAT CAN TRAP GAS SUCH AS A PITCHED AWNING WITH SIDES. A VENT MAY BE LOCATED UNDER A FLAT SURFACE HORIZONTAL OVERHANG UNDER 6' IN LENGTH AS LONG AS THE OVERHANG HAS NO OPENINGS INTO THE BUILDING WITHIN 18 INCHES OF THE VENT TERMINUS.
  2. **A GAS METER** MUST HAVE A MINIMUM OF 12" HORIZONTAL CLEARANCE DISTANCE FROM A STANDARD ELECTRIC METER.
  3. **THE GAS REGULATOR** VENT TERMINUS MUST:
    - HAVE A MINIMUM CLEARANCE OF 36" PREFERRED / 12" MINIMUM HORIZONTAL DISTANCE FROM A STANDARD ELECTRIC METER. IF THE REGULATOR IS WITHIN 36" OF THE ELECTRIC METER, THE VENT SHOULD BE PIPED AWAY FROM THE ELECTRIC METER.
- NOTE: VENTLESS AND VENT LIMITING REGULATORS DO NOT APPLY TO THE FOLLOWING GUIDELINES AND THERE IS NO MINIMUM DISTANCES ESTABLISHED FOR VENT LIMITING AND VENTLESS REGULATORS TO SOURCES OR IGNITION AND BUILDING OPENINGS.**
4. THE OUTSIDE TERMINAL OF EACH SERVICE REGULATOR VENT MUST:
    - HAVE A RAIN AND INSECT RESISTANT SCREEN
    - BE LOCATED AT A PLACE WHERE ANY VENTING GAS CAN ESCAPE FREELY INTO ATMOSPHERE
    - BE AWAY FROM ANY WINDOWS, DOORS, SOFFIT VENTS OR ANY OPENINGS WHERE GAS CAN ENTER THE BUILDING. MAINTAIN A MINIMUM OF 18 INCHES HORIZONTAL CLEARANCE IF THAT OPENING IS WITHIN 6 FEET VERTICALLY OF THE VENT TERMINUS. **WINDOWS THAT ARE DESIGNED BY MANUFACTURER *NOT TO OPEN* ARE EXEMPT FROM THE 18 INCH RULE**
    - BE PROTECTED FROM DAMAGE WHERE ICE ACCUMULATION MAY OCCUR
    - IT IS PREFERRED THAT REGULATOR VENTS BE INSTALLED AT A HEIGHT 18 INCHES ABOVE GRADE, HOWEVER, THE MINIMUM ALLOWABLE VENT HEIGHT SHALL BE 12 INCHES ABOVE FINAL GRADE. IN CASES OF KNOWN FLOOD LOCATIONS, THE PREFERRED REGULATOR VENT HEIGHT ABOVE THE FLOOD HEIGHT IS 18" (12" MINIMUM).
  5. THE METER ASSEMBLY SHALL BE LOCATED TO PREVENT DAMAGE BY VEHICLES AND MECHANICAL EQUIPMENT. WHERE THIS IS NOT PRACTICAL, ADDITIONAL PROTECTION SHALL BE INSTALLED. SEE MTRS-6060.
  6. GALVANIZED PIPE AND FITTINGS FOR VENT PIPING IS PREFERRED (REQUIRED ON L.I.) PROPERLY COATED BLACK IRON PIPE IS PERMITTED.
  7. IF A VENT NEEDS TO BE EXTENDED, STRAIGHT PIPING IS PREFERRED, BUT IF NOT PRACTICAL, A VENT LINE "TRAP" IS ACCEPTABLE.
    - ON OUTSIDE METER SETS, AN INSULATED UNION (LI) OR INSULATED COUPLING (NY) IS PREFERRED ON ALL VENT LINES UNDER 3' AND REQUIRED ON ALL VENT LINES > 3'.
    - ON **ALL** INSIDE SETS, AN INSULATING UNION OR INSULATED COUPLING IS REQUIRED ON THE VENT PIPING. THIS INSULATED UNION OR INSULATED COUPLING SHALL BE LOCATED AS CLOSE TO THE REGULATOR AS POSSIBLE.
  8. IT IS PREFERRED THAT THE METER AND RISER NOT BE LOCATED UNDER A WINDOW.
  9. VENT LINES SHOULD BE INSTALLED ABOVE GRADE. BELOW GRADE VENT LINES SHOULD BE AVOIDED. HOWEVER, WHERE IT IS NOT POSSIBLE, VENT LINES INSTALLED UNDERGROUND SHALL BE PROTECTED FROM CORRODING. THIS INCLUDES WRAPPING THE ENTIRE LINE WITH APPROVED COATING 030031-CS, INSTALLING A 3 LB BAG ANODE (ITEM ID 9339401) (OR LARGER) AND INSTALLING AN INSULATING FITTING BETWEEN THE REGULATOR AND THE BELOW GRADE SECTION (TYPICALLY INSIDE THE BUILDING). **ANY NEW VENT LINE THAT PASSES THROUGH A CONCRETE OR MASONRY WALL OR FOUNDATION, SHALL BE SLEEVED AND THE ANNULAR SPACE SHALL BE SEALED TO PREVENT WATER INTRUSION.** FOR SITUATIONS THAT ARE NOT COVERED BY THE PROVISIONS OF THIS STANDARD, CONTACT GAS ENGINEERING.
  10. ON LARGE RESIDENTIAL, COMMERCIAL & INDUSTRIAL SETS WHERE LARGE FORCED AIR INTAKE SYSTEMS ARE PRESENT, ENGINEERING APPROVAL IS REQUIRED FOR REGULATOR/RELIEF VALVE TERMINATION POINTS.
  11. ON EXISTING INSTALLATIONS WHERE UNDERGROUND VENT LINE IS FOUND, THE VENT LINE SHOULD BE RELOCATED ABOVE GROUND. IF THIS IS NOT POSSIBLE, IT MUST BE PRESSURE TESTED AT 3 PSIG AND INSPECTED FOR CORROSION. IF IT PASSES THE PRESSURE TEST AND THE PIPE IS VISUALLY ACCEPTABLE, IT THEN SHALL BE CATHOLICALLY PROTECTED PER 030031-CS AND BROUGHT IN TO COMPLIANCE AS DESCRIBED IN NOTE 9.

**CLEARANCE GUIDELINES:**

SITUATION	MINIMUM DISTANCE
STANDARD ELECTRIC METER	12 INCHES HORIZONTAL DISTANCE FROM GAS METER TO ELECTRIC METER 36 INCHES PREFERRED / 12 INCHES MIN. DISTANCE FROM REGULATOR VENT TERMINUS TO ELECTRIC METER
IGNITION SOURCE	36 INCHES RECOMMENDED / 18 INCHES MINIMUM FROM GAS METER AND <b>36 INCHES MINIMUM DISTANCE FROM REGULATOR VENT TERMINUS TO SOURCE OF IGNITION</b>
WINDOW, DOOR, SOFFIT VENT, OTHER OPENINGS INTO BUILDING	18 INCHES HORIZONTAL AND 6 FEET VERTICAL (WHERE PRACTICAL) FROM REGULATOR VENT TERMINUS
VENT TERMINUS UNDER FLAT OVERHANG	IF OVERHANG PROTRUDING LESS THAN 6 FEET VENT TERMINUS IS ACCEPTABLE UNDER OVERHANG.
CENTRAL A/C UNIT	36 INCHES PREFERRED / 18 FEET MINIMUM FROM GAS METER 36" FROM REGULATOR VENT TERMINUS
VENT TERMINUS UNDER AWNING/CANOPY WITH SIDES ENCLOSED	18 INCHES HORIZONTAL
FORCED AIR INTAKE LARGE RESIDENTIAL, COMMERCIAL OR INDUSTRIAL	REQUIRES ENGINEERING APPROVAL
VENT TERMINUS CLEARANCE ABOVE FINAL GRADE	18 INCHES PREFERRED / 12 INCHES MINIMUM
VENT TERMINUS CLEARANCE ABOVE KNOWN FLOOD LINE	18 INCHES PREFERRED / 12 INCHES MINIMUM
VENT TERMINUS TO A CATEGORY 1 DIRECT VENT HEATERS	3 FEET FROM INTAKE OR EXHAUST OR PER MFRG. SPECS. WHICHEVER IS GREATER
VENT TERMINUS TO SEWER VENT	18 INCHES RECOMMENDED

# APPENDIX K

## **LINKS TO VARIOUS MANUFACTURES:**

### **HEATING MANUFGACTURERS**

[AMERICAN STANDARD](#)

[AO SMITH](#)

[BAXI BOILERS](#)

[BOSCH](#)

[BUDERUS](#)

[BURNHAM](#)

[CARLIN](#)

[CARRIER](#)

[EMERSON](#)

[HONEYWELL CONTROLS](#)

[MIDCO ECONOMITE](#)

[MODINE](#)

[PEERLESS BOILERS](#)

[POWER FLAME BURNERS](#)

[REZNOR UNIT HEATERS](#)

[RHEEM](#)

[SLANT FIN](#)

[TAKAGI](#)

[TECHTANIUM](#)

[TRANE](#)

[TRIANGLE TUBE BOILERS](#)

[TURBO MAX](#)

[UTICA BOILERS](#)

[WALLHUNG BOILERS](#)

[WEIL-MCLAIN](#)

### **CSST MANUFACTURERS**

[GASTITE](#)

[OMEGAFLEX TRAC PIPE COUNTER STRIKE](#)

[WARDFLEX](#)

**National Grid**

**Blue Book - Part 2**

**TC-2015**

**Requirements for Installation of  
Automatic Dual Fuel Burners and Equipment at  
Temperature Controlled & Temperature Interruptible (TC  
& TI) Sites**

**Blue Book - Part 2**

**TC-2015  
Requirements for Installation of  
Automatic Dual Fuel Burners and Equipment at Temperature Controlled &  
Temperature Interruptible (TC & TI) Sites  
and  
Straight Gas Utilization Equipment of 400,000 Btu/hr and Higher**

**TABLE OF CONTENTS**

- 16.0 Introduction and Scope for the Installation of Automatic Dual Fuel Burners and Equipment at Temperature Controlled & Temperature Interruptible (TC&TI) Sites**
- 17.0 Gas Service Metering, Piping and Available Pressures**
- 18.0 Appliance Regulators, Gas Train Components and Gas Control Venting**
- 24.0 Outdoor Temperature Controls**
- 25.0 Design and Control of Automatic Changeover Circuits**
- 26.0 Co-generation, Process and Auxiliary Equipment**
- 27.0 Propane as the Alternate Fuel**
- 29.0 Required Site Inspections, Burner Submittals and Start-Up**

## 16.0 Introduction and Scope for the Installation of Automatic Dual Fuel Burners and Equipment at Temperature Controlled & Temperature Interruptible (TC & TI) Sites

### 16.1 Introduction

The **Blue Book-Part 2, TC-2015** is an update of the National Grid Specification for Installation of Dual Fuel Automatic Temperature Controlled Burners and Equipment at Interruptible Sites in both New York City (Brooklyn, Staten Island, Queens) and Long Island (Nassau, Suffolk, Rockaways). Where installation requirements between New York City (NYC) and Long Island (LI) differ, the specific differences will be explained. **This document replaces and supersedes National Grid’s specification TC-2005.**

Burners intended for use under the National Grid Temperature Controlled Rate (Public Service Commission Service Classification No. 6 for New York City and No. 12 for Long Island) must be factory designed and built to this specification to operate automatically via a signal from an outdoor temperature controller. The customer shall install the dual-fuel equipment necessary and at all times maintain a sufficient stand-by alternate fuel to utilize same in the event that transfer of fuel sources is required. Dual-fuel burners wired for manual (gas-off-oil) fuel changeover will not work automatically with an outdoor control and will only be accepted for this rate for facilities manned on a 24 hour per day, 7 day per week basis by personnel who are capable of switching to the alternate fuel. It should be noted that the temperature setting of the FS/AMR for “semi-automatic” control is normally set 5 degrees F higher than for automatic fuel changeover.

All territories supplied by National Grid receive natural gas of approximately 1,000Btu/Ft<sup>3</sup> and a specific gravity of 0.6 delivered from either the low pressure or high pressure system. Where high gas pressure main can be made available to supply the load and where approved by the National Grid Engineering Department, a National Grid service regulator together with other components and vent lines are required to be installed at the site. In these cases, the National Grid service regulator setting will not normally exceed 3 psig in NYC and 5 psig in LI, and is normally set lower. The final setting will depend on the firing rate and total load of the equipment at the site. Prior to proceeding with the installation of a gas service off a high pressure main or booster elevated service off a low pressure main, installers must obtain the meter regulator/header or booster layout prepared by the National Grid Engineering Area. All questions regarding available gas pressure supply and meter layouts must be referred to the National Grid Project Manager for the location involved.

Confirmation of approval that a contract is acceptable and a gas supply is available must be obtained from Gas Sales and Marketing of NYC or LI before proceeding with a sale or installation of any equipment under this rate.

## 16.2 Scope

All gas and oil utilization equipment must be installed per the manufacturer's recommendations and be built to comply with the applicable performance standard of The American National Standard Institute (ANSI). In some cases this may require that the supplied equipment be constructed and installed to standards more stringent than those contained in this specification however, the requirements of this specification must always be adhered to as the minimum standard for the equipment.

All burners, components and equipment must be listed by Underwriters Laboratory (UL), Factory Mutual (FM), IAS International (AGA,CGA) with US indicator, or other nationally recognized testing agency and by the City of New York or the local municipality having jurisdiction. Further, all boilers and pressure vessels require American Society of Mechanical Engineers (ASME) certification.

Where Factory Mutual (FM), Industrial Risk Insurers (IRI), or other carrier safety requirements govern customer's insurance coverage, these must be complied with, but in all cases the requirements of this specification must be adhered to as the minimum standard for equipment construction and installation.

All installations in NYC and LI shall comply with the most stringent and latest version of all applicable state, federal and local municipality codes, rules and regulations in addition to The Fuel Gas Code of New York State and The New York State Industrial Code Rule 4 and 14 for Construction and Installation of High and Low Pressure Boilers. Public schools must conform to the standards of the School Construction Authority (SCA). New York City installations must further comply with The National Fuel Gas Code (NFPA54, ANSI Z223.1), Department of Air Resources Engineering Criteria for Fuel Burning Equipment and the New York City Administrative Code. Long Island propane installations must be built to conform to the standards of the LP-Gas Code NFPA58 and The Fuel Gas Code of New York State.

Equipment design, construction and function must conform to the requirements of the following applicable national standards; The National Fire Protection Association (NFPA) Standard for the Installation of Oil Burning Equipment NFPA 31, The American National Standard Institute (ANSI) for Gas Utilization Equipment in Large Boilers ANSI Z83.3 or Gas Fired Low Pressure Steam and Hot Water Boilers ANSI Z21.13, Standard for Single Burner Boiler Operation NFPA85, The American Society of Mechanical Engineers (ASME) Controls and Safety Devices for Automatically Fired Boilers ASME-CSD-1, Underwriters Laboratory Commercial & Industrial Standards UL795 for gas burners and UL296 (ANSI Z96.2) for oil burners, Standard for the Installation and use of Stationary Combustion Engines and Gas Turbines NFPA37, Standard for Oven and Furnaces NFPA86.



## 17.0 Gas Service Metering, Piping and Available Pressures

### 17.1 General

Customer shall submit a gas load letter to the Gas Sales Area for review and processing. The load letter shall detail the manufacturer, model number, firing rate, pressure required and service classification of all equipment proposed to be installed at the site. Engineering will analyze the request to determine the impact of the additional load on the National Grid system and determine if the new load can be supplied by high pressure service, low pressure service or low pressure service with a booster.

### 17.2 Main Gas to the Burner

Metering equipment and associated house piping for a commercial, industrial or governmental location shall be installed in accordance with The National Fuel Gas Code for NYC, The Fuel Gas Code of New York State for LI, the local municipality having jurisdiction and National Grid requirements as detailed in **The National Grid Blue Book-Part 1**. A separate meter will be supplied for the Automatic and Semi-Automatic Temperature Controlled Rate, Public Service Commission Service Classification No. 6 for New York City and No. 12 for Long Island. Only the equipment approved for this rate classification shall be supplied from the Temperature Controlled Interruptable Rate meter. For a general guide of supplied pressure according to firing rate, the design parameters listed in this section can be utilized in determining the approximate inlet pressure that will be available. In order to insure that installations will operate in a satisfactory manner, the customer's equipment must be matched to National Grid's service and metering equipment.

#### 17.2.1 Large Gas Inputs

It should be noted that some appliance gas pressure regulators (particularly pilot-operated regulators) require substantial gas pressure for operation. National Grid will supply higher pressures above 7" w.c. as described in Section **17.3, 17.5** and Table 1, only where manufacturer's data is received to warrant the higher pressure requirement. This information includes; required burner manifold pressure, expected furnace back pressure, firing rate, model and catalog number of the appliance regulator to be used, and the pressures required before and after the appliance regulator.

<b>Table 1</b>					
<b>DESIGN &amp; OPERATING RANGE FOR BURNERS ON HIGH PRESSURE SYSTEM</b>					
<b>Firing Rate</b>	<b>Nominal Pressure Available at Inlet to Train</b>	<b>Maximum Pressure Drop In House Piping</b>	<b>Pressure Out of Meter</b>	<b>Pressure Drop in Meter</b>	<b>National Grid Regulator Max. Set Point</b>
Up To 4,500 chf	6.2" w.c.	0.3" w.c.	6.5" w.c.	0.5" w.c.	7" w.c.
4,501 cfh to 6300 cfh	11.5" w.c.	0.5" w.c.	12.0" w.c.	2.0" w.c.	14" w.c.
6,301 to 8,400 cfh	23" w.c.	3.0" w.c.	26.0" w.c.	2.0" w.c.	1 psig
8,401 to 12,000 cfh	48" w.c.	6.0" w.c.	54.0" w.c.	2.0" w.c.	2 psig
12,001 to 22,000 cfh	73" w.c.	9.0" w.c.	82.0" w.c.	2.0" w.c.	3 psig

Notes:

1. Burners over 22,000 CFH require special pressure considerations.
2. The maximum pressure drops shown are for the upper range of burner firing rates. Where burner equipment requires less pressure than specified the pressure drop in the house piping will be less.
3. These are general guidelines for equipment with the indicated firing rates. Where manufacturer's/contractor's burner and house piping requirements differ, the National Grid regulator setting will adjusted.

### 17.3 High Pressure Service

Where a high pressure gas main is available and where approved by the National Grid Engineering Department, a National Grid service regulator together with other components and vent lines is required to be installed by the customer/contractor. The National Grid service regulator setting will normally be 7" w.c. unless manufacturer's data is received to warrant higher pressure. Generally, the service regulator setting will not exceed 3 psig in NYC and 5 psig in LI and its final setting will depend on the total load at the site. In NYC where pressure of more than 3 psig is required to fire the burner, special permission must be obtained from the Commissioner of Buildings as per NYC Administrative Code Reference Standard RS-16. In LI where pressure of more than 5 psig is required to fire the burner, the requirements of the local municipality must be followed.

Before proceeding on a high pressure gas service installation, installers must obtain the meter regulator/header layout prepared by the National Grid Engineering Area. All questions regarding available gas pressure must be referred to the National Grid Project Manager for the location involved.

## **17.4 Low Pressure Service**

Services off the low pressure distribution system do not require a National Grid service regulator. National Grid provides gas to customers where the meter outlet pressure measured immediately downstream of the gas meter can vary between 4" and 6" w.c. When purchasing gas utilization equipment to operate on the low pressure system it is recommended that the equipment chosen require no more than 3.5" w.c. pressure at the burner head. Also, the house piping shall be so designed for a maximum of 0.2" w.c. pressure drop in piping from the meter to the equipment. Burners being supplied off the low pressure distribution system without a booster will normally have a maximum input of 4,500 CFH.

## **17.5 Gas Booster off Low Pressure Services**

Normally, burners with input requirements over 4,500 CFH and/or pressure requirements higher than 6" w.c. will require a gas booster where high pressure main is not available. Depending on the location of the site within the National Grid system an exception to booster use may be made for burner firing rates as high as 5,000 CFH where high flow gas train design and components are utilized to minimize pressure drop.

### **17.5.1 General**

1. In all cases, the National Grid Engineering Area determines which system (low or high pressure mains) will provide gas for the approved load and the supply pressure. Where burners require gas pressures higher than that available on the low pressure main a gas booster may be utilized but only as provided in these specifications.
2. Only one gas booster per gas service is allowed. National Grid Engineering must approve exceptions to this.
3. The National Grid Engineering Area must review all gas booster applications, and proposed booster locations before installation.
4. Before proceeding on a booster gas service installation, installers must obtain the meter and booster switch drawing prepared by the National Grid. All questions must be referred to the National Grid for the location involved.
5. Gas boosters shall be installed according to manufactures specifications and local, State and Federal codes.

### 17.5.2 Gas Booster Wiring

1. Gas boosters shall be wired into the burner operating circuits such that they will run only when the burner is firing on gas, and shall not run during the burner off period or when the alternate fuel is being utilized. For sites with multiple burners isolating relays are required for booster control.
2. A general purpose low gas pressure switch shall be connected in series with the booster motor starter coil. In situations where the meter room is classified as a Class 1 Hazardous Area requiring explosion proof equipment, the low gas pressure switch must be located in an appropriate location outside the meter room. When this is not practical and it must be located inside the room. Additionally, if the low gas pressure switch is the only general purpose device that will be located inside the meter room, that meter room must be treated as a Class 1 Hazardous Area.
3. The National Grid low gas pressure switch is independent of the low gas pressure switch supplied on the burner gas train. If the gas booster motor stops or loses the pressure boost, the burners must shut down. The low gas pressure switch on the burner train must be adequate in range and setting to insure such burner shutdown as under firing is not permitted. Therefore all equipment supplied by a booster regardless of the firing rate must be equipped with a low gas pressure switch on the gas train (Refer to drawing CS-MET013).

### 17.5.3 Gas Booster Piping

1. The booster shall not supply pilot gas.
2. The low gas pressure switch shall be installed at the service entrance on a 1" weldolet or welded tee to accommodate the switch. National Grid does not wire or pipe this low gas pressure switch.

## 17.6 Pilot Gas Piping to the Burner

On Temperature Controlled Installations, all pilot gas is to be supplied by a Firm Rate low pressure meter. If the alternate fuel is to be ignited by direct spark ignition (see Section 21.10) or the requirement for a Firm Rate gas pilot is deemed by National Grid to be impractical, on a site specific basis, special permission may be given to take pilot gas from the Interruptable Rate gas meter.

## 18.0 Appliance Regulators, Gas Train Components and Gas Control Venting

### 18.1 General

1. The appliance and pilot regulator shall be rated for the flow and operating pressure requirements for the burner. The regulator spring is not to be bottomed-out or set too low. All such springs should regulate in the active portion of their operating characteristic curve. Regulators must be adjusted for

proper flame characteristics and smooth operation of gas burner trains for the full firing range of the burner.

2. On elevated pressure systems of over 14" w.c., all regulators must be vented outside the building to atmosphere. On services supplying 14" w.c. and less, regulators with valve bodies 1-1/4" and larger must be vented outside the building to atmosphere. Regulators with valve bodies smaller than 1-1/4" and those installed on services supplying 14" w.c. and less may be equipped with approved appliance vent limiters in lieu of outside venting. The Siemens SKP series of combination valve/regulator (with integral vent limiter) or approved equal may be utilized for their rated pressures and body sizes when installed as per this specification.
3. Pilot regulators that conform to the size and pressure limits as detailed in Item 2 above, may be installed with approved vent limiters in lieu of outside venting.
4. Vents are to be a minimum 3/4" pipe size, but in all cases shall be of sufficient size to prevent the restriction of flow due to backpressure. The Vent line from the normally open vent valve (NOVV) is not to be connected into a common header with the gas train regulator vents or other NOVVs. Gas train high and low gas pressure switch vent lines may be connected to the regulator vent lines. All appliance vents are to terminate a minimum of six feet above outside grade at least 18" laterally from any building opening, window or door and shall be equipped with weatherproof insect resistant vent caps or fittings. Vent line sizing for gas pressure regulators, in relation to length of run, shall be in accordance with Table 2, the number of 90 deg. bends should be minimized.
5. For two or more burners operating at the same service pressure, installers may manifold atmospheric vent lines into a common header. Vent lines off normally open vent valves are not to be connected to other type vent lines or manifold into a common header. Bleed lines off regulator/diaphragm gas valves are not to be manifolded into a common header. Manifolded atmospheric vent lines must be connected to a common vent line having a cross sectional area not less than the area of the largest vent plus 50 percent of the combined area of all the additional vents with allowance for length of run and fittings.
6. Vent Sizing table for regulators.

Table 2 <b>Regulator Vent Lines</b>	
Vent Line Size (Inches)	Maximum Length (Equivalent Feet)
3/4	40
1	80
1 1/4	150
1 1/2	225

**18.2 Normally Open Vent Valve (NOVV)**

Where a NOVV is installed between the two main gas valves, the vent valve piping must be run outside the building to atmosphere separately from the regulator vent and all other NOVV lines. Based on site conditions, it may be required for the NOVV piping to be terminated above roof level to allow better dissipation of vented gas. Vent lines for NOVV's shall be sized in accordance with UL Standard 795 (Table 3) as a minimum. Requirements of applicable insurance carriers for sizing vent lines in relation to length of run must also be adhered to.

<b>Fuel Line Size (Inches)</b>	<b>Vent Line Size (Inches)</b>
Up to 1½	¾
2	1
2 ½	1 ¼
3	1 ¼
4	2
5	2
6	2 ½
8	3

**Sections 19.0 – 23.0 have been deleted**

## **24.0 Outdoor Temperature Controls**

### **24.1 General**

FS/AMR controller, outdoor temperature probe and stepdown transformer are supplied by National Grid and are to be installed (Refer to Drawing 1) in this section. The FS/AMR is used to automatically switch the burner to the alternate fuel or in the case where a FS/AMR is not required (Interruptible) sites will receive notification to switch to the alternate fuel. The customer is responsible to properly maintain the FS/AMR, burners and equipment at the site to be fully functional and able to change to the alternate fuel.

The outdoor control and circuit shall not be used to start-up or control auxiliaries, only National Grid controls shall be wired in this circuit

National Grid shall have sole control of adjusting and setting the outdoor changeover control. It shall be installed in a location that is accessible for inspection and calibration. The sensing element of the changeover control shall be securely mounted without touching the building surface. National Grid requires that the outdoor sensor be mounted on the north side or northerly exposure of the building. Location of the outdoor control can be determined during pre-installation site inspection.

Outdoor control sensors are not to be located below grade or in any location that would contradict or interfere with its temperature-sensing function. It shall not be located where it is exposed to direct or reflected sunlight and must be a minimum of three (3) feet above ground level and away from windows, doors, flues, vents, heating devices or openings from the heated area. It shall be located so that it will respond quickly to changes in outdoor temperature.

To obtain the FS/AMR controls, contact National Grid. Only one outdoor control is provided per boiler room or plant. Where there are two or more burners, the outdoor control circuit shall be isolated using suitable magnetic switching relays.

### **24.2 Outdoor Temperature Controller Installation**

Installation of the FS/AMR outdoor temperature control shall be in accordance with the manufacturer's instructions and NFPA70. NYC installations must comply with the New York City Electrical Code

#### **1. Mounting Controller**

- a) The FS/AMR shall be mounted indoors on a 4" square "1900" series electrical box using the two screws provided.
- b) The electrical box with controller must be mounted in a dry location, away from excessive heat or cold and be readily accessible to permit set-up of the "Digi-Span and easy viewing of the display.

2. Installing Stepdown Transformer

- a) The primary circuit for the supplied 120V/24V step-down transformer shall be connected to a separate fused burner control circuit.
- b) The transformer shall be mounted adjacent to the controller “1900” box and properly grounded.
- c) Secondary wires of the transformer are an NEC listed Class 2 circuit. Connection to the FS/AMR terminals shall be made with fork-end solderless connectors.
- d) The transformer is to be used solely for the purpose of supplying power to the FS/AMR and other National Grid equipment. It is not to be used as a power source for any customer equipment or relays.

3. Locating Sensor and Sensor Wire

- a) Sensor shall be located on the north wall. Where site conditions warrant an alternate location, the National Grid Gas Sales Project Manager shall be consulted for approval.
- b) Sensor lead provided by National Grid, may be used outdoors.
- c) The sensor wires can be extended up to 500 feet by splicing #18 gauge shielded wire to the supplied cable. The wire shield must be grounded at a single point inside the building to provide effective protection from electro-magnetic interference. For outside runs, wire suitable for outdoor locations shall be used.
- d) All sensor wire splicing shall be via mechanical means using solderless barrel connectors.
- e) The sensor wire shall be protected from mechanical damage, vandalism and must be run independent of all electric circuits.

4. Completion

- a) When the outdoor control is installed and wired-in, National Grid must be notified in order for the FS/AMR to be set , the switching over of fuels checked out, and the Digi-Span outdoor control sealed.

**24.3 Control and Monitoring of New York City Sites with the Exception of the Rockaways**

For remote control of New York City sites with the exception of the Rockaways, a Fuel Selection Module (FSM) is used. The FSM is supplied and installed by National Grid. For remote monitoring of gas usage, National Grid will install a meter reading device on the gas meter.



### **24.3.1 Automatic Sites**

All automatic TC installations require the customer/contractor to install a FS/AMR unit for automatic switching of the equipment based on outside temperature. National Grid will supply drawings for the wiring and layout of this equipment. For remote control capability, National Grid will install and wire the Fuel Selection Module (FSM) into the FS/AMR control unit.

### **24.3.2 Semi-Automatic Sites**

The customer must install an alarm panel and bell to signal an operator when switching of fuels is required. The panel must be wired to the FS/AMR and designed to alert plant personnel when both switching to oil is required and back to gas. National Grid will supply drawings for the wiring and layout of this equipment.

## **24.4 Control and Monitoring of Long Island Sites Including the Rockaways**

### **24.4.1 Automatic Sites**

All automatic TC installations require the customer/contractor to install a FS/AMR unit for automatic switching of the equipment based on outside temperature. Cabling connecting the FS/AMR, the 12 VDC Power Supply and the Electronic Volume Corrector (EVC) on the meter is also required to be installed by the customer. The EVC/FS/AMR interconnection wiring and a dedicated phone line will allow National Grid to override the temperature control function of the FS/AMR unit, when necessary. National Grid will supply drawings for the wiring and layout of this equipment.

1. Belden cable #8690 (or approved equivalent) is the required cable for the connection between the Digispan, the 12VDC power supply and the EVC (located on the gas meter). This is a three pair cable comprised of 18 gage, stranded conductors. This cable is to be supplied and installed by the customer/contractor. If the length of the Belden Cable will exceed 500', National Grid Engineering must be consulted for the appropriate cable or switching relays needed to be used. National Grid will terminate this cable at the FS/AMR, the power supply and the EVC.
2. The 12 VDC power supply will be supplied by National Grid. This unit must be installed near the FS/AMR and provided with a separate 120 VAC supply.
3. The customer is responsible for installation and maintenance of a dedicated telephone line for connection to the automated meter reading equipment. The telephone line will be installed to a location near the gas meter specified by National Grid.

4. Outdoor gas meters-The Belden cable and the dedicated telephone line must be installed in a 3/4" rigid conduit to outside meter sets (including remote meter pads). A weatherproof box capable of accepting a 1/2" fitting will be installed on the meter end of the conduit. Sufficient lengths of Belden cable and telephone line will be left coiled inside the weatherproof box to reach the EVC. National Grid will install a flexible conduit from the weatherproof box to the EVC, terminate Belden cables at the Digispan and the EVC, and terminate the dedicated telephone line at the EVC.
5. Indoor gas meters-The Belden cable and dedicated telephone line are not required to be installed in conduit. However, these cables should be secured along their routing to the gas meter location to prevent damage from routine activities in the area. Both cables should be left coiled near the gas meter

#### **24.4.2 Semi-Automatic Sites**

1. The customer must install an alarm panel and bell to signal an operator when switching of fuels is required. The panel must be wired to the FS/AMR and designed to alert plant personnel when both switching to oil is required and back to gas. For monitoring, the customer/contractor is responsible for the installation & maintenance of a dedicated telephone line for connection to the automated meter reading equipment. The telephone line will be installed to a location near the gas meter to be specified by National Grid. National Grid will supply drawings for the wiring and layout of this equipment.
2. Outdoor gas meters-The dedicated telephone line must be installed in a 3/4" rigid conduit to outside meter sets (including remote meter pads). A weatherproof box capable of accepting a 1/2" fitting will be installed on the meter end of the conduit. Sufficient lengths of telephone cable will be left coiled inside the weatherproof box to reach the EVC. National Grid will install a flexible conduit from the weatherproof box to the EVC and terminate the dedicated telephone line at the EVC.
3. Indoor gas meters - - The dedicated telephone line is not required to be installed in conduit. However, this cable should be secured along its routing to the gas meter location to prevent damage from routine activities in the area. The telephone cable should be left coiled near the gas meter.

### **25.0 Design and Control of Automatic Changeover Circuits**

#### **25.1 Burner Fuel Changeover Design Requirements**

The following controls are required for automatic fuel switching operation of all dual fuel burners intended for control with the FS/AMR. While the following items will effect automatic switching of fuels, they will not correct improper burner operating sequences, improper combustion characteristics, improper chimney draft or guarantee firing rates. Correct operation of fuel switching and of all these parameters must be demonstrated to

the National Grid Technician and documented during the equipment start-up. Burners for the Temperature Controlled Rate must have;

1. Proper flame safeguard controller and programmer, operating and safety features as required for the burner firing rate.
2. Cross-interlocked UL listed, industrial grade fuel changeover appliance relays wired to break and control the oil and gas operating limits, fuel valves, safety string and required equipment.
3. An individual “Auto-Off-Oil” manual selector switch with positive center off position. A switch with built-in mechanical interlock is required for positive center “Off” delay. When this switch is in the “Auto” position, the FS/AMR is in full control of the switching of fuels. When the switch is in the "Oil" position, the burner must only fire on oil. In the “Off” position the burner must not be firing on any fuel. It should be noted, that it will be required that this switch break the operating limits when in the “Off” position if the changeover relays do not provide that function.
4. Burner fuel changeover relays must be protected by individual gas and oil time delays to insure that upon switching from gas to oil or oil to gas, the burner will not simultaneous fire both fuels and will go through a post-purge and pre-purge period before firing on the new fuel. A fixed time delay of a minimum of 30 seconds for fuel changeover is required. The fuel valve relay logic shall be so designed such that upon fuel switching, the main valves of the alternate fuel are not energized prior to the opening of the burner operating limit and initiation of post-purge. For manual burners the “Auto-Off-Oil” fuel selector switch is to provide these switching functions.

## 25.2 Control Panel and Wiring

1. The control system shall be furnished in a pre-wired, pre-tested control cabinet and shall contain all the necessary circuit protection, motor starters, switches, combustion safety controls, transformers and relays. The cabinet shall meet the NEMA rating for the area in which it is installed.
2. All wiring is to be color coded and/or numbered and of sufficient gauge to carry the designed load.
3. Fuel transfer relays and fixed time delays shall be provided to accomplish the automatic switching of fuels. These relays are to be activated by the automatic outdoor changeover control. UL listed, industrial grade appliance relays with tinned switching contacts are to be used for this purpose.
4. Two switches are to be provided for all automatic and semi-automatic changeover burners:
  - a) Burner “On-Off” switch to remove power from the operating limit

- b) “Auto-Off-Oil” fuel selector switch wired to open the operating limit circuit when in the “Off” position. A switch with built-in mechanical interlock is required for positive center “Off” delay.
5. Marked panel terminals shall be provided on the burner for wiring of the 120VAC switching contacts of the FS/AMR outdoor control.

### **25.3 Master Control of Two or more Burners**

Only one outdoor control is installed in each boiler room. For control of two or more burners the outdoor control must be electrically isolated from the burner control circuits, no burner interlocks are to be wired into this circuit. This isolation is accomplished by using a magnetic switching relay as the master control switch for the automatic burners and equipment at the site.

## **26.0 Co-generation, Process and Auxiliary Equipment**

### **26.1 Co-generation Equipment**

Co-generation equipment, such as prime movers, may be the only equipment wired off the outdoor control, or they may serve as auxiliaries to a boiler of a large dual-fuel installation. The prime movers may change fuels automatically, or the changeover may be done manually by plant operators at sites manned 24 hours/day and 7 days/week. Interlocking with the outdoor control is different, in these cases:

1. Where the Prime mover is the only equipment wired off the outdoor control, its control circuit must be integrated into the outdoor control for automatic fuel changeover. If the changeover is manual, then the outdoor control activates a changeover alarm and panel light.
2. Where Prime movers have manual fuel changeover and serve as auxiliary equipment in a boiler installation with automatic fuel change over them require a separate outdoor control. This second outdoor control is set at a higher temperature than the one serving the boilers.

#### **26.1.1 Low Gas Pressure Switch**

1. Prime Movers Supplied from Low Pressure Mains: A low gas pressure switch shall be installed upstream of the appliance regulator. Switch shall be wired so as to interrupt the prime mover in case of a low gas pressure condition.
2. Prime Movers Supplied From Boosted Lines: A low gas pressure switch shall be installed in the boosted line, and interlocked in series with other gas booster/prime mover safeties so as to interrupt the prime mover in case of a low gas pressure condition. This switch is in addition to the National Grid supplied low gas pressure switch installed at the service entrance.

## 26.2 Hot Water Heaters

### 26.2.1 Summer Water Heaters

1. Such hot water heaters may have straight-gas burners or dual-fuel burners but require 120 volt control.
2. Where the boiler supplies hot water in winter only an alternate gas-fired water heater for summer use may be taken off the Temperature Controlled Rate gas meter provided gas flow can be correctly registered. The settings and hand valve operation of existing hot water supply systems remain the responsibility of the building's superintendent.
3. Summer water heater controls shall be interlocked electrically with the heating boiler using a multi-pole, double-throw manual switch, wired into the burner limit circuits such that either the boiler is on, or the summer heater is on not both simultaneously.
4. On existing Temperature Controlled Rate sites water heaters are not to be added to the gas line without permission by National Grid. Consult National Grid Project.

### 26.2.2 Water Heaters with Dual Fuel Burners

1. If the water heater is for summer use only, then the requirements of Section **26.2.1** for straight gas burners apply.
2. Where the water heater is for year-round use it must be wired and tooled for automatic fuel changeover with the proper programmer and the burner circuit interlocked with the outdoor temperature control.
3. The burners and gas train equipment are to be compatible with the existing boiler gas supply pressures, or the installer must provide suitable protection.

### 26.2.3 Straight Gas Fired Water Heaters of 75,000 Btu/Hr or Less

1. Burners that do not require electrical power for operating and control shall be fitted with a suitable valve locking device or lockable gas cock.
2. Small Type I gas water heaters (75,000 Btu/Hr. or less) are permitted only when the gas flow can be correctly registered on the Temperature Controlled Rate meter.
3. Water heaters having standard gas trains certified for 14" w.c. maximum, must not be connected to gas supply piping operating at higher pressure unless suitable protection such as a lock-up regulator is provided.
4. Pilot gas for the water heater must be taken off a firm rate supply line.

### **26.3 Miscellaneous Process Equipment**

1. All packaged boilers intended for automatic fuel changeover are required to conform to the requirements of this specification. Equipment will not be accepted for automatic changeover where the fuel connections must be broken or burners must be swung in and out by plant operators.
2. Where it is impractical to change fuels automatically, packaged boilers may operate on a "semi-automatic" fuel changeover basis with the approval of National Grid. This written approval requires that the customer sign a "semi-automatic" agreement. In this case, the outdoor control will operate a light and sound an alarm alerting plant operators to change fuels manually. The alarm must sound when changing over from either fuel and be manually reset by the operator. It should be noted that the temperature setting of the FS/AMR for "semi-automatic" control would normally be set 5 degrees F higher than for automatic fuel changeover.
3. Gas dryers, gas-fired oven assemblies, manifold burner systems, metal-melting and annealing furnaces, and large gas engines, may operate on this rate either on an automatic or "semi-automatic" changeover basis.
4. On automatic changeover installations, straight gas-fired equipment would be shut down immediately when the outdoor control drops to the set point. For gas-fired annealing ovens, process assemblies, etc., where immediate shutdown is not acceptable, shutdown can be after a time delay of up to 4 hours, subject to National Grid approval.
5. Where any "semi-automatic" process equipment on this rate supplies all or part of the building heat requirements in winter, the plant operators are responsible to be on site 24 hours a day, 7 days a week to switch to the alternate fuel if necessary. For premises where such equipment does not provide building heat with plants closed at night and weekends, all equipment must be shutoff. Further, a manual switch is required ahead of the outdoor control, to disable the "semi-automatic" alarm when the plant is not manned.

### **27.0 Propane as the Alternate Fuel**

Propane may be used as the alternate fuel only in Long Island (Nassau and Suffolk) with the approval of the local municipality having jurisdiction. Long Island propane installations must be built to conform to the standards of the LP-Gas Code NFPA58 and The Fuel Gas Code of New York State.

### **27.1 Propane as a Distributed Plant Back-up Fuel**

Vaporized propane as a back-up fuel at TC sites may be connected to the natural gas lines using a manual or automatic three-way valve as described in this section. Customer shall submit to National Grid an itemized list of the BTU ratings of all gas utilization

equipment at the site.

Facilities intending to use an automatic three-way valve for fuel selection must wire the valve control to the FS/AMR outdoor controller. Wiring diagrams detailing the design of this circuit must be submitted. See Section **24.4.1** for control and monitoring requirements of automatic sites.

Facilities intending to use a manual three-way valve for fuel selection must install an alarm panel and bell to signal an operator when switching of fuels is required. The panel must be wired to the FS/AMR and designed to alert plant personnel when both switching to propane is required and back to natural gas. See Section **24.4.2** for control and monitoring requirements of semi-automatic sites.

### **27.1.2 Interconnection for Stand-by Fuels**

Where supplementary propane gas for stand-by use is connected downstream of the National Grid service meter and/or regulator, the customer shall install check valves on both the natural gas and propane piping to prevent back flow. National Grid will provide a piping diagram for location and proper installation of the check valves. A three-way valve installed to admit the stand-by supply, if of the type that completely closes one side before starting to open the other side, shall be permitted for use in place of check valves.

### **27.3 Deleted**

### **28.0 Deleted**

**29.0** Installers of dual-fuel equipment are required to contact National Grid regarding meter and service hardware location and for questions on burner gas train arrangement, support, venting, and Temperature Controlled requirements.

# Temperature controlled (T.C.) start sheet



CUSTOMER \_\_\_\_\_ ADDRESS: \_\_\_\_\_

ACCOUNT # \_\_\_\_\_

METER# \_\_\_\_\_ UNLOCK INDEX \_\_\_\_\_ SIZE CODE \_\_\_\_\_ UNLOCK DATE \_\_\_\_\_

DOES T.C. METER SUPPLY ANY STRAIGHT GAS EQUIPMWENT? YES \_\_\_\_\_ NO \_\_\_\_\_  
 IF YES, LIST EQUIPMENT: INPUTS AND IF INTERLOCKED \_\_\_\_\_

GAS USED FOR: HEATING \_\_\_\_\_ WATER HEATING \_\_\_\_\_ COOKING \_\_\_\_\_ OTHER \_\_\_\_\_

SERVICE LP \_\_\_\_\_ LP W/ BOOSTER \_\_\_\_\_ HP \_\_\_\_\_  
 IF HP, IS LOW GAS CHANGEOVER CONTROL INSTALLED? YES \_\_\_\_\_ NO \_\_\_\_\_

NUMBER OF BOILERS \_\_\_\_\_ BOILER # \_\_\_\_\_ TANK SIZE #1 \_\_\_\_\_ #2 \_\_\_\_\_ GALLONS

BOILER MFGR: \_\_\_\_\_ MODEL # \_\_\_\_\_ BOILER HORSE POWER \_\_\_\_\_

BURNER MFGR: \_\_\_\_\_ MODEL # \_\_\_\_\_ SERIAL # \_\_\_\_\_

### CONTROLS

IS M2M INSTALLED AND OPERABLE? YES \_\_\_\_\_ NO \_\_\_\_\_ IF NO, WHY \_\_\_\_\_

IS BURNER WIRED AS PER APPROVED NATIONAL GRID ELECTRICAL PRINTS  
 YES \_\_\_\_\_ NO \_\_\_\_\_ NO PRINTS \_\_\_\_\_

### OPERATION

1. DOES EQUIPMENT AUTO SWITCH TO ALTERNATE FUEL? YES \_\_\_\_\_ NO \_\_\_\_\_
2. IF SEMI-AUTOMATIC: DOES ALARM OPERATE? YES \_\_\_\_\_ NO \_\_\_\_\_
3. HAVE ALL SAFETY CONTROLS BEEN TESTED? YES \_\_\_\_\_ NO \_\_\_\_\_

GAS INPUTS	LOW	HIGH	CFH
APPLIANCE TRAIN REGULATOR SET POINT			
LEFT ON GAS FUEL CAPABLE			
LEFT ON GAS NOT DUAL FUEL CAPABLE			

### COMMENTS:

BURNER START UP PERSON AND INSTALLATION COMPANY \_\_\_\_\_

SERVICE PERSON NAME \_\_\_\_\_ ID# \_\_\_\_\_

SIGNATURE: \_\_\_\_\_ DATE: \_\_\_\_\_

RETURN TO NATIONAL GRID PROJECT MANAGER