



GAS DESIGN STANDARD METER GUARD DESIGN AND INSTALLATION ARRANGEMENT

J-95

Publication Date: 10/18/2017 Effective Date: 11/01/2017 Rev. 3

Purpose and Scope

This gas design standard (GDS) provides requirements and instructions for selecting and installing new and retrofitted gas meter guards for residential and commercial meters subject to vehicular traffic. This GDS is used during other meter set work to correct any unprotected meter sets. These meter guards protect against incidental bump damage during typical low-speed maneuvering (i.e., turning, backing, etc.). Post installation must be done in accordance with Utility Standard TD-4412S, "Preventing Damage to Underground Facilities." Always Dig Safely and call 1-800-227-2600 before digging.

General Information

1. Physical protection must be provided for any gas meter set located in one of the areas described below:

A. Type 1 Locations

(1) Within 3' of the following:

- A single-family driveway or parking area.
- A roadway, street, alley, or driveway with a curb.

(2) Within 8' of the following:

- Multi-family driveway or parking area.
- A roadway, street, alley, or driveway without a curb.

B. Type 2 Locations

(1) Within 3' of a commercial refuse container location.

(2) Within 8' of the following:

- A commercial or industrial driveway or parking area.
- A loading dock or freight handling area.

Selection and Installation

1. If a meter location is at risk of vehicular damage, protect the location with barrier posts as follows:
 - Install meter posts so that they do not obstruct vehicular traffic, inconvenience customers, or hamper gas meter maintenance and meter reading.
 - Install all utilities before installing the barrier posts.
 - Provide barrier posts on all sides of the meter set that are exposed to vehicle hazards and that are not already protected by existing structures. Final arrangement of the barriers must not allow a vehicle approaching at any angle to damage the meter set.
 - Install all posts at the same height.
2. Protection for Type 1 Locations
 - A. A 2" diameter post should be used to provide protection for meter sets in Type 1 locations. See Figures 1–4 and Tables 1–3 for installation instructions. Protect gas meter sets in residential areas using minimum 2" diameter, Schedule 40 steel posts.
3. Protection for Type 2 Locations
 - A. A 4" diameter post should be used to provide protection for meter sets in Type 2 locations. See [Figures 1–4](#) and [Tables 1–3](#) for installation instructions. Protect gas meter sets in commercial and industrial areas using concrete-filled, minimum 4" diameter, Schedule 40 steel posts.

Note: When field conditions do not permit exact compliance with these requirements, alternatives may be proposed. Alternative meter guard arrangements must sufficiently protect the meter set and ensure adequate distance for maintenance and meter reading. A meter guard may be used in conjunction with man-made barriers such as wing-walls, planters, fences, etc., to provide protection; these barriers may be 6" or higher curbs, large trees, permanently installed planters, barrier posts, fences, or other similar permanent structures.

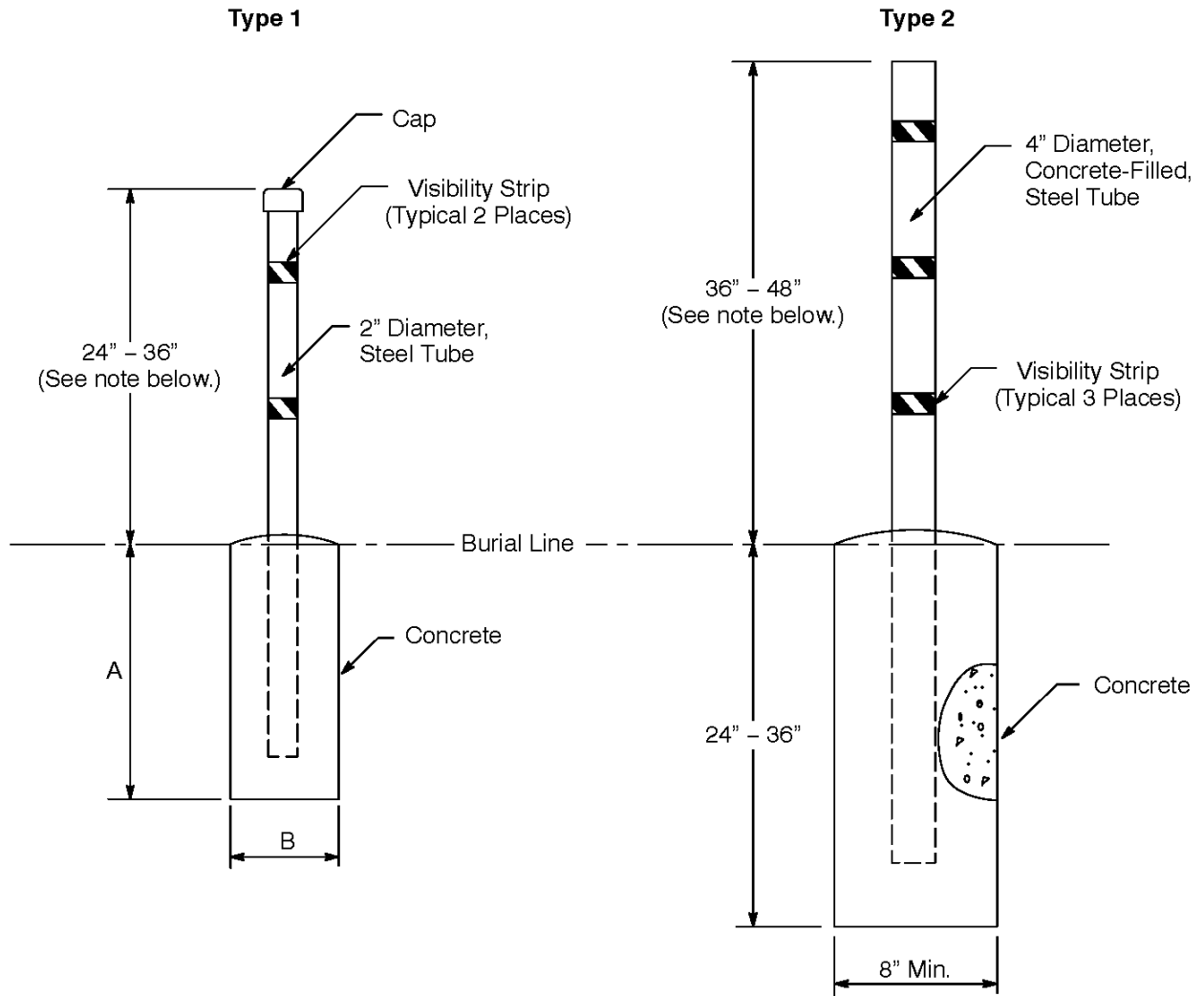
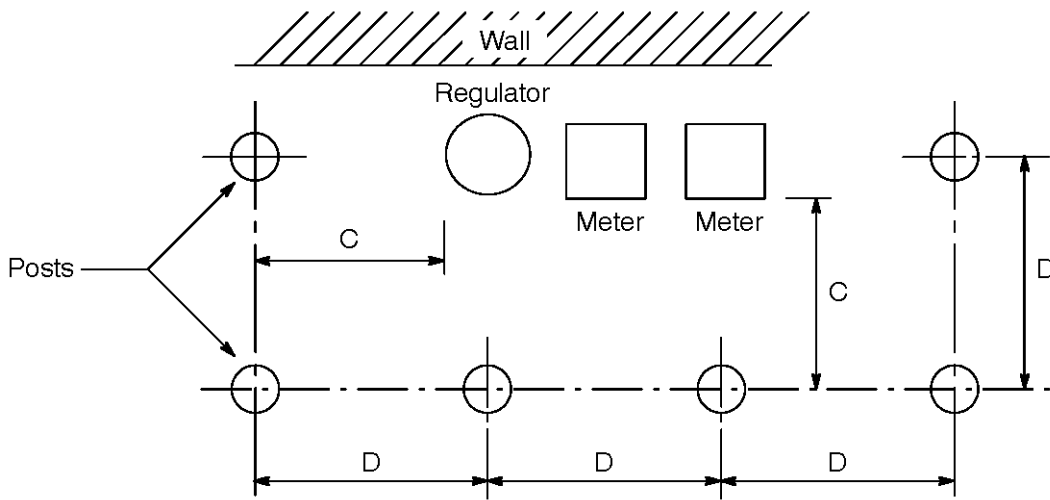

Figure 1. Post Installation

Note: Post should extend 6" above the highest point on the meter set, but not to exceed maximum height above grade.

Table 1. Dimensions for Concrete Footing

A (inches)	B (inches)
12	8
15	8
20	6



Note: The concrete footing must be at least 6" away from any point on the riser. If the post is positioned above an underground gas service, a minimum distance of 3" must be maintained between the service and the concrete footing.

Figure 2. Multiple Meters Post Arrangement

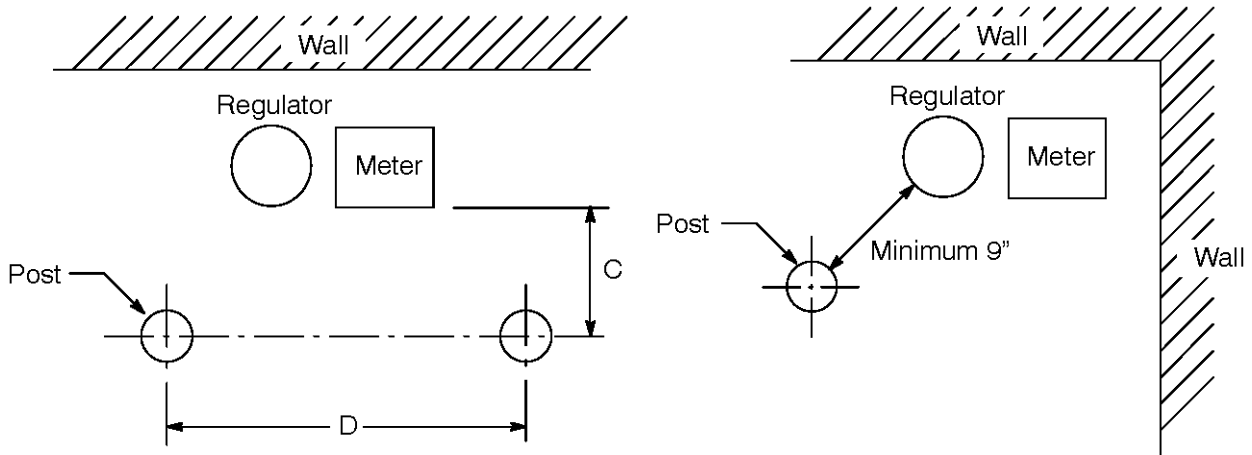

Figure 3. Single Meter Post Arrangement

Figure 4. Single Post Arrangement

Table 2. Dimensions for Post Arrangement

C ¹ (inches)	Maximum D ² (inches)
Less than 12	Space posts to prevent vehicle from contacting meter set, but leaving room for meter access and maintenance.
12	18
15	24
18	30
24	42

¹ Distance to meter or regulator.

² May not be more than 42".

Table 3. Post Materials

Description	Length	Code
2" Diameter, Schedule 40, Galvanized Pipe, with Reflective Tape 2" wide, and Steel Cap, 20 Gauge	56"	150117
4" Diameter, Schedule 40, Galvanized Pipe, with Reflective Tape 2" wide	78"	150122

Riser Protection Method

1. This method may be implemented in cases where only impact perpendicular to the structure is a threat. If there is a threat of lateral impact, install standard meter posts.
 - A. A 4-1/2" Split Steel Pipe With Mounting Flanges



WARNING

Respiratory distress can result from welding flanges onto galvanized steel if the area is not well-ventilated or an approved respirator is not worn.

- Use caution when welding flanges onto galvanized steel.
- Bolt pipe directly to the existing structure.



CAUTION

Covering the service valve makes the valve impossible to access without first removing the riser protection.

- Use to cover any portion of the riser in danger of vehicular damage, but **DO NOT** cover the service valve.
- See [Figures 5 and 6](#), and [Table 4](#), for installation instructions.

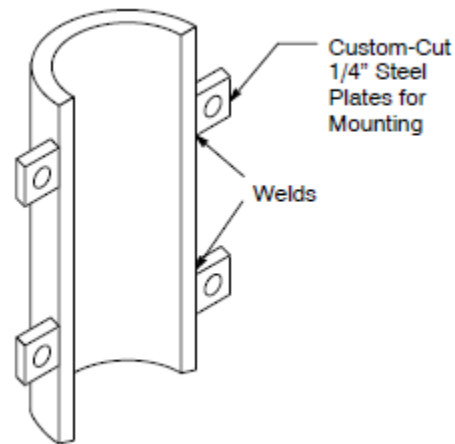

Figure 5. Riser Protection Method

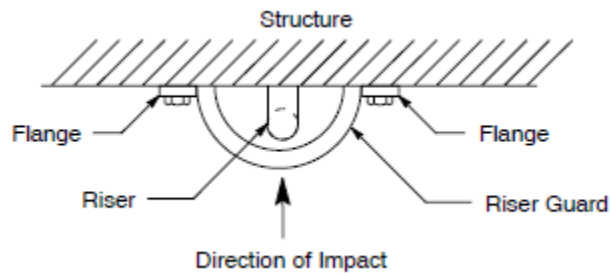

Figure 6. Riser Protected by Riser Guard

Table 4. Materials for Riser Protection

Description	Code
4-1/2" Half-Rolled Steel Pipe, Galvanized	150133

Target Audience

Design engineering, estimating, field services, maintenance and construction (M&C), gas transmission and regulation (T&R), and general construction (GC) personnel, and damage prevention process owners.

Definitions

NA

Acronyms and Abbreviations

CFR:	Code of Federal Regulations
DOT:	Department of Transportation
GC:	General Construction
GDS:	Gas Design Standard
M&C:	Maintenance and Construction
T&R:	Transmission and Regulation

Compliance Requirement/Regulatory Commitment

California Fire Code, Section (§) 603.9, "Gas meters."

Code of Federal Regulations (CFR) Title 49, Transportation, Part 192—Transportation of Natural and other Gas by Pipeline: Minimum Federal Safety Standards, §192.803, "Definitions."

49 CFR §192.353, "Customer meters and regulators: Location."

References

American Welding Society, Safety and Health Fact Sheet No. 25: Metal Fume Fever

Electric and Gas Service Requirements, "Meter Protection"

Gas Design Standard J-15, "Gas Meter Locations"

Utility Standard TD-4412S, "Preventing Damage to Underground Facilities"

Appendices

NA

Attachments

NA

Revision Notes

Revision 3 has the following changes:

1. Moved the Dig Safely message from the bottom of each page to the Purpose and Scope section.
2. Re-wrote Selection and Installation section for greater clarity.
3. In Table 3, added new descriptions of the protection posts, and removed stand-alone visibility strips and 2" end cap.

Asset Type: Distribution Mains, Distribution Services, Measurement & Control

Function: Design, Construction, Maintenance and Operation

Document Contact: [Gas Design Standard Responsibility List](#)