

RESIDENTIAL OIL-FIRED WATER HEATERS OWNER'S MANUAL INSTALLATION AND OPERATING INSTRUCTIONS

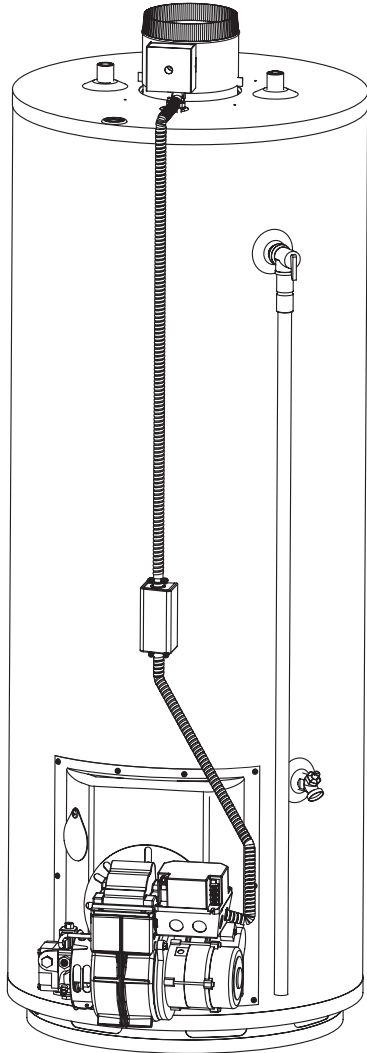

⚠ WARNING

This water heater **IS NOT** design certified for installation outdoors.

⚠ WARNING

If the information in these instructions is not entirely followed, a fire or explosion may result causing property damage, personal injury or death.

- **DO NOT STORE**, use gasoline or any other flammable vapours or liquids in the vicinity of this or any other appliance.
- **DO NOT USE** gasoline, crank case oil or oil containing gasoline.
- **DO NOT TAMPER** with the unit or controls.
- **DO NOT LEAVE** paper or rags close to the burner or the water heater.

WHAT TO DO IF YOU DETECT OIL

- Immediately call your oil supplier.

Installation and service must be performed by a qualified installer, service agency or the oil supplier.

IMPORTANT

READ THESE INSTRUCTIONS CAREFULLY BEFORE BEGINNING THE INSTALLATION. PROPER INSTALLATION WILL PROVIDE SAFE AND EFFICIENT SERVICE AND AVOID NEEDLESS EXPENSE NOT COVERED BY THE WARRANTY. READ THE PRODUCT WARRANTY CONTAINED IN THIS MANUAL AND REMEMBER TO FILL OUT AND RETURN TO THE MANUFACTURER ALL RELEVANT WARRANTY CARDS AND CERTIFICATES. SHOULD YOU HAVE ANY QUESTIONS, PLEASE CONTACT YOUR LOCAL DEALER OR REFER TO THE **GETTING SERVICE FOR YOUR WATER HEATER** SECTION OF THIS MANUAL.

SAVE THIS MANUAL FOR FUTURE REFERENCES.

For your records, write the model and serial number here:

Model # _____

Serial # _____



TABLE OF CONTENTS

Safety Information	2	Oil Filter	10
Installation Instructions	3	Oil Burner Nozzles	10
Location	3	Wiring	10
Minimum Clearances	3	Installation Instructions for Water Heaters Approved for combination Space Heating and Potable Water Heating.....	11
Combustion and Ventilation Air Supply	3	Installation Checklist	13
Requirements for Unconfined Spaces	4	Operating Instructions	14
Requirements for Confined Spaces (Indoor Combustion and Ventilation Air)	4	Lighting the Water Heater	14
Requirements for Confined Spaces (Outdoor Combustion and Indoor Ventilation Air).....	4	Lighting the Burner.....	14
Requirements for Confined Spaces (Outdoor Combustion and Ventilation Air)	4	Water Temperature Regulation	14
Air duct sizing.....	5	General Maintenance	15
Louvers and Grilles	6	Housekeeping	15
Corrosive Atmospheres	6	Annual Service by a Contractor	15
Venting	6	Routine Maintenance by the Home Owner.....	15
Chimney requirements	6	Oil Burner Air Adjustment	15
Flue piping	6	Burner Electrode	15
Draft Regulator (Barometric Damper Control)	7	Burner Primary (Safety) Control.....	15
Flue collar/Blocked Vent Switch (Installation and Operation)	7	Shutting Down the Water Heater	15
Optional Sidewall Venting (Power Vent).....	7	Condensation	15
Water Piping	8	Water Heater Tank.....	16
Temperature & Pressure-Relief Valve	9	Temperature and Pressure-Relief Valve.....	16
Pressure Build-up in a Water System	9	Venting System Inspection.....	16
Filling the Water Heater	9	Anode	16
Oil Supply.....	9	Draining the Water Heater	16
Oil Burner Installation.....	10	Getting Service for your Water Heater.....	17
		Replacement Parts	17
		Warranty	18

SAFETY INFORMATION

Your safety and the safety of others is extremely important during the installation, operation and servicing of this water heater. Many safety-related messages are provided in this manual and on your water heater. Always read and abide by all safety messages. These messages will point out the potential hazard, tell you how to reduce the risk of injury and tell you what will happen if the instructions are not followed.



This is the safety alert symbol. This symbol alerts you to potential hazards that can kill or hurt you or others. All safety messages will follow the safety alert symbol and either the word “**DANGER**” or “**WARNING**”.



DANGER

Serious injury or death can occur if you do not follow the instructions immediately.



WARNING

Serious injury or death can occur if you do not follow the instructions.



WARNING

DO NOT use this water heater if any part has been under water. Immediately call a qualified service technician to inspect the water heater and to replace any part of the control system which has been under water. Failure to follow this instruction can result in property damage, personal injury or death.

INSTALLATION INSTRUCTIONS

IMPORTANT

These instructions have been written as a guide for the proper installation and operation of your water heater and the manufacturer of this water heater will not accept any liability where these instructions have not been followed. However, for your safety and to avoid damage caused by improper installation, this water heater must be installed by a Certified Licensed Professional and meet all local codes or, in the absence of such codes, the latest edition of CAN/CSA B139, Installation for Oil Burning Equipment, in Canada, and/or the latest edition of Standard for the Installation of Oil Burning Equipment, NFPA 31, in the United States. For Mobile Home installation in Canada, all relevant Clauses of "CAN/CSA Z240MH – Manufactured Homes" must be followed. All models are CSA listed for use with No.1 (stove) and No. 2 (furnace oil).

Before proceeding with the installation instructions:

- 1) Inspect the water heater and its component parts for possible damage. **Do not** install or attempt to repair any damaged component parts. If you detect any damage, contact the dealer where the water heater was purchased or the manufacturer listed on the warranty card.
- 2) Verify that the type of oil being supplied corresponds to what is marked on the rating plate of the water heater. **DO NOT** install if the water heater or parts of the water heater have been damaged.

Location

This water heater should be located as close as possible to a chimney and to the main use of hot water. This location must not be subject to freezing temperatures. The water heater should be positioned, so that there is easy access to the oil burner, controls and drain valve. It must be located close to a suitable free-flowing floor drain. Where a floor drain is not adjacent to the water heater, a suitable drain pan must be installed under the water heater (see Figure 10). This drain pan should be at least four (4) inches (10.2 cm) larger than the diameter of the water heater, and at least one (1) inch (2.5 cm) deep, providing access to the drain valve. This pan must not restrict the flow of ventilation and combustion air. This pan must be piped to a suitable drain to prevent damage to property in the event of a water leak from the piping, the relief valve or the water heater.

Based on national building codes, the manufacturer has given the necessary instructions to prevent damage to the building. Under no circumstances is the manufacturer to be held liable for any water damage in connection with this water heater.

This water heater can be installed in a storage or residential garage if it is installed at least 18 inches (460 mm) above floor level and protected against physical damage.

⚠ WARNING

This water heater is **NOT** approved for installation on a combustible floor.

Minimum Clearances

The minimum clearances from combustible material for this water heater are: Two (2) inches (5.1 cm) from the sides and rear, twenty-four (24) inches

(61.0 cm) from the front, eighteen (18) inches (45.7 cm) from the top, and nine (9) inches (22.9 cm) from the vent pipe (eighteen (18) inches (45.7 cm) for water heaters installed in the United States) (see Figure 1).



Combustion and Ventilation Air Supply

In order for the water heater to operate properly, it must be supplied with an uninterrupted flow of clean combustion and ventilation air. The area around the water heater must always be kept clean and clear of debris. An inadequate supply of air to the water heater will produce a bright yellow burner flame causing sooting in the combustion chamber, on the burner, and in the flue tube. This can result in damage to the water heater and personal injury, if not corrected.

Combustion and ventilation air requirements are determined by where the water heater is located. Water heaters are installed in either open (unconfined) spaces or smaller (confined) spaces, such as closets or small rooms.

INSTALLATION INSTRUCTIONS

Figure 1

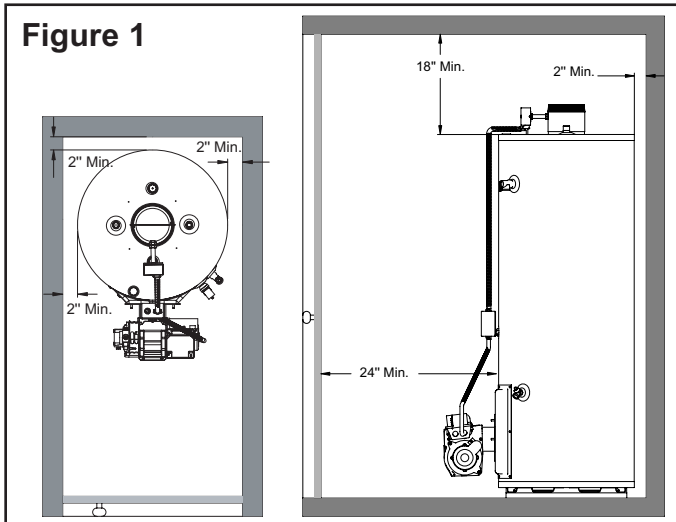

Requirements for Unconfined Spaces

Water heaters installed in unconfined spaces do not usually require outdoor air to function properly. However, if the water heater is located in an unconfined space in a building having insufficient infiltration, air for combustion and additional ventilation should be obtained from the outdoors or from spaces freely communicating with the outdoors (see Figure 2). Under these conditions, a permanent opening to the outdoors should be provided so that the total air received through this opening will be at least as much as would be admitted by openings having a total free-flow area of one (1) square inch per 5,000 BTU/h (4.4 cm²/kWh) of the total input rating of all oil-fired appliances.

Figure 2

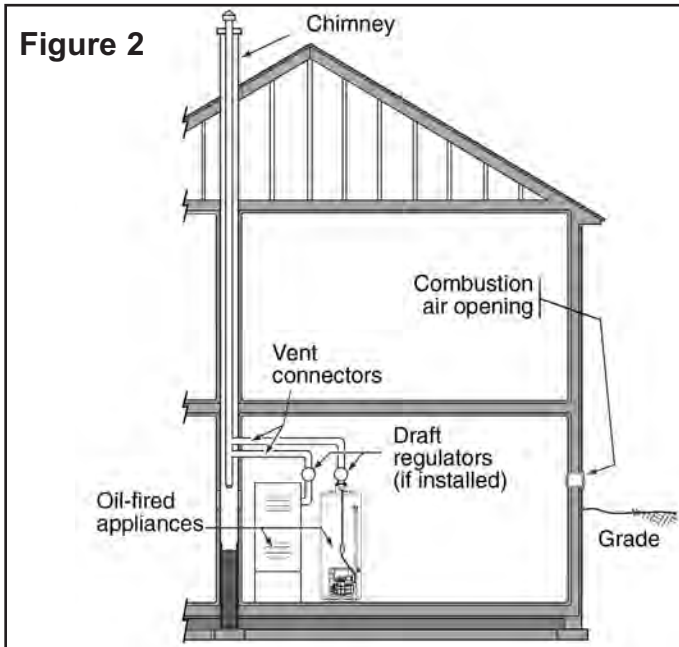

Requirements for Confined Spaces (Indoor Combustion and Ventilation Air)

A water heater that is located in a confined space and obtains all of its air for combustion and ventilation from within the conditioned space of the building should be

provided with two permanent openings, one near the top of the enclosure and another one near the bottom (see Figure 3). Each opening should have a free-flow area of not less than one (1) square inch per 1,000 BTU/h (22 cm²/kWh) of the total input rating of all oil-fired appliances in the enclosure, freely communicating with interior areas that have in turn adequate infiltration from the outdoors.

Figure 3

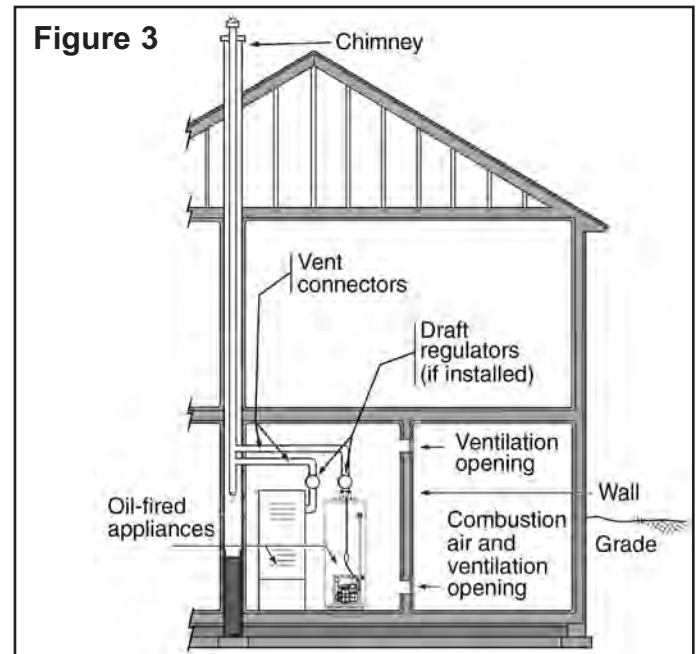

Requirements for Confined Spaces (Outdoor Combustion and Indoor Ventilation Air)

A water heater that is located in a confined space and that obtains its combustion air from outdoors and ventilation air from within the conditioned space of the building should be provided with two permanent openings, one near the top of the enclosure and another one near the bottom (see Figures 4 and 5). Each opening should have a free-flow area of not less than one (1) square inch per 1,000 BTU/h (22 cm²/kWh) of the total input rating of all oil-fired appliances in the enclosure, freely communicating with interior areas that have in turn adequate infiltration from the outdoors. A combustion air supply opening to the outdoors should be provided so that the total air received through the opening will be at least as much as would be admitted by openings having a total free-flow area of one (1) square inch per 5,000 BTU/h (4.4 cm²/kWh) of the total input rating of all oil-fired appliances in the enclosure.

Requirements for Confined Spaces (Outdoor Combustion and Ventilation Air)

A water heater that is located in a confined space and that obtains all of its air for combustion and ventilation from outside the building shall be provided with

INSTALLATION INSTRUCTIONS

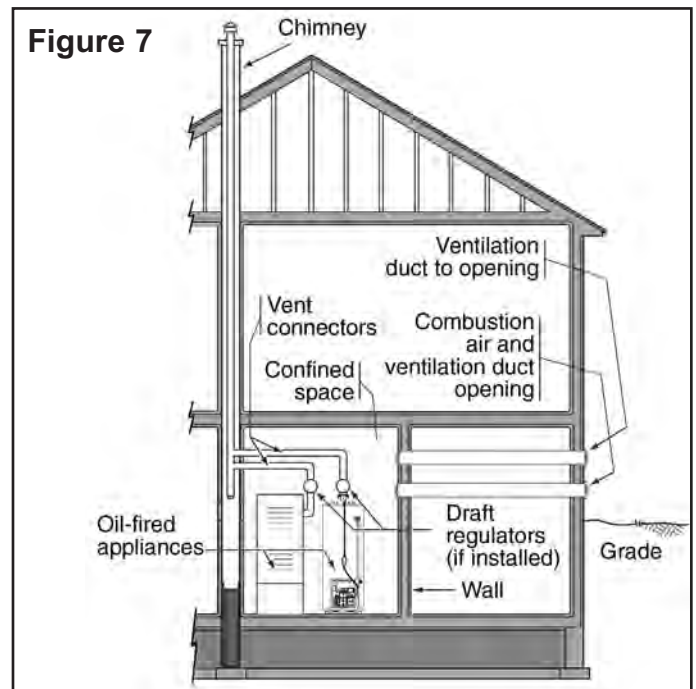
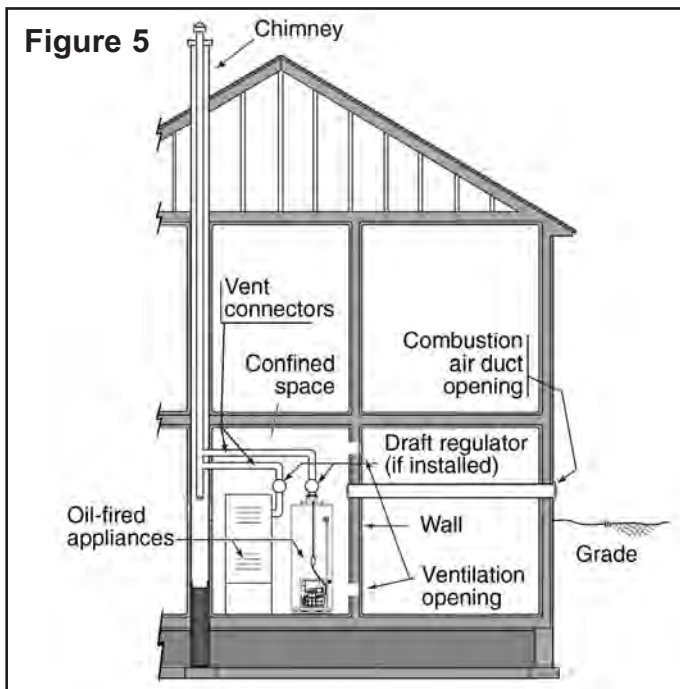
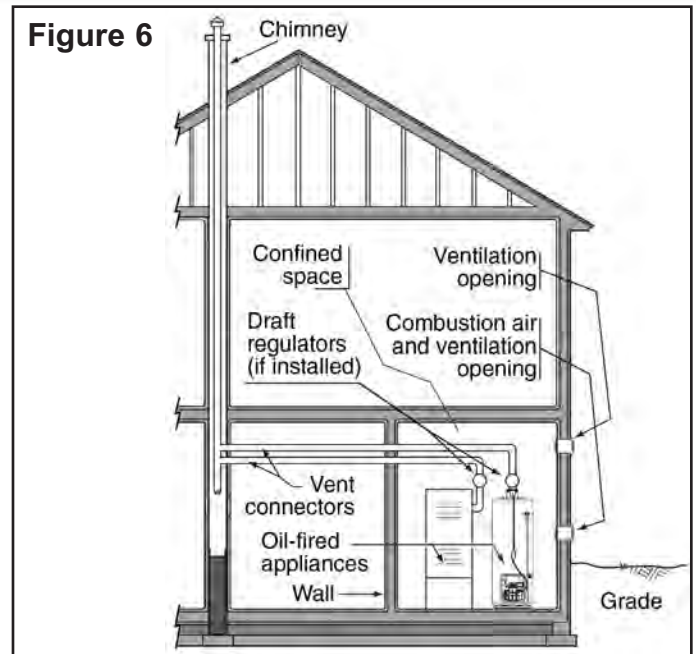
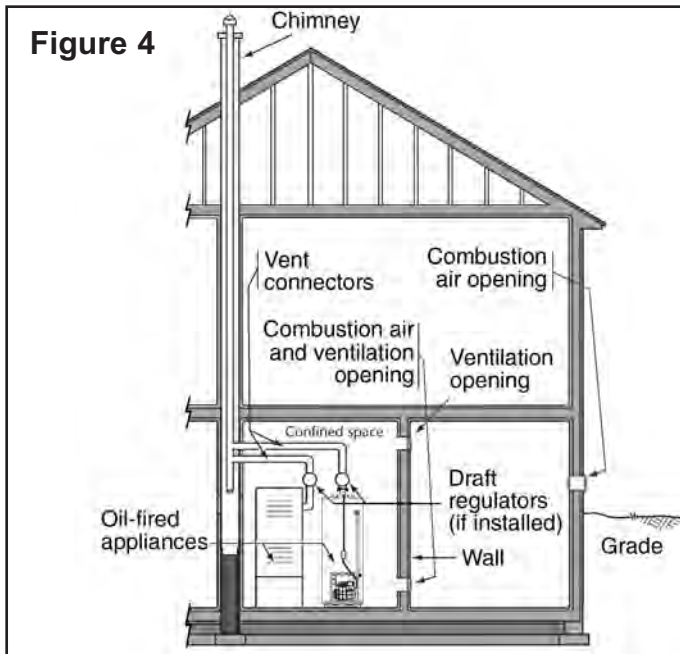

two permanent openings, one near the top of the enclosure and another one near the bottom (**see Figures 6 and 7**). Each opening shall communicate directly or by means of ducts with the outdoors or to such spaces (such as a crawl space) that freely communicate with the outdoors and shall be sized in accordance with the instructions in the section **Air Duct Sizing**.

Air Duct Sizing

The air duct requirements should be met by one of the following methods:

(a) vertical duct(s) with a free-flow area of not less than one (1) square inch per 4,000 BTU/h (5.5 cm²/kWh) of the total input rating of all oil-fired appliances in the enclosure;

(b) horizontal duct(s), as shown in **Figure 7**, with an equivalent length of less than 50 ft (15 m), having a free-flow area of not less than one (1) square inch per 2,000 BTU/h (11 cm²/kWh) of the total input of all oil-fired appliances in the enclosure; and

(c) air openings that communicate directly with the outdoors, as shown in **Figure 6**, having a free-flow area of not less than one (1) square inch per 4,000 BTU/h (5.5 cm²/kWh) of the total input rating of all oil-fired appliances in the enclosure.

Note: Duct runs that are primarily horizontal and that have an equivalent length greater than 50 ft (15 m) should be sized larger as required to provide the same airflow as would be provided by the requirements of Item (b).

INSTALLATION INSTRUCTIONS

Louvers and Grilles

In calculating free area for ventilation and combustion air supply openings, consideration must be given to the blocking effect of louvers, grilles or screens protecting the openings. Screens must not be smaller than 1/4 inch (6.4 mm) mesh. If the free area through a particular design of louver or grille is known, it should be used in calculating the size of opening required to provide the free area specified. If the design and free area is not known, it may be assumed that wood louvers and grilles will allow 20-25% free area and metal louvers and grilles will allow 60-75% free area. Louvers and grilles must be installed in the open position or interconnected with the water heater so that they are opened automatically during water heater operation.

Corrosive Atmospheres

If this water heater is to be installed in a beauty shop, barber shop, photo processing lab, dry cleaning establishment, a building with an indoor pool or near a chemical storage area, it is imperative that the combustion and ventilation air be drawn from outside these areas. These particular environments contain products such as aerosol sprays, detergents, bleaches, cleaning solvents, refrigerants, and other volatile compounds that, in addition to being highly flammable, become highly corrosive acid compounds when burned. Exposure to such compounds can be hazardous and lead to premature product failure. **Should the water heater fail, due to exposure to such a corrosive atmosphere, the warranty is void.**

Venting

DANGER

When installing the venting system, make sure to follow all local codes or, in the absence of such codes, the latest edition of the CAN/CSA B139, Installation for Oil Burning Equipment, in Canada, and/or the latest edition of Standard for the Installation of Oil Burning Equipment, NFPA 31, in the United States. Never operate the water heater unless it is properly ventilated to the outdoors and has adequate air supply for proper operation. Failure to properly install the venting system could result in property damage, personal injury or death.

Chimney Requirements

If this water heater is operated with a burner designed for natural draft venting, it must be connected to a vertical chimney. The chimney must be properly constructed and sized, clean and free of soot, creosote and obstructions, able to generate suf-

ficient draft to evacuate the products of combustion outdoors and be lined with a tile or metal liner. Inspect the chimney and make any repairs necessary before installing the water heater.

To prevent downdrafts, the chimney flue should extend at least three (3) feet (1 m) above the highest point at which the chimney comes in contact with the roof and not less than two (2) feet (0.6 m) above the highest roof surface or structure within ten (10) feet (3 m) of the chimney on a horizontal plane perpendicular to the chimney. Not more than four (4) inches (100 mm) of chimney flue above the top of the chimney cap should be considered in computing this height (see Figure 8). Increase the cross-sectional area and height of the chimney at least 4% per 1,000 feet (305 m) above sea level.

WARNING

Failure to properly inspect and repair the chimney could result in property damage, personal injury or death.

Flue Piping

Before installing the flue piping, make sure that the venting system layout has been properly planned. Make sure that the flue baffle has been installed in the flue tube. If the baffle is not present, immediately contact the dealer where the water heater was purchased. **NEVER** operate the water heater without the flue baffle installed. Verify that the location of the water heater and the venting system respects all clearances from combustible materials (see Figure 1).

The length of flue pipe to vent this water heater should be as short as possible with horizontal runs sloping upward towards the chimney at a rate of at least one-quarter (1/4) inch per foot (21 mm/m). Long horizontal runs of flue pipe, sharp turns and other construction features that could create excessive resistance to the flow of flue gas should be avoided. The flue pipe must not be smaller in cross sectional area than the flue collar on the water heater. The flue pipe must not pass through any floor or ceiling, but may pass through a wall where suitable fire protection provisions have been installed. The flue pipe should connect to the chimney such that it extends into, and terminates flush with, the inside surface of the chimney liner. The joint between the flue pipe and the chimney liner should be sealed and all unused chimney opening should be closed.

INSTALLATION INSTRUCTIONS

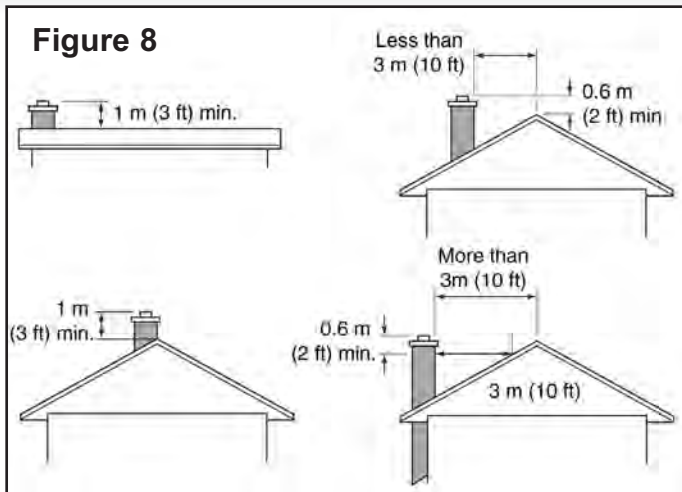

Figure 8

Draft Regulator (Barometric Damper Control)

This device is used for conventional chimney venting only. It automatically maintains a constant negative pressure in the chimney to obtain maximum efficiency. It ensures that proper pressures are not exceeded. If the chimney does not develop sufficient draft, the draft control cannot function properly. When installed, the draft regulator should be located in the same room or enclosure as the water heater and not interfere with the supply of combustion air to the oil burner.

⚠ WARNING

The water heater must be connected to a flue having sufficient draft at all times to ensure safe and proper operation of the appliance. The flue outlet pressure (measured between the water heater and draft regulator) should be set to -0.02 inches w.c. Failure to provide sufficient draft for this water heater could result in property damage, personal injury or death.

Flue Collar/Blocked Vent Switch Assembly (Installation and Operation)

This water heater has been shipped from the factory with a flue collar/blocked vent switch assembly. This switch is designed to detect flue gas spillage due to a blocked flue, continuous down drafting or inadequate draft condition.

⚠ WARNING

All wiring must be installed by a qualified installer in accordance with all local codes or, in the absence of such codes, the latest edition of the CSA C22.1, Canadian Electrical Code, in Canada, and/or the latest edition of the National Electrical Code, NFPA 70, in the United States. Before installing the switch, remember to **DISCONNECT THE POWER SUPPLY** to the water heater. Failure to follow these instructions can result in property damage, personal injury or death.

Installation:

- 1) Install the pre-assembled flue collar/blocked vent switch assembly over the flue outlet on the water heater (**see Figure 9**).
- 2) Wire the switch to the aquastat on the water heater (**see wiring diagram in Figure 11**).
- 3) Install the vent pipe onto the flue collar and secure it using sheet metal screws (not supplied).

Operation:

With the switch wired to the aquastat circuit, it will shut down the burner once it senses the spillage of hot flue gas. The switch will not allow the burner to restart until it has been manually reset. In order to manually reset the switch:

- 1) Wait for the vent pipe to cool down.
- 2) Insert the end of a pencil or square head screw driver into the opening for the reset (**see Figure 9**) and depress the red reset button.

Optional Sidewall Venting (Power Vent)

This water heater is approved in Canada for use with the Tjerlund SS1C side shot power venter and in the United States with the Tjerlund SS1 side shot power venter. This power vent kit is available through major HVAC supply companies. Technical support is offered by Tjerlund, not by the manufacturer of this water heater.

⚠ WARNING

When the installation is complete, visually inspect the venting system to make sure that all joints are properly connected and all instructions have been followed. Failure to properly install the venting system could result in property damage, personal injury or death.

INSTALLATION INSTRUCTIONS

Figure 9

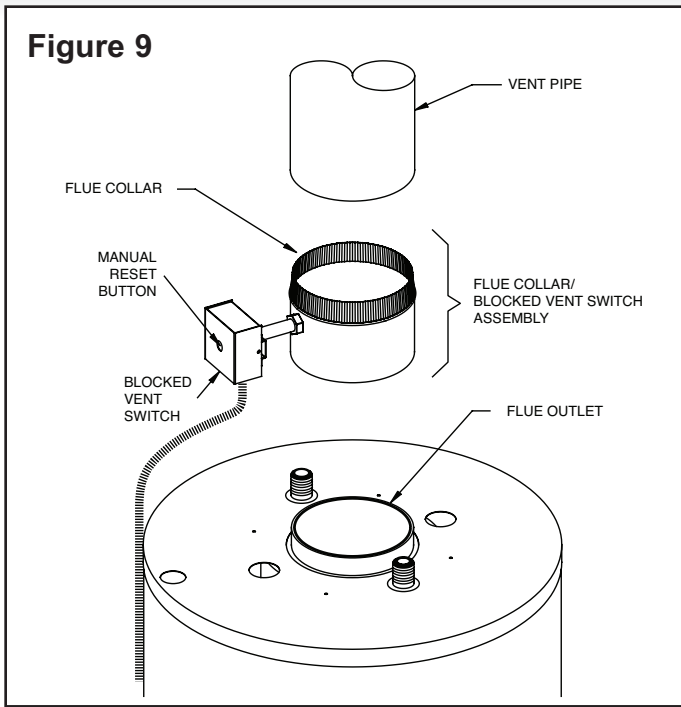

3/4" N.P.T. male thread. Make sure that the dip-tube is installed in the cold water inlet. Install a shut-off valve close to the water heater in the cold water line. It is recommended that unions be installed in the cold and hot water lines so that the water heater can be easily disconnected, if servicing is required.

When assembling the hot and cold piping, use a good food grade of pipe joint compound and ensure all fittings are tight. It is imperative that open flame is not applied to the inlet and outlet fittings, as heat will damage or destroy the plastic-lined fittings. This will result in premature failure of the fittings, which is not covered by the warranty.

Water Piping

Refer to **Figure 10** for a typical installation. Use of this layout should provide a trouble-free installation for the life of the water heater. Before making the plumbing connections, locate the COLD water inlet and the HOT water outlet. These fittings are both

Figure 10

- | | |
|---|--------------------------------------|
| 1) Flue collar/blocked vent switch assembly | 11) Oil burner |
| 2) Draft regulator | 12) Drain pan |
| 3) Sealant | 13) Free-flowing floor drain |
| 4) Cold water supply manual shut-off valve | 14) Observation port |
| 5) Expansion tank | 15) Aquastat |
| 6) Union | 16) Oil filter |
| 7) Cold water inlet | 17) Oil supply manual shut-off valve |
| 8) Temperature & pressure-relief valve | 18) Oil tank |
| 9) Overflow tube | 19) Dip tube |
| 10) Drain valve | 20) Hot water outlet |
| | 21) Union |
| | 22) Service switch |

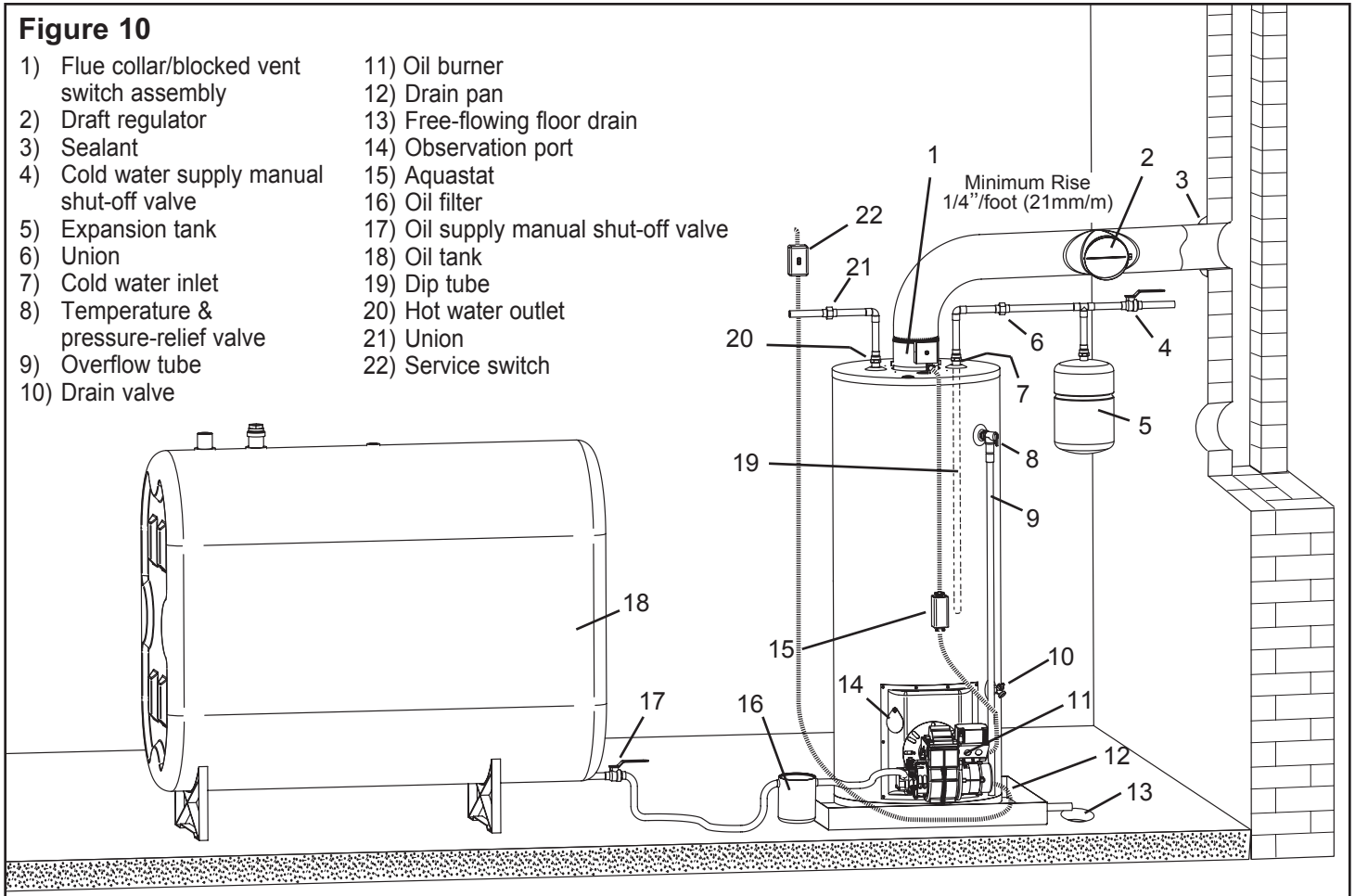

INSTALLATION INSTRUCTIONS

Temperature and Pressure-Relief Valve

WARNING

DO NOT plug the temperature and pressure-relief valve or its discharge line. **DO NOT** remove the relief valve. Make sure the relief valve is properly sized for the water heater. If the relief valve continuously discharges water, call a qualified service technician to correct the problem. Failure to follow these instructions can result in property damage, personal injury or death.

To protect from excessive pressure and/or temperature, the manufacturer has installed a temperature and pressure-relief valve that meets with the requirements of the Standard for Relief Valves and Automatic Gas Shut-Off Devices for Hot Water Supply Systems, CSA 4.4, in Canada, and ANSI Z21.22, in the United States. This relief valve has a maximum set pressure that does not exceed the hydrostatic working pressure of the water heater (150 psi = 1,035 kPa) and a BTU/h rating equal to or greater than the input rating, as shown on the water heater rating plate. It should never be plugged or removed from the opening marked for it on the water heater.

If this relief valve needs to be replaced, use only a new temperature and pressure-relief valve. Never install an old or existing relief valve, as it may be damaged or inadequate for the working requirements of the new water heater. This new relief valve must meet with all local codes or, at a minimum, the requirements listed above. Never install any other type of valves between the relief valve and the water heater.

A discharge line must be installed into the relief valve.

The discharge line:

- Must not be smaller than the outlet pipe size of the relief valve.
- Must not terminate less than six (6) inches (15.2 cm) and not more than twelve (12) inches (30.5 cm) above a floor drain.
- Must not be restricted in any way. Do not thread, cap or in any way restrict the end of this outlet.
- Must be of a material capable of withstanding 210°F (99°C) without distortion.
- Must be installed to allow complete drainage of the relief valve and discharge line.
- Must terminate at an adequate free-flowing drain.

Pressure Build-up in a Water System

When the water heater operates, the heated water expands creating a pressure build-up. This is a

natural function and is one of the reasons for installing a temperature and pressure-relief valve. If the cold water supply line has a built-in water meter, check valve or pressure-reducing valve, a suitable expansion tank must be installed to prevent pressure build-up or water hammer effect. Otherwise, the warranty will be void (**see Figure 10**). An indication of pressure build-up is frequent discharges of water from the relief valve. If the relief valve discharges water on a continual basis, it may indicate a malfunction of the relief valve and a qualified service technician must be called to have the system checked and the problem corrected.

Filling the Water Heater

WARNING

NEVER operate the water heater unless it is completely filled with water. Failure to follow this instruction can result in premature failure of the water heater that is not covered by the warranty.

Check that all of the water piping connections have been made. To fill the water heater:

- 1) Make sure that the water heater drain valve is closed by inserting a flat head screwdriver into the slot on the head of the drain valve and turning the knob clockwise .
- 2) Open the cold water supply manual shut-off valve. This valve must remain open, as long as the water heater is in use. Never operate the water heater with the cold water supply manual shut-off valve closed.
- 3) To make sure the water heater is completely filled with water, open hot water faucets to let the air out of the water heater and plumbing system. Leave the faucets open until a constant flow of water is obtained.
- 4) Check all of the plumbing connections to make sure there are no leaks.

Oil Supply

The entire fuel system should be installed in accordance with all local codes or, in the absence of such codes, the latest edition of the CAN/CSA B139, Installation for Oil Burning Equipment, in Canada, and/or the latest edition of the Installation of Oil Burning Equipment, NFPA 31, in the United States. Use only approved fuel oil tanks, piping, fittings, oil filters and any other fuel handling components. Install the oil filter as close to the burner as possible. For further details of the oil supply tank and piping requirements, please refer to the instructions and illustrations that come with the burner. If the water

INSTALLATION INSTRUCTIONS

heater is installed using a float valve between the oil supply tank and the burner, and the supply tank is over nine (9)-gallon capacity, a valve operated by a fusible link shall be installed in the fuel line adjacent to and upstream from the float valve.

Oil Burner Installation

WARNING

The installation of the oil burner must be performed by a qualified Oil Burner Technician. Before installing the oil burner, check the alignment between the burner and the combustion chamber. It is possible for the combustion chamber to shift if it is subjected to rough handling during transit. The end cone of the air tube must be centered to the accommodating passage provided in the design of the combustion chamber. Adjust as necessary. Failure to follow these instructions can result in property damage, personal injury or death.

The installation of the oil burner must be in accordance with all local codes or, in the absence of such codes, the latest edition of the CAN/CSA B139, Installation for Oil Burning Equipment, in Canada, and/or the latest edition of the standard for Installation of Oil Burning Equipment, NFPA 31 in the United States.

Oil Filter

All fuel systems should include an oil filter between the fuel oil storage tank and the oil burner. When using an oil burner nozzle smaller than 0.75, install an additional 10 micron or better filter as close as possible to the oil burner.

Oil Burner Nozzles

The OG32 water heater is certified for multiple firing rates, ranging from 82,000 to 103,000 BTU/h. The OG50 models are certified for multiple firing rates, ranging from 97,000 to input 117,000 BTU/h. Refer to the water heater rating plate or Table 1 to determine the proper burner settings.

Table 1

OIL INPUT			
Water Heater Model No.	Burner Model No. Designation	Blast Tube Insertion	Nozzle, Firing Rate @ psi
OG32	Beckett AF	4 3/4"	0,60 - 70°A 82 000 BTU @ 100 psi
		4 3/4"	0,65 - 70°A 90 000 BTU @ 100 psi
		4 3/4"	0,75 - 70°A 103 000 BTU @ 100 psi
OG32	Beckett AF	4 3/4"	0,70 - 70°A 97 000 BTU @ 100 psi
		4 3/4"	0,75 - 70°A 103 000 BTU @ 100 psi
		4 3/4"	0,85 - 70°A 117 000 BTU @ 100 psi

Wiring

WARNING

This water heater uses an external electrical source for power. It must be electrically grounded in accordance with all local codes or, in the absence of such codes, the latest edition of the CSA C22.1 Canadian Electrical Code, in Canada, and/or the latest edition of the National Electrical Code, NFPA 70, in the United States. Failure to properly ground this water heater can result in property damage, personal injury or death.

This water heater is factory wired and requires minimal field wiring. The water heater should be wired to a separate and dedicated circuit in the main electrical panel. Although a suitably located circuit breaker can be used as a service switch, a separate service switch is advisable. The service switch is necessary if reaching the circuit breaker involves becoming close to the water heater or if the water heater is located between the circuit breaker and the means of entry to the furnace room. The water heater switch (service switch) should be clearly marked, installed in an easily accessible area between the water heater and furnace room entry, and be located in such a manner to reduce the likelihood that it would be mistaken as a light switch or similar device (**see Figure 10**). The power requirement is 120VAC, 60Hz.

Before lighting your water heater, check that all of the wires have been installed correctly (**see Figure 11**). Make sure that none of the wires are grounded, have split, or are broken. Verify that all wiring connections are properly secured, as there is a possibility that they have become loose during transport. If any of the original wiring needs replacing, use only 18AWG-type, or greater wire that is approved for 221°F (105°C).

INSTALLATION INSTRUCTIONS

Installation Instructions for Water Heaters Approved for combination Space Heating and Potable Water Heating

When using a water heater for combination space and potable water heating, the instructions provided in this manual and with the air-handling unit must be respected and, in particular, the following:

- 1) All piping and components that are used in the system must be of a nonferrous type suitable for potable water. This also applies to any sealant used.
- 2) When used as a dual purpose water heater, it must not be connected to any system that has been previously used for non-potable water heating. This includes any piping because, in all probability, existing piping would have been, in the past, treated with chemicals for cleaning or sealing the system.
- 3) If this water heater is to be used for space heating, make sure that all safety codes are respected. Pay special attention to safety valve pressure and expansion tanks.

Figure 11

Electrical Wiring Diagram For White-Rodgers Aquastat
Model 11B76

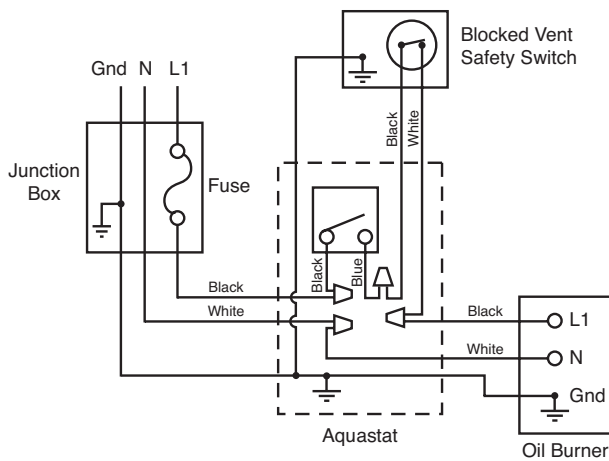

Electrical Wiring Diagram For Honeywell Aquastat
Model L4006G

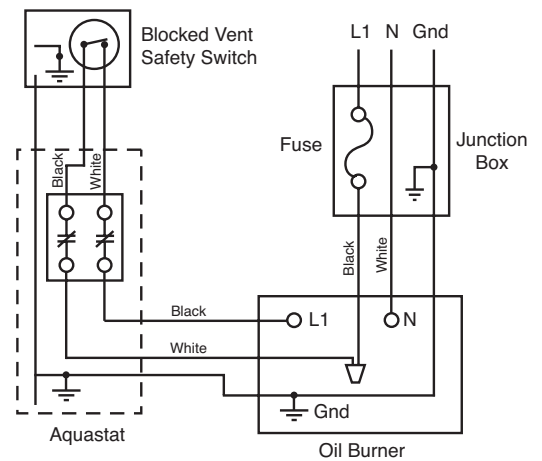

Electrical Wiring Diagram For White-Rodgers Aquastat
Model 11C30

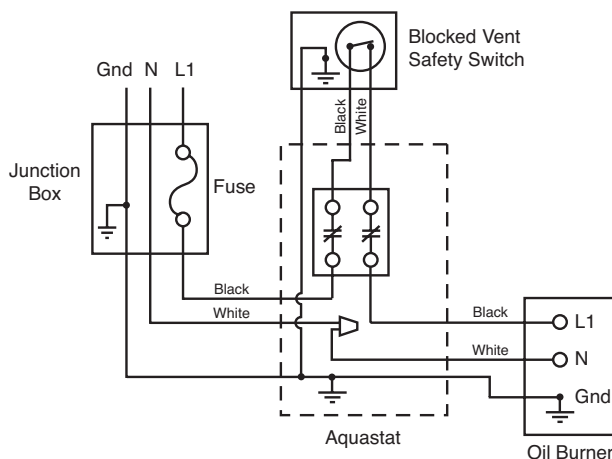

Electrical Wiring Diagram For Honeywell Aquastat
Model L4081A

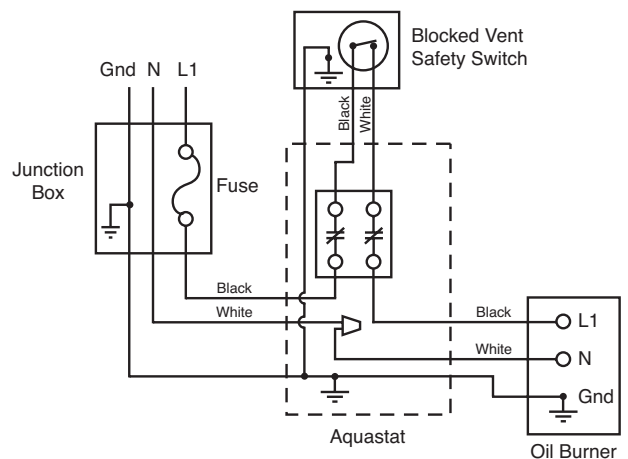

INSTALLATION INSTRUCTIONS

- 4) Do not use toxic chemicals to clean the potable water heating system.
- 5) Where water temperature in excess of 140°F (60°C) is required for a space heating application, a mixing valve must be installed in the potable side of the system. This will temper the water and reduce the risk of scalding.
- 6) If the incoming water line to the heater is equipped with a check valve, water meter or pressure-reducing valve, an expansion tank must be installed in the system. This will prevent weeping from the water heater relief valve and premature failure of the heater due to expansion of the water during the heating cycle.
- 7) Before acquisition of a water heater for space heating application, it is necessary to have the area of intended use sized by a qualified technician. This will ensure that an adequate water heating capacity will be available for both heating and potable water supply, and that the application will meet with all local codes and public utility requirements.

Note: It is good practice to oversize the water heater, to ensure that all of the potential hot water requirements are available.

Figure 12

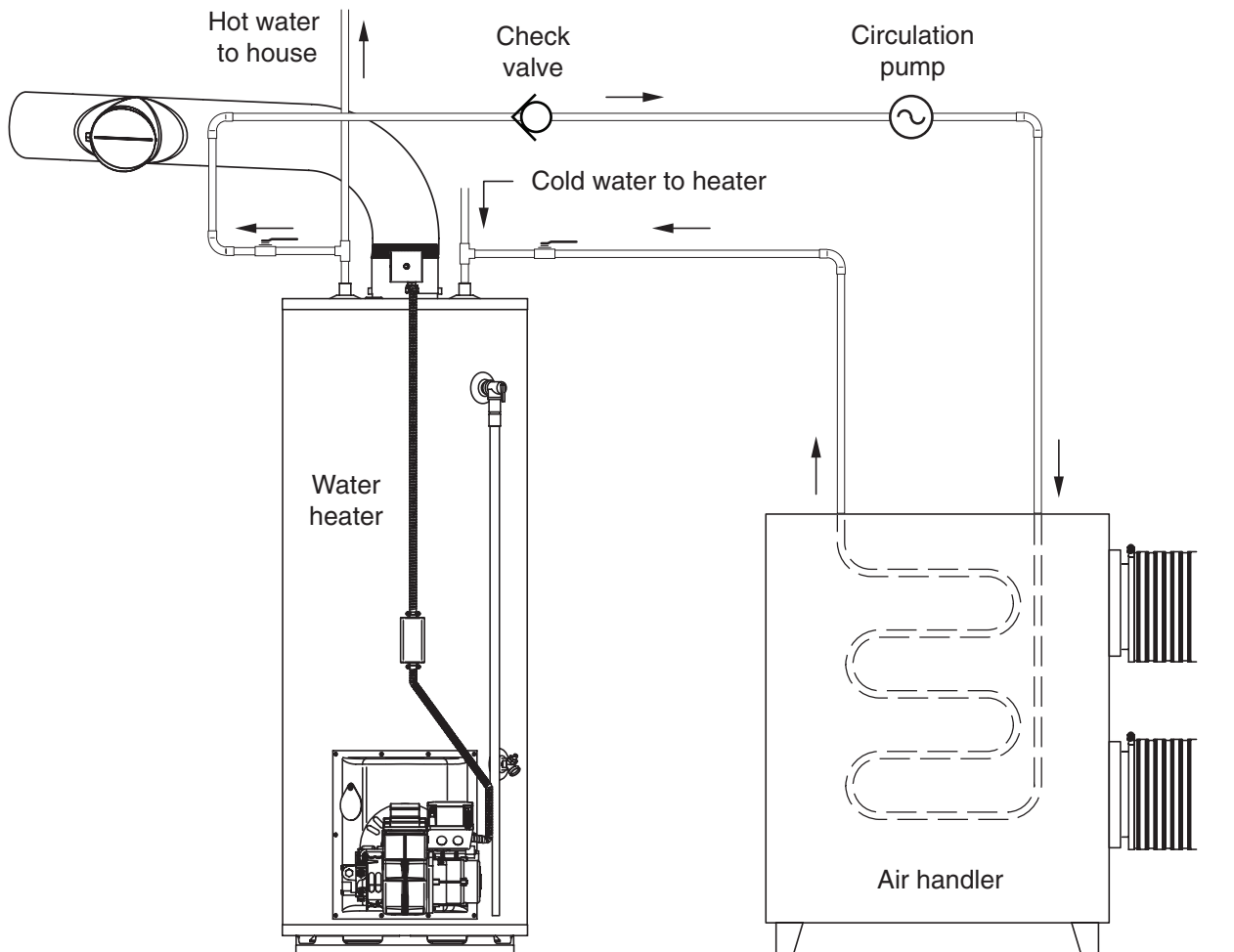

INSTALLATION INSTRUCTIONS

Installation Checklist

Location

- Is the water heater located within the venting requirements and close to the main use of hot water? ...
- Is the water heater protected from freezing temperatures?
- Has a drain pan been installed and piped to a free-flowing drain?
- Is the oil burner accessible for servicing?
- Have clearances from combustible materials been observed?.....

Combustion and Ventilation Air Supply

- Is the area around the water heater clean and properly ventilated?.....
- Is the fresh air supply free of corrosive elements and flammable vapours?.....
- Does the water heater have access to enough fresh combustion air?.....
- Have the fresh air openings been sized correctly and
has consideration been given to the blocking effect of louvers and grilles?.....

Venting

- Is the flue baffle installed in the flue tube?.....
- Has the water heater been vented separately from all other oil-fired appliances?.....
- Have all horizontal runs of vent pipe been installed with a minimum rise of
1/4 inch per foot (21 mm/m) of run?.....

Water Piping

- Is the dip-tube installed in the cold water inlet?
- Has a temperature and pressure-relief valve been installed?.....
- Does this valve have a discharge line installed, and is it piped to a free-flowing drain?.....
- Have all the plumbing connections been properly installed, and are they leak-free?.....
- Is the water heater completely filled with water?

Oil Supply

- Does the oil piping conform to the recommendations of the oil supply company?.....
- Has the oil piping been leak tested?

Wiring

- Has the wiring been properly installed?
- Have the electrical connections been checked, and are they secure?.....
- Is the water heater electrically grounded?

INSTALLATION INSTRUCTIONS



Lighting the Water Heater

Before lighting or re-lighting your water heater, make sure that you have read and understood all of the instructions and warnings in this manual and on your water

heater. If you have any questions about lighting your water heater, immediately contact a qualified installer, service agency or the oil supplier.

WARNING

Do not light this water heater if:

- It is not full of water.
- Excess oil has accumulated.
- The combustion chamber is hot.
- Gasoline or other flammable vapours and liquids have been stored in the vicinity of the water heater.

Failure to follow these instructions can result in property damage, personal injury or death.

Lighting the Burner

Set the aquastat slightly above the tank's water temperature. The burner should start. It may be necessary to press the reset button on the primary combustion control relay. After a short period of time, the water should reach the temperature setting on the aquastat and the oil burner should stop. Adjust the aquastat setting to the desired water temperature. The water heater should be operated for a minimum of 10 to 15 minutes to reach steady state conditions before fine tuning combustion. The warm up time is ideal for testing the oil pump pressure.

Water Temperature Regulation

WARNING

The higher the setting, the greater the risk of scalding. Hot water can cause third degree burns in under one (1) second at 160°F (71°C), in five (5) seconds at 140°F (60°C) and in thirty (30) seconds at 130°F (54°C). In households where there are children, physically challenged individuals or elderly persons, mixing valves for point of use are necessary as means of reducing the scalding potential of hot water.

Once installed, the operation of this water heater will be completely automatic. The aquastat on the water heater is adjustable and will maintain the water at the desired temperature. Contact a qualified service technician for adjustment. Set the aquastat as low as possible to provide an adequate supply of hot water.



This will conserve oil and extend the life of the water heater.

When hot water is drawn from the tank in frequent short bursts, a condition known as "stacking" is created. "Stacking" is the result of increased cycling of the burner and can produce very hot water temperatures at the hot water outlet. Always remember to check the hot water coming out of any faucet with your hand before use. This will reduce the risk of scalding-related injury.

GENERAL MAINTENANCE

Housekeeping

WARNING

DO NOT store or use gasoline or any other flammable vapours or liquids around the water heater. **DO NOT** put or store any objects on the top of the water heater. Failure to follow these instructions can result in property damage, personal injury or death.

Annual Service by a Contractor

The combustion chamber is fragile. Use care when inspecting and cleaning this area. The heat exchanger flue passage and baffle should be inspected periodically and cleaned if necessary. A wire brush can be used to loosen dirt and debris on the inside surface of the flue passage and baffle. Clean out all accumulated dirt and soot with an industrial vacuum cleaner, paying close attention to the combustion chamber area.

Routine Maintenance by the Home Owner

Keep the area around the water heater clean and free of dust, lint and dirt. Make sure that all of the minimum clearances to combustible materials are being maintained. On a regular basis, you should inspect the general conditions of the water heater, watching for signs of oil leaks in the vicinity of the oil burner and soot forming on any external part of the water heater or joints of the vent pipes, etc. If any of these conditions are present, please advise your service or installation contractor. The water heater should be serviced on an annual basis by a qualified service technician.

Oil Burner Air adjustment

At the time of installation, and at least at each annual cleaning or inspection, a test for smoke density and carbon monoxide (CO) must be performed. Drill a test port in the venting between the water heater flue outlet and the draft regulator (barometric damper). It is essential for the proper operation of the water heater that this adjustment is performed with the use of combustion instruments, as a visual inspection is not sufficient. Oil-fired water heaters tend to run with shorter operating cycles and it is therefore important for the burner to be adjusted to provide a good flame. A lack of air causes "sooty" or "soft" flames, resulting in soot build-up throughout the heat exchanger passages. Excess combustion air causes a bright roaring fire and high stack temperatures resulting in poor fuel efficiency.

After the burner has been firing for 10-15 minutes, take a smoke sample with a Bacharach smoke sampler or other approved device. Then, take a

sample of the flue gases and test for CO using a combustion analyser. The smoke spot should not exceed "Trace" on the Bacharach Scale. The water heater operates most efficiently with a "Trace" smoke spot. For complete details on adjusting the air, please consult the oil burner instruction manual provided with the burner.

Burner electrode

Correct positioning of the electrode tips with respect to each other, to the fuel oil nozzle and to the rest of the burners is essential for smooth light ups and proper operation. Refer to the oil burner instructions shipped with the burner for electrode specifications.

Burner primary (safety) control

The oil burner is equipped with a primary combustion control, sometimes referred to as the burner relay or burner protector relay, which uses a light sensing device (cad cell) located in the burner housing, to monitor and control combustion. Over time, dust or combustion residuals can build up on the lens of the cad cell impairing its response to the flame. The cad cell should be checked for cleanliness and proper alignment if the primary control frequently shuts down combustion.

Shutting Down the Water Heater

WARNING

Always keep the oil supply manual shut-off valve-closed if the burner is shut down for an extended period of time

Set the aquastat to the lowest possible setting. Turn off all of the electrical power to the water heater.

Condensation

As moisture from the products of combustion comes into contact with the cold surface of the inner tank, it may condense. This situation will usually occur:

- 1) When the water heater is filled with cold water for the first time.
- 2) If the water heater has been undersized.
- 3) When large amounts of hot water are drawn from the water heater in a short period of time and the refill water is very cold.

Due to the high-efficiency rating of this oil-fired water heater, it may produce more condensation than older models. This condition is not uncommon and must never be misinterpreted as a leaking tank. It will disappear once the water becomes heated.

GENERAL MAINTENANCE

Because of the large amounts of water that can condense, it is very important that a drain pan be installed under the water heater (refer to Figure 10). Under no circumstances is the manufacturer to be held liable for any water damage in connection with this water heater. If the problem persists and water continues to drip after the water heater has heated up, check all of the plumbing connections to make sure they are not leaking.

Water Heater Tank

Drain a pail of water through the drain valve at least once a year. This will remove excess sediment from the bottom of the tank. If allowed to accumulate, this sediment will reduce the efficiency and the life of the tank.

Temperature and Pressure-Relief Valve

Manually operate the temperature and pressure-relief valve at least once a year, standing clear of the outlet to avoid being burned. Lift and release the operating lever on the valve to make it operate freely. If, after manually operating the valve, it fails to completely reset itself and continues to discharge water, replace it with a new one.

Venting System Inspection

The venting system must be thoroughly inspected once a year. Check the area where the water heater is located to make sure that there is enough clean combustion and ventilation air. Remove any possible obstructions that would prevent proper air circulation and venting. Check the venting system to make sure that all of the connections are securely fastened and that all of the joints are properly sealed. If any part of the venting system is damaged, it must be replaced by a qualified service technician.

Anode

This water heater is equipped with dual anode rods that are designed to prolong the life of the glass-lined tank. The anodes are slowly consumed, protecting the glass-lined tank from corrosion. The anodes should be checked every two (2) years. If more than half of either anode has been consumed, it should be replaced. Instructions on how to change the anodes can be obtained from the manufacturer.

The life expectancy of the water heater is reduced where a water softener is introduced to fight hard water, because the sodium salts added by a softener make this water extremely conductive. In these conditions, the anodes are consumed more rapidly and should be verified every year. In certain water conditions, the anodes will react with the

water, producing discoloured or smelly water. The most common complaint is hot water that smells like rotten eggs. This phenomenon is the result of the reaction between the anode and hydrogen sulfide gas dissolved in the water, which occurs frequently in well systems. This problem can usually be eliminated or reduced by changing the anodes to a type more suitable for these conditions (aluminum anode) and by chlorinating the water heater and plumbing system. If the problem persists, special filtration equipment may be required. Under no circumstances should the anodes be removed from the water heater on a permanent basis. **Removal of the anodes will lead to premature failure of the water heater and void the warranty.**

WARNING

Hydrogen gas can be produced in a hot water system that has not been used for a long period of time (generally two [2] weeks or more). **HYDROGEN GAS IS EXTREMELY FLAMMABLE.** It is highly recommended to open the hot water faucet in the kitchen for several minutes before you use any electrical appliances connected to the hot water system, such as a dishwasher or washing machine. If hydrogen gas is present, there will be an unusual sound, such as air escaping through the pipe, as the hot water faucet is opened. Do not smoke or introduce an open flame near the faucet when it is opened.

Draining the Water Heater

To completely drain the water heater:

- 1) Turn off the power to the water heater.
- 2) Close the oil supply manual shut-off valve.
- 3) Close the cold water supply manual shut-off valve.
- 4) Connect one end of a garden hose to the water heater drain valve and put the other next to a free-flowing drain.
- 6) Open the drain valve by inserting a flat head screwdriver into the slot on the head of the drain valve and turning the knob counterclockwise .
- 7) Open a hot water faucet to allow air into the system.

GENERAL MAINTENANCE

Getting Service for your Water Heater

If you are experiencing problems with your water heater, follow these easy steps:

For the oil burner:

Consult the oil burner owner's manual.

For the water heater:

Contact the manufacturer's Customer Service Department by e-mail at service@giantinc.com or by phone at **1-800-363-9354**. To help serve

you in a quick and efficient way, **always have the following information ready:**

- a) Model number
- b) Serial number
- c) Date of installation
- d) Where the water heater was purchased
- e) Complete address where the water heater is installed
- f) A description of the problem

REPLACEMENT PARTS

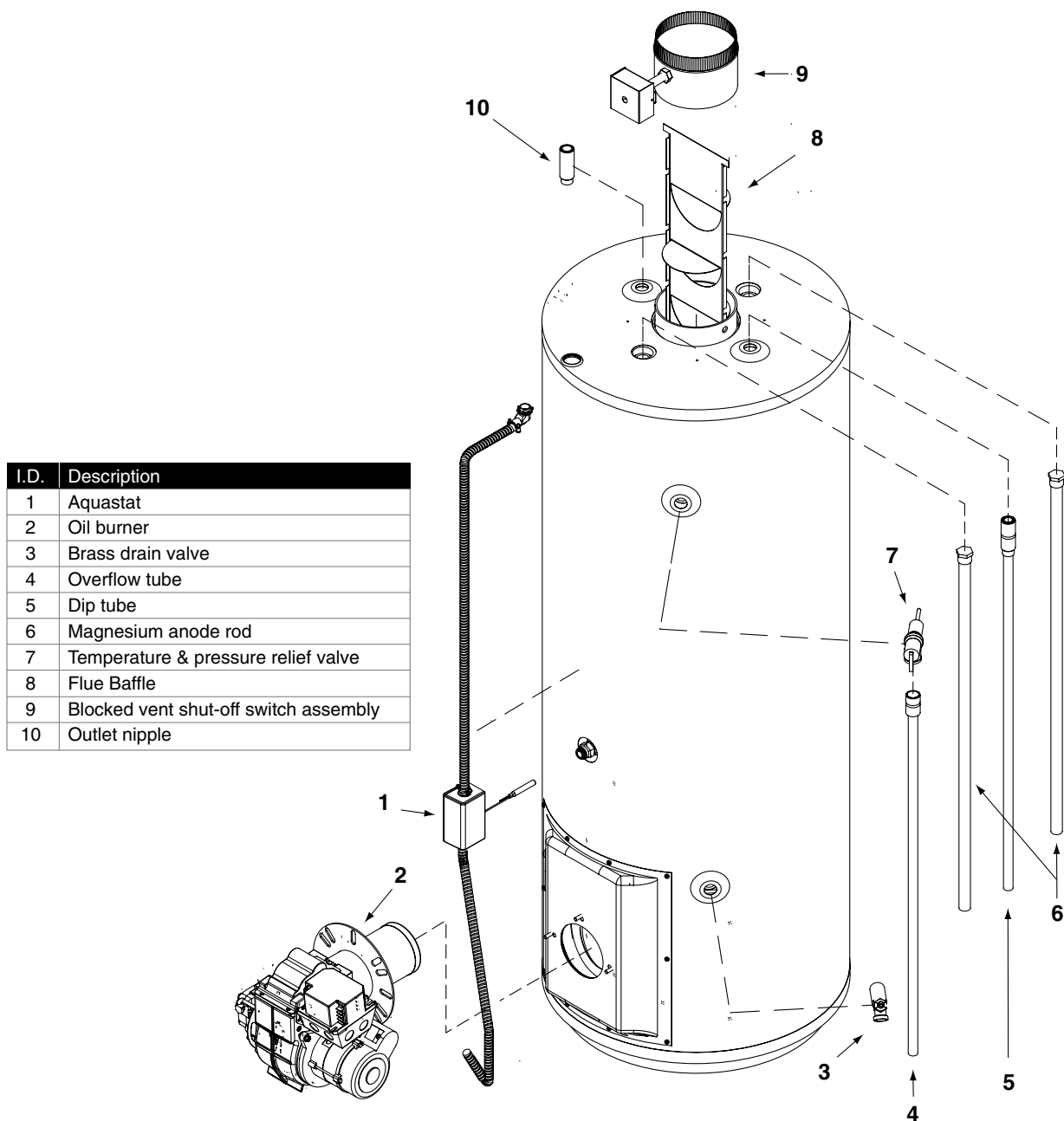

STANDARD BASIC LIMITED WARRANTY ON RESIDENTIAL OIL WATER HEATERS

GENERAL

The manufacturer warrants that, subject to verification of a warranty claim within the warranty period as described below, it will take the necessary corrective action to either repair or replace a water heater or component part which is determined to be defective in material or workmanship subject to the terms and conditions outlined in this document. Further, any replacement water heater or component part supplied under warranty will carry only the unexpired portion of the original water heater's warranty. The number of replacement water heaters is limited to one (1) per original unit purchased. If due to some extremely unusual circumstances, a replacement water heater or component part is found to be defective by our inspection & testing department, another heater or component part will be supplied to fulfill the obligation of the warranty of the original heater.

THE INNER TANK

If the inner tank fails within *SIX (6) years after the date of the original installation, a replacement water heater will be provided to the party from whom the unit was originally purchased. If the water heater is installed in other than a single family dwelling, the tank warranty is limited to ONE (1) year. If an exact replacement is not available, the manufacturer reserves the right to furnish a comparable model water heater; however, a surcharge will be applied for any additional component(s) incorporated in the replacement water heater. The warranty reply card must be completed and sent back to the manufacturer within forty-five (45) days of the installation date. If said warranty card is not returned, the date indicated on the model serial plate will prevail.

COMPONENT PARTS

If any component part is found to be defective within ONE (1) year from the date of original installation, provided said defective part is an in-house factory made piece or an original factory approved OEM piece, the manufacturer will furnish a replacement part after the receipt and testing of the part claimed to be defective.

THIS WARRANTY WILL NOT APPLY

- 1) To defects or malfunctions resulting from failure to properly install, operate, or maintain the unit in accordance with the printed instructions.
- 2) If the installation does not conform to CSA &/or ETL Standards as well as any applicable national or local building codes.
- 3) To any damage or failure caused by abuse, accident, fire, floods, freezing or other acts of God.
- 4) To any damage or failure caused by operating the heater without an approved pressure & temperature relief valve having been installed.

- 5) To any damage or failure caused by operating the heater with an empty or partially empty inner tank or sediment build-up resulting in dry firing of the heating elements.

- 6) To any damage or failure caused by utilizing the heater in conjunction with any other energy saving device or other source(s) of energy not approved by the manufacturer, or for other than use with potable water without any additives such as salt, chlorine or chemicals other than those added for the purpose of rendering the water fit to drink.

- 7) To any damage or failure caused by the removal of the anode &/or by not assuring that there is a working anode in the tank at all times. All anodes must be checked at least once every two years & replaced, if necessary.

- 8) To any damages or failure caused by having affixed to the heater any non-factory made or factory approved replacement part(s) such as elements, controls, dip-tubes, relief valves, etc.

- 9) To any damage caused by not having the water heater installed adjacent to a free flowing drain in the event of water leakage.

- 10) If the heater is operated at water temperatures exceeding the maximum setting of the operating &/or high limit control or the heater is not supplied with potable water, free to circulate at all times.

- 11) If the heater has experienced the effect of thermal expansion due to excessive pressure (exceeding 300PSI). The result of excessive pressure usually reverses the bottom of the inner tank and can occur with the addition of a pressure reducing valve &/or a check valve in the municipal water supply system in a single family dwelling.

- 12) If the heater is installed outside of Canada or the United States.

SERVICE LABOUR RESPONSIBILITY

This warranty does not cover any labour expense for service, removal, or re-installation of a replacement heater. All such expenses are your responsibility.

SHIPPING COSTS

If a water heater or component part is deemed to be replaced, the manufacturer will pay the transportation costs of the replacement unit to a convenient authorized distributor or retailer as selected by us. You must pay any local cartage including the cost of returning the replaced item to the authorized distributor or retailer from whom the replacement is coming from.

HOW TO MAKE A CLAIM

Any claim for warranty service should be made to your contractor, wholesaler or retailer from whom the water heater was purchased. In turn, said contractor, wholesaler or retailer will contact the manufacturer from whom they purchased the heater. If this procedure cannot be followed, contact any other local contractor, wholesaler or retailer handling our water heaters. Also, for warranty information you may call the manufacturer's customer service department at (514) 645-8893 or 1-800-363-9354, ext. 240. We suggest that prior to calling the factory, that you make sure to have the model number & serial number that is to be found on the outside casing of the heater. Proof of purchase showing the date, name and place of the business from whom the water heater was purchased is essential to settle any warranty claim dispute over the length of the period of installation.

If an exact replacement is not available, a current model water heater or component part with comparable operating features will be provided by the manufacturer. If government regulations or industry standards require the replacement model water heater or component part to have features not found on the defective model water heater or component part, you will be charged the difference in price associated with these required features. If you pay the difference in price for these required features, you will receive a complete new Standard Basic Limited Warranty for the replacement water heater.

MISCELLANEOUS

No one is authorized to make any other warranties on the manufacturer's behalf. Any implied warranties of any nature offered by a third party other than what is stated in this Standard Basic Limited Warranty will not be honoured. No claims for incidental or consequential damages (including damages from leakage) will be accepted. If you do not return the warranty card, a proof of purchase showing the name, date and location of the original source of purchase is a necessity to process a warranty claim. Failure to produce this documentation will result in the lesser of the warranty periods being offered. In order to avoid any confusion &/or disputes, we suggest that the warranty card be completed and mailed back no later than forty-five (45) days after installation.

EXTENDED WARRANTIES

For information on some premium quality residential gas & electric water heaters, contact your local licensed plumber or look for them at selected retailers.