

Gypsum Board Systems



09 29 00

Gold Bond® BRAND Gypsum Board Products

National Gypsum Company features a wide variety of gypsum board products and accessories including regular gypsum board, Fire-Shield fire resistant board, 1/4" High Flex Gypsum Board, 1/2" High Strength Ceiling Gypsum Board, Hi-Impact Gypsum Board, Gridstone Ceiling Boards, Gypsum Sheathing, Fire-Shield Shaftliner, Durasan Prefinished Gypsum Board, Exterior Soffit Board, and Joint Treatment products.

Our concentration isn't on building products alone, however. At the National Gypsum Research and Testing Center, we develop complete construction systems. In such systems, products are evaluated together as complete building assemblies—walls, partitions, floors and ceilings.

We have included in this section details and application instructions for many of those assemblies: Steel Frame Partitions, Steel Frame Ceilings/Furring Channels or Studs, Wood

Frame Wall and Ceilings, Gypsum Board Over Foam Insulated Masonry and Solid Laminated Partitions.

Before a National Gypsum System is released to the building industry, it is thoroughly tested, and results are correlated and charted to make it easier for the builder or specifier to match a system to their needs or to the building codes.

The drywall construction systems referred to in this catalog are designed primarily with materials manufactured by National Gypsum

Company. Substitution of any product or other brands in a tested system is not recommended.

Field installation of tested systems must be identical to laboratory installation to produce optimum performance of these systems. Performance tests are conducted in accordance with accepted national standards under controlled laboratory conditions to minimize variances and to permit comparison of test results with all types of systems, similar and dissimilar.

DESCRIPTION

Description

Core Thickness/Type Width/Edge Lengths

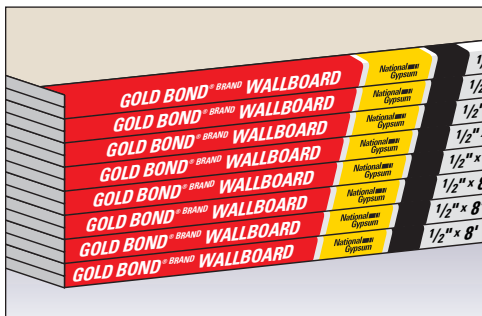

Gold Bond BRAND Gypsum Board with tapered edge permits smooth joint treatment; surface takes any decoration. Basic recommendations: 1/2" board for single layer; 3/8" board for 2-layer; 1/4" board is regular gypsum board used in remodeling and for sound control in double layer applications. Refer to page 65.

Regular	1/4" (6.3 mm)	4' (1219 mm)	6' (1828 mm) thru 16' (4876 mm)
	3/8" (9.5 mm)		
	1/2" (12.7 mm)*		
		Square or Tapered	

Note: 1/2" gypsum board available in 54" widths.

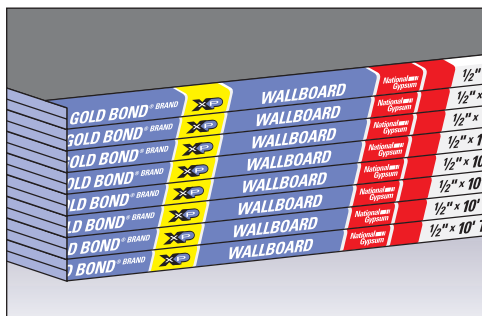

Gold Bond BRAND XP Gypsum Board is designed to provide extra protection against mold and mildew compared to standard gypsum board products. Tapered edge permits smooth joint treatment. Refer to page 70.

Regular	1/2" (12.7 mm)	4' (1219 mm)	8' (2438 mm) thru 12' (3657 mm)	
				Square
				or Tapered



Gold Bond BRAND Fire-Shield Gypsum Board is manufactured with a type X core to achieve fire resistance ratings when used in recommended systems. Refer to page 66.

Gold Bond BRAND Fire-Shield C Gypsum Board has a specially formulated type X core to achieve superior performance when used in specific fire rated assemblies. May be used in designs requiring Fire-Shield Gypsum Board (type X core). Refer to page 66.

Type X	5/8" (15.9 mm) FSW*	4' (1219 mm)	6' (1828 mm) thru 16' (4876 mm)	
				Square
				or Tapered

Type X	1/2" (12.7 mm) FSW-C	4' (1219 mm)	6' (1828 mm) thru 16' (4876 mm)	
				Square
				or Tapered

Type X	5/8" (15.9 mm) FSW-C	4' (1219 mm)	8' (2438 mm) thru 14' (4267 mm)	
				Square
				or Tapered

Note: 5/8" Fire-Shield gypsum board available in 54" widths.

* Available with Foil Backing. Refer to page 86.

Reference www.nationalgypsum.com for fire safety information.

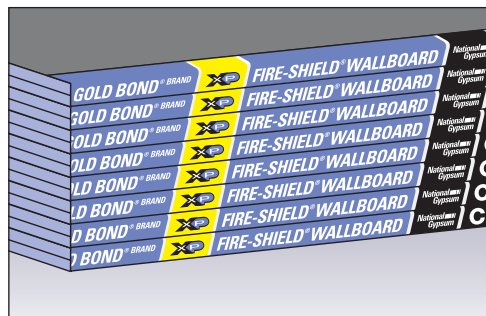

Description

Core Thickness/Type Width/Edge Lengths

Gold Bond BRAND XP Fire-Shield Gypsum Board is manufactured with a fire resistive type X gypsum core and is designed to provide extra protection against mold and mildew. Refer to page 70.

Gold Bond BRAND XP Fire-Shield C Gypsum Board has a specially formulated type X gypsum core to achieve superior fire resistance performance and is designed to provide extra protection against mold and mildew. Refer to page 70.

Type X 5/8" (15.9 mm) FSW-3	4' (1219 mm)	8' (2438 mm) thru 12' (3657 mm)
Type X 1/2" (12.7 mm) FSMR-C	4' (1219 mm)	8' (2438 mm) thru 12' (3657 mm)
Type X 5/8" (15.9 mm) FSMR-C	4' (1219 mm)	4' (1219 mm) thru 12' (3657 mm)

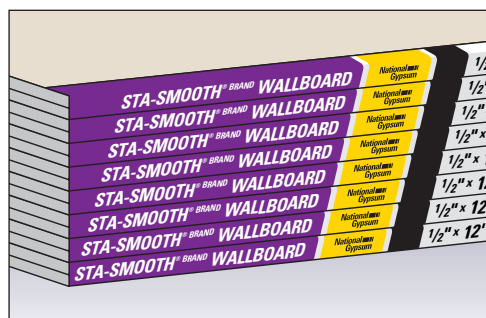

Gold Bold BRAND Sta-Smooth Gypsum Board, used with ProForm BRAND Sta-Smooth Joint Compound, forms a drywall system offering maximum joint strength. Two edge configurations provide relief on joint deformities. The round edge configuration solves joint deformity problems caused by twisted framing, damaged board edges, poor alignment and extremes in humidity and temperature. Refer to page 67.

Regular 1/2" (12.7 mm)	4' (1219 mm)	6' (1828 mm) thru 16' (4876 mm)
Type X 5/8" (15.9 mm) FSW	4' (1219 mm)	8' (2438 mm) thru 16' (4876 mm)
Type X 1/2" (12.7 mm) FSW-C	4' (1219 mm)	6' (1828 mm) thru 16' (4876 mm)

Note: 1/2" regular Sta-Smooth gypsum board available in 54" widths.



Gold Bond BRAND Kal-Kore Plaster Base is a tapered edge gypsum board plastering base having a blue absorptive face paper surface designed to permit rapid trowel application and strong bond of veneer or conventional gypsum plaster. Refer to page 45.

Regular 3/8" (9.5 mm) or 1/2" (12.7 mm)	4' (1219 mm)	8' (2438 mm) thru 16' (4876 mm)
Type X 1/2" (12.7 mm) FSK-C or 5/8" (15.9 mm) FSK	4' (1219 mm)	8' (2438 mm) thru 16' (4876 mm)

Note: 1/2" regular Kal-Kore plaster base available in 54" widths.

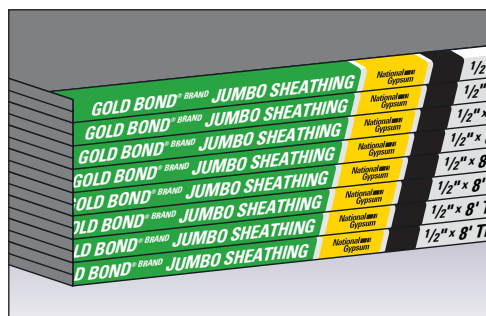

Gold Bond BRAND Gypsum Sheathing is used as an underlayment on exterior walls. Finish materials are applied with fasteners through sheathing into studs or furring strips. Refer to page 28.

Regular 1/2" (12.7 mm)	4' (1219 mm)	8' (2438 mm) thru 10' (3048 mm)
Type X 5/8" (15.9 mm) FSW-3	4' (1219 mm)	8' (2438 mm) thru 10' (3048 mm)

09 29 00

Description

Core Thickness/Type Width/Edge Lengths

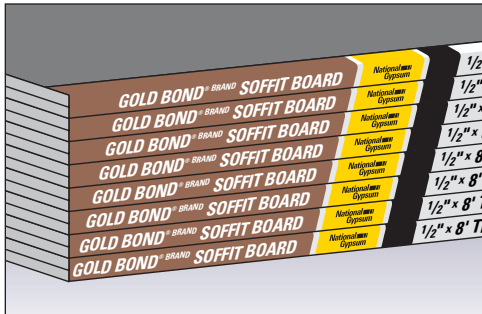

Gold Bond BRAND Exterior Soffit Board is designed to provide, in a fire resistive gypsum ceiling board, the extra resistance to moisture and sagging required to meet protected outdoor conditions. Refer to page 71.

Regular	1/2" (12.7 mm)	4' (1219 mm) Sta-Smooth	8' (2438 mm) thru 12' (3658 mm)
Type X	5/8" (15.9 mm) FSW	4' (1219 mm) Sta-Smooth	8' (2438 mm) thru 12' (3658 mm)

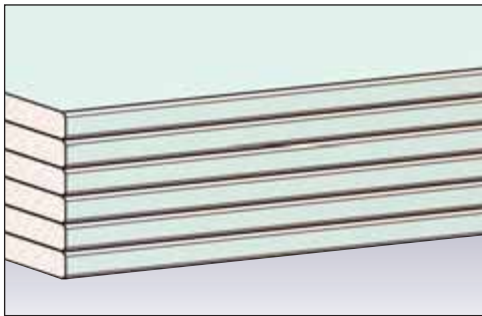

Gold Bond BRAND Fire-Shield Shaftliner is used as a component in shaftwall systems, in area separation walls and in solid gypsum partitions. The product has moisture resistant green paper on both faces. Refer to pages 73, 110, 124 and 140.

Type X	1" (25.4 mm) FSW	2' (610 mm) Beveled Edges	Custom Cut thru 7' (2134 mm) thru 14' (4267 mm)
--------	------------------	---------------------------	---

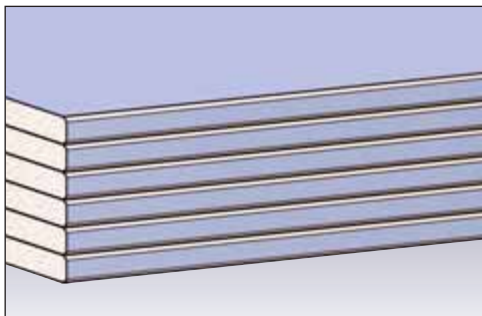

Gold Bond BRAND Fire-Shield Shaftliner XP is used as a component in shaftwall systems, area separation walls and solid laminated gypsum partitions. The product has moisture/mold/mildew resistant purple paper on both faces. Refer to page 74, 110, 124, and 140.

Type X	1" (25.4 mm) FSW	2' (610 mm) Beveled Edges	Custom Cut thru 7' (2134 mm) thru 14' (4267 mm)
--------	------------------	---------------------------	---

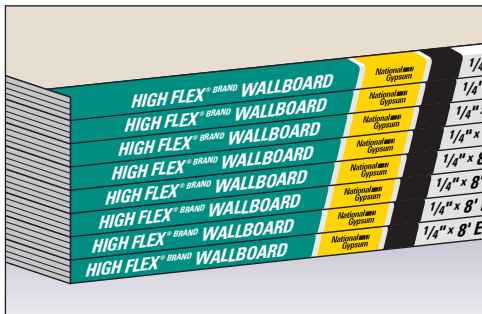

Gold Bond BRAND High Flex Gypsum Board is specifically designed for radius construction such as curved walls, archways and stairways. It can be used for both concave and convex surfaces. 1/4" High Flex is typically applied in double layers. Refer to page 75.

Regular	1/4" (6.3 mm)	4' (1219 mm) Eased	8' (2438 mm) thru 10' (3048 mm)
---------	---------------	--------------------	---------------------------------

Description	Core	Thickness/Type	Width/Edge	Lengths
 <p>Gold Bond BRAND High Strength Ceiling Gypsum Board is designed to resist sagging equal to 5/8" gypsum board. Installed perpendicular to framing, span can be up to 24" o.c. Can be decorated with spray textures and will support insulation. Refer to page 77.</p>	Regular	1/2" (12.7 mm)	4' (1219 mm) Tapered	6' (1828 mm)
				thru
				16' (4876 mm)
				1/2" x 12'
				1/2" x 12'
				1/2" x 12'

 <p>Gold Bond BRAND Hi-Abuse XP Fire-Shield Gypsum Board is designed for use in areas where surface durability and indentation resistance are major concerns. The product is manufactured with a mold and fire resistive Type X gypsum core encased in heavy smooth abrasion resistant, mold/mildew resistant purple paper on the face side and heavy mold/mildew resistant liner paper on the back side. Refer to page 78.</p>	Regular	5/8" (15.9 mm) FSW	4' (1219 mm) Square or Tapered	8' (2438 mm)
				thru
				12' (3657 mm)
				5/8" x 12'
				5/8" x 12'
				5/8" x 12'

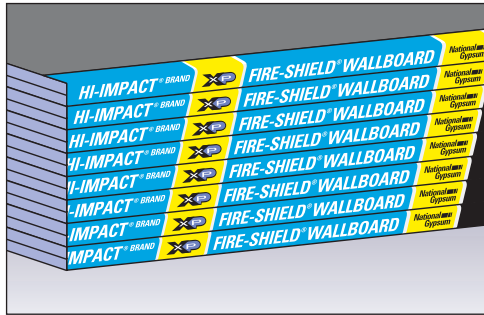
 <p>Gold Bond BRAND Hi-Impact XP Fire-Shield Gypsum Board is designed for use in areas where impact/penetration resistance is a major concern. The product is manufactured with a mold, moisture and fire resistant Type X gypsum core encased in heavy smooth abrasion resistant, moisture, mold/mildew resistant purple paper on the face side and heavy mold/mildew resistant liner paper on the back side. A fiberglass mesh is embedded in the board to provide additional impact/penetration resistance. Refer to page 81.</p>	Type X	5/8" (15.9 mm) FSW-5	4' (1219 mm) Tapered	8' (2438 mm)
				thru
				12' (3657 mm)
				5/8" x 12'
				5/8" x 12'
				5/8" x 12'

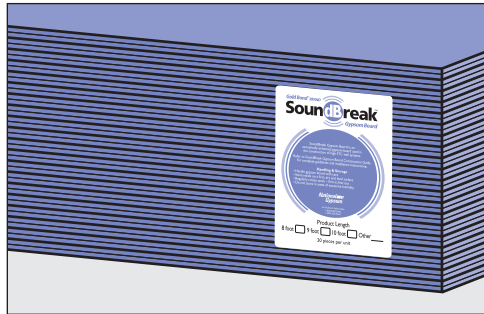
 <p>Gold Bond BRAND Soundbreak Gypsum Board is an acoustically enhanced gypsum board used in the construction of high rated STC wall assemblies. This 5/8" thick gypsum board consists of a layer of viscoelastic damping polymer sandwiched between two pieces of enhanced high density mold resistant gypsum board, providing constrained layer damping. Refer to page 84.</p>	Regular	5/8" (15.9 mm)	4' (1219 mm) Tapered	8' (2438 mm)
				thru
				12' (3658 mm)
				5/8" x 12'
				5/8" x 12'
				5/8" x 12'

09 29 00

Description

Core Thickness/Type Width/Edge Lengths

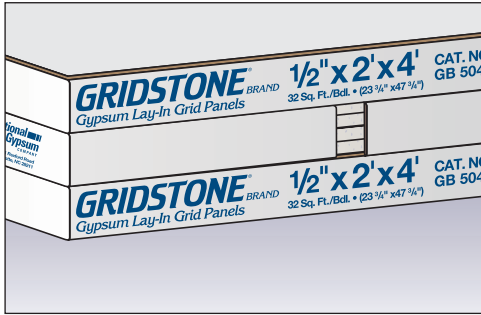

Gridstone BRAND Ceiling Panels have a fire resistant Fire-Shield G, type X core with a 2-mil textured vinyl laminate surface suited for interior or exterior application in exposed grid systems. Refer to page 86.

Type X 1/2" (12.7 mm) FSW-G 2' (610 mm) 2' (610 mm)
2' (610 mm) 4' (1219 mm)
Square

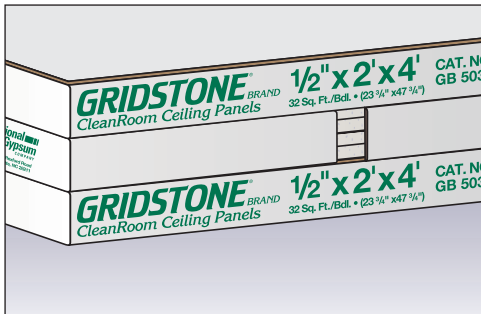

Gridstone BRAND CleanRoom Panels are designed for areas requiring high levels of air cleanliness for airborne particulate. Boards are sealed on face, back and long edges with a 2-mil rigid vinyl film and exposed edges are factory sealed with durable coating providing a completely sealed panel. Refer to page 87.

Type X 1/2" (12.7 mm) FSW-G 2' (610 mm) 2' (610 mm)
2' (610 mm) 4' (1219 mm)
Square

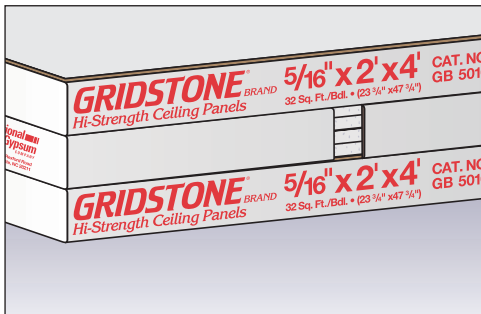

Gridstone BRAND Hi-Strength Ceiling Panels have a non-combustible high strength sag resistant gypsum core with a 2-mil textured vinyl laminate surface suited for interior or exterior application in exposed grid systems. Refer to page 88.

Regular 5/16" (7.9 mm) 2' (610 mm) 2' (610 mm)
2' (610 mm) 4' (1219 mm)
Square

METRIC CAPABILITIES

The Federal Government has mandated that each federal agency make a transition to the use of metric units in all federal procurement, grants and business-related activities. National Gypsum Company, in complying with this order, provides a full line of gypsum board products in "hard" metric dimensions with regard to width and length. Standard board offerings are made in the width of 1200 mm and a length of 3600 mm. Job size lengths are available on a special order basis requiring minimum orders and extended lead times. Contact your local National Gypsum Company representative for further information. Thickness of gypsum board will be "soft" converted to the metric equivalent.

ENVIRONMENTAL CONDITIONS

Maintain a room temperature of not less than 40°F (4°C) during application of gypsum board except when adhesive is used for the attachment of gypsum board. For the bonding of adhesive, joint treatment, texturing, and decoration, the room temperature shall be maintained at least at 50°F (10°C) for 48 hours prior to application and continuously thereafter until completely dry.

Note 1: Precaution—When a temporary heat source is used, the temperature shall not exceed 95°F (35°C) in any given room or area.

Note 2: Precaution—Maintain adequate ventilation in the working area during installation and curing period.

Protect gypsum board products from direct exposure to rain, snow, sunlight, or other excessive weather conditions.

GUIDELINES FOR PREVENTION OF MOLD GROWTH ON GYPSUM BOARD

Gypsum board does not generate or support the growth of mold when it is properly transported, stored, handled, installed, and maintained. However, mold spores are present everywhere and when conditions are favorable, mold can grow on practically any surface. Observing these guidelines will help minimize the potential for mold growth on gypsum board. Gypsum board must be kept dry to prevent the growth of mold.

Transportation and Receiving

Gypsum board must be protected during transit with a weather-tight cover in good condition.

Plastic shipping bags are intended to provide protection during transit only and must be promptly removed upon arrival of the load. Failure to remove the shipping bag can increase the likelihood of developing conditions favorable to the growth of mold.

Storage and Handling

Gypsum board must be stored in an area that protects it from adverse weather conditions, condensation, and other forms of moisture.

Job site conditions that can expose gypsum board to water or moisture must be avoided.

Gypsum board must be delivered to the job site as near to the time it will be used as possible.

Application

Provisions must be made to keep gypsum board dry throughout application.

Gypsum board that has visible mold growth must not be used.

Gypsum board on walls must be applied with a minimum 1/4" (6.35 mm) gap between the gypsum board and the floor.

Gypsum board must not be applied over building materials where conditions exist that are favorable to mold growth.

Maintenance Following Application

Essential elements of sound weather tight building envelope must be properly maintained, such as the roof, sealants, windows, etc.

Immediate and appropriate remediation measures must be taken as soon as water leaks or condensation sources are identified.

Routine cleaning and maintenance operations must be performed so as to prevent saturation of the gypsum board.

Additional Sources of Information

The following Web sites provide information and recommendations for treating mold growth; other sites also provide similar suggestions.

California Indoor Air Quality Program at <http://www.cal-iaq.org/iaqsheet.html>

Federal Emergency Management Agency at <http://www.fema.gov/pdf/hazards/fststpbbr.html>

New York City Department of Health at <http://www.ci.nyc.ny.us/html/doh/html/epi/moldrpt1.html>

U. S. Environmental Protection Agency at <http://www.epa.gov/iedweb00/pubs/moldresources.html>

GA-238, Copyright Gypsum Association

LIMITATIONS

1. Maximum stud spacing for single layer application of 1/2" and 5/8" gypsum board is 24" o.c. If 3/8" gypsum board is used, it must be applied in two layers, with the second layer adhesively applied; 24" o.c. stud spacing may be used.
2. Where long, continuous runs of this wall system are employed, control joints must be provided every 30' or less.
3. Where structural movement may impose direct loads on these systems, isolation details are required.
4. Partitions should not be used where frequently exposed to excessive moisture unless all surfaces are waterproofed.
5. To prevent weakening due to calcining, gypsum board should not be exposed to temperatures over 125°F (52°C) for extended periods of time.
6. Gypsum board joints on single layer, or the face layer on two layer applications, shall not occur within 12" of the corners of door frames unless control joints are installed at the corners.
7. When gypsum board abuts concrete floors, cut board to allow for 1/8" to 1/4" clearance between board and floor to prevent potential wicking.

GOLD BOND® BRAND GRIDMARX®

DESCRIPTION

Gold Bond® BRAND Gypsum Board comes standard with GridMarX™ guide marks, printed on the paper surface. These guide marks align with standard building dimensions and help to quickly identify fastener lines for stud and joist framing. Using GridMarX, accurate cuts can be made without having to draw lines. GridMarX also assist with quick identification of nail/screw pattern.

GridMarX guide marks run the machine direction of the board at five points in 4" increments. Marks run along the edge in both tapers and at 16", 24" and 32" in the field of the board. The marks cover

easily with no bleed-through using standard paint products.

Vertical Application - In a vertical application, GridMarX serve as a **guide mark** to help identify the exact location of framing members behind the gypsum board, eliminating the need for field applied vertical lines.

Horizontal Application - In a horizontal application, GridMarX serve as a **reference mark** to help identify the location of framing members behind the gypsum board. (If framing member is located 2" to the right of the GridMarX at the top edge of the board, it will be located 2" to the right down the face of the board.)



DETAILS

GRIDMARX — VERTICAL WALL APPLICATION

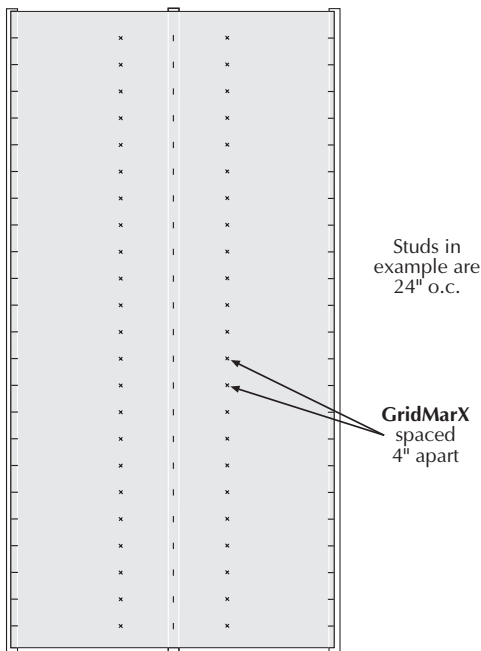

GRIDMARX — HORIZONTAL WALL AND CEILING APPLICATION

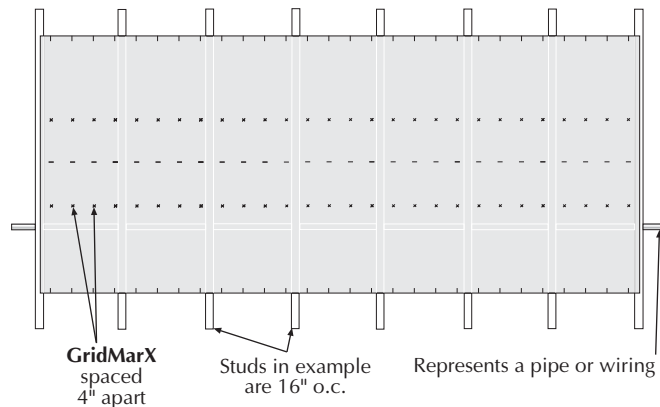

DESCRIPTION

Gypsum Board is the name for a family of board products consisting of a noncombustible core, primarily of gypsum, with a paper surfacing on the face, back and long edges.*

The popularity of gypsum board results from a number of factors. First, it takes virtually any decoration – from paint or textures to vinyl and paper laminates. It also lends itself to creative shaping of interior surfaces, allowing the maximum in design flexibility. Gypsum board is an economical alternative to other products. Because it is lightweight, it is easy to handle for speedy installation. With its natural properties, it is durable yet easy to repair. In addition, gypsum board's fire resistance and sound control capabilities further demonstrate its desirability in building systems.

Ever conscious of the environmental challenges we face in today's world, National Gypsum produces its gypsum board with 100 percent recycled paper on both the face and back.

Gold Bond gypsum board is available with a variety of edge configurations. For easy joint finishing, the tapered edge is preferred to provide a monolithic surface. Where joints will be exposed, square or beveled edges should be considered. National Gypsum also manufactures gypsum board with proprietary edge configurations made to accommodate a variety of wall systems and finishing techniques.

*GA-216

Fire and sound ratings for building systems utilizing gypsum board are dependent on the core type and thickness of the gypsum

TECHNICAL DATA

Fire and sound ratings for building systems utilizing gypsum board are dependent on the core type and thickness of the gypsum board, its application in conjunction with the component parts, and the manner in which it is applied.

Tests for fire resistance and sound transmission, performed by independent laboratories, have resulted in specific ratings for walls/partitions; floor/ceiling assemblies; shaftwalls, stairwells and area separation walls; and columns. For maximum fire resistance and sound control, double layer construction is generally recommended since the additional mass further retards heat and noise penetration.

Gypsum board can be installed to both metal and wood framing using nails, screws or adhesives in combination with nails or screws. In many instances, the application will dictate which fastening method is appropriate.

Control joints may be necessary to prevent cracking in the gypsum board facing of drywall systems, especially in areas where structural elements such as slabs, columns or exterior walls can bear directly on non-load-bearing partitions. To relieve the stresses which occur as a result of movement induced by changes in moisture, temperature or both, control joints are required in both partitions and ceilings.

GYPSUM BOARD INSULATING PROPERTIES

For purposes of calculating "U" values, the "C" factor for 1" gypsum board is 1.2; Resistance "R" for 3/8" board is .32; for 1/2" board .45; for 5/8" board .56 and for 1" board .83.

WEIGHTS

- 1/4" Regular - 1.2 lbs/SF
- 3/8" Regular - 1.2 lbs/SF
- 1/2" Regular - 1.6 lbs/SF

RECOMMENDATIONS

Examine and inspect materials to which gypsum board is to be applied. Remedy all defects prior to installation of drywall. Any defects in the finished installation due to misaligned framing or other cause will be the responsibility of the work performed under that section of the specification and such defects shall be remedied under that section of the specification.

Gypsum board shall be applied first to ceiling at right angles to framing members, then to walls. Boards of maximum practical length shall be used so that an absolute minimum number of end joints occur. Board edges shall be brought into contact with each other but shall not be forced into place.

Gypsum board joints at openings shall be located so that no end joint will align

with edges of opening unless control joints will be installed at these points. End joints shall be staggered, and joints on opposite sides of a partition shall not occur on the same stud.

Gypsum board shall be held in firm contact with the framing member while fasteners are being driven. Fastening shall proceed from center portion of the board toward the edges and ends. Fasteners shall be set with the heads slightly below the surface of the board in a dimple formed by the hammer or power screwdriver. Care shall be taken to avoid breaking the face paper of the gypsum board. Improperly driven nails or screws shall be removed.

See page 63, *Environmental Conditions and Limitations.*

CURVED SURFACES

To apply gypsum board over a curved surface, place a stop at one end of the board and then gently and gradually push on the other end, forcing the center against the framing until the curve is complete. Shorter radii than shown in the table may be obtained by moistening the face and back papers of the board with water, stacking on a flat surface, and allowing the water to soak into the core for at least one hour. When the board is dry it will regain its original hardness.

Gypsum board may be applied to curved surfaces in accordance with the following:

GYPSUM BOARD BENDING RADII

Thickness	Bending Lengthwise	Bending Widthwise
1/4" (6.4 mm)	5'-0" (1524 mm)	15'-0" (4572 mm)
3/8" (9.4 mm)	7'-6" (2286 mm)	25'-0" (7620 mm)
1/2" (12.7 mm)	*10'-0" (3048 mm)	
5/8" (15.9 mm)	15'-0" (4572 mm)	

*Bending two layers of 1/4" (6.4 mm) board successively will permit a bending radius shown for 1/4" (6.4 mm) board.

Note: To achieve tighter bending radii, use Gold Bond 1/4" High Flex Gypsum Board. See page 75 for additional information and 1/4" High Flex minimum bending radii chart.

SURFACE BURNING CHARACTERISTICS

(Fire Hazard Classification) Tested in accordance with ASTM E 84

	Gypsum Board	Gypsum Sheathing	Durasan All Standard Patterns
Flame Spread Index	15	20	25 or less
Smoke Developed	0	0	50 or less

SPECIFICATIONS

THE FOLLOWING PARAGRAPHS ARE FOR INSERTION INTO SECTIONS OF GENERIC SPECIFICATIONS OR GENERIC/PROPRIETARY SPECIFICATIONS COVERING GYPSUM BOARD PRODUCTS. THE NATIONAL GYPSUM PRODUCT NAME FOLLOWS THE GENERIC DESCRIPTION IN PARENTHESES.

PART 2 PRODUCTS 2.01 MATERIALS

A. Regular Gypsum Board: A gypsum core board that is fire resistant and surfaced with paper on front/back and long edges and complies with ASTM C 1396.

1. Thickness: 1/4", 3/8", 1/2" (Gold Bond BRAND Gypsum Board)
2. Width: 4'
3. Length: 6' through 16'.
4. Edges: Square, Tapered, or Beveled Tapered (Sta-Smooth Edge).

PART 3 EXECUTION 3.01 INSTALLATION

A. General: In accordance with the manufacturer's recommendations, National Gypsum Company "Gypsum Construction Guide."

Gold Bond® BRAND Fire-Shield® Gypsum Board

DESCRIPTION

Gold Bond® BRAND Fire-Shield® Gypsum Board was developed to work in combination with other products in an assembly to retard heat transfer through the assembly. Fire-Shield gypsum boards are made with cores formulated to offer greater fire resistance than regular gypsum board. Generically, these fire resistant boards that are used to delay heat transfer to structural members are designated as "type X" products.

The Gypsum core of Fire-Shield Gypsum Board works as a natural "sprinkler system." Gypsum naturally contains about 21 percent water. When the board is heated, the water in the core begins to evaporate and is released as steam, retarding heat transfer. Fire-Shield gypsum board remains noncombustible. However, as shrinkage occurs because of the loss of water volume, cracks occur which permit passage of fire and heat. To lessen this process, Fire-Shield gypsum board is formulated by adding noncombustible fibers to the gypsum to help maintain the integrity of the core as water volume is lost while providing greater resistance to heat transfer.

TECHNICAL DATA

SYSTEM BURNING CHARACTERISTICS

ASTM E84
Flame Spread: 15
Smoke Developed: 0

According to ASTM C 1396, the standard for gypsum board, type X gypsum board must provide at least: a one-hour fire resistance rating for 5/8" board, or a 3/4-hour fire resistance rating for 1/2" board applied in a single layer nailed on each face of load-bearing wood framing members when tested in accordance with the requirements of Methods of Fire Test of Building Constructions and Materials (ASTM designation E 119).

For additional fire protection, Gold Bond Fire-Shield C products are formulated with a mineral core additive which expands when subjected to heat which aids in holding the gypsum board together.

Fire-Shield gypsum boards also can be used as column protection, delaying the rapid transfer of heat to reduce the likelihood that structural members will lose strength and fail to carry the intended load.

FIRE RESISTANCE RATINGS

Fire resistance ratings represent the results of tests on assemblies made up of specific materials in a specific configuration. When selecting construction designs to meet certain fire resistance requirements, caution must be used to insure that each component of the assembly is the one specified in the test. Further, precaution should be taken that assembly procedures are in accordance with those of the tested assembly. (For copies of specific tests, call 1-800-NATIONAL.)

WEIGHTS

1/2" Type C - 1.9 lbs/SF
5/8" Type X - 2.2 lbs/SF
5/8" Type C - 2.2 lbs/SF

For fire safety information, go to www.nationalgypsum.com.

RECOMMENDATIONS

Examine and inspect materials to which gypsum board is to be applied. Remedy all defects prior to installation of drywall. Any defects in the finished installation due to misaligned framing or other cause will be the responsibility of the work performed under that section of the specification and such defects shall be remedied under that section of the specification.

Gypsum board shall be applied first to ceiling at right angles to framing members, then to walls. Boards of maximum practical length shall be used so that an absolute minimum number of end joints occur. Board edges shall be brought into contact with each other but shall not be forced into place.

SPECIFICATIONS

THE FOLLOWING PARAGRAPHS ARE FOR INSERTION INTO SECTIONS OF GENERIC SPECIFICATIONS OR GENERIC/PROPRIETARY SPECIFICATIONS COVERING GYPSUM BOARD PRODUCTS. THE NATIONAL GYPSUM PRODUCT NAME FOLLOWS THE GENERIC DESCRIPTION IN PARENTHESES.

PART 2 PRODUCTS

2.01 MATERIALS

- A. Fire-Resistant Gypsum Board: A gypsum core gypsum board with additives to enhance fire resistance of the core and surfaced with paper on front, back, and long edges and complying with ASTM C 1396, type X.
1. Thickness: 1/2" (Gold Bond BRAND Fire-Shield C Gypsum Board), 5/8" (Gold Bond BRAND Fire-Shield Gypsum Board), or 5/8" (Gold Bond BRAND Fire-Shield C Gypsum Board)
 2. Width: 4'
 3. Length: 6' through 16'
(1/2" Fire-Shield C Gypsum Board,
5/8" Fire-Shield Gypsum Board)
Length: 8' through 14'
(5/8" Fire-Shield C Gypsum Board)
 4. Edges: Square, Tapered, or Beveled Tapered (Sta-Smooth Edge)

PART 3 EXECUTION

3.01 INSTALLATION

- A. General: In accordance with the manufacturer's recommendations, National Gypsum Company "Gypsum Construction Guide."

Gypsum board joints at openings shall be located so that no end joint will align with edges of opening unless control joints will be installed at these points. End joints shall be staggered, and joints on opposite sides of a partition shall not occur on the same stud.

Gypsum board shall be held in firm contact with the framing member while fasteners are being driven. Fastening shall proceed from center portion of the board toward the edges and ends. Fasteners shall be set with the heads slightly below the surface of the gypsum board in a dimple formed by the hammer or power screwdriver. Care shall be taken to avoid breaking the face paper of the gypsum board. Improperly driven nails or screws shall be removed.

See page 63, *Environmental Conditions and Limitations*.

DESCRIPTION

Sta-Smooth is a drywall system offering maximum joint strength and easy application. It can be used in any gypsum drywall system where conventional types of gypsum board are recommended. This system features Sta-Smooth Brand gypsum board with a unique edge. The two edge configurations relieve joint deformity problems caused by twisted framing, damaged gypsum board edges, poor alignment and extremes in humidity and temperature. Regular Sta-Smooth Boards are available in 1/2" thicknesses, 4' wide and in customary gypsum board lengths. The Sta-Smooth System is also composed of ProForm BRAND Sta-Smooth Joint Compounds, a hardening-type taping compound and regular Gold Bond tape and finishing compounds.

ADVANTAGES

Improved Durability – The Sta-Smooth System produces a smooth, flat, durable surface that relieves beading, ridging and other joint deformity problems.

Greater Speed – All flat joints in the Sta-Smooth System are filled and taped with any Sta-Smooth Compounds all in one easy operation, the same as conventional gypsum board application methods. Sta-Smooth Compounds or regular compounds can be used to tape inside corners, cornerbeads, and spot fasteners. Regular ProForm finishing compounds or Sta-Smooth compounds are used for the remaining finishing coats.

Easier Handling – The improved edge designs on Sta-Smooth Boards makes handling easier with greater comfort to the hands.

No Special Equipment – All conventional fasteners, adhesives, and gypsum board application tools (T-squares, knives, etc.) can be used to apply Sta-Smooth Boards. Nothing new to buy.

Alignment – Sta-Smooth board with its unique edge (either configuration) allows for easy alignment of the boards in the same way as conventional tapered edge board. The taper is scientifically designed to reduce crowned joints.

Stronger Bond – The bonding area of the Sta-Smooth Joint Compounds are increased with the "V" edge boards. The Sta-Smooth Joint Compound used to bond the joint tape and fill the joints is a hardening-type, high density material with low shrinkage characteristics.

Strength – The Sta-Smooth joint shape and the joint compound are developed to provide greater mass and integral bond for increased strength. Sta-Smooth Joint Compounds add considerable strength which is unaffected by the amount of moisture normally introduced into a structure that could cause ridging or beading with conventional joint compounds.

Cost – If application techniques are followed as recommended, the Sta-Smooth System should cost no more and can cost considerably less than conventional gypsum board drywall joint finishing. The initial savings are immediately demonstrated with reduced travel time that results from this perfected 2-trip, 3-step joint finishing system. Future cost savings will be realized with reduced callbacks.

Better Butt Joints – Recommended with the Sta-Smooth System is an improved technique for providing a smoother, flatter, stronger butt joint. Although this technique could be used in conventional drywall work and produce better butt joints, it is further improved by the use of the high strength Sta-Smooth Compound.

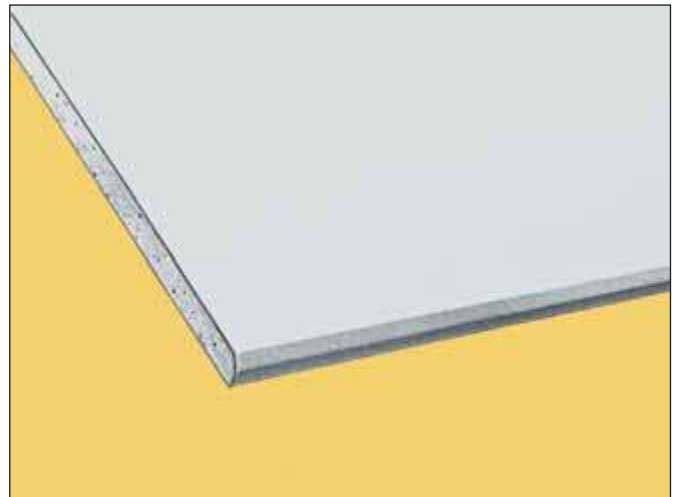

Easier Scheduling – Taping with Sta-Smooth Compounds and applying the first finishing coat, even before the Sta-Smooth used for taping has dried, allows easier job scheduling for the drywall contractor and finisher. This is particularly advantageous under slow drying conditions.

TECHNICAL DATA

SURFACE BURNING CHARACTERISTICS

ASTM E-84
Flame Spread: 15
Smoke Developed: 0

WEIGHTS

1/2" Regular - 1.6 lbs/SF
5/8" Type X - 2.2 lbs/SF
5/8" Type C - 2.2 lbs/SF

DETAILS

THE SECRET IS IN THE SHAPE OF THE JOINT AND THE STRENGTH OF THE COMPOUND



Standard tapered-beveled edge configuration.



Round edge configuration.

The Sta-Smooth System produces a superior joint because the Sta-Smooth Compounds are a hardening-type compound that is not affected by humidity once it has hardened and dried. It also maintains its hard core even with moisture added by the use of the regular joint compounds for the finishing work. Sta-Smooth Compound firmly bonds the tape to the board and the board "V" edges to each other making a strong, rigidized joint.

Consult your local National Gypsum sales representative for edge configuration available in your market.

09 29 00

RECOMMENDATIONS

Note: Sta-Smooth Gypsum Board may be used with any of the Gypsum Drywall Systems described in this Gypsum Construction Guide.

All specifications for the application of gypsum board as described in this literature may also serve for the application of Sta-Smooth Boards. Any deviation from these specifications is as indicated below.

- A. BOARD APPLICATION:** Position each Sta-Smooth Board so that the long edges are in light contact with the edges of the previous boards. All boards positioned to form butt joints should have a gap approximately 1/16" between the board ends. This spacing can be assured by driving 2 extra fasteners at the end of the board to act as temporary spacers before abutting the next board. When the boards are fastened in place, drive the temporary spacers flush with surface. When gypsum board is applied horizontally, recess all butt joints on the job by shimming the face of the studs (or joists), on both sides of the studs (or joists), on which the joint will fall. The shim can be pressed paper, thickness of building felt or other suitable materials not to exceed 1/16" thickness and as wide as the stud or joist. It should be 6" longer than the butt joint and applied to the face of the stud or joist with staples or nails allowing the shim to extend under the edge of the abutting boards of gypsum board to assure that the board facings remain on the same plane.
- B. CORNERS AND OPENINGS:** All exterior corners and all openings that require joint treatment should receive protective reinforcement of ProForm Multi-Flex Tape Bead or Steel Cornerbead or Steel Casing Bead as required.
- C. TREATMENT OF JOINTS*:** All flat Sta-Smooth gypsum board joints are taped with ProForm BRAND Sta-Smooth Compounds, making sure that a sufficient amount of compound is forced into the "V" joint and spread under the tape to form a solid foundation for the finishing coats.**
1. As soon as the Sta-Smooth Joint Compound used for taping has hardened, the first finishing coat can be applied even when the Sta-Smooth Compound is still wet.
 2. When the first finishing coat is completely dry the second finishing coat can be applied. Any of the ProForm Joint Compounds may be used for the finishing coats.
 3. Sta-Smooth Joint Compounds are recommended for the first coat on nail or screw heads. Regular finishing compounds may be used for subsequent spotting of the fasteners. Sta-Smooth Compounds are also recommended for the first coat on cornerbead and followed by one or more finishing coats as required of regular ProForm Joint or Topping Compounds.
 4. The inside corners may be treated with any of the ProForm Joint Treatment Compounds recommended for taping. If a two-trip joint treatment operation is planned, the inside corners are taped with Sta-Smooth Joint Compounds. This will permit finishing one side of the inside corners the first day. Cornerbead is treated with Sta-Smooth Compounds if a two-trip operation is employed.

*Alternate Method: When mechanical tools are to be used for taping joints, Sta-Smooth Compounds are used to fill the "V" joint only. Other ProForm Joint Compounds are then used to bed the tape and finish the joints. (See page 69.)

**Sta-Smooth, Sta-Smooth HS and Sta-Smooth Lite Joint Compounds are recommended for pre-fill or tape/bed coat operations in the Sta-Smooth system.

See page 63, *Environmental Conditions and Limitations.*

SPECIFICATIONS

THE FOLLOWING PARAGRAPHS ARE FOR INSERTION INTO SECTIONS OF GENERIC SPECIFICATIONS OR GENERIC/PROPRIETARY SPECIFICATIONS COVERING GYPSUM BOARD PRODUCTS. THE NATIONAL GYPSUM PRODUCT NAME FOLLOWS THE GENERIC DESCRIPTION IN PARENTHESES.

PART 2 PRODUCTS

2.01 MATERIALS

- A. Gypsum Board: A gypsum core wall board surfaced with paper on front, back, and long edges and complying with ASTM C 1396 (Gold Bond BRAND Gypsum Board).
1. Thickness: 1/2"
 2. Width: 4'
 3. Length: 6' through 16'
 4. Edge: Beveled Tapered (Sta-Smooth Edge)
- B. Fire-Resistant Gypsum Board: A gypsum core wall board with additives to enhance fire resistance of the core and surfaced with paper on front, back, and long edges and complying with ASTM C 1396, type X.
1. Thickness: 1/2" (Gold Bond BRAND Fire-Shield C Gypsum Board), 5/8" (Gold Bond BRAND Fire-Shield Gypsum Board), or 5/8" (Gold Bond BRAND Fire-Shield C Gypsum Board)
 2. Width: 4'
 3. Length: 6' through 16'
(1/2" Fire-Shield C Gypsum Board,
5/8" Fire-Shield C Gypsum Board)
 - Length: 8' through 14'
(5/8" Fire-Shield C Gypsum Board)
 4. Edge: Beveled Tapered (Sta-Smooth Edge)
 5. Edge: Rounded (Sta-Smooth Edge)
- C. Exterior Gypsum Soffit Board: A gypsum core soffit board with additives to enhance the sag resistance of the core; surfaced with water repellent paper on front, back, and long edges; and complying with ASTM C 1396 (Gold Bond BRAND Exterior Soffit Board).
1. Thickness: 1/2"
 2. Width: 4'
 3. Length: 8' through 12'
 4. Edge: Beveled Tapered (Sta-Smooth Edge)
- D. Fire-Resistant Exterior Gypsum Soffit Board: A gypsum core soffit board with additives to enhance the fire-resistance and the sag resistance of the core; surfaced with water repellent paper on front, back, and long edges; and complying with ASTM C 1396, type X (Gold Bond BRAND Fire-Shield Exterior Soffit Board).
1. Thickness: 5/8"
 2. Width: 4'
 3. Length: 8' through 12'
 4. Edge: Beveled Tapered (Sta-Smooth Edge)

PART 3 EXECUTION

3.01 INSTALLATION

- A. General: In accordance with the manufacturer's recommendations, National Gypsum Company "*Gypsum Construction Guide.*"

INSTALLATION



Application And Fastening



1. Fill Joint And Bed Tape Simultaneously



2. First Finishing Coat



3. Second Finishing Coat

APPLICATION AND FASTENING

Sta-Smooth Boards may be nailed, screwed or adhesively applied to wood studs or furring, or screwed or adhesively applied to steel studs or furring, using conventional type and length of fastener. All fasteners shall be applied a minimum of 3/8" (maximum 1/2") from the edges and ends of each board. Then treat the joints in three simple steps.

CONVENTIONAL TAPING AND FINISHING

1. Fill Joint And Bed Tape Simultaneously

All flat gypsum board joints are to be filled and taped in one operation with ProForm BRAND Sta-Smooth Compounds, using ProForm Paper Tape in the conventional manner. When Sta-Smooth HS tape is used, the self-adhering fiberglass mesh tape is firmly pressed to the gypsum board, spanning the joints. Sta-Smooth Compounds can then immediately be applied to the joints. The compound must be forced through the tape to fill the channel formed by the "V" edges of the Sta-Smooth gypsum board. All inside corners may be taped using regular ProForm compounds. Sta-Smooth Compounds are used for the first coat on nail or screw heads and will decrease problems with fastener imperfections. Inside angles, first and second finishing coats may be done using regular ProForm joint compounds.

2. First Finishing Coat

As soon as the Sta-Smooth Compound used for taping has hardened, the first finishing coat may be applied on the flat joints even before it is dry. Any ProForm joint compound may be used for this operation. A second coat may be applied at this time to nail or screw heads, one coat on cornerbead if Sta-Smooth Compound was used for the first coat.

3. Second Finishing Coat

As soon as the compounds used for the previous steps have thoroughly dried, a second finishing coat is applied to all flat joints using ProForm Joint Compound or Topping Compound. A third coat is applied over nail or screw heads and on cornerbead as required. The unfinished side of the inside corners is also finished at this time.

STA-SMOOTH ROUND EDGE REQUIRES PRE-FILLING PRIOR TO BED & TAPING

Application Instructions For Round Edge Sta-Smooth Gypsum Board

- 1) Mix Sta-Smooth Joint Compound, Sta-Smooth Lite Joint Compound or Sta-Smooth HS Joint Compound as per bag instructions. Care should be taken to mix no more compound than can be applied in the designated set time.
- 2) Pre-fill all joints formed by the abutting round edge Sta-Smooth Gypsum Boards with Sta-Smooth Compound, Sta-Smooth Lite Joint Compound or Sta-Smooth HS Joint Compounds using a conventional joint finishing knife. Fill joints, level and wipe off excess compound to the lowest level of the taper, allowing enough room for embedding the tape. Allow prefill material to harden prior to application of tape and bed coat.
- 3) Finish joints in the normal manner.

TAPING AND FINISHING WITH MECHANICAL TOOLS

Taping – Taping tools such as the "banjo" and "hopper" types are recommended for taping the flat joints with Sta-Smooth Compounds and the inside corners with ProForm regular joint compounds or with Sta-Smooth Compounds. **Automatic taping tools are not recommended for use with hardening-type compounds.** Mechanical tools can be used for taping the inside corners when a ProForm regular joint compound is used. When automatic taping tools are used for taping the flat joints, the "V" formed by the edges of Sta-Smooth board on the flat joints and all spaces between the gypsum board edges on butt joints are pre-filled with Sta-Smooth Compounds and allowed to harden (30 minutes longer than the set time designated on the bag) prior to taping with a regular ProForm joint compound.

Finishing – Mechanical type finishing tools can be used in the normal manner for the finishing operations of the Sta-Smooth System since conventional ProForm finishing compounds are used.

MIXING INSTRUCTIONS

ProForm BRAND Sta-Smooth Compounds are available in 20, 45, 90 and 210 minute set times. MIX NO MORE COMPOUND THAN CAN BE APPLIED IN THE DESIGNATED SET TIME. Contact your National Gypsum Company Representative for availability. A plastic container is recommended because of its ease in cleaning between batches. Do not use a wood or aluminum bucket. Add the compound gradually to clean water while stirring. Note: Use only fresh, clean water suitable for human consumption. Mix at the ratio of 13-14 pints of water to the 25 lb. bag. Mix the compound free of lumps with a mechanical mixer or by hand. Mechanical mixing is recommended. Allow to stand 5 minutes as a "wetting" period and remix to further improve the working qualities. If a slightly thinner compound is desired, add an additional pint of water, or less, after the compound is thoroughly mixed.

Gold Bond® BRAND XP® Gypsum Board

DESCRIPTION

Gold Bond® BRAND XP® Gypsum Board panels consist of a fire-resistant, mold and moisture-resistant gypsum core encased in heavy moisture/mold/mildew resistant, 100% recycled purple paper on the face and backsides. XP Gypsum Board was designed to provide extra protection against mold and mildew compared to standard gypsum board products. The face paper is folded around the long edges to reinforce and protect the core, and the ends are square-cut and finished smooth. Long edges of panels are tapered. Tapered edges allow joints to be treated in the normal manner. For optimum mold and mildew resistance, National Gypsum recommends ProForm BRAND XP Ready Mix or ProForm BRAND Sta-Smooth/Sta-Smooth Lite setting compounds.

Gold Bond BRAND XP Fire-Shield® Gypsum Board features a type X core to provide additional fire resistance ratings when used in tested systems.

Gold Bond BRAND XP Fire-Shield C Gypsum Board Panels have a specially formulated type X core to achieve superior performance when used in specific fire-rated assemblies where the weight and number of gypsum board layers are a concern.

TECHNICAL DATA

SURFACE BURNING CHARACTERISTICS

ASTM E 84
Flame spread: 15
Smoke developed: 0

FIRE RESISTANCE RATINGS

Fire resistance ratings represent the results of tests on assemblies made up of specific materials in a specific configuration. When selecting construction designs to meet certain fire resistance requirements, caution must be used to insure that each component of the assembly is the one specified in the test. Further, precaution should be taken that assembly procedures are in accordance with those of the tested assembly. (For copies of specific tests,

call 1-800-NATIONAL. For fire safety information, see www.nationalgypsum.com.)

MOLD AND MILDEW RESISTANCE

XP Gypsum Board was designed to provide extra protection against mold and mildew compared to standard gypsum board products. When tested by an independent lab per ASTM D3273 ("Standard Test Method for Resistance to Growth of Mold on the Surface of Interior Coatings in an Environmental Chamber"), XP Gypsum Board achieved a score of 10, the best possible score for this test.

The use of XP Gypsum Board in actual installations may not produce the same results as were achieved in controlled, laboratory conditions. No material can be considered "mold-proof," nor is it certain that any material will resist mold or mildew indefinitely. When used in conjunction with good design, handling and construction practices, XP Gypsum Board can provide increased mold resistance versus standard gypsum board products. As with any building material, exposure during handling, storage, and installation, and after installation is complete, is the best way to avoid the formation of mold or mildew.

WEIGHTS

1/2" Regular - 1.75 lbs/SF
1/2" Type C - 1.95 lbs/SF
5/8" Type X - 2.4 lbs/SF

RECOMMENDATIONS

Exposure to excessive or continuous moisture and extreme temperatures should be avoided. XP Gypsum Board is not recommended where it will be exposed to temperatures exceeding 125°F (52°C) for extended periods of time.

MAXIMUM FRAMING SPACING - For Single Layer XP Gypsum Board			
	Gypsum Board Thickness	Gypsum Board Orientation to Framing	Maximum Framing Spacing
Ceilings:	1/2" (12.7mm)	Parallel	16" (406mm) o.c.
	1/2" (12.7mm)	Perpendicular	24" (610mm) o.c.
	5/8" (15.9mm)	Parallel	16" (406mm) o.c.
Walls:	5/8" (15.9mm)	Perpendicular	24" (610mm) o.c.
	1/2" (12.7mm)	Perpendicular or Parallel	24" (610mm) o.c.
	5/8" (15.9mm)	Perpendicular or Parallel	24" (610mm) o.c.

NOTE: On ceilings to receive hand or spray applied, water based texture material, XP Gypsum Board products shall be applied perpendicular to framing.

XP Gypsum Board can be used as a tile backer board in dry areas or areas with limited water exposure such as directly behind tile in tub and shower areas.

XP Gypsum Board can be installed on the interior south face of exterior walls.

XP Gypsum Board should not be used as a backer board directly behind tile in tub and shower areas.

XP Gypsum Board should not be used in areas subject to constant and/or excessive moisture and high humidity such as gang showers, saunas, steam rooms and swimming pool enclosures. PermaBase BRAND cement board is recommended for these areas.

XP Gypsum Board must be stored off the ground and under cover. Sufficient risers must be used to ensure support for the entire length of the gypsum board to prevent sagging.

XP Gypsum Board must be kept dry to minimize the potential for mold growth. Adequate care should be taken while transporting, storing, applying and maintaining gypsum board. For additional information, refer to the Gypsum Association publication, "Guidelines for the Prevention of Mold Growth on Gypsum Board" (GA-238-03), which is available at www.gypsum.org under the "Download Free Gypsum Association Publications" section.

DECORATION

For best painting results, all surfaces, including joint compound, should be clean, dust-free and not glossy. To improve fastener and joint concealment, a coat of a quality drywall primer is recommended to equalize the porosities between the paper and joint compound.

The selection of a paint to give the specified or desired finished characteristics is the responsibility of the architect or contractor.

XP Gypsum Board that is to have a wallcovering applied to it should be prepared and primed as described for painting.

SPECIFICATIONS

PART 2 PRODUCTS

THE FOLLOWING PARAGRAPHS ARE FOR INSERTION INTO SECTIONS OF GENERIC SPECIFICATIONS OR GENERIC/PROPRIETARY SPECIFICATIONS COVERING GYPSUM BOARD PRODUCTS. THE NATIONAL GYPSUM PRODUCT NAME FOLLOWS THE GENERIC DESCRIPTION IN PARENTHESES.

2.01 MATERIALS

A. Mold-Resistant Gypsum Board: A gypsum core wall panel with additives to enhance the water resistance of the core; surfaced with moisture/mold/mildew resistant paper on front, back and long edges and complying with ASTM C 1396 (Gold Bond BRAND XP Gypsum Board).

1. Thickness: 1/2"
2. Width: 4'
3. Length: 8', 10' or 12'
4. Edges: Square or Tapered
5. Mold and Mildew Resistance: Panel score of 10 when tested in accordance with ASTM D 3273

B. Fire-Resistant Mold and Mildew-Resistant Gypsum Board: A gypsum core wall panel with additives to enhance the fire resistance and water resistance of the core; surfaced with moisture/mold/mildew resistant paper on front, back and long edges and complying with ASTM C 1396, type X.

1. Thickness: 1/2" (Gold Bond BRAND XP Fire-Shield C Gypsum Board), 5/8" (Gold Bond BRAND XP Fire-Shield Gypsum Board), 5/8" (Gold Bond Brand XP Fire-Shield C Gypsum Board.)
2. Width: 4'
3. Length: 8', 10', or 12'
4. Edges: Square or Tapered
5. Mold and Mildew Resistance: Panel score of 10 when tested in accordance with ASTM D 3273

PART 3 EXECUTION

3.01 INSTALLATION

A. General: In accordance with the manufacturer's recommendations, National Gypsum Company "Gypsum Construction Guide."

DESCRIPTION

Gold Bond® BRAND Exterior Soffit Board is designed to provide, in a fire-resistive gypsum board, the extra resistance to moisture and sagging required to meet outdoor conditions. The specially treated gypsum core is covered on both sides with water-repellent paper formed to the Sta-Smooth edge. Boards are 1/2" (regular) and 5/8" (Fire-Shield) x 4' x 8' through 12' lengths.

Typical uses for sheltered exterior ceiling and soffit areas are covered parking areas, walkways and marquees in commercial construction and, in residential construction, carports, breezeways and open porches.



TECHNICAL DATA

1. WEIGHTS

- 1/2" Regular - 1.8 lbs/SF
- 5/8" Type X - 2.2 lbs/SF

2. GENERAL

Use longest practical board lengths to minimize the number of butt joints. Position end joints at supports, allowing 1/16" to 1/8" between butted ends. When board is applied with long edges parallel to framing, framing spacing is 16" o.c. max. When board is applied with long edges perpendicular to framing, framing spacing may be up to 24" o.c. max. Drive fasteners to provide uniform dimples not over 1/32" deep.

3. WOOD FRAMING AND FURRING

Apply Soffit Board with the long edges at right angles to framing. Use Type "W" 1 1/4" Drywall Screws spaced 12" o.c. max. Electric screw gun should be equipped with adjustable depth control and a #2 Phillips bit. 1 1/2" galvanized box nails or 1 1/2" aluminum nails spaced 7" o.c. max., may be used if desired.

Wood furring 1" x 4" nom. may be used for screw application of board where support member spacing does not exceed 24" o.c. Furring 2" x 2" nom. must be used for nail application of board or when support member spacing exceeds 24" o.c. but is not greater than 48" o.c.

4. METAL FRAMING AND FURRING

A suspended framework for support of the ceiling board is composed of 1 1/2" cold-rolled steel channels for main runners and either the Furring Channel or the Steel Stud for cross-furring.

Space main runners as follows: 4' o.c. max. if Furring Channels are to be used, 6' o.c. max. for 2 1/2" Steel Studs, and 8' o.c. max for 3 5/8" Steel Studs. Main runners are suspended with 8 gauge (min.) galvanized wire spaced 4' o.c. max.

Secure Furring Channels to main runners with 1 1/2" Furring Channel Clips, alternating sides at each intersection, or saddle tie with double strands of 16 gauge galvanized tie wire.

Secure Steel Stud furring to main runners with double strand 16 gauge tie wire 16" o.c. max. For added rigidity, nest an 8" length of track at each tie wire location.

Main runners and furring must have a minimum clearance between their ends and any abutting structural element. A main runner must be located within 6" of parallel walls. The ends of these runners must be supported by hangers not more than 6" from the ends. The closest edge of the furring member must be no more than 2" from the parallel wall. At any openings for vents, light fixtures, etc., that interrupt runners or furring, reinforcement must be provided to maintain

support equal to that of the interrupted members.

Apply Soffit Board with 1" Type "S" Screws, 12" o.c. max.

5. CONTROL JOINTS

To compensate for the effect of structural movement on large ceiling areas, control joints in the Ceiling/Soffit Board are recommended. These should be E-Z Strip Expansion Joints.

Install E-Z Strip with 1/2" min. staples 6" o.c. Use additional staples if necessary for snug contact with board. Install joints no more than 30' apart and, if possible, to coincide with expansion joints in the roof above. Control joints may be installed to intersect light fixture or other openings where stresses are usually concentrated. Wings of "L", "U", and "I" shaped areas should always be separated.

6. INTERSECTION WITH OTHER BUILDING ELEMENTS

Allow a minimum 1/4" space between ceiling board and any intersecting structure. Do not caulk this space. Install suitable trim moulding to conceal the gap or use J Casing Bead and flexible sealant.

7. BOARD EDGE PROTECTION

Install fascia so that its drip line is at least 1/4" below the Ceiling Soffit Board molding.

8. VENTILATION

Provide at least 1 sq. ft. of venting to exterior for each 150 sq. ft. of Ceiling/Soffit Board. Vent each enclosed bay. If the space above the ceiling board is not open to areas above or below habitable rooms, provide ventilating area of not less than 1/300 of the ceiling area. Otherwise, vent in accordance with HUD Minimum Property Standard No. 4900.1 or in accordance with local codes.

9. JOINT TREATMENT

ProForm BRAND Sta-Smooth Joint Compound is required for filling, taping and finishing. Since Sta-Smooth is a setting material, cut any high points while still wet and wet sand as necessary.

10. PAINTING

The surface of the Soffit Board should be painted with two coats of exterior paint as soon as joint compound is dry, about one week after joints are completed.

09 29 00

DETAILS

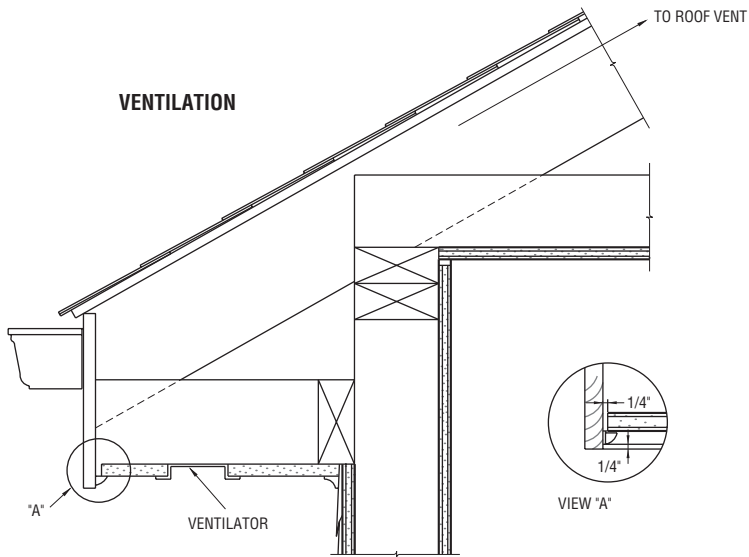

EXTERIOR SOFFIT BOARD VENTILATION

09250A
Scale: 1 1/2" = 1'-0"

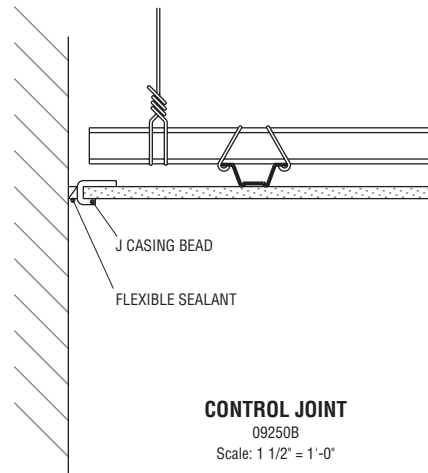

CONTROL JOINT

09250B
Scale: 1 1/2" = 1'-0"

INSTALLATION

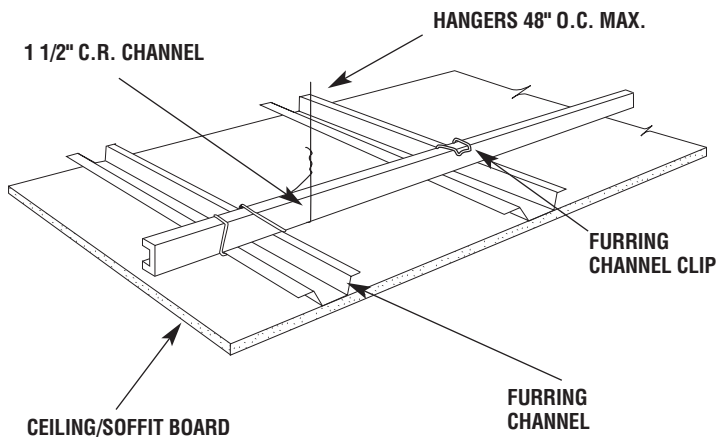

RECOMMENDATIONS

Installation of Gold Bond Exterior Soffit Board should be in accordance with page 70 of the National Gypsum Company "Gypsum Construction Guide."

A qualified structural engineer should evaluate design, including uplift bracing.

See page 63, *Environmental Conditions and Limitations*.

SPECIFICATIONS

THE FOLLOWING PARAGRAPHS ARE FOR INSERTION INTO SECTIONS OF GENERIC SPECIFICATIONS OR GENERIC/PROPRIETARY SPECIFICATIONS COVERING GYPSUM BOARD PRODUCTS. THE NATIONAL GYPSUM PRODUCT NAME FOLLOWS THE GENERIC DESCRIPTION IN PARENTHESES.

PART 2 PRODUCTS

2.01 MATERIALS

- A. Exterior Gypsum Soffit Board: A gypsum core soffit board with additives to enhance the sag resistance of the core; surfaced with water repellent paper on front, back, and long edges; and complying with ASTM C 1396 (Gold Bond BRAND Exterior Soffit Board).

1. Thickness: 1/2"
2. Width: 4'
3. Length: 8' through 12'
4. Edges: Beveled Tapered (Sta-Smooth Edge)

- B. Fire-Resistant Exterior Gypsum Soffit Board: A gypsum core soffit board with additives to enhance the fire resistance of the core; surfaced with water repellent paper on front, back, and long edges; and complying with ASTM C 1396, type X (Gold Bond BRAND Fire-Shield Exterior Soffit Board).

1. Thickness: 5/8"
2. Width: 4'
3. Length: 8' through 12'
4. Edges: Beveled Tapered (Sta-Smooth Edge)

PART 3 EXECUTION

3.01 INSTALLATION

- A. General: In accordance with the manufacturer's recommendations, National Gypsum Company "Gypsum Construction Guide."

DESCRIPTION

Gold Bond® BRAND 1" Fire-Shield Shaftliner panels consist of a fire-resistant type X gypsum core encased in a heavy moisture-resistant green, 100% recycled paper on the face and back sides. The face paper is folded around the long edges to reinforce and protect the core, and the ends are square-cut and finished smooth. Long edges of panels are beveled for ease of installation.

1" Shaftliner panels are designed to be used to construct lightweight fire barriers for cavity shafts and area separation walls in multifamily housing. The panels are key components in the Cavity Shaftwall Systems and the I-Stud and H-Stud Area Separation Wall Systems.

TECHNICAL DATA

SURFACE BURNING CHARACTERISTICS

ASTM E84
 Flame Spread: 15
 Smoke Developed: 0

WEIGHTS

1" Shaftliner - 3.75 lbs/SF

FIRE RESISTANCE RATINGS

Fire resistance ratings represent the results of tests on assemblies made up of materials authorized by National Gypsum in specific configurations. When selecting construction designs to meet certain fire requirements, caution must be used to ensure that each component of the assembly is the one specified in the test.

Further, precaution should be taken that assembly procedures are in accordance with those of the tested assembly. (For copies of specific tests, call 1-800-NATIONAL.)

RECOMMENDATIONS

Installation of 1" Fire-Shield Shaftliner should be consistent with methods described in specific application details for Cavity Shaftwall Systems or H-Stud Area Separation Wall Systems or other fire-rated designs shown in National Gypsum Company "Gypsum Construction Guide."

Exposure to excessive or continuous moisture or standing water and extreme temperatures should be avoided.

To prevent weakening due to calcining, 1" Fire-Shield Shaftliner panels, like any gypsum board, should not be exposed to temperatures over 125°F (52°C) for extended periods of time.

Not to be used in an unlined air supply duct.

Always store Shaftliner Gypsum Panels flat on a level surface and support with properly placed risers. Care should be taken to avoid impact, unwarranted flexing and subsequent damage to board edges, ends and corners.

SPECIFICATIONS

THE FOLLOWING PARAGRAPHS ARE FOR INSERTION INTO SECTIONS OF GENERIC SPECIFICATIONS OR GENERIC/PROPRIETARY SPECIFICATIONS COVERING GYPSUM BOARD PRODUCTS. THE NATIONAL GYPSUM PRODUCT NAME FOLLOWS THE GENERIC DESCRIPTION IN PARENTHESES.

PART 2 PRODUCTS

2.01 MATERIALS

- A. Fire-Resistant Gypsum Shaftliner Board: A gypsum core shaftwall board with additives to enhance fire resistance of the core and surfaced with water resistant paper on front, back and long edges; and complying with ASTM C 1396, type X (Gold Bond BRAND Fire-Shield Shaftliner).
 1. Thickness: 1"
 2. Width: 2'
 3. Length: 7' through 14'
 4. Edges: Beveled

PART 3 EXECUTION

3.01 INSTALLATION

- A. General: In accordance with the manufacturer's recommendations, National Gypsum Company "Gypsum Construction Guide."

Gold Bond® BRAND 1" Fire-Shield® Shaftliner XP®

DESCRIPTION

Shaftliner XP™ Gypsum Panels consist of a mold and fire-resistant type X gypsum core encased in a heavy moisture/mold/mildew-resistant, 100% recycled purple paper on the face and back sides. Shaftliner XP was designed to provide extra protection against mold and mildew. The face paper is folded around the long edges to reinforce and protect the core, and the ends are square-cut and finished smooth. Long edges of panels are beveled for ease of installation.

1" Shaftliner XP Panels are designed to be used to construct lightweight fire barriers for cavity shaft walls and area separation walls in multifamily housing. The panels are key components in Cavity Shaftwall Systems and H-Stud Area Separation Wall Systems.

TECHNICAL DATA

SURFACE BURNING CHARACTERISTICS

ASTM E84
Flame Spread: 15
Smoke Developed: 0

WEIGHT

1" XP - 3.75 lbs/SF

FIRE RESISTANCE RATINGS

Fire resistance ratings represent the results of tests on assemblies made up of materials authorized by National Gypsum in specific configurations. When selecting construction designs to meet certain fire requirements, caution must be used to ensure that each component of the assembly is the one specified in the test. Further, precaution should be taken that assembly procedures are in accordance with those of the tested assembly. (For copies of specific tests, call 1-800-NATIONAL)

MOLD AND MILDEW RESISTANCE

Shaftliner XP was designed to provide extra protection against mold and mildew.

When tested by an independent lab per ASTM D3273 (Standard Test Method for Resistance to Growth of Mold on the Surface of Interior Coatings in an Environmental Chamber), Shaftliner XP achieved a score of 10, the best possible score for this test.

The use of Shaftliner XP in actual installations may not produce the same results as were achieved in controlled, laboratory conditions. No material can be considered "mold proof," nor is it certain that any material will resist mold indefinitely. When used in conjunction with good design, handling and construction practices, Shaftliner XP can provide increased mold resistance versus standard shaftliner products. As with any building material, avoiding water exposure during handling, storage and installation, and after installation is complete, is the best way to avoid the formation of mold or mildew.

RECOMMENDATIONS

Installation of 1" Shaftliner XP Gypsum Panels should be consistent with methods described in specific application details for Cavity Shaftwall Systems, or H-Stud Area Separation Wall Systems, or other fire-rated designs shown in National Gypsum Company "Gypsum Construction Guide."

Exposure to excessive or continuous moisture or standing water and extreme temperatures should be avoided.

To prevent weakening due to calcining, 1" Fire-Shield Shaftliner panels, like any gypsum board, should not be exposed to temperatures over 125°F (52°C) for extended periods of time.

Not to be used in an unlined air supply duct.

Always store Shaftliner XP Gypsum Panels flat on a level surface, and support with properly placed risers. to Growth of Mold on the Surface of Interior Coatings.

Care should be taken to avoid impact, unwarranted flexing and subsequent damage to board edges, ends and corners.

Shaftliner XP may be substituted for National Gypsum's Gold Bold BRAND Fire-Shield Shaftliner in Cavity Shaftwall, Area Separation Wall Systems and solid laminated partitions.

SPECIFICATIONS

THE FOLLOWING PARAGRAPHS ARE FOR INSERTION INTO SECTIONS OF GENERIC SPECIFICATIONS OR GENERIC/PROPRIETARY SPECIFICATIONS COVERING GYPSUM BOARD PRODUCTS. THE NATIONAL GYPSUM PRODUCT NAME FOLLOWS THE GENERIC DESCRIPTION IN PARENTHESES.

PART 2 PRODUCTS

2.01 MATERIALS

A. Fire and Mold-Resistant Gypsum Shaftliner Board: A gypsum core shaftwall board with additives to enhance fire resistance of the core and surfaced with a moisture/mold/mildew resistant paper on front, back and long edges; and complying with ASTM C1396, Type X (Gold Bond BRAND Fire-Shield Shaftliner XP).

1. Thickness: 1"
2. Width: 2'
3. Length: 7' through 14'
4. Edges: Beveled
5. Mold and Mildew Resistance: Panel score of 10 when tested in accordance with ASTM D3273.

PART 3 EXECUTION

3.01 INSTALLATION

A. General: In accordance with the manufacturer's recommendations, National Gypsum Company "Gypsum Construction Guide."

DESCRIPTION

Gold Bond BRAND High Flex Gypsum Board consists of a fire-resistive gypsum core encased in heavy natural-finish paper on the face side and strong liner paper on the back side. The face paper is folded around the long edges to reinforce and protect the core and the ends are square-cut and finished smooth. Long edges of boards are slightly tapered, allowing joints to be reinforced and concealed with ProForm Joint Tape and Joint Treatment Compounds.

1/4" High Flex Gypsum Board is specifically designed for radius construction such as curved walls, archways and stairways. It can be used for both concave and convex surfaces. 1/4" High Flex is typically applied in double layers.

1/4" High Flex Gypsum Board is a lightweight, cost-efficient material that readily accepts a wide range of decorative finishes.

1/4" High Flex Gypsum Board is easily cut for quick installation, permitting painting or other decoration and the installation of metal or wood trim almost immediately.

The gypsum core is non-combustible.

With joints reinforced by ProForm BRAND Joint Compounds, Gold Bond Gypsum Board forms walls and ceilings exceptionally resistant to cracks caused by structural and thermal changes.

Expansion and contraction under normal atmospheric changes is negligible.

TECHNICAL DATA

SURFACE BURNING CHARACTERISTICS

ASTM E 84
Flame spread: 15
Smoke developed: 0

WEIGHT

1/4" High Flex - .95 lbs/SF

RECOMMENDATIONS

Installation of Gold Bond BRAND gypsum board should be consistent with methods described in GA216

"Recommended Specifications for the Application of Gypsum Board," ASTM C 840, "Standard Specifications for Application and Finishing of Gypsum Board," and GA214, "Recommended Levels of Gypsum Board Finish."

Exposure to extreme temperatures should be avoided. 1/4" High Flex Gypsum Board is not recommended where it will be exposed to temperatures exceeding 125°F.

Installing 1/4" High Flex Gypsum Board over an insulating blanket, installed continuously across the face of the framing members, is not recommended. Blankets should be recessed and flanges attached to the sides of the studs or joists.

For best painting results, all surfaces, including joint compound, should be clean, dust-free and not glossy. To improve fastener and joint concealment, a coat of a quality latex primer is recommended to equalize the absorption between surface paper and joint compound.

1/4" High Flex Gypsum Board should be applied first to ceiling at right angles to framing members, then to walls. Boards of maximum practical length should be used so that an absolute minimum number of end joints occur. Board edges should be brought into contact with each other but should not be forced into place.

1/4" High Flex Gypsum Board is significantly more flexible in the vertical direction (long edges parallel to the framing) than in the horizontal direction. (See Table 1.)

Gypsum board joints at openings should be located so that no end joint will align with edges of openings unless control joints will be installed at these points. End joints should be staggered, and joints on opposite sides of a partition should not occur on the same stud.

1/4" High Flex Gypsum Board is typically installed in double layer construction. To prevent flat spots, framing members should be

spaced closer together than required for typical flat wall and ceiling surfaces (see Table 1). 1/4" High Flex Gypsum Board should be held in firm contact with the framing member while fasteners are being driven.

For concave surfaces, a stop shall be applied to one end of the curve to restrain one end or edge of the board during installation. Pressure shall be applied to the unrestrained end or edge of the gypsum board forcing the field of the gypsum board into firm contact with the framing. Gypsum board shall be fastened by working from the "stopped" end or edge. The gypsum board shall be held tightly against the framing while fasteners are being driven.

For convex surfaces, one end of the gypsum board shall be attached to the framing with nails or screws. The gypsum board shall be progressively pushed into contact with the framing members, working from the fixed end to the free end. The gypsum board shall be held tightly against each framing member while fasteners are being driven.

Fasteners should be set with the heads slightly below the surface of the gypsum board in a dimple formed by the hammer or power screwdriver. Care should be taken to avoid breaking the face paper of the gypsum board. Improperly driven nails or screws should be removed.

Table 1

MINIMUM BENDING RADII FOR 1/4" HIGH FLEX GYPSUM BOARD

Application	Lengthwise		Widthwise	
	Bend Radii	Max. Stud Spacing	Bend Radii	Max. Stud Spacing
Inside (Concave) Dry	32"	9" o.c.	20"	9" o.c.
Outside (Convex) Dry	30"	9" o.c.	15"	8" o.c.
Inside (Concave) Wet	20"	9" o.c.	10"	6" o.c.
Outside (Convex) Wet	14"	6" o.c.	7"	5" o.c.

Lengthwise denotes long edges perpendicular to the framing members. Widthwise denotes long edges parallel to the framing members. The values listed in Table 1 were achieved at 65° F and 45% relative humidity. Lower temperatures and lower humidity will decrease the flexibility.

Wetting the board is only required on extremely tight radii, or when temperature and humidity conditions are lower than 65° F and 45% relative humidity. When wetting the board, apply 10-15 ounces of clean water per side with a paint roller or sprayer. Allow to soak 10-15 minutes before bending.



SPECIFICATIONS

THE FOLLOWING PARAGRAPHS ARE FOR INSERTION INTO SECTIONS OF GENERIC SPECIFICATIONS OR GENERIC/PROPRIETARY SPECIFICATIONS COVERING GYPSUM BOARD PRODUCTS. THE NATIONAL GYPSUM PRODUCT NAME FOLLOWS THE GENERIC DESCRIPTION IN PARENTHESES.

PART 2 PRODUCTS

2.01 MATERIALS

- A. Flexible Gypsum Board:
A gypsum core wall board with additives to enhance flexibility surfaced with paper on front, back and long edges and complying with ASTM C 1396. (High Flex BRAND Gypsum Board).
1. Thickness: 1/4"
 2. Width: 4'
 3. Length: 8' through 12'
 4. Edges: Slightly tapered

PART 3 EXECUTION

3.01 INSTALLATION

- A. General: In accordance with the manufacturer's recommendations, National Gypsum Company "*Gypsum Construction Guide.*"



DESCRIPTION

Gold Bond BRAND High Strength Ceiling Board is a specialty gypsum board with increased uniformity and integrity of its gypsum core, making its sag resistance equivalent to 5/8" type X gypsum board.

1/2" High Strength Ceiling Board is specifically designed for ceilings where framing members are spaced up to 24" o.c. and a water-based texture will be used.

1/2" High Strength Ceiling Board is available nationwide as a stocked item at all National Gypsum plants.

Excellent working characteristics, improved score and snap properties reduce the need for rasping.

Excellent sag resistance. Witnessed test results show overall sag on tested assembly to be equivalent to 5/8" type X gypsum board. Test report available upon request.

Eliminates need for two board sizes on the job. Scrap from ceiling is reduced since this material also can be used on the walls.

TECHNICAL DATA

In independent tests, High Strength Ceiling Board exhibited an average sag of only .033 (approx. 1/32") on joists spaced 24" on center with a spray texture applied. This test was conducted over one month at temperatures between 66°-79°F (19°C-26°C) and relative humidities between 30%-60%. (Reference: PSI report #722600-R71 March 25, 1991)

Under the strict ASTM C-473 Physical Testing for Humidified Deflection, Gold Bond BRAND 1/2" High Strength Ceiling Board exhibited sag-resistant properties equal to 5/8" type X gypsum board.

SURFACE BURNING CHARACTERISTICS

ASTM E 84

Flame spread index: 15

Smoke developed: 0

WEIGHT

1/2" Hi Strength - 1.8 lbs/SF

RECOMMENDATIONS

Installation of Gold Bond BRAND Gypsum Board should be consistent with methods described in, GA216, "Recommended Specifications for the Application of Gypsum Board," ASTM C 840, "Standard Specification for Application and Finishing of Gypsum Board."

Not recommended in areas of continuous high humidity such as saunas, steam rooms, gang shower rooms, and indoor pool enclosures. Prime with sealing latex primer and allow to dry thoroughly. Apply insulation and polyethylene vapor barrier (if used) before installing ceiling board. Insulation not to exceed 2.2 lbs./square foot (10.7 kg/m²). Adequate ventilation required.

1/2" High Strength Ceiling Board must be stored off the ground and under cover. Sufficient risers must be used to ensure support for the entire length of the gypsum board to prevent sagging.

Not to be exposed to temperatures exceeding 125°F (52°C) for extended periods of time.

Installing gypsum board over an insulating blanket, installed continuously across the face of the framing members, is not recommended. Blankets should be recessed and flanges attached to the sides of the studs or joists.

DECORATION

For best painting results, all surfaces, including joint compound, should be clean, dust-free and not glossy. To improve fastener and joint concealment, a coat of a quality primer is recommended to equalize the porosities between surface paper and joint compound. Drywall primer is a product specially formulated for this purpose.

The selection of a paint to give the specified or desired finished characteristics is the responsibility of the architect or contractor.

Gypsum board that is to have a wallcovering applied to it should be prepared and primed as described for painting.



Gypsum Association GA-214, Recommended Specification for Levels of Gypsum Board Finish, should be referred to in order to determine the level of finishing needed to ensure a surface properly prepared to accept the desired decoration.

SS-L-30D type III, Grade R, Class 1. (Gold Bond BRAND High Strength Ceiling Board).

1. Thickness: 1/2"

2. Width: 4'

3. Length: 6' through 16'

4. Edge: Tapered

SPECIFICATIONS

THE FOLLOWING PARAGRAPHS ARE FOR INSERTION INTO SECTIONS OF GENERIC SPECIFICATIONS OR GENERIC/PROPRIETARY SPECIFICATIONS COVERING GYPSUM BOARD PRODUCTS. THE NATIONAL GYPSUM PRODUCT NAME FOLLOWS THE GENERIC DESCRIPTION IN PARENTHESES.

PART 2 PRODUCTS

2.01 MATERIALS

- A. Gypsum Ceiling Board: A gypsum core ceiling board with additives to enhance the sag resistance of the core and surfaced with paper on front, back, and long edges, complying with ASTM C 1396 and Federal specification

PART 3 EXECUTION

3.01 INSTALLATION

- A. General: In accordance with the manufacturer's recommendations, National Gypsum Company "Gypsum Construction Guide."

Gold Bond® BRAND Hi-Abuse XP® Gypsum Board

DESCRIPTION

Gold Bond® BRAND Hi-Abuse XP® Gypsum Board panels consist of a mold and fire resistant type x gypsum core encased in heavy mooth abrasion resistant, moisture, mold/mildew-resistant, 100% recycled purple paper on the face side and heavy mold/mildew-resistant liner paper on the back side. Hi-Abuse XP Gypsum Board is designed to provide extra protection against mold and mildew compared to standard gypsum board products. The panels feature a specifically formulated core to provide greater resistance to surface indentation and impact than fiber-reinforced gypsum panels. Long edges of the panels are tapered. Tapered edges allow joints to be treated in the normal manner. For optimum mold and mildew resistance, National Gypsum recommends ProForm BRAND XP Ready Mix, or Sta-Smooth/Sta-Smooth Lite setting compounds.

TECHNICAL DATA



Walls and ceilings in school corridors and cafeterias are ideal applications for Gold Bond® BRAND Hi-Abuse XP® Gypsum Board.

Surface Abrasion Test ASTM – D 4977 (Modified)		
	5/8" Hi-Abuse XP	5/8" Gypsum Board Type X
Mean Depth Abrasion	0.009 in.	0.576 in.
Performance Classification	Level 3	Does Not Qualify

Procedure Summary – A sample is laid flat and subjected to 50 abrasion cycles of a wire brush with additional 25 lbs. weight. The depth of abrasion in three consecutive samples is measured and reported as a mean depth of abrasion in inches. This test measures the ability of a panel to withstand surface scuffs and abrasions.

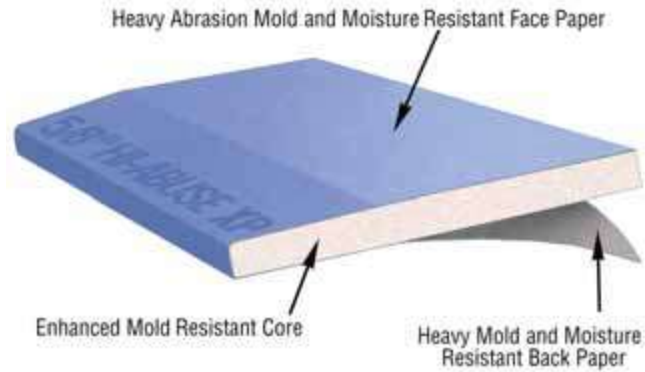
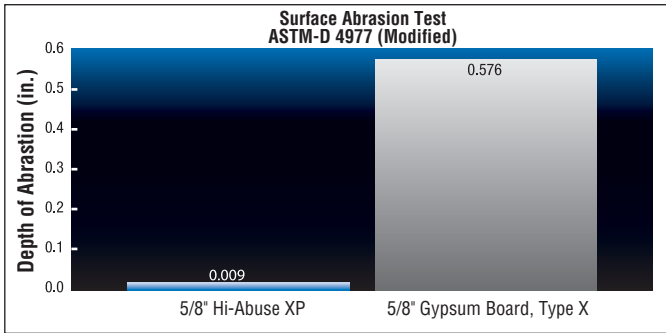

Single Drop Soft Body Impact Test Modified ASTM – E 695 (Modified)		
	5/8" Hi-Abuse XP	5/8" Gypsum Board Type X
Ft.-Lbs. required to penetrate	210	120
Performance Classification	Level 2	Level 1

Procedure Summary – This test is conducted with a leather bag loaded with steel pellets to a weight of 60 lbs. The bag is suspended by a rope and dropped at an angular distance until specimen is impacted.

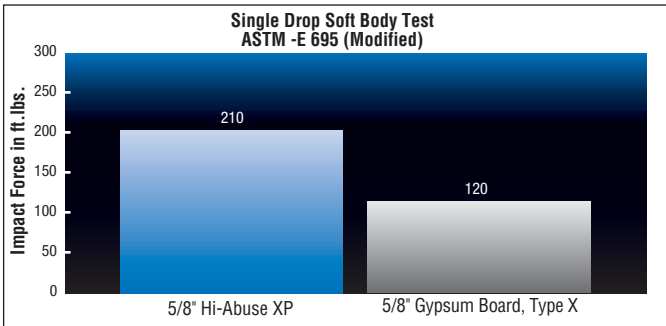

Surface Indentation Resistance Modified ASTM – D 5420 (Gardner Impact)		
	5/8" Hi-Abuse XP	5/8" Gypsum Board Type X
Mean Depth of indentation	0.132 in.	0.230 in.
Performance Classification	Level 1	Does Not Qualify

Procedure Summary – A sample is laid flat and impacted by a 5/8" hemispherical rod raised to height that provides 72 in.-lbs. of impact energy. The depth of the indentation is measured from three board samples and reported as a mean depth of indentation in inches. This test measures the ability for a panel to resist dents.

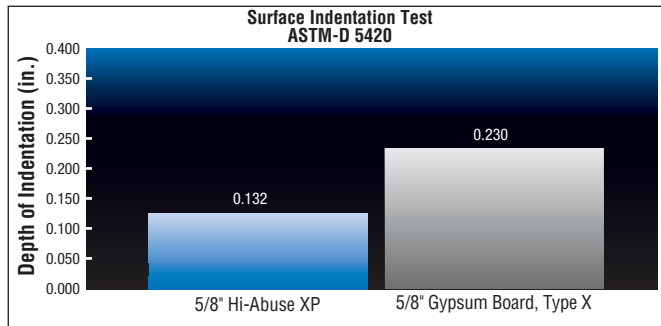

SURFACE BURNING CHARACTERISTICS

ASTM E 84
Flame spread (Face): 15
Smoke developed: 0

WEIGHT

1/2" Hi-Abuse XP - 2.4 lbs/SF
5/8" Type X Hi-Abuse - 2.8 lbs/SF

FIRE RESISTANCE RATINGS

Fire resistance ratings represent the results of tests on assemblies made up of specific materials in a specific configuration. When selecting construction designs to meet certain fire resistance requirements, caution must be used to ensure that each component of the assembly is the one specified in the test. Further, precaution should be taken that assembly procedures are in accordance with those of the tested assembly. (For copies of specific tests, call 1-800-NATIONAL.)

MOLD AND MILDEW RESISTANCE

Hi-Abuse® BRAND XP Gypsum Board has been designed to provide extra protection against mold and mildew compared to standard gypsum board products. When tested by an independent lab per ASTM D3273 ("Standard Test Method for Resistance to Growth of Mold On the Surface of Interior Coatings in an Environmental Chamber"), Hi-Abuse XP Gypsum Board achieved a score of 10, the best possible score for this test.

The use of Hi-Abuse XP Gypsum Board in actual installations may not produce the same results as were achieved in controlled, laboratory conditions. No material can be considered "mold proof," nor is it certain any material will resist mold or mildew indefinitely. When used in conjunction with good design, handling and construction practices, Hi-Abuse XP Gypsum Board can provide increased mold resistance versus standard gypsum board products. As with any building material, avoiding water exposure during handling, storage and installation, and after installation is complete, is the best way to avoid the formation of mold or mildew.

RECOMMENDATIONS

Installation of Hi-Abuse XP Gypsum Board should be consistent with methods described in the standards references noted. For best performance, use vertical application.

GridMarX®

Hi-Abuse® BRAND XP Gypsum Board comes standard with GridMarX® guide marks printed on the paper surface. These guide marks align with standard building dimensions and help to quickly identify fastener lines for stud and joist framing. Using GridMarX, accurate cuts can be made without having to draw lines. The use of GridMarX also provides quick identification and uniform nail/screw patterns.

GridMarX guide marks run the machine direction of the board at five points in 4" increments. Marks run along the edge in both tapers and at 16", 24" and 32" in the field of the board. The marks cover easily with no bleed-through using standard products.

Vertical Application - In a vertical application, GridMarX serves as a **guide mark** to help identify the exact location of framing members behind the gypsum board, eliminating the need for field-applied vertical lines.

Horizontal Application - In a horizontal application, GridMarX serves as a **reference mark** to help identify the location of framing members behind the gypsum board. (If framing member is located 2" to the right of the GridMarX at the top edge of the board, it will be located 2" to the right down the face of the board.)

Provides greater resistance to surface abuse, indentation and impact than fiber-reinforced gypsum panels.

Hi-Abuse XP smooth face paper is highly resistant to scuffing when sanding gypsum board joints and fasteners providing a superior surface for decoration.

Hi-Abuse XP Gypsum Board is easily scored and snapped for quick installation. Openings and outlet boxes are cut out in same manner as regular gypsum board.

Minimum bending radii for 5/8" Hi-Abuse XP Gypsum Board is 20'-0" applied lengthwise perpendicular to framing spaced not greater than 12" on center.

Lightweight, cost-efficient material that readily accepts a wide range of decorative finishes.

The gypsum core will not support combustion or transmit temperatures greatly in excess of 212°F (100°C) until completely calcined, a slow process.

Expansion and contraction under normal atmospheric changes are negligible.

Hi-Abuse XP 5/8" Fire-Shield panels may be used where Type X gypsum panels are specified in fire-rated wall and floor-ceiling assemblies (i.e. UL, U300, U400, V400 and L500 series.)

Exposure to excessive or continuous moisture and extreme temperatures should be avoided. Hi-Abuse XP Gypsum Board is not recommended where it will be exposed to temperatures exceeding 125°F (52°C) for extended periods of time.

Hi-Abuse XP Gypsum Board shall not be used where there will be direct exposure to water or continuous high humidity conditions, such as found in tub and shower enclosures, saunas, steam rooms and gang showers. If the area is to be exposed to water or continuous high humidity, National Gypsum's PermaBase® BRAND Cement Board should be used.

Hi-Abuse XP Gypsum Board must be stored off the ground and under cover. Sufficient risers must be used to ensure support for the entire length of the gypsum board to prevent sagging.

Hi-Abuse XP Gypsum Board must be kept dry to minimize the potential for mold growth. Adequate care should be taken while transporting, storing, applying and maintaining gypsum board. For additional information, refer to the Gypsum Association publication, "Guidelines for the Prevention of Mold Growth on Gypsum Board" (GA-238-03), which is available at www.gypsum.org under the "Download Free Gypsum Association Publications" section.

DECORATION

For best painting results, all surfaces, including joint compound, should be clean, dust-free and not glossy. To improve fastener and joint concealment, a coat of a quality drywall primer is recommended to equalize the porosities between surface and joint compound.

The selection of a paint to give the specified or desired finished characteristics is the responsibility of the architect or contractor.

Hi-Abuse XP Gypsum Board that is to have a wall covering applied to it should be prepared and primed as described for painting.

Gypsum Association GA-214, "Recommended Specifications for Levels of Gypsum Board Finish," should be referred to in order to determine the level of finishing needed to ensure a surface properly prepared to accept the desired decoration.

SPECIFICATIONS

THE FOLLOWING PARAGRAPHS ARE FOR INSERTIONS INTO SECTIONS OF GENERIC SPECIFICATIONS OR GENERIC/PROPRIETARY SPECIFICATIONS COVERING GYPSUM BOARD PRODUCTS. THE NATIONAL GYPSUM PRODUCT NAME FOLLOWS THE GENERIC DESCRIPTION IN PARENTHESES.

PART 2 PRODUCTS

2.01 MATERIALS

A. Fire, Abuse and Mold Resistant Gypsum Board: A gypsum core wall panel with additives to enhance fire resistance, surface indentation resistance and impact resistance of the core and surfaced with abrasion, moisture/mold/mildew resistant paper on front, back and long edges; and complying with ASTM C 1396 Type X (Hi-Abuse BRAND XP Fire-Shield Gypsum Board).

1. Thickness: 5/8"
2. Width: 4'
3. Length: 8' through 12'
4. Edges: Tapered
5. Surface Abrasion Resistance: Not greater than 0.009 depth when tested at 50 cycles in accordance with ASTM D 4977, modified.
6. Indentation Resistance: Not greater than 0.132" depth when tested at an impact load of 72 in.-lbs. In accordance with ASTM D 5420.
7. Impact/Penetration Resistance: Not less than 210 ft.-lbs. required to penetrate when tested in accordance with ASTM E 695, modified.
8. Mold/Mildew Resistance: Panel score of 10 when tested in accordance with ASTM D 3273.

PART 3 EXECUTION

3.01 INSTALLATION

A. General: In accordance with the manufacturer's recommendations, National Gypsum Company "Gypsum Construction Guide."

DESCRIPTION

Gold Bond® BRAND Hi-Impact XP® Gypsum Board panels consist of a mold, moisture and fire resistant type X gypsum core encased in heavy, smooth, abrasion-resistant, mold/mildew-resistant, 100% recycled purple paper on the face side and heavy mold/mildew resistant liner paper on the back side. A fiberglass mesh is embedded in the core, close to the back of the board to provide additional impact/penetration resistance. Hi-Impact XP Gypsum Board features a specially formulated core to provide fire resistance ratings when used in tested systems in addition to providing extra protection against mold and mildew compared to standard gypsum board products. Long edges of panels are tapered. Tapered edges allow joints to be treated in the normal manner. For optimum mold and mildew resistance, National Gypsum recommends ProForm BRAND XP Ready Mix, or Sta-Smooth/Sta-Smooth Lite compounds.

TECHNICAL DATA

Surface Abrasion ASTM – D 4977 (Modified)		
	5/8" Hi-Impact XP with Fiberglass Scrim	5/8" Gypsum Board Type X
Mean Depth Abrasion	0.009 in.	0.576 in.
Performance Classification	Level 3	Does Not Qualify
Procedure Summary – A sample is laid flat and subjected to 50 abrasion cycles of a wire brush with additional 25 lbs. weight. The depth of abrasion in three consecutive samples is measured and reported as a mean depth of abrasion in inches. This test measures the ability of a panel to withstand surface scuffs and abrasions.		

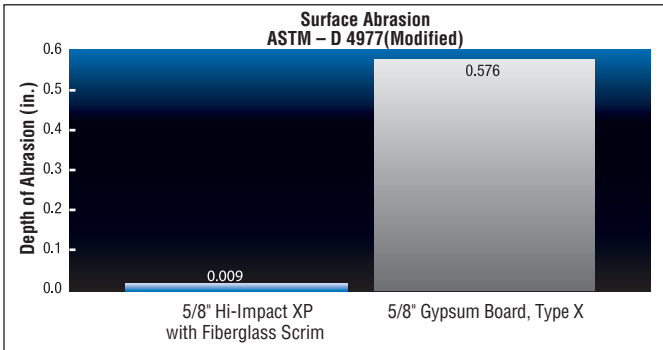

Single Drop Soft Body Impact Test ASTM – E 695 (Modified)		
	5/8" Hi-Impact XP with Fiberglass Scrim	5/8" Gypsum Board Type X
Ft.-lbs. required to penetrate	>540*	120
Performance Classification	Level 3	Level 1
Procedure Summary – This test is conducted with a leather bag loaded with steel pellets to a weight of 120 lbs. The bag is suspended by a rope and dropped at an angular distance until specimen is impacted.* In the test the framing collapsed without failure to the Hi-Impact panels.		

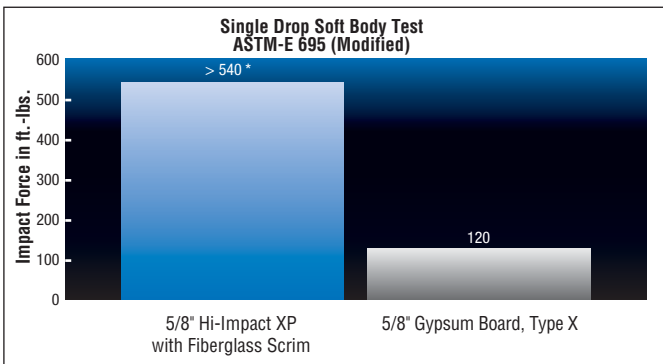

Prison walls have to be strong. And, with GOLD BOND® BRAND Hi-Impact XP® Gypsum Board, strong walls can be installed as easily as regular gypsum board.

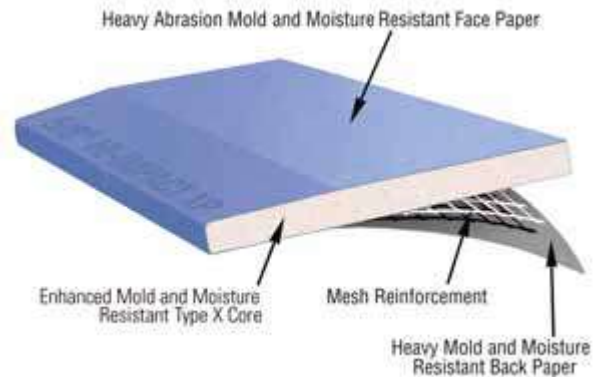

Surface Indentation Test ASTM – D 5420 (Gardner Impact)		
	5/8" Hi-Impact XP with Fiberglass Scrim	5/8" Gypsum Board Type X
Mean Depth of indentation	0.114 in.	0.230 in.
Performance Classification	Level 1	Does Not Qualify
Procedure Summary – A sample is laid flat and impacted by a 5/8" hemispherical rod raised to height that provides 72 in.-lbs. of impact energy. The depth of the indentation is measured from three board samples and reported as a mean depth of indentation in inches. This test measures the ability for a panel to resist dents.		

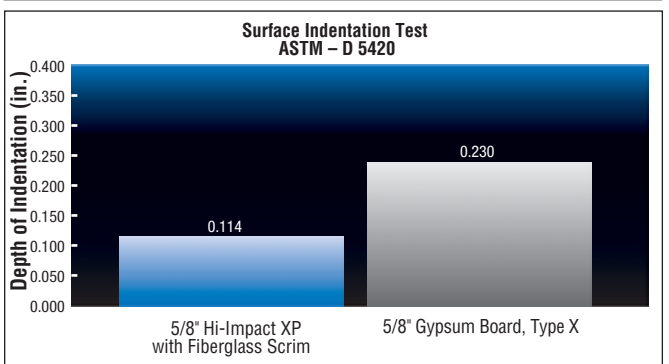

09 29 00

Hard Body Impact - ASTM C 1629		
	5/8" Hi-Impact XP with Fiberglass Scrim	5/8" Gypsum Board Type X
Ft.-lbs. to penetrate into cavity	>160	35
Performance Classification	Level 3	Does Not Qualify
Procedure Summary – A 2' x 2' board sample is mounted to a 3-5/8", 20 gauge steel frame and runners using drywall screws. The sample is impacted with a ram mounted on a pendulum which is faced with a 2-3/4" steel cylinder dropped from a fixed height. Weights are added to increase the impacting energy. The maximum impact force that the sample can withstand without penetration through the sample and into the stud cavity is reported in foot-pounds. This test measures the ability to withstand the impact of a hard object such as a hammer or heel of a boot.		

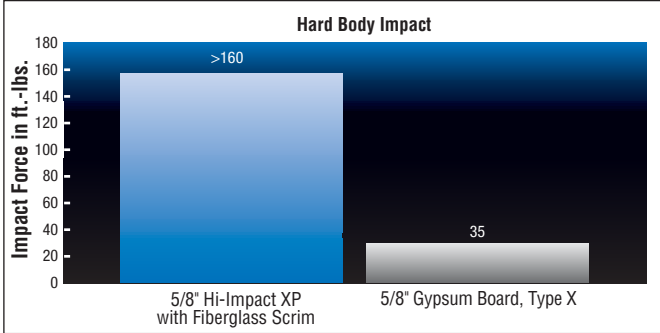

Water Absorption ASTM C 473		
	5/8" High-Impact XP with Fiberglass Scrim	5/8" Gypsum Board Type X
Percentage of Weight Gained	4%	47%
Procedure Summary – Three dry board samples were cut and weighed. Each sample was then submerged in a 3-inch water bath for two hours. The samples were removed, wiped and weighed again. The weight gained is calculated and reported as a percentage. The higher the percentage the more water the panel absorbed.		

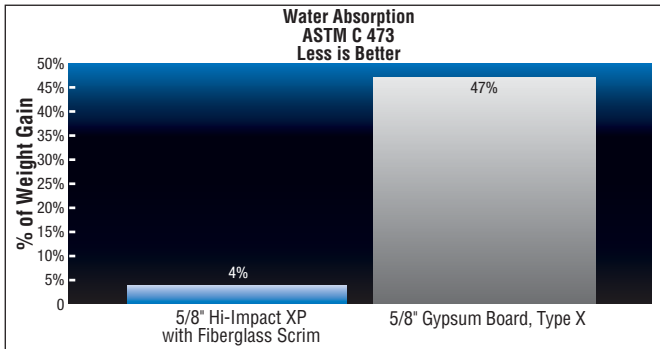

SURFACE BURNING CHARACTERISTICS

ASTM E 84
(Face)
Flame spread: 15
Smoke developed: 0

WEIGHT

5/8" Hi-Impact XP - 2.8 lbs/5F

MOLD AND MILDEW RESISTANCE

Hi-Impact® XP Gypsum Board has been designed to provide extra protection against mold and mildew compared to standard gypsum board products. When tested by an independent lab per ASTM D3273 ("Standard Test Method for Resistance to Growth of Mold On the Surface of Interior Coatings in an Environmental Chamber"), Hi-Impact XP Gypsum Board achieved a score of 10, the best possible score for this test.

The use of Hi-Impact XP Gypsum Board in actual installations may not produce the same results as were achieved in controlled,

laboratory conditions. No material can be considered "mold proof," nor is it certain any material will resist mold or mildew indefinitely. When used in conjunction with good design, handling and construction practices, Hi-Impact XP Gypsum Board can provide increased mold resistance versus standard gypsum board products. As with any building material, avoiding water exposure during handling, storage and installation, and after installation is complete, is the best way to avoid the formation of mold or mildew.

FIRE RESISTANCE RATINGS

Fire resistance ratings represent the results of tests on assemblies made up of specific configuration. When selecting construction designs to meet certain fire resistance requirements, caution must be used to ensure that each component of the assembly is the one

specified in the test. Further precaution should be taken specified in the test. Further precaution should be taken that assembly procedures are in accordance with those of the tested assembly. (For copies of specific tests, call 1-800-NATIONAL.)

FIRE ENDURANCE

- 1-Hour Rating: Hi-Impact XP Gypsum Board screw attached vertically to both sides of 20 gauge 3-5/8" studs spaced 16" o.c. with 1-1/4" long, type S screws spaced 8" o.c. along edges and 12" o.c. in the field of the board. Gypsum board joints staggered. UL U465
- 2-Hour Rating: Constructed with a base layer of Hi-Impact XP Gypsum Board with an additional layer of 5/8" Fire-Shield Gypsum Board Type X screw attached vertically to both sides of 20 gauge 3-5/8" studs spaced 16" o.c. with joints staggered between face and base layer. Base layer attached with 1-1/4" long type S screws spaced 8" o.c. along edges and 12" o.c. in the field of the board. Outer layer attached with 2-1/2" long type S screws spaced 8" o.c. in the field and along vertical edges and to the floor and ceiling runners. UL U411

For additional UL Design Listings, please reference the UL Directory.

RECOMMENDATIONS

Installation of 5/8" Hi-Impact XP Fire-Shield Type X Gypsum Board should be consistent with methods described in Applicable Standards with one exception - for best results, cutting and scoring of Hi-Impact XP should be from the back side of the board.

GridMarX®

Hi-Impact XP Gypsum Board comes standard with GridMarX® guide marks printed on the paper surface. These guide marks align with standard building dimensions and help to quickly identify fastener lines for stud and joist framing. Using GridMarX, accurate cuts can be made without having to draw lines. The use of GridMarX also provides quick identification and uniform nail/screw patterns.

GridMarX guide marks run the machine direction of the board at five points in 4" increments. Marks run along the edge in both tapers and at 16", 24" and 32" in the field of the board. The marks

at 16", 24" and 32" in the field of the board. The marks cover easily with no bleed-through using standard products.

Vertical Application - In a vertical application, GridMarX serves as a **guide mark** to help identify the exact location of framing members behind the gypsum board, eliminating the need for field-applied vertical lines.

Horizontal Application - In a horizontal application, GridMarX serves as a **reference mark** to help identify the location of framing members behind the gypsum board. (If framing member is located 2" to the right of the GridMarX at the top edge of the board, it will be located 2" to the right down the face of the board.)

Hi-Impact XP Gypsum Board can be used as a tile backer board in dry areas and areas with limited water exposures such as toilet/sink areas and areas above tile in tubs and showers

Hi-Impact XP Gypsum Board should not be used as a backer board directly behind tile in tub and shower areas.

Hi-Impact XP should not be used in areas subject to constant and/or excessive moisture and high humidity such as gang showers, saunas, steam rooms and swimming pool enclosures. PermaBase BRAND cement board is recommended for these areas.

Hi-Impact XP Gypsum Board can be used on the interior side of exterior walls in hot, humid climates such as the Southern Atlantic and Gulf Coast areas.

Hi-Impact XP Gypsum Board features a type X core to provide additional fire resistance when used in tested systems.

Hi-Impact XP Gypsum Board is easily cut for quick installation, permitting painting or other decoration and the installation of most metal or wood trim almost immediately.

Minimum bending radii for 5/8" Hi-Impact XP Gypsum Board is 20'-0" applied lengthwise perpendicular to framing spaced not greater than 12" on center.

The gypsum core will not support combustion or transmit temperatures greatly in excess of 212°F (100°C) until completely calcined, a slow process.

Exposure to excessive or continuous moisture and extreme temperatures should be avoided.

Listed impact/penetration ratings apply to walls constructed with Hi-Impact XP Gypsum Board applied with long edges parallel to and centered over minimum 20 gauge framing members spaced a maximum of 16" o.c.

Hi-Impact XP Gypsum Board must be stored off the ground and under cover. Sufficient risers must be used to ensure support for the entire length of the gypsum board to prevent sagging.

Hi-Impact XP Gypsum Board must be kept dry to minimize the potential for mold growth. Adequate care should be taken while transporting, storing, applying and maintaining gypsum board. For additional information, refer to the Gypsum Association publication, "Guidelines for the Prevention of Mold Growth on Gypsum Board" (GA-238-03), which is available at www.gypsum.org under the "Download Free Gypsum Association Publications" section.

DECORATION

For best painting results, all surfaces, including joint compound, should be clean, dust-free and not glossy. To improve fastener and joint concealment, a coat of high quality latex primer is recommended to equalize the absorption between surface paper and joint compound. Drywall primer is specially formulated for this purpose.

The selection of a paint to give the specified or desired finished characteristics is the responsibility of the architect or contractor.

Hi-Impact XP Gypsum Board that is to have a wall covering applied to it should be prepared and primed as described for painting.

Gypsum Association GA-214, "Recommended Specification for Levels of Gypsum Board Finish," should be referred to in order to determine the level of finishing needed to ensure a surface properly prepared to accept the desired decoration.

SPECIFICATIONS

THE FOLLOWING PARAGRAPHS ARE FOR INSERTION INTO SECTIONS OF GENERIC SPECIFICATIONS FOR GENERIC/PROPRIETARY SPECIFICATIONS COVERING GYPSUM BOARD PRODUCTS. THE NATIONAL GYPSUM PRODUCT NAME FOLLOWS THE GENERIC DESCRIPTION IN PARENTHESES.

PART 2 PRODUCTS

2.01 MATERIALS

A. Fire, Impact/Penetration and Mold-Resistant Gypsum Board: A gypsum core wall panel with additives to enhance the fire and resistance, and mold/mildew resistance of the core; surfaced with abrasion/moisture/mold/mildew resistant paper on the front, back and long edges with a fiberglass mesh embedded in the board to enhance impact/penetration resistance and complying with ASTM C 1396, Type X. (Gold Bond BRAND Hi-Impact XP Fire-Shield Gypsum Board).

1. Thickness: 5/8"
2. Width: 4'
3. Length: 8' through 12'
4. Edges: Tapered

5. Surface Abrasion Resistance: Not greater than 0.009" depth when tested at 50 cycles in accordance with ASTM D 4977, Modified.
6. Indentation Resistance: Not greater than 0.114" depth when tested at an impact load of 72 in.-lbs. in accordance with ASTM D 5420.
7. Impact/Penetration Resistance: Not less than 720 ft.-lbs. required to penetrate when tested in accordance with ASTM E 695, Modified.
8. Mold/Mildew Resistance: Panel score of 10 when tested in accordance with ASTM D 3273.

PART 3 EXECUTION

3.01 INSTALLATION

- A. General: In accordance with the manufacturer's recommendations, National Gypsum Company "Gypsum Construction Guide."

GOLD BOND® BRAND SoundBreak™ Gypsum Board

DESCRIPTION

Gold Bond® BRAND SoundBreak™ Gypsum Board is an acoustically enhanced gypsum board used in the construction of high rated STC wall assemblies. This 5/8" thick gypsum board consists of a layer of viscoelastic damping polymer sandwiched between two pieces of enhanced high density mold resistant gypsum board, providing constrained layer damping.

For speed of installations, GridMarX® guide marks are printed on the paper surface.

Long edges of the panels are tapered. Tapered edges allow joints to be reinforced with ProForm® BRAND Joint Tape and concealed with ProForm® BRAND Ready Mix, Easy Finish® BRAND Ready Mix or ProForm® BRAND Sta-Smooth® Joint Compounds. For optimum mold and mildew performance, National Gypsum recommends ProForm® BRAND XP® Ready Mix.

Use of SoundBreak Gypsum Board results in wall partitions with high rated STC values that are thinner than traditionally built high rated STC wall partitions, providing increased usable floor space.

Superior sound damping, cost-efficient material that is easily finished and decorated in the same manner as regular gypsum board.

All SoundBreak Gypsum Board designs were tested by an independent third-party acoustical laboratory using the full scale ASTM E90 test procedure.

SoundBreak Gypsum Board is installed like traditional gypsum board offering a more reliable and less complicated solution than alternative methods requiring clips and/or channels.

SoundBreak Gypsum Board can be cut by scoring deeply from both sides of the board before snapping, or with the use of a hand or reciprocating saw.

TECHNICAL DATA

SURFACE BURNING CHARACTERISTICS

ASTM E 84
Flame spread: 15
Smoke developed: 0

WEIGHT

SoundBreak - 2.7 lbs/SF

FIRE RESISTANCE RATINGS

As an option, SoundBreak Gypsum Board may be used as an additional layer on one or both sides of fire-rated wall assemblies (i.e., U300, W300, U400, W400 and V400 series designs). SoundBreak Gypsum Board cannot be used as a substitute for 5/8" Type X gypsum board in a fire-related assembly.

SoundBreak Gypsum Board shall be attached in accordance with manufacturer's recommendations. When SoundBreak Gypsum Board is installed between the framing and the UL/ULC Classified gypsum board, the UL/ULC Classified gypsum board layer(s) required for the design is/are to be installed as indicated in the design as to fastener type and spacing, except that the required fastener length shall be increased by a minimum of 5/8" (16 mm).

For U300, W300, U400, W400 and V400 series designs, outer layer treated with joint compound and paper tape as specified in the design.

For additional information go to *UL/ULC Online Certifications Directories, Product Category Code CLB.V.R25426 – Wall and Partition Facings and Accessories.*

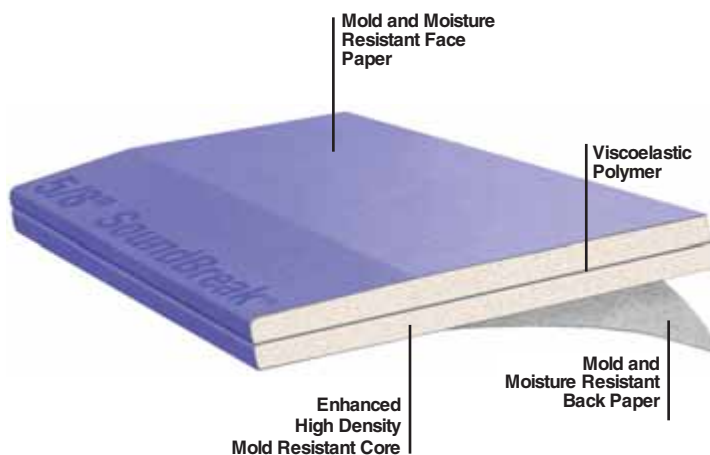

For additional information go to www.SoundBreak.info.

**MOLD AND MILDEW RESISTANCE

SoundBreak Gypsum Board was designed to provide extra protection against mold and mildew compared to standard gypsum board products.

When tested by an independent lab per ASTM D3273 ("Standard Test Method for Resistance to Growth of Mold on the Surface of Interior Coatings in an Environmental Chamber"), SoundBreak Gypsum Board achieved a score of 10, the best possible score for this test.

RECOMMENDATIONS

- Installation of SoundBreak Gypsum Board should be consistent with methods described in the standards and references noted.
- Stagger SoundBreak Gypsum Board joints from one side of the wall to another.
- Allow a 1/4" gap along all perimeter edges and completely seal 1/4" gap with acoustical sealant or caulk.
- Refrain from wall penetrations when possible.
- Limit necessary wall penetrations to one per stud cavity.
- Seal all penetrations with acoustical sealant and/or putty pads.
- The use of SoundBreak Gypsum Board in actual installations may not produce the same results as were achieved in controlled, laboratory conditions.
- Use an acoustical sealant that is applied per ASTM C919, such as Grabber Acoustical Sealant GSC, STI SpecSeal Smoke N Sound Caulk, BOSS 824 Acoustical Sound Sealant or equivalent.
- Use a putty pad that has been tested per ASTM E90, such as STI SpecSeal SSP Putty Pads or BOSS 818 Fire-Rated Putty Pads or equivalent.
- Exposure to excessive or continuous moisture and extreme temperatures should be avoided. SoundBreak Gypsum Board is not recommended where it will be exposed to temperatures exceeding 125° (52°C) for extended periods of time.
- SoundBreak Gypsum Board is for use in wall assemblies.
- Installing SoundBreak Gypsum Board panels over an insulating blanket, installed continuously across the face of the framing members, is not recommended. Blankets should be recessed and flanges attached to the sides of the studs.

SoundBreak Gypsum Board must be stored off the ground and under cover. Sufficient risers must be used to ensure support for the entire length of the gypsum board to prevent sagging.

SoundBreak Gypsum Board must be kept dry to minimize the potential for mold growth. Adequate care should be taken while transporting, storing, applying and maintaining SoundBreak Gypsum Board. For additional information, refer to the Gypsum Association publication, "Guidelines for the Prevention of Mold Growth on Gypsum Board" (GA-238-03), which is available at www.gypsum.org under the "Download Free Gypsum Association Publications" section.

DECORATION

For best painting results, all surfaces, including joint compound, should be clean, dust-free and not glossy. To improve fastener and joint concealment, a coat of quality drywall primer is recommended to equalize the porosities between surface paper and joint compound.

The selection of a paint to give the specified or desired finished characteristics is the responsibility of the architect or contractor.

SoundBreak Gypsum Board that is to have a wall covering applied should be prepared and primed as described for painting.

Gypsum Association GA-214, *Recommended Specification for Levels of Gypsum Board Finish*, should be referred to in order to determine the level of finishing required to ensure a properly prepared surface that accepts the desired decoration.

SPECIFICATIONS

PART 2 PRODUCTS

THE FOLLOWING PARAGRAPHS ARE FOR INSERTION INTO SECTIONS OF GENERIC SPECIFICATIONS OR GENERIC/PROPRIETARY SPECIFICATIONS COVERING GYPSUM BOARD PRODUCTS. THE NATIONAL GYPSUM PRODUCT NAME FOLLOWS THE GENERIC DESCRIPTION IN PARENTHESES.

2.01 MATERIALS

- A. Acoustically Enhanced Mold and Mildew Resistant Gypsum Board: A gypsum core wall panel with a constrained viscoelastic polymer center layer; surfaced with moisture/mold/mildew resistant paper on front, back and long edges and complying with ASTM C 1396 (Gold Bond® BRAND SoundBreak Gypsum Board)

1. Thickness: 5/8"
2. Width: 4'
3. Length: 8', 9', 10' or 12'
4. Edges: Tapered
5. Mold and Mildew Resistance: Panel Score of 10 when tested in Accordance with ASTM D 3273

PART 3 EXECUTION

3.01 INSTALLATION

- A. General: In accordance with the manufacturer's recommendations, National Gypsum Company "Gypsum Construction Guide."

Gridstone® BRAND Ceiling Panels

DESCRIPTION

Gridstone® BRAND prefinished ceiling panels have a non-combustible, Fire-Shield G gypsum core. The 2-mil white, stipple-textured vinyl laminate combines high light reflectance with easy cleanability.

Gridstone panels can be used for interior and exterior ceiling applications.

Gridstone Ceiling Panels install easily in standard 2' x 2' and 2' x 4' exposed grid systems. Ceiling panels have a rigid gypsum core which provides extra resistance to sagging and warping.

A noncombustible gypsum core ensures fire safety with 1 1/2- and 2-hour fire rating achievable depending on installation.

The sturdy white vinyl laminate eliminates additional finishing.

As little as 1" of material can be cut from Gridstone panels with practically none of the crumbling common with mineral fiber panels.

For exterior application, protect grid panels from direct exposure to weather, water and continuous high humidity. Under no circumstances should water be in contact with the back of the panels.

Overlaid insulation may cause excessive panel deflection and is not recommended where high humidity is likely to occur.

Extreme lighting conditions may distort texture appearance.

The use of strong organic solvents (such as ketones), harsh abrasive cleansers or steel wool are not recommended. These materials may cause dulling, discoloration, softening and other permanent damage to the vinyl surface.

USDA Acceptance: Gridstone panels are accepted by the USDA for use in food service and food processing areas.

TECHNICAL DATA

A. Specification Compliance

Gridstone panels conform to ASTM C 1396 Type X Class I.

B. Light Reflectance

LRI (75% or greater)

C. Sound Attenuation

(Per ASTM E1414)

Type	Thickness	Construction	CAC	NGC Report #
Gridstone	1/2" FSW-G (12.7 mm)	Continuous	46dB	6098001

D. Abrasion

Wet: (Gardner Scrub Tester) 2000 oscillations with no film break-through and only minor erosions.

Dry: (Taber Abrasion Test with CS-17 Wheel) 500 cycles with no break-through to the substrate.

E. Surface Burning Characteristics

(Per ASTM E 84)

Type	Flame Spread	Smoke Developed	Class	Test
Gridstone	5	0	A	WHI 694-0700.7

F. Weight

1/2" FSW-G - 2.18 lbs/SF

G. Fire Rating

(Per ASTM E 119)

Type	Thickness	Nominal Size	Design*	Rating
Gridstone	1/2" FSW-G (12.7 mm)	2' x 2' (610 mm x 610 mm)	UL G222 FM FC-299	2 hr.
		2' x 4' (610 mm x 1219 mm)	UL G259 FM FC-300	1 1/2 hr.

*See Quick Selector, page 25, for fire rated assembly details.



RECOMMENDATIONS

Gridstone ceiling panels are designed to be mounted in standard 15/16" exposed tee grid systems or environmental type grids for severe conditions, with grids either 2' x 2' or 2' x 4'. Grid installation should be conducted according to manufacturer's specification.

Each panel must be supported on all four (4) edges.

Cross ventilation must be provided in unheated or enclosed space above ceiling panels.

General: Install panels in lay-in suspension systems with edges concealed by flanges of suspension members. Cut boards to fit tightly at borders and penetrations so that cut edges are concealed by trim pieces and escutcheons.

Cleaning: Common dirt and stains on the vinyl surface can be removed with mild soap or detergent in lukewarm water. Use a light, scrubbing action with a cloth, sponge or soft brush.

If the suitability of any cleaning agent is unknown, check its effect on the Gridstone panel surface in a hidden area or on a scrap piece before attempting to remove a field stain.

Gridstone Ceiling Panels are not recommended for use in areas exposed to extreme or continuous moisture such as found in saunas, steam rooms, gang shower rooms or indoor pool enclosures, per ASTM C840 17.3.1.1.

DECORATION

Gridstone Brand Ceiling Panels are factory-finished decorative products which do not require painting. However, if desired, Gridstone can be painted with the following two products:

1. Two coats of an alkyd or latex enamel.
2. Oil primer with finish coat of oil or latex paint.
3. Two coats of latex paint.

Vinyl laminate on face of 2' x 2' Gridstone panel is directional. Install with all factory edges parallel (same direction).



GRIDSTONE® BRAND CleanRoom Ceiling Panels

DESCRIPTION

Gridstone BRAND CleanRoom Ceiling Panels are sealed on the face, back and long edges with a 2 mil rigid vinyl film. The exposed edges are factory sealed with a durable coating providing a completely sealed panel.

Gridstone CleanRoom panels are for use in systems designed for areas requiring high levels of air cleanliness for airborne particulate levels such as clean rooms and clean zones.

Designed for clean room use. Approved for use in systems, Class 100,000, Class 10,000, Class 1,000, Class 100 per Federal Standard 209E "Airborne Particulate Cleanliness Classes in Clean Rooms and Clean Zones."

Fire-resistant. A non-combustible gypsum core ensures fire safety with 1 1/2 and 2-hour fire rating achievable depending on installation.

Sag-resistant. Gridstone CleanRoom panels' rigid gypsum core prevents sagging and warping problems and is backed by a 15-year limited warranty.

Do not install panels in areas exposed to continuous high humidity such as saunas, steam rooms, gang showers, and indoor pools per ASTM C840, 17.3.1.1.

Overlaid insulation may cause excessive panels deflection and is not recommended where high humidity is likely to occur.

Extreme lighting conditions may distort texture appearance.

The use of strong organic solvents (such as ketones), harsh abrasive cleansers or steel wool are not recommended.

These materials may cause dulling, discoloration, softening and other permanent damage to the vinyl surface.

Gridstone CleanRoom panels are USDA accepted for use in food service and food processing areas.

TECHNICAL DATA

Reference Gridstone technical data on page 86.

RECOMMENDATIONS

Gridstone CleanRoom Ceiling Panels are designed to be used in a gasket seal suspended grid system using hold down clips.

Recommended use of Gordon DS-20 gasket Seal System or equivalent gasket sealed grid systems designed for clean room applications. Grid installation should be conducted according to manufacturer's specification.

Each panel must be supported on all four (4) edges.

Cross ventilation must be provided in unheated or enclosed space above ceiling panels.

General: Install panels in lay-in suspension systems with edges concealed by flanges of suspension members. Cut panels to fit tightly at borders and penetrations so that cut edges are concealed by trim pieces and escutcheons.

If panel cuts are required, exposed core should be sealed to maintain performance of the system.

Cleaning: Common dirt and stains on the vinyl surface can be removed with mild soap or detergent in lukewarm water. Use a light scrubbing action with a cloth, sponge or soft brush.

If the suitability of any cleaning agent is unknown, check its effect on the Gridstone CleanRoom panel surface in a hidden area or on a scrap piece before attempting to remove a field stain.

Vinyl laminate on face of 2' x 2' Gridstone CleanRoom panel is directional. Install with all factory edges parallel (same direction).

PACKAGING

2' x 2' – 4 pcs./bundle, 16 sq. ft., 80 bundles/Unit
Catalog Code – GB5040
2' x 4' – 4 pcs./bundle, 32 sq. ft., 40 bundles/Unit
Catalog Code – GB5030

All bundles are double-wrapped with long corner protectors.

SPECIFICATIONS

THE FOLLOWING PARAGRAPHS ARE FOR INSERTION INTO SECTIONS OF GENERIC SPECIFICATIONS OR GENERIC/PROPRIETARY SPECIFICATIONS COVERING GYPSUM BOARD PRODUCTS. THE NATIONAL GYPSUM PRODUCTS NAME FOLLOWS THE GENERIC DESCRIPTION IN PARENTHESES.

PART 2

2.02 MATERIALS

A. Fire-Resistant Sealed Vinyl Laminated Gypsum Grid Board: A gypsum core lay-in ceiling panel with additives to enhance sag and fire resistance of the core. Panels are sealed on face, back and long edges with a 2-mil rigid vinyl film and exposed edges are factory sealed with a durable coating providing a completely sealed panel; and complying with ASTM C 1396, type X; Class 1; E 1264, type XX, Patterns E, G.

Federal Standard 209E "Airborne Particulate Cleanliness Classes in Clean Rooms and Clean Zones." (Gridstone BRAND CleanRoom Ceiling Panels).

1. Thickness: 1/2"

2. Width and length:
2' x 2'
2' x 4'

PART 3

3.03 INSTALLATION

A. Install panels in lay-in suspension systems with edges concealed by flanges of suspension members. Cut panels to fit tightly at borders and penetrations so that cut edges are concealed by trim pieces and escutcheons.

PACKAGING

2' x 2' – 4 pcs./bundle, 16 sq. ft., 80 bundles/Unit
Catalog Code – GB5044
2' x 4' – 4 pcs./bundle, 32 sq. ft., 40 bundles/Unit
Catalog Code – GB5045

All bundles are double-wrapped with long corner protectors.

SPECIFICATIONS

THE FOLLOWING PARAGRAPHS ARE FOR INSERTION INTO SECTIONS OF GENERIC SPECIFICATIONS OR GENERIC/PROPRIETARY SPECIFICATIONS COVERING GYPSUM BOARD PRODUCTS. THE NATIONAL GYPSUM PRODUCT NAME FOLLOWS THE GENERIC DESCRIPTION IN PARENTHESES.

PART 2

2.02 MATERIALS

A. Fire Resistant Vinyl Laminated Gypsum Grid Board: A gypsum core lay-in ceiling board with additives to enhance sag and fire resistance of the core; surfaced with paper on the front and back and finished on the front with a 2 mil, white, stipple textured vinyl laminate; and complying with ASTM C 1396, type X; Class 1; E 1264, type XX, patterns E, G. (Gridstone Brand Ceiling Panel).

1. Thickness: 1/2"
2. Width and Length:
2' x 2'
2' x 4'

PART 3

3.03 INSTALLATION

A. Install boards in lay-in suspension systems with edges concealed by flanges of suspension members. Cut panels to fit tightly at borders and penetrations so that cut edges are concealed by trim pieces and escutcheons.

Gridstone® BRAND Hi-Strength Ceiling Panels

DESCRIPTION

Gridstone® BRAND Hi-Strength prefinished ceiling panels have a non-combustible high strength gypsum core formulated with increased uniformity and integrity which increases its sag resistance.

Gridstone Hi-Strength panels can be used for interior and exterior ceiling applications in protected, well-ventilated spaces that receive intermittent exposure to moisture.

Lightweight. Gridstone Hi-Strength 5/16" panels are 40% lighter in weight than standard gypsum ceiling panels.

Quick, dry installation. Gridstone Hi-Strength Ceiling panels score and snap clean and install easily in standard exposed grid systems.

Pre-decorated. The sturdy white vinyl laminate eliminates additional finishing.

Do not install panels in areas exposed to continuous high humidity such as saunas, steam rooms, gang showers, and indoor pools per ASTM C840, 17.3.1.1.

For exterior application, protect grid panels from direct exposure to weather, water and continuous high humidity. Under no circumstances should water be in contact with the back of the panels.

Overlaid insulation may cause excessive panel deflection and is not recommended. These materials may cause dulling, discoloration, softening and other permanent damage to the vinyl surface.

Gridstone Hi-Strength panels are not listed in fire-rated assemblies.

USDA Acceptance: Gridstone Hi-Strength panels are accepted by the USDA for use in food service and food processing areas.

TECHNICAL DATA

SURFACE BURNING CHARACTERISTICS

ASTM E 84
Flame Spread: 5
Smoke Developed: 0

WEIGHT

5/16" Hi-Strength - 1.24 lbs/SF

SOUND ATTENUATION

ASTM E 1414 Test Method
Ceiling Attenuation Class
(CAC)-41 dB

LIGHT REFLECTANCE

LR 1 (75% or greater)

RECOMMENDATIONS

Gridstone Hi-Strength ceiling panels are designed to be mounted in standard 15/16" exposed tee grid systems or environmental type grids for severe conditions, with grids either 2' x 2' or 2' x 4'. Grid installation should be conducted according to manufacturer's specification.

Each panel must be supported on all four (4) edges.

Cross ventilation must be provided in unheated or enclosed space above ceiling panels.

General: Install panels in lay-in suspension systems with edges concealed by flanges of suspension members. Cut panels to fit tightly at borders and penetrations so that cut edges are concealed by trim pieces and escutcheons.

Cleaning: Common dirt and stains on the vinyl surface can be removed with mild soap or detergent in lukewarm water. Use a light scrubbing action with a cloth, sponge or soft brush.

If the suitability of any cleaning agent is unknown, check its effect on the Gridstone Hi-Strength panel surface in a hidden area before attempting to remove a field stain.

NOTE: Vinyl laminate on face of 2' x 2' Gridstone Hi-Strength panel is directional. Install with all factory edges parallel (same direction).

DECORATION

Gridstone Hi-Strength Ceiling panels are factory-finished decorative products which do not require painting. However, if desired, Gridstone can be painted with the following products:

1. Two coats of alkyd or latex enamel.
2. Oil primer with finish coat of oil or latex paint.
3. Two coats of latex paint.

PACKAGING

2' x 2' – 6 pcs./bundle, 24 sq. ft., 80 bundles/Unit
Catalog Code – GB5020
2' x 4' – 6 pcs./bundle, 48 sq. ft., 40 bundles/Unit
Catalog Code – GB5010

All bundles are double-wrapped with long corner protectors.

SPECIFICATIONS

THE FOLLOWING PARAGRAPHS ARE FOR INSERTION INTO SECTIONS OF GENERIC SPECIFICATIONS OR GENERIC/PROPRIETARY SPECIFICATIONS COVERING GYPSUM BOARD PRODUCTS. THE NATIONAL GYPSUM PRODUCT NAME FOLLOWS THE GENERIC DESCRIPTION IN PARENTHESES.

PART 2

2.02 MATERIALS

A. Vinyl laminated Gypsum Grid board: A gypsum core lay-in ceiling panel with additives to enhance sag resistance of the core; surfaced with paper on the front and back and finished on the front with a 2 mil, white, stipple textured vinyl laminate; and complying with ASTM C 1396, Class 1, E 1264 Type XX, Patterns E, G (Gridstone BRAND Hi-Strength Ceiling Panels)

1. Thickness: 5/16"
2. Width and length:
2' x 2'
2' x 4'

PART 3

3.03 INSTALLATION

A. Install panels in lay-in suspension systems with edges concealed by flanges of suspension members. Cut panels to fit tightly at borders and penetrations so that cut edges are concealed by trim pieces and escutcheons.

DESCRIPTION

Gold Bond® Foil Back Gypsum Board consist of a fire-resistant gypsum core encased in heavy natural-finish paper on the face side and strong liner paper on the backside to which aluminum foil is laminated. The ends are square cut and finished smooth.

BASIC USES

Foil Back Gypsum Board can be used for exterior walls and ceilings in new construction and remodeling. The aluminum foil, laminated to the back surface, is a vapor retarder to keep interior moisture within the building at a suitable comfort level. For use with furred masonry, wood or steel framing, Gold Bond Foil Back Gypsum Board is effective for single-layer applications and as a base layer in double-layer applications where a vapor retarder of 1.0 perm or less is required.

ADVANTAGES

1. In tests conducted according to ASTM Test Procedure E 96 (desiccant method), 1/2" Foil Back Gypsum Board showed a performance of 0.06 perm compared to 34 perm for 1/2" regular gypsum board and 28 perm for 1/2" gypsum board with two coats of flat latex paint.
2. In-place cost of Foil Back Gypsum Board installation is lower per thousand sq. ft. than a similar installation for regular gypsum board and polyethylene-film retarder installed separately.
3. Easy-to-handle Foil Back Gypsum Board is adaptable to virtually all exterior wall and ceiling construction: wood frame, furred masonry.

LIMITATIONS

1. Not recommended for use where exposure to moisture and high outside temperature is extreme and continuous. Under these conditions, a qualified mechanical engineer should determine location of the vapor retarder.
2. Not to be used as a base for ceramic or other tile or as a base layer for prefinished vinyl wall boards in double-layer assemblies. Also, not to be used as a base for adhesively applied vinyl or other highly water-vapor-resistant wall coverings.
3. To prevent objectionable sag in ceilings, weight of overlaid unsupported insulation should not exceed: 1.3 lb./sq. ft. for 1/2" thick boards with frame spacing 24" o.c.; 2.2 lb./sq. ft. for boards with frame spacing 16" o.c. Boards 3/8" thick must not be overlaid with unsupported insulation. Unheated attic spaces should be properly ventilated.
4. Foil Back Gypsum Board is not recommended for use in hot, humid, climates such as the Southern Atlantic and Gulf Coast areas.

MATERIALS

Manufactured boards with gypsum core, paper-encased with aluminum foil laminated backing.

SIZES AND TYPES

Thickness	Width	Length
1/2"	4'	6' to 16'
5/8"	4'	6' to 16'

Edges: Square, tapered or Sta-Smooth.

APPLICABLE STANDARDS

ASTM C 1396

TECHNICAL DATA

SURFACE BURNING CHARACTERISTICS

(ASTM E 84)

Flame spread: 15

Smoke developed: 0

WEIGHT

1/2" Regular - 1.6 lbs/SF

5/8" Type X - 2.2 lbs/SF

FIRE RESISTANCE RATINGS

Foil Back Gypsum Board has not been used in fire resistance tests. Fire resistance ratings represent the results of tests on assemblies made up of specific materials in a specific configuration. When selecting construction designs to meet certain fire resistance requirements, caution must be used to ensure that each component of the assembly is the one specified in the test. Further, precaution should be taken that assembly procedures are in accordance with that of the tested assembly. (For copies of specific tests, call 1-800-NATIONAL or 1-800-628-4662.)

RECOMMENDATIONS

Examine and inspect materials to which gypsum board is to be applied. Remedy all defects prior to installation of gypsum board. Any defects in the finished installation due to misaligned framing or other cause will be the responsibility of the work performed under that section of the specification and such defects shall be remedied under that section of the specification

Gypsum board should be applied first to ceiling at right angles to framing members, then to walls.

Boards of maximum practical length should be used so that an absolute minimum number of end joints occur. Board edges should be brought into contact with each other but should not be forced into place.

Gypsum board joints at openings should be located so that no end joint will align with edges of openings unless control joints will be installed at these points. End joints should be staggered, and joints on opposite sides of a partition should not occur on the same stud.

Gypsum board should be held in firm contact with the framing member while fasteners are being driven. Fastening should proceed from center portion of the gypsum board toward the edges and ends. Fasteners should be set with the heads slightly below the surface of the gypsum board in a dimple formed by the hammer or power screwdriver. Care should be taken to avoid breaking the face paper of the gypsum board. Improperly driven nails or screws shall be removed.

For best painting results, all interior surfaces, including joint compound, should be clean, dust-free and not glossy. To improve fastener and joint concealment, a prime coat of drywall primer is recommended to equalize the porosities between surface paper and joint compound.

See page 63, *Environmental Conditions and Limitations*.

GYPSUM SYSTEMS

Nonload-Bearing Steel Frame Partitions

DESCRIPTION

Steel framed drywall partitions are comprised of steel floor and ceiling tracks, steel studs and Gold Bond Gypsum Board which is attached with self-drilling drywall screws. Metal products are to meet or exceed all applicable ASTM standards.

Gypsum board may be applied horizontally or vertically in single or double layers. In double layer construction, the face, or finish layer, may be Durasan panels adhesively applied to the base layer. For specific fire and sound ratings for this system, see test data on pages 11 through 26.

ADVANTAGES

1. Openings provided throughout the length of the steel studs permit the easy horizontal routing of water, gas and electrical conduit. These openings may also be used to install C.R. Channel stiffeners where increased rigidity is required. Interruption of the floor or ceiling track allows the vertical installation of larger utilities.
2. Fire resistance: 1-, 2-, 3- and 4-hour fire ratings have been assigned to these systems (see pages 11-26).
3. Sound resistance: where a superior Sound Transmission Class is required, it can be achieved through the use of several variations with this system.

TECHNICAL DATA

PARTITION HEIGHTS

Light Gauge Steel Studs are designed to frame nonload-bearing partitions which are limited in height by deflection resulting from extraneous horizontal forces. For any given horizontal load, the amount of deflection increases as the height of the partition increases.

Tables 1 and 2 on the next page show maximum partition heights based on specific design criteria. The height limits shown are based on the gypsum board

and the steel studs acting as a composite section to provide a maximum deflection of $L/120$, $L/240$, $L/360$

(L = partition height in inches) with a horizontal load of 5 psf, 7.5 psf, and 10 psf of partition surface.

Increased rigidity may be obtained by placing stiffener channels through the steel stud cut-outs, by using two layer application of gypsum board or by decreasing stud spacing.

Standard 25 and 20 gauge studs, recommended for interior partitions, have height limits as shown in Tables 1 and 2. Gypsum board must be attached to full height on both sides of studs with Type S Bugle Head Drywall Screws (Type S-12 for 20 gauge studs) spaced not more than 12" o.c. on all studs when framing is 24" o.c. and 16" o.c. if framing is 16" o.c. or less. Screw lengths must be not less than $3/8$ " greater than the total thickness of the gypsum board being fastened.

Light steel 20 gauge studs are designed for exterior, nonload-bearing curtain wall systems, but are also used for interior partitions to provide more rigidity or greater heights than can be obtained with Standard 25 gauge studs.

LIMITATIONS

1. Maximum stud spacing for single layer application of $1/2$ " and $5/8$ " gypsum board is 24" o.c. If $3/8$ " gypsum board is used, it must be applied in two layers, with the second layer adhesively applied; 24" o.c. stud spacing may be used.
2. Where long, continuous runs of this wall system are employed, control joints must be provided every 30' or less.
3. Where structural movement may impose direct loads on these systems, isolation details are required.
4. Partitions should not be used where frequently exposed to excessive moisture unless all surfaces

are waterproofed.

5. To prevent weakening due to calcining, gypsum board should not be exposed to temperatures over 125°F for extended periods of time.
6. Gypsum board joints on single layer, or the face layer on two layer applications, shall not occur within 12" of the corners of door frames unless control joints are installed at the corners.
7. For limitations regarding selection of doors and doorframes, refer to table on page 92.
8. Where reference is made to nominal gauges, 25 gauge relates to a minimum base steel of .0179", and 20 gauge to .0329".

Table 1

25 GAUGE STUDS/PARTITION LIMITING HEIGHTS					
Stud Depth	Stud Spacing	Deflection Limit	Lateral Pressure		
			5 psf (240 Pa)	7.5 psf (360 Pa)	10 psf (480 Pa)
1-5/8 in. (41.3mm)	12 in. (305mm)	L/120 L/240 L/360	11-2 (3400) 8-10 (2690)	9-9 (2970)	8-10 (2690)
	16 in. (406mm)	L/120 L/240 L/360	10-7 (3230) 8-4 (2540)	8-10 (2690)	8-4 (2540)
	24 in. (610mm)	L/120 L/240 L/360	9-9 (2970) 7-11 (2410)	8-0 (2440)	
2-1/2 in. (63.5mm)	12 in. (305mm)	L/120 L/240 L/360	15-1 (4600) 11-11 (3630) 10-5 (3180)	12-4 (3760) 10-5 (3180) 9-1 (2770)	10-9 (3280) 9-6 (2900)
	16 in. (406mm)	L/120 L/240 L/360	13-3 (4040) 11-3 (3430) 9-10 (3000)	10-10 (3300) 9-10 (3000) 8-7 (2620)	9-5 (2570) 8-11 (2720)
	24 in. (610mm)	L/120 L/240 L/360	11-10 (3610) 10-7 (3230) 9-3 (2820)	9-8 (2950) 9-3 (2820) 8-1 (2460)	8-5 (2570) 8-5 (2570)
3-1/2 in. (88.9mm)	12 in. (305mm)	L/120 L/240 L/360	17-8 (5380) 15-4 (4670) 13-3 (4040)	14-3 (4340) 13-3 (4040) 11-7 (3530)	12-5 (3780) 12-0 (3660) 10-5 (3180)
	* 16 in. (406mm)	L/120 L/240 L/360	15-4 (4670) 14-4 (4370) 12-4 (3760)	12-5 (3780) 12-5 (3780) 10-10 (3300)	10-9 (3280) 10-9 (3280) 9-9 (2970)
	24 in. (610mm)	L/120 L/240 L/360	13-9 (4190) 13-5 (4090) 11-7 (3530)	11-0 (3350) 11-0 (3350) 10-1 (3070)	9-5 (2870) 9-5 (2870) 9-1 (2770)
4 in. (101.6mm)	12 in. (305mm)	L/120 L/240 L/360	19-6 (5940) 16-5 (5000) 14-4 (4370)	15-9 (4800) 14-4 (4370) 12-6 (3810)	13-8 (4170) 13-0 (3960) 11-4 (3450)
	16 in. (406mm)	L/120 L/240 L/360	17-2 (5230) 15-4 (4670) 13-4 (4060)	13-10 (4220) 13-4 (4060) 11-8 (3560)	11-11 (3630) 11-11 (3630) 10-6 (3200)
	24 in. (610mm)	L/120 L/240 L/360	15-1 (4600) 14-2 (4320) 12-4 (3760)	12-1 (3680) 12-1 (3680) 10-9 (3280)	10-5 (3180) 10-5 (3180) 9-9 (2970)
6 in. (152.4mm)	12 in. (305mm)	L/120 L/240 L/360	22-10 (6960) 22-1 (6730) 19-4 (5890)	18-7 (5660) 18-7 (5660) 16-9 (5110)	16-2 (4930) 16-2 (4930) 15-0 (4570)
	16 in. (406mm)	L/120 L/240 L/360	19-9 (6020) 19-9 (6020) 17-11 (5460)	16-2 (4930) 16-2 (4930) 15-7 (4750)	14-0 (4270) 14-0 (4270) 3-10 (4220)
	24 in. (610mm)	L/120 L/240 L/360	16-9 (5110) 16-9 (5110) 16-9 (5110)	13-5 (4090) 13-5 (4090) 13-5 (4090)	11-5 (3480) 11-5 (3480) 11-5 (3480)

Note: Limiting height tables adapted with permission from ASTM C 754. Copyright ASTM.
Tables based on tests conducted with gypsum board attached with screws
12" o.c. to framing.

*Applicable for 3/5/8" stud depth.

Table 2

20 GAUGE STUDS/PARTITION LIMITING HEIGHTS					
Stud Depth	Stud Spacing	Deflection Limit	Lateral Pressure		
			5 psf (240 Pa)	7.5 psf (360 Pa)	10 psf (480 Pa)
1-5/8 in. (41.3mm)	12 in. (305mm)	L/120 L/240 L/360	13-0 (3960) 10-4 (3150) 9-0 (2740)	11-4 (3450) 9-0 (2740)	10-4 (3150)
	16 in. (406mm)	L/120 L/240 L/360	12-1 (3680) 9-8 (2950) 8-5 (2570)	10-7 (3230) 8-5 (2570)	9-8 (2950)
	24 in. (610mm)	L/120 L/240 L/360	11-0 (3350) 8-9 (2670) 7-8 (2340)	9-7 (2920) 7-8 (2340)	8-9 (2670)
2-1/2 in. (63.5mm)	12 in. (305mm)	L/120 L/240 L/360	17-9 (5410) 13-11 (4240) 12-1 (3680)	15-6 (4720) 12-1 (3680) 10-6 (3200)	13-11 (4240) 10-11 (3300) 9-5 (2870)
	16 in. (406mm)	L/120 L/240 L/360	16-5 (5000) 12-10 (3910) 11-2 (3400)	14-4 (4370) 11-2 (3400) 9-8 (2950)	12-10 (3910) 10-0 (3050) 8-8 (2640)
	24 in. (610mm)	L/120 L/240 L/360	14-10 (4520) 11-7 (3530) 10-0 (3050)	13-0 (3960) 10-0 (3050) 8-7 (2620)	11-7 (3530) 8-11 (2720) 7-8 (2340)
3-1/2 in. (88.9mm)	12 in. (305mm)	L/120 L/240 L/360	22-6 (6860) 17-10 (5440) 15-6 (4720)	19-8 (5990) 15-6 (4720) 13-7 (4140)	17-10 (5440) 14-1 (4290) 12-4 (3760)
	* 16 in. (406mm)	L/120 L/240 L/360	20-8 (6300) 16-5 (5000) 14-3 (4340)	18-1 (5510) 14-3 (4340) 12-6 (3810)	16-5 (5000) 12-11 (3940) 11-4 (3450)
	24 in. (610mm)	L/120 L/240 L/360	18-6 (5640) 14-9 (4500) 12-9 (3890)	16-2 (5840) 12-9 (3890) 11-2 (3400)	14-9 (4500) 11-7 (3530) 10-1 (3070)
4 in. (101.6mm)	12 in. (305mm)	L/120 L/240 L/360	25-1 (7650) 19-11 (6070) 17-4 (5280)	21-11 (6680) 17-4 (5280) 15-0 (4570)	19-11 (6070) 15-8 (4780) 13-7 (4140)
	16 in. (406mm)	L/120 L/240 L/360	23-1 (7040) 18-4 (5590) 15-11 (4850)	20-2 (6150) 15-11 (4850) 13-9 (4190)	18-4 (5590) 14-5 (4390) 12-6 (3810)
	24 in. (610mm)	L/120 L/240 L/360	20-9 (6320) 16-5 (5000) 14-3 (4340)	18-1 (5510) 14-3 (4340) 12-4 (3760)	16-5 (5000) 12-10 (3910) 11-2 (3400)
6 in. (152.4mm)	12 in. (305mm)	L/120 L/240 L/360	33-9 (10290) 26-9 (8150) 23-5 (7140)	29-6 (8990) 23-5 (7140) 20-6 (6250)	26-9 (8150) 21-3 (6480) 18-7 (5660)
	16 in. (406mm)	L/120 L/240 L/360	30-10 (9400) 24-6 (7470) 21-4 (6500)	27-0 (8230) 21-4 (6500) 18-9 (5720)	24-6 (7470) 19-5 (5920) 17-0 (5180)
	24 in. (610mm)	L/120 L/240 L/360	27-2 (8280) 21-7 (6580) 18-10 (5740)	23-10 (7260) 18-10 (5740) 16-7 (5050)	19-1 (5820) 17-3 (5260) 15-0 (4570)

09 29 00

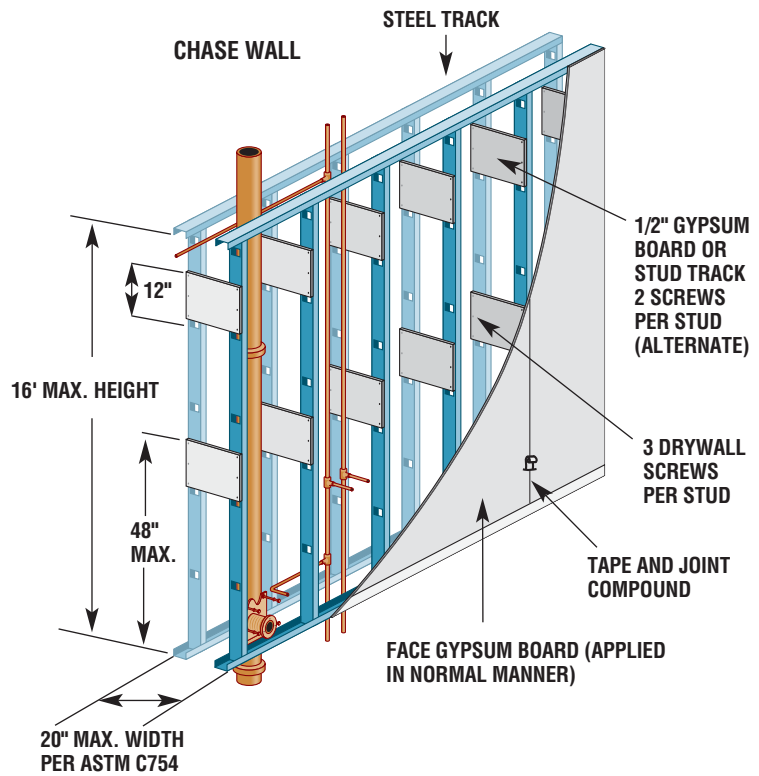
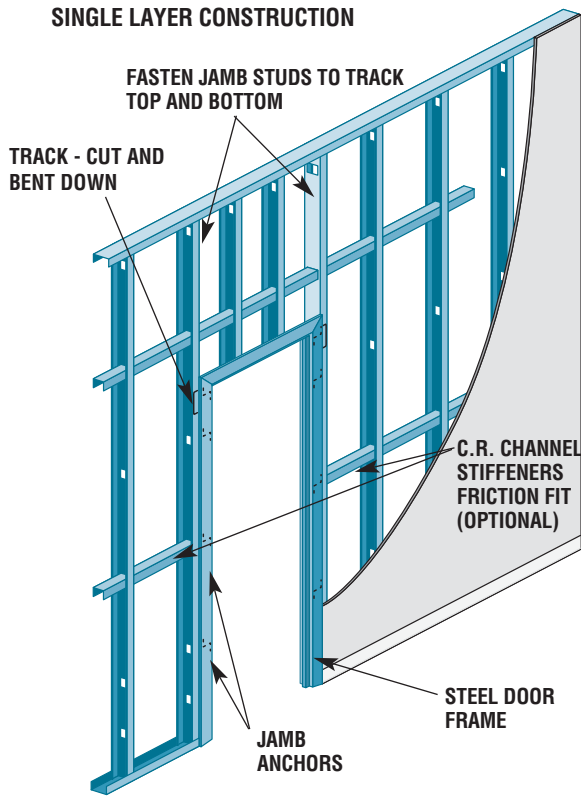

FRAMING REQUIREMENTS AT DOORS

Door Weight	Jamb Steel Studs Min. Base Steel, In.	(Type of Door Frame)			(Special Details) Bracing Over Headers	Requires Mechanical Closure	Partition Height Limits* Stud Size				
		Knock Down Alum.	Knock Down Steel	Fixed Steel			1 5/8" (41.3mm)	2 1/2" (63.5mm)	3 5/8" (92.1mm)	4" (102mm)	6" (152mm)
Up to 50 lbs. (23 kg)	0.0179	X	X	X		NA**	10'(3048mm)	14'(4267mm)	15'(4572mm)	14'(4267mm)	
	0.0179	X	X	X	X	10'(3048mm)	12'(3657mm)	16'(4876mm)	17'(5181mm)	16'(4876mm)	
	0.0329	X	X	X	X	—	16'(4876mm)	21'(6400mm)	22'(6705mm)	22'(6705mm)	
50 lbs. (23 kg) to 80 lbs. (36 kg)	0.0179		X	X	X	—	10'(3048mm)	14'(4267mm)	15'(4572mm)	14'(4267mm)	
	0.0179	X			X	X	10'(3048mm)	12'(3657mm)	14'(4267mm)	15'(4572mm)	
	0.0179			X	X	X	12'(3657mm)	14'(4267mm)	16'(4876mm)	17'(5181mm)	
	0.0329			X			10'(3048mm)	14'(4267mm)	15'(4572mm)	15'(4572mm)	
	0.0329		X	X	X	X	12'(3657mm)	16'(4876mm)	17'(5181mm)	17'(5181mm)	
80 lbs. (36 kg) to 120 lbs. (54 kg)	0.0329 dbl. web to web			X			16'(4876mm)	21'(6400mm)	22'(6705mm)	22'(6705mm)	
	0.0329 dbl. web to web	X			X		16'(4876mm)	21'(6400mm)	22'(6705mm)	22'(6705mm)	
80 lbs. (36 kg) to 120 lbs. (54 kg)	0.0179			X	X	X	12'(3657mm)	14'(4267mm)	15'(4572mm)	14'(4267mm)	
	0.0329	X	X		X	X	12'(3657mm)	16'(4876mm)	17'(5181mm)	17'(5181mm)	
	0.0329 dbl. web to web			X	X		16'(4876mm)	21'(6400mm)	22'(6705mm)	22'(6705mm)	

* For a specific partition having a door opening compare above partition height limits with height tables on page 88. The lower height table governs.

** NA – Not Allowed.



25 & 20 GAUGE STUDS

"C" shaped metal studs fabricated from galvanized steel. 20 gauge studs are for curtainwall construction or more rigid partitions.

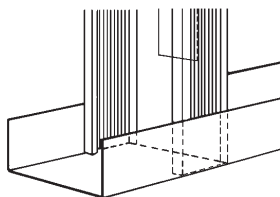

FURRING CHANNEL

Used as cross furring members for attachment of gypsum board or lath on ceiling or furred masonry walls.

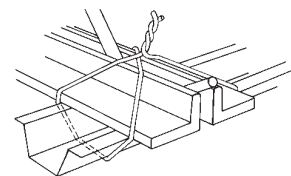

25 & 20 GAUGE TRACK

Fastened at floor and ceiling to support the steel studs. Track is channel-shaped and fabricated from galvanized steel.

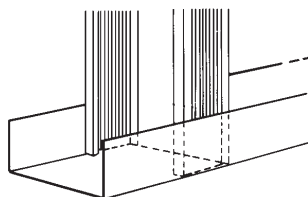

RESILIENT FURRING CHANNEL

Used as cross furring members for attachment of gypsum board and improves sound isolation on ceilings and partitions.

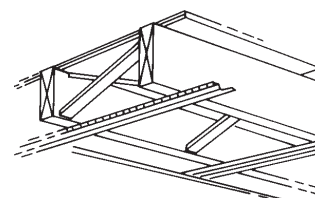

Z FURRING CHANNEL

Generally used on the inside of exterior masonry walls to support rigid foam insulation and to provide a fastening surface for gypsum board.

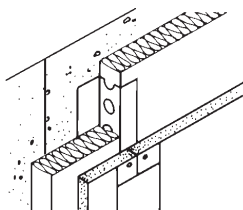

FLOOR & CEILING RUNNER 2" x 2" 20 GAUGE

Used as a utility floor and ceiling runner. Also used in vertical shaftwall inside corner application.

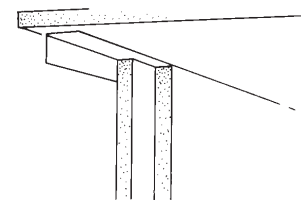

COLD ROLLED CHANNEL

Used in suspended ceilings and as stiffeners in stud partitions.

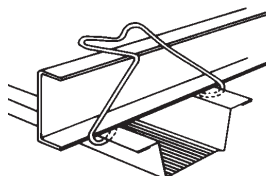

L RUNNER

Perforated – Ceiling or floor support for 2" solid lath and plaster partition.

Plain – Ceiling support for 2" solid gypsum board partition using 1" shaftliner.

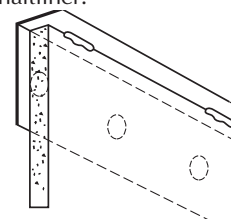

*Metal products are not manufactured by National Gypsum Company

09 29 00

Accessories*

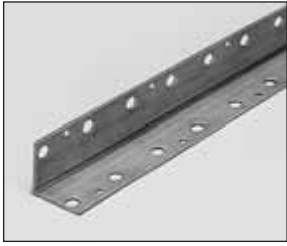

GYPSUM BOARD CORNERBEAD

Used to reinforce exterior gypsum board corners. For use with all gypsum board thicknesses, single or double layer application.

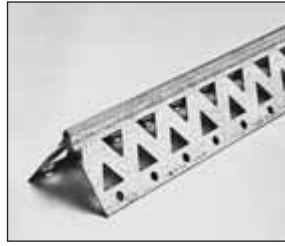
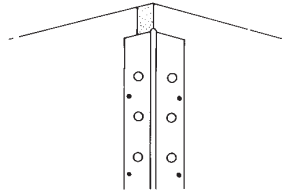

ARCH CORNERBEAD

Can be used straight for exterior corners or flanges, or may be snipped and bent to form arches.

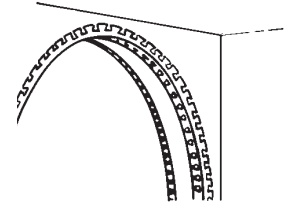

J GYPSUM BOARD CASING

Provides a finished edge at door and window jambs by slipping over edge. Is face nailed and exposed surface finished with joint treatment.

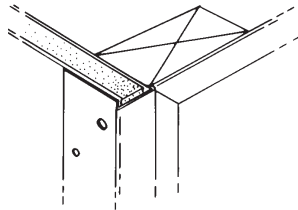

E-Z STRIP® EXPANSION JOINT

Designed for drywall or veneer plaster systems. A vinyl extrusion used as an expansion or control joint for ceilings or partitions.

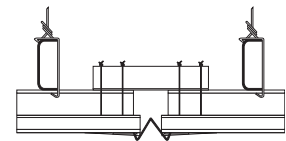

J GYPSUM BOARD CASING

(Reveal Trim)
Used at door, window, inside corners when facing must be isolated from abutting elements. Requires no joint treatment finish.

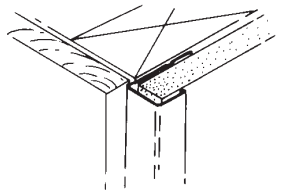

.093 ZINC CONTROL JOINT

Designed as an expansion or control joint for ceiling and partition areas for both drywall or veneer plaster systems.

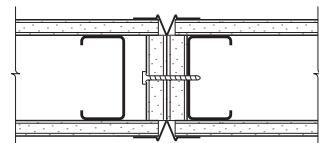

L GYPSUM BOARD CASING

Used as a finished edge at door and window jambs. Is face nailed and exposed surface finished with joint treatment.

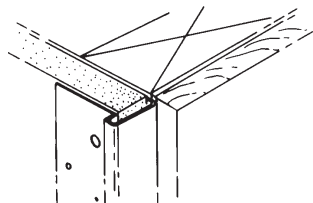

*Accessories are not manufactured by National Gypsum Company

DETAILS

STUD SPLICE

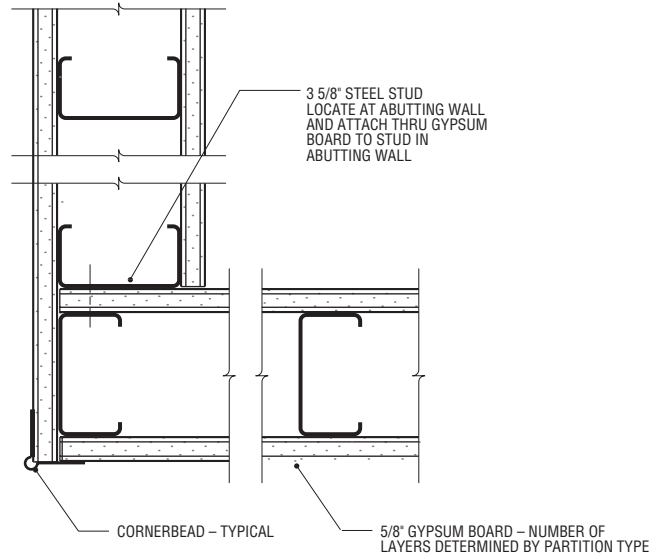
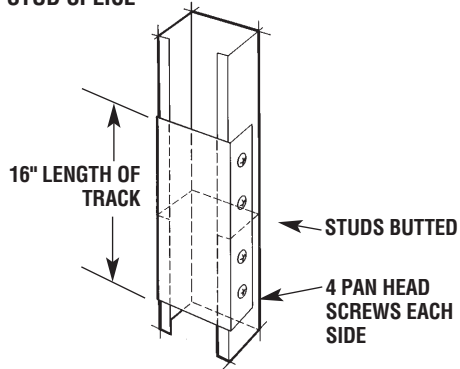

CORNER DETAIL

09250E
Scale 3" = 1'-0"

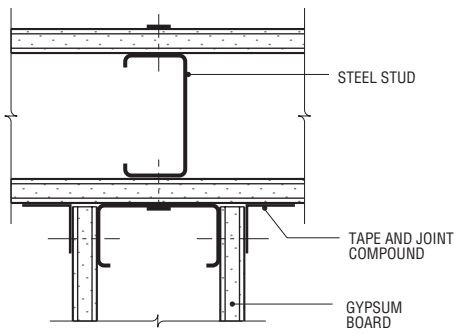

PARTITION INTERSECTION

09250F
Scale: 3" = 1'-0"

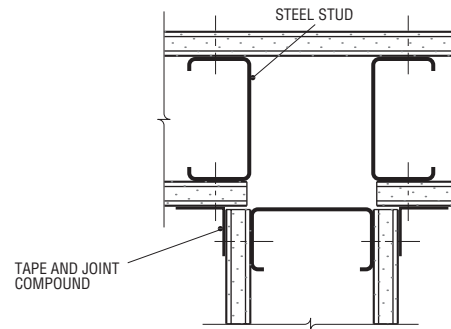

ALTERNATE PARTITION INTERSECTION

09250G
Scale: 3" = 1'-0"

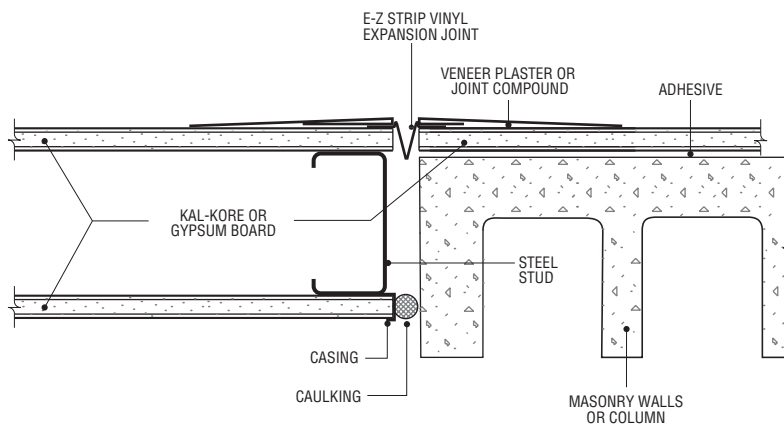

JOINT WHERE WALL FRAMING CHANGES

09250CC
Scale: 3" = 1'-0"

09 29 00

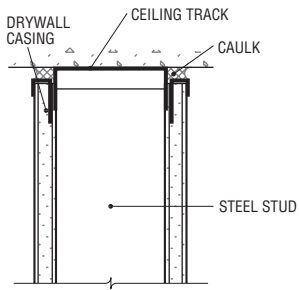

ATTACHMENT TO CONCRETE SLAB

09250H
Scale: 3" = 1'-0"

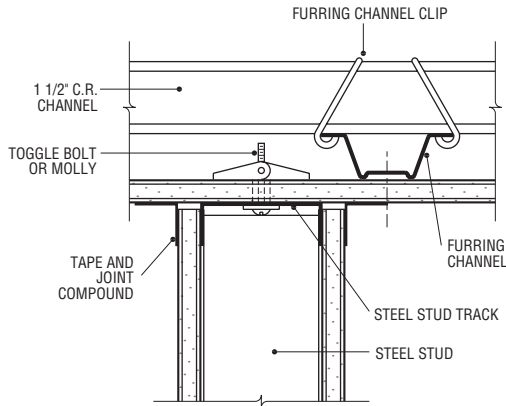

ATTACHMENT TO SUSPENDED CEILING

09250I
Scale: 3" = 1'-0"

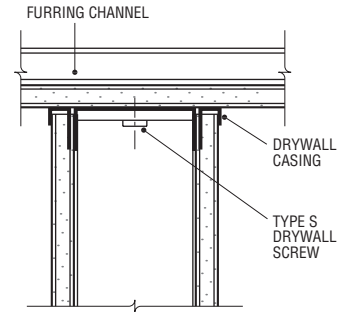

ATTACHMENT TO FURRED CEILING

09250J
Scale: 3" = 1'-0"

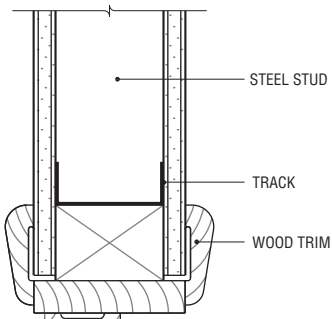

DOOR HEAD DETAIL - WOOD

09250K
Scale: 3" = 1'-0"

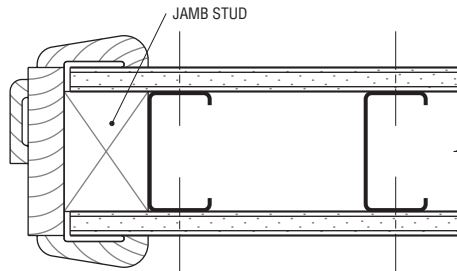

DOOR JAMB DETAIL - WOOD

09250N
Scale: 3" = 1'-0"

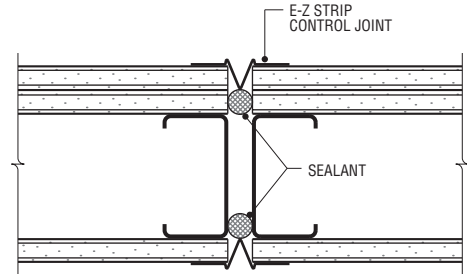

WALL CONTROL JOINT

09250M
Scale: 3" = 1'-0"

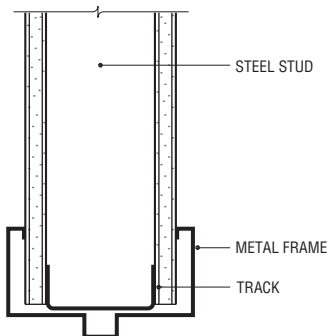

DOOR HEAD DETAIL - METAL

09250L
Scale: 3" = 1'-0"

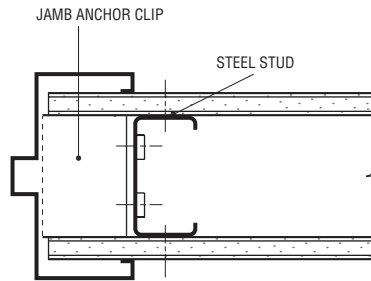

DOOR JAMB DETAIL - METAL

09250O
Scale: 3" = 1'-0"

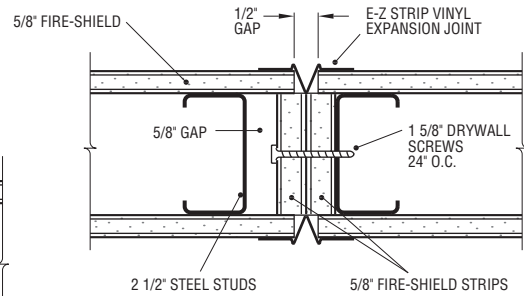

ONE HOUR FIRE RATED CONTROL JOINT DETAIL
Based on Warnock Hersey Report No. WHI-651-0318.1
and Factory Mutual Design No. W 1B-1 hr.

09250P
Scale: 3" = 1'-0"

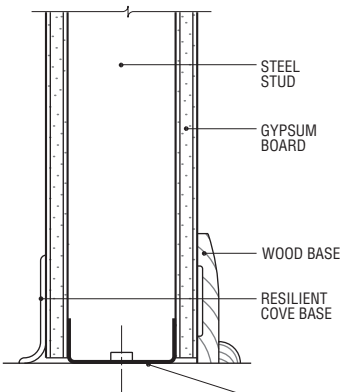

BASE DETAIL

09250Q
Scale: 3" = 1'-0"

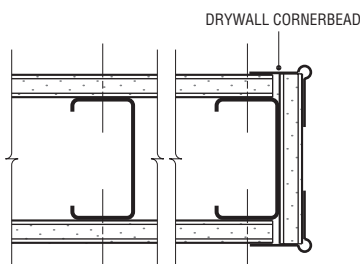

PARTITION END DETAIL

09250R
Scale: 3" = 1'-0"

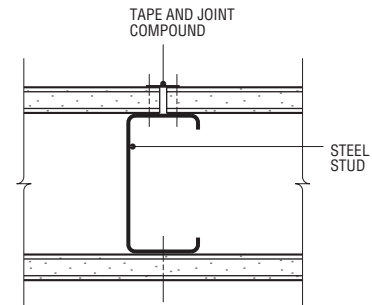

BUTT JOINT DETAIL

09250S
Scale: 3" = 1'-0"

RECOMMENDATIONS

1. FRAMING

Align floor and ceiling tracks to ensure plumb partition. Secure track with suitable fasteners at a maximum of 24" o.c. Position studs in track on 16" or 24" centers by rotating into place for a friction fit. Steel studs shall be installed with all flanges pointed in the same direction. Secure studs located adjacent to door and window frames, partition intersections and corners with 3/8" Pan Head Type S Screws driven through both flanges of studs and tracks or by using a stud clincher.

2. SINGLE LAYER OR FIRST PLY

Cut gypsum board to allow for a 1/8" to 1/4" gap between gypsum board and floor to prevent potential wicking.

Apply gypsum board with the length parallel or at right angles to the studs. Center abutting ends or edges over the stud flanges.

For metal framing, screws shall be Type S, of a length to provide not less than 3/8" penetration into framing and shall be spaced 24" o.c. max. If no adhesive is used, standard fastener spacings shall prevail.

For non-fire-rated construction, locate all attaching screws 12" o.c. when framing is 24" o.c. and 16" o.c. when framing is 16" o.c. or less. For fire-rated construction, vertical application, space screws 12" o.c. in the field and 8" o.c. along the vertical abutting edges unless otherwise specified. Attach the gypsum board to Steel Studs with Type S Drywall Screws using an electric, drywall screwdriver with a #2 Phillips bit. For vertical gypsum board application with studs 24" o.c., erect the gypsum board on one side of the partition, screw attaching to open end of stud flange first at vertical gypsum board joints. Complete the gypsum board application to the entire side of the partition in this manner. For the opposite side, cut the first gypsum board 2' wide so that joints will be staggered. Fasten this and succeeding gypsum boards to all studs on this side. When partition face is complete, return to the first side and complete screw attachment of gypsum board to all intermediate studs.

Make door and window framing openings of such size that when the gypsum board is secured to the studs, it will fit snugly into the steel frames.

3. FACE LAYER

Mechanical attachment of face layer for fire or sound rated constructions shall be made in accordance with the specifications for the system selected. When the face ply is attached with mechanical fasteners and with no adhesive between plies, the maximum spacing and minimum penetration recommended for screws should be the same as for single ply application.

SPECIFICATIONS

THE FOLLOWING PARAGRAPHS ARE FOR INSERTION INTO SECTIONS OF GENERIC SPECIFICATIONS COVERING METAL FRAMING PRODUCTS.

VERIFY DESCRIPTIONS OF METAL FRAMING PRODUCTS WITH MANUFACTURER.

PART 2 PRODUCTS

2.02 MATERIALS

A. METAL FRAMING

1. Studs: 1 5/8", 1 1/2", 3 5/8", 4" and 6" C shaped studs, weighing 312 lbs., 370 lbs., 448 lbs., 472 lbs., and 607 lbs. per 1000 lin. ft. with min. base steel of 0.0179", galvanized, and complying with ASTM C 645.
2. Track: 1 5/8", 2 1/2", 3 5/8", 4" and 6" U shaped track with 1" legs, weighing 244 lbs., 303 lbs., 378 lbs., 404 lbs. and 539 lbs. per 1000 lin. ft. with min. base metal of 0.0179", galvanized and complying with ASTM C 645.
3. 1 5/8", 2 1/2", 3 5/8", 4" and 6" U shaped track with 1 1/4" legs, weighing 278 lbs., 337 lbs., 412 lbs., 438 lbs. and 572 lbs. per 1000 lin. ft. with min. base metal of 0.0179", galvanized and complying with ASTM C 645.
4. Studs: 2 1/2", 3 5/8", 4" and 6" C shaped studs. Studs weighing 679 lbs., 817 lbs., 867 lbs. and 1105 lbs. per 1000 lin. ft. with min. base metal of 0.0329", galvanized and complying with ASTM C 645.
5. Track: 2 1/2", 3 5/8", 4" and 6" U shaped track with 1.177" legs, weighing 604 lbs., 740 lbs., 785 lbs. and 1027 lbs. per 1000 lin. ft. with min. base metal of 0.0329", galvanized and complying with ASTM C 645.
6. Z Furring Channels: 1", 1 1/2" and 2" Z shaped channels, weighing 201 lbs., 236 lbs. and 268 lbs. per 1000 lin. ft. with min. base steel of 0.0179", galvanized and complying with ASTM C 645.
7. Floor & Ceiling Runner: L shaped runner weighing 545 lbs. per 1000 lin. ft. with min. base steel of 0.0329", galvanized.

PART 3 EXECUTION

3.01 INSTALLATION

- A. General: In accordance with ASTM C 754, the manufacturer's recommendations and National Gypsum Company "Gypsum Construction Guide."

INSTALLATION

SHELF BRACKET

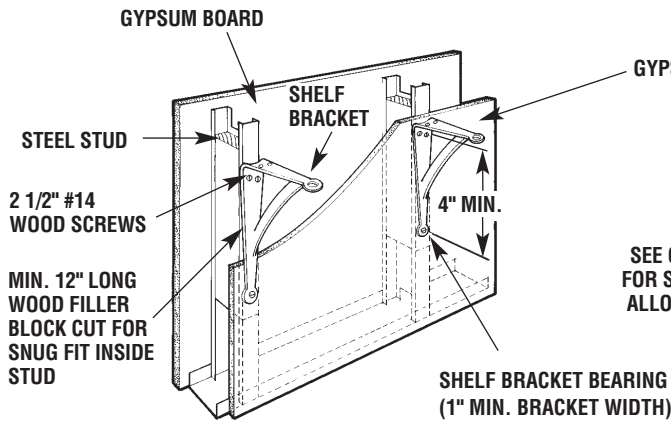

SHELF BRACKET BETWEEN STUDS

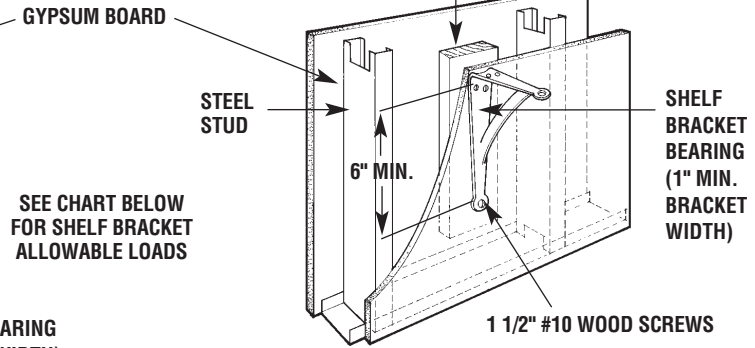

SHELF BRACKET BETWEEN STUDS

Allowable Load With Wood Blocks

Wood Block with 1/2" (12.7 mm) gypsum board	40 ft. lbs. per bracket (54 N-M)
Wood Block with 5/8" (15.9 mm) gypsum board	70 ft. lbs. per bracket (95 N-M)

Allowable Load With Sheet Metal (.0239)

.0239 sheet metal substituted for wood with 1/2" (12.7 mm) gypsum board	40 ft. lbs. per bracket (54 N-M)
.0239 sheet metal substituted for wood with 5/8" (15.9 mm) gypsum board	50 ft. lbs. per bracket (68 N-M)

SHELF BRACKET

Allowable Load

Wood Block	80 ft. lbs. per bracket (108 N-M) – 2' o.c. (610 mm)
	40 ft. lbs. per bracket (54 N-M) – 4' o.c. (1219 mm)
Without filler blocks using min. #10 sheet metal screws into screw stud	50 ft. lbs. per bracket (68 N-M) – 2' o.c. (610 mm)
	25 ft. lbs. per bracket (34 N-M) – 4' o.c. (1219 mm)

EXTRA HEAVY LOADS

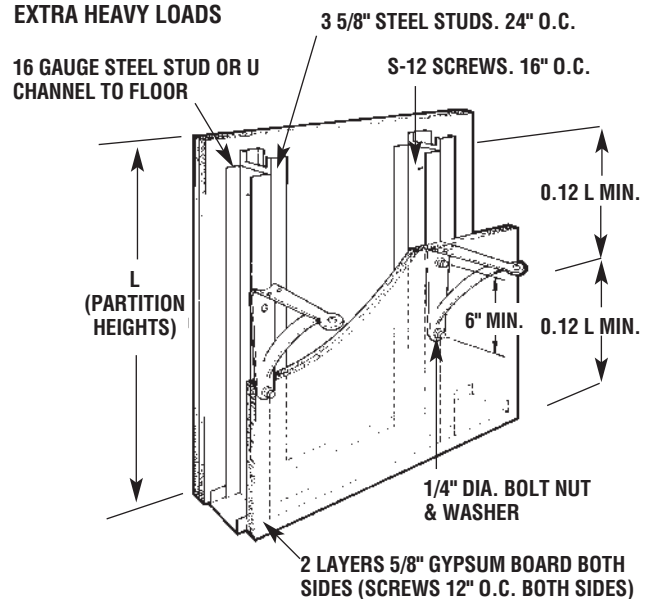

FLUSH-TO-WALL ATTACHMENTS

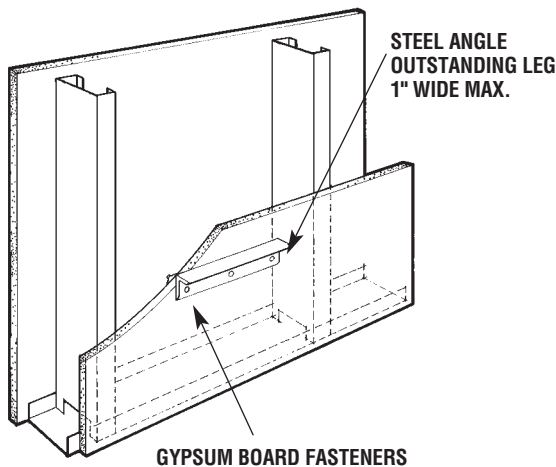

GYPSUM BOARD FASTENERS

Type Fastener	Size	Allowable Load	
		1/2" (12.7 mm) Gypsum Board	5/8" (15.9 mm) Gypsum Board
Hollow	1/8" (3.2 mm) dia. SHORT	50 lbs.(23 kg)	—
Wall	3/16" (4.8 mm) dia. SHORT	65 lbs.(29 kg)	—
Screw	1/4" (6.4 mm), 5/16" (7.9 mm)	65 lbs.(29 kg)	—
Anchors	3/8" (9.4 mm) dia. SHORT	—	90 lbs.(41 kg)
	3/16" (4.8 mm) dia. LONG	—	95 lbs.(43 kg)
	1/4" (6.4 mm), 5/16" (7.9 mm), 3/8" (9.4 mm) dia. LONG	—	—
Common	1/8" (3.2 mm) dia.	30 lbs.(14 kg)	90 lbs.(41 kg)
Toggle	3/16" (4.76 mm) dia.	60 lbs.(27 kg)	120 lbs.(54 kg)
Bolts	1/4" (6.4 mm), 5/16" (7.9 mm), 3/8" (9.4 mm) dia.	80 lbs.(36 kg)	120 lbs.(54 kg)

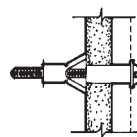

HOLLOW WALL SCREW ANCHOR

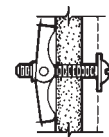

COMMON TOGGLE BOLT

DESCRIPTION

There are three types of steel furring members for the screw attachment of gypsum board ceilings.

1. Furring Channels
2. Resilient Furring Channels
3. Steel Studs

All three are suitable for fastening to the lower chord of steel joists or to carrying channels in suspended ceiling constructions. Furring Channels are secured with clips or tie wires. Resilient Furring Channels shall be secured with wire ties. Steel Studs shall be attached with tie wires as shown on page 99. Gold Bond Gypsum Board shall be applied using gypsum drywall screws spaced not greater than 12" o.c.

RECOMMENDATIONS

These furring systems, when employed with normal steel joist construction and gypsum board, constitute non-combustible construction and, in addition, fire resistance ratings are achieved as indicated on page 25.

LIMITATIONS

Lighting and other fixtures shall be supported by framing; do not use gypsum board to support them.

For large expanses of these ceiling systems with perimeter relief, control joints must be located a maximum of 50' o.c. in either direction; without perimeter relief, 30' o.c. maximum in either direction.

RECOMMENDATIONS

DIRECT ATTACHMENT

1. Space and position furring channels in accordance with manufacturer recommendation. Wire tie Resilient Furring Channels, Steel Studs or Furring Channels as shown on page 100.
2. Apply gypsum board with its long dimension at right angles to the channels. Locate gypsum board butt joints over the center of the furring channels. Attach gypsum board with 1" self-drilling drywall screws 12" o.c. located not less than 3/8" nor more than 1/2" from edges.

SUSPENDED

1. Install 1 1/2" channels 4' o.c. with No. 8 ga. hanger wire spaced a maximum of 4' o.c. along carrying channels. Attach Furring Channels spaced not more than 24" o.c. perpendicular to 1 1/2" C.R. Channels with double strand of saddle tied No. 16 ga. galvanized tie wire, or 1 1/2" Furring Channel Clips.
2. Apply gypsum board with its long dimension at right angles to the Furring Channels. Locate gypsum board butt joints over the center of Furring Channels. Attach gypsum board with 1" self-drilling drywall screws 12" o.c. in the field of the board 8" or 12" o.c. at butt joints, located not less than 3/8" or more than 1/2" from edges.

DETAILS

SPLICE JOINT FOR STUDS

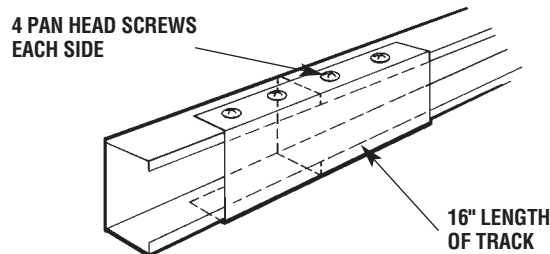

FURRING CHANNEL SPLICE JOINT

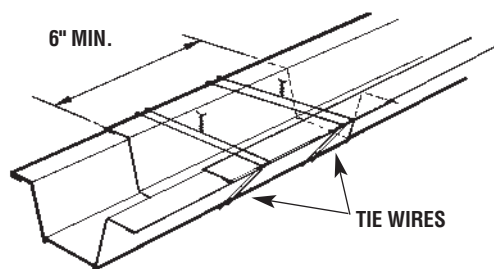

SPECIFICATIONS

See CSI Metal Framing Specifications on page 97.

09 29 00

INSTALLATION

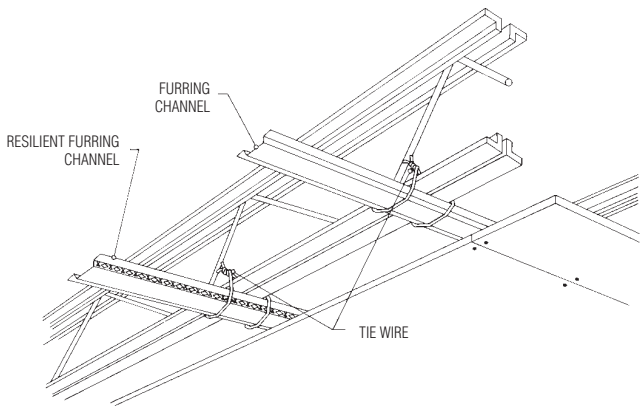

FURRING CHANNELS

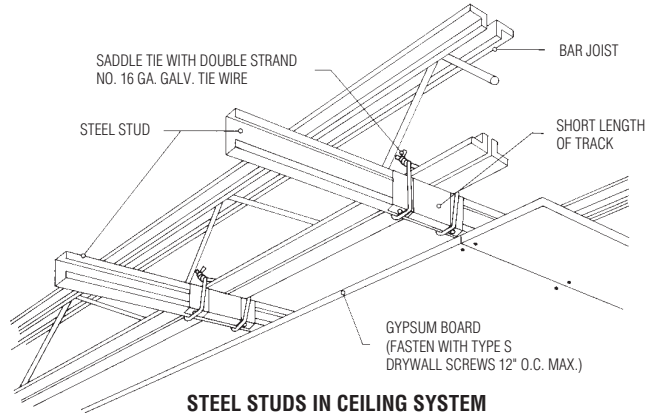

STEEL STUDS IN CEILING SYSTEM

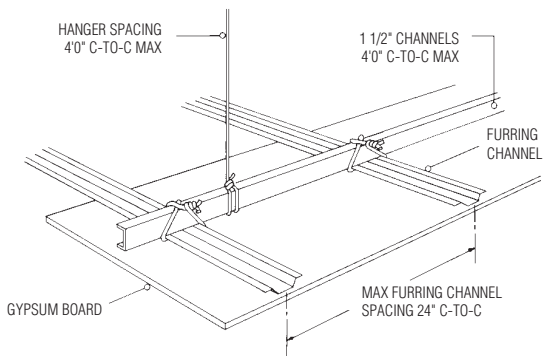

FURRING CHANNEL DETAILS

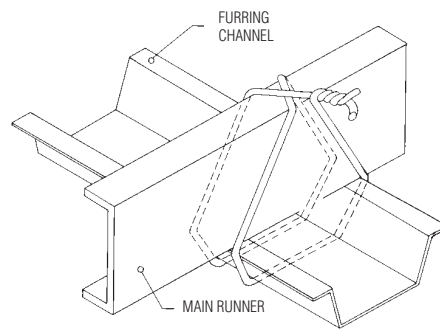

SADDLE TIE

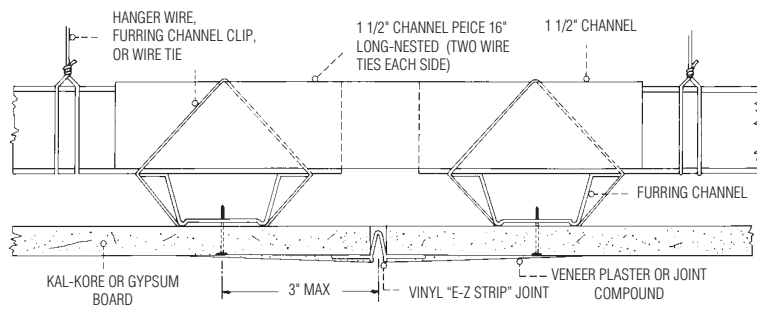

CONTROL JOINT PARALLEL TO FURRING CHANNELS

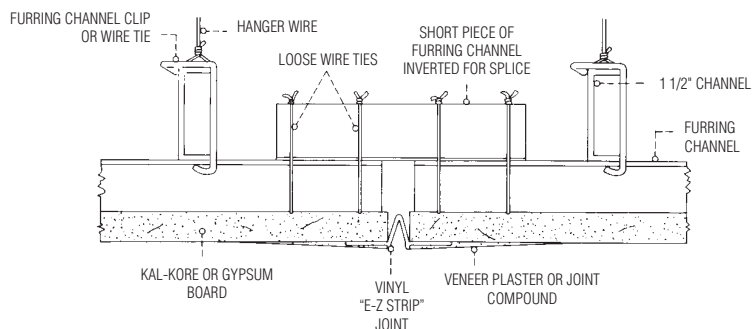

CONTROL JOINT PERPENDICULAR TO FURRING CHANNELS

DESCRIPTION



STANDARD APPLICATION

Standard application (single nailing) Regular Gold Bond Gypsum Board is usually applied directly to wood framing members. Ceilings are applied first, then sidewalls. Boards should be accurately cut and joints abutted but not forced together. Horizontal application, long edges at right angles to nailing members, is preferred for it minimizes joints and strengthens the wall or ceiling. Nails shall be spaced not to exceed 7" on ceilings, or 8" on sidewalls, a minimum of 3/8" and a maximum of 1/2" from edges and ends of gypsum board. Gypsum board nails or annular ring nails, such as the GWB-54 illustrated above, are recommended. For a description of the various types of Gold Bond Gypsum Boards, refer to pages 58 through 89.

DOUBLE NAILING

Double nailing is an alternate method of attachment devised to minimize nail-pops. This system requires doubling up on the field nails. The total quantity of nails used does not double, however, since maximum nail spacing is increased to 12" o.c. and conventional nailing is used on the perimeter. Application is accomplished by first single nailing the field of the board, starting at the center and working toward ends and edges. Another nail is then driven in close proximity (2" to 2 1/2") to each of the first nails. The first series of nails are then struck again to ensure the board is drawn tightly to the nailing member.

FLOATING ANGLE METHOD

Floating angle method of gypsum board application eliminates the use of the perimeter nails at interior corners and where ceilings and walls meet. This method reduces the stress and strain on the board if framing settles. Reference ASTM C 840, Section 9.

ADHESIVE NAIL-ON METHOD

Apply drywall adhesive to face of studs or joists in continuous beads. Reference ASTM C 840 Section 10.

FIRE RESISTANCE RATINGS

Where fire ratings are required, refer to pages 12, 13, 22, and 23. For complete construction details consult the specific test report.



SCREW APPLICATION

Screw application is often preferred as the screw holds the gypsum board tight against the framing when applied as recommended. Type W 1 1/4" Drywall Screws are driven with an electric screw gun equipped with adjustable screw depth control and a #2 Phillips bit. If framing is spaced up to 16" o.c., screws are spaced 12" o.c. max on ceilings and 16" o.c. max on walls. If framing is spaced 24" o.c., screw spacing must not exceed 12" o.c. Minimum screw penetration shall be 5/8" for wood studs.

RECOMMENDATIONS

Cut gypsum board to allow for a 1/8" to 1/4" gap between gypsum board and floor to prevent potential wicking.

1/2" or 5/8" gypsum board single layer application is recommended for interior finishing of all buildings with wood frame construction. The use of

5/8" gypsum board or 1/2" High Strength Ceiling Board on ceilings will minimize sagging. During cold weather the use of polyethylene film as a ceiling vapor retarder is not recommended unless ceiling insulation is installed *prior* to application of gypsum board.

LIMITATIONS

1. 1/4" Gold Bond Gypsum Board should be applied only to existing surfaces and should not be applied directly to framing members, except when used with other thicknesses in double layer systems tested for specific purposes. Existing walls and ceilings should be sound, flat, level and without void spaces. 1/4" thick gypsum board should be applied with a combination of mechanical fasteners, nails or screws, and adhesive that will bond to the substrate surface covering. Nails or screws should penetrate framing spaced not over 24" o.c. Adhesive should be applied between framing members to bond the gypsum board to the substrate.
2. 3/8" Gold Bond Gypsum Board should not be used on nailing members over 16" o.c. When applied to ceilings, the gypsum board must be applied with the paper bound edges at right angles to the nailing members and shall not be used to support insulation. 1/2" or 5/8" Gypsum Board should not be used on nailing members over 24" o.c. When applied to ceilings with the nailing members exceeding 16" o.c., the gypsum board must be applied with the paper bound edges at right angles to the nailing members.
3. If gypsum board ceiling boards are nailed to cross furring, these members shall have a minimum cross section of 2" x 2" (nominal) with same spacing limitations as above. With screws, nominal 1" x 2" furring may be used. Spacing of the framing members to receive furring must not exceed 24" o.c.
4. In single ply installation, all ends and edges of gypsum board should occur over framing members or other solid backing except where treated joints occur at right angles to framing or furring members.
5. Hold the gypsum board firmly against the framing while fastening with nails or screws. Start at the center and work toward each end and edge, spacing the fasteners as recommended for each type of application.
6. Lighting and other fixtures shall be supported by framing; do not use gypsum board to support them.
7. Gypsum board ceilings to be decorated with water-thinned spray texture shall be 1/2" or 5/8" thick and applied perpendicular to the framing. Framing shall not exceed 16" o.c. for 1/2" regular gypsum board and 24" o.c. for 1/2" High Strength Ceiling Board and 5/8" gypsum board.
8. Gypsum board ceilings to receive a spray texture finish must be primed with a sealing latex primer and allowed to dry before spraying. This is to minimize sagging of the gypsum board and discoloration problems. The use of water-based spray textures may cause unprimed gypsum board to sag when any one or more of the following conditions exist:
 1. Unventilated buildings.
 2. Use of vapor retarders under certain conditions.
 3. Periods of prolonged high humidity due to either weather conditions or closed building units (poor drying conditions).
 4. Inadequate framing support (can occur where framing changes direction).
 5. Improper type or thickness of gypsum board.

RECOMMENDATIONS

SINGLE LAYER GYPSUM BOARD APPLICATION (also Base Layer of Double Layer)

1. NAILS

Nails shall be GWB-54 or cooler type located 3/8" min. to 1/2" max. from edges and ends of board. Nails shall be a max. of 7" o.c. on ceilings and a max. of 8" o.c. on walls, except for "Double Nailing" Procedure.

2. SCREWS

Drywall screws for attaching gypsum board to wood framing shall be 1 1/4",

Type W spaced not to exceed 12" o.c. on ceilings, 16" o.c. on sidewalls where studs are 16" o.c. and 12" o.c. on sidewalls where studs are spaced 24" o.c. Screws for attaching gypsum board to gypsum board shall be Type G spaced as required.

3. STAPLES

Base layer gypsum board may be applied with power-driven staples spaced 7" o.c. on ceilings; 8" o.c. on sidewalls. Staples shall be U.S. Standard 16 gauge galvanized wire staples

with 7/16" wide crown with legs having divergent points. Legs shall be not less than 1" long for 3/8" base board, 1 1/8" long for 1/2" base board or 1 1/4" long for 5/8" base board.

4. CORNERBEADS

Cornerbead shall be nailed with gypsum board nails spaced no greater than 9" apart on each flange of the bead with the nails opposite. In lieu of nailing, cornerbead may be crimp applied 6" o.c. with a special tool.

5. ADHESIVE APPLICATION TO FRAMING

- A. Apply gypsum board adhesive to the wood framing with a caulking gun.

INSTALLATION

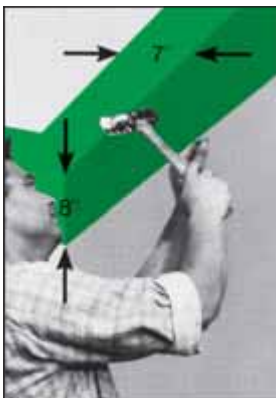

FLOATING ANGLES
No nails in shaded area.



SCREW APPLICATION
Fast, positive, fewer heads to treat.



DOUBLE NAILING
Minimizes nail-pop.



ADHESIVE/NAIL-ON
Ideal for prefinished boards.

FLOATING INTERIOR ANGLES

To minimize fastener popping in areas adjacent to wall and ceiling intersections, the floating angle method should be used for either single or double layer application of gypsum board to wood framing. This method is applicable where single nailing, double nailing or screw attachment is used. Gypsum board should be applied to ceiling first.

REPAIRING NAIL-POPS

Nail-pops are caused by lumber shrinkage after board application; loose gypsum board; improperly aligned, twisted or bowed framing; or improper nailing.

Pops appearing before/during decoration should be repaired immediately. Those which occur after one or more month's heating are usually caused by lumber shrinkage and should not be repaired until after heating season. To repair, re-nail about 1 1/2" from the popped nail along the framing while applying sufficient pressure adjacent to the nail to bring board in firm contact with the framing. If the popped nail

was improperly driven, remove it. If properly driven, reseal just below the board face. Remove any loose material over resealed nail before treating nail heads with joint compound and redecorating.

ADHESIVE NAIL-ON APPLICATION

The adhesive nail-on system for application of gypsum board to wood framing strengthens the wall and minimizes the possibility of nail-popping. It reduces the number of nails in the field, provides for intimate contact and a continuous bond between the gypsum board and wood framing. All surfaces that come in contact with the adhesive should be dry, free of dirt, grease, oil or other foreign materials.

SCREW APPLICATION

Drywall screws attach gypsum board to wood or steel framing or to other gypsum boards. They pull the board tightly to the supports, minimizing surface defects due to loose boards. When properly driven, they make a uniform depression free of ragged edges and fuzz.

TECHNICAL DATA

FASTENER SELECTOR FOR WOOD FRAMING

Nail Type	Length	Gypsum Board Type	Thickness
GWB-54 [Annular Ring 1/4" (6.4 mm) head, 098 Dia. shank]	1 1/4" (31.8 mm) 1 3/8" (34.9 mm)	Regular or Foil-back gypsum board.	3/8" (9.4 mm), 1/2" (12.7 mm)
Gypsum Board Nail (Coated cooler, flat head, diamond point)	Nail length should be sufficient for 7/8" (22.2 mm) penetration into the framing member.	Regular, Foil-back or Fire-Shield (type X) gypsum board.	1/4" (6.4), 3/8" (9.4 mm) 1/2" (12.7 mm), 5/8" (15.9 mm), 1" (25.4 mm)
Where a certain degree of fire resistance is required for gypsum board assemblies and construction, nails of same or larger length, shank diameter, and head bearing area as those described in the fire test report must be used.			
Screws Type W	1 1/4" (31.8 mm)	Regular or Foil-back.	3/8" (9.4 mm), 1/2" (12.7 mm), 5/8" (15.9 mm)
Staples US Std. 16 gauge 7/16" (11.1) crown with divergent points	1" long (25.4 mm) 1 1/8" (28.6 mm) 1 1/4" (31.8 mm)	Only in first layer of multi-layer application.	3/8" (9.4 mm) 1/2" (12.7 mm) 5/8" (15.9 mm)

Maximum Framing Spacing For Single-Layer Gypsum Board

Gypsum Board Thickness	Gypsum Board Orientation to Framing	Maximum Framing Spacing
Ceilings:		
3/8" (9.5 mm) ^A	Perpendicular ^B	16" (406 mm) o.c.
1/2" (12.7 mm)	Parallel ^B	16" (406 mm) o.c.
1/2" (12.7 mm)	Perpendicular ^B	24" (610 mm) o.c.
5/8" (15.9 mm)	Parallel	16" (406 mm) o.c.
5/8" (15.9 mm)	Perpendicular	24" (610 mm) o.c.
Walls:		
3/8" (9.5 mm)	Perpendicular or Parallel	16" (406 mm) o.c.
1/2" (12.7 mm)	Perpendicular or Parallel	24" (610 mm) o.c.
5/8" (15.9 mm)	Perpendicular or Parallel	24" (610 mm) o.c.

^A Shall not support thermal insulation

^B On ceilings to receive hand or spray-applied water-based texture material either 1/2" (12.7 mm) gypsum ceiling board (ASTM C 1396/C 1396M) shall be applied perpendicular to framing; other gypsum board products shall be applied perpendicular to framing and board thickness shall be increased from 3/8" (9.5 mm) to 1/2" (12.7 mm) for 16" (406 mm) o.c. framing and from 1/2" (12.7 mm) to 5/8" (15.9 mm) for 24" (610 mm) o.c. framing.

DETAILS

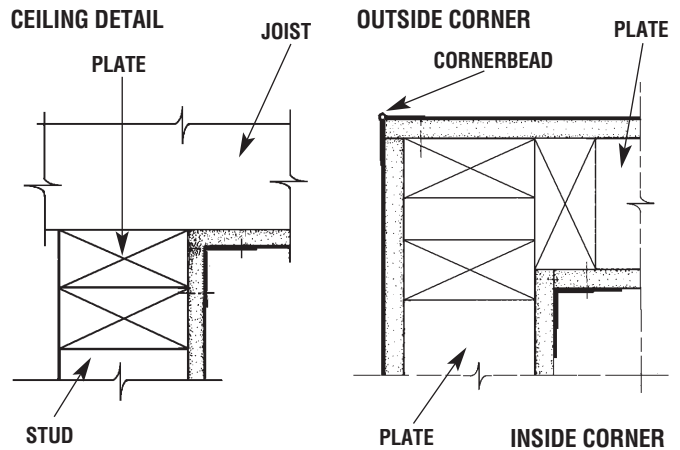

SPECIFICATIONS

See CSI 3-Part format Generic/Proprietary Specifications on page 120.

09 29 00

Wood Frame Walls and Ceilings/Double Layer Construction

DESCRIPTION

The Gold Bond double layer system consists of a face layer of gypsum board job-laminated to a base layer of gypsum board, or gypsum sound deadening board applied with power driven screws or staples, or nailed to the framing in the conventional manner.

DETAILS

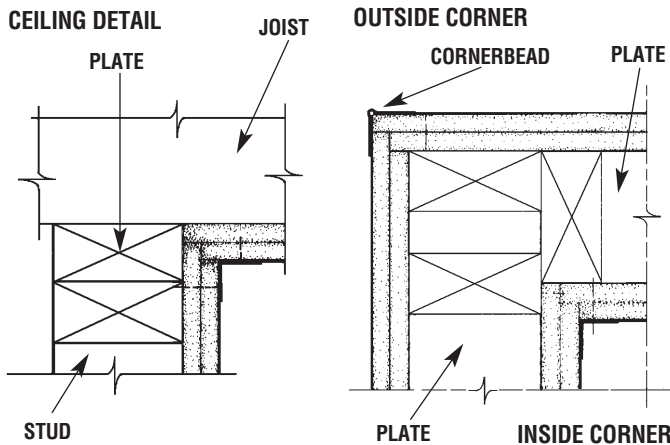

RECOMMENDATIONS

DOUBLE LAYER GYPSUM BOARD

1. Base layer

The first layer may be specified the same as single layer application except that fasteners shall be driven flush with the board surface and joints will not be treated. Base layer must not be secured to framing with clips.

2. Adhesive Application of Face Layer, General

- All joints shall fall at least 10" from parallel joints in the base layer. Adhesive shall be: (select one)
- ProForm all-purpose ready mix joint compound or Sta-Smooth setting type compound applied with a notched spreader to the back side of the finish layer.
- Adhesive is applied with a caulking gun. Align board edges. Reference ASTM C 840, section 9.

3. Adhesive Application, Regular Gypsum Board

The finish layer shall be positioned on the wall or ceiling within 10 minutes (unless otherwise specified above) and held in place with sufficient temporary (nails) (Type G Drywall Screws) (bracing) to ensure adequate contact and alignment of the gypsum boards. When the bond has developed (usually 24 hours) the temporary (fasteners) (bracing) shall be removed. Resulting holes shall be filled flush to the surface with Joint Compound and the joints shall be finished. Cornerbead shall be applied at all exterior angles.

4. Adhesive Application, Prefinished Gypsum Board

- Pre-bow board by storing overnight in such a position that the ends of each board curve away from the base layer when put in vertical mounting position.
- Apply ready-mix or Sta-Smooth joint compound in nominal 5" ribbons of four 1/4" x 1/4" beads located around the perimeter and center of the boards (approximate coverage for ready-mix is 9-10 gal./1000 sq.ft and Sta-Smooth is 50-60 lbs./1000 sq.ft.). An alternative is 2" diameter daubs 1/2" thick, 16" o.c. (approximate coverage for ready-mix is 5 1/2"-6 gal./1000 sq.ft. and Sta-Smooth is 30 - 35 lbs./1000 sq.ft.).
- Temporarily brace, as required, to ensure proper contact and edge alignment of boards.

5. Mechanical Application of Face Layer

Mechanical attachment of face layer for fire or sound rated constructions shall be made in accordance with the specifications for the system selected.

For non-rated construction, nails used in wood framing to supplement adhesive shall be type GWB, of a length to provide 7/8" minimum penetration into framing and shall be spaced 16" o.c. max. Screws used in wood framing shall be Type W, of a length to provide minimum 5/8" penetration into the framing and shall be spaced 24" o.c. max. If no adhesive is used, standard fastener spacings shall prevail.

INSTALLATION

Cut gypsum board to allow for a 1/8" to 1/4" gap between gypsum board and floor to prevent potential wicking.

In double layer construction use any of the following appropriate laminating adhesives: (1) Sta-Smooth Compound or Sta-Smooth Lite for fast hardening; (2) All-Purpose Joint Compound for spreading on the back surface of the finish layer boards; (3) drywall adhesive meeting ASTM C 557.

Base layer is applied on ceilings, then sidewalls, secured with 1 1/4" Type W Screws 12" o.c. on ceilings, 16" o.c. on walls; nails located 7" o.c. on ceilings; 8" o.c. on sidewalls; staples 5" o.c. on ceilings and 6" o.c. on sidewalls.

Finish layer is temporarily nailed or braced until adhesive dries. On walls, prefinished boards, applied vertically, can be pre-bowed, nailed just top and bottom.

RECOMMENDATIONS

- Double layer gypsum board application over wood framing is recommended for the ultimate in wall surfacing and in areas where increased fire protection and better sound insulation are desired between rooms. (For test results see pages 13-14 of this guide.) Custom built homes, commercial buildings and party walls between apartments would be considered appropriate areas for double layer application.

SPECIFICATIONS

See CSI 3-Part format Generic/Proprietary Specifications on page 120.

- 2. Laminating is an excellent way to apply Durasan, the vinyl-surfaced gypsum board. This method eliminates any visible attachment.
- 3. Sta-Smooth Compound or Sta-Smooth Lite is recommended for laminating as well as for joint treatment where fast hardening is required.

LIMITATIONS

- 1. Joints of succeeding layers must not fall at the same location. For greatest strength, it is recommended that the boards of each layer be staggered so that joints of each layer are at least 10" apart.
- 2. During cold weather, maintain a room temperature of not less than 40°F during mechanical attachment of gypsum board, and between 50°F and 70°F for 48 hours before lamination, joint treatment, texturing and decoration, and continuously thereafter until completely dry.

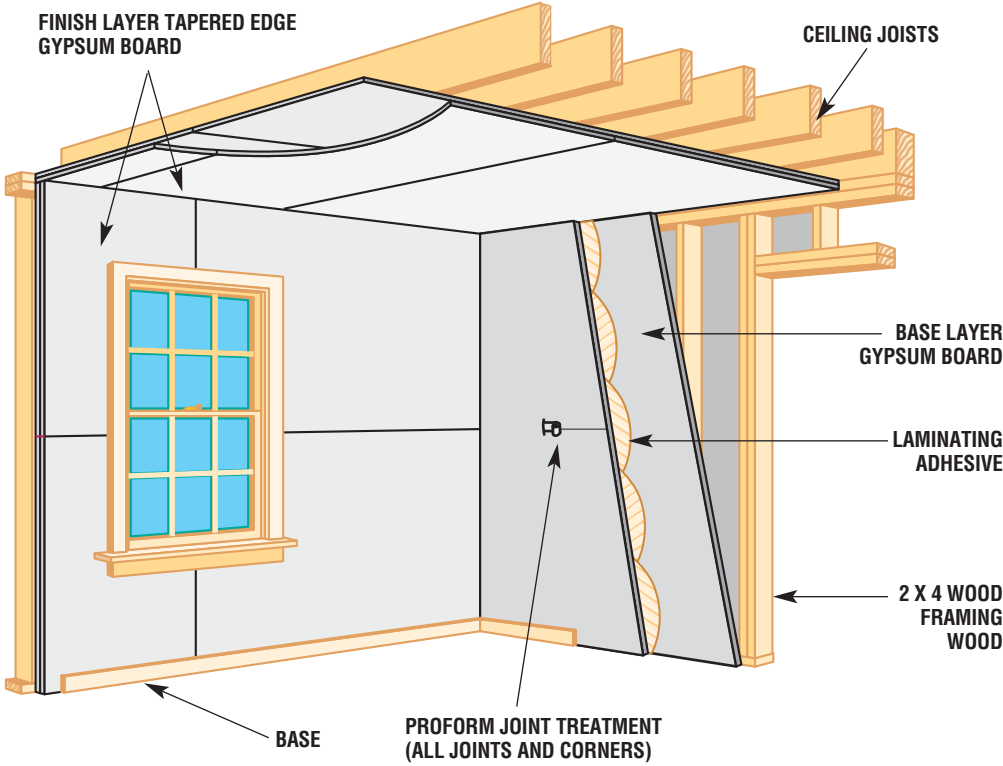

09 29 00

**SOUND TRANSMISSION CLASS 45
FIRE RESISTANCE RATING 1 HR.**

**SOUND TRANSMISSION CLASS 58
FIRE RESISTANCE RATING 2 HRS.**

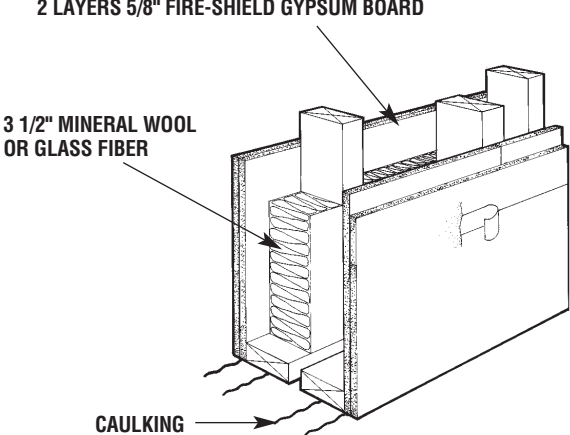
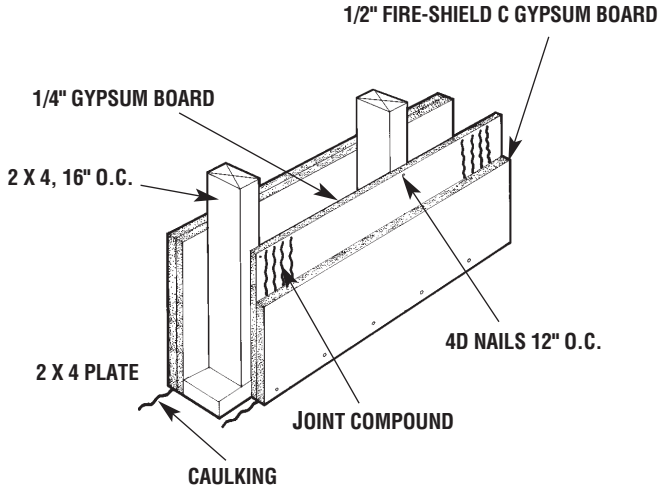

Resilient Furring Channel Construction

DESCRIPTION

Resilient Furring Channels are fabricated of galvanized steel with expanded metal legs that provide resiliency to reduce sound transmission through wood framed wall and ceiling assemblies.

STANDARD APPLICATION

Resilient Channels have punched holes spaced 1" o.c. in the leg flanges to facilitate fastening to framing members spaced either 16" or 24" o.c. The 12' long channels are applied perpendicular to the framing members and spaced not more than 24" o.c. Gypsum board is then attached to the Resilient Channels with power driven, Type S Drywall Screws spaced 12" o.c.

RECOMMENDATIONS

1. Construction, as shown in the detail below, is recommended to achieve sound and fire-rating as shown on pages 11-26.
2. A 3" wide strip of 1/2" thick gypsum board should be used at the floor line to assure a solid base for attaching the gypsum board and the base. An additional strip of gypsum board or a Resilient Furring Channel should be used at the ceiling line.

3. The point of intersection between the wall and floor shall be caulked prior to application of baseboard to obtain the best sound isolation.
4. On wood studs fasten channel through alternate flanges at each stud using 1 1/4" GWB-54 Nails or Type W Drywall Screws. Fasten both flanges at channel ends.
5. Resilient Furring Channels should be fastened to wood joists with one Type W Drywall Screw at each joist in alternate flanges. Channel ends may fall on or between joists but must be fastened to prevent any sliding movement which could create squeaking noises. When channel ends fall between joists, overlap approximately 1 1/2" and screw-attach through both legs into a wood block held above the channels, or overlap approximately 6" and fasten both channels near ends with 3/8" Type S Pan Head Screws.

LIMITATIONS

1. Spacing of Resilient Furring Channels should not exceed 24" o.c. nor span more than 24".
2. Use only 1/2" or 5/8" gypsum board with this system.

RECOMMENDATIONS

INSTALLATION (RESILIENT FURRING CHANNELS ON ONE SIDE OF PARTITION)

Wood framing shall be erected in accordance with conventional procedure, studs (16" o.c.) (24" o.c.). A 1/2" x 3" shim strip of gypsum board shall be nailed to the base plate continuously on the resilient side of the partition. An additional strip of gypsum board or a Resilient Furring Channel should be used at the ceiling line. Resilient Furring Channels shall be located horizontally, 24" o.c. max., and be secured through alternating flanges at each stud with 1 1/4" GWB-54 Nails or Type W Drywall Screws. Abutting channel ends shall be located over studs, shall be gapped and shall be fastened through both flanges.

INSTALLATION (RESILIENT FURRING CHANNELS ON CEILINGS)

Wood framing shall be erected in accordance with conventional procedure, joists (16" o.c.) (24" o.c.) Resilient Furring Channels shall be installed perpendicular to joists, spaced 24" o.c. and a maximum of 6" from the ceiling-wall line with Type W Screws through alternate flanges at each joist.

Where channel ends overlap at a joist, Type W Drywall Screws must be driven through both channels through both flanges into joist.

Where channel ends overlap between joists, wood blocking may be used to take Type W Drywall Screws driven through both channels through both flanges, or Type S Pan Head Screws may be used to fasten channel ends together.

APPLICATION OF GYPSUM BOARD

Attach gypsum board to Resilient Furring Channels with 1" Type S Drywall Screws 12" o.c. and to framing through filler strips with drywall screws 12" o.c. that penetrate framing 5/8" minimum.

Note: Screws used to attach gypsum board to resilient furring channels shall not contact wood framing.

DETAIL

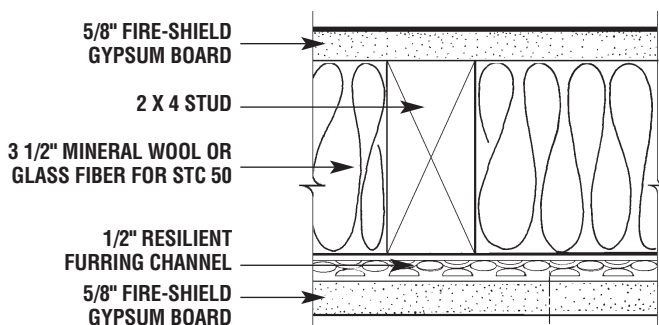

TYPICAL SECTION

SPECIFICATIONS

See CSI 3-Part format Generic/Proprietary Specifications on page 120.

INSTALLATION

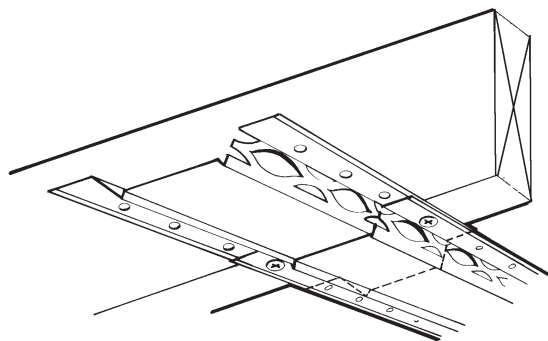

SPLICE ON JOIST
1 1/4" Type W Screws

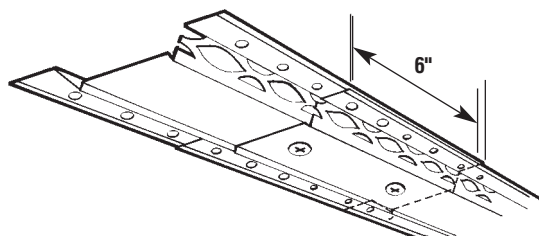

SPLICE BETWEEN JOISTS
3/8" Type S Pan Head Screws

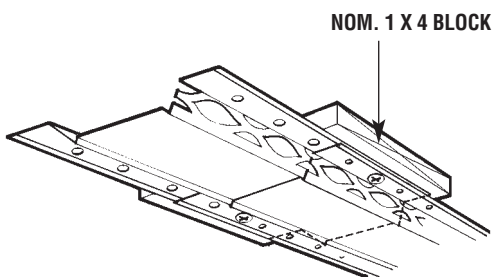

SPLICE BETWEEN JOISTS, ALT.
1 1/4" Type W Screws

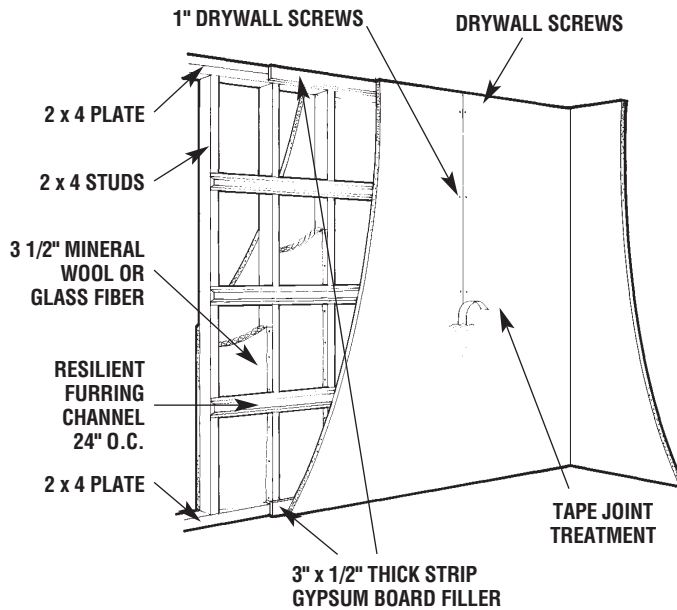

09 29 00

Gypsum Board Over Masonry

DESCRIPTION

A. Z FURRING CHANNEL

1. Application of Foam. Z Furring Channel is used to secure rigid insulation and gypsum board to masonry walls. Insulation thickness (1", 1 1/2", 2") determines depth of Z furring web. The channel is applied vertically and fastened to the masonry wall through the short (3/4") flange with suitable masonry fasteners 24" o.c. maximum. Application is progressive. After fastening each Z Furring Channel, a 24" wide floor-to-ceiling-high insulation board is fit between the wall and the wide (1 1/4") flange.

2. Application of Gypsum Board. Erect Gold Bond Gypsum Board either vertically or horizontally to the Z Furring Channels. Gypsum board edges or ends that run parallel to the channels shall be centered and abutted over channels. Fasten gypsum board with 1" Type S Drywall Screws spaced 12" o.c. When gypsum board erection is complete, finish all joints and screw heads in accordance with ProForm Joint Finishing System. Prefinished gypsum board may be laminated vertically to the channels with screws at top and bottom.

Limitations

Power driven fasteners should be used to secure furring only when wall is monolithic concrete. Regular concrete nails can be used for fastening to unit masonry. If block is old, test nailing should be done in advance to determine optimum size and type of nail.

B. LAMINATION

1. Application of Foam. Insulation may be urethane foam or extruded polystyrene. Expanded bead polystyrene is not recommended. For horizontal gypsum board

application, install wood furring strips (nominal 2" wide x 1/32" greater than the foam thickness) horizontally along the wall-ceiling and wall-floor angles, where horizontal gypsum board joints will fall, and around door and window openings. For vertical gypsum board application, furring strips are required at the horizontal wall-ceiling and wall-floor lines and around door and window openings.

Masonry surface must be dry, clean and free of dust, dirt, form release agents, oil, grease or water soluble materials. Treat painted masonry as recommended for laminating to painted surfaces. Apply adhesive to the foam insulation in 3/8" dia. beads continuously around the perimeter and through the field in the long direction with the beads spaced 16" o.c. **Contact adhesive manufacturer for compatibility with foam.**

Apply the foam boards horizontally to the wall with a sliding motion and hand press entire board to ensure full contact of adhesive and wall surface.

2. Application of Gypsum Board. ProForm All-Purpose Joint Compounds may be used. (Do not use water base compounds for laminating prefinished boards to foam.)

Permanent nails or screws 12" o.c. are required to fasten gypsum board to wood furring. Gypsum board must be installed a minimum of 1/8" from the floor. Use temporary nails or bracing as necessary to hold gypsum board boards in firm contact to the foam until adhesive has dried or set.

Limitations

1. Nails or screws used for attachment of gypsum board to furring strips must not penetrate through the furring.

- Power driven fasteners should be used to secure furring to monolithic concrete. Regular concrete nails can be used for fastening to unit masonry. If block is old, test nailing should be done in advance to determine optimum size and type of nail.
- During cold weather, room temperature between 50°F and 70°F must be maintained uniformly during application and until adhesive is thoroughly dry or premises are occupied. Provide adequate ventilation.
- Gypsum board is not recommended in areas where it will be exposed to excessive moisture or continued high humidity.

5. Since the use of foam plastic insulation is regulated by many building codes, consultation with local building authorities is recommended before installation.

Since unprotected foam insulation may represent a fire hazard, it should be covered promptly and completely with gypsum board.

DETAILS

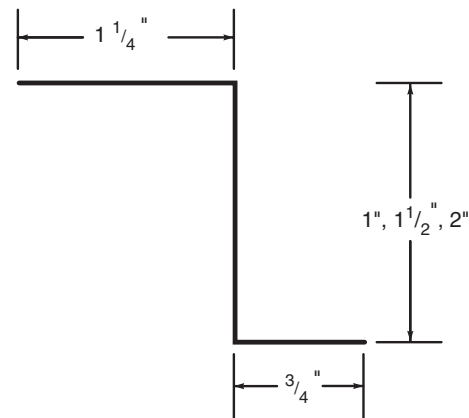

Z FURRING

SPECIFICATIONS

See CSI 3-Part format Generic/Proprietary Specifications on page 120.

RECOMMENDATIONS

Z FURRING

1. Begin application of Z furring members by positioning first piece vertically at a corner. Locate the piece on the wall adjacent to the wall being insulated first.
2. Insulation thickness determines distance of Z furring web from wall being insulated. At the appropriate distance, and with wide flange pointing toward applicator, secure Z furring with appropriate fasteners through short flange. (Note to Specifier: Power driven fasteners are not recommended for use with masonry block.)
3. Install 24" wide floor-to-ceiling insulation board, pressed snugly against web of first Z. Install next Z with wide flange overlapping edge of first insulation board. Fasten to wall through narrow flange.
4. Continue in this manner, with Z furring 24" o.c. to end of wall. Locate last Z so that web is located a distance equal to insulation thickness from adjoining wall. Cut last insulation board to fit remaining space.
5. At exterior corner, attach the Z through its wide flange, with narrow flange extending beyond the corner. Begin with a narrow strip of floor-to-ceiling insulation, wider than insulation thickness but not exceeding 3". Continue application of furring and insulation progressively as described above.
6. At windows, doors and trim areas, use wood nailers (nom. 2" wide x insulation thickness plus 1/32"). Use the nailers also at wall-floor angles to support trim and provide backing for base.
7. Apply gypsum board with 1" Type S Screws through flanges of Z furring, 12" o.c.

LAMINATION

1. Masonry or monolithic concrete shall be above grade, dry, free of dust, loose particles, oil, grease or other foreign material.
2. Joint compound used as adhesive shall be mixed to a consistency thick enough to allow a 2" daub to stick to the underside of a broad knife held parallel to the floor.
3. Apply 2" to 2 1/2" diameter daubs of adhesive 1/2" thick, 16" o.c. in both directions to the masonry wall. The adhesive layout must provide for a row of daubs located a maximum of 2" from board ends, and care must be exercised to center daubs on vertical joints. No more adhesive shall be applied to the wall than will be covered with board in 15 minutes. Approximate coverage for joint compound (powder) used as an adhesive is 30-35 lbs./1000 sq. ft.
4. Cut gypsum board to allow for 1/8" to 1/4" clearance between board and floor to prevent potential wicking.
5. Install gypsum board by hand pressing each board tight to the wall making certain that all daubs are in positive contact with the board.
6. Support boards at each corner to keep them from slipping to the floor by use of a concrete nail driven through a small block of nominal 1" lumber.
7. Butt boards to each previously positioned board to ensure flush joints.
8. If necessary to hold boards straight, plumb and in proper alignment, drive masonry nails through small wood blocks and into masonry at high points only. After adhesive is dry (24 - 48 hours) remove temporary nails.
9. Fill all holes and treat joints with tape and joint compound.

INSTALLATION

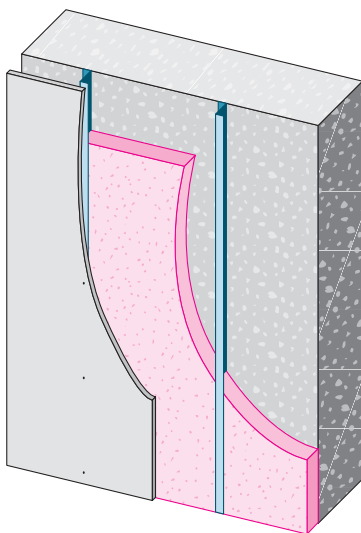

Z FURRING CHANNEL

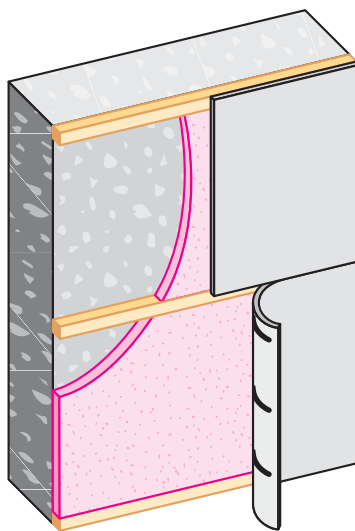

HORIZONTAL INSTALLATION WITH DRYWALL ADHESIVE

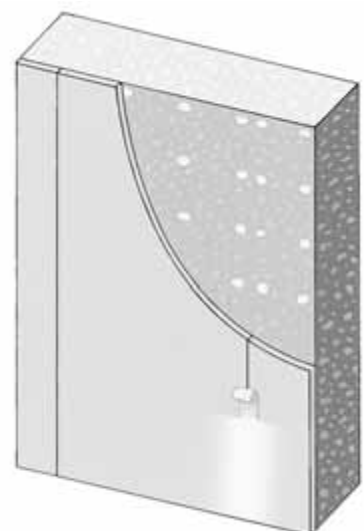

DAUB METHOD USING JOINT COMPOUND

Solid Laminated Partitions

DESCRIPTION

Laminated Partitions have been developed for use where sturdy, nonload-bearing walls are desired. The total thickness is nominal 2". 1" Fire-Shield Shaftliner is used between face layers of gypsum board.

PHYSICAL PROPERTIES

A. Fire Resistance. Fire endurance ratings have been established by the following tests:

FM WP 671 - 1 HOUR:
1/2" Regular Gypsum face boards and ProForm Brand Sta-Smooth joint compound* as laminating compound.

UL U505 - 2 HOUR:
5/8" Type X Fire-Shield face boards and ProForm Brand Sta-Smooth joint compound* as laminating compound.

UL U525 - 2 HOUR:
1/2" Fire-Shield Type C face board and ProForm Brand Sta-Smooth joint compound* as laminating compound.

UL U529 - 2 HOUR:
1/2" Fire-Shield Type C face boards and ProForm Brand Sta-Smooth joint compound* as laminating compound.

B. Sound Isolation. An STC rating of 34 has been achieved in tests conducted in accordance with ASTM E 90.

C. Economical. The laminated partition offers a substantial saving in installation time and subsequently in labor costs over other types of solid partitions. The 1" gypsum core is quickly and easily installed and the large sheets of gypsum board provide a dry finish surface in minimum time.

LIMITATIONS

The laminated partition is adapted to any type of building for nonload-bearing partitions not exceeding 12' in height. Further limitations to height are based on the partition length in the table below.

*Required for fire rating.

DETAILS

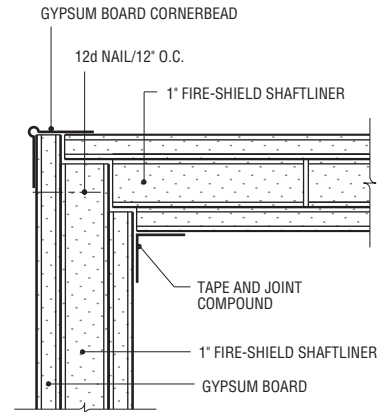

CORNER WALL DETAIL

09250U
Scale: 3" = 1'-0"

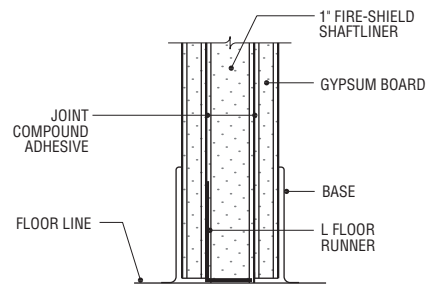

VERTICAL SECTION USING METAL FLOOR RUNNER

09250T
Scale: 3" = 1'-0"

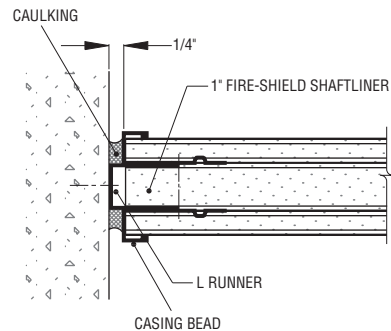

ANCHORAGE TO CONCRETE CEILINGS, WALLS OR COLUMNS

09250V
Scale: 3" = 1'-0"

TECHNICAL DATA

Maximum Ceiling Height	Partition Length Between Restraints
12' (3658 mm)	14' (4267 mm)
11' (3353 mm)	20' (6096 mm)
10' (3048 mm)	Over 20' (6096 mm)

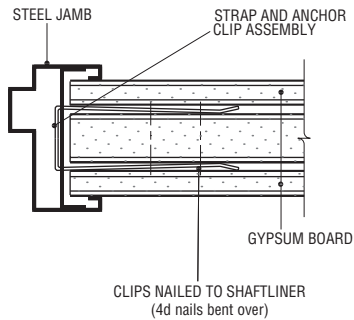
**JAMB DETAIL**

09250X

Scale: 3" = 1'-0"

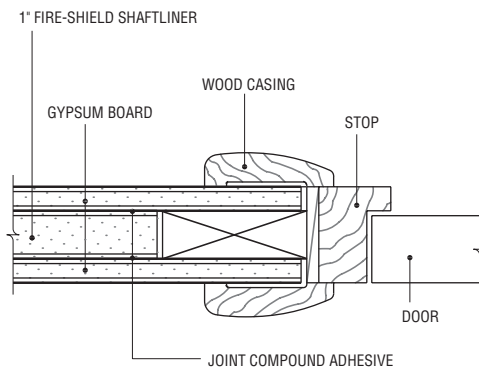
**WOOD JAMB DETAIL**

09250W

Scale: 3" = 1'-0"

RECOMMENDATIONS

1. Secure floor runner to floor with approved fasteners 24" o.c. Ceiling runner shall be secured in an appropriate manner to the ceiling construction. The L runner shall be used as both floor and ceiling runners in Fire-Rated construction.
2. The 1" Fire-Shield Shaftliner, cut 1/4" shorter than wall height, shall be installed vertically and shall be fastened to the floor and ceiling runners with two 1 5/8" Type S Drywall Screws, each located 2" from each edge of the Shaftliner boards.
3. Sta-Smooth Compound shall be applied evenly with a notched spreader (with 1/4" x 1/4" notches, 1 1/2" o.c.) to the back side of the 4' wide, ceiling height gypsum board face boards. Install the boards vertically to both sides of the Shaftliner. Stagger

board joints 12" from the Shaftliner joints and 24" from joints on each side of the wall.

Face boards are then screwed, 12" o.c. to the top and bottom runners with 1 7/8" Type S screws and are secured to the Shaftliner with 1 5/8" Type S Drywall Screws spaced 24" o.c. horizontally and vertically to include screws along the vertical edges of each board.

Gypsum board joints shall be reinforced with paper tape and finished with joint compound.

4. Door frames shall be vertical, plumb and true, and shall be securely anchored to floor and ceilings as shown on the plans.
5. Completed partition shall be straight and plumb.

SPECIFICATIONS

See CSI 3-Part format Generic/Proprietary Specifications on page 120.