

# TB118

Applies to models:

NVx, VPC, CPX, OUH, CP, CA & CA-AG



CLICK ANYWHERE on THIS PAGE to RETURN to WHITE RODGERS CONTROLS & MANUALS at [InspectApedia.com](http://InspectApedia.com)

[www.powrmatic.co.uk](http://www.powrmatic.co.uk)

## Instruction for replacing a spares Fan Limit Stat.



## General Information

A Fan/Limit stat is pre-set to corrected values prior to the heater leaving the factory. If a spares item is fitted, these settings are factory default and will require resetting to their respective heater.

This bulletin describes the parts required and procedures to be carried out when replacing the original fan/limit stat with a new one.



Note: This Honeywell Fan/Limit stat and following procedure can only be used for Powrmatic heaters which utilise either a White Rodgers Fan/Limit stat or a Honeywell Fan/Limit stat with a single white button.



**Important: For older Honeywell Fan/Limit stats with a red and white button, you will require the retrofit kit - Powrmatic part 142403600/KIT**



fig.1 Honeywell Fan/Limit Stat L4064B



fig.2 White Rodgers Fan/Limit Stat 5D51

## Tools required



Flat head screwdriver



Pozi head screwdriver



Electrical screwdriver



Thin Nosed Pliers



Wire strippers



Honeywell Fan Limit Stat part # 143000306 including: Technical bulletin (TB118)



**WARNING:** Always switch off and disconnect electricity supply and close service valve before carrying out any servicing or replacement of failed components.

## Honeywell L4064B Fan/Limit Stat

Locate existing stat and remove the front cover

Make a note of the actual wire colours used on the existing fan/limit stat in the sketch below.

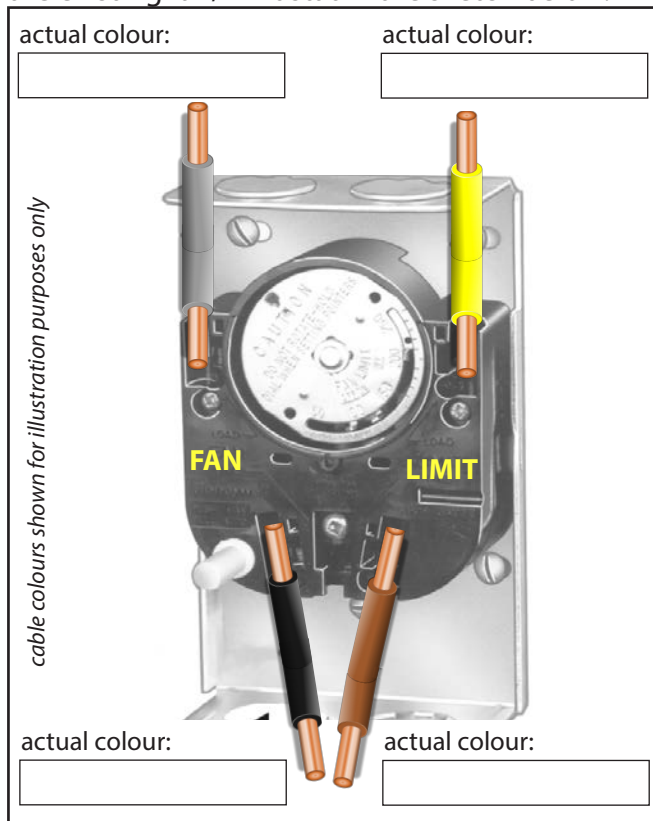

Disconnect the four wires by pushing a screwdriver against each tab in turn and withdrawing each wire.

Remove the old fan/limit stat by removing the fixing screws and fit the replacement.

Reconnect the wires in the same configuration as the sketch *above* by pushing a screw driver against each tab in turn.

Remove the brass jumper as shown below.

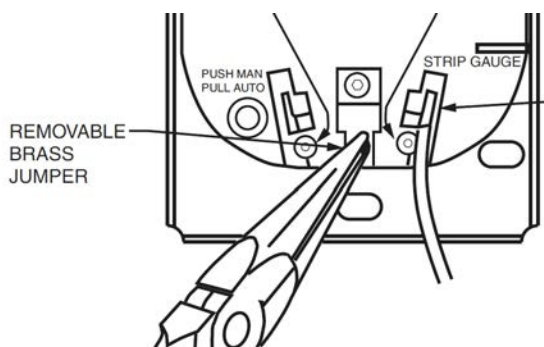

## White Rodgers 5D51 Fan/Limit Stat

Locate existing stat and remove the front cover

Make a note of the actual wire colours used on the existing fan/limit stat in the sketch below.

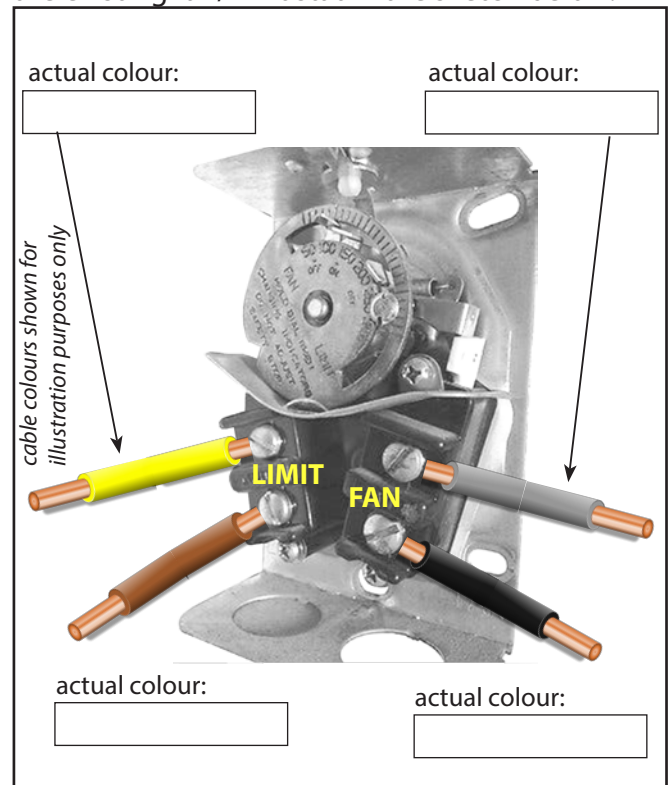

Using a flat head screwdriver, unscrew the four wires at each tab in turn and withdrawing each wire.

Remove the old fan/limit stat by removing the fixing screws and fit the replacement Honeywell stat.

Using a screwdriver, reconnect the wires in the same configuration as the sketch *shown opposite*.

Remove the brass jumper as shown below.

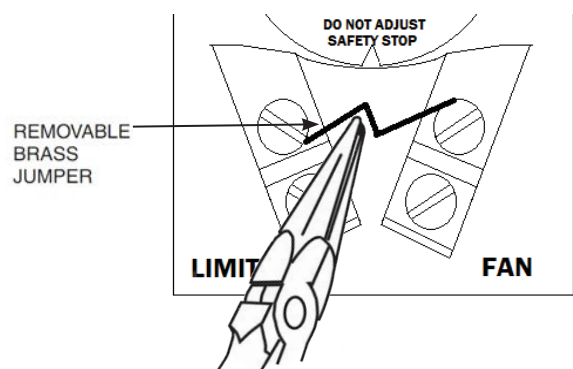





Note: On certain model sizes, the limit temperature required may be higher than the factory set limit stop.

To increase this limit stop carefully push a stiff wire through the hole located by the word "CAUTION" on the dial.

Whilst holding the dial, move the limit stop to the desired setting and then remove the wire.

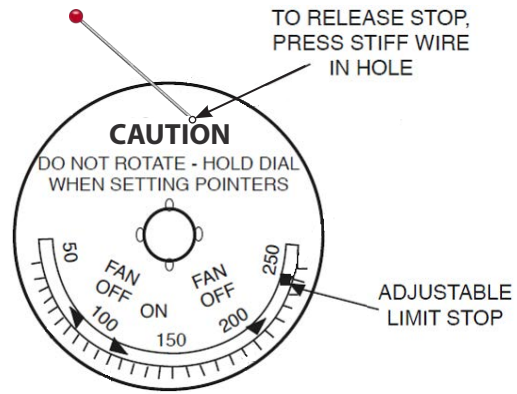

## Fan/Limit Stat Settings

Model	Size(s)	Fan Off (°F)	Fan On (°F)	Limit (°F)
NVx	All	86	122	212
CPx	30-90 & 150-175	86	122	212
	120	86	122	230
	200-300	86	122	240
VPC	30-52	86	122	212
	80-130	86	122	230
OUH	20	86	122	240
	30-60	86	122	194
CP	100-150	86	122	194
	200-800 & 1000	86	122	230
	300-700	86	122	212
CAG	100-400	86	122	230
	500-2000	86	122	212
EAG	100	86	122	194
	150-300	86	122	230
	400-2000	86	122	212
CA-G (pre CE)	400-1500	86	122	194
CP-G (pre CE)	500, 800 & 1000	86	122	194
NCA-G (pre CE)	100-300	86	122	194
CA-O	400-1500	86	122	194
CP-O	100-1250	86	122	194
NCA-O	100-300	86	122	194
CA-AG	100-400	95	122	194
CP-AG	100-400	95	122	194
NCA-AG	100-400	95	122	194

### HEATING DIVISION

Hort Bridge  
 Ilminster, Somerset TA19 9PS  
 Tel: 01460 53535  
 Fax: 01460 52341



Every effort is made to ensure accuracy at time of going to press. However as part of continued product improvement, we reserve the right to alter specification without prior notice.