

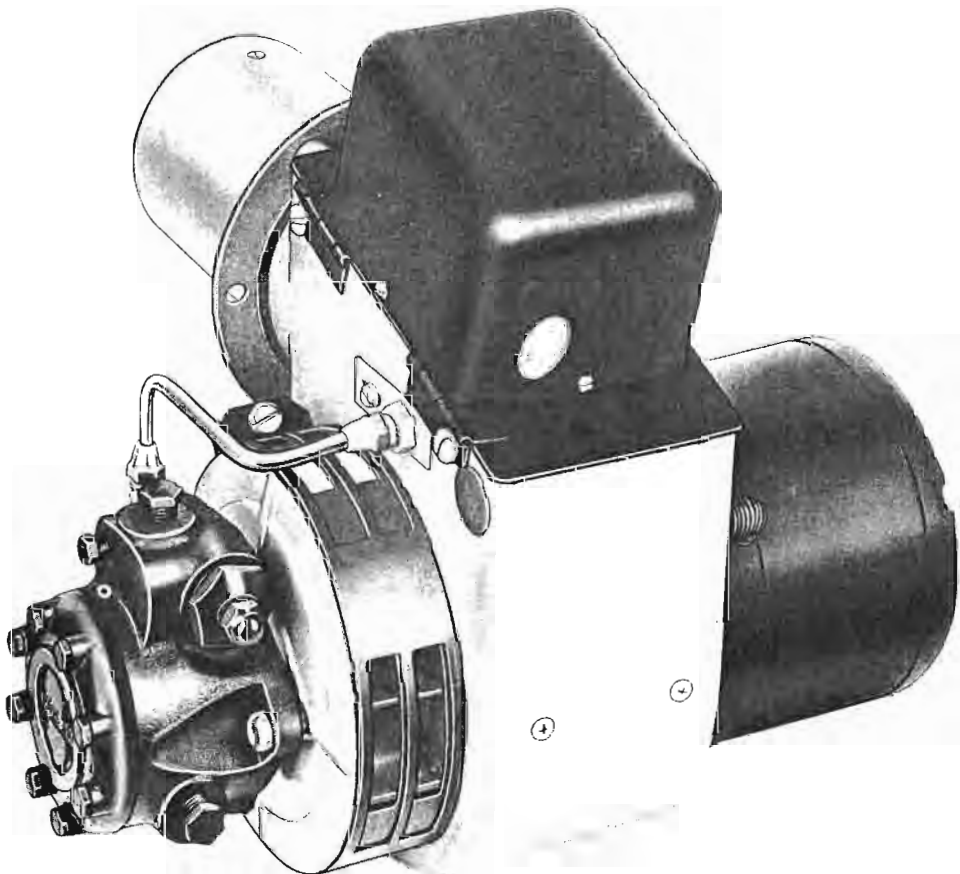

INSTALLATION MANUAL

FOR MODEL E OIL BURNER



WAYNE HOME EQUIPMENT CO., INC.
801 GLASGOW AVENUE, FORT WAYNE, INDIANA 46803, U.S.A.

OIL BURNER CERTIFICATE

AS REQUIRED BY COMMERCIAL STANDARD CS75-56

The Oil Burner Model No., Serial No., installed at
(Make)

..... bears a label evidencing compliance with commercial Standard CS75-56, and
(Address of Installation)
has been installed in accordance with the instructions in the manufacturer's installation manual and in conformity with local regulations, codes, and ordinances.

The boiler (), furnace (), is a No., and the heating load consists of :
(Make)

1. Btu, or square feet steam (), hot water () radiation; and
2. Btu, or square feet of equivalent steam (), hot water () radiation in domestic hot water load; or
3. Btu, or square inches of cross-sectional area of warm air supply pipes measured at the furnace take off; or
4. Btu, or square feet of equivalent steam (), hot water () radiation in the following special load:

.....
All necessary permits have been secured, and the installation has been tested in accordance with the test procedure of Commercial Standard CS75-56 and the following readings taken:

CO. { Over Fire.....
At Breaching..... } Stack Temperatures at breaching..... °F

Draft { Over Fire.....
At Breaching..... } inches H₂O. Firing Rate..... gals./hr.

All controls and limiting devices have been checked for proper operation.....

Fuel used, Grade No. of Commercial Standard CS12-48.

Field service equipment smoke scale reading

The above test results are certified to be true:

For service call: (Name of Company making installation)

..... (Name) Per (Signature)

..... (Address) (Address)

..... (Telephone) (Telephone)

Date

Fill pipe should not be less than 2 in. pipe and should slant toward the tank. It should terminate outside the building at a point not less than 4 feet of any building opening at the same or lower level. Fill terminal should be closed tight and provided with a metal cover designed to prevent tampering.

Illustration I

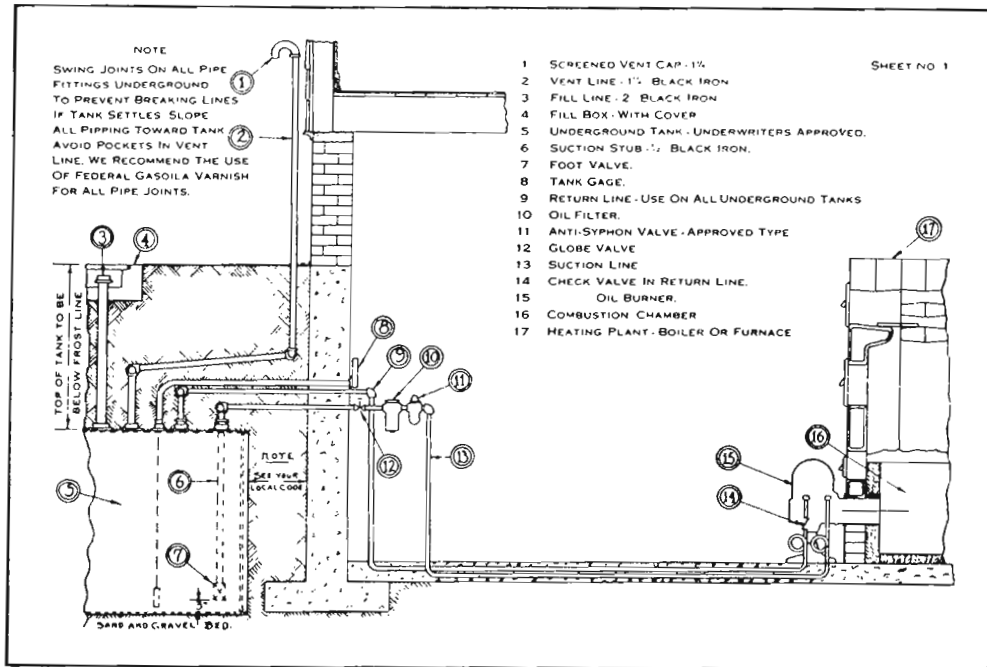

Typical Underground Tank Installation

Illustration II

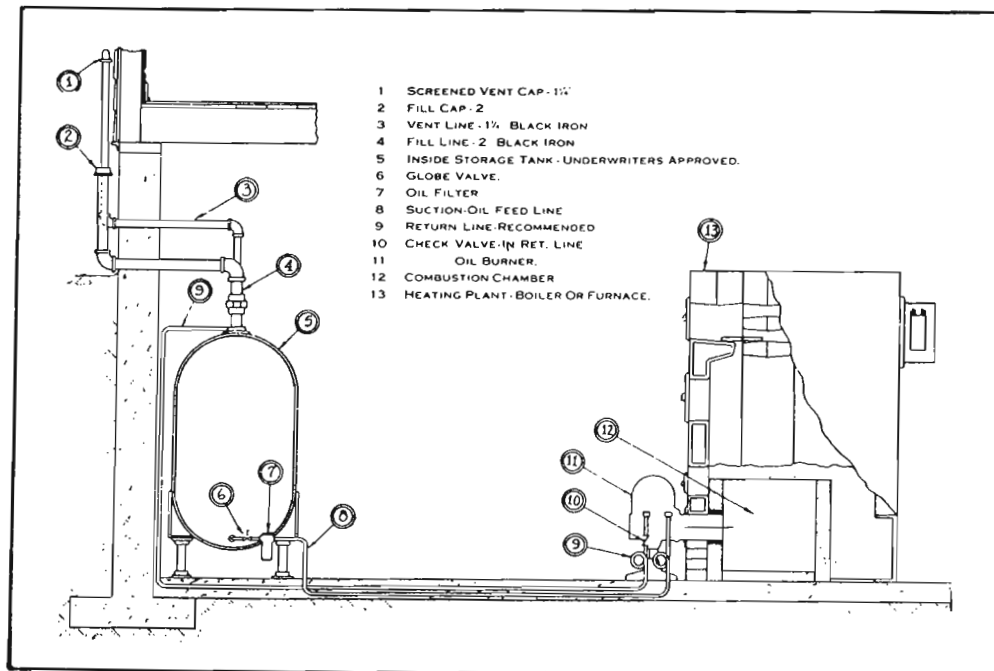

Typical Inside Tank Installation

BOILER ROOM AIR REQUIREMENTS

Tight boiler rooms shall have opening of not less than the area in square inches of boiler breeching to admit fresh air for burner operation.

WIRING AND CONTROLS

Wiring diagrams are furnished with each control and due to the many types of heating plants and methods of controlling the operation, a complete wiring diagram for each installation cannot be furnished in this pamphlet. Having the individual control diagrams, a competent electrician can make the proper hook-up. Local wiring codes and National Electrical Code, or Canadian Electrical Code, whichever applies, should be adhered to in all cases. A typical diagram is shown in Chart II.

Chart II

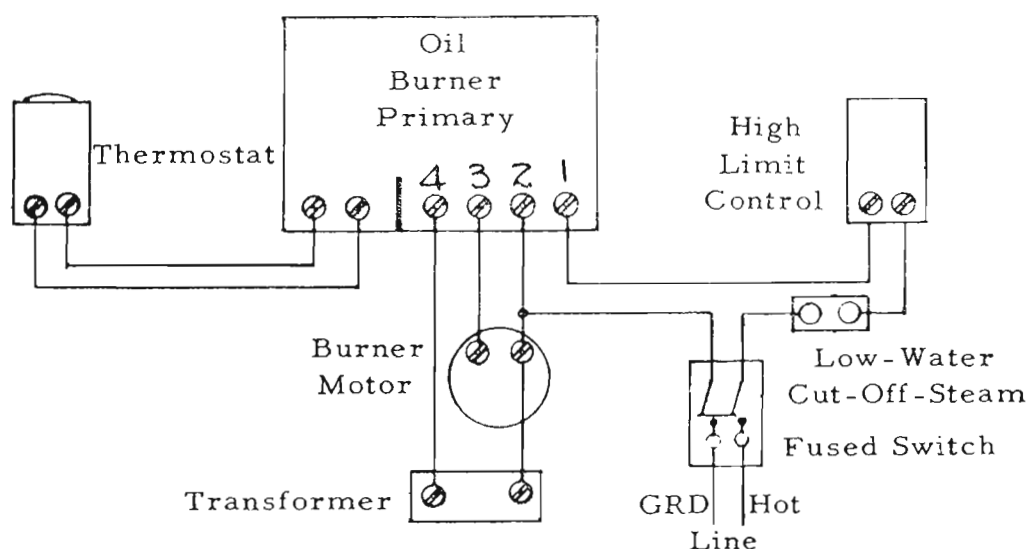

SPECIFICATIONS FOR FUEL (Commercial Standard CS 12-40)

Fuel oil not heavier than No. 2. A minimum flash of 110° F. and a maximum of 230° F. The pour point 20° C. Water and sediment not more than one-tenth of one percent. Distillation Temperature a minimum of 600° F. and a maximum of 675° F. at 90% Point of Recovery. The viscosity of the fuel at Saybolt Universal at 100° F.: Maximum of 45 seconds.

INSTALLATION REQUIREMENTS AND PERFORMANCE TESTS (When CS 75-42 Requirements Must Be Met)

INSTALLATION REQUIREMENTS:

Size—The burner shall be of adequate size for the boiler or furnace and the connected heating load as recorded on the oil burner certificate by the installer.

Certificate—Following installation of the burner, certain test data shall be obtained and recorded by the installer on the oil burner certificate to be placed with each oil burner installation. The

GENERAL

THE INSTALLATION OF THE BURNER SHALL BE IN ACCORDANCE WITH THE REGULATIONS OF AUTHORITIES HAVING JURISDICTION.

HEATING PLANT

Before installing this Oil Burner in a conversion (converting coal firing to oil firing) installation the heating system should be carefully inspected for defects and cleanliness, if proper performance is to be obtained. An oil burner is only a means of supplying heat to the fire box and from there the heating system must absorb and circulate the heat.

The flue passages and heat absorbing surfaces must be clean to assure maximum heat transfer to the furnace or boiler. Soot and fly ash act as insulators retarding the transfer of heat.

All doors, openings and cracks should be cemented air-tight to eliminate air infiltration into the heating plant causing heating losses. Inspect smoke pipe and chimney for elimination of leaks and obstructions. Remove damper in smoke pipe and install a mechanical draft adjuster, same size as smoke pipe.

COMBUSTION CHAMBER

The purpose of a combustion chamber is to maintain a high flame temperature by reflecting the heat back into the flame. A high flame temperature assures greater combustion efficiency and lower stack losses. An insulating refractory type combustion chamber is recommended for use with this burner. This type attains maximum temperature rapidly to give the desired high flame temperature.

It is important to select and install the recommended size combustion chamber on a conversion job (See Chart I). The atomized oil must burn in suspension and the flame must not touch the sides or the bottom of the chamber or smoke will result. To eliminate the smoke, excess air will be required, resulting in high stack temperature and lower combustion efficiency.

CHART I

Rating No.	Nozzle Size	Combustion Chamber				Boiler Rating				Warm Air Furnace Size	B.T.U. Input
		Round Dia.	Rectangular W. L.	Nozzle To Floor	Overall Height	Gross EDR		IBR Net			
						Steam	Water	Steam	Water		
10	.60	9	8 x 8	4	9	234	375	150	240	18	84,000
	.75	10	9 x 9	4	9	292	469	188	300	18,20	105,000
	1.00	11	10 x 10	4 1/2	10	390	624	250	400	22,22	140,000
15	1.25	12	11 x 11	5	11	488	781	312	500	22,23	175,000
	1.35	12	11 x 11	5	11	526	844	337	540	22,23	189,000
	1.50	13	11 x 12	5	12	585	936	375	600	24,25	210,000
20	1.65	14	12 x 13	5	13	644	1031	413	660	25,26	235,000
	1.75	14	12 x 13	5	13	683	1092	437	700	26,27	245,000
	2.00	15	13 x 14	5 1/2	13 1/2	780	1250	500	800	27,28	280,000
30	2.50	17	14 x 16	5 1/2	14	975	1562	625	1000	30,32	350,000
	3.00	18	15 x 17	6	14 1/2	1170	1875	750	1200	34,36	420,000

Install the combustion chamber in the heating plant so the end of the oil burner air tube can be set flush with the inside front wall of the chamber. The combustion chamber bottom should be made of refractory material to a depth of 1 to 1½ inches. After the chamber has been set and oil burner installed on a conversion job we recommend the use of Expanded Mica for fill around the outside of the chamber and the sides of the heater. This is an excellent insulator and will prevent the transfer of heat from the combustion chamber to the lower portion of the heater.

CHIMNEY REQUIREMENTS

The chimney requirements for domestic oil burner installations are the same as used when the heater is coal-fired and in no case should they be smaller than 8 x 12 flue lining. All makers of heating equipment give the size and height of chimneys best suited to their units and when the heater is to be oil-fired these same dimensions should be maintained, as it is very essential that the products of combustion have ample smoke pipe and chimney volume in order that there will be no back draft or pressure in the heating plant. The excess draft can be readily controlled by the use of a barometric damper set into the smoke pipe. This damper shall be the same size as smoke pipe with full opening cut in the smoke pipe. The heater should have from .05 to .15 inches of water (as measured with a reputable draft gage) in the smoke pipe, depending on the size of the heater and amount of oil being used. Domestic installations up to 2½ gallons per hour should have .05 to .08 inches in the smoke pipe and .01 to .03 inches measured over the fire through a small opening in the front of the heater. Manual operated smoke pipe dampers shall be removed or locked in the opening position.

We recommend that the chimney size be as outlined in the catalog of the heater manufacturer and can assume no obligation if this is not carried out and the burner does not operate satisfactorily from lack of chimney draft.

TANKS AND PIPING

Local rules and regulations must be adhered to regarding tank and burner installation. For U.S.A. installations Underwriter's Laboratories Tank Specifications must be used.

If tank is buried outside, the pipe connections to it must be made with swing joints to prevent pipe breakage in case the tank settles. Inside tanks should not be located within 7 feet, horizontally, of any fire or flame.

All Pipe work and fittings must be air-tight and only high grade material used. Pipe lines should be run direct as possible, free of traps, out of the way, and if possible place lines beneath floor. Copper tubing is most desirable wherever possible. On gravity flow from inside tanks ¾ in. O.D. tubing is ample size for runs less than 50 feet, longer runs require ½ in. O.D. tubing. On outside underground tanks where a suction lift is present use ½ in. O.D. tubing.

On all installations requiring a suction lift, a return line must be run to properly handle any entrained air in the oil or system. Failure to do so will prevent satisfactory fuel pump operation. (See Fuel Unit Instruction Sheet).

Tank vent should not be less than 1¼ in. pipe size and should slant toward the tank. It should terminate outside the building at a point not less than 2 feet vertically or horizontally from any window or other building opening. Vent should be provided with weatherproof hood and should be sufficiently high to prevent snow and ice obstruction.

test shall cover the following points: CO₂ in the flue gas by analysis, draft, stack temperature, firing rate, and smoke. (Certificate packed with burner).

TEST DATA REQUIRED ON CERTIFICATE:

- (1) CO₂ in the flue gas by analysis shall not be less than 8 percent.
- (2) Draft—The draft shall be in accordance with specifications in the manufacturer's installation manual. An automatic draft regulator or its equivalent is required.
- (3) Stack Temperature—The stack temperature shall be measured on the boiler side of automatic draft regulator and not more than 12 inches from the boiler smoke connection. The stack temperature shall be measured at the certified firing rate. If an automatic draft regulator is built into the boiler or furnace such regulator shall be closed when the stack temperature is measured.
- (4) Firing Rate—The firing rate shall be based on the burner manufacturer's recommendation for the existing total connected load. Burner shall be fired at that rate as a minimum, but not to exceed 25 percent additional for the maximum rate.
- (5) Smoke—During the above test, there shall be no visible smoke at the chimney.
- (6) Installation Manual—The burner shall be installed in accordance with manufacturer's manual.

INSTALLATION TEST PROCEDURE:

Equipment—The following equipment shall be available on each oil burner installation before the tests are started:

- (a) Where the oil rate is not indicated on the nozzle tip, a suitable device for determining the rate in terms of gallons per hour fed to the burner shall be used. This may be in the form of a graduated glass vessel. Nozzle tips furnished with this burner are marked.
- (b) A suitable flue-gas analyzer for determining the percentage of CO₂ in the flue gases.
- (c) A suitable draft gage, graduated in hundredths of an inch of water.
- (d) A suitable thermometer to indicate the flue-gas temperatures.
- (e) Provision for inserting a thermometer into the flue pipe as follows: Not more than 12 inches from the boiler or furnace outlet, measured on the center line of the flue pipe, there shall be a hole not more than 1/2 inch in diameter, located at the side of the pipe on the center line so that the thermometer may be inserted horizontally. The thermometer is to be placed so that the sensitive element is one-fourth of the pipe diameter from the near side of the flue pipe. The opening around the thermometer stem shall be sealed to prevent air leakage. The same opening may be used for checking draft and sampling flue gases.

NOTE: Other things being equal, flue-gas temperature may be expected to be higher by some 50° F. if the smoke pipe is insulated. Stack temperature is largely controlled by boiler design. High stack temperatures do not necessarily condemn the burner.

(f) In addition to the above, provision shall be made on the boiler or furnace for inserting a small tube into the combustion chamber for measuring the draft. The area of the opening shall not exceed that of a 1/2 inch diameter round hole (1/4 inch pipe tap).

TEST PROCEDURE: The test procedure is as follows:

(a) The burner shall be operated and the fuel rate adjusted to that required for the particular installation.

(b) The draft then shall be adjusted to meet the burner manufacturer's specifications both over the fire and at the breeching.

(c) Combustion air adjustments are to be made to give the highest CO₂ without visible smoke (unburned carbon) at the chimney. If the minimum required percentage of CO₂ cannot be obtained in the breeching it will be permissible to take CO₂ over the fire, which will be acceptable. In that event, both CO₂ readings shall be recorded on the certificate. A considerable difference between the two CO₂ readings indicate a leak of air into the flue passes of fire box of the boiler.

(d) Stack temperature shall be recorded after 10 minutes of operation after reaching steaming temperature for steam boilers, or 180° F. water temperature for hot water boilers, or 125° F. bonnet temperature for hot-air heating plants.

READINGS: During the period of operation to permit flue-gas temperatures to reach maximum, periodic readings of draft, CO₂ and oil rate shall be taken and the average recorded on the certificate. All controls and limiting devices shall be checked for proper operation.

OIL BURNER

GENERAL

These burners are furnished in several air delivery combinations to assure maximum combustion efficiency by proper air and oil ratios through the entire range of the burner from 0.60 GPH to 3.00 GPH Incl. for 60 cycle and 0.60 GPH to 2:50 GPH Incl. for 25 and 50 cycle units.

These various air delivery combinations are designated by a rating number which suffixes the model number of the burner. Only two burner parts are effected in covering the entire capacity range of the burner, namely: Air cone and baffle plate. See Chart III for the proper cone and plate diameter for the rating desired.

All burners are shipped with a 3 3/8 in. O.D. 4 in 1 multiple steel baffle plate which may be sized to the required diameter as specified by Chart III for the firing rate in a specific installation. Baffle plate is sheared to provide 3 in., 2 1/2 in. and 2 in. O.D. diameters with segmented tie-in ribs. These tie-in ribs may be easily broken with pliers. Each ring should be broken off successively beginning with the outer ring until the desired baffle size is attained.

This model burner is furnished in three types, namely: Base Mounted (for conversion installations), Rigid Flange Mounting and Adjustable Flange Mounting. Air tubes are supplied in 6 in., 8 in., 10 in., 15 in., and 23 in. lengths to permit proper installation into the many types of heating plants. When burner is furnished as a part of an oil heating unit the proper type and air tube length will be supplied and may not necessarily conform to the above.

CHARTS III

60 Cycle				25 and 50 Cycle			
Rating No.	Rating Gal. Per Hr.	Air Cone Bore	Baffle Plate Dia.	Rating No.	Rating Gal. Per Hr.	Baffle Plate Dia.	Air Cone Bore
10	From 0.6 thru 1.00	2 1/4	3 3/8	1	From 0.6 thru 1.00	3	2 1/4
12	From .85 thru 1.25	2 1/4	3	2	From 1.00 thru 1.50	none	2 1/4
15	From 1.00 thru 1.50	2 1/2	2 1/2	3	From 1.50 thru 2.00	2	3
20	From 1.50 thru 2.25	3	2	4	From 2.00 thru 2.50	none	3
30	From 2.25 thru 3.00	3	none				

NOTE: This chart normally covers conversion installations. For some types of oil-fired units the combinations shown do not apply, and in these cases a supplementary page is attached to this manual.

BURNER ADJUSTMENT

Removing Gun Assembly. Disconnect the oil line at the fan housing and remove lock nut on copper tube fitting. Remove transformer hold-down screw in upper left hand corner and swing transformer to right on hinge clips. Gun Assembly can now be removed through this opening.

BURNER NOZZLE

We recommend the use of 80-degree nozzles wherever possible but we realize that there are some boilers that this is not possible in which case other degree nozzles can be used. All nozzles shipped with oil burners will be 80-degree unless otherwise specified before shipping.

Check nozzle size as to conformance to installation requirements. Install nozzle by screwing into hexagon adaptor. In cleaning the nozzle, the rotor slots and orifice should not be touched by any material which will scratch or damage these surfaces. Toothpick or thin piece of wood will suffice. Clean screen with a solvent or hot water.

Nozzle Adaptor: This burner is equipped with a dribble-proof nozzle adaptor which will accomplish intended results only when installed with the stamped word "TOP" in the correct position.

Spacing of Electrodes: The electrodes should be spaced $\frac{1}{8}$ in. apart. They should extend $\frac{1}{8}$ in. beyond the end and $\frac{1}{2}$ in. above the center of the nozzle tip as shown in drawing below.

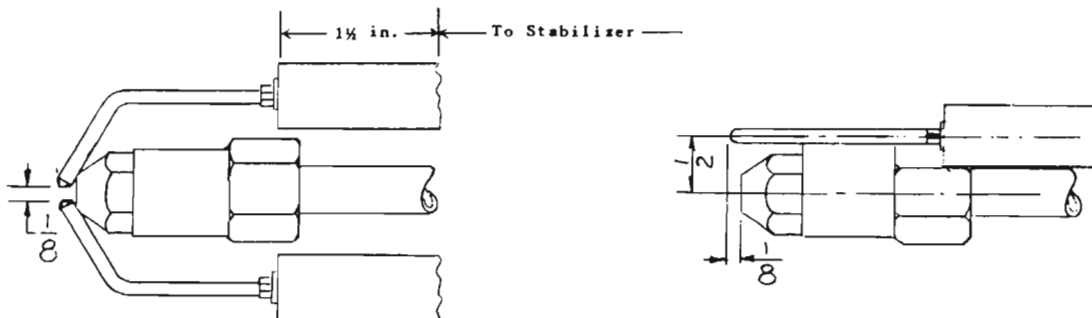

Gun Assembly Adjustment. The gun assembly can be adjusted in the slot in side of fan housing by loosening screw holding slot cover in position. Nozzle tip should ordinarily be located 5/8 inch behind the front face of the air cone. One-half inch forward adjustment is provided for use on larger rating when necessary.

Air Adjustment. The air intake is located on the left side of the blower housing and consists of two interlocking bands. To adjust, loosen screw in outer band and position band by rotating to the desired opening. Retighten screw after adjustment to assure permanent adjustment.

Sufficient air should be introduced into the fire until flame has a dark orange color. The screws should then be locked in position. After this has been set, check the top of the chimney on the outside. There should be a very slight haze, not smoke, coming out of the same. On a cold stack in extreme cold weather a white haze may come out of the chimney. This is due to the chilling of the gases and will correct itself as the chimney warms up. Any type of automatic fuel being burned in extreme cold weather will bring about the same chimney condition.

FUEL UNIT: See separate instruction sheet packed with burner.

MOTOR: Motor should be oiled at time of installation and twice during each heating season.

CHECKING INSTALLATION

After the installation has been completed and tank filled with oil, the piping should be checked for leaks. It is imperative that any indication of leaks be corrected, as an oil leak will give the house an unpleasant odor.

Adjustments made on the burner from the preceding paragraphs should be rechecked. Positive assurance must be made that the ignition and safety timing are working properly. The thermostat and furnacestat or boiler control should be checked for accuracy. Check the heating plant for leaks.

BURNER RECHECK

It is recommended that each installer make a practice of following up each installation after a period of two or three weeks for a through inspection and check to be sure the controls are properly set and working properly, that the burner is properly adjusted to a good CO₂ in the flue gases and that there are no oil leaks and that the fuel unit is set at 100 P.S.I. and nozzle cut-off is sharp, and electrodes properly set and are not collecting carbon or oil deposits, and that the nozzle is delivering a finely atomized well-shaped oil spray and is not causing electrode trouble by kicking back on the electrodes when cutting off. This kick-back of a faulty nozzle can be the source of trouble later on if not corrected. All defective nozzles should be discarded and new ones used unless you have proper facilities for reconditioning them.

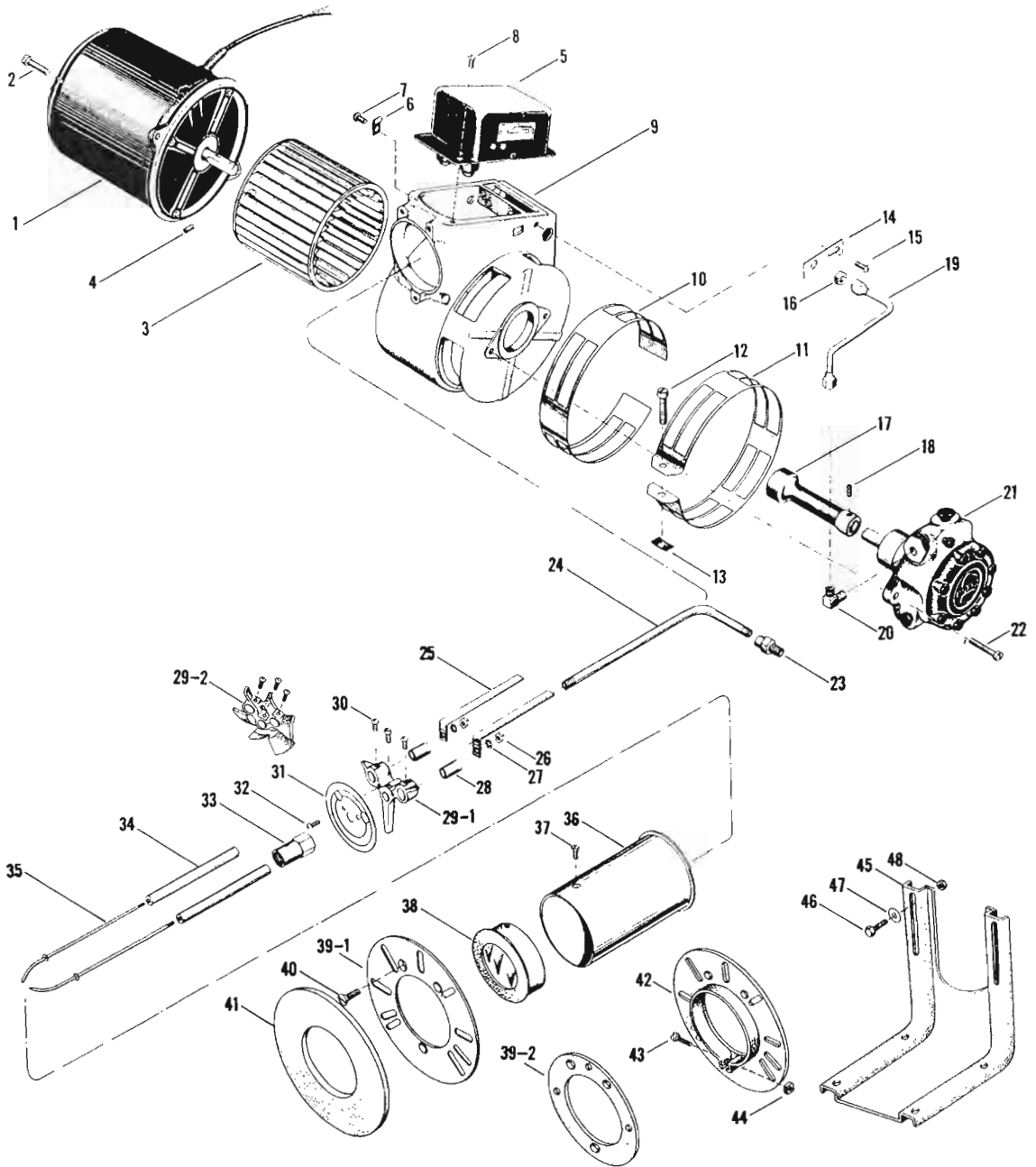

FORM NO. E

PARTS LIST

May 15, 1957
April 15, 1960 - Rev. #1

ITEM NO.	DESCRIPTION	PART NO.	ITEM NO.	DESCRIPTION	PART NO.
1	Motor, 1/8 HP, 115V, 1 Ph., 60 Cy., 1800 RPM	2667	22	Fuel Unit Mt'g. Fil.Hd.Mach.Screw, 5/16-18 x 1	12701
2	Motor Mt'g. Fil.Hd.Mach.Screw, 5/16-18 x 1	12701	23	Oil Line Fitting	12335
3	Fan, 6-5/16 Dia. x 3-3/4	2674	24	Oil Pipe - 4-1/2 Air Tube Length	12489
	Fan, 5-1/16 Dia. x 3-3/4	2706		Oil Pipe - 4-3/4 Air Tube Length	12603
4	Fan Set Screw, 5/16-18 x 5/16			Oil Pipe - 5 Air Tube Length	12417
5	Transformer, 115V, 1 Ph., 60 Cycle	2764		Oil Pipe - 5-1/4 Air Tube Length	12553
6	Hinge Clip (Die Cast Fan Housing)	12658		Oil Pipe - 5-1/2 Air Tube Length	12568
7	Hinge Clip (Sand Cast Fan Housing)	12351		Oil Pipe - 5-3/4 Air Tube Length	12724
8	Self Tapping Screw, 1/4-20 x 3/8	12698		Oil Pipe - 5-7/8 Air Tube Length	12811
9	Rd. Hd. Screw, #10-24 x 5/16			Oil Pipe - 6 Air Tube Length	12334
	Fan Housing - Cast Aluminum	4277		Oil Pipe - 6-1/4 Air Tube Length	12812
	Fan Housing - Die Cast Aluminum	4556		Oil Pipe - 6-1/2 Air Tube Length	12456
10	Air Adj. Band - Inner	2669		Oil Pipe - 6-5/8 Air Tube Length	12619
11	Air Adj. Band - Outer	2668		Oil Pipe - 7 Air Tube Length	12536
12	Air Band Fil. Hd. Mach. Screw, 5/16-18 x 1	12701		Oil Pipe - 7-1/4 Air Tube Length	12595
13	Tinnerman Speed Nut, 5/16	12343		Oil Pipe - 7-1/2 Air Tube Length	12457
14	Oil Line Adj. Slot Cover	12338		Oil Pipe - 7-5/8 Air Tube Length	12834
15	Oil Line Slot Cover Screw, #10-24 x 5/16	12697		Oil Pipe - 7-3/4 Air Tube Length	12642
16	Oil Line Locknut	12342		Oil Pipe - 8 Air Tube Length	12346
17	Pump Coupling	12341		Oil Pipe - 8-1/8 Air Tube Length	12813
18	Pump Coupling Set Screw, 1/4-20 x 5/16			Oil Pipe - 8-3/8 Air Tube Length	12725
19	Oil Line Assembly-Sundstrand, 1 Stage	12323		Oil Pipe - 8-1/2 Air Tube Length	12801
	Oil Line Assembly-Sundstrand, 2 Stage	12378		Oil Pipe - 8-5/8 Air Tube Length	12804
	Oil Line Assembly-Webster, 1 Stage	12703		Oil Pipe - 8-3/4 Air Tube Length	12604
	Oil Line Assembly-Webster, 2 Stage	12703		Oil Pipe - 9 Air Tube Length	12602
20	Oil Line Elbow	12091		Oil Pipe - 9-1/8 Air Tube Length	12805
21	Fuel Unit - Sundstrand, 1 Stage	12336		Oil Pipe - 10 Air Tube Length	12348
	Fuel Unit - Sundstrand, 2 Stage	12358		Oil Pipe - 10-1/4 Air Tube Length	12650
	Fuel Unit - Webster, 1 Stage	12662		Oil Pipe - 11 Air Tube Length	12498
	Fuel Unit - Webster, 2 Stage	12663		Oil Pipe - 11-1/4 Air Tube Length	12661

DIRECTIONS FOR THE OPERATION AND CARE OF OIL BURNER

Read Instructions Carefully and Hang This Card Near Burner for Future Reference

(A) TO START BURNER:

1. Check for oil in the storage tank.
2. Fuses in the main switch must be good.
3. Have oil burner switch open.
4. Set room thermostat about 10 degrees higher than room temperature to make sure the thermostat contacts are made. Limit control must be set high enough to make contact also.
5. Oil valve at the tank should be open and the check valve in return line properly installed so oil can return to tank.
6. Be sure nozzle of proper size for heater is in the adapter and tightly screwed down, and that the electrodes are properly spaced (See Manual). With heating plant door open, close the burner switch; and if wiring is properly done and all controls properly installed and adjusted, the burner should start. If not, check primary relay first to be sure it is properly set; and if burner does not start, recheck wiring and all controls thoroughly.
7. If burner is installed with a single oil line, the fuel unit will have to be purged of the entrapped air in the oil lines and fuel unit before the oil will flow to the nozzle (See fuel unit instruction sheet for this operation). If a return line is used, purging will not be necessary, although this will speed the starting of the burner if done. If this is done, the pump should pick up its oil in less than a minute (which is the setting for the lockout switch in the primary control). If ignition does not take place during this time, check the nozzle and electrodes.

STARTING BURNER AFTER IGNITION FAILURE.

1. Do not attempt to restart burner when excess oil has accumulated, when heating unit is full of vapors, or when the combustion chamber is very hot.
2. Press reset button on primary control and burner should start. Do not attempt this more than twice. If burner fails to operate call serviceman.

(B) FUEL OIL SPECIFICATIONS:

1. This burner is approved for oil not heavier than No. 2. The commercial standards for this oil are: Flash 110°

minimum or less; Maximum 230°F; Pour point 20°F; Water and sediment not more than 0.1%; Distillation temperature 500°F minimum and 575°F maximum at 90% of recovery. Viscosity at 100°F Saybolt Universal of 40 seconds maximum.

DO NOT USE GASOLINE, CRANKCASE OIL, OR ANY OIL CONTAINING GASOLINE.

(C) LUBRICATION:

1. The two oil cups on the oil burner motor should be lubricated every three months with a few drops of good grade light motor oil, No. 10 or 20 S.A.E.

(D) AT THE END OF THE HEATING SEASON:

1. Shut off electric current to burner at oil burner switch.
2. If oil strainer has not been cleaned recently, it should be removed and cleaned (consult instructions card furnished with fuel unit).
3. Oil storage tank should be kept filled to prevent water vapor from collecting. It is suggested the valve in the suction line be closed and oil burner switch opened. Oil storage tank should be cleaned every 2 or 3 years to remove any sediment or water that has collected in the tank. Your Fuel Oil Dealer has the equipment to do this.

(E) AT THE START OF THE HEATING SEASON:

1. It is advisable to have the Dealer inspect and service your burner for the coming heating season.
2. Heating plant, smoke pipe and chimney should be cleaned and checked for repairs.
3. Lubricate burner as directed under "C" above.
4. It is advisable to have the entire electrical system inspected before putting the burner into operation after it has been standing idle for the summer months. This should include primary relay, limit control, thermostat (clean dust from contact points), and check the electrodes for carbon and cracks in insulators, and corrosion on all terminals of the electrodes and transformer.

(F) EMERGENCY STOPS:

1. CUT OFF ALL CURRENT TO THE BURNER BY MOVING LEVER ON THE OIL BURNER ELECTRIC SWITCH TO THE "OFF" POSITION.

CAUTION

1. Check the gauge in oil storage tank periodically. Keep tank filled.
2. Don't attempt to burn garbage or refuse in your heating unit.
3. Don't fill storage tank while burner is operating.
4. Don't start burner if there is oil or vapor in the heating unit.
5. Don't attempt to burn crankcase drainings or crude oil.
6. DON'T TAMPER WITH BURNER OR CONTROLS - CALL YOUR SERVICEMAN.

DEALER

Day Phone

Night Phone.....

Burner Serial No

Date installed

BE SURE TO GIVE US SERIAL NUMBER OF BURNER WHEN ORDERING REPAIR PARTS