

# 5401116-REV M



**US Patent 6,904,800**  
**Other patents pending**

Contact Ratings			
Voltage	Motor Switch Rating		Pilot Rating
	Full Load	Locked Rotor	
24 VAC	-	-	50 VA
120 VAC	7.5 A	43.2 A	125 VA
240 VAC	3.75 A	21.6 A	50 or 60 Hz

**Listings/Approvals:**

- UL GUIDE (MBPR) for Limit Controls per UL Standard 353 Limit Controls
- UL GUIDE (MCUR2) for Electrode Assemblies - Component
- CUL per CSA Standard C22.2 No. 24-93 for temperature indicating and regulating equipment

**Probe Fitting Thread:** 3/4" NPT Brass

**Enclosure:**

NEMA Type 1 (For indoor use only.) Formed sheet metal with powder coat/plated finish. Four openings for 1/2" conduit fittings.

**Maximum Pressures:**

- Steam - 250 psi (17.6kg/cm<sup>2</sup>)
- Hot Water - 250 psi (17.6kg/cm<sup>2</sup>)

**Maximum Probe Temperature:** 250° F (121° C)

**Probe Sensitivity:** Adjustable 7K - 12K Ohms

**Input Supply Voltage:**

- LNA120xx: 120VAC
- LNA024xx: 24VAC to be supplied by an **EXTERNAL** Class 2 power source.

**Control Power Consumption:**

- 2.8VA at 120VAC
- 2.8VA at 24VAC

**GENERAL**

The LWCO is a control device to detect the presence of a conductive fluid in a vessel or tank. The electronic circuitry of the LWCO is primarily designed for use in low-pressure steam and hot water boilers not requiring manual reset or test features, to *cut off* the burner in low water level condition. (See each boiler manufacturers' specifications for recommended minimum safe levels.) The LWCO may also be used

as a secondary low water cutoff on low-pressure steam boilers. The LWCO is an automatic reset device which resumes operation after a power outage. A red LED will indicate the low water condition. The LWCO control may be used with an alarm or automatic water feeder to keep the boiler filled to the proper level. The LWCO will not lock out upon power loss provided water covers the probe.

**⚠ WARNING**

- Installation must be performed by qualified personnel and in accordance with all national and local codes and ordinances.
- Read all instructions carefully and understand them before starting installation. Save instructions for future use.
- Instruct user how to test and operate this cutoff device as described in these instructions.
- Shock Hazard. Disconnect power source before servicing. Serious injury or death could result
- Risk of explosion. Not for use in hazardous locations. Serious injury or death could result.
- The LWCO device must be installed in series ahead of other limit and operating controls installed on the boiler. When installations are complete, check for correct operation of ALL limit and operating controls.
- Wire insulation must be rated at 167° F (75° C) or greater, over copper conductors only. Use of other wire or insulation types could result in fire causing property damage, serious injury, and death.
- Foam in boiler or piping can cause improper operation. If the boiler is foaming, shutdown the boiler and clean it per the manufacturer's recommendations to eliminate foaming. Failure to do so could result in damage to the equipment and property or could cause an explosion resulting in serious injury or death.
- Hot or pressurized boiler systems can discharge steam and hot water. Cool boiler system to 80° F (27° C) and to 0 psi (0 Bar) before servicing. Failure to do so could result in serious burns.

## ⚠ CAUTION

- Do not tighten by grasping the device enclosure. Use wrenching flats on the probe bushing only. Failure to install properly could damage the device and cause improper operation resulting in damage to equipment and property.
- Do not use manual reset low water cutoffs with automatic water feeders. Flooding, equipment damage, and property damage can result. Only use automatic water feeders with automatic reset low water cutoffs.

### PROBE SPACING REQUIREMENTS

FIG. 1

## ⚠ CAUTION

Do not mount device with probe angled upward or deposits can accumulate in the probe. Mount only with probe facing horizontally or vertically downward and maintain 1/4" clearance from electrode. Failure to install probe as directed can cause improper operation and damage to equipment and property.

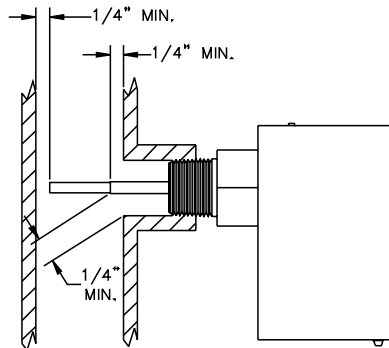

DWG. #1108-1

### CONTROL UNIT MOUNTED ON PROBE

FIG. 2

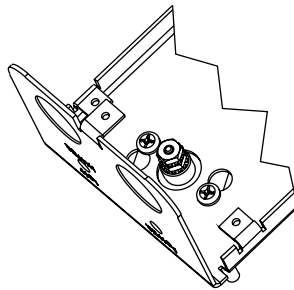

DWG. #1108-2

### LWCO

FIG. 3

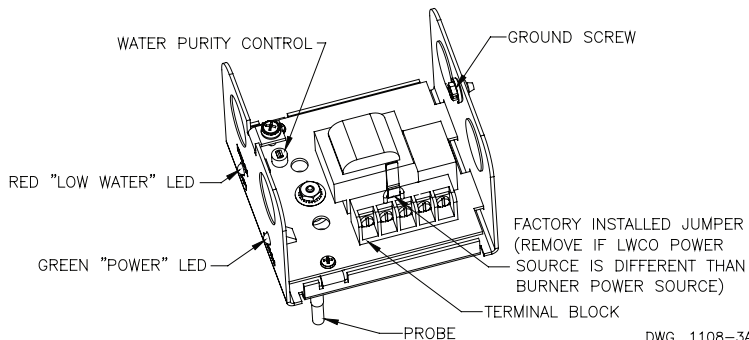

DWG. 1108-3A

### INSTALLATION

#### IMPORTANT NOTES FOR PROBE INSTALLATION:

## ⚠ CAUTION

Use pipe thread sealant only for sealing probe threads. Do not use teflon tape. Use of teflon tape can insulate probe electrically and can cause improper device operation and damage to equipment or property.

1. Be sure the probe is installed above the **minimum safe** water level, as previously determined from the boiler manufacturer's literature.
2. Be sure the probe extends into the boiler cavity so that contact with the water is made.
3. Be sure the exposed portion of the stainless steel probe is a *minimum*

of 1/4" from any grounding surface inside the boiler to prevent the probe from shorting (see Fig 1).

#### Control Unit Mounting onto Probe (See Fig. 2):

1. Tighten the probe into the tapped location of the boiler with a wrench, using the bushing flats provided.
2. Make sure the heads of the two mounting screws in the probe bushing are loosened approximately 1/8" from the bushing surface.
3. Then remove the first lock washer/nut from the probe threads.
4. Orient the slotted holes in the control unit over the heads of the mounting screws of the probe and turn control unit counter-clockwise so that the ends of the slots are fully under the mounting screw heads. Tighten mounting screws.
5. Replace the lock washer/nut onto probe and tighten.

**LWCO OUTLINE DWG.  
FIG. 4**

(4)  $\varnothing$ .886 ELECTRICAL KNOCKOUTS FOR 1/2" CONDUIT CONNECTION

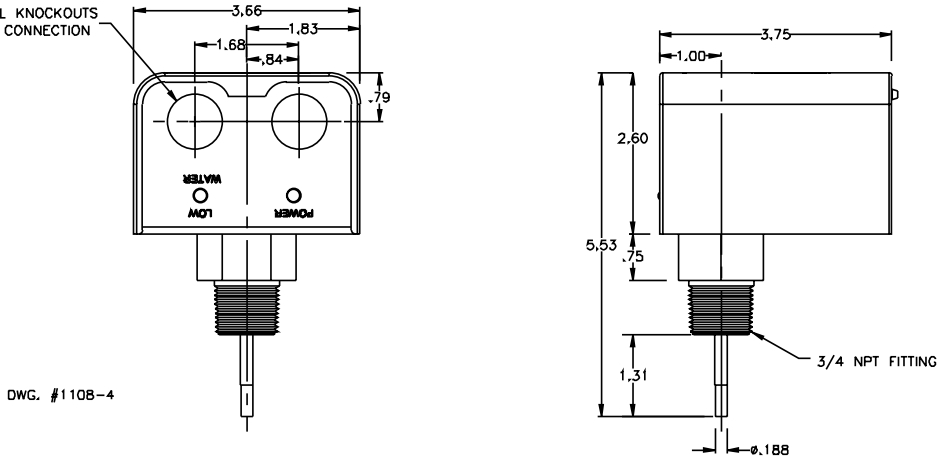

DWG. #1108-4

**LWCO WIRING DIAGRAM USING BURNER CIRCUIT POWER SOURCE  
FIG. 5**

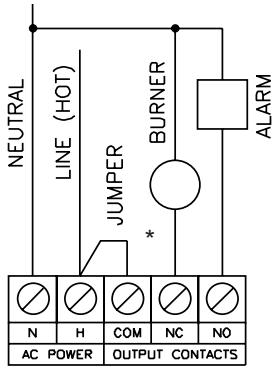

DWG. #1108-5

\*Factory Installed

**LWCO WIRING DIAGRAM USING POWER SOURCE OTHER THAN BURNER CIRCUIT  
FIG. 6**

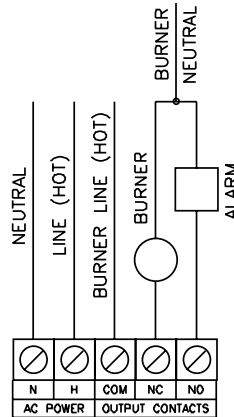

DWG. #1108-6

**TERMINAL BLOCK CONNECTIONS CLAMPING PLATE TERMINAL  
FIG. 7**

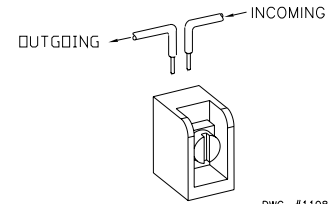

DWG. #1108-10

**CAUTION**

Wire insulation must be rated at 167° F (75° C) or greater. Use at least 18 AWG copper conductors, or as required by code. Use of other wire or insulation types could result in fire causing property damage or serious injury.

**NOTE:** For 24 VAC models, LNA024xx, 24 VAC to be supplied by an **EXTERNAL** Class 2 power source to terminals H and N. For 120 VAC models, LNA120xx, 120 VAC is supplied by an external circuit to terminals H and N.

**LWCO Wiring Using the Burner Circuit Power Source (See Fig. 5):**

1. Connect the hot lead wire from the power source to terminal **H**.
2. Connect the neutral lead wire from the power source to terminal **N**.
3. Verify that factory installed jumper is present or connect an 18 AWG (min.) jumper wire from terminal **H** to terminal **COM**.

**CAUTION**

Be sure the power source for Control Unit and burner circuit are the same voltage. Make sure you are not introducing a second voltage source into the burner circuit via the jumper. This will bypass other operating limit, and/or safety controls, which may result in property damage, personal injury, or death.

4. Connect the neutral wire of the power source to the neutral side of the burner circuit. Connect wire from the hot side of the burner circuit to terminal **NC**.

5. Connect the neutral wire of the power source to the neutral side of a water feeder or alarm. Connect wire from the hot side of the water feeder or alarm to terminal **NO**.

**LWCO Wiring Using a Power Source Other than Burner Circuit (See Fig. 6):**

1. **Remove Factory installed jumper.**
2. Connect the hot lead wire from the separate power source to terminal **H**.
3. Connect the neutral lead wire from the separate power source to terminal **N**.
4. Connect the hot lead wire from the burner circuit power source to terminal **COM**.
5. Connect the neutral wire of the burner circuit power source to the neutral side of the burner circuit. Connect wire from the hot side of the burner circuit to terminal **NC**.
6. Connect the neutral wire of the burner circuit power source to the neutral side of a water feeder or alarm. Connect wire from the hot side of the water feeder or alarm to terminal **NO**.

### Test For Proper Function:

- DO NOT fill boiler. Turn on electric power to the boiler and set the thermostat.  
On initial start-up the LWCO will indicate low water condition, which indicates proper function. The burner **should not** operate without water in the system. The red LED on the Control Unit should be illuminated.
- Fill boiler with water.  
Once water covers the probe, the red LED on the Control Unit should turn off and the burner should ignite. If the red LED does not turn off, the water level may still be below the level of the Probe or the water may be too "Pure" (low conductivity). See Water Purity Adjustment section.
- Once correct operation of the LWCO has been tested, then test **ALL** other safety, limit and control devices before finalizing system operation.

**Water Purity Control Adjustments:** If testing indicates proper operation, no adjustment is required.

- Verify that water covers the probe.
- Slowly turn the water purity control, **RV1**, on the PC Board toward the "+" setting with a small screwdriver until the red LED turns off (see FIG. 3).
- Once the red LED turns off, leave the water purity control in that position.
- If adjustment to the maximum "+" setting does not cause the red LED to turn off, the water is too pure and must be treated.

## ⚠ CAUTION

Use care when adjusting the Water Purity Control. Damaging the adjustment can cause the device to always signal a low water condition and prevents proper operation. Permanent damage to the equipment can result.

### Troubleshooting:

If the LWCO fails to function normally, perform the following steps to verify the proper installation:

- Make sure the water level covers the probe.
- Verify **ALL** LWCO wiring.
- If teflon tape was used on the threads of the brass bushing for the probe, remove the tape and install with a small amount of pipe sealant.
- Adjust the water purity control as indicated in the Water Purity Control Adjustment section.
- Water treatment may be required.
- If water covers the probe and the LWCO still indicates a low

water condition, the probe may be coated with flux or oils. Clean per boiler manufacturer's recommendations or add a mixture of Trisodium Phosphate and water. Heat and circulate this solution for at least one hour. Drain and completely flush system with clean water. Remove probe and thoroughly clean all wetted surfaces with a scouring pad or steel wool. Refill system and test for proper function.

### Cleaning and Replacement:

Probe must be inspected annually for scale build-up. Clean all scale from probe and teflon sleeve taking care not to damage the teflon sleeve (see Fig 8). Probe should be replaced every 10 years. Replace more often if used in areas where heavy water treatment is required, when cleaning is needed more frequent than annually, and/or boiler demands for make-up water are high.

The Control Unit should be replaced every 15 years. In areas of high humidity and heavy dust or other airborne contaminants more frequent replacement may be required.

### PROBE CLEANING

FIG. 8

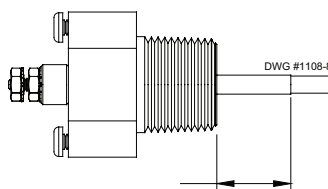

TEFLON SLEEVE INSULATOR  
(Be careful not to damage during cleaning)

### LN WIRING CROSS REFERENCE

Manufacturer	Device or Series	Power Connections		Output Contacts		
		Hot	Neutral	Common	To Burner	To Water Feeder / Alarm
Taco	LN Series	H	N	COM	NC	NO
McDonnell & Miller	PS-801/851 (Older Models w/Red & Amber LEDs)	1	2	3	5	4
McDonnell & Miller	PS-801/851 (New Models w/Red & Green LEDs)	H	N	C	B	W
McDonnell & Miller	PS-802/852 (Older Models w/Red & Amber LEDs)	H	N	C	B	W
McDonnell & Miller	PS-802/852 (New Models w/Red & Green LEDs)	H	N	C	B	W
McDonnell & Miller	Series 750	1	2	3	4	5
McDonnell & Miller	RB - 122	H (Black Wire)	N (White Wire)	C (Yellow Wire)	B (Yellow Wire)	-
McDonnell & Miller	RB - 120	1	2	3	4	5
McDonnell & Miller	RB - 24	Red Wire	White Wire	Yellow Wire	Yellow Wire	-
Hydrolevel	24	Black Wire	White Wire	-	Orange Wire	Brown Wire
Hydrolevel	170	H	GN	P1	P2	A
Hydrolevel	400, 500, 600, 700, 450, 550, 650, 750	1	2	P1	P2	A
Honeywell	RW700 Series (Except RW700A1098)	L1	L2	-	B	A
Honeywell	RW700A1098	T1	T2	-	B	A

### LWCO Ordering

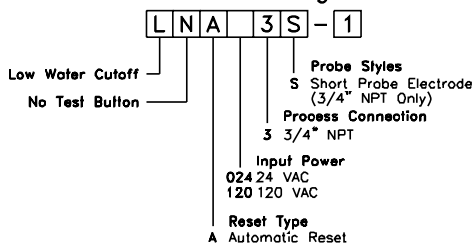

### Control Only Ordering

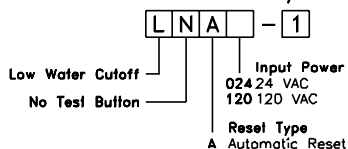

### Probe Only Ordering

