

Chapter 12

LIMIT CONTROLS & THERMOSTATS

CLICK ANYWHERE on THIS PAGE to RETURN to FAN
LIMIT SWITCH INSTALLATION & WIRING at
InspectApedia.com

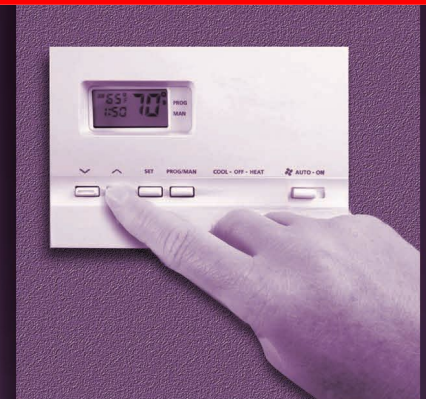

IN THIS CHAPTER

- The oil-fired heating system control circuit
- Thermostats, principles and design, low voltage and line voltage types and heat anticipators
- Limit controls, warm air fan limits and electronic fan timer center, steam pressure controls and low-water cutoffs, as well as hot water heating aquastats



SET

PROG/MAN

COOL - OFF - HEAT



AUTO - ON



BATTERY POWER



Chapter 12

Limit Controls and Thermostats

There are a large variety of limit controls, thermostats, and switching relays used in oil-fired heating systems. At first glance, it can be confusing. Remember, these devices are just switches that turn things on and off.

Some of these switches are turned on and off by the warping or flexing action of bimetal blades. Some use magnets and springs. Some are controlled by a fluid that expands and contracts quickly. Some are line voltage and some are low voltage. Some need transformers to change the voltage so that low voltage switches can control line voltage loads. Some controls now use solid-state microprocessors and other electronic devices.

No matter what they look like, limit controls are just switches. You may want to review the section on switches in the basic electricity chapter before you go any further.

Electrical control circuit

The hot (L1) electric power wire for the basic oilburner circuit begins at the service panel fuse, or circuit breaker, travels to the main switch, then to a junction box that is usually located on the ceiling near the burner. Many states and local codes require a thermal or Firomatic® switch at this junction box. From the junction box, the hot line (which is a black wire) runs to the serviceman's switch, through the high limit

Figure 12-1: Basic oil burner control circuit

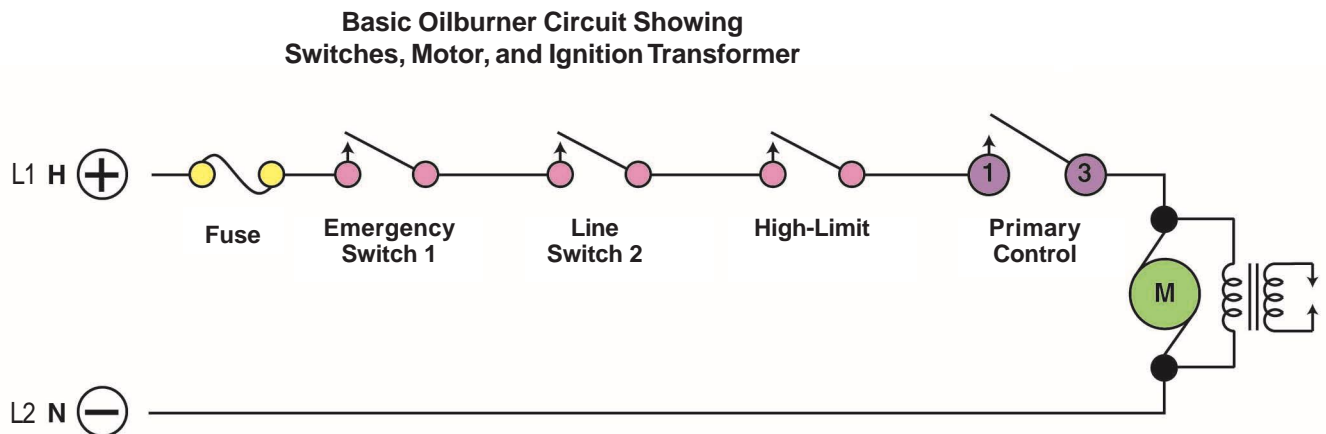

control and then to terminal #1 or the black lead wire of the primary control. From the primary control, wires are connected to the oilburner motor and ignition transformer. All wires up to this point carry 120 volt line voltage.

The neutral white (L2) wire of the control circuit also starts at the main entrance service panel, and passes to terminal #2 or the white lead of the primary control. On a modern circuit, there should never be any switches or fuses in the neutral side of the circuit. Older homes with knob and tubing wiring often have fuses on both the hot side and the neutral side of the circuit. And sometimes switches, limits, and fuses are put on both sides by mistake. Never assume anything when it comes to electricity. Always test! Also, before doing any wiring, check with

the local fire marshal or other authority to make sure that your installation complies with all local requirements. In some areas, only licensed electricians are allowed to install line voltage wiring.

The low voltage (24 volt) side of the oilburner control circuit usually starts at the step down transformer in the primary control. The low voltage circuit turns the burner, circulator, or blower on and off, and opens and closes valves in response to temperature changes in the heated space and the appliance.

See Figures 12-1 and 12-2.

Burner switch

The burner switch is used to shut off the burner in an emergency or as a convenience switch when servicing the oilburner. There

Figure 12-2:
Circuit wiring

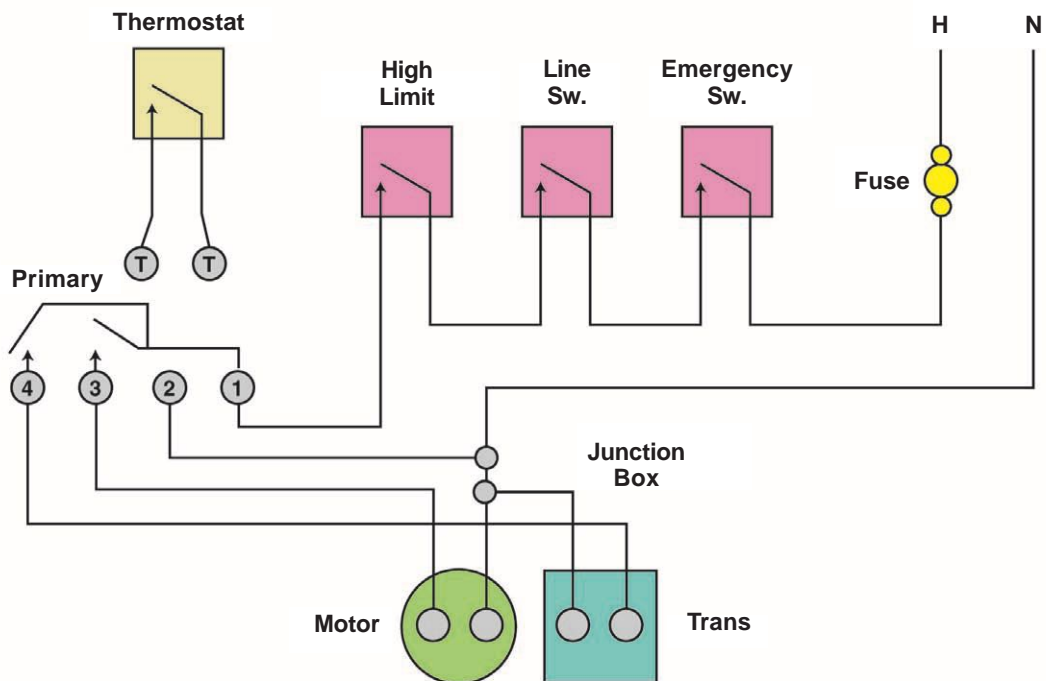

are usually two disconnect switches. The first is called a customer or emergency switch and it is normally located at the head of the basement stairs or at the entrance to the heater room. The second switch is a serviceman's switch and may include a fuse. This switch is located on or near the furnace or boiler.

Thermostats

Principles and design

A thermostat is a mechanical or electronic switch that automatically opens or closes a circuit as room temperature changes. The thermostat's purpose is to start the burner and/or circulator or blower when the temperature is below the established setting, and to shut them off when the heat demand is satisfied. Thermostats must be extremely sensitive to temperature changes. In older thermostats, a bimetal element warps or unwinds in response to temperature change to open or close a switch. In the solid-state thermostat, the room temperature changes the resistance of an electronic device that will act in various methods to open and close circuits.

The majority of thermostats installed in the field still use a bimetal element and mercury switch to function. The following text covers this type of thermostat, Figure 12-3 shows the most common type in use. The replacements are mostly electronic and will be discussed later.

The bimetallic element comprises two dissimilar metal strips, bonded together, which expand or contract with a change in temperature at different rates of speed. This difference in expansion

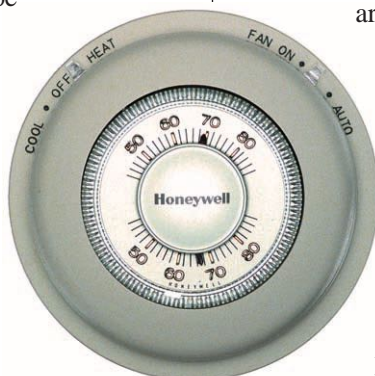

Figure 12-3

rate will cause the bonded bimetallic element to bend or warp with temperature changes. By bending or moving when heat is applied to it or taken away, it creates a mechanical force that flips a mercury switch to make or break a pair of switch contacts. Making or breaking a contact means closing or opening a circuit. Remember, as with all mercury switches, such thermostats must be installed level. Figure 12-4 shows how to level the T87 thermostat.

3 wire thermostats vs. 2 wire thermostats

Very old style thermostats needed three wires to operate. When replacing an old three wire thermostat with a new two wire, eliminate the red wire. Today there are some three wire thermostats that operate some zone valve motors and dampers. A circuit is necessary to drive the valve or damper open and another circuit must drive it closed. The switching action of these thermostats is single pole, double throw as opposed to a single pole, single throw switch for the two wire circuits. Thermostats of this type are never connected to primary controls.

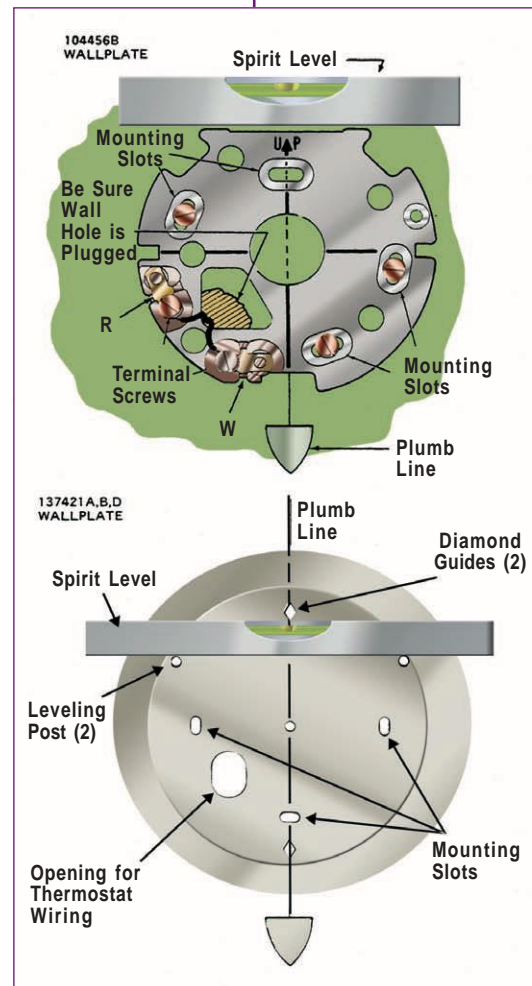

Figure 12-4:
T-87 thermostat

Low voltage and line voltage thermostats

In some older systems, line voltage thermostats were used to directly control the circulator without the use of a switching relay. Line voltage thermostats are not as sensitive as low voltage types and this often leads to wide fluctuations in the room temperature. If open blade contacts are used in the line voltage controller, the contacts will eventually burn, and pitting of the contacts is the result. At this point we can lose control of the room temperature. Line voltage thermostats are mostly used in commercial and industrial applications.

Heat anticipating principle

The differential of a thermostat is the number of degrees temperature change that are required to cause its bimetal or bellows to move the required distance to close or open its electrical contacts. The number of degrees difference between the opening and closing of a thermostat is called the mechanical differential. For example, if a thermostat opened at 70°F, and its contacts closed at 68°F, its mechanical differential would be 2°.

Manufacturers incorporate an anticipat-

ing heater to increase the sensitivity of the thermostat. It reduces the mechanical differential. The heat anticipator is a small electrical resistance heater that fools the thermostat into thinking it is warmer in the room than it actually is.

The heater is wired so that electric current flows through it when the thermostat calls for heat. The anticipator heater creates heat within the thermostat near the bimetallic element. This causes the thermostat to break its contacts prior to the room air reaching the temperature of the dial setting, so the burner is turned off slightly ahead of the time that the room air temperature increases to the dial setting of the thermostat. The blower in a warm air system continues to operate, bringing the room air temperature up to the dial setting. With a hot water or steam system the heat in the radiators or baseboard will raise the room temperature after the thermostat shuts off the burner and circulator.

The anticipating heater must be adjusted to match the current that is supplied to the thermostat. We must adjust for the number of amps supplied to the heater, because the greater the number of amps, the quicker the heater will heat up. Current flow in this 24 volt circuit generally varies from 0.05 amperes to 0.6 amperes, depending on the make and model of control. When setting the heat anticipator, consider the length of the wire and other resistances in the circuit. The current from the control to the thermostat heater circuit should be measured with an amperage meter and the anticipator set to the amps in the low voltage circuit.

If an ammeter is not available, set the anticipator to the amp rating found inside the cover of the control to which the thermostat is directly connected.

Figure 12-5 shows the location of the heat anticipator in a heating and cooling thermostat. Notice the anticipator in the R

Figure 12-5:
T-87F heat
anticipator

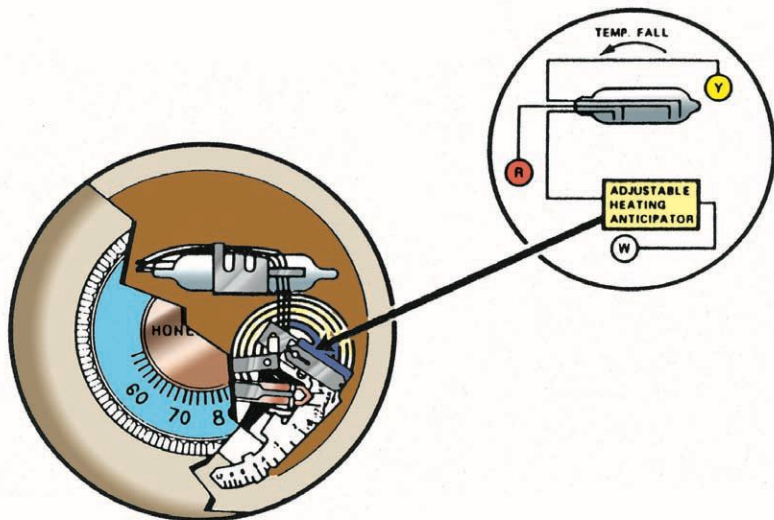

to W circuit. This is because the anticipator is only used for heating and not in the circuit R and Y that would be used if this thermostat were used for air conditioning. Figure 12-6 shows the heater indicator and the scale in a thermostat.

In some installations, longer operations may be needed to assure delivery of heat throughout the house. To lengthen operations, move the heater indicator preferably not more than half a division in the direction of the scale arrow. To shorten operations, move the indicator in the opposite direction.

If the operating control supplies 0.4 amps to the thermostat circuit and the anticipating heater of the thermostat is set at 0.8 amps, the burning cycle will be long. However, if the heat anticipator of the thermostat is set at 0.2 amps while the control is supplying .4 amps, then the burner cycle will be short. In the latter case, the burner will operate on and off for short periods of time (short cycling).

Electronic thermostats

Figure 12-7 shows some examples of electronic thermostats. These thermostats rely on solid-state technology to not only operate the equipment, but to maintain and store temperature settings, day and date, and number of cycles. Unlike the earlier mechanical thermostats that had only one day per operation cycle, many of these thermostats can have four different settings for all seven days of the week.

The difference in electronic thermostats over manual and mechanical clock types is the lack of an adjustable anticipator. Instead the electronic thermostat must be programmed according to 'cycle rate adjustment'. Once these settings are made at the time of installation, the thermostat, and its circuitry accommodate for the correct number of cycles.

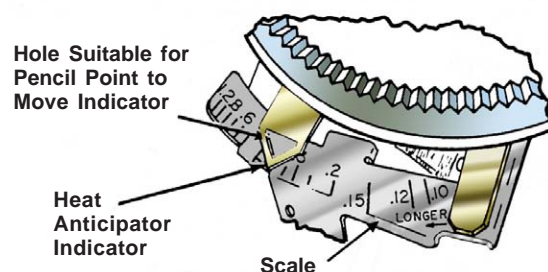

Figure 12-6:
T-87F heater
adjustment

Location of the thermostat

A thermostat should be installed about 5 feet from the floor on an inside living or dining room wall, or a wall where there is good natural air circulation. It may be wise to select several good locations, pointing them out to the homeowner, and then let them choose from the suggested locations.

Some locations that will cause trouble are:

1. Above a TV, stereo, computer, or lamp
2. On or near an outside wall
3. Near a radiator or air register
4. In line with the air stream from a register
5. On a wall containing steam pipes, hot water pipes, warm air risers, or chimneys
6. On a wall with high internal air movement
7. Behind a door or other obstruction to free air circulation
8. In an over radiated or under radiated room
9. Near a window or door frequently opened to the outside
10. In a room with a heat source such as refrigerator, stove, or fireplace
11. On a wall or partition subject to excessive vibration

Figure 12-7:
Electronic thermostats



Mounting thermostats

- Servicing or installing a thermostat is a job for clean hands. Do not mar or soil wall surfaces.
- Be absolutely sure that all wires are connected to their proper terminals and that all connections are tight. If a color code is being used, be certain that it is followed.
- If mercury switches are used in the thermostat, be absolutely certain the thermostat back plate and/or the thermostat itself are level.
- All excess wire should be pushed back into the hole in the wall, and the hole should be plugged with putty to prevent cool air drafts from affecting the thermostat performance.

Limit controls

A limit control is a temperature or pressure actuated switch. Limit controls are generally divided into two groups: the high limit or safety controls and the low limit or operating controls. Limit controls are of either the direct acting or reverse acting type. Direct acting controls break (open) their contact on temperature rise while the reverse acting controls make (close) their contacts on temperature rise. Remember, in electricity, open means that there will be no flow of electricity and closed means electricity can flow through the switch.

The high limit is a safety device that turns off the burner should temperatures get too high within the furnace or boiler, or steam pressure become excessive in a steam boiler. This control should be line voltage, wired in series with the primary control so that it can turn off only the oilburner, never the circulator or system fan. The circulator or fan must stay on to remove the excessive heat produced. A low limit or operating control is a limit that is used to control the operation of the burner and blower or circulator.

Remember, in electricity, open means that there will be no flow of electricity and closed means electricity can flow through the switch.

Warm air limit controls

Warm air limit controls protect the furnace heat exchanger from excessively high temperatures and operate the blower. Both the high limit control and the fan control may be operated by a bimetallic element inserted in the plenum, or through an electronic control panel. The line voltage high limit control in series with the primary control may employ either metal to metal contacts or a mercury switch to make or break the circuit.

Fan and limit controls are usually combined into one housing. In this instance, the helix type bimetallic element operates both the fan control switch and the high limit control switch. Figure 12-8 shows a combination fan and limit control. A single dial as shown in Figure 12-9 (old

Figure 12-8:
Combination fan and limit control

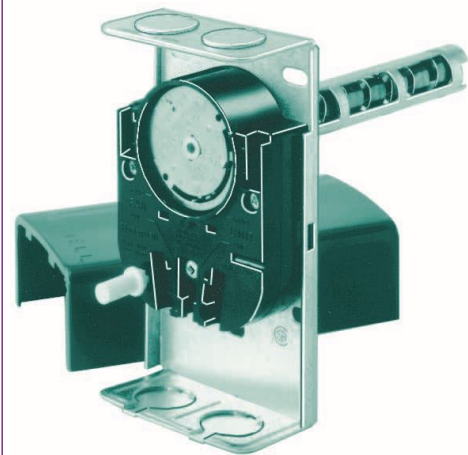

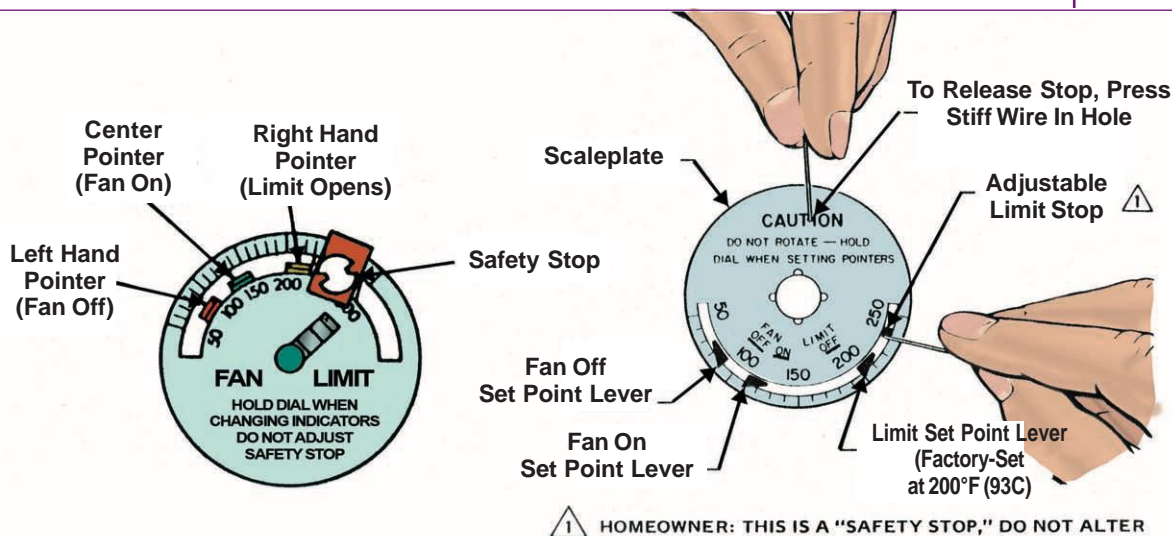

Figure 12-9:
High limit

and newer version) has indicators for the fan on position and the fan off position as well as an indicator for the high limit setting.

The function of the fan control is to operate the system blower when the air temperature is within the fan control dial settings. The fan control will permit the fan to operate when the air temperature in the furnace rises above the fan on setting as prescribed for the specific system or the manufacturer's requirements. The fan control will also prevent blower operation in the event the air temperature is below the fan off setting of the fan control. This prevents cool air from being forced into the living area during cold weather.

Many fan controls provide for manual operation to provide for summer air circulation. After the burner has been on for a short period, the element of the fan control will sense the desired amount of heat in the plenum or bonnet of the furnace, and start the blower. The blower will then run as long as there is heat, which can be for some time after the burner has stopped.

Limit terminals and fan terminals (old and new) connect the line voltage wires of the heating system electrical circuit. As shown in Figure 12-10 on following page.

The heat sensing element, or bimetallic element, expands and contracts with a change in furnace temperature. Since the element is helical in shape, it turns with a circular motion, either clockwise or counterclockwise, depending upon whether the furnace air is being heated or it is cooling off.

The operation of the fan switch control as shown in Figure 12-10 is as follows:

1. If the furnace temperature is the same as the room temperature and the fan on indicator is set at 140°F, the fan off indicator set at 110°F and the thermostat then calls for heat, the burner is turned on.
2. As the burner produces heat, the air in the furnace begins to rise in temperature and the helical element reacts to this change in temperature. In its attempt to expand, the bimetal causes the scale plate to turn in a clockwise direction. Once the scale plate

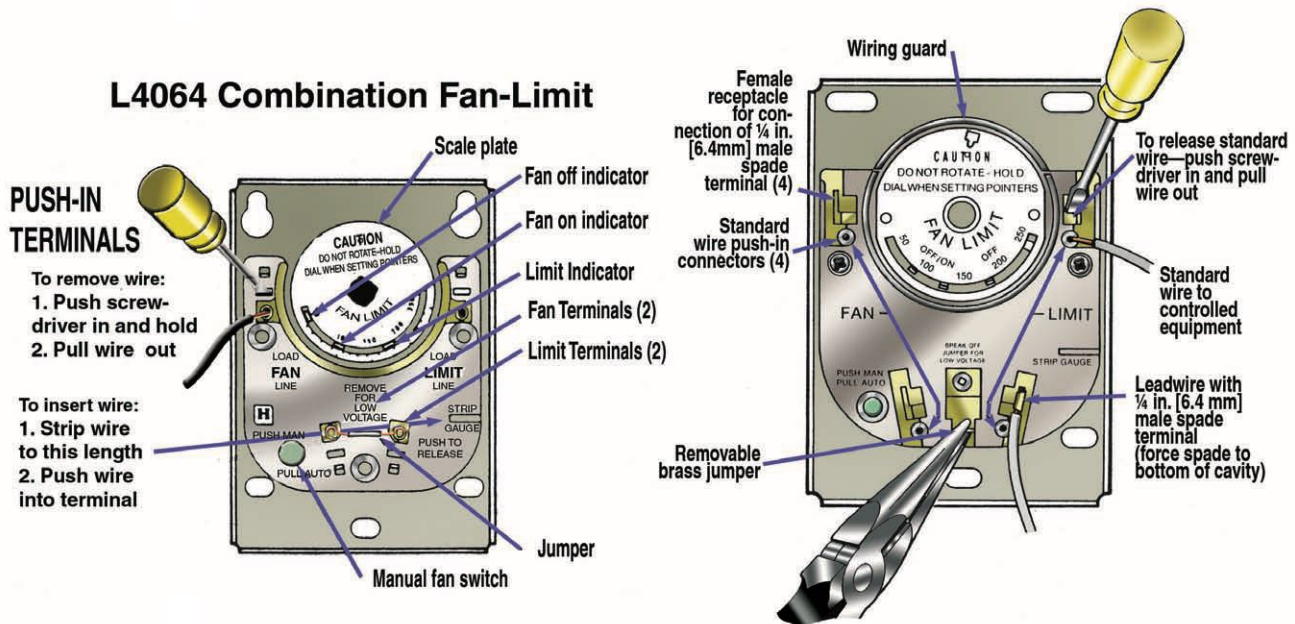

Figure 12-10:
Limit and fan
terminals

has reached the fan on position, 140°F, the fan switch will close its contacts and the fan will be turned on, forcing warm air into the living area.

3. The burner will continue to operate until the room thermostat is satisfied, at which time it will turn off. However, the fan will continue to operate until the air temperature has dropped below the minimum setting or the fan off indicator setting. Once this point has been reached, the fan control will then “open” its electrical contacts, and the fan will stop.

The heat exchanger of the furnace is still hot, although the burner, controlled by the thermostat, is not running; warm air currents will continue to rise to the bonnet. Under certain conditions this heat may be sufficient to again elevate the temperature to 140°F, and the fan switch will again operate the fan until all of this heated air is delivered to the living area.

In the event that the fan fails to operate, the air filters are clogged, or a blower belt is broken; the temperature in the furnace would continue to rise, going beyond the fan on position and ultimately reaching the high limit indicator setting of 200°F as shown in Figure 12-10.

Upon reaching this point, the limit control would open its electrical contact and prevent line voltage from reaching the primary control. This in turn would prevent line voltage from reaching the oilburner motor and ignition transformer thus causing the oilburner to go off. The high limit control would continue to hold its electrical switch contacts open until the air temperature in the bonnet had dropped below the 200°F mark minus the differential of the switch. (Normally 25°). The helical element would at the same time cool, rotating in a counterclockwise direction, causing the limit indicator to also rotate in a counterclock-

wise direction until the scale plate had traveled below 175°F. Once this point has been reached, line voltage power would once again be restored to the primary control and if the room thermostat is still calling for heat, the burner would once again operate.

Always consult local codes and ordinances or regulations and manufacturer's instructions before installing a fan limit control. The helical element of the fan limit control must be located in the furnace plenum or at a location where it will be subjected to a representative airflow and temperature. It must not be located near cold air returns or the humidifier, nor in a dead air spot where there is poor circulation. It must definitely not touch any internal parts of the furnace.

Figure 12-11 is a schematic wiring diagram showing how a Honeywell L4064B

combination control is wired into the heating system electrical circuit. In this illustration, the limit control is wired directly into the hot line of the line voltage circuit and is in series with the primary control. The high limit control should never be wired to the neutral wire of the furnace unit.

Figure 12-12 lists some typical warm air limit settings and fan control on and off settings; the lower these settings can be

Figure 12-12

Warm Air Limit Settings				
Types of Systems	Limit	Fan = On	Fan = Off	
Average furnace, average system	200°F	140°F	110°F	
Oversized furnace and/or oversized fan and/or short air ducts	170°F	130°F	90°F	
Undersized furnace and/or undersized fan and/or long air ducts	230°F	160°F	130°F	

without creating uncomfortably cool air delivery into the living area, the more economical the operation of the heating system will be.

Referring to Figure 12-11, note that the fan motor is wired into the system circuit

Figure 12-11:
Warm air circuit

Oil-Fired Forced Warm Air System Stack Detector

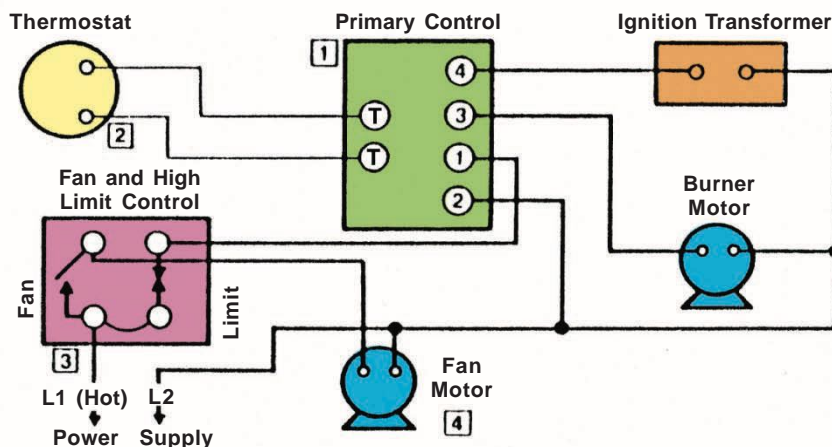

in parallel with the primary control and the high limit control. The fan control should always be connected on a warm air system in this manner to enable the fan motor to operate independently of the burner.

Electronic fan timer center

Most new warm air furnaces incorporate air conditioning, heating, humidification and air cleaning in one unit. They also feature multi-speed direct drive blower motors. To operate all these devices, they need an electronic fan center. A good example of this device is the Honeywell ST9103A Electronic Fan

Timer, Figure 12-13. It integrates the control of all burner and system fan operations in an oil furnace.

This control serves as the central wiring point for most of the electric components of the furnace. The ST9103A allows the thermostat to control heating, cooling, and system fan demands and run the oilburner primary control as well as up to a four speed circulating fan. It also monitors a limit switch string, which energizes the circulating fan whenever the limit switch opens. Electronic air cleaner and humidifier convenience

terminal connections are provided as an option. A means for operating continuous indoor air circulation is also available as an option. See Figure 12-14 for ST9103A wiring connections and Table 12-1 for the operating sequence.

Steam system controls

Pressure controls

Limit controls that respond to changes in steam pressure are called pressure controls, or *pressuretrols*. As is the case with warm air limit controls and hot water controls,

Figure 12-13:
Electronic fan timer

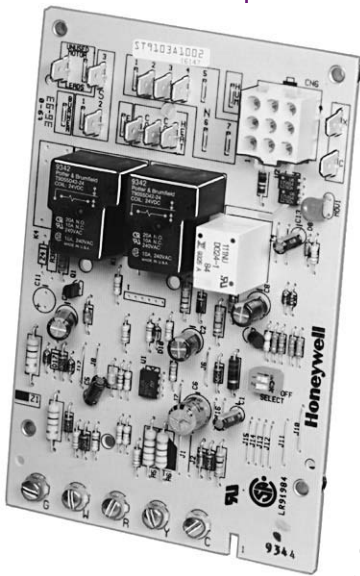

Figure 12-14:
Honeywell ST9103A
wiring connections

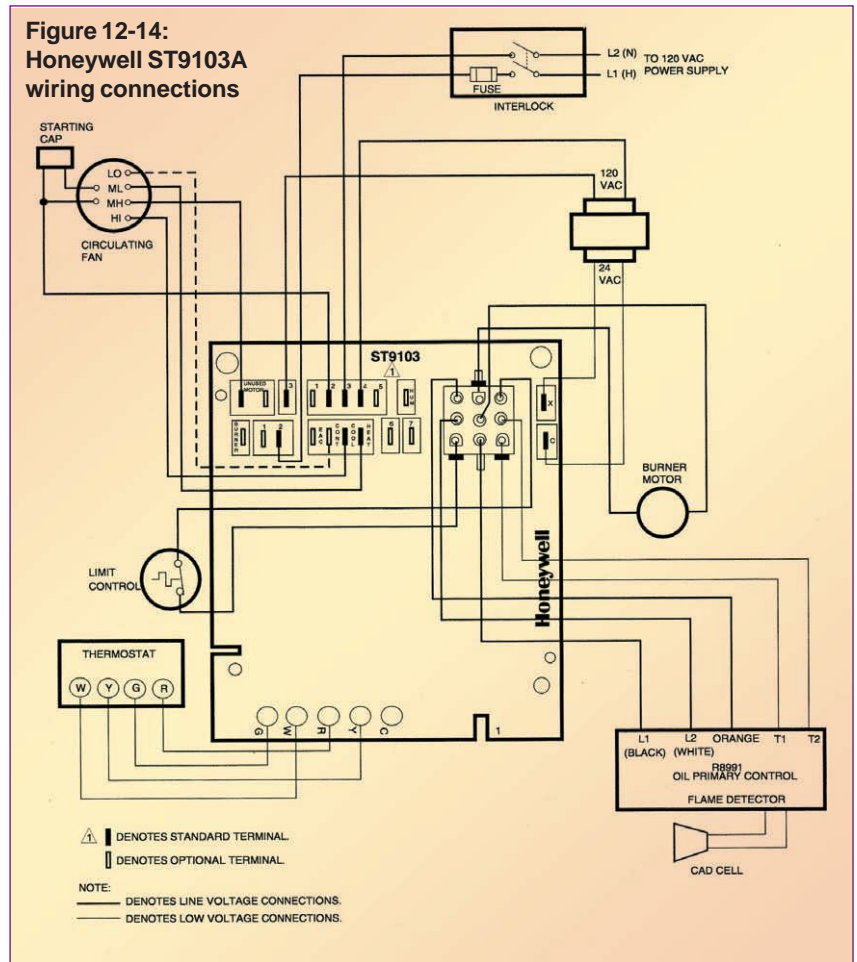

Table 12-1

Action	System Response
Thermostat calls for heat. (W terminal is energized)	<ul style="list-style-type: none"> • ST9103A closes oil primary control T-T connections. • Ignition system and oil primary control start the furnace. Oil flows as long as oil primary control senses flame. • Burner motor is energized and heat fan on delay timing begins. When timing is complete, the circulating fan is energized at heat speed and warm air is delivered to the controlled space.
Thermostat ends call for heat	<ul style="list-style-type: none"> • Oil primary control is de-energized, terminating the burner cycle. • Heat fan off delay timing begins. When timing is complete, the circulating fan is de-energized. • ST9103A returns to standby mode (oil primary control and circulating fan are off).
Burner fails to light	<ul style="list-style-type: none"> • Oil primary control locks out within lockout timing (timing depends on oil primary control). • Burner motor is de-energized. • If heat fan has started, it continues through the selected delay period.
Established flame fails	<ul style="list-style-type: none"> • Burner motor is de-energized and oil primary control goes into recycle mode. • If selected heat fan off delay is longer than the recycle delay timing, the heat fan continues to run through the next trial for ignition.
Thermostat begins call for cool (G and Y terminals are de-energized)	<ul style="list-style-type: none"> • Circulating fan is energized at cool speed. • Cooling compressor turns on immediately.
Thermostat ends call for cool (G and Y terminals are de-energized)	<ul style="list-style-type: none"> • Circulating fan and cooling compressor turn off immediately.
Thermostat begins call for fan (G terminal is energized)	<ul style="list-style-type: none"> • Circulating fan is energized immediately at cool speed. • ST9103A may be factory-configured to operate heat speed in this mode.
Thermostat ends call for fan (G terminal is de-energized)	<ul style="list-style-type: none"> • Circulating fan is de-energized.
Limit switch string opens	<ul style="list-style-type: none"> • Oil primary controls shuts off burner. • Circulating fan is energized immediately at heat speed. • ST9103A opens oil primary control T-T connections. • Circulating fan runs as long as limit string stays open. • If there is a call for cooling or fan, the circulating fan switches from heat speed to cool speed.
Limit switch string closes	<ul style="list-style-type: none"> • ST9103A begins heat fan off delay sequence. • Circulating fan turns off after the selected heat fan off delay timing. • ST9103A recloses oil primary control T-T connections. • Oil primary control is energized, initiating burner light off.
Continuous circulating fan is connected	<ul style="list-style-type: none"> • Circulating fan is energized at low speed when there is no call for heat, cool or fan. • If fan operation is required by a call for heat, cool or fan, the ST9103A switches off the continuous fan speed tap before energizing the other fan speed.
Electronic air cleaner is connected (Optional connectors are available for 120 Vac electronic air cleaner)	<ul style="list-style-type: none"> • Electronic air cleaner (EAC) connections are energized when the heat or cool speed of the circulating fan is energized. EAC connections are not energized when the optional continuous fan terminal is energized.
Humidity control connected (Optional connectors are available for 120 Vac humidifier)	<ul style="list-style-type: none"> • Humidifier connections are energized when burner motor is energized.

pressure controls will also complete or break a circuit by opening or closing their contacts. Their contacts may be constructed of the metal to metal design, or they may be of the mercury tube type. The operating range of a pressure control must never exceed the design pressure of the boiler. All residential and most commercial boilers are of the low pressure type with a maximum pressure range not to exceed 15 PSI; therefore, pressure controllers must be limited to the 0 to 15 PSI range.

Occasionally a steam system may be required to maintain pressure and the use of an operating controller may be necessary. In this case, two separate pressure controllers are necessary, one acting as the safety limit and the other as the operating limit. Residential steam systems require less than 2 PSI.

Most pressure controls are not sensitive enough for the low operating pressures required for some residential steam systems.

In these systems, you will get better results with a Vapor Control that operates on ounces of pressure instead of pounds.

As the steam pressure changes, an expansion or contraction of a bellows actuates the switching mechanism. The cut-in and cut-out pressures can usually be independently set to meet any requirement. The snap-acting switch type does not require leveling.

If mercury switches are employed, the control must be leveled. Figures 12-15 and

Figure 12-15:
Vaporstat



Figure 12-16:
Pressuretrol

12-16 show a vapor control and a pressure control.

In both cases the switching mechanism is actuated by a diaphragm—the steam pressure counteracts the pressure exerted by the spring in the control. The tension of the spring is predetermined by the pressure adjustment screw, or main scale set point screw.

It is important to read the pressure adjustment instructions for the particular pressure controller being adjusted. On some controls, the differential is subtractive, meaning that if the pressure cut out is set for 3 PSI and the differential is set for 2 PSI, the cut in point will be 1 PSI. On other controls, the differential is additive and if the cut in point is set at 1 psi and the differential is set at 2 PSI, then added together, it would give us a cut out point of 3 PSI.

The cut out point is the pressure at which the oilburner will shut off. The cut in point is the pressure at which the burner will restart. It is very important to remem-

Figure 12-17:
Mercury tube
pressure switch

ber that if the cut out point is changed and the differential is left the same the cut in point will also change. The same thing happens in reverse, if the cut in point is changed, the cut out point also changes.

Figure 12-17 shows a mercury tube pressure switch with the cover off, indicating various parts and adjustment points.

The pressure control must always be installed above the water level of the boiler, and a pigtail, or siphon, as shown in Figure 12-18, must be installed between the boiler and the control. The siphon loop prevents steam from damaging the control bellows.

The pressure control should be installed in the fitting provided by the boiler manufacturer, or in the pressure control mounting of the low-water cutoff. When

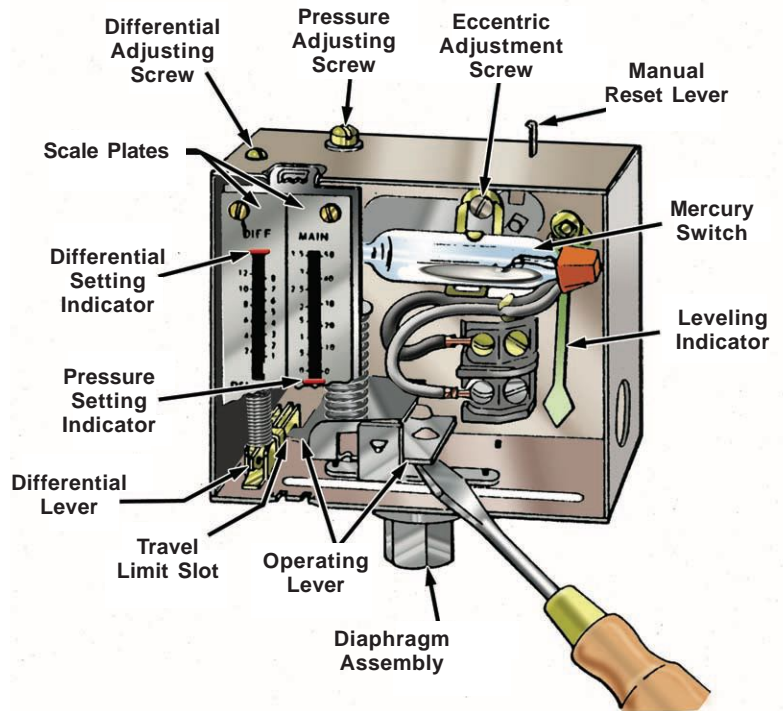

Installation of a Pressure Control

Figure 12-18:
Pressure control,
siphon loop

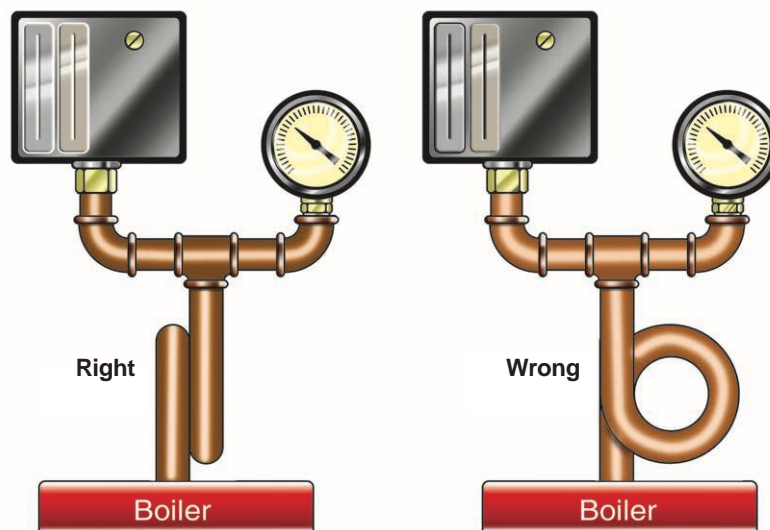

making pipe connections, use pipe dope sparingly. Excess dope may clog the small opening of the pressure control, thus preventing it from operating properly.

When mounting the pressure control and the pressure gauge to the same boiler fitting, follow the method shown in Figure 12-18, previous page. Be certain to mount them in such a manner that their faces are perpendicular to the siphon loop circumference. The reason for this is that the siphon loop tends to expand, thus causing a forward and backward motion that could cause the mercury switch in the pressure control to operate improperly if the faces of these instruments were mounted parallel to the circumference of the loop.

Figure 12-19 is a wiring diagram showing the pressure control. Like all other

high limit controls, it is wired into the hot line in series with the primary control.

Low-water cutoff

The low-water cutoff prevents a burner from operating if the water level is too low in the boiler. This device is required on all steam boilers whether used for space heating or in a process application and may also be required on hot water systems. If a hot water boiler is installed above the radiation, or even at the same level, a low-water cutoff should be used to protect the boiler in the event of a loss of water.

Figure 12-20 shows a cutaway view of an external low-water cutoff. It is a float operated device. There is also an internal low-water cutoff with the float located inside the boiler.

Figure 12-19:
Pressure control wiring

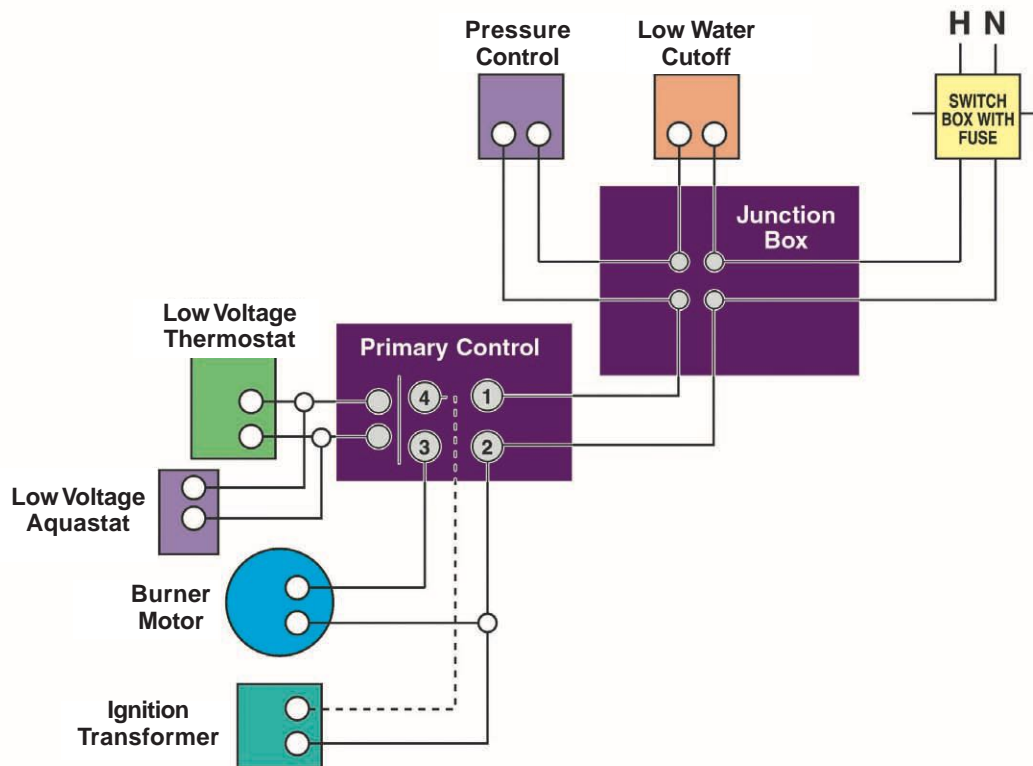

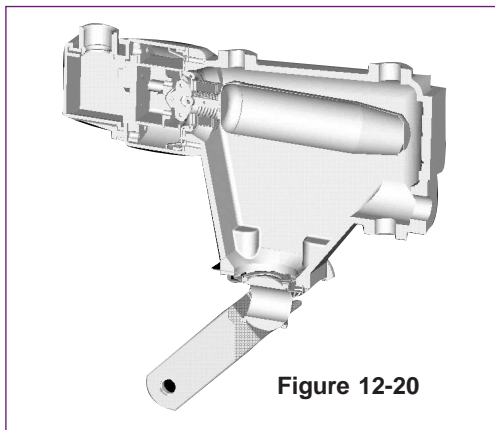

Figure 12-20

With either type, when the float is in a level position, it holds a single-pole single-throw switch in a closed position. In the event the water level inside the boiler drops below the safe operating level, the float will also drop, thus opening the switch and breaking the hot line circuit to the burner.

Probe type low-water cutoffs are becoming very common on most boilers, replacing the float types. These cutoffs may have timing devices to prevent nuisance shut downs should the boiler water surge. Probe type cutoffs send a low voltage charge through the water to ground on the boiler's metal. Don't switch to a probe control without first getting the boiler manufacturer's recommendations as to where it should be installed.

In Figure 12-19 (opposite page), the wiring diagram shows how the low-water cutoff is connected into the main heating plant circuit. The low-water cutoff is connected in the hot line, preceding the pressure control and in series with it and the primary control. Thus, the low-water cutoff may be called a low water line voltage safety device. Low-water cutoffs on steam boilers may be incorporated with, or wired to, electronic solenoid water valves called automatic water feeders.

Hot water limit controls

Hot water limit controls, sometimes called aquastats, control the temperature of the water in the boiler, and the temperature of the domestic hot water. They are all just switches that function automatically. In a basic forced hot water system, these controls must perform three functions:

1. They provide high limit protection against excessive boiler water temperatures.
2. They are employed for the purpose of maintaining a pre-determined boiler temperature, especially in systems that use tankless heaters for domestic hot water.
3. They are used to keep circulators from lowering the boiler water temperature too low.

Figure 12-21 shows a typical single function aquastat, the L4006 with two terminals and Figure 12-22 shows a dual acting L6006 with three terminals.

The high limit protection control prevents the boiler water temperature from rising to unsafe levels that create steam. Low (operating) limit protection means that the boiler water is not allowed to drop below a certain temperature. In the event the boiler water temperature falls below the dial setting of the low limit control, the burner would be turned on. Hot water temperature controls are either direct-acting or reverse-acting. As explained earlier, a direct-acting control will make its contacts, completing an electric circuit, on a drop in temperature

Figure 12-21:
Single function
aquastat

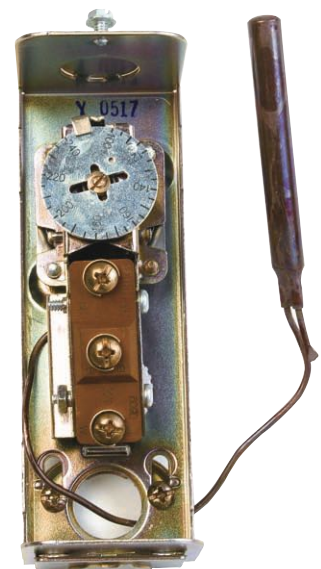
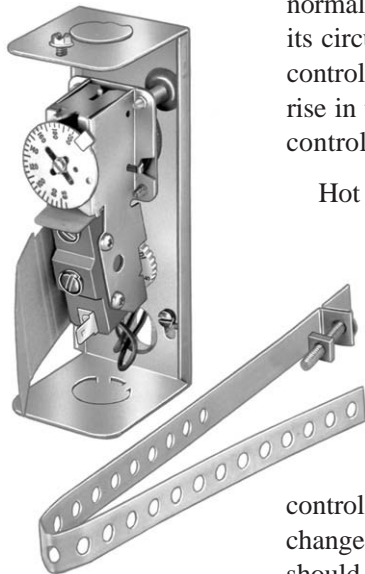

Figure 12-22:
Dual acting
aquastat

Figure 12-23:
Hot water limit
(aquastat),
strap on type



and it will break its contacts on rise in temperature. Reverse-acting controls make their contacts on a rise, and will break their contacts on a drop in temperature. The letter A after the Honeywell model number normally indicates a control that will open its circuit on a rise in temperature. The B control will normally close its circuit on a rise in temperature for use as a reverse control.

Hot water limits may be of the strap-on type (Figure 12-23, or the immersion type, (Figure 12-24). Normally, the strap-on limit control is installed close to the boiler on the main supply riser. It should never be mounted on a pipe fitting such as an elbow or coupling. The strap-on type control is not as sensitive to temperature change as the immersion type controls and should not be used as a high limit control. Immersion controls should be installed in the tapped holes recommended by the boiler manufacturer.

The temperature sensing element on hot water controls may be electronic thermistors, thermocouples, liquid filled elements, or helical bimetal elements. Liquid filled elements, or capillary sensing bulbs, are the most popular. Volatile liquid expands and contracts dramatically with changes in temperature. This expansion and contraction operates an internal

diaphragm to open and close the switch. When installing the heat sensing bulb in the aquastat well, coat the bulb with the heat conductive compound, supplied with the control, to help transfer the heat from the well to the bulb. The immersion control equipped with a

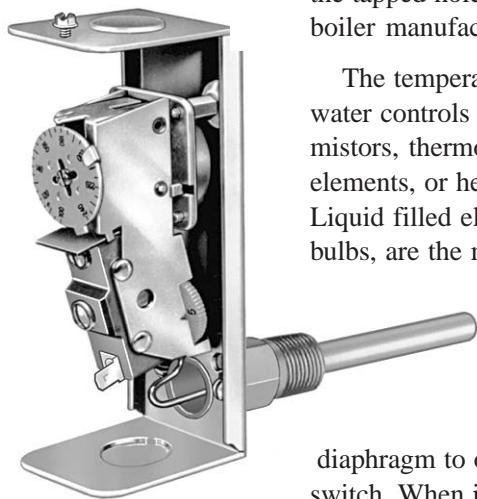

Figure 12-24:
Hot water limit
(aquastat),
Immersion type

thermistor, (Figure 12-25), will respond faster to rapid temperature changes than the old immersion control of the bi-metal type or the capillary type. A thermistor is a heat sensitive device that increases or decreases resistance based on temperature.

Reverse acting aquastat

When the circulator is turned on by action of the room thermostat, the burner often starts simultaneously. When the circulator starts, it pushes hot water out of the boiler to the radiators, and an equal volume of cool return water from the radiators and system piping flows back to the boiler. This causes a drop in boiler water temperature. Starting the burner at the same time as the circulator helps the burner match its output to the heat content leaving the boiler.

Also, in the event that the water temperature goes too low, the reverse-acting circulator control will function to stop the circulator until burner operation can restore effective boiler water temperature. Then the circulator limit will again close its contacts to turn the circulator on.

Without the reverse acting aquastat, if a thermostat calls for heat while someone is taking a shower, the circulator comes on and sends all the heat in the boiler into the radiation and the boiler temperature drops below what is needed to produce hot water; the result is that the shower water temperature change can be quite noticeable. The reverse acting aquastat shuts the circulator off until the burner can build enough heat in the boiler to keep the tankless coil hot and heat the radiation.

The second reason for a reverse acting aquastat is to keep the products of combustion from condensing in a high



Figure 12-25:
Thermistor

efficiency boiler. The new, high efficiency boilers extract so much heat from the products of combustion that they can lower their temperature below the dew point of the combustion gases. At this temperature, the water vapor turns to water. While it does this, it picks up the sulfuric oxides in the gases and creates sulfuric acid. This results in scale build-up on the heat exchanger.

The reverse acting aquastat minimizes the scale build-up. When the boiler water temperature falls below the set point, the aquastat shuts off the circulator and the heat from the burner raises the boiler water temperature. This allows the temperature of the combustion gases to stay above the dew point. See the chapter on combustion theory (Chapter 7) for more detail.

Immersion aquastats should be mounted as follows:

1. When mounting immersion aquastats, try to avoid using bushings on the well. Bushings may prevent the temperature sensing element from extending far enough into the boiler water to be in the direct path of the hot water. Locate the element in freely circulating water.
2. Handle the aquastat with care. Do not damage the sensing element.
3. The bulb of the immersion aquastat should bottom in its well.
4. Be certain that the sealing washer is in place (remote control).
5. Make certain the case is mounted level if a mercury switch is employed.

The domestic hot water

low limit (operating) control used for controlling the domestic hot water supply should be installed on the boiler as close as possible to the hot water generator on a tankless hot water heating unit. In the event a tank is used for hot water storage, it may be installed in the hot water tank. With most hot water producing boilers, this control must be wired in parallel with the thermostat.

The reverse-acting circulator control should be installed in the boiler where the water returning from the circulator will surround the temperature sensing element. Figure 12-26 shows all three types of aquastats wired into a one zone circuit with the use of a switching relay.

Switching relays

Switching relays control a line voltage load with a low voltage thermostat. They are used

Figure 12-26

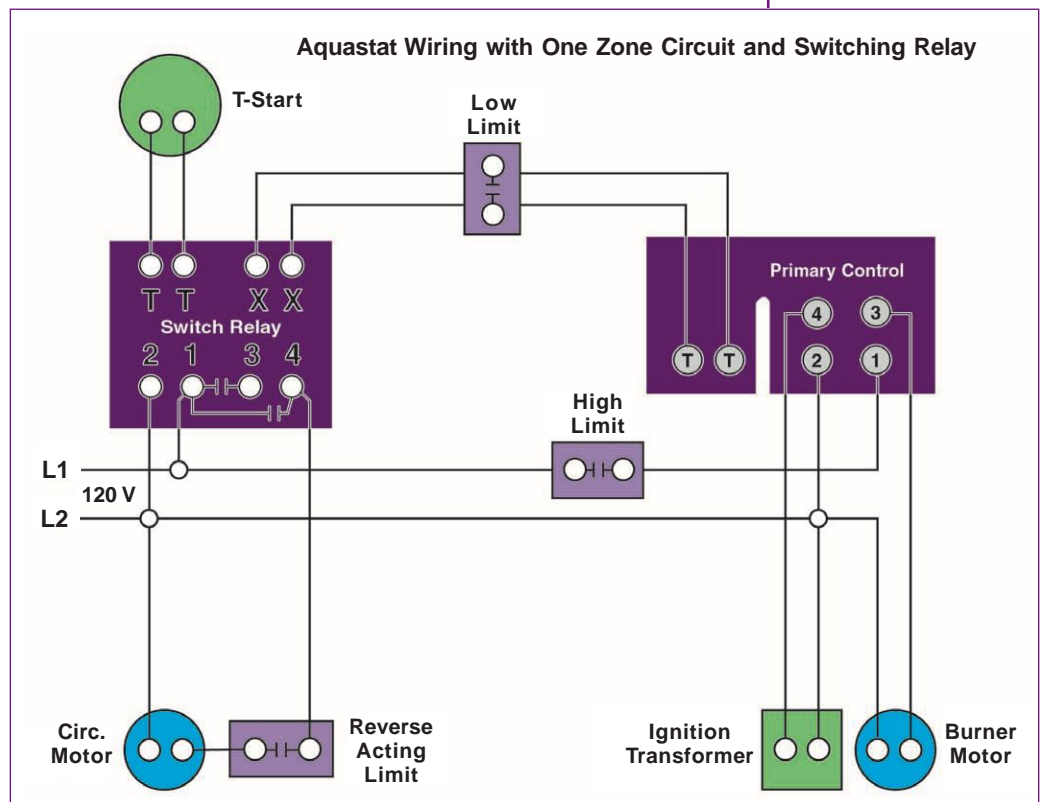

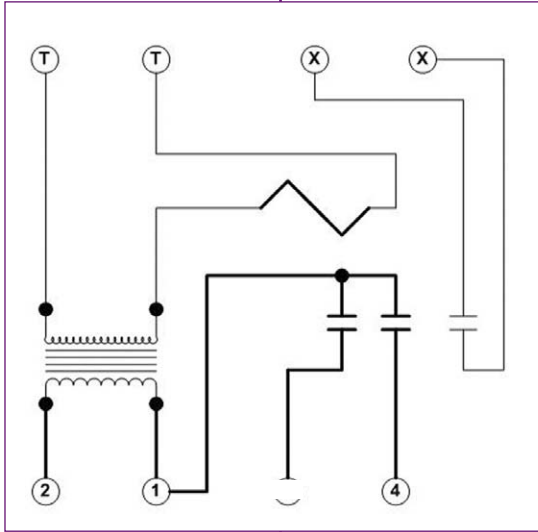

Figure 12-27:
Double-pole, single
throw (DPST) relay

extensively on forced hot water systems to provide for multiple zones. In order for a switching relay to use a low voltage switch (thermostat) to control the line voltage loads (the circulator), it must contain a step down transformer (from 120 to 24 volts), a relay or relays and the necessary line and low voltage connections.

Most of today's switching relays are double-pole, double-throw (DPDT), but relays can be found in several configurations. This is the oldest type and can control only one load without exceeding the contact current capacity of the relay.

Figure 12-27 shows a double-pole, single-throw (DPST) relay that allows for two devices to be switched at the same time. A good application for this type of relay is where the switching relay turns on the circulator and primary control.

the circulator and primary control.

Figure 12-28 shows a DPDT switching relay for use with a low voltage, low (operating) limit control. A typical use for this control is to control an additional zone with a combination control package that will provide for high limit, low limit and circulator operation.

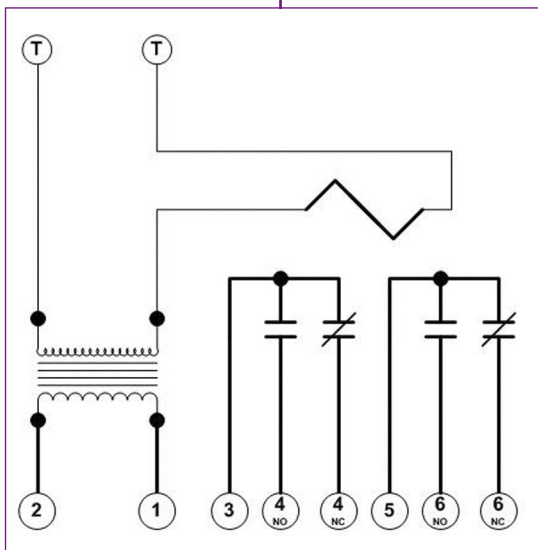
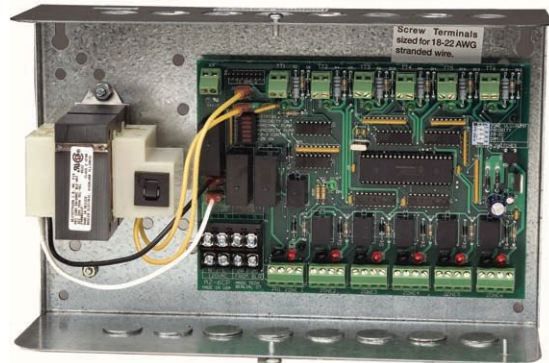

Figure 12-28:
DPDT switching relay

Figure 12-29: Panel used with circulators



Figure 12-30: Zone valves panel



Multiple zone switching relays can also be used to reduce costs and simplify wiring when several zones are used. Figure 12-29 shows a panel used with circulators and Figure 12-30 shows a zone valves panel. Note that both panels can work with all makes and wiring configurations of thermostats, zone valves and circulators.

Hydro air fan controls

Figure 12-31 shows a wiring diagram for a typical hydro air fan control. A hydro air system uses boiler water pumped through a fan coil for heating. The fan coil is mounted in an air handler along with the air conditioning coil from the compressor. With these units you can use hot water to heat the air flowing through the same ducts used for summer cooling. The controls are

the interface between the thermostat and the air handler. They have an isolated end switch to start the boiler and/or circulator.

When the thermostat calls for heat, the fan control energizes the end switch relay and allows the fan to operate at low speed when the water temperature is above the aquastat setting. When the thermostat calls for cooling, the fan control energizes the condenser and operates on high speed. Many of these relays also allow selectable one, three, four minute delay on fan operation in the heating mode. Many of these relays also allow selectable one, three, and four minute delay on fan operation in the heating mode.

Combination controls

When the controls are separate units and scattered around the boiler, they are referred to as non-integral controls. When they are all in one box, high limit, low limit and circulator controls are called integral controls. They are also available in dual capacity high limit and low limit, or as triple function controls acting as high limit, low limit, and reverse-acting circulator limit.

In older heating systems, non-integrated control systems were used much more than they are now. Today's systems are generally integrated control systems that provide control of both the burner and circulator by

Figure 12-31:
Diagram of typical hydro fan control
(Both HAFC 101 and HAFC 201 are capable of 1 and 2 speed applications)

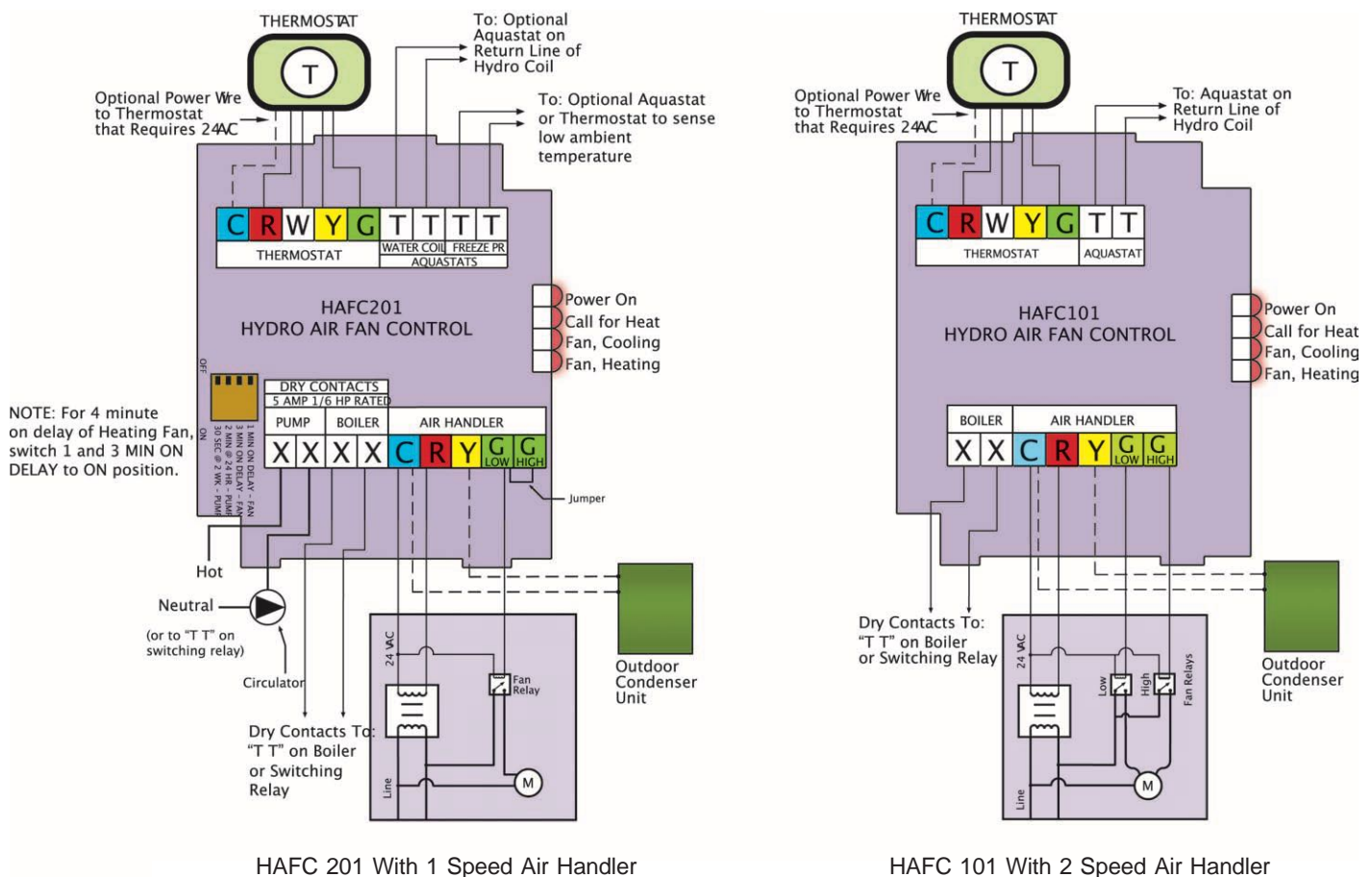

the room thermostat, and are preferred because many new boilers have a boiler water capacity of only a few gallons. Since space and accuracy are also factors, these combination controls are almost always now integral packages.

Triple acting aquastat relays

Dual and triple function aquastat controllers incorporate all of the various limit functions. Only one boiler water immersion element is required, simplifying installation. Figure 12-32 is a schematic diagram of a triple acting controller, the Honeywell L8124A. This controller incorporates a line voltage circuit, a low voltage circuit, and a switching relay, and includes all three limit controls: low, high, and reverse.

Assume that the low limit is set to open at 170°F, the high limit is set to open at 200°F, and the differential is set at 20°F. The system may be analyzed as follows:

When the thermostat calls for heat, it closes its switch, energizing the low voltage circuit through the secondary (24 volt) coil of the step-down transformer. The IK solenoid electromagnet is energized, pulling in the relay clapper, making contact IK1, closing the line voltage circuit to start the circulator that also closes contact IK2 in the line voltage circuit to start the oilburner at the same time.

The circulator limit switch in the circulator hot line must be closed to allow the circulator to operate. It will be closed if the boiler water temperature is above 180°F. If this switch is open, only the burner will operate, which will cause the boiler water temperature to increase to 180°F and then the circulator limit switch

will close and the circulator will start. The reason for this is that the low limit has a built in differential of ten degrees. The differential is added to the set point, less the differential. So, you subtract 10 degrees from the 170°F set point to get 160°F and then add 20°F to this number. In the summer, the burner will operate between 160°F and 180°F working off of the 20° differential.

The high limit switch is located in the burner hot line and it must be closed to allow the burner to operate. It will always remain closed unless the boiler water temperature is higher than 200°F. This switch will again close the circuit when the water temperature drops below 190°F based on its 10° fixed differential.

When the thermostat is satisfied, the circulator will stop and the burner may also stop, or it may continue to operate for a short period if boiler water temperature is below 160°F.

This is the control operation during a normal heating cycle, from thermostat on to thermostat off. Now when a hot water boiler also provides domestic hot water, the low (operating) limit functions, to cause the burner to run and heat the boiler water year round to provide adequate domestic hot water through the tankless or the tank type coil installed in the boiler.

The low limit switch closes to run the burner when the boiler water temperature drops below 160°F. It is desirable to open the circulator switch at the same time so that the circulator cannot operate until proper water temperature is again restored. The control manufacturer has incorporated a Single Pole Double Throw (SPDT) switch installed in the hot line to both the circulator and the burner for this purpose.

Figure 12-32:
Schematic diagram
for a triple acting
controller, Honeywell
L8124A

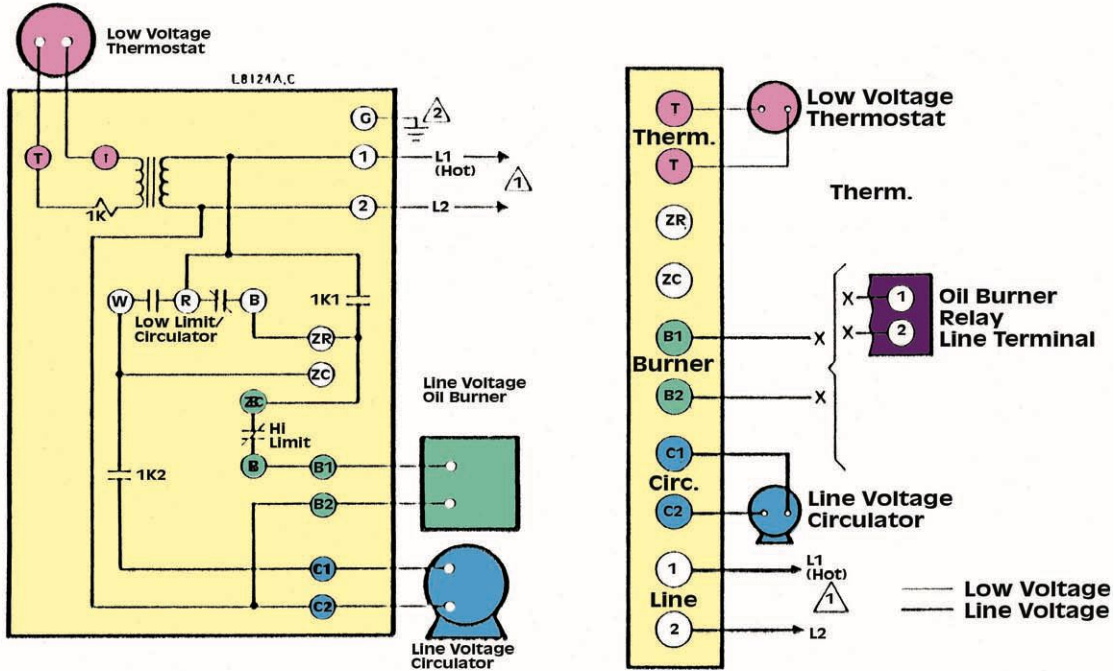

Shows how the external connections will often appear in the instruction sheet with the control.

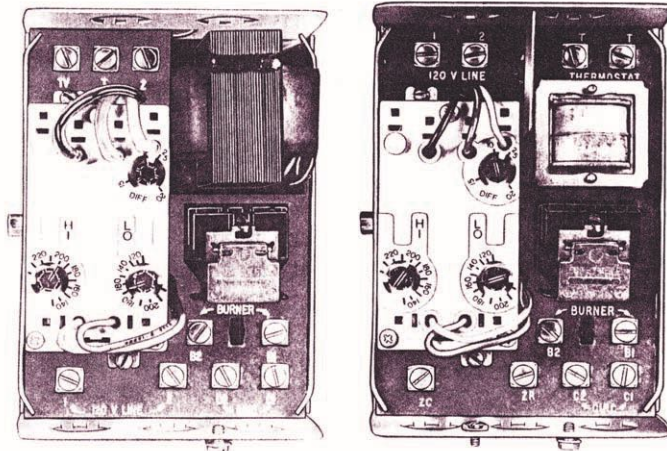

Note that the hot line, starting at terminal 1, goes directly to a point midway between the low limit switch and the circulator limit switch. This point is the hot side of a SPDT switch that is actuated by the heat sensing element immersed in the boiler water.

If the water temperature is below 160°F, the double-throw switch will close the hot line to the burner by moving its contact up to terminal B, allowing power to pass to B1 and the primary control. The thermostat terminals, T and T of the primary, are now closed so the burner starts and will continue to operate until the water temperature reaches 180°F. Then the double-throw switch will transfer its contact from B to W and the burner stops. The boiler water temperature has now been restored to effectively provide domestic hot water. When the thermostat again calls for heat, the circulator can operate. The burner can be energized in two ways: first by an action of the thermostat and second by action of the SPDT switch even when the thermostat is not calling for heat.

Figure 12-32 (previous page) also shows terminals ZC and ZR. These terminals are used when circulated zones are added to the system. When a call for heat energizes the zone relay, the use of these two terminals enables the control to act as though the main zone circulator was called. The control will start the burner and drop out the circulator if the boiler water temperature drops below the low limit/differential set point. This ensures consistent tankless coil performance.

Caution

Be careful when wiring hot water heating systems with multiple zones not to hook one set of powered terminals to another. The thermostat circuit (usually TT) is powered by the transformer in that control. Never hook wires from TT of one control to the TT of another control or switching relay. This will apply 48 VAC to the circuit and burn out the controls.

Since there may be differences in control models as well as control manufacturers, you are urged to study the operation of the various makes of controllers covered in the data and instruction sheets supplied by the manufacturer of the control.

Testing limit controls

High limit controls

1. With the burner operating and the room thermostat calling for heat, move the limit indicator to the low end of its scale.
2. Allow the burner to operate so that either the temperature or the pressure of the furnace or boiler rises to the limit setting. The burner should shut down. If it does not, then the limit control is either improperly installed or defective.
3. If it does shut down, then set the indicator at the desired temperature or pressure.

Circulator controls

1. Set the thermostat to call for heat.
2. In the event the boiler water temperature is above the circulator switch (reverse acting aquastat) setting, the circulator relay should close its contacts and the circulator should operate.
3. Next, turn the thermostat down below room temperature. This should cause the circulator relay to open its contacts and stop the circulator.
4. If the boiler water temperature is below the circulator switch when the thermostat is turned up and calls for heat, the circulator should not operate until the burner has heated the boiler water to the setting of the circulator control. In the event the circulator does not operate as outlined above, then the circulator control is either improperly installed or faulty.