

USER'S INFORMATION

G12, G12R and G12X Series Units

GAS UNITS
502,253M
8/90
Supersedes 3/88

RETAIN THESE INSTRUCTIONS FOR FUTURE REFERENCE

FOR YOUR SAFETY

Do not store or use gasoline or other flammable vapors and liquids in the vicinity of this or any other appliance.

WARNING

Improper installation, adjustment, alteration, service, or maintenance can cause injury or property damage. Refer to this manual. For assistance or additional information, consult a qualified installer, service agency, or the gas supplier.

FOR YOUR SAFETY

WHAT TO DO IF YOU SMELL GAS:

- Do not try to light any appliance.
- Open windows.
- Do not touch any electrical switch; Do not use the phone in your building.
- Immediately call your gas supplier from a neighbor's phone. Follow the gas supplier's instructions.
- If you cannot reach your gas supplier, call the fire department.

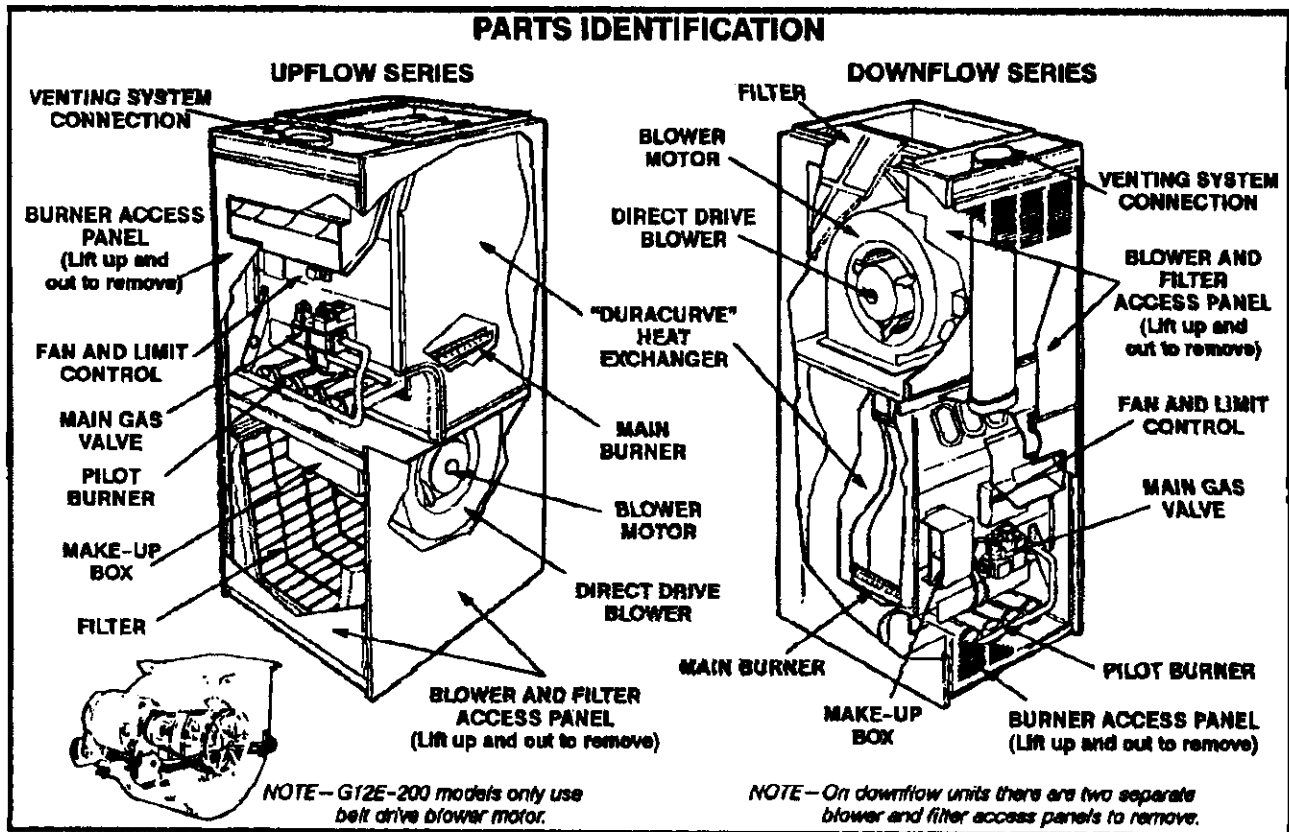

FIGURE 1

WARNING—Should overheating occur or the gas supply fail to shut off, shut off the manual gas valve before shutting off electrical supply.

WARNING—Do not use this furnace if any part has been under water. Immediately call a qualified service technician to inspect the furnace and replace any part of the control system and any gas control that has been under water.

CAUTION—Before attempting to perform any service or maintenance, turn electrical power off to unit at unit disconnect switch.

I-IMPORTANT DIRECTIONS

1- Keep furnace area clear and free of combustible materials, gasoline and other flammable vapors and liquids.

If installed in an insulated area, furnace must be kept free of insulating material. Insulating material may be combustible.

Inspect unit venting system to make sure it is in place, physically sound and without holes, corrosion or blockage.

Inspect return air duct to ensure duct is sealed to the furnace and terminates outside the space containing appliance.

Inspect physical support of unit to guarantee that it is sound without sagging, cracks, or gaps around base and it maintains seal between base and support.

- 2- Do not obstruct air flow to unit. Unit must receive an unobstructed flow of combustion and ventilating air.
- 3- Do not store chlorine or fluorine products near unit or introduce these products into the combustion air. These products can cause furnace corrosion.

II-LIGHTING INFORMATION AND OPERATION

FOR YOUR SAFETY READ BEFORE LIGHTING

WARNING—If you do not follow these instructions exactly, a fire or explosion may result causing property damage, personal injury or loss of life.

BEFORE LIGHTING smell all around the appliance area for gas. Be sure to smell next to the floor because some gas is heavier than air and will settle on the floor.



Use only your hand to push in or turn the gas control knob. Never use tools. If the knob will not push in or turn by hand, do not try to repair it, call a qualified service technician. Force or attempted repair may result in a fire or explosion.

This unit is equipped with an automatic gas valve using a standing (constant) pilot flame or an intermittent pilot ("E" and "X" series units). Standing pilot units require manual lighting of pilot flame. Intermittent pilot models have a pilot ignitor. Do NOT try to manually light the pilot on an "E" or "X" series unit.

A-Placing Furnace in Operation

Standing Pilot Lighting Information

Refer to lighting instructions sticker on blower access panel and figure 2 for gas valve identification.

- 1- STOP! Read the pilot safety information in previous section.
 - 2- Set thermostat to lowest setting. See figure 3.
 - 3- Turn off all electrical power to appliance.
 - 4- Remove burner access panel.
 - 5- Push in gas valve knob slightly and turn clockwise  to OFF. See figure 5.
- NOTE*-Knob cannot be turned from PILOT to OFF unless knob is depressed. Do not force.
- 6- Wait five (5) minutes to clear out any gas. If you then smell gas, STOP! Immediately call your gas supplier from a neighbor's phone. Follow the gas supplier's instructions. If you do not smell gas go to next step.
 - 7- Remove the pilot access panel located below and behind the gas valve.
 - 8- Locate pilot—follow metal tube from gas valve. See figure 6. The pilot is between the two burner tubes behind the pilot access panel.
 - 9- Turn knob on gas valve counterclockwise  to PILOT.

- 10- Push in knob on gas valve all the way and hold in. Immediately light pilot with a match. Continue to hold the gas valve knob in for about one minute after the pilot is lit. If it goes out, repeat steps 5 through 10.

If knob does not pop up when released, stop and immediately call your service technician or the gas supplier.

If pilot will not stay lit after several tries, turn the gas valve knob to OFF and call your service technician or gas supplier.

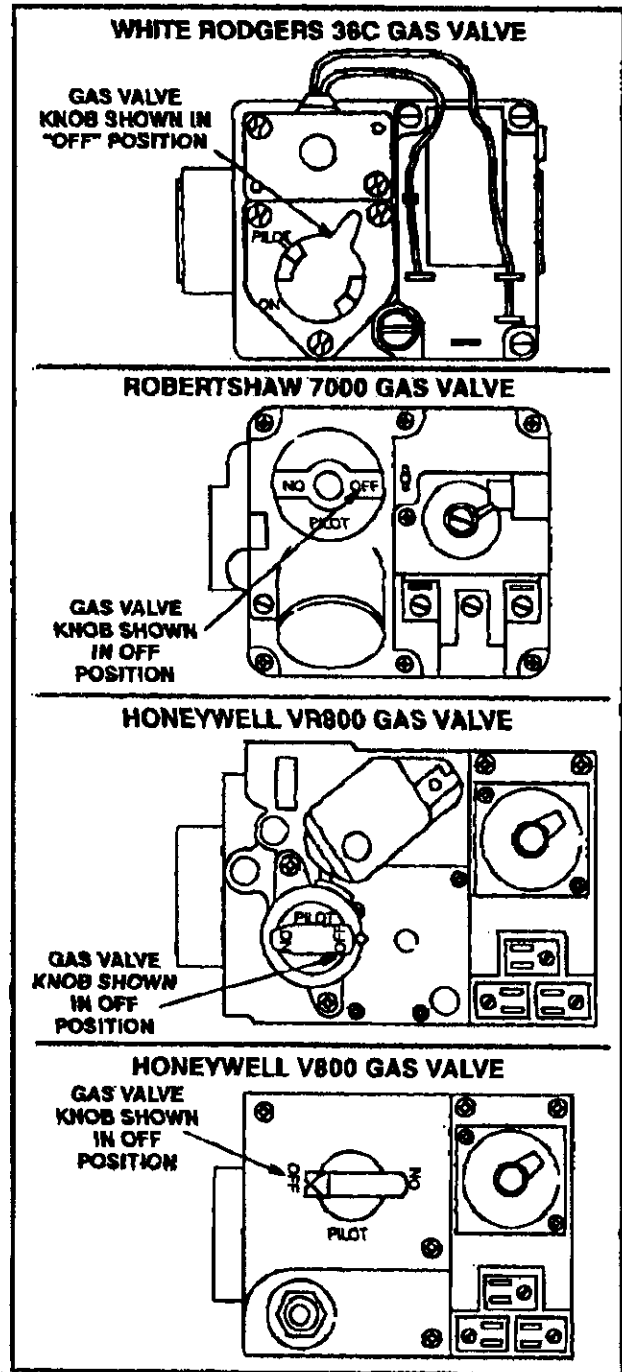



FIGURE 2

- 11- Replace pilot access panel.
- 12- Turn gas valve knob counterclockwise to ON. 
- 13- Replace burner access panel.
- 14- Turn on all electrical power to unit.
- 15- Set thermostat to desired setting.

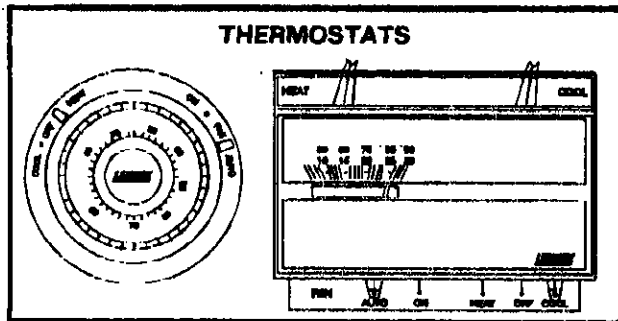

FIGURE 3

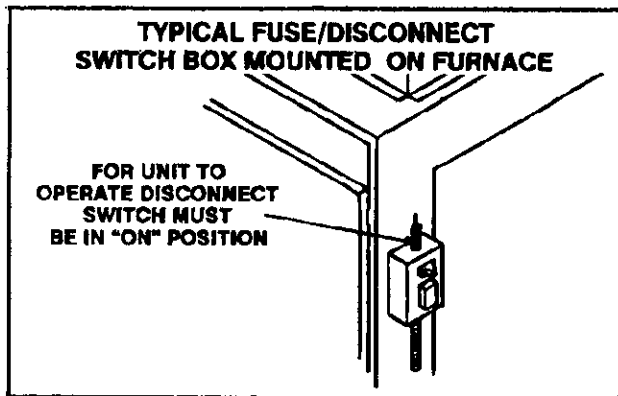

FIGURE 4

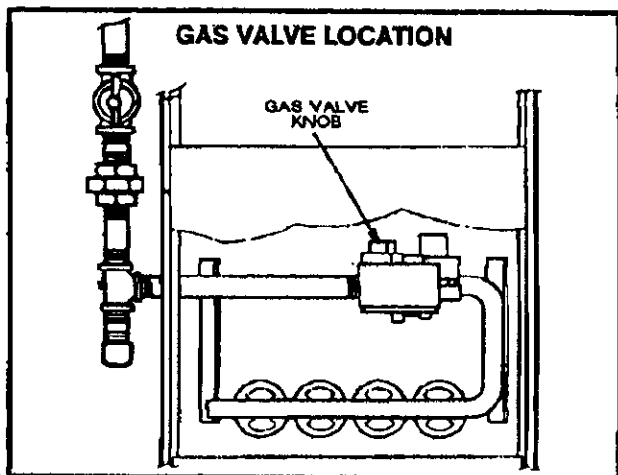

FIGURE 5

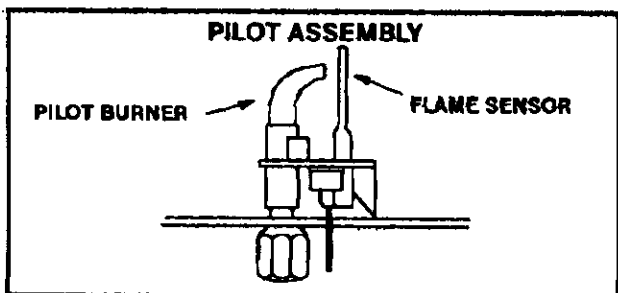
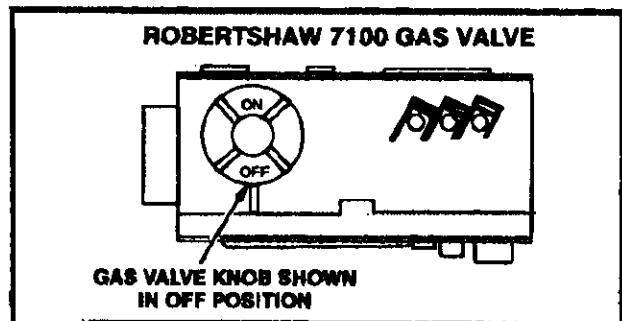
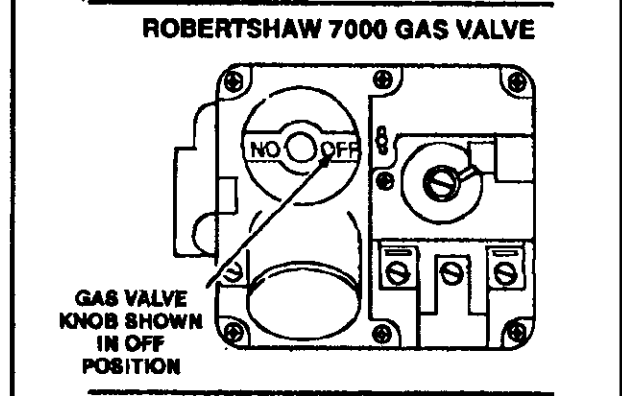

FIGURE 6



GAS VALVE KNOB SHOWN IN OFF POSITION



GAS VALVE KNOB SHOWN IN OFF POSITION

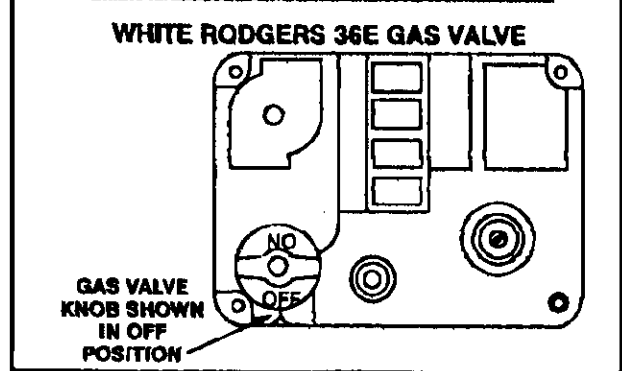

GAS VALVE KNOB SHOWN IN OFF POSITION

FIGURE 7

Intermittent Pilot Operation Information

Refer to gas valve operation sticker and figure 7 for gas valve identification.

- 1- STOP! Read the safety information in the previous section.
- 2- Set thermostat to lowest setting. See figure 3.
- 3- Turn off all electrical power to appliance. See figure 4.
- 4- This appliance is equipped with an ignition device which automatically lights the burner. Do not try to light the burner by hand.
- 5- Remove burner access panel.
- 6- Turn knob on gas valve clockwise to OFF. Do not force.

- 7- Wait five (5) minutes to clear out any gas. If you then smell gas, STOP! Immediately call your gas supplier from a neighbor's phone. Follow the gas supplier's instructions. If you do not smell gas go to next step.
- 8- Turn knob on gas valve counterclockwise  to ON.
- 9- Replace burner access panel.
- 10- Turn on all electrical power to unit.
- 11- Set thermostat to desired setting.
- 12- If the appliance will not operate, follow the instructions "To Turn Off Gas To Unit" and call your service technician or gas supplier.

B-To Turn Off Gas To Unit

- 1- Set thermostat to lowest setting.
- 2- Turn off all electrical power to unit if service is to be performed.
- 3- Remove unit access panel.
- 4- Turn knob on gas valve clockwise  to OFF. Do not force.

NOTE- On standing pilot units, the gas valve knob must be depressed slightly to turn to OFF. Do not force.

- 5- Replace unit access panel.

**TABLE 1
FILTER MEDIA DIMENSIONS**

Unit	Filter Type (Quantity)	Dimension All filters 1 in. (25mm) in. x in. (mm x mm)
G12E-200	Hammock (1) 2/3Hammock (1)	52" x 28" (1321 x 711) 46" x 28" (1130 x 711)
G12Q3-82, G12Q2/3X-60	Hammock (1)	38" x 28" (914 x 711)
G12Q3E-82 G12Q3E-40 G12Q3E-28	2/3Hammock (1)	30" x 28" (775 x 711)
G12Q3-110; G12Q3E-110 G12Q3/4X-80;	Hammock (1)	40" x 28" (1016 x 711)
G12Q4E-110; G12Q4-110 G12Q4E-50 G12Q4E-80	2/3Hammock (1)	32" x 28" (800 x 711)
G12Q3-137; G12Q4-137 G12Q4/5X-100;	Hammock (1)	52" x 28" (1321 x 711)
G12Q5-137; G12Q5E-75 G12Q5E-100; G12Q3E-137 G12Q4E-137; G12Q5E-137	2/3Hammock (1)	42" x 28" (1066 x 711)
G12Q5-185	2/3Hammock (1)	48" x 28" (1130 x 711)
G12Q2X-40; G12D2-55 G12D2-82; G12D2E-40 G12D2E-55; G12D-110 G12Q3E-82; G12D2E-110	Slab (1)	16" x 25" (406 x 625)
G12RQ2-65; G12RQ3E-82 G12RQ2E-65 G12RQ2-82; G12RQ3-82	Slab (2)	10" x 20" x 1" (254 x 508 x 25)
G12RQ3-137 G12RQ3E-110	Slab (2)	12" x 20" x 1" (305 x 508 x 25)
G12RQ3-137; G12RQ3E-137 G12RQ5-137; G12RQ5-137	Slab (2)	16" x 20" x 1" (406 x 508 x 25)
G12RQ6-165; G12RQ6-165	Slab (2)	16" x 20" x 1" (406 x 508 x 25)

III-SERVICE

A-Servicing Filter

Inspect and replace furnace air filters twice annually (minimum). Recommended times are before heating and cooling seasons. Table 1 lists filter sizes.

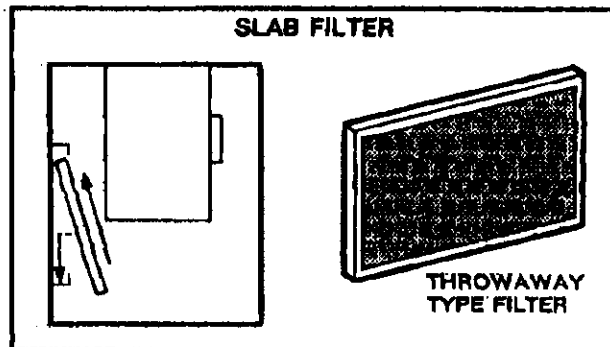
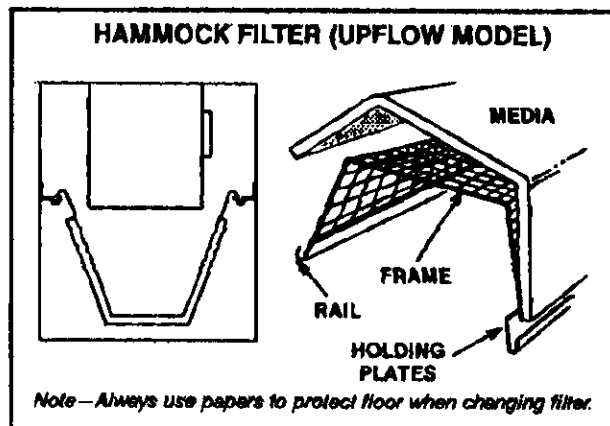

FIGURE 8

B-Filter Replacement of Slab Type Filters in Up-flow Units

- 1- Turn off power to furnace at unit disconnect switch. See figure 4.
- 2- Remove filter access panel. Wait for blower to stop.
- 3- Remove filter by sliding it up and out of filter channel. See figure 8.
- 4- Slide new filter up into top channel and drop into lower channel.
- 5- Replace filter access panel.



Note- Always use papers to protect floor when changing filter.

FIGURE 9

C-Filter Replacement of Hammock Filter in Up-flow Units

- 1- Turn off power to furnace at unit disconnect switch. See figure 4.
- 2- Remove filter access panel. Wait for blower to stop.

- 3- Slide hammock filter assembly from unit. See figure 9.
- 4- Release media holding tabs by sliding holding plates lengthwise. Rotate holding plates up and remove media from hammock frame.
- 5- Position new filter media, with colored side out, to hammock frame. Close holding plate and hook the holding tabs.
- 6- Slide hammock filter assembly back into unit and install access panel.
- 7- Restore power to unit.

D-Filter Service for G12R-55/82 Units

- 1- Turn off power to furnace at unit disconnect switch. See figure 4.
- 2- Remove blower access panel and right vestibule panel.
- 3- Remove securing spring from slotted center support tab and right filter rail. See figure 10.
- 4- Using slotted center support tab as a handle, slide right filter slightly left to clear right filter rail. Slide filter downward to the right, below filter rail and around blower and remove filter from cabinet.
- 5- Remove left filter by lifting up and around blower and through right vestibule opening.
- 6- Wash permanent slab filters with water and mild detergent. When dry, filters should be sprayed with filter Handicoater before replacing. Filter Handicoater is RP products No. 418 and is available as Lennox part no. P-8-5069.
- 7- Reverse order of above steps to reinstall filters.

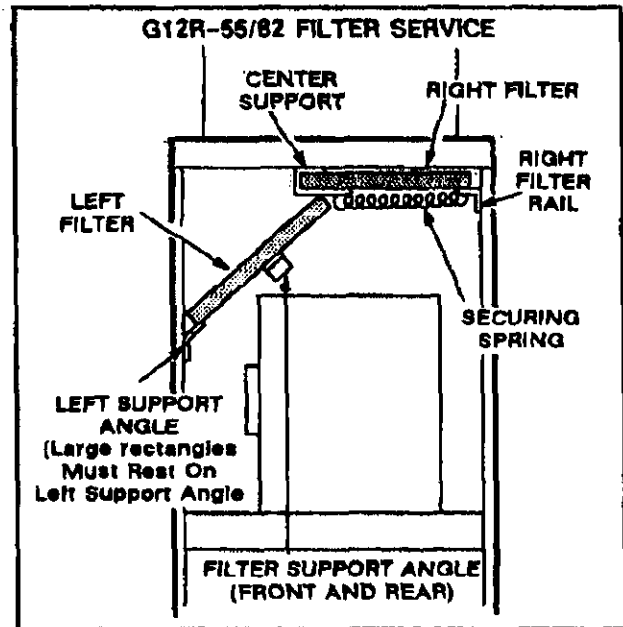

FIGURE 10

E-Filter Service for G12R-110 Series Units

- 1- Turn off power to furnace at unit disconnect switch. See figure 4.
- 2- Remove burner access panel and right vestibule panels.
- 3- Remove filters by pushing up and around filter guide rails. See figure 11.
- 4- Reusable foam filters supplied with G12R-110 units can be washed with water and a mild detergent. When dry, filters should be sprayed with filter Handicoater before replacing. Filter Handicoater is RP products No. 418 and is available as Lennox part no. P-8-5069.
- 5- Reverse order of above steps to reinstall filters.

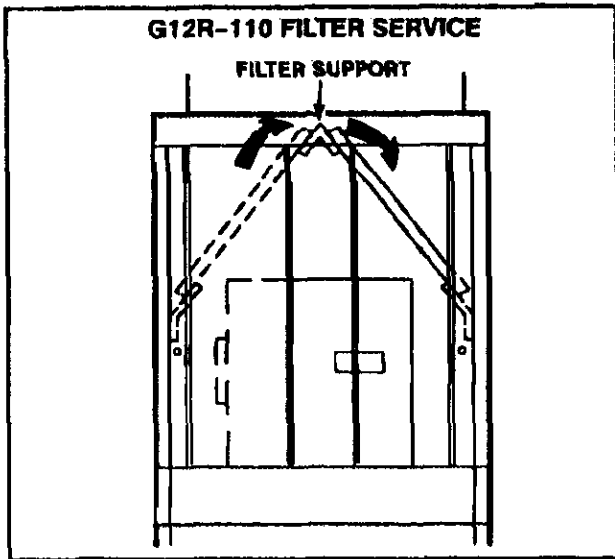

FIGURE 11

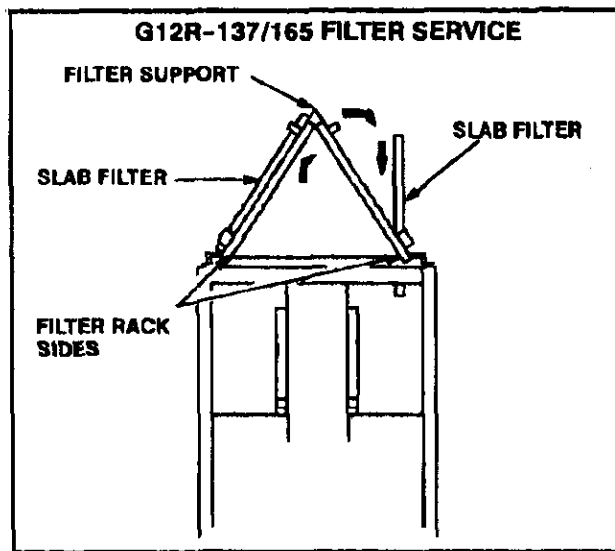

FIGURE 12

F-Filter Service for G12R-137/165 Units

- 1- Turn off power to furnace at unit disconnect switch. See figure 4.
- 2- Remove blower access panel and blower compartment panels.
- 3- Lift filter vertically, and drop it down through lower slot in filter rack side. See figure 12.
- 4- Drop filter into blower compartment. Turn filter and remove.
- 5- Repeat for other filter.

- 6- Reusable type filters supplied can be washed with water and a mild detergent. When dry, filters should be sprayed with filter Handicoater before replacing. Filter Handicoater is RP products No. 418 and is available as Lennox part no. P-8-5069.
- 7- Reverse order of above steps to reinstall filters.

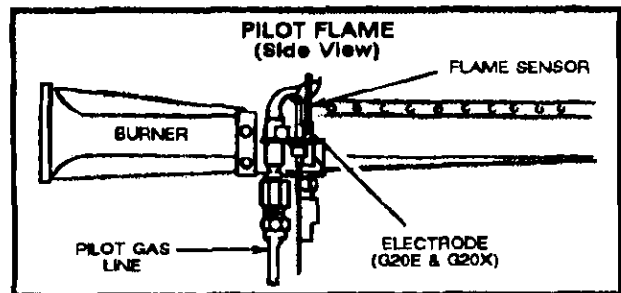

FIGURE 7

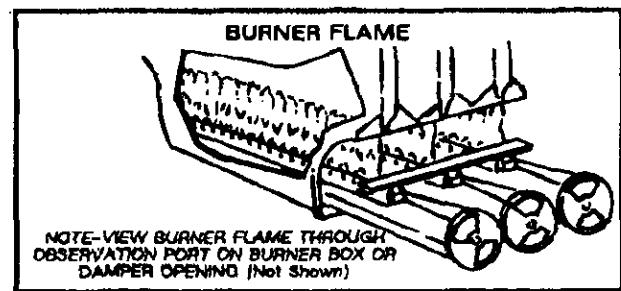

FIGURE 8

V-PILOT AND BURNER FLAME

CAUTION—Before each heating season and periodically thereafter inspect burner flame to ensure proper operation.

- 1- Pilot Flame—Pilot flame must surround the end of flame sensor for proper operation of pilot safety-circuit.
- 2- Burner Flame—Start burner and allow to operate for a few minutes to establish normal burning conditions. Check burner flame by observation. Flame should be predominantly blue in color, strong in appearance and should rise directly from the burner ports in the heat exchanger.

VI-LUBRICATION

Blower Motors—Motors are prelubricated and sealed for extended life. No further lubrication is needed.

IV-FURNACE VENTING SYSTEM INSPECTION

Annually (before heating season) inspect furnace venting system, draft hood, vent cap, heat exchanger, burners and pilot for corrosion, deterioration, or deposits of debris. Remove any obstructions or blockage.

Periodic Unit Inspection

Contact your Lennox dealer for a periodic unit inspection by a qualified technician.

VI-SERVICE REMINDER

Call your Lennox dealer if the unit is inoperative. Before calling, always check the following to be sure service is required:

- 1- Be sure electrical disconnect switches are ON.
- 2- Check room thermostat for proper setting.

- 3- Replace any blown fuses or reset circuit breakers.
- 4- Gas valve(s) should be ON for heating cycle.
- 5- Air filters should not be plugged, limiting air flow.
- 6- Make sure all access panels are in place.

IMPORTANT-This furnace is equipped with a vent safety shut-off switch. This switch locks out furnace operation when vent is blocked.

If this switch shuts off furnace, vent system must be checked by a qualified service technician. Do NOT attempt to place furnace into operation.

VII-PLANNED SERVICE

To keep your Lennox heating and cooling system in peak operating condition year after year, contact your Lennox dealer about a planned service program.