

# **Model R & S Burner Instruction Manual**

FOR  
GAS AND PRESSURE ATOMIZING LIGHT OIL FUEL SYSTEMS  
MANUFACTURED BY JOHN ZINK COMPANY, LLC

---

**NOTE:** YOUR BURNER MAY HAVE A LETTER PREFIX OR SUFFIX ADDED TO THE MODEL DESIGNATION. HOWEVER, THIS IS FOR IDENTIFICATION PURPOSES ONLY AND DOES NOT AFFECT THE INSTRUCTIONS IN THIS MANUAL.

**For replacement parts contact OEM Boiler Parts**

**[www.gordonpiatt.com](http://www.gordonpiatt.com)**

**717-367-9900**

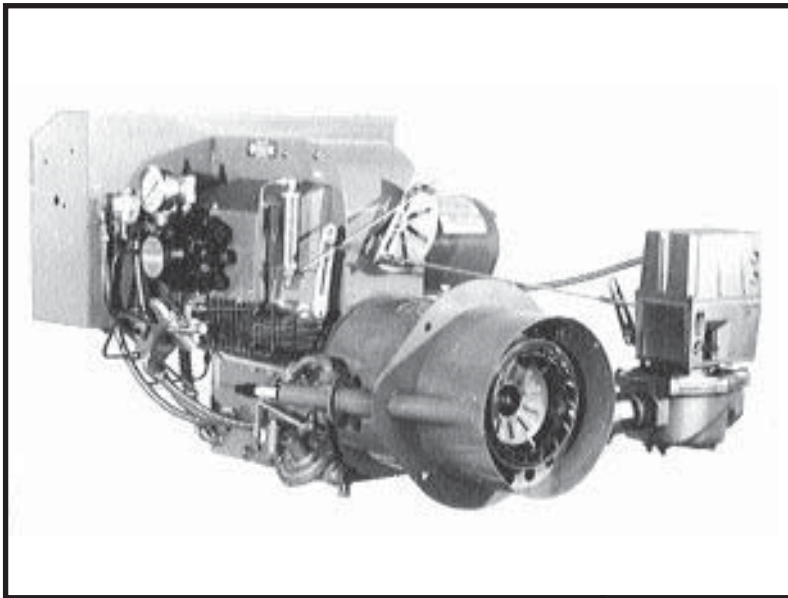

**The illustration at left shows a typical Model R6, R8 or R10 burner with combination gas-oil fuel system. General appearance may differ between units because of size and fuel system used. The oil pump is normally burner mounted on these size units.**

**The illustration at right shows a typical Model S6, S7, S8 or S10 burner with combination gas-oil fuel system. General appearance may differ between units because of size and fuel system used. The oil pump is normally burner mounted on these size units.**

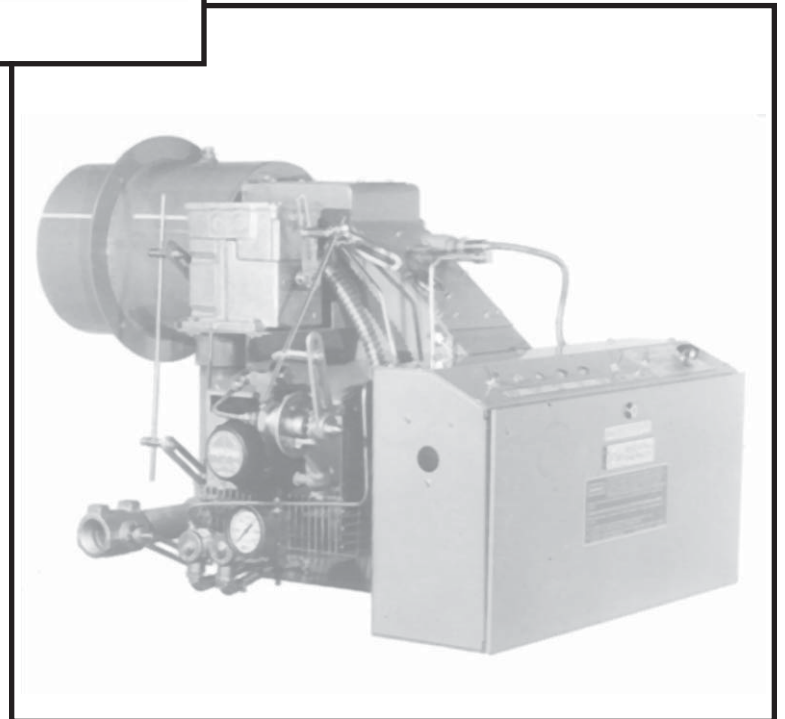

These burners are listed by UL, CSA, The New York Board of Standards and Appeals, the State Fire Marshal of the Commonwealth of Massachusetts and others. Burners and controls are also available which comply with **FM, IRI**, City of Minneapolis, Iowa and Illinois Gas Co., and most other special Agency Codes.

# TABLE OF CONTENTS

PART I - BURNER FAMILIARIZATION AND PRELIMINARY INSPECTION .....	3-6
PART II - INTRODUCTION .....	7
PART III - SUGGESTED INSTALLATION INSPECTION CHECKLIST .....	8
PART IV - GAS SYSTEMS .....	9-12
- Gas Piping Information .....	9
- Burner Gas Systems Description .....	10-12
■ "B" Gas Systems .....	10
■ "H" & "H4" Gas Systems .....	11
■ "E2" Gas Systems .....	12
PART V - OIL SYSTEMS .....	13-23
- Oil Piping Information .....	13-14
- Two Pipe Operation .....	15
- Nozzle Ratings, Simplex and Variflow .....	15
- Oil Pump Coupling .....	15
- Burner Oil Systems Description .....	16-23
■ "F1" Oil Systems (Simplex) .....	16
■ "F4B" Oil Systems (Simplex) .....	17
■ "F4S" Oil Systems (Simplex) .....	18
■ "F6R" Oil Systems (Simplex) .....	19
■ "F7" Oil Systems (Bypassing Variflow) .....	20-21
■ "F7T" Oil Systems (Three-Nozzle Bypassing Variflow) .....	22-23
PART VI - COMBUSTION CONTROLS .....	24-25
- General .....	24
■ RM7895 Flame Safeguard .....	24
■ M Series II Flame Safeguard .....	24
■ RM7800 Flame Safeguard .....	25
PART VII - BURNER ADJUSTMENTS .....	26-44
- Factory Adjustments .....	26
- Air and Fuel Adjustments Mechanisms .....	26-44
■ Primary-Secondary Air Cylinder .....	26-27
■ Air Inlet Louver .....	28
■ Air Inlet Register .....	29
■ Burner Oil Drawer Assembly .....	30
■ Gas Pilot Ignitor .....	31-32
Pilot Trouble Shooting .....	33
■ Air Flow Switch .....	34
■ Gas Pressure Regulators .....	35
■ Butterfly Gas Valve .....	35
■ Gas Pressure Switch .....	36
■ Oil Supply Pressure Regulator .....	36
■ Oil Bypass Regulating Valve .....	37
■ Oil Metering Valve .....	37
■ Low Oil Pressure Switch .....	38
■ Oil Nozzle and Ignition Electrode .....	39-43
■ Characterized Linkage (If Used) .....	44
PART VIII- BURNER START-UP .....	45-50
- General .....	45
- Flame Safeguard Installation .....	45
- Identification of Controls .....	45
- Gas Burners .....	45-47
- Oil Burners .....	48-50
PART IX - MAINTENANCE .....	51-54
- Periodic Testing Recommended Check List .....	53-54
PART X - ILLUSTRATED PARTS BREAKDOWN .....	55-59
Exploded View, Small Size Gas-Oil Burner (R6 or R8) .....	56
Exploded View, Large Size Gas-Oil Burner (R10 or R12) .....	57
Exploded View, Small Size Gas-Oil Burner (S6, S7 or S8) .....	58
Exploded View, Large Size Gas-Oil Burner (S10 or S12) .....	59
PART XI - SUPPLEMENTARY DATA .....	60

# PART I

## *R Burner*

### BURNER FAMILIARIZATION AND PRELIMINARY INSPECTION

BURNER FAMILIARIZATION - Study the following burner illustrations and determine the one which matches your unit. take special note of the PART NAMES as shown in the call-outs. Fuel Systems are described in detail in Parts IV and V.

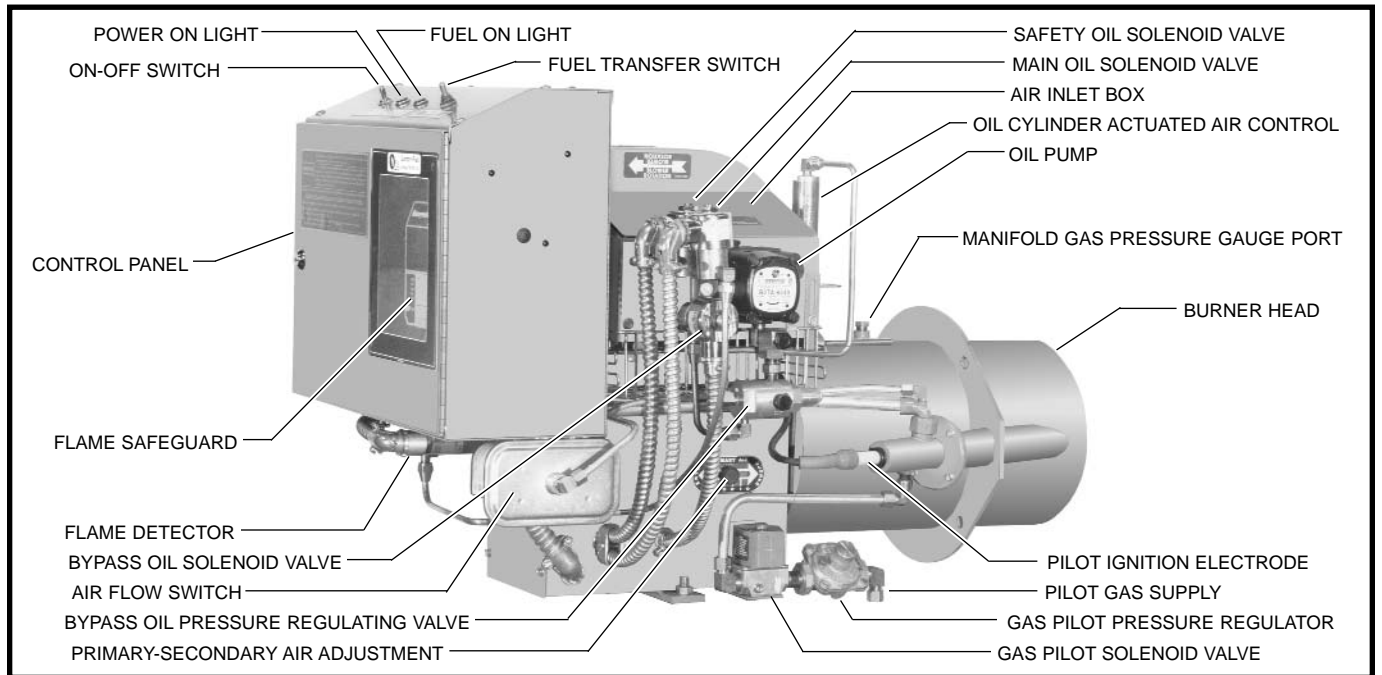

**TYPICAL MODEL R WITH B-F4B GAS-OIL SYSTEM**

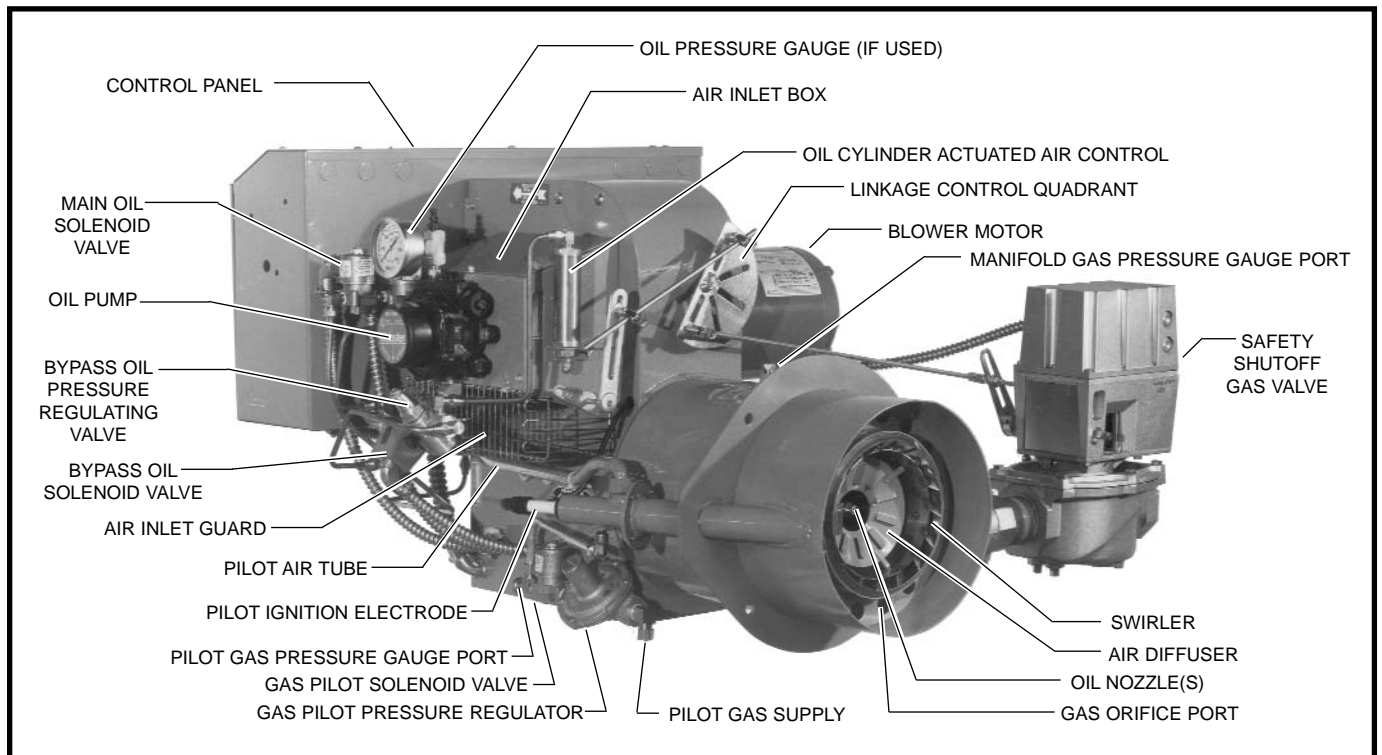

**TYPICAL MODEL R WITH H-F4S GAS-OIL SYSTEM**

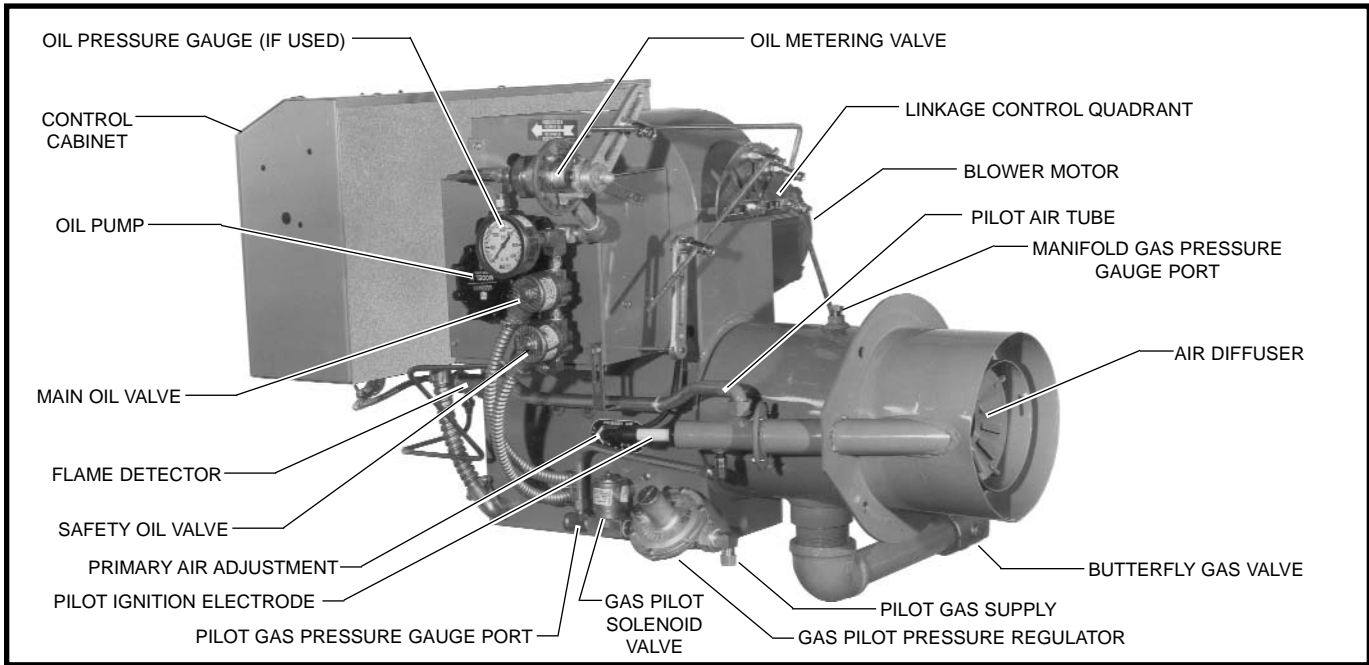

**TYPICAL MODEL R WITH E2-F6R GAS-OIL SYSTEM**

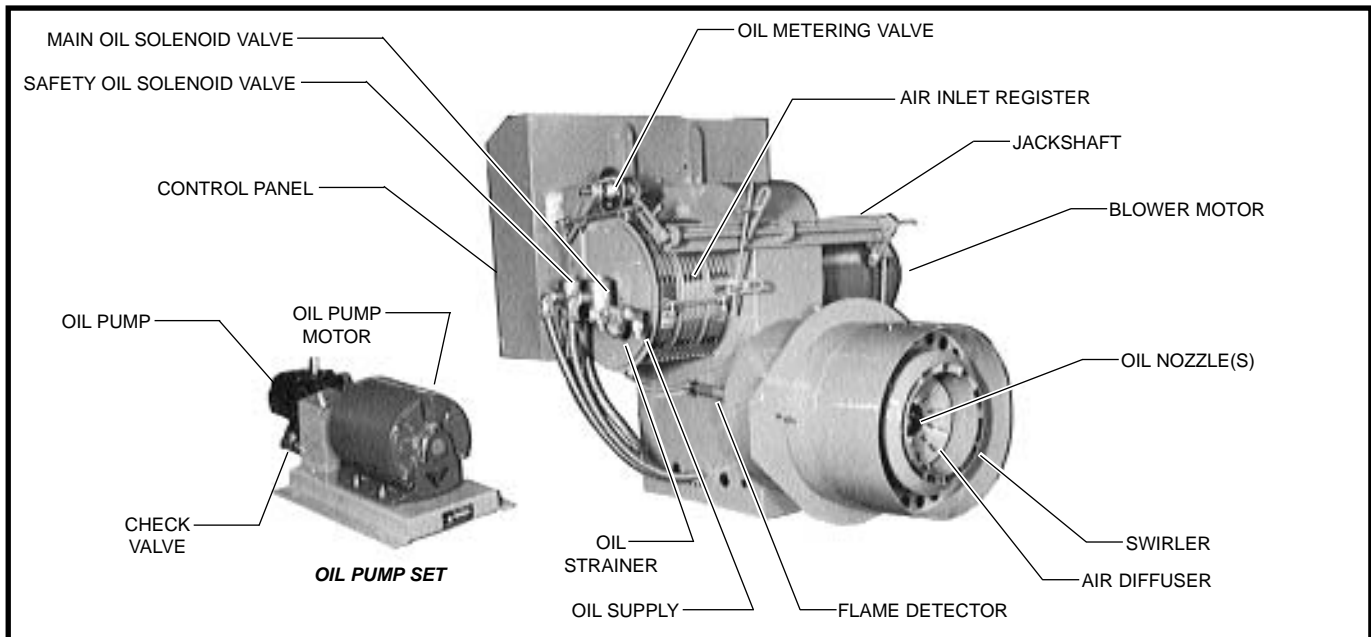

**TYPICAL MODEL R WITH F7T OIL SYSTEM**

**PRELIMINARY INSPECTION** - The burner should be visually checked for damage and loose components as these conditions can occur during shipment, through improper handling, by tampering or through improper care and storage at the job site.

**CHECK FOR:**

- Obvious damage to housing, air inlet, and components mounted thereon.
- Tightness of fasteners, tube fittings, plugs, etc.
- Tightness of electrical terminals and connections.
- Tightness of adjustment mechanisms such as ball-joint swivel connectors and control arms.
- Accumulations of oil, dust, dirt, water or other foreign matter on, in or near the burner.

# *S Burner*

## BURNER FAMILIARIZATION AND PRELIMINARY INSPECTION

BURNER FAMILIARIZATION - Study the following burner illustrations and determine the one which matches your unit. take special note of the PART NAMES as shown in the call-outs. Fuel Systems are described in detail in Parts IV and V.

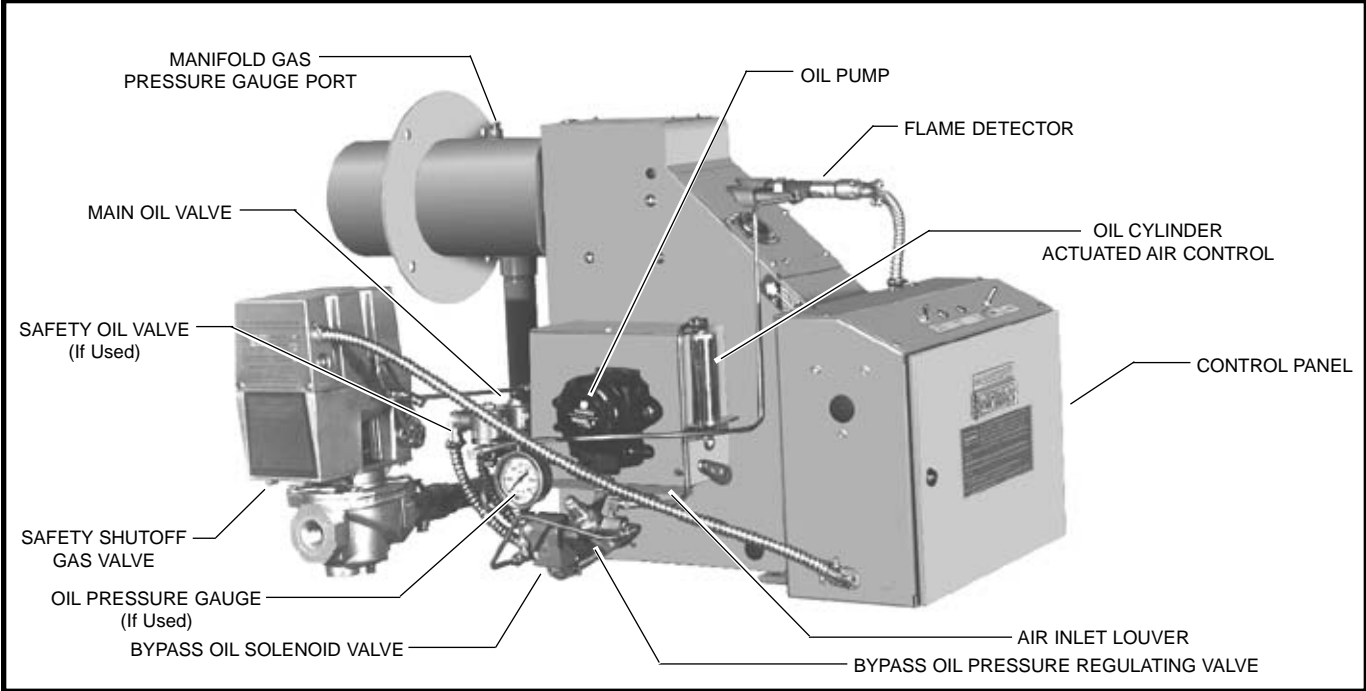

**TYPICAL MODEL S WITH H-F4S GAS-OIL SYSTEM**

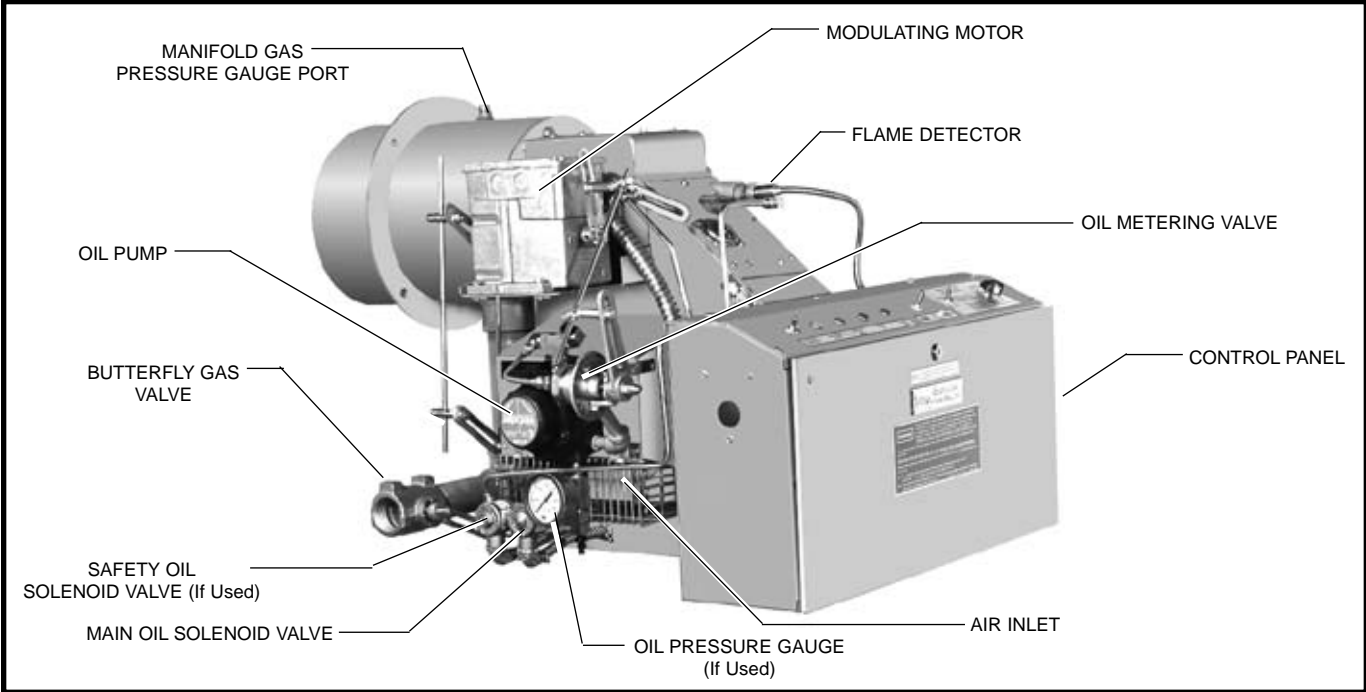

**TYPICAL MODEL S WITH E2-F6R GAS-OIL SYSTEM**

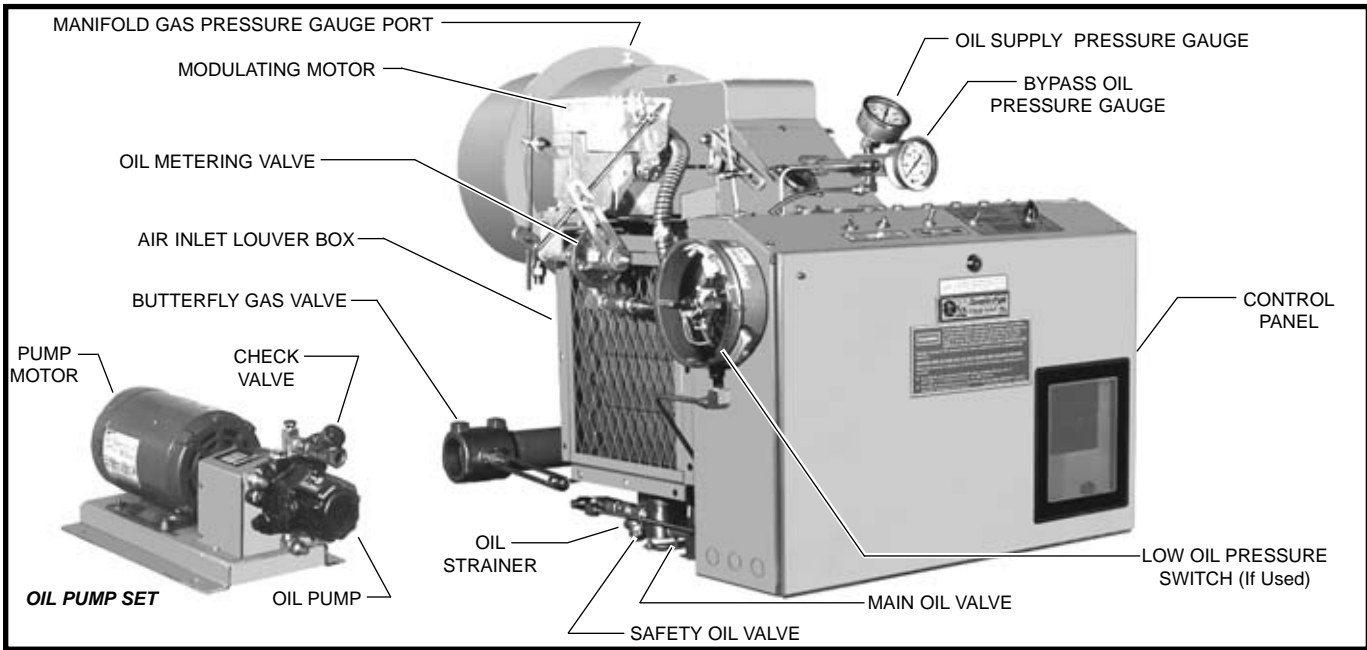

**TYPICAL MODEL S WITH E2-F7T GAS-OIL SYSTEM**

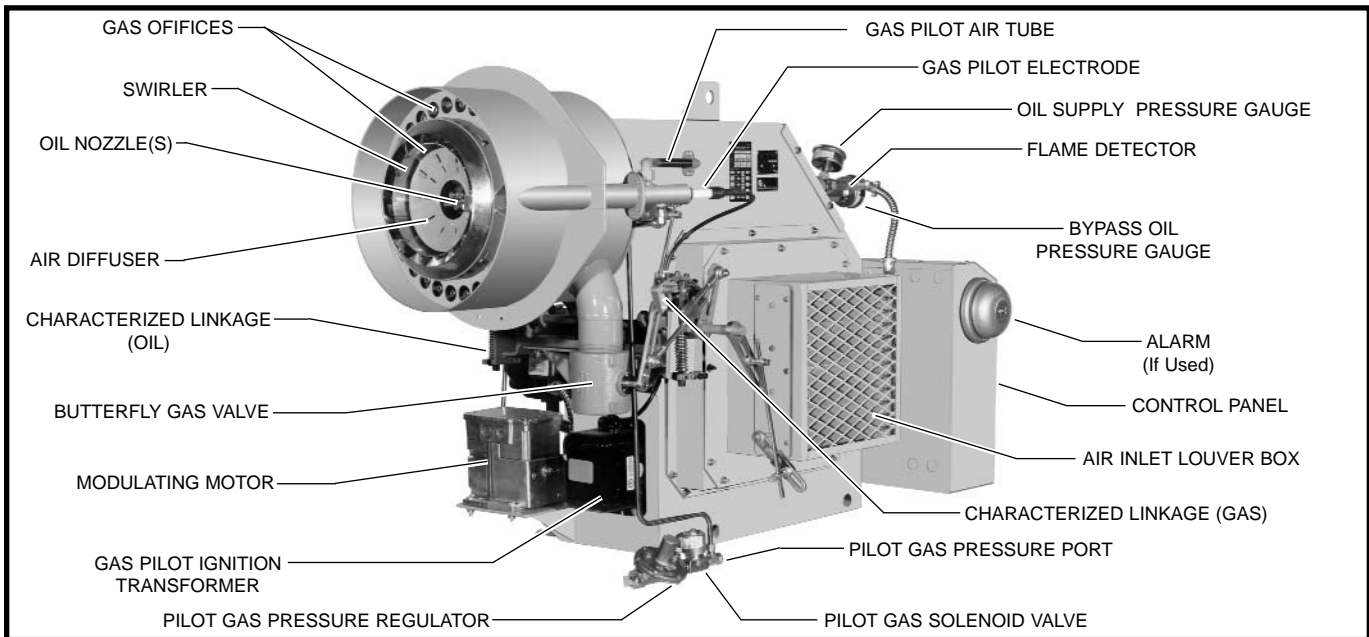

**TYPICAL MODEL S14 WITH E2-F7T GAS-OIL SYSTEM**

**PRELIMINARY INSPECTION** - The burner should be visually checked for damage and loose components as these conditions can occur during shipment, through improper handling, by tampering or through improper care and storage at the job site.

**CHECK FOR:**

- Obvious damage to housing, air inlet, and components mounted thereon.
- Tightness of fasteners, tube fittings, plugs, etc.
- Tightness of electrical terminals and connections.
- Tightness of adjustment mechanisms such as ball-joint swivel connectors and control arms.
- Accumulations of oil, dust, dirt, water or other foreign matter on, in or near the burner.

# PART II

## INTRODUCTION

### WARNINGS

If you smell gas:

1. Open windows.
2. Don't touch electrical switches.
3. Extinguish any open flame.
4. EVACUATE people from building.
5. Immediately call the gas supplier.

The use and storage of gasoline or other flammable liquids and vapors in open containers in the vicinity of this appliance is hazardous.

In accordance with OSHA standard 1910.147, all equipment, machines and processes shall be locked out prior to servicing.

If not installed, vented, operated and maintained in accordance with the manufacturer's instructions, this product could expose you to substances in fuel or from fuel combustion which can cause death or serious illness and which are known to the State of California to cause cancer, birth defects or other reproductive harm.

Improper servicing of this equipment may create a potential hazard to equipment and operators.

**SERVICING MUST BE DONE ONLY BY FULLY TRAINED AND QUALIFIED PERSONNEL.**

Before disconnecting or opening up a fuel line and before cleaning or replacing parts of any kind.

- Turn **OFF** the manual fuel shutoff valves including pilot gas cock, if applicable. If a multiple fuel burner, shut **OFF** all fuels.
- Turn **OFF** all electrical disconnects to the burner and any other equipment or systems electrically interlocked with the burner.

Do **NOT** use TEFLON TAPE or compounds with TEFLON content as an oil or gas pipe sealant. TEFLON can cause valves to fail creating a SAFETY HAZARD. Warranties are nullified and liability rests solely with the installer when evidence of TEFLON is found.

Use pipe thread sealing compound listed by Underwriters Laboratories for assembly of oil and gas piping.

The manual has been prepared to assist in the installation, operation and maintenance of your burner. It is good practice to know as much as possible about a piece of equipment before trying to install or operate it. Read the contents carefully before proceeding.

**NOTE** Installation requirements and instructions should always be covered in appropriate engineering drawings and specifications which detail the applicable building codes, etc. Information contained herein is to be used as a guide **ONLY** and not as the final authority.

## GENERAL

- Starting a burner is an event which normally culminates the efforts of several different contractors, manufacturers, utility and engineering concerns, sales and factory representatives, and others.
- In order for the burner to operate safely and meet its design capabilities, the interfacing fuel, air, electrical, exhaust and plant heating control systems must be properly sized, selected, installed and tested. Additionally, all conditions must be such that the heat generated by the burner can be safely used or wasted without endangering personnel or equipment.
- It shall be the policy of John Zink Company, LLC that no responsibility is assumed by the company nor any of its employees for any liability or damages caused by an inoperable, inadequate or unsafe burner condition which is the result, either directly or indirectly, of any of the improper or inadequate conditions described above.
- To insure that a safe and satisfactory installation has been made, a pre-start inspection is necessary. This inspection must be performed by an individual who is thoroughly familiar with all aspects of proper boiler/burner installation and how it interfaces with over all plant operation.
- Part III of this bulletin sets forth major inspection items that must be considered.

### NOTE

This inspection should be performed before the burner start-up specialist is called in. An incomplete or inadequate installation may require additional time and effort by start-up personnel and cause an untimely and costly delay.

- The results of this inspection will often times identify corrections that must be made prior to start-up as well as point out potential or long range problems plant operation if corrections are not made.
- Burner start-up is a serious matter and should not viewed as a time for "crowd gathering" by unconcerned, uninformed or unauthorized personnel. The number of persons present should be held to an absolute minimum.
- Instruction of operating and other concerned personnel should be done after the burner has been successful fired and adjusted by a qualified service agency or factory start-up specialist.



# PART III

## SUGGESTED INSTALLATION INSPECTION CHECKLIST

CHECK WHEN COMPLETED

### GENERAL

- Is burner installed in accordance with applicable installation drawings?
- If a refractory combustion chamber is part the installation, is it completely dry, cured, and ready for firing at full boiler input?
- Has the proper electrical voltage been connected to the burner control cabinet as shown on the burner material list?
- Has the burner wiring been checked for completeness and accuracy? Have 3-phase motors been properly wired and checked for correct rotation?
- Are the boiler mounted limit controls such as low water cutoffs, high limit controls, operating controls, modulating controls, etc., properly installed and wired.
- Are the boiler controls the right type and range for the installation ?
- Is the boiler water supply, including feed pumps, properly connected and is boiler filled with water?
- Is sufficient load connected to the boiler so that it can be fired continuously at full rating.
- If boiler load is not connected, can steam be wasted so that boiler can be fired continuously at full rating without endangering personnel or equipment?
- If the installation is a hot water boiler, have the circulating pumps been completely installed, wired, and tested to assure proper operation so that the burner can be fired continuously at full rating?
- For new boiler installations, has the boiler been boiled out in accordance with the boiler manufacturer's instructions ?
- Have the boiler breeching connections to the stack been completed and are they open and unobstructed?
- Is draft control equipment required and, if so, in stalled ?
- Have adequate provisions for combustion air been installed ?
- Have the persons listed below been notified of the burner start-up date?
  - Owner's Representative
  - Mechanical Contractor's Representative
  - Electrical Contractor's Representative
  - Service Organization's Representative
  - Boiler Manufacturers' Representative

- Is all specified auxiliary equipment mounted and wired? This may include outdoor temperature controls, Oil flow switches, space thermostats, water flow switches, motorized combustion air louvers, etc.

### GAS FIRING

- Are all gas train components installed and have they been properly selected, sized and assembled?
- Have properly sized vent lines been installed on all gas train components which require venting ? This includes such items as pressure regulators, normally open vent valves, diaphragm valves, low and high gas pressure switches, etc.
- Have gas train piping and components been tested and proven gas tight?
- Have the gas lines been purged?
- Is the proper gas pressure available at the inlet to the controls which meets the requirement shown on the burner material list?

### OIL FIRING

- Is the oil tank installed and filled with the proper type and grade of fuel oil as required by the burner material list? There must positively be no water in the tank!
- Is the proper oil pressure, temperature and viscosity available at the inlet to the controls which meets the requirements shown on the burner material list and/or oil system sheet?
- Have oil supply and return lines been properly sized to meet the maximum pumping capacity of the pump and has the system been purged and proven leak proof ?
- Is the oil system piped for two-pipe operation as required and is the oil pump set-up for two- pipe operation?

#### **NOTE**

Some pumps require the use of an internal bypass plug for two-pipe operation.

# PART IV

## GAS PIPING INFORMATION

### AND BURNER GAS SYSTEMS DESCRIPTION



Do NOT use teflon tape as an oil or gas pipe sealant. Teflon tape can cause valves to fail creating a safety hazard. Warranties are nullified and liability rests solely with the installer when teflon tape is used. Use a pipe joint compound rather than teflon tape.

**GAS PIPING INFORMATION** - The gas control size furnished and the minimum gas pressure required at the inlet to the controls is shown in the Burner Material List contained in the manual shipped with the burner.

Gas piping should be sized to provide the required minimum pressure at the main manual shutoff when operating at maximum input. Consult your local utility on any questions regarding gas pressure, piping pressure drops allowable and local piping requirements.

Gas piping should be installed in accordance with the American National Standard, ANSI Z223.1 and any other local codes which may apply. All gas piping should be tested after installation with air pressure or inert gas for at least three times the gas pressure that will be used. The piping ahead of the main manual shutoff shall include a full size dirt pocket or trap.

#### CAPACITY OF PIPE - NATURAL GAS (CFH)

With Pressure Drop of 0.3" w.c. and Specific Gravity of 0.60									
Pipe Length in Feet	Pipe Size - Inches (IPS)								
	1/2	3/4	1	1-1/4	1-1/2	2	1-1/2	3	4
10	132	278	520	1050	1600	3050	4800	8500	17500
20	92	190	350	730	1100	2100	3300	5900	12000
30	73	152	285	590	890	1650	2700	4700	9700
40	63	130	245	500	760	1450	2300	4100	8300
50	56	115	215	440	670	1270	2000	3600	7400
60	50	105	195	400	610	1150	1850	3250	6800
70	46	96	180	370	560	1050	1700	3000	6200
80	43	90	170	350	530	990	1600	2800	5800
90	40	84	160	320	490	930	1500	2600	5400
100	38	79	150	305	460	870	1400	2500	5100
125	34	72	130	275	410	780	1250	2200	4500
150	31	64	120	250	380	710	1130	2000	4100
175	28	59	110	225	350	650	1050	1850	3800
200	26	55	100	210	320	610	980	1700	3500

#### SPECIFIC GRAVITY OTHER THAN 0.60

Specific Gravity	Multiplier
0.50	1.10
0.60	1.00
0.70	0.926
0.80	0.867
0.90	0.817
1.00	0.775
Propane - Air	
1.10	0.740
Propane	
1.55	0.622
Butane	
2.00	0.547

#### PRESSURE DROP OTHER THAN 0.3"

Pressure Drop	Multiplier
0.1	0.577
0.2	0.815
0.3	1.00
0.4	1.16
0.6	1.42
0.8	1.64
1.0	1.83
2.0	2.58
3.0	3.16
4.0	3.65
6.0	4.47
8.0	5.15

NOTE: Use multiplier at right for other specific gravities and pressure drops.

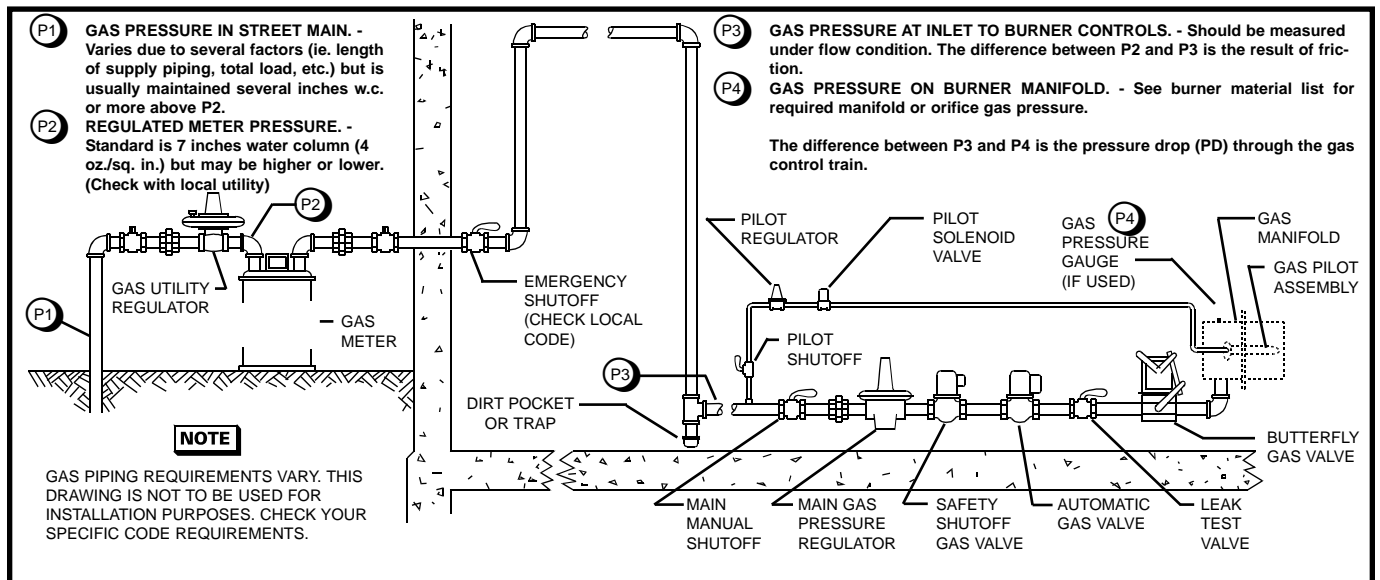

**TYPICAL GAS PIPING INSTALLATION**

GAS SYSTEMS DESCRIPTION - John Zink Company burners are supplied with **UL** listed gas trains as standard equipment. **FM, IRI, CSA** or other special Agency approved gas trains are supplied when specified.

The following schematics depict the three UL listed systems used on burners with **Input Range 400 through 2500 MBh** commonly used on **R** and **S** models. The diaphragm gas valve shown in the E system schematic may be used for this range only.

**Input Range 2501 through 5000 MBh** requires the use of low and high gas pressure switches which are added to the **H** and **E** systems.

**Input Range 5001 through 12500 MBh** requires the use of low and high gas pressure switches plus the safety shut-off valve nearest the burner must include proof-of-closure switch. These are added to the **E** system for this range.

See John Zink Company catalog sheet **1-gen-10.50** for further information.

## BURNER GAS SYSTEM DESCRIPTION

### B - GAS SYSTEM

### On-Off, Fixed Air and Fuel

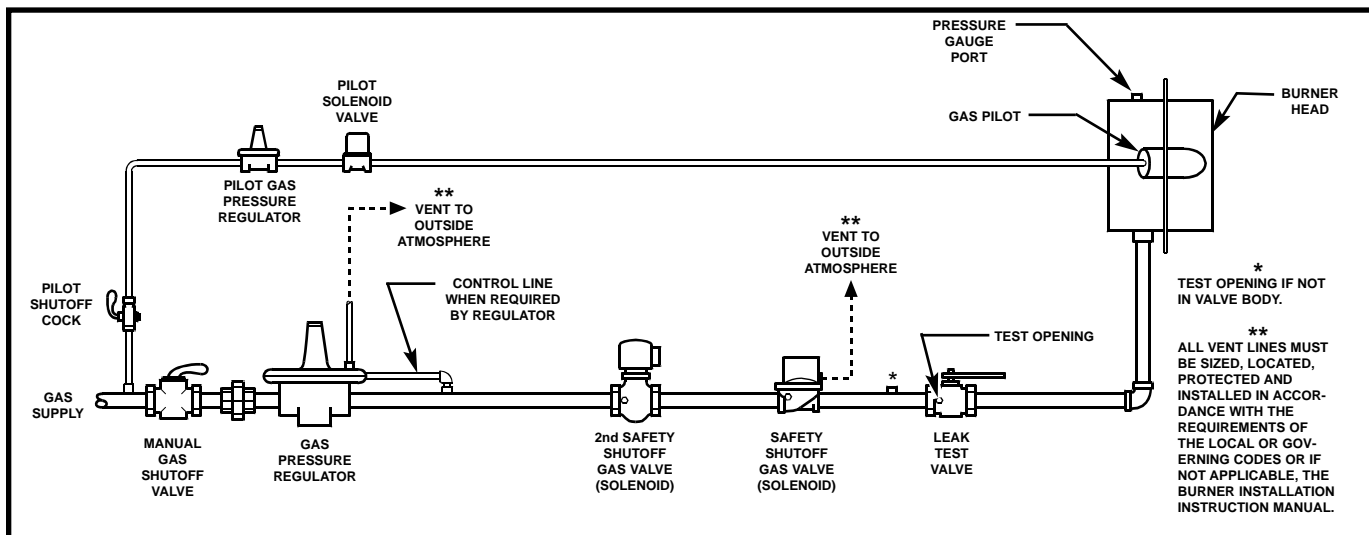

(As shown meets U. L. requirements)

**APPLICATION** - The “B” gas system is used for on-off firing. It is commonly used on burners with 400 to 2,500 MBh capacity and is used in conjunction with the “F1” or “F4B” oil systems for combination gas-oil models.

**DESCRIPTION** - The “B” system uses a slow opening diaphragm or motorized valve and a quick opening solenoid valve to control gas flow. Gas pressure is adjusted and maintained by a pressure regulator. Combustion air available to the burner is fixed in an open (high fire) position.

**OPERATING SEQUENCE** - The burner motor starts on a call for heat by the operating control and the pre-purge cycle begins.

At the end of pre-purge, the ignition transformer is energized and the pilot valve opens, igniting the gas pilot.

The flame detector proves the flame and the safety shut-off gas valves open, supplying gas to the orifices at the pressure setting required and the burner ignites.

The ignition transformer and pilot valve are de-energized.

When the operating control is satisfied, the gas valves close and the burner motor is switched off, causing the burner to shut down and await the next call for heat.

# H - GAS SYSTEM

## H4 - GAS SYSTEM

### On-Off or High-Low, Low Fire Start

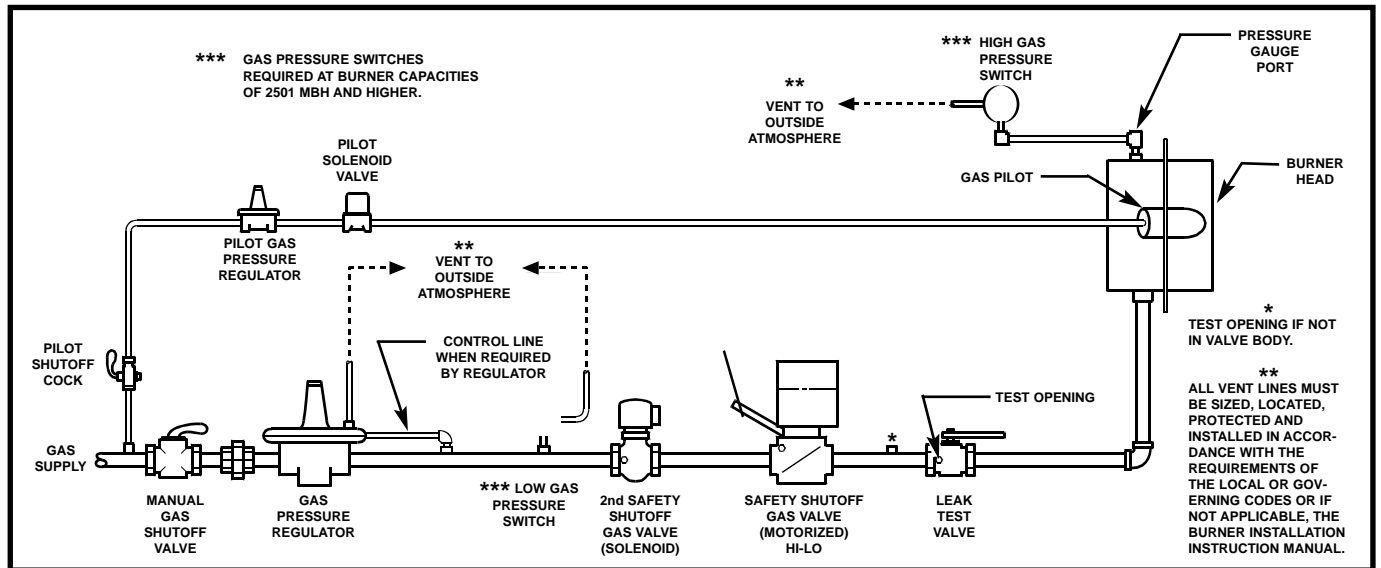

(As shown meets U. L. requirements)

**APPLICATION** - The “H” gas system is used for on-off, low fire start control in firing. It is commonly used on burners with 400 to 5,000 MBh capacity and is used in conjunction with the “F4S”, “F4V” or “F4VT” oil systems for combination gas-oil models.

**DESCRIPTION** - The “H” system uses a motorized gas valve and a quick opening solenoid gas valve arrangement to control gas flow, for “H4” systems the motorized valve changes to a hi-lo valve. Gas pressure is adjusted and maintained by a pressure regulator.

Combustion air available to the burner is controlled by connection of the air inlet louver to the motorized gas valve through a linkage arrangement.

**OPERATING SEQUENCE** - The burner motor starts on a call for heat by the operating control and the pre-purge cycle begins. The motorized valve is in the closed position, allowing low fire combustion air through the louver.

At the end of pre-purge, the ignition transformer is energized and the pilot valve opens, igniting the gas pilot.

The flame detector proves the flame and the safety shut-off gas valves open, slowly supplying gas to the orifices

at the low fire rate, and the burner ignites in the low fire position.

The ignition transformer and pilot valve are de-energized.

The motorized gas valve continues to open, allowing the linkage to drive the air louver to the full open position and the burner goes to high fire.

**HIGH-LOW OPERATION** - (H4 System only) - The high fire controller, when satisfied, drives the motorized valve to the low fire position, allowing less gas flow through the burner. Simultaneously, the air louver is closed to the low fire position. If low fire cannot maintain pressure or temperature in the boiler, the high fire controller will re-energize the motorized valve and the air louver and the burner will sequentially return to high fire.

When the operating control is satisfied, the gas valves close and the burner motor is switched off, causing the burner to shut down and await the next call for heat.

## E2 - GAS SYSTEM

## Modulating, Proven Low Fire Start

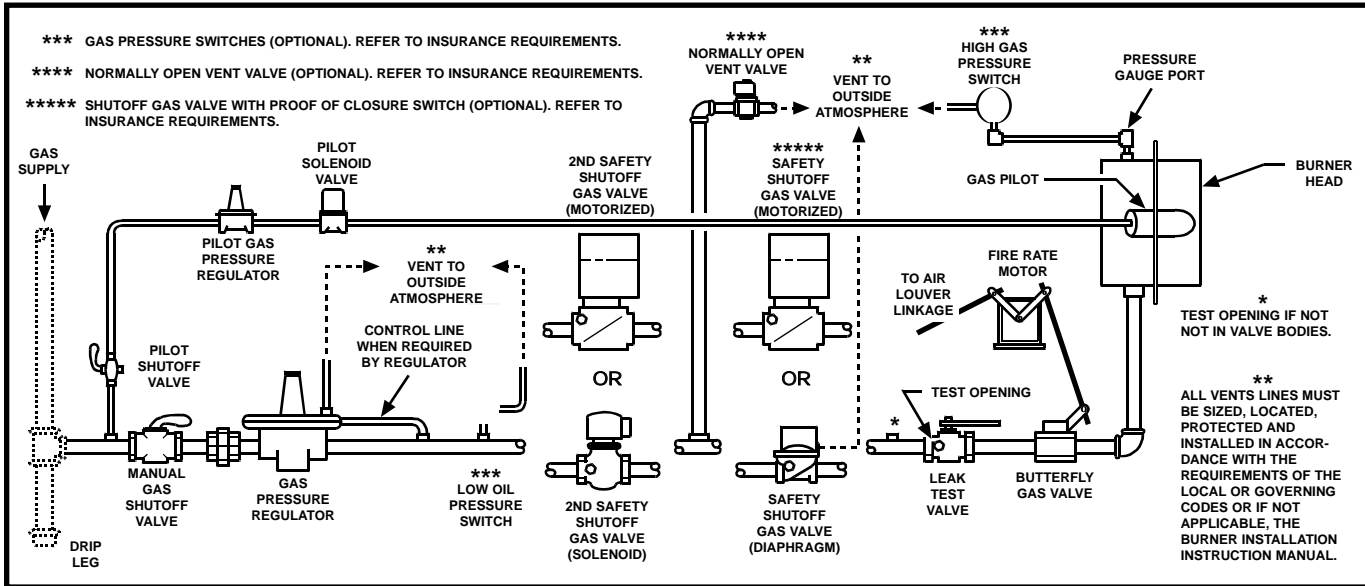

**“E2” Gas System Schematic**  
(As shown meets U.L. requirements)

**APPLICATION** - The “E2” gas system is used for modulation or high-low proven low fire start control in firing. It is commonly used on burners with 1,000 MBh and above capacity and is used in conjunction with the “F6R”, “F7” and “F7T” oil systems for combination gas-oil models.

**DESCRIPTION** - The “E2” gas system uses motorized gas valves or quick opening solenoid gas valves and a modulating motor to provide a low fire to high fire gas flow and simultaneously regulate the combustion air available to the burner. Gas pressure is adjusted and maintained by a pressure regulator. Head or orifice pressure is varied by a butterfly metering valve linked to the modulating motor. The gas butterfly metering valve is opened for high fire and gas is delivered to the orifices at the pressure setting of the pressure regulator. The air louver is also linked to the modulating motor, thus combustion air is increased proportionately as the orifice pressure increases.

**OPERATING SEQUENCE** - The burner motor starts on a call for heat by the operating control and the pre-purge cycle begins at the end of pre-purge. The air louver must be in the closed (low fire) position for the low fire guarantee switch to close and allow ignition.

At the end of pre-purge, the ignition transformer is energized and the pilot valve opens, igniting the gas pilot.

The flame detector proves the flame and the safety shutoff gas valves open, supplying gas to the orifices at the low fire setting of the butterfly metering valve and the burner ignites at the low fire rate.

The ignition transformer and pilot valve are de-energized.

After a short delay, the modulating motor is switched to the control of a potentiometer or high-low controller, which drives the motor from the low fire position toward the high fire position to match the boiler load. Since both the air inlet louver and butterfly metering valve are linked to the modulating motor, the combustion air is increased proportionately as gas increases.

As the boiler load is overcome, the potentiometer or high-low controller drives the motor back toward the low fire position. On modulating units, the burner modulates over the range between low fire and high fire in response to the boiler load.

When the operating control is satisfied, the gas valves close and the burner motor is switched off, causing the burner to shut down and await the next call for heat.

# PART V

## OIL PIPING INFORMATION AND BURNER OIL SYSTEMS DESCRIPTION

### WARNING

Do NOT use teflon tape as an oil or gas pipe sealant. Teflon tape can cause valves to fail creating a safety hazard. Warranties are nullified and liability rest solely with the installer when teflon tape is used. Use a pipe joint compound rather than teflon tape.

### CAUTION

The following information pertains to two-pipe oil systems for No. 1 or No. 2 fuel oil which can be burned without preheating. Systems designed for two-pipe operation CANNOT be used with a one-pipe system.

**OIL TANK LOCATION** - The Rules of the National Board of Fire Underwriters [Pamphlet No. 31] and local codes and regulations should be followed in locating and installing Oil Storage Tanks and Burners.

Some localities require that the tank be located below the burner level. **If any part of the tank is above the level of the burner**, an anti-siphon device must be used to prevent flow of oil in case of a break in the oil line. The illustration shows a typical installation of an outside tank which should be covered with not less than 24" of earth. A concrete anchor base is advisable to prevent shifting of buried tank during wet weather. An auxiliary oil pump is recommended if oil suction line exceeds 200 feet in length or 12 feet of lift.

**OIL PIPING** - Connections to buried tanks must be made with swing joints or copper tubing to prevent the pipes from breaking in case the tanks settle. If local requirements stipulate that iron pipe be used, swing joints made up with elbows and nipples several inches long should be used on both the suction and return lines as close to the tank as possible.

The swing joints should be made up so that they will tighten as the tank settles. Nonhardening pipe joint compounds should be used on all threaded joints.

**OIL PUMP SUCTION AND RETURN LINE SIZING** - The size of the oil suction line is dependent upon the type of oil, amount of lift, length of suction line and the suction capacity of the pump.

On single pump installations, the return line should be the same size as the suction line.

On multiple pump installations, each pump should have its own individual suction line. One return line may be used as long as it is "appropriately sized" since all pumps may share a common return line.

Refer to manufacturers' bulletins for proper line sizings.

Copper tubing should be used in preference to iron pipe, as it requires less work, is neater, has less possibility of leaks and does not scale off on the inside. Flare type fittings are recommended, as the soldered type may melt in case of fire.

The lines from the tank to the burner should be sized from data contained in the pump manufacturers specification sheet, but in NO INSTANCE should they be smaller than 1/2", O. D. copper tubing. Install tank slip fittings (Chase No. 329 or equal) in the top of the tank for both the suction and return line connections. Push both the suction and return lines down through the fittings until they touch the bottom of the tank and then pull them up three inches and lock

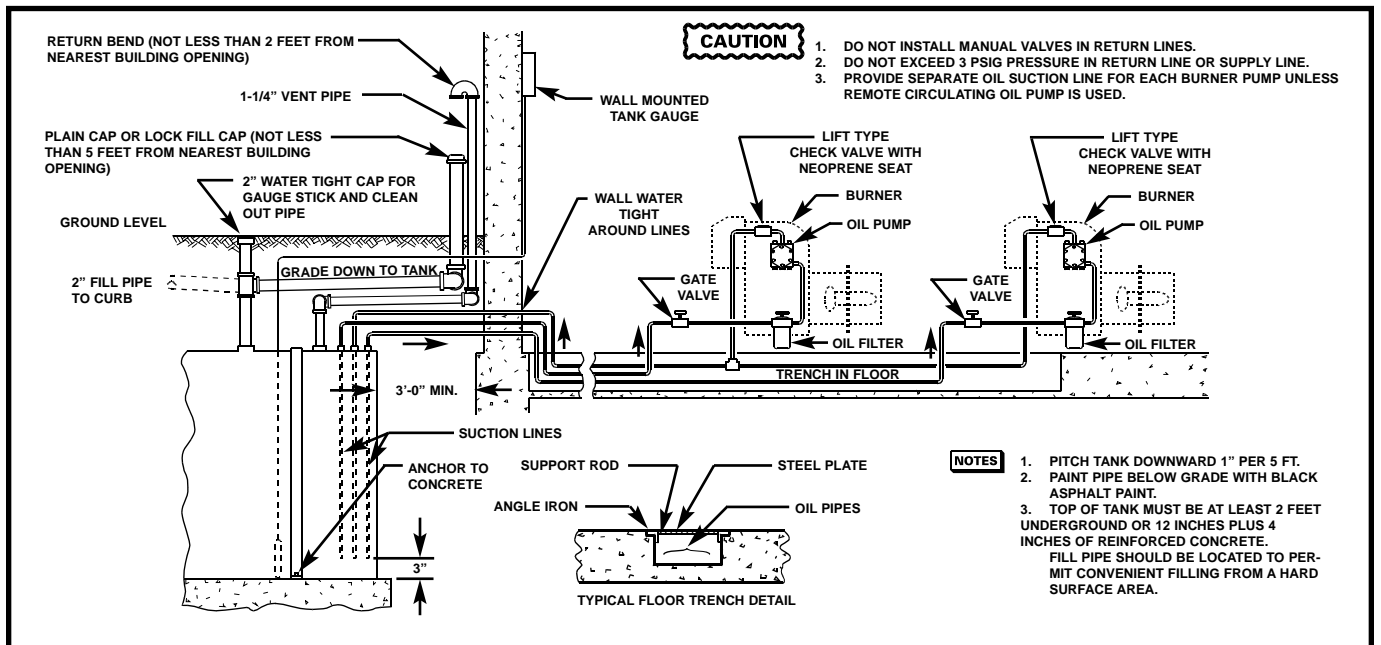

**TYPICAL OIL PIPING INSTALLATION**

in position with compression nuts so either line may be used as a suction line.

**CAUTION**

Maximum pressure allowable on suction side of pump is 3 psig.

**OIL SHUTOFF VALVE** - A hand shutoff valve should be provided in the suction line near the burner.

**NOTE**

Hand valves must not be installed on discharge side of pump or return line without a bypass relief to tank.

**CHECK VALVE AND STRAINER** - If the top of the tank is below the burner level, use a lift type check valve with neoprene seat. An oil strainer is recommended for those installations which do not have oil mumps with built-in filtering devices.

**NOTE**

Select a check valve of the soft seated type suitable for No. 2 oil, which will seat tightly with a low head.

**OIL SUCTION LINE** - Suction piping should be pitched back to the tank slightly whenever possible and particular care should be taken not to create an air trap in the line. There is always a slight amount of air in suspension in oil, and if traps are present, they will gradually fill with air, and the pump will lose its prime. Removal of air is generally very difficult.

Always provide a tee and plug in the suction line at the highest possible point to aid in priming the pump and in expelling air. Also see the pump manufacturer's instructions for priming and venting.

A two-pipe system is required for all installations. Both the suction

and return piping should be run in a trench under the floor level where possible.

**CAUTION**

Overhead suction lines should be avoided unless an auxiliary oil circulating pump set installation of the type shown below is used. Maximum standpipe height above the burner pump is 7-1/2 feet unless special devices are installed to prevent hydraulic shock from causing pump seal leakage.

**OIL TANK FILL PIPE** - The fill pipe 2" I.P.S. to the oil tank must terminate at least five feet from any window or other building opening. It should slope continuously toward the tank and be equipped with a tight-closing metal cover designed to prevent tampering. The fill pipe should terminate at least one foot above the ground to prevent flood water from seeping into the pipe. A flush type fill cap inserted in the ground should be enclosed in a water-tight well. If the fill pipe does not run vertically above the tank, it is desirable to place a tee at the tank and run a standpipe vertically so that a gauge stick may be used for measuring the oil in the tank.

**OIL TANK VENT** - The oil tank vent line should not be smaller than 1-1/4" standard weight pipe and should terminate outside of the building at a point not less than two feet measured vertically or horizontally from any window or other building opening. The top of the air vent must have a return bend or some approved cap, and it should extend above the ground high enough to prevent being obstructed by either snow or ice. In some localities, city regulations specify the height of the return bend above the ground level. All vent piping should be pitched slightly downward toward the tank. An oil gauge is recommended for all installations.

**CAUTION**

A foot valve at the end of the suction line in the tank is not recommended.

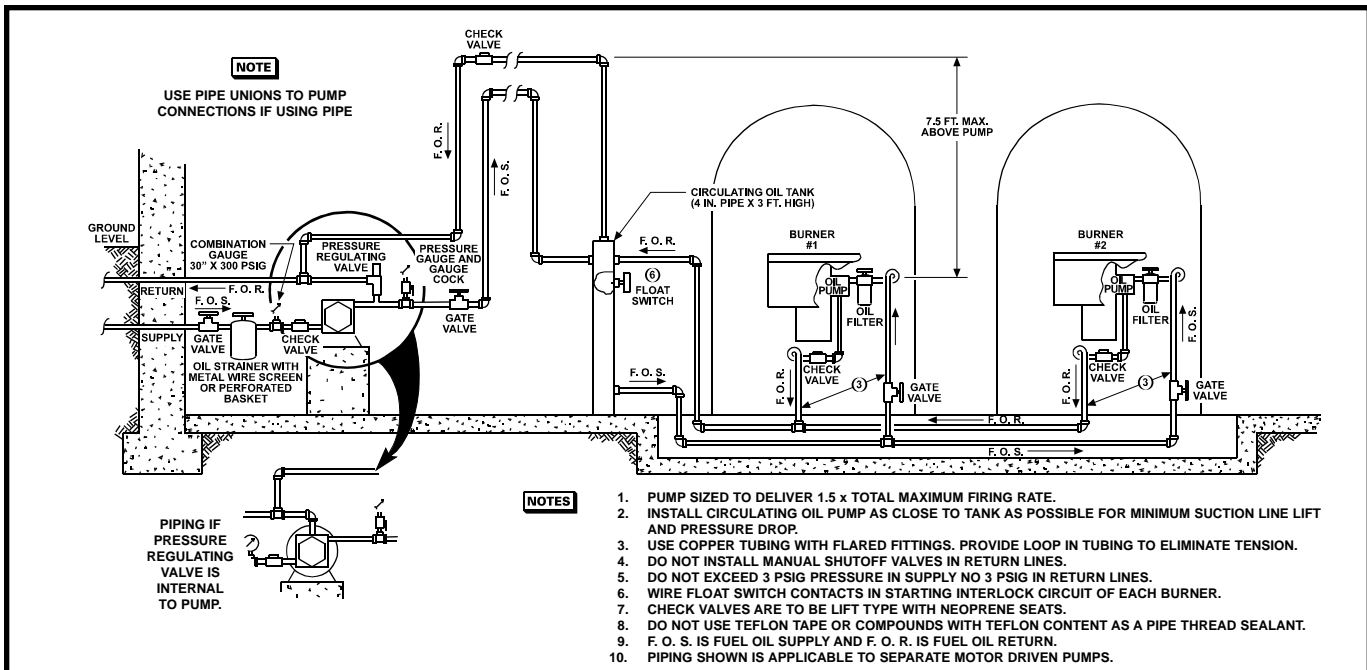

**TYPICAL REMOTE OIL CIRCULATING PUMP INSTALLATION WITH CIRCULATING OIL TANK (DAY TANK) (#2 OIL PRESSURE ATOMIZING)**

**TWO PIPE OPERATION** - The following described oil systems are designed for two-pipe operation.

**CAUTION**

If operated with a single pipe system, the motor will stall and possible damage the pump, motor and coupling.

**NOZZLE RATINGS** - The F1, F4B, F4H, F4S and F6 oil systems use a simplex type oil nozzle which is rated and stamped by the manufacturer with the GPH delivery at 100 psig.

Since these systems function at pressures well above 100 psig, the nozzle is actually delivering considerably more than the rate shown on the nozzle. Use the following chart to determine GPH flow at higher pressures.

**OIL NOZZLE CAPACITY ABOVE 100 psig**

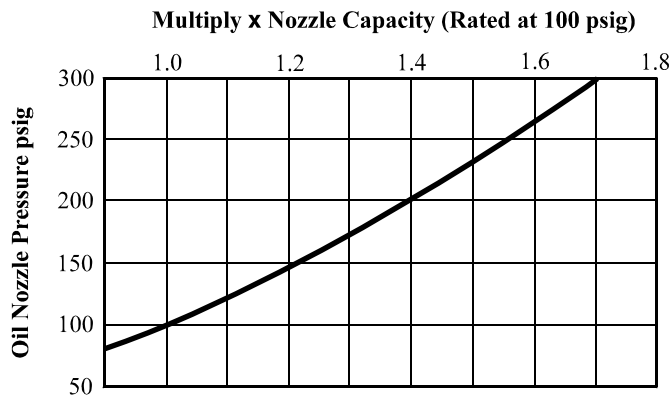

The F7 and F7T Systems use vari-flow bypassing type oil nozzles which allow for close matching of fuel-air ratios throughout the range of modulation. Supply pressure is normally maintained at 300 psig and bypass pressure is regulated to obtain the desired firing rate (GPH).

The Chart shown below gives an approximation of rated nozzle flow in relation to the bypass return line pressure. See F7 or F7T oil system bulletins for specific flow and return line pressures by nozzle part number.

**BYPASS OIL NOZZLE CAPACITY**

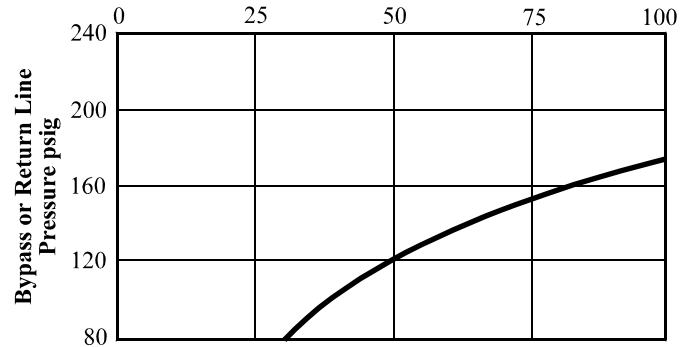

**BYPASS OIL NOZZLE**

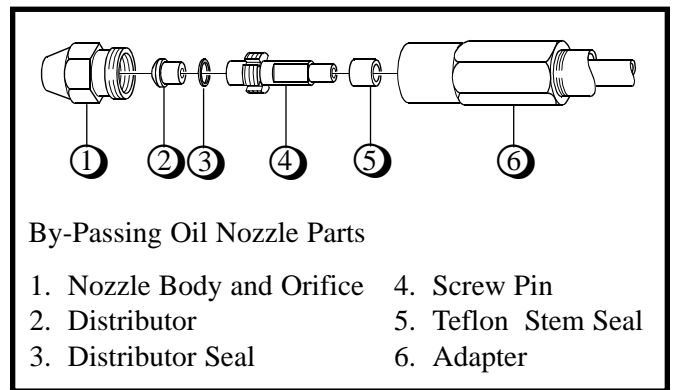

**OIL PUMP COUPLING** - The oil pump is direct driven through a flexible coupling. The coupling is a vital part of the oil system and should be periodically inspected for wear, damage and loose components. Details are shown below.

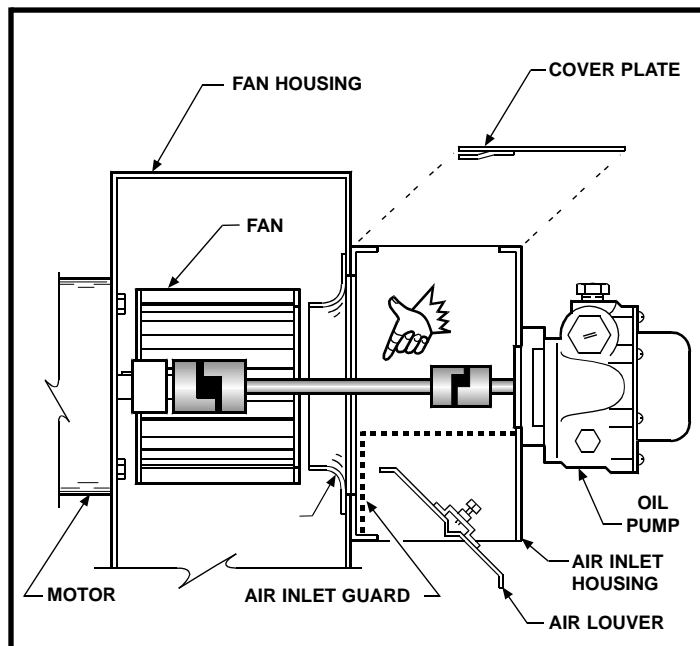

**BURNER MOUNTED PUMP**

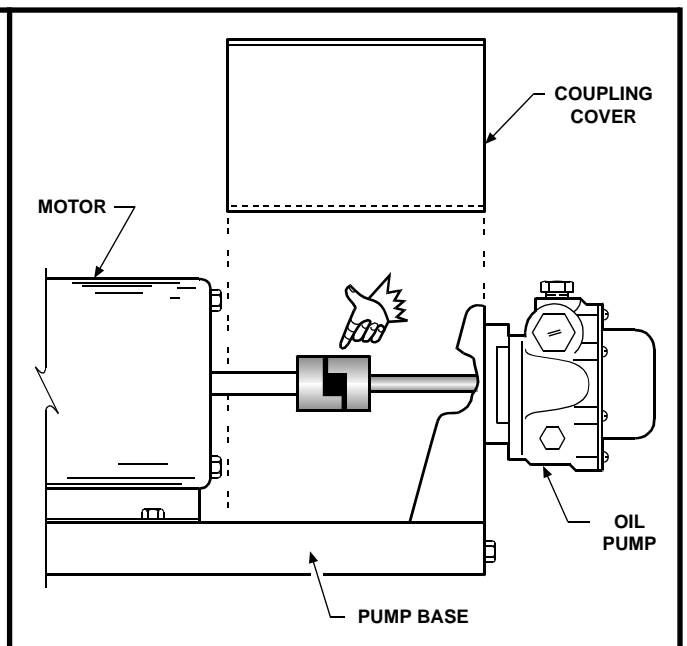

**REMOTE PUMP**



# BURNER OIL SYSTEM DESCRIPTION

## F1 OIL SYSTEM

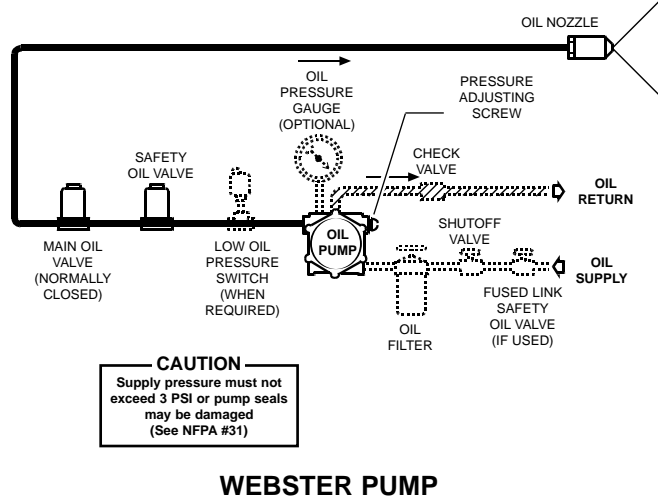
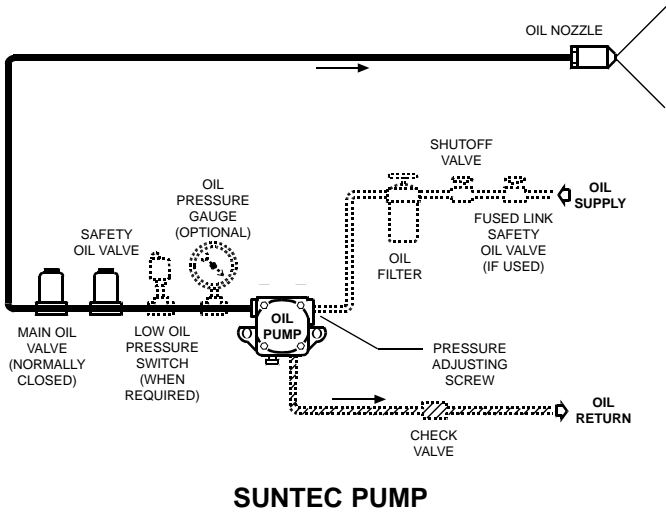

**CAUTION**  
Supply pressure must not exceed 3 PSI or pump seals may be damaged (See NFPA #31)

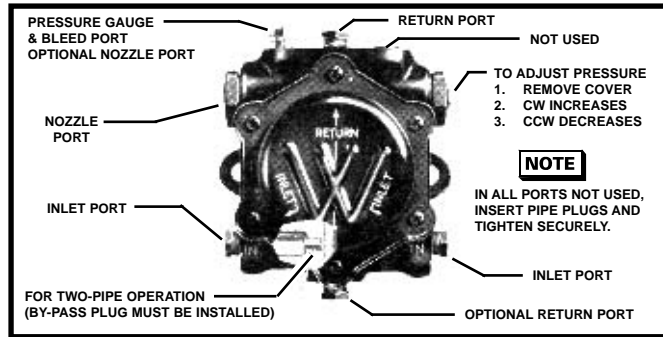
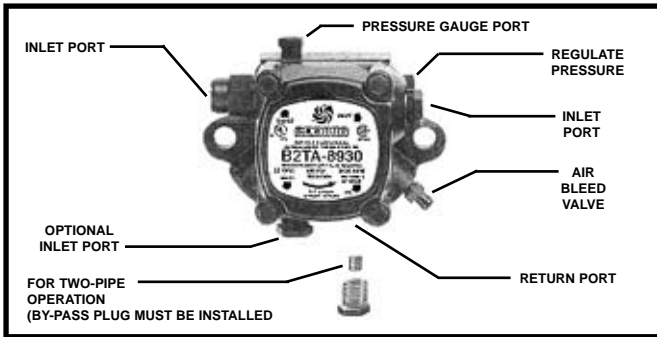

**APPLICATION** - The F1 Oil System is used for On-Off firing of No. 2 fuel oil. It is commonly used on burner with 3 to 9 GPH capacity and is used in conjunction with the “B” gas system for combination gas-oil burners.

**DESCRIPTION** - The F1 System uses a simplex type nozzle and an oil solenoid valve to control flow. Pressure is generated by an oil pump connected to the burner motor through a flexible coupling. Pump pressure is adjusted and maintained by the pump’s integral pressure regulating valve. Combustion air available to the burner is fixed in an open [high fire] position.

**OPERATING SEQUENCE** - The burner motor and oil pump start on a call for heat by the operation control

and the prepurge cycle begins. Oil is returned to the tank through the oil pump return line.

At the end of pre-purge, the ignition transformer is energized. Simultaneously, the main and safety oil solenoid valves open supplying oil to the nozzle at the pressure setting of the pump’s integral pressure regulating valve and the burner ignites.

The flame detector proves the flame and the ignition transformer is de-energized.

When the operating control is satisfied, the oil solenoid valve closes and the burner motor is switched off, causing the burner to shut down and await the next call for heat.

# F4B OIL SYSTEM

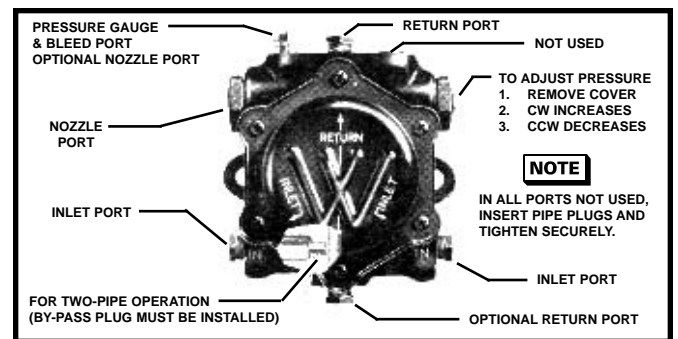
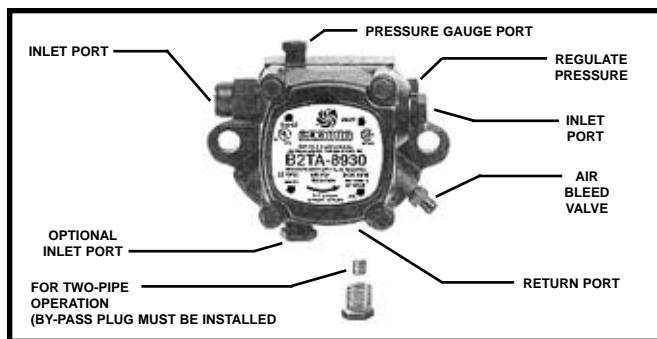
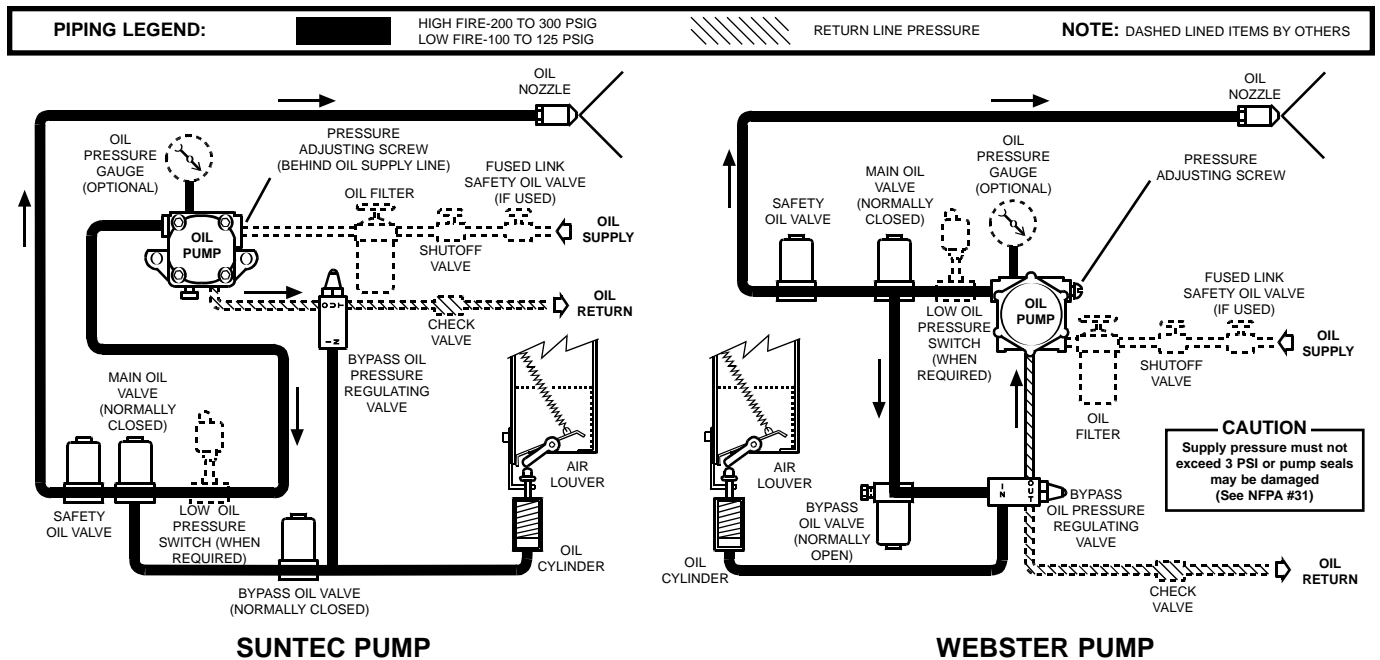

**APPLICATION** - The F4B Oil System is used for On-Off Low Fire Start control in firing No. 2 fuel oil. It is used on burners with 4 to 35 GPH capacity and is used in conjunction with the “B” gas system for combination gas-oil burners.

**DESCRIPTION** - The F4B System uses a simplex type nozzle and an oil valving arrangement to provide a low fire and a high fire oil pressure to the nozzle and simultaneously control the combustion air available to the burner through the action of an oil cylinder assembly. The burner air inlet louver is spring loaded in the full open [high fire] position. Pressure is generated by an oil pump connected to the burner motor through a flexible coupling. Pump pressure is adjusted and maintained by the pump’s integral pressure regulating valve. Low fire oil pressure is adjusted and maintained by the bypass oil pressure regulating valve.

**OPERATING SEQUENCE** - The burner motor and oil pump start on a call for heat by the operating control and the pre-purge cycle begins. The main, safety and bypass oil solenoid valves remain closed. The oil cylinder piston remains in the retracted position allowing high fire combustion air

through the louver. Oil is returned to the tank through the oil pump’s return line.

At the end of pre-purge, the pilot ignition transformer, pilot solenoid valve, and bypass oil valve are energized. When the bypass oil valve opens the oil pressure drops to the low fire setting of the bypass regulator and the oil cylinder piston extends driving the air louver closed to the low fire air setting. The pilot lights and must be proven before the main and safety fuel valves can be energized. A 5 second pilot stabilization period is provided before the main and safety valves are opened and the burner ignites. Ten seconds after the main and safety oil valves open the pilot ignition transformer, pilot solenoid valve, and bypass oil valve are de-energized.

When the bypass oil solenoid valve closes it stops the flow through the bypass pressure regulating valve thus raising the nozzle pressure to the high fire setting of the pump’s integral pressure regulating valve. When the bypass oil solenoid valve closes, the cylinder piston retracts allowing the air louver spring to pull the louver to the full open position and the burner goes to high fire.

# F4S OIL SYSTEM

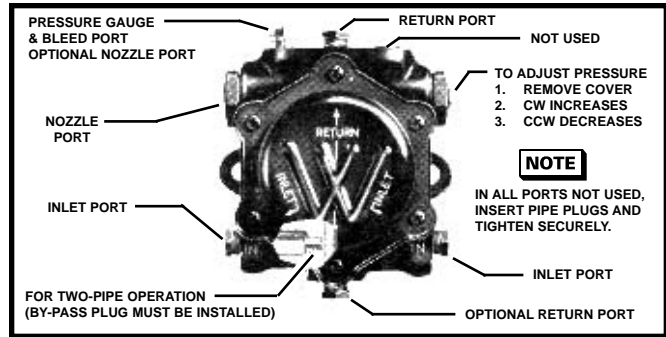
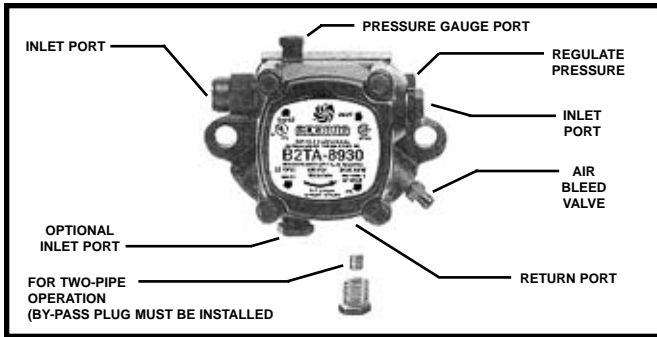
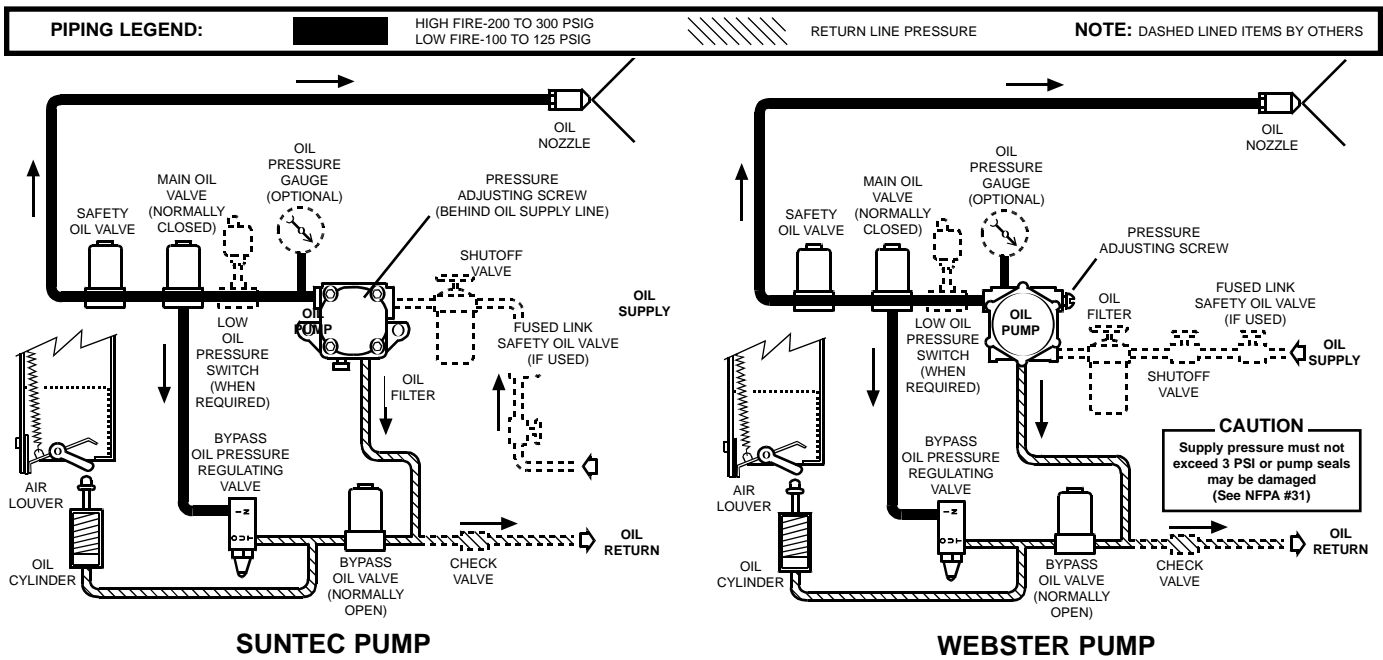

**APPLICATION** - The F4S Oil System is used for On-Off, Low Fire Start Control in firing No. 2 fuel oil. It is commonly used on burners with 4 to 34 GPH capacity and is used in conjunction with the “H” or “H4” gas systems for combination Gas-Oil models.

**DESCRIPTION** - The F4S system uses a simplex type nozzle and an oil valving arrangement to provide a low fire and a high fire oil pressure to the nozzle and simultaneously control the combustion air available to the burner through the action of an oil cylinder assembly. The burner air inlet louver is spring loaded in the closed (low fire) position. Pressure is generated by an oil pump connected to the burner motor through a flexible coupling. Pump pressure is adjusted and maintained by the pump’s integral pressure regulating valve. Low fire oil pressure is adjusted and maintained by the bypass oil pressure regulating valve.

**OPERATING SEQUENCES** - The burner motor and pump start on a call for heat by the operating control and the pre-purge cycle begins. The Normally Open bypass oil solenoid valve is open allowing oil to flow through the bypass pressure regulating valve and return to the tank. The oil cylinder piston remains in the retracted position allowing low fire combustion air through the louver.

At the end of pre-purge, the ignition transformer is energized. The main oil solenoid valve opens supplying oil to the nozzle at the low fire pressure setting of the bypass pressure regulating valve. The air inlet louver remains at the low fire position and the burner ignites at low fire rate.

The flame detector proves the flame and the ignition transformer is de-energized. After the flame is proven, the bypass oil solenoid valve closes stopping the flow through the bypass pressure regulating valve thus raising the nozzle pressure to the high fire setting of the pump’s integral pressure regulating valve. Simultaneously, this causes the oil cylinder piston to extend and drive the air louver to the high fire position and the burner goes to high fire.

**HIGH-LOW OPERATION** - On High-Low Control Systems, the High Fire Controller, when satisfied, opens the bypass oil solenoid valve allowing flow through the bypass pressure regulating valve causing the nozzle pressure to drop to the low fire setting. Simultaneously, this allows the oil cylinder piston to retract and the air louver spring pulls the louver to the low fire position. If low fire cannot maintain pressure or temperature in the boiler, the high fire controller will re-energize the bypass oil solenoid valve and the burner will sequentially return to high fire.

# F6R OIL SYSTEM

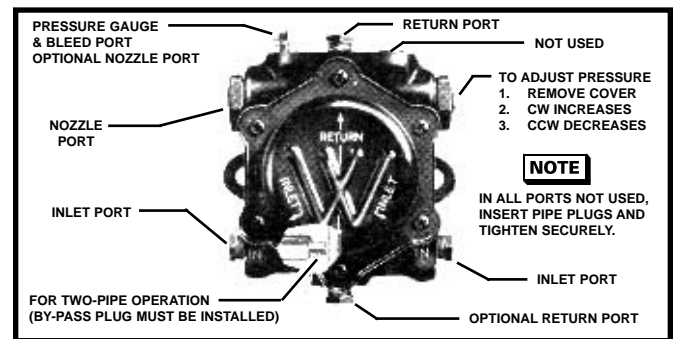
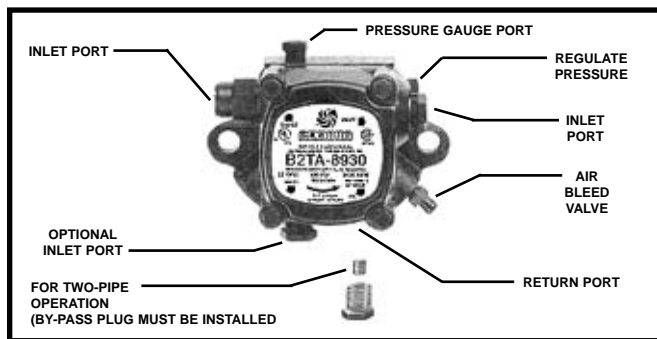
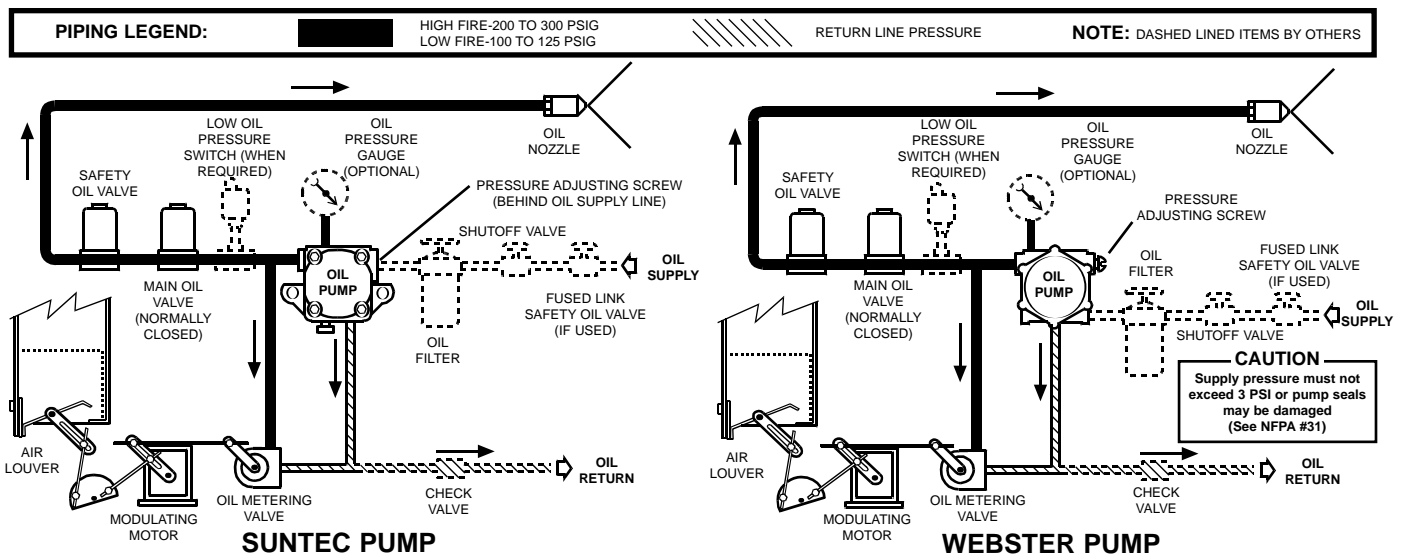

**APPLICATION** - The F6R Oil System is used for modulating or High-Low, Proven Low Fire Start Control in firing No. 2 fuel oil. It is commonly used on burners with 7 to 37 GPH capacity and is used in conjunction with the “E2” gas system for combination Gas-Oil models.

**DESCRIPTION** - The F6R Oil System uses a simplex type nozzle and a modulating or two-position (for high-low) motor to provide a low fire and a high fire oil pressure to the nozzle and simultaneously regulate the combustion air available to the burner. Pressure is generated by an oil pump connected to the burner motor through a flexible coupling or by a remote burner pump set located in close proximity to the burner. Pump pressure is adjusted and maintained by the pump’s integral pressure regulating valve. Nozzle pressure is regulated by an oil metering valve linked to the modulating motor. Oil metering valve is open for low fire, allowing more oil to return to the tank and causing nozzle pressure to drop proportionately. The oil return line is closed by the oil metering valve for high fire and oil is delivered to the nozzle at the pressure setting of the pressure regulating valve. The air louver is also linked to the modulating motor thus combustion air is increased proportionately as the nozzle pressure increases.

**OPERATING SEQUENCE (Modulating Systems)** - The burner motor and pump start on a call for heat by the operating control and the pre-purge cycle begins. Oil is returned to the tank through the oil metering valve. The air louver is in the closed (low fire) position and must remain there for the low fire guar-

antee switch to close and allow ignition to begin.

At the end of pre-purge, the ignition transformer is energized. The main oil valve opens (after proof of pilot when using gas pilot ignition of oil) supplying oil to the nozzle at the low fire pressure setting of the oil metering valve and the burner ignites at the low fire rate.

The flame detector proves the flame and the ignition transformer is de-energized or the gas pilot solenoid valve closes shutting off the gas pilot. After an short delay, the modulating motor is switched to the control of a potentiometer controller which drives the motor from the low fire position toward the high fire position to match the boiler load. Since both the air inlet louver and oil metering valve are linked to the motor, the combustion air is increased proportionately as oil nozzle pressure increases.

As the boiler load is overcome, the potentiometer controller drives the motor back toward the low fire position and the burner modulates over the range between low fire and high fire in response to the boiler load.

**HIGH-LOW OPERATION** - On High-Low Control Systems, the High Fire Controller, when satisfied, energizes the modulating motor. The motor drives the air louver and oil metering valve to the low fire position. If low fire cannot maintain pressure or temperature in the boiler, the high fire controller will re-energize the motor and the burner returns to high fire.

# F7 OIL SYSTEM

**PIPING LEGEND:**



HIGH FIRE-200 TO 300 PSIG  
LOW FIRE-100 TO 125 PSIG

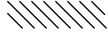

RETURN LINE PRESSURE

**NOTE:** DASHED LINED ITEMS BY OTHERS

## MECHANICAL PRESSURE ATOMIZING

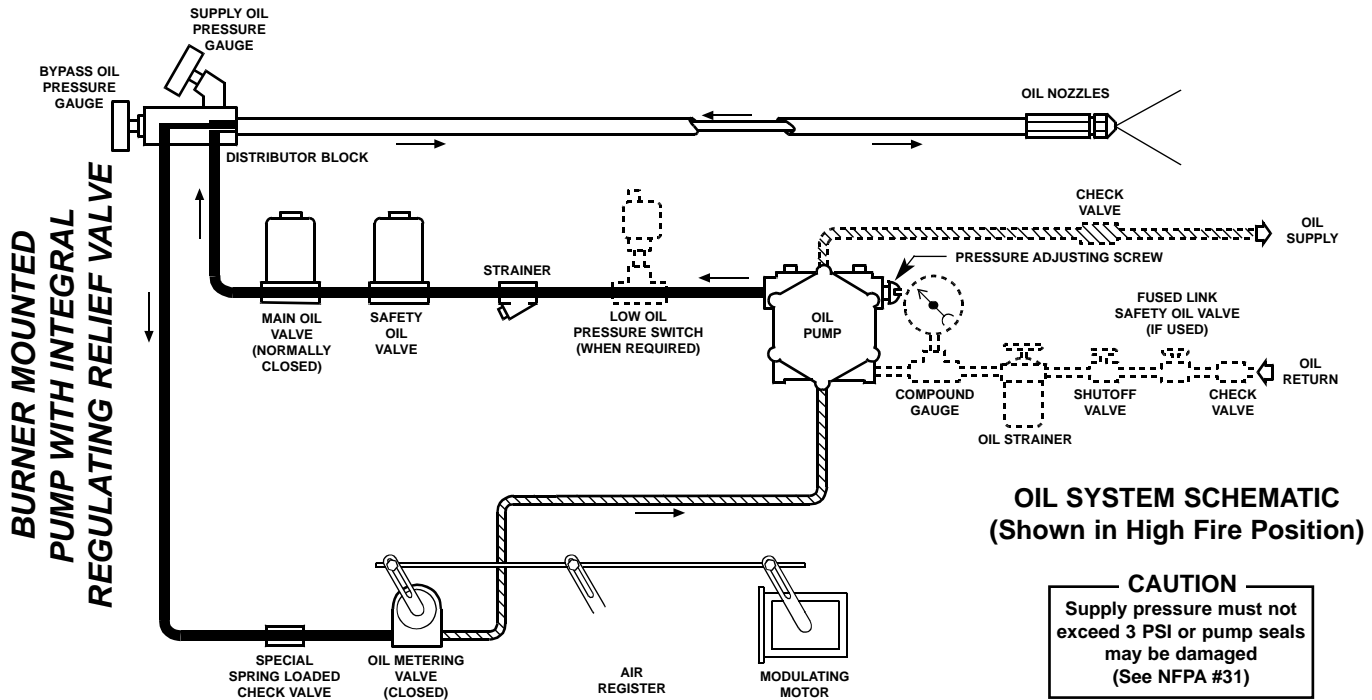
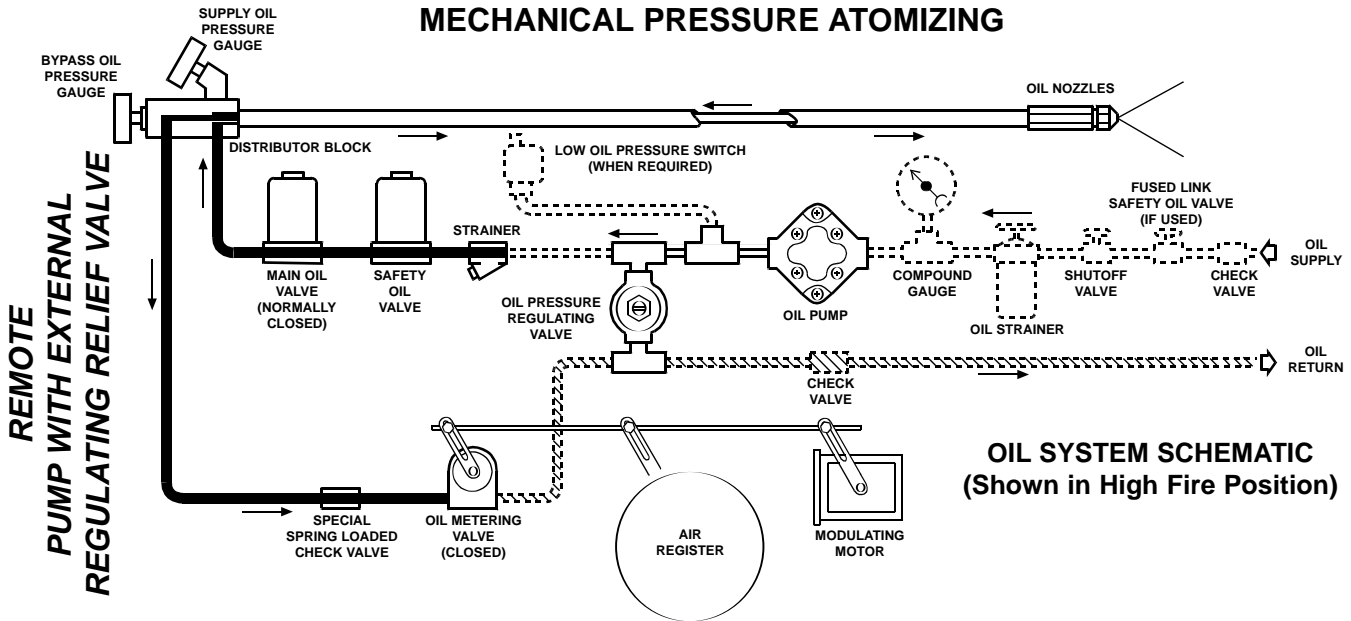

System No.	SYSTEM FUNCTION	GPH Range
F7.2	Modulating, Manual-Auto Sub-Panel, Proven Low Fire Start	20 to 225

## F7 OIL SYSTEM (cont.)

**APPLICATION** - The F7 Oil System is used for modulating or High-Low, Proven Low Fire Start Control in firing No. 2 fuel oil. It is commonly used on burners with 20 to 225 GPH capacity and is used in conjunction with the “E” gas system for combination gas-oil models.

**DESCRIPTION** - The F7 Oil System uses a bypassing type nozzle and a modulating motor to control the amount of oil available for atomization by the nozzles and simultaneously regulate the combustion air available to the burner. Pressure is generated by an oil pump connected to the burner motor through a flexible coupling or by a remote burner pump set located in close proximity to the burner. Pump pressure is adjusted and maintained by an oil pressure regulating valve. Oil flow through the nozzle is regulated by an oil metering valve in the bypass return line which is actuated by the motor. The bypass return line is closed by the oil metering valve for high fire and all the oil delivered to the nozzles is atomized into the combustion chamber. The air louver is linked to the modulating motor, thus combustion air is increased proportionately as the oil firing rate increases. A spring loaded check valve with O-Ring seat prevents oil flow back through the nozzle during the burner OFF period.

Variations as shown in the following tabulation are normally made between small and large GPH burners.

Item	Small Units	Large Units
Integral Pump Pressure Reg. Valve	X	
Separate Pressure Regulating Valve		X
Burner Mounted Oil Pump	X	
Separate Oil Pump Set		X

**OPERATING SEQUENCE [Modulating Systems]** - The burner motor and pump start on a call for heat by the operating control and the pre-purge cycle begins.

For smaller burners, the oil is returned to the tank through the pump return line. For larger units, the oil is returned to the tank by way of the separate pressure regulating valve. The air louver is in the closed [low fire] position and must remain there for the low fire guarantee switch to close and allow ignition at the end of pre-purge.

At the end of pre-purge, the gas pilot ignition transformer is energized, the gas pilot solenoid valve opens and the pilot ignites. After proof of pilot by the combustion control, the main and safety oil solenoid valves open supplying oil to the nozzle at the low fire pressure setting of the oil metering valve and the burner ignites at low fire rate.

The flame detector proves the flame and the gas pilot solenoid valve closes shutting off the gas pilot. After a short delay, the modulating motor is switched to the control of a potentiometer controller which drives the motor from the low fire position toward high fire position to match the boiler load. With air louver and oil metering valve linked to the motor, the combustion air is increased proportionately as the oil firing rate increases.

As the boiler load is overcome, the potentiometer controller drives the motor back toward the low fire position and the burner modulates over the range between low fire and high fire in response to the boiler load.

**HIGH-LOW OPERATION** - On high-low control systems, the high fire controller, when satisfied, energizes the modulating motor. The motor drives the air louver and oil metering valve to the low fire position. [Air louver closed, oil metering valve open allowing more oil to return to the tank and causing the amount of oil available for atomization to drop proportionately.] If low fire cannot maintain pressure or temperature in the boiler, the high fire controller will re-energize the modulating motor and burner returns to high fire.

# F7T OIL SYSTEM

**PIPING LEGEND:**  HIGH FIRE-200 TO 300 PSIG  
 LOW FIRE-100 TO 125 PSIG  
 RETURN LINE PRESSURE

**NOTE:** DASHED LINED ITEMS BY OTHERS

## MECHANICAL PRESSURE ATOMIZING

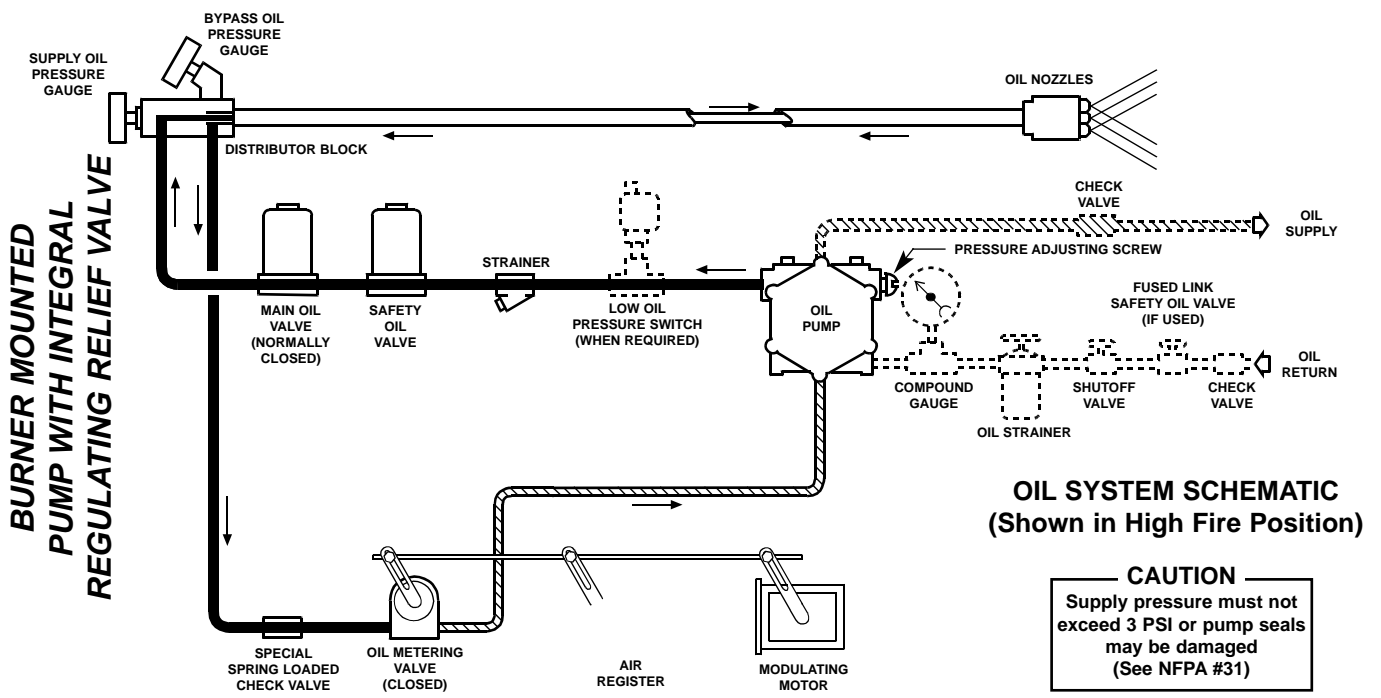
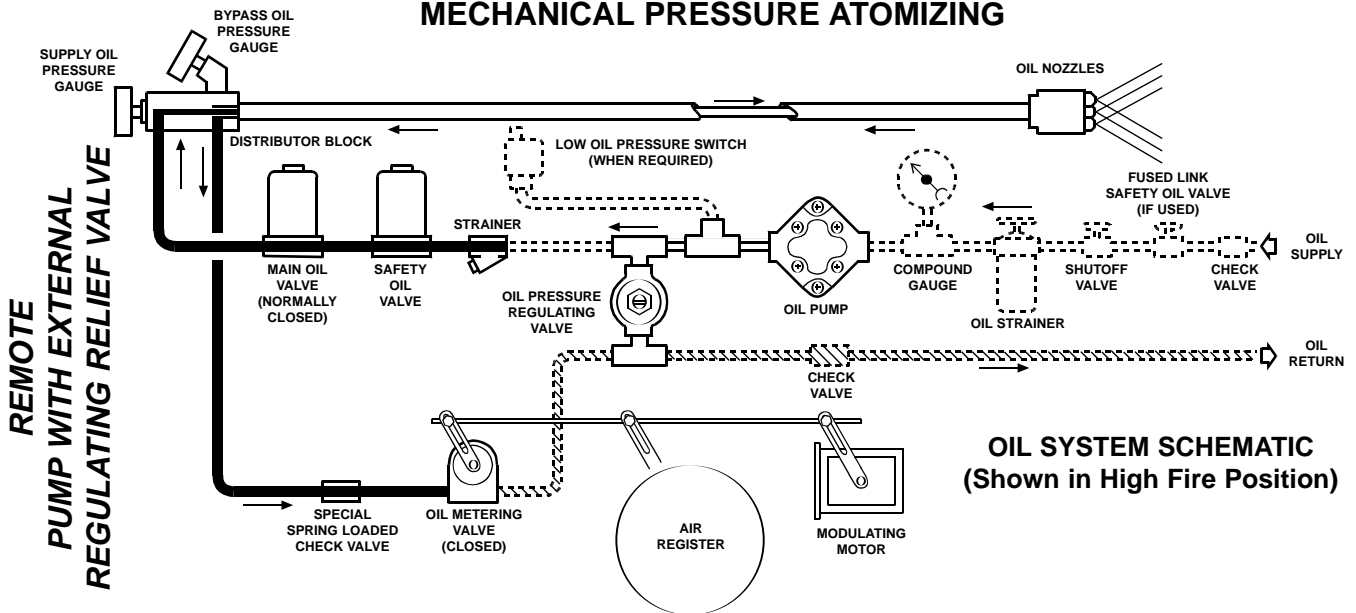

System No.	SYSTEM FUNCTION	GPH Range
F7T.2	Modulating, Manual-Auto Sub-Panel, Proven Low Fire Start	20 to 120

## F7T OIL SYSTEM (cont.)

**APPLICATION** - The F7T Oil System is used for modulating or High-Low, Proven Low Fire Start Control in firing No. 2 fuel oil. It is commonly used in conjunction with the "E" gas system for combination gas-oil models.

**DESCRIPTION** - The F7T Oil System uses bypassing type nozzles and a modulating motor to control the amount of oil available for atomization by the nozzles and simultaneously regulate the combustion air available to the burner. Pressure is generated by an oil pump connected to the burner motor through a flexible coupling or by a remote burner pump set located in close proximity to the burner. Pump pressure is adjusted and maintained by an oil pressure regulating valve. Oil flow through the nozzles is regulated by an oil metering valve in the bypass return line which is actuated by the motor. The bypass return line is closed by the oil metering valve for high fire and all the oil delivered to the nozzles is atomized into the combustion chamber. The air louver is linked to the modulating motor, thus combustion air is increased proportionately as the oil firing rate increases. A spring loaded check valve with O-Ring seat prevents oil flow back through the nozzle during the burner OFF period.

Variations as shown in the following tabulation are normally made between small and large GPH burners.

Item	Small Units	Large Units
Integral Pump Pressure Reg. Valve	X	
Separate Pressure Regulating Valve		X
Burner Mounted Oil Pump	X	
Separate Oil Pump Set		X

**OPERATING SEQUENCE [Modulating Systems]** - The burner motor and pump start on a call for heat by the operating control and the pre-purge cycle begins.

For smaller burners, the oil is returned to the tank through the pump return line. For larger units, the oil is returned to the tank by way of the separate pressure regulating valve. The air louver is in the closed [low fire] position and must remain there for the low fire guarantee switch to close and allow ignition at the end of pre-purge.

At the end of pre-purge, the gas pilot ignition transformer is energized, the gas pilot solenoid valve opens and the pilot ignites. After proof of pilot by the combustion control, the main and safety oil solenoid valves open supplying oil to the nozzle at the low fire pressure setting of the oil metering valve and the burner ignites at low fire rate.

The flame detector proves the flame and the gas pilot solenoid valve closes shutting off the gas pilot. After a short delay, the modulating motor is switched to the control of a potentiometer controller which drives the motor from the low fire position toward high fire position to match the boiler load. With air louver and oil metering valve linked to the motor, the combustion air is increased proportionately as the oil firing rate increases.

As the boiler load is overcome, the potentiometer controller drives the motor back toward the low fire position and the burner modulates over the range between low fire and high fire in response to the boiler load.

**HIGH-LOW OPERATION** - On high-low control systems, the high fire controller, when satisfied, energizes the modulating motor. The motor drives the air louver and oil metering valve to the low fire position. [Air louver closed, oil metering valve open allowing more oil to return to the tank and causing the amount of oil available for atomization to drop proportionately.] If low fire cannot maintain pressure or temperature in the boiler, the high fire controller will re-energize the modulating motor and burner returns to high fire.



# PART VI

## COMBUSTION CONTROLS

**GENERAL** - Different control systems are available to satisfy different needs. The most commonly used systems are briefly described in this part to outline the functional characteristics of the various flame safeguards. For further information, consult the specific bulletin covering the flame safeguard used in your burner.

### NOTE

Wiring diagrams and operating sequences are prepared for each **INDIVIDUAL** burner unit. These are furnished as part of the the engineering documentation included as supplementary data to the instructions manual **SHIPPED WITH THE BURNER**.

#### RM7895 FLAME SAFEGUARD

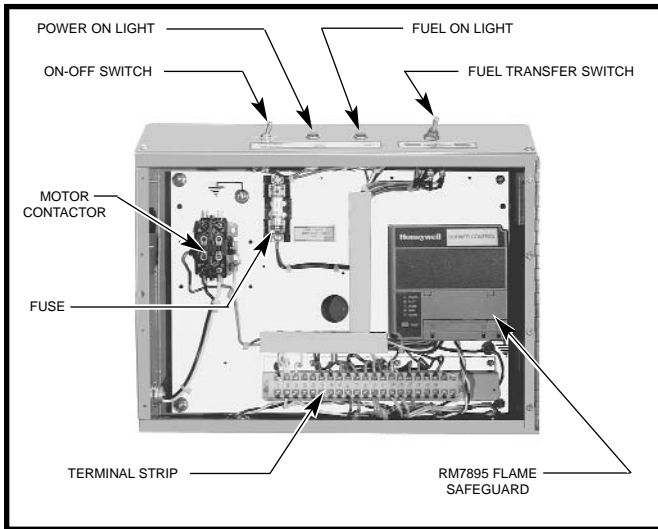

**TYPICAL RM7895 CONTROL PANEL**

#### M SERIES II FLAME SAFEGUARD

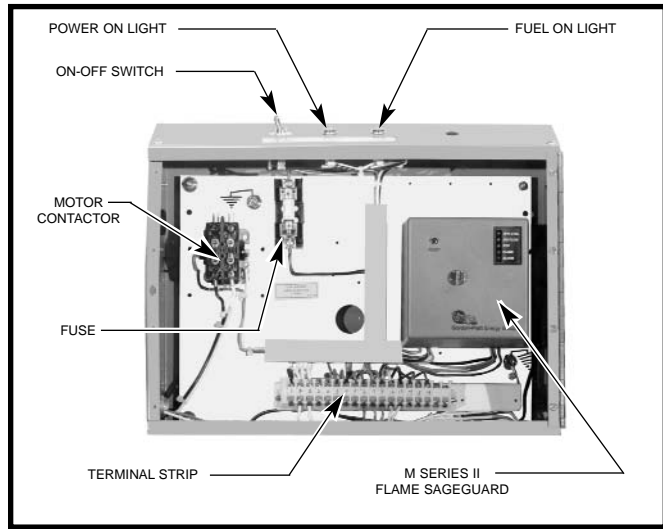

**TYPICAL M SERIES II CONTROL PANEL**

The RM7895 flame safeguard control provides flame-out protection plus automatic sequencing of the burner motor, pilot valve, ignition spark, and main fuel valve on gas, oil, or combination gas-oil.

A plug in solid state timer in the RM7895 provides pre-purge timing.

The M Series II flame safeguard provides flame-out protection as well as automatic sequencing of burner motor, pilot valve, ignition spark and main fuel valve on gas, oil, or combination gas-oil burners.

A selection of solid-state, interchangeable plug-in amplifiers allows the M Series II to be used with rectifying, infrared or ultraviolet flame detectors.

## RM7800 FLAME SAFEGUARD

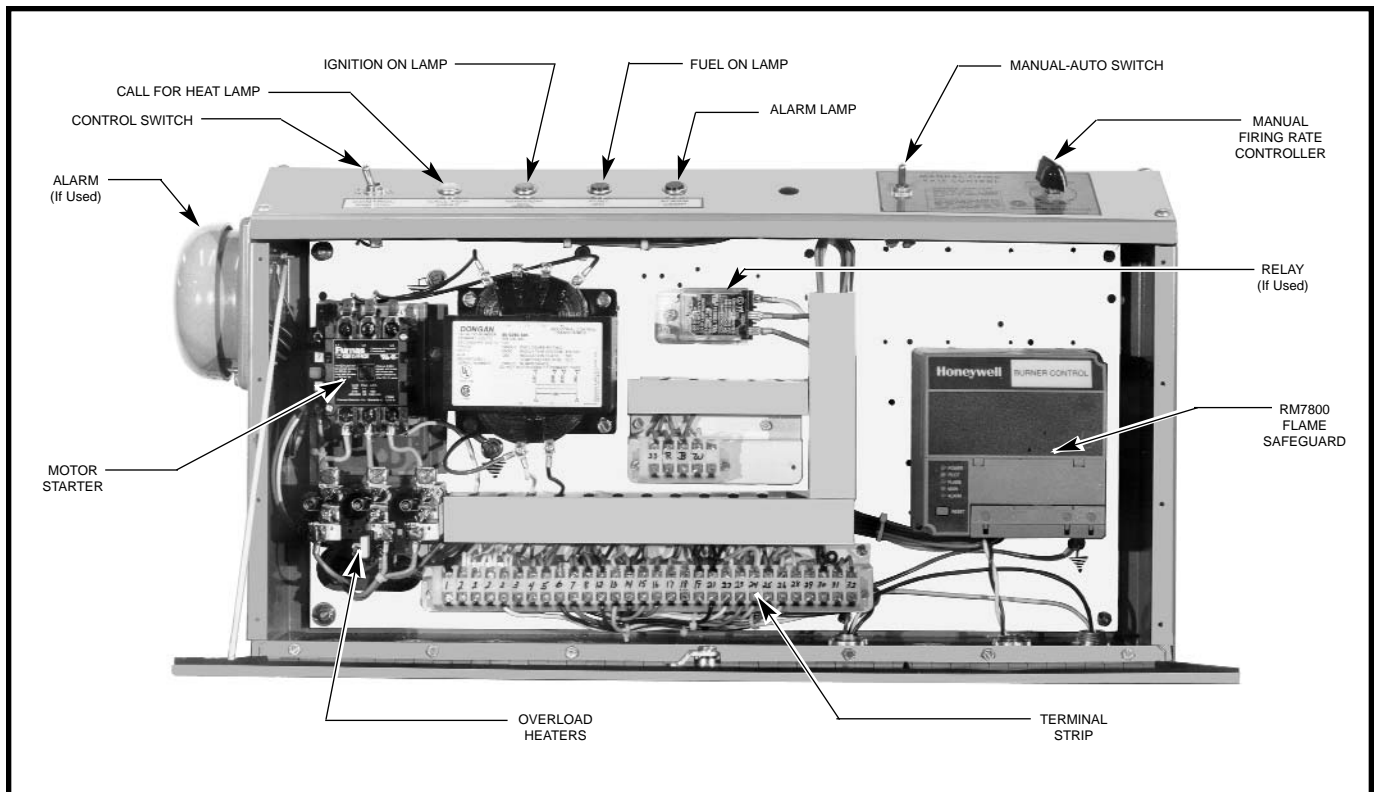

**TYPICAL RM7800 CONTROL CABINET**

The RM7800 flame safeguard control provides flame-out protection plus automatic sequencing of burner motor, firing rate motor, pilot valve, ignition spark, and main fuel valve on gas, oil, or combination gas-oil burners.

A selection of color-coded, solid-state, interchangeable plug-in amplifiers allows the RM7800 to be used with rectifying, infrared, or ultraviolet flame detectors.

# PART VII

## BURNER ADJUSTMENT

**FACTORY ADJUSTMENTS** - The burner is adjusted at the factory to meet “dry run” conditions. Adjustments and initial settings must be checked prior to initial light-off and settings must be verified by combustion tests.

### CAUTION

Do not set fire visually on forced draft burners. Instruments are the only safe and reliable means to determine the proper adjustments.

**AIR AND FUEL ADJUSTMENT MECHANISMS** - Various adjustment mechanisms control the air and fuel available for combustion. These will vary by the type fuel to be burned and the method used to control the air-fuel ratio.

Illustrations which follow show the items which are subject to adjustment. Determine the applicability of each illustration to your burner, then proceed to familiarize yourself with how the item functions. Where a setting is indicated, verify the setting or make preliminary adjustments as necessary to facilitate initial start-up.

## BURNER AIR AND FUEL ADJUSTMENTS

Items 1 thru 15

### CAUTION

Adjustable linkage mechanisms which are driven by an actuator [such as a modulating motor or motorized gas valve] must be adjusted while the actuator’s arm is in the 0° travel position.

### Item 1A

### ADJUSTMENT OF PRIMARY-SECONDARY AIR CYLINDER [Manual type]

#### DESCRIPTION

A separate air adjustment at the firing head provides a unique air control system enabling quiet, stable combustion without objectional noise or pulsation. This feature allows flexibility in adapting to a variety of job conditions and insures greater combustion efficiency.

#### ADJUSTMENT PROCEDURE

1. Loosen positioning control knob.
2. For initial start-up, position knob midway in the adjustment slot, then tighten against indicator scale.

#### NOTE

If positioned too far forward, the main flame may pulsate. If too far to the rear, the surplus air may cause noisy operation.

#### TYPICAL GAS-OIL BURNER HEAD

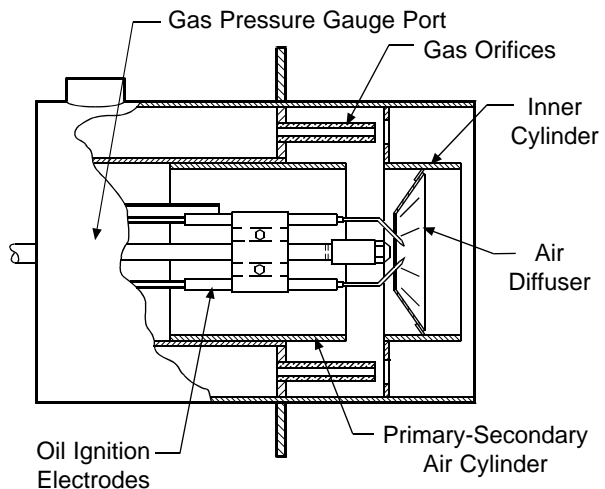

Positioning Control Knob located on side of Housing

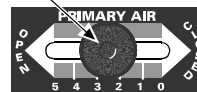

**DESCRIPTION**

A separate air adjustment at the firing head provides a unique air control system enabling quiet, stable combustion without objectional noise or pulsation. This feature allows flexibility in adapting to a variety of job conditions and insures greater combustion efficiency.

**ADJUSTMENT PROCEDURE**

**CAUTION**

Knobs must be free to travel in horizontal slots when burner modulates.

1. For initial start-up, indicator knobs will be set at 0 for low fire and 2.5 to 3 for high fire.
2. Position ball-joint connectors to obtain desired travel for low fire and high fire. [See diagram below]

**NOTE**

If the primary air sleeve is too far forward at high fire, the flame will blow off the head or will pulsate and if it is too far back, the burner will have a high pitched noise.

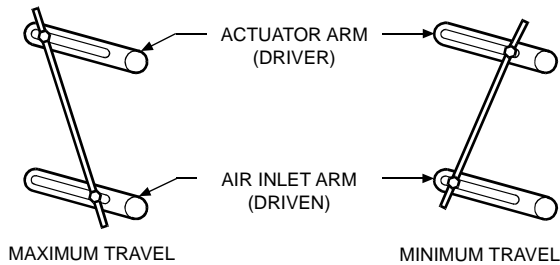

**TYPICAL PRIMARY-SECONDARY AIR CYLINDER CONTROL FOR MODEL "S"**

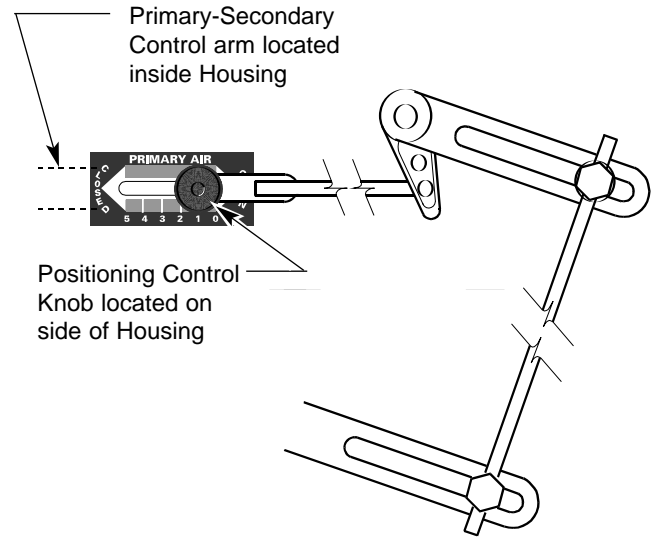

**TYPICAL PRIMARY-SECONDARY AIR CYLINDER CONTROL FOR MODEL "R"**

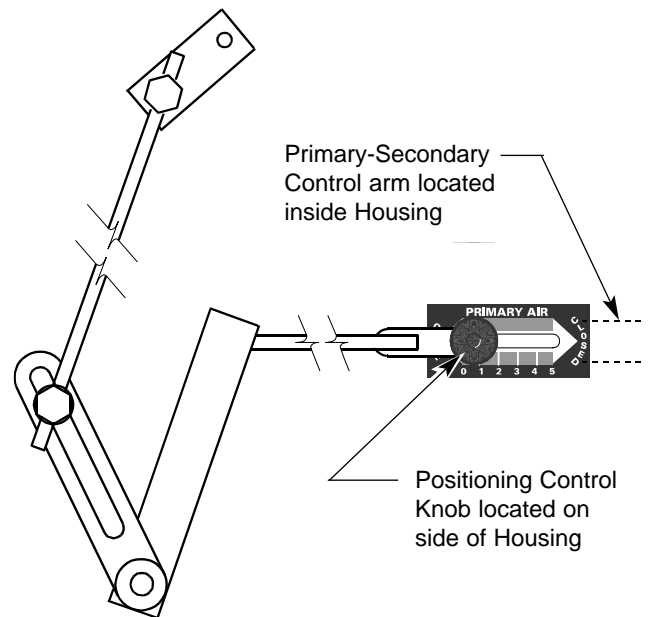

## Item 2A

## ADJUSTMENT OF AIR INLET LOUVER

### APPLICABLE TO THESE FUEL SYSTEMS

**B**  
GAS

**F1**  
OIL

**B-F1**  
GAS-OIL

### DESCRIPTION

These systems use an air louver which is spring loaded OPEN against an adjustable stop bracket. The system function when firing gas or oil is ON-OFF, FIXED AIR and FUEL.

### ADJUSTMENT PROCEDURE

1. Loosen screw holding louver adjustment bracket and move to desired position then retighten.
2. For initial start-up, set the louver so it is 1/2" open.

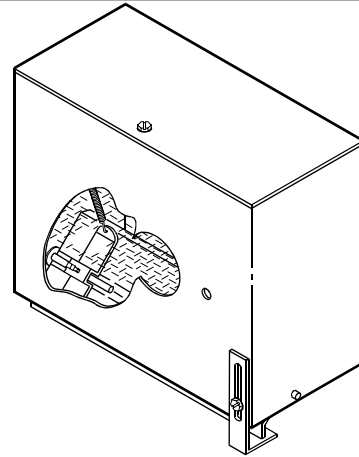

## Item 2B

### APPLICABLE TO THESE FUEL SYSTEMS

**F4B**  
GAS

**B-F4B**  
GAS-OIL

### DESCRIPTION

These systems use an air louver which is spring loaded OPEN against an adjustable stop bracket. When firing on oil, an oil cylinder and actuator arm arrangement move the louver to the CLOSED position for low-fire start. The system function when firing on gas is ON-OFF, FIXED AIR and FUEL. When firing on oil, ON-OFF, LOW FIRE START.

### ADJUSTMENT PROCEDURE

1. Loosen screw holding louver adjustment bracket and move to desired position then retighten.
2. For initial start-up:
  - a. Set the louver so it is 1-1/4" open.
  - b. Set the low-fire adjustment arm so there is 3/8" clearance between acorn nut on end of oil cylinder plunger and arm.

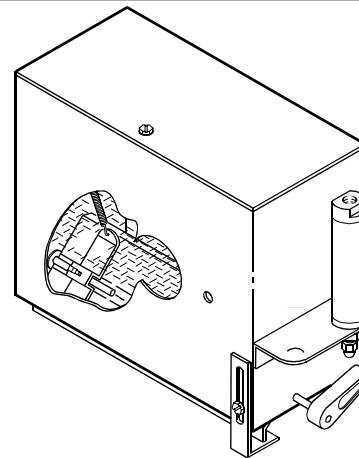

## Item 2C

### APPLICABLE TO THESE FUEL SYSTEMS

**H**  
GAS

**F4S**  
OIL

**H-F4S**  
GAS-OIL

### DESCRIPTION

These systems use an air louver which is spring loaded CLOSED against an adjustable stop bracket. When firing on oil, an oil cylinder and actuator arm arrangement moves the louver to the OPEN position for high fire. When firing on gas, a linkage arrangement to a motorized gas valve moves the louver OPEN. The system function is ON-OFF or HIGH-LOW, LOW FIRE START for both gas and oil.

### ADJUSTMENT PROCEDURE

1. Loosen screw holding louver adjustment bracket and move desired position then retighten.
2. For initial start-up:
  - a. Set the louver so it is 1/4" open.
  - b. Set the louver actuator arm (under the oil cylinder) so there is 3/8" clearance between acorn nut on end of oil cylinder plunger and arm.
  - c. Adjust linkage arrangement to motorized gas valve so louver will open approximately 1-1/4" when gas valve opens.

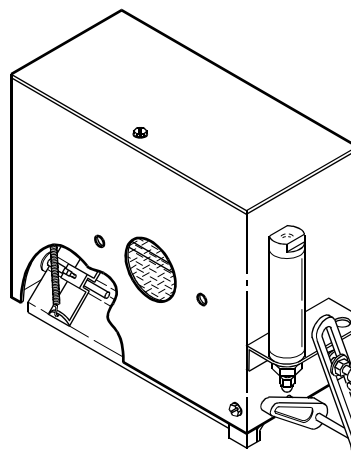

### NOTE

Motorized gas valves and the linkage arrangement used will vary. Use good mechanical judgement to insure the linkage adjustments will open the louver as the gas valve opens.

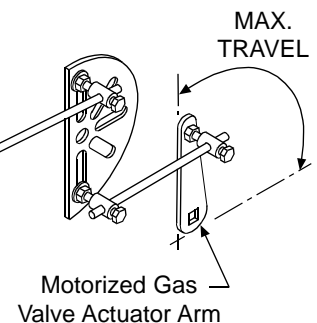

## ADJUSTMENT OF AIR INLET REGISTER

**Item 3A**

### APPLICABLE TO THESE FUEL SYSTEMS

<b>E2</b>	<b>F6R.2</b>	<b>F7.2</b>	<b>F7T.2</b>	<b>E2-F6R.2</b>	<b>E2-F7.2</b>	<b>E2-F7T.2</b>
<b>GAS</b>	<b>OIL</b>	<b>OIL</b>	<b>OIL</b>	<b>GAS-OIL</b>	<b>GAS-OIL</b>	<b>GAS-OIL</b>

### DESCRIPTION

These systems use an air inlet register which is opened and closed by an actuator, commonly termed a modulating motor. The system function is ON-OFF, HIGH-LOW or MODULATING, LOW FIRE START for both gas and oil.

### ADJUSTMENT PROCEDURE

1. Position ball-joint connectors to obtain desired opening for low fire and high fire. [See diagram below]
2. For initial start-up, set register openings at 1/4" for low fire.

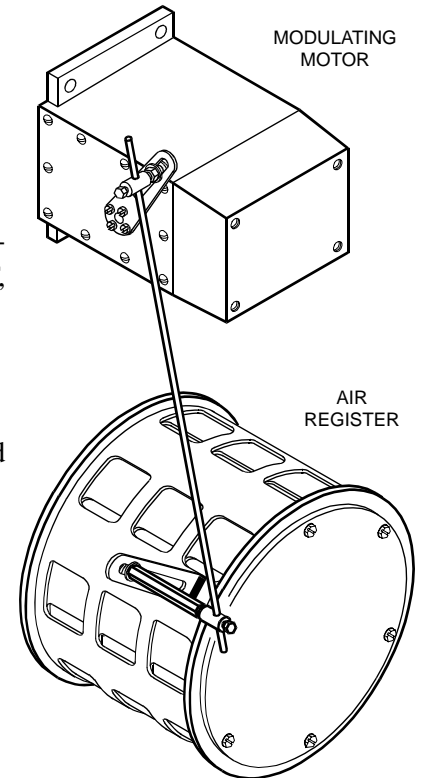
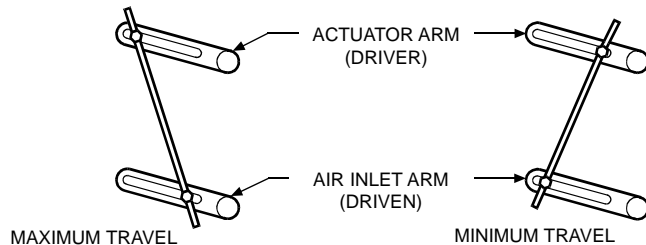

## ADJUSTMENT OF RECTANGULAR LOUVER BOX

**Item 3B**

### APPLICABLE TO THESE FUEL SYSTEMS

<b>E2</b>	<b>F6R.2</b>	<b>F7.2</b>	<b>F7T.2</b>	<b>E2-F6R.2</b>	<b>E2-F7.2</b>	<b>E2-F7T.2</b>
<b>GAS</b>	<b>OIL</b>	<b>OIL</b>	<b>OIL</b>	<b>GAS-OIL</b>	<b>GAS-OIL</b>	<b>GAS-OIL</b>

### DESCRIPTION

These systems use an air inlet register which is opened and closed by an actuator, commonly termed a modulating motor. The system function is ON-OFF, HIGH-LOW or MODULATING, LOW FIRE START for both gas and oil.

### ADJUSTMENT PROCEDURE

1. Position ball-joint connectors to obtain desired opening for low fire and high fire. [See diagram below]
2. For initial start-up, set register openings at 1/4" for low fire.

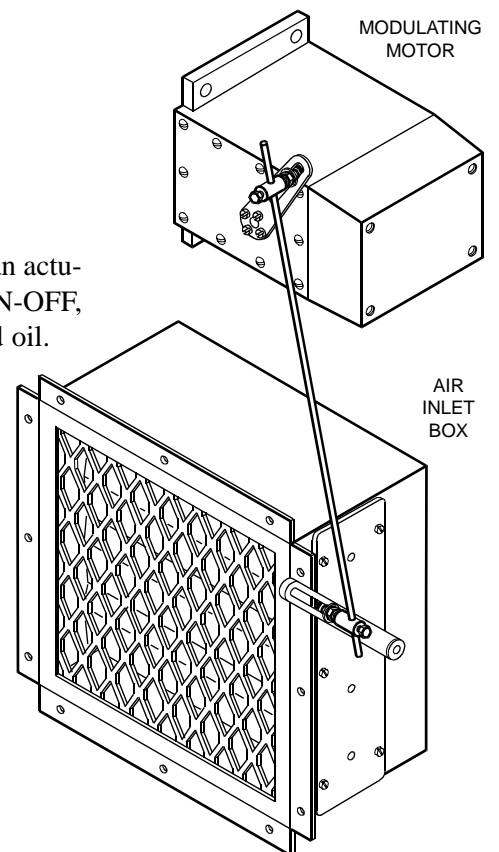
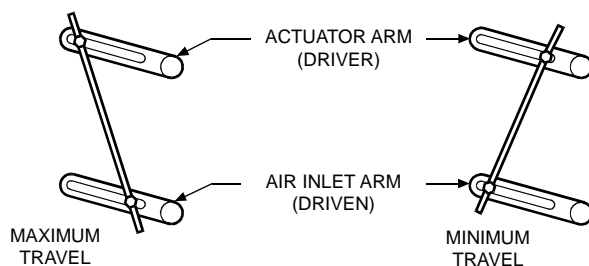

[OIL OR COMBINATION GAS-OIL BURNERS ONLY]

**NOTE**

On straight gas burners, the overall drawer assembly requires no adjustment. The air diffuser is positioned midway in the inner cylinder of the burner head and under normal firing conditions, requires no adjustment.

Direct spark oil ignition electrodes and photocell are also added to the assembly when the burner is ignited by direct spark and uses a rectifying photocell type flame detector.

**DESCRIPTION**

The basic assembly is made up of support piping, an air diffuser, and mounting provisions. For oil burners, a nozzle adapter and oil nozzle are added to make up the oil drawer assembly.

**ADJUSTMENT PROCEDURE**

Adjustment requirements cannot be finally established until after the burner is fired. Generally, the oil drawer assembly should be positioned as far to the rear [away from boiler] as possible without impinging the oil spray on the inner surfaces of the burner firing tube or choke ring.

**[Short Sight Flame Detector Tube with Gas Pilot]**

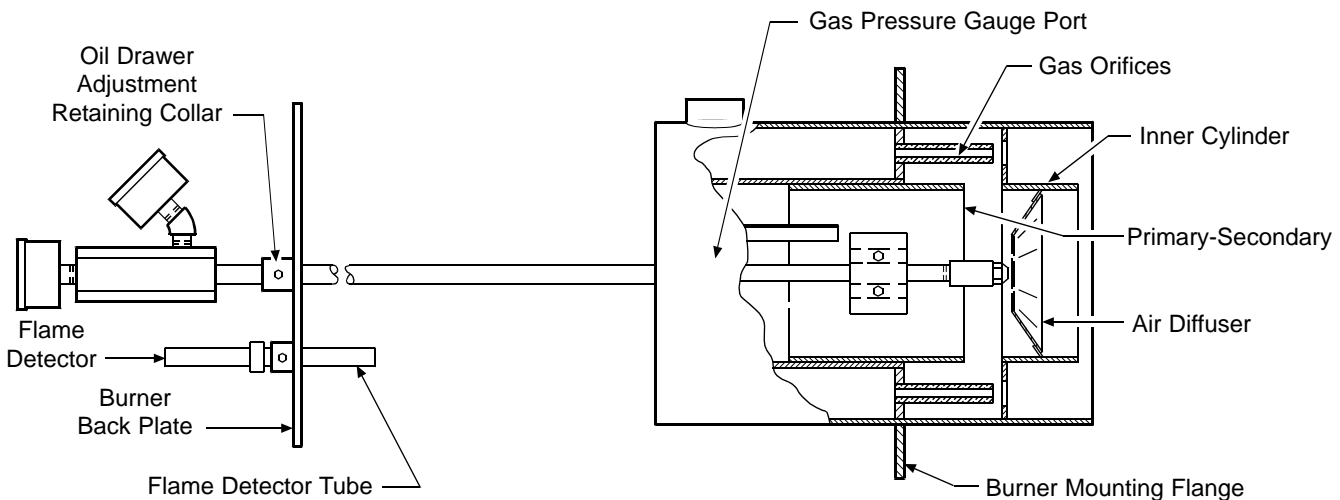

**[Long Sight Flame Detector Tube with Spark Ignition]**

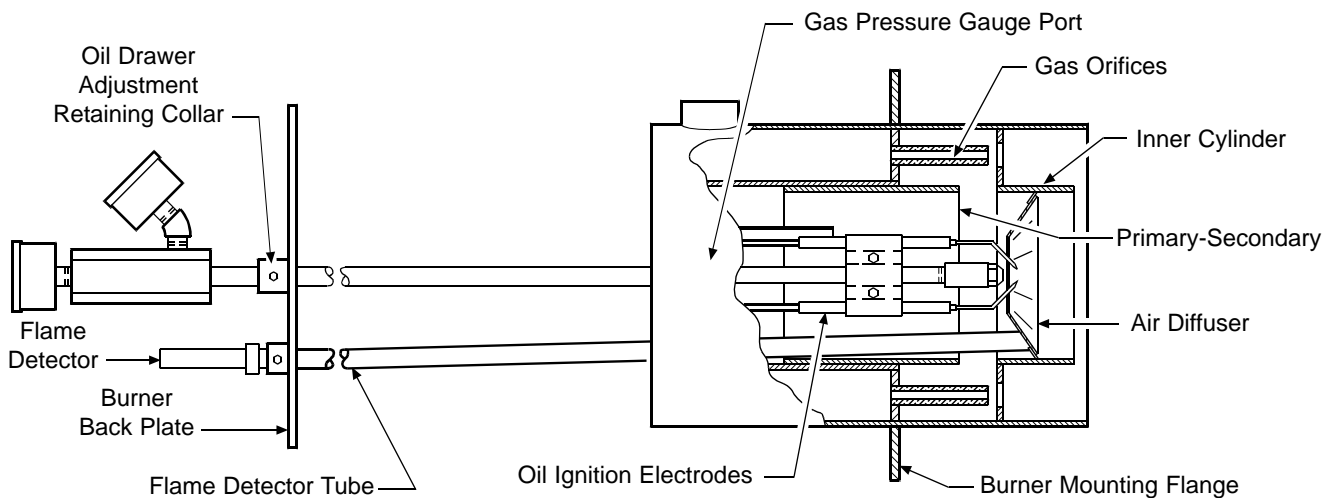

**DESCRIPTION**

The gas pilot igniter is basically composed of [1] An ignition electrode with insulator which generates an arc between it and the adjacent ground, and [2] A fuel tube through which the gas is directed to the point of the electrical arc.

A charge from a high voltage transformer is routed to the ignition electrode causing an intense arc to ground. The electrode is then immersed in a concentration of gas as the pilot solenoid valve opens allowing flow to the pilot. The arc ignites the gas, the electrical discharge from the transformer terminates and the pilot stands ready to ignite the main burner flame.

There are three versions of the gas pilot that may be used, all of which are direct spark ignited.

1. Type 214B6B with integral flame rod for rectifying flame detection systems.
2. Type 214D with integral scanner tube for lead sulfide or ultraviolet flame detection systems.
3. Type 216C with integral air supply. Note the 216C igniter does not contain facilities for the flame detector since this system is separate and apart from the igniter.

**ADJUSTMENT PROCEDURE (216B6B or 214D-B)**

**NOTE**

The gas pilot igniter assembly is a vital part of the burner and must be kept clean and properly adjusted at all times.

**WARNING**

Turn off power at the master switch and remove flame safeguard from the subbase.  
Turn pilot gas cock OFF.

1. Disconnect cables, lines or tubes from the igniter assembly and remove from burner housing.
2. Inspect components for cleanliness and proper adjustment settings as shown in the following illustrations.
3. Reinstall igniter assembly and flame safeguard after cleaning, adjustment or inspection.
4. Turn pilot gas cock back ON.

[TYPICAL]

**Type 214B6B**

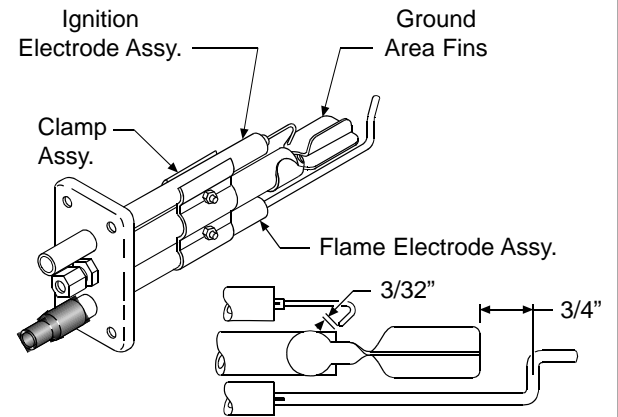

[TYPICAL]

**Type 214D-B**

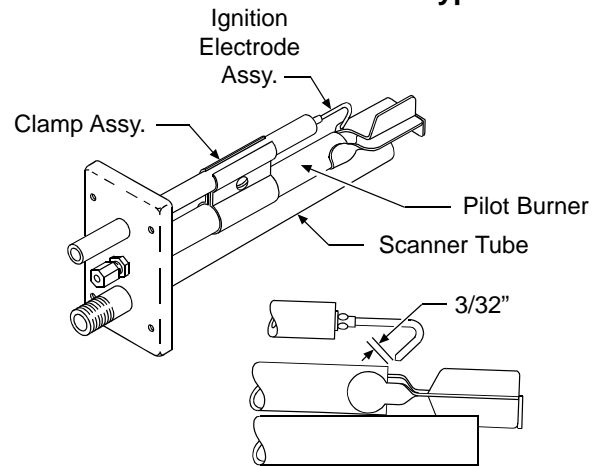

[TYPICAL]

**Type 216C**

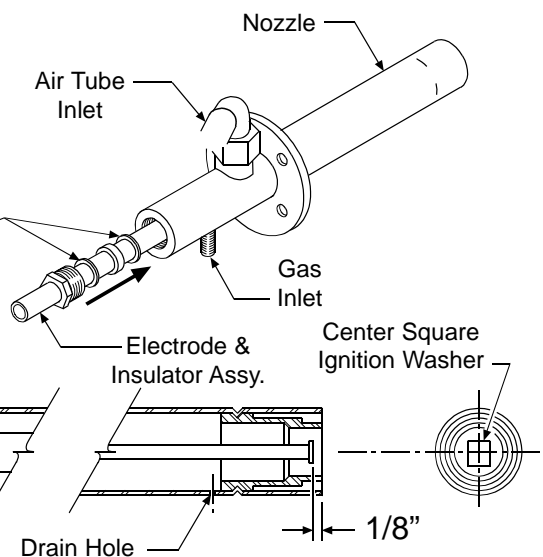

**NOTE**

Always install copper gasket with flat side to insulator.



**ADJUSTMENT PROCEDURE (216C)**

**NOTE**

The gas pilot igniter assembly is a vital part of the burner and must be kept clean and properly adjusted at all times.

**WARNING**

Turn off all electrical disconnects to the burner and any other equipment or systems electrically interlocked with the burner. Turn off the manual pilot gas valve

1. Disconnect cables, lines or tubes from the igniter assembly and remove from burner housing.
2. Inspect square ignition washer for cleanliness and proper adjustment as shown.
3. Remove ignition electrode assembly and check insulator for cleanliness and/or cracks.
4. Burnish end of electrode tip and insert of pilot tube assembly with a battery terminal cleaner or similar device.

5. Reinstall ignition electrode assembly and check that square ignition washer is approximately centered in pilot assembly. If not, loosen electrode locking nut and rotate assembly and tighten nut.
6. Reinstall pilot assembly in burner.

PILOT GAS ORIFICE CHART		
GAS	ORIFICE PART NO.	DIA.
NAT.	-----	.2130
LP.	230012-0154	.1540
NAT.	230012-0125	.1250
LP.	230012-0094	.0935
NAT.	230012-0106	.1065
LP.	230012-0070	.0700
NAT.	230012-0078	.0781
NAT.	230012-0073	.0730

**NOTE**

When viewing pilot flame, gas should be burning on full face of pilot insert.

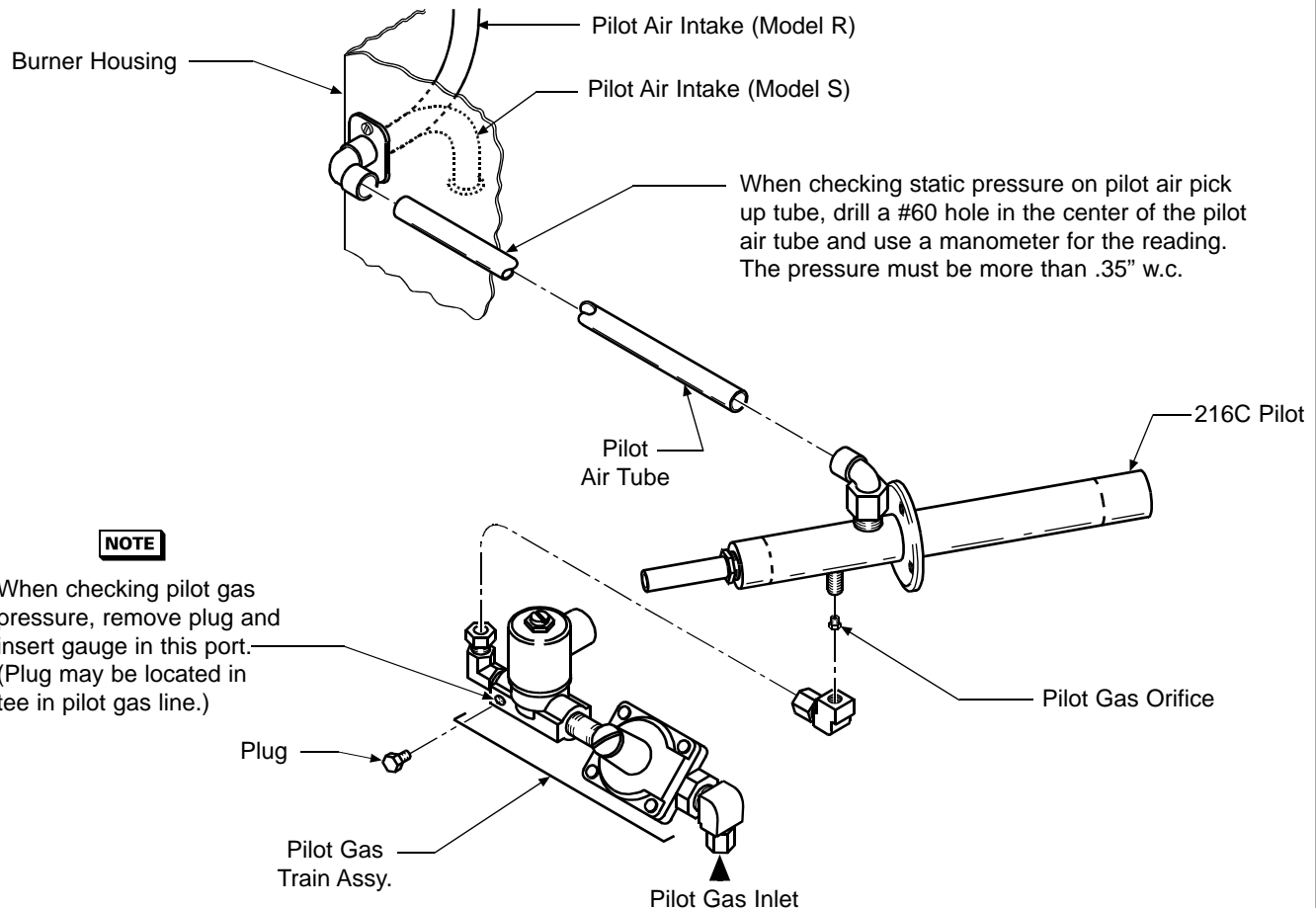

**PILOT TROUBLE SHOOTING**

**Item 5B**

<b>TROUBLE</b>	<b>PROBABLE CAUSE</b>	<b>ACTION</b>
Motor runs but ignition spark does not occur.	Ignition cable or electrode loose or grounded.	Check to insure that ignition cable is securely plugged into electrode. Check cable and clean if necessary.
		Remove and check electrode insulator for cracks.
	Pilot ignition transformer defective.	Check for 120 volts on ignition transformer panel terminal. Replace transformer if required.
	Defective flame safeguard.	Check voltage on ignition terminal. Replace flame safeguard if required.
	Carbon hair on ignition electrode to ground.	Carefully remove pilot assembly and check for carbon hair. Remove, clean pilot assembly and ignition electrode, re-install and re-adjust pilot gas pressure for a leaner burner pilot.
Motor runs, ignition occurs, but gas does not ignite.	No gas being supplied to pilot.	Check the manual pilot gas valve to insure that it is open.
		Make sure gas line has been purged of air.
		Pilot orifice plugged, clean.
		Gas pilot regulator locked up. Check inlet gas supply pressure. Replace gas pilot regulator.
	Pilot gas valve does not open.	Check for 120 volts to coil. Check valve action by sound and feel. Replace coil or valve body as needed.
Motor runs, gas pilot establishes, pilot flame does not prove.	Improper gas flow.	Increase or decrease gas pressure to pilot.
	Flame sensor dirty.	Clean or replace sensor.
	Flame sensor cannot see pilot.	Look down thru sight tube. If unable to get clear view of pilot, correct problem.
	Improper ground circuit.	Check for voltage on neutral wire to panel ground. Voltage must not be more than .5 volts.
	Pilot air supply incorrect.	Check static pressure on pilot air pick up tube. Must be more than .35" w.c. pressure. Open low fire air setting more.

**DESCRIPTION:**

The air flow switch is used to prove the flow of combustion air from the blower assembly. It causes the fuel valve to close or fail to open upon loss of or inadequate combustion air.

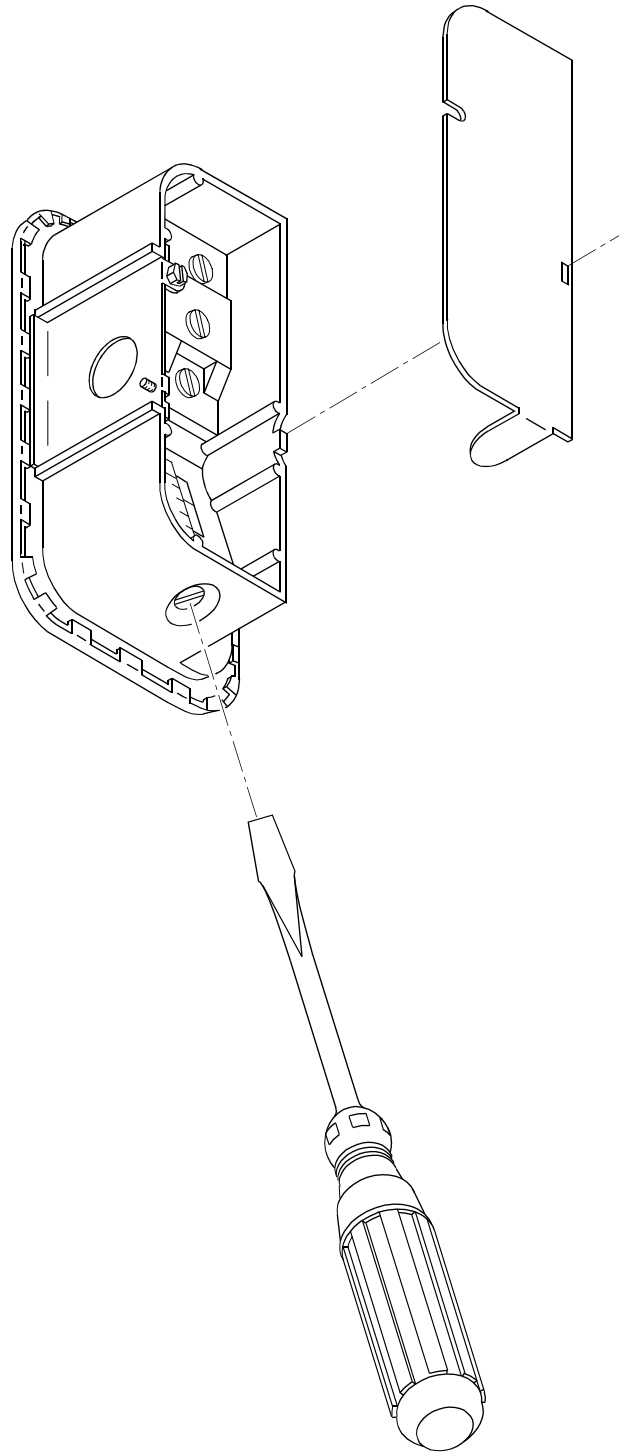
**ADJUSTMENT PROCEDURE:**

1. Switches should be set to break (open) when combustion air is substantially reduced.
2. If applicable, remove cover to adjusting screw.
3. Turn adjusting screw clockwise to increase set point or counterclockwise to decrease set point.

**DESCRIPTION**

Gas burners have two gas pressure regulators, one to regulate the pressure to the main flame and the other to regulate the gas pilot igniter. Larger oil burners also use gas pilot ignition, therefore, the gas pressure regulator is common to many Model R and S burners.

Simply stated, gas flow is controlled by a spring of known load range which works against the supply [from the meter] gas pressure, therefore each regulator must be fitted with the right spring for it to function properly. Additionally, the tension on the regulator spring must be adjusted to obtain the exact gas pressure required at the inlet to the controls.

**ADJUSTMENT PROCEDURE**

**NOTE**

See gas pressure regulator manufacturer's instructions for detailed procedures.

1. Remove cap or bonnet from regulator to gain access to adjustment screw or button.
2. Turn clockwise to increase and counter-clockwise to decrease outlet pressure.

**GAS PRESSURE REGULATOR**

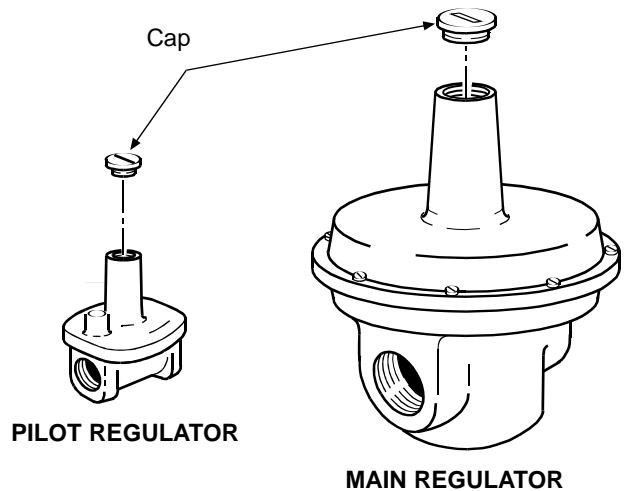

PILOT REGULATOR

MAIN REGULATOR

3. For initial start-up:

**NOTE**

Pressure at which gas will be delivered the the burner cannot be determined without gas flowing thru the regulator. Be prepared to adjust the regulator as the burner is test fired.

4. Reinstall cap or bonnet after adjustment.

ADJUSTMENT OF BUTTERFLY GAS VALVE

**DESCRIPTION**

The butterfly gas valve is a fuel throttling device which proportions the gas in proper ratio to the combustion air. the valve is opened or closed by an actuator as the combustion control programs the burner firing rate to meet the boiler load.

A centrally located disc turns within a cylindrical body which regulates the gas flow to the main burner flame. The butterfly valves use are the non-tight shutoff type.

Through a linkage system, an actuator drives the valve open or closed in response to electrical signals from the combustion control. Since the amount of air available for combustion is controlled by the same actuator, a proper fuel-air ratio is maintained at all times.

**ADJUSTMENT PROCEDURE**

1. Use box end or socket wrench to loosen or tighten ball joint connectors.

**BUTTERFLY GAS VALVE**

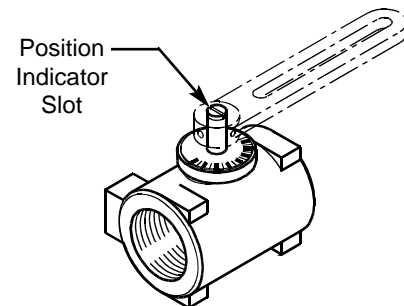

2. To adjust low fire [minimum] fuel setting, loosen ball joint connector holding drive rod and manually position butterfly disc to desired opening, then retighten connector.

**NOTE**

Slot in end of butterfly shaft indicates position of internal disc.

3. For initial start-up: Position actuator arm so internal disc is approximately 15° open.

## Item 9

## ADJUSTMENT OF GAS PRESSURE SWITCH

### DESCRIPTION

Gas pressure switches are pressure-actuated electrical switching devices designed for safety shutoff when gas pressures are either too low or too high.

The pressure switch senses any change in gas pressure and, if properly adjusted, will transmit an electrical signal to the automatic shutoff valve and/or other interlocking devices when an unsafe condition exists. The burner will then recycle or completely shut down depending upon the flame safeguard used. Gas pressure switches are designed to operate over a specified pressure range; therefore, each switch must be selected to be compatible with the burner operating gas pressure and also to obtain the desired electrical features.

### ADJUSTMENT PROCEDURE

#### NOTE

See gas pressure switch manufacturers instructions for detailed procedures. Units with mercury switching device must be properly leveled.

### GAS PRESSURE SWITCH

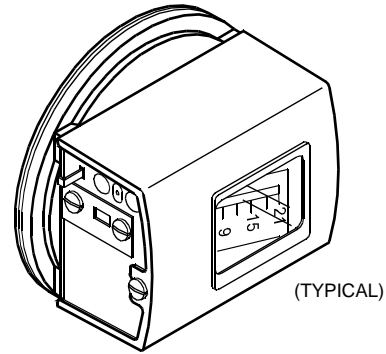

1. For initial start-up:
  - a. **Low Gas Pressure Switch** - Adjust to a lower pressure than that to be experienced for normal operation to allow the burner to be set up.
  - b. **High Gas Pressure Switch** - Adjust to a higher pressure than that to be experienced for normal operation to allow the burner to be set up.

#### NOTE

Final adjustment must be done after the burner has been test fired. See burner start-up procedures.

## Item 10

## ADJUSTMENT OF OIL SUPPLY PRESSURE REGULATOR

### DESCRIPTION

Oil burners require a close regulation of the pressure at which oil is delivered to the nozzle. Small GPH burners normally use an oil pump which has a pressure regulator built-in, while larger capacity burners employ a separate pressure regulating valve.

Burner oil pumps are generally identified by the rate at which they can deliver [GPH], the pressure of the delivery [PSIG], and the speed of rotation [RPM]. The pump is usually capable of delivering more fuel than is required to meet firing requirements; therefore, the amount of oil delivered to the nozzle must be controlled. This control is accomplished through use of an adjustable pressure regulating valve which reduces flow to the nozzle by causing more oil to be returned to the tank. Like most regulators, flow is controlled by an adjustable spring and each regulator has a pressure range over which it will reliably operate.

### ADJUSTMENT PROCEDURE

#### NOTE

See oil pressure regulator or oil pump manufacturer's instructions for detailed procedures.

### OIL PRESSURE REGULATOR

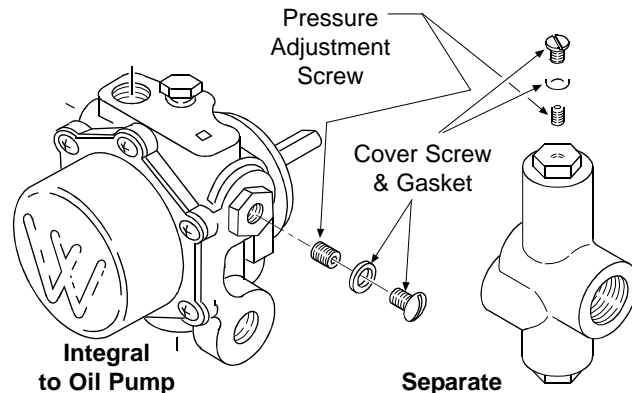

1. Using screw driver, remove cover screw and gasket thereunder to gain access to the adjustment mechanism.
2. Use 1/8" Allen wrench to turn pressure adjusting screw clockwise to increase pressure and counter-clockwise to decrease.
3. For initial start-up:

#### NOTE

Pressure at which oil will be delivered to the nozzle cannot be determined until the burner is test fired. Be prepared to adjust the regulator as the burner is cycled through its firing sequence.

**DESCRIPTION**

Oil burners which have low fire start fuel control systems must deliver oil to the nozzle reduced pressure for low fire. This is normally accomplished by diverting a portion of the oil pump delivery through a bypass return line to the tank.

The amount of oil delivered to the nozzle versus that returned to the tank is controlled by a device which limits or meters flow, thus an oil bypass regulating valve or an oil metering valve is used for this purpose.

**ADJUSTMENT PROCEDURE**

1. Using screw driver, remove cover screw and gasket to gain access to the adjustment mechanism.
2. Use 1/8" Allen wrench to turn pressure adjusting screw clockwise to increase pressure and counter-clockwise to decrease.

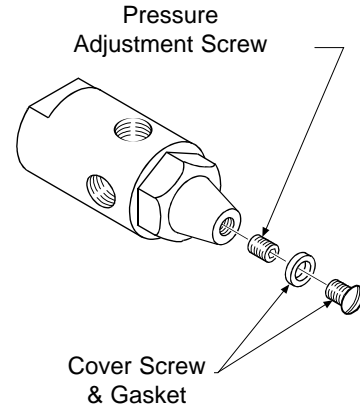
**BYPASS PRESSURE REGULATING VALVE**

3. For initial start-up:

**NOTE**

Pressure at which oil will be delivered to the nozzle cannot be determined until the burner is test fired. Be prepared to adjust the regulator as the burner is cycled through its firing sequence.

**ADJUSTMENT OF OIL METERING VALVE****DESCRIPTION**

Most oil metering devices work on the principle of limiting flow by constricting the area through which the oil must pass. In order to vary the orifice area, mechanical movement must take place, thus the oil metering valve requires an actuator to do its job. By interconnecting a common actuator to the combustion air control and the oil metering valve, this allows the fuel [oil] to be proportioned in precise ratio to the amount of air available for combustion. This feature is essential on modulating type fuel control systems.

**ADJUSTMENT PROCEDURE****NOTE**

Valves vary by the amount of rotation required to cover the full range of regulation. Most valves will have a range from 0° to 90° or 0° to 120°. The maximum travel that can be realized from a 90° actuator and mechanical linkage arrangement is about 120°. The amount of travel to be used is dependent upon the required turndown ratio [flow rates] between high-fire and low-fire and the flow characteristics of the particular valve.

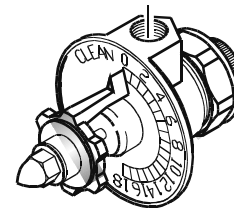
**OIL METERING VALVE**

- For initial start-up:

**NOTE**

Adjustment requirements cannot be finally established until after the burner is fired. Generally, the valve should work from a mostly open position when located in the bypass return line or from a mostly closed position when located in the supply line. This allows limited flow to the nozzle for low fire start.

**DESCRIPTION**

Low oil pressure switches are often times used to insure the oil pressure at the nozzle is adequate for proper atomization of the oil.

A pressure sensing device within the switch controls an electrical circuit normally interlocked with the flame safeguard causing the burner to recycle or shut down when the pressure sensed falls below the setting.

**ADJUSTMENT PROCEDURE****NOTE**

See pressure switch manufacturer's instructions for detailed procedure.

1. From burner material list determine "Oil Pressure at Nozzle" [PSIG] requirement.
2. For initial start-up: Adjust to a pressure well below the "Oil Pressure at Nozzle" [PSIG] shown to allow the burner to be set up.

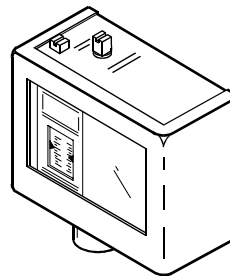
**LOW OIL PRESSURE SWITCH**

[Typical]

**NOTE**

Final adjustment must be done after the burner has been test fired. See burner start-up procedures.

A considerable amount of oil burner service is associated with poor ignition or failure to obtain ignition.

This condition is oftentimes caused by an out-of-tolerance adjustment of the oil ignition electrodes in relation to the nozzle and/or the nozzle to the air diffuser. The spark gap must also be properly set.

The following information is furnished as a guide for obtaining those settings that will insure reliable performance of the oil ignition system and also prevent unnecessary build-up of soot and carbon on the electrodes and air diffuser.

**GENERAL**

There are several factors which affect the adjustments and general maintenance of the oil ignition system. These are:

1. The type of nozzle used.
2. The number of nozzles used.
3. The nozzle spray angle.
4. The diameter of the center (nozzle) hole in the air diffuser.
5. The velocity of the air moving through the burner head.

**TYPE OF NOZZLE**

The simplex nozzle is used with oil systems which have a supply pipe **ONLY** while the variflow (or bypassing) oil nozzle is used with a **TWO-PIPE** arrangement, one for supply and the other for return.

**NOTE**

The table at right shows the type of nozzle(s) used in the various John Zink Company oil systems which may have direct spark ignition.

OIL SYSTEM	TYPE NOZZLE	
	SIMPLEX	VARIFLOW
F1	x	
F4B	x	
F4H	x	
F6	x	
F6R	x	
F7		x
F7T		x

**NUMBER OF NOZZLES**

The number of nozzles used varies by application except for the F7T oil system which two or three variflow nozzles. The use of multiple nozzles in turn normally requires the use of an air diffuser with a larger center hole diameter to preclude impingement of the oil on the diffuser cone.

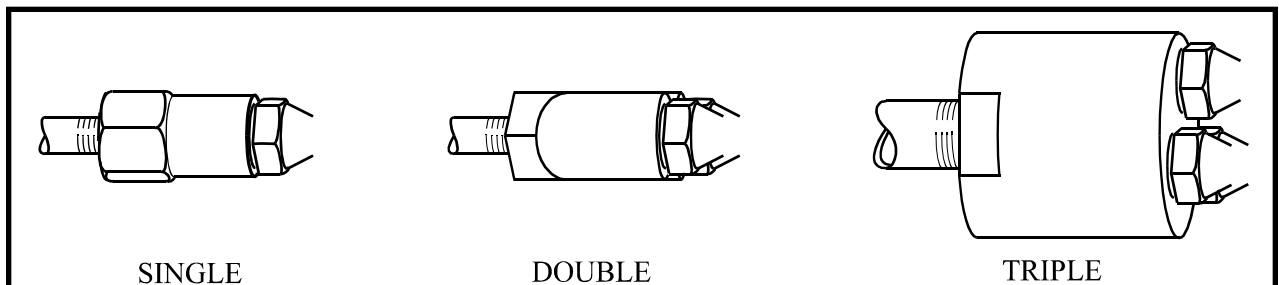

**NOZZLE ARRANGEMENTS**



### NOZZLE SPRAY ANGLES

There are a number of commercially available nozzles with different spray angles. Like the number of nozzles used, the spray angle also varies by application. Replacement nozzles should always have the same spray angle as those being replaced.

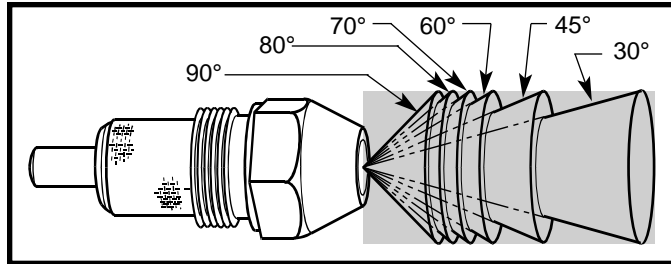

#### NOTE

John Zink Company pressure atomizing burners use mostly Delavan brand oil nozzles.

### AIR DIFFUSER CENTER HOLE DIAMETER

Center hole diameters vary by the number of nozzles used, the nozzle spray angle and the velocity of the combustion air. This is determined at the factory by application but from time to time the diffuser and nozzle spray angle may be changed in the field to obtain best results.

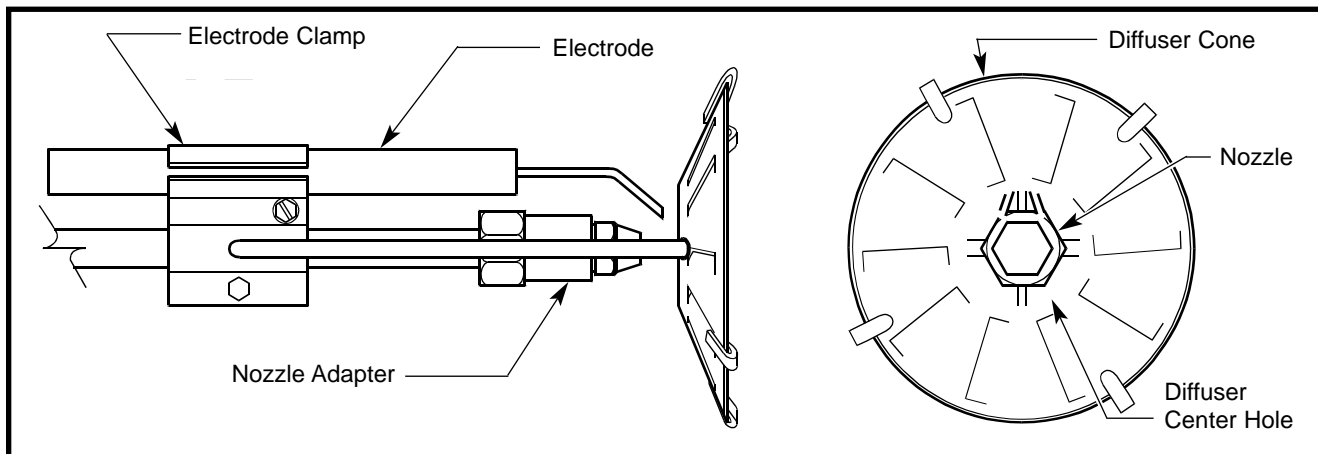

TYPICAL AIR DIFFUSER, NOZZLE AND ELECTRODE ARRANGEMENT

### ADJUSTMENT PROCEDURE

#### CAUTION

The final adjustments must not allow the fuel oil to impinge on the air diffuser or oil ignition electrodes.

There are two adjustments which control the function of the direct spark oil ignition system:

1. The location of the nozzle in relation to the air diffuser.
2. The location of the ignition electrodes in relation to the nozzle.

The ultimate objective of these adjustments is to:

1. Position the nozzle so that the fuel oil spray clears the inside hole diameter of the air diffuser by at least one-eighth ( $1/8$ " ) inch.
2. Position the tips of the oil ignition electrodes so they are within one-sixteenth ( $1/16$ " ) inch of the fuel oil spray.

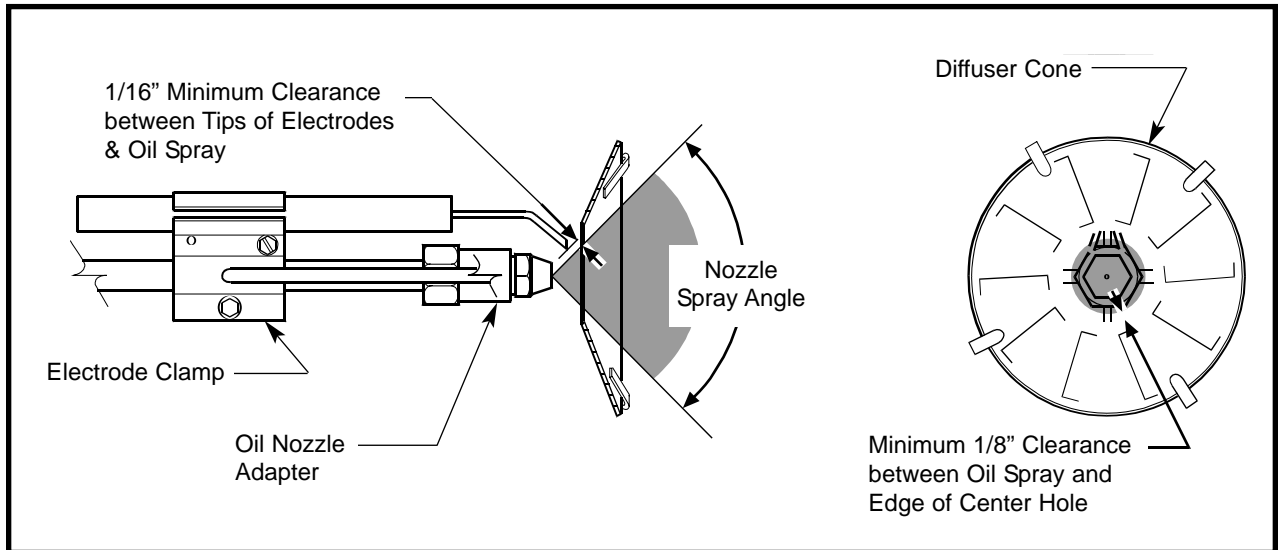

### OPTIMUM ADJUSTMENTS

The following dimensional data applies to the adjustment of the JACOB'S LADDER type ignition electrodes used on John Zink Company burners since November, 1975.

- A. Determine these Things:
  1. Center hole size in your air diffuser.
  2. The type of nozzle used, simplex or variflow.
  3. The nozzle spray angle.
  4. The number of nozzles used, one, two or three.
- B. Refer to the following dimensional data table and typical oil nozzle arrangements illustration for adjustments.

#### NOTE

The spark gap between electrodes is  $1/8$ " for 12,000 volt transformers and  $1/16$ " for 10,000 volt transformers.

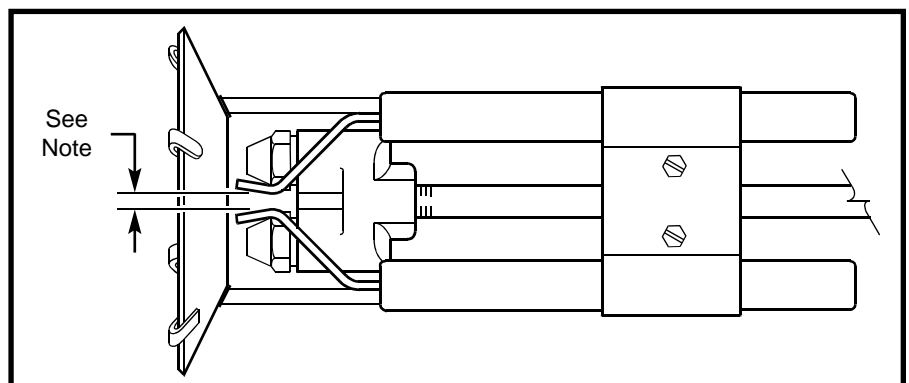

### SPARK GAP

## DIMENSIONAL DATA

DIFFUSER CENTER HOLE SIZE	NOZZLE DATA			ADJUSTMENT SETTINGS (SEE ILLUSTRATIONS)		
	TYPE	SPRAY ANGLE	QUANTITY	A	B	C
1	Simplex	30°, 45° 60°	1	1/4	1/8	3/8
1-3/8	Simplex	90°	1	1/4	3/16	7/16
		60°	1	3/8	1/4	7/16
1-1/2	Simplex	90°	1	3/8	3/16	7/16
		60°	1	5/8	1/4	
1-3/4	Simplex	90°	1	7/16	3/16	7/16
		60°	1	5/8	1/4	
		90°	2	1/16	Flush	
		60°	2	5/16	1/4	
1-13/16	Simplex	90°	1	7/16	3/16	7/16
		60°	1	3/4	1/4	
		90°	2	1/4	3/16	
		60°	2	7/16	3/16	
2-1/16	Simplex	90°	2	1/4	1/4	7/16
		60°	2	9/16	5/16	
	Variflow	90°	1	9/16	5/16	1/2
		60°	1	7/8	1/2	
		45°	1	1-3/8	3/4	
		90°	3	1/4	5/16	
		60°	3	3/8	7/16	
45°	3	1/2	1/2			
30°	3	1/2	1/2			
2-1/4	Simplex	90°	2	3/8	1/4	7/16
		60°	2	9/16	5/16	
	Simplex	90°	3	1/4	5/16	1/2
		60°	3	3/8	7/16	
	Variflow	90°	3	1/4	5/16	5/8
		60°	3	7/16	7/17	

**1** All dimensions shown are in inches.



Regardless of dimensions shown, there should be NO IMPINGEMENT of the oil on the ignition electrodes or air diffuser.

Manufacturing tolerances in both the nozzle and the oil drawer assembly may cause variations in the above dimensions.

It is recommended that after all adjustments have been made and the burner has been test fired that the oil drawer assembly be removed and examined for wetting or excessive carbon build-up. Evidence of these conditions requires re-adjustment.

**NOTE**

See Next Page for Illustrations

TYPICAL OIL NOZZLE ARRANGEMENTS

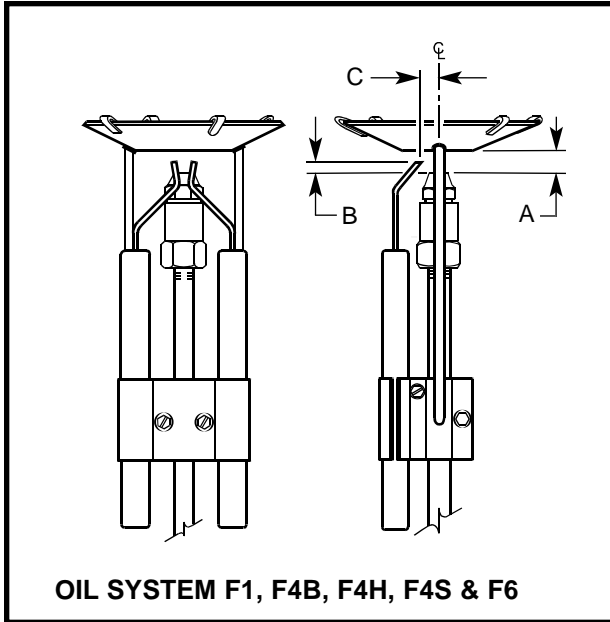

SINGLE SIMPLEX

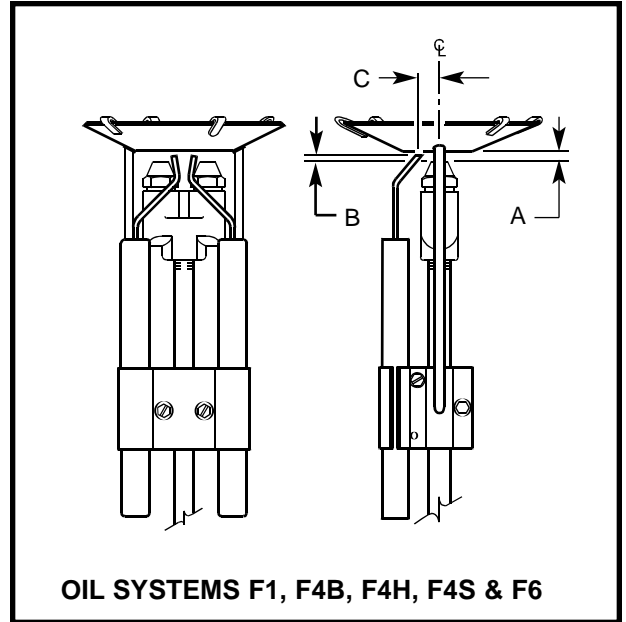

DUAL SIMPLEX

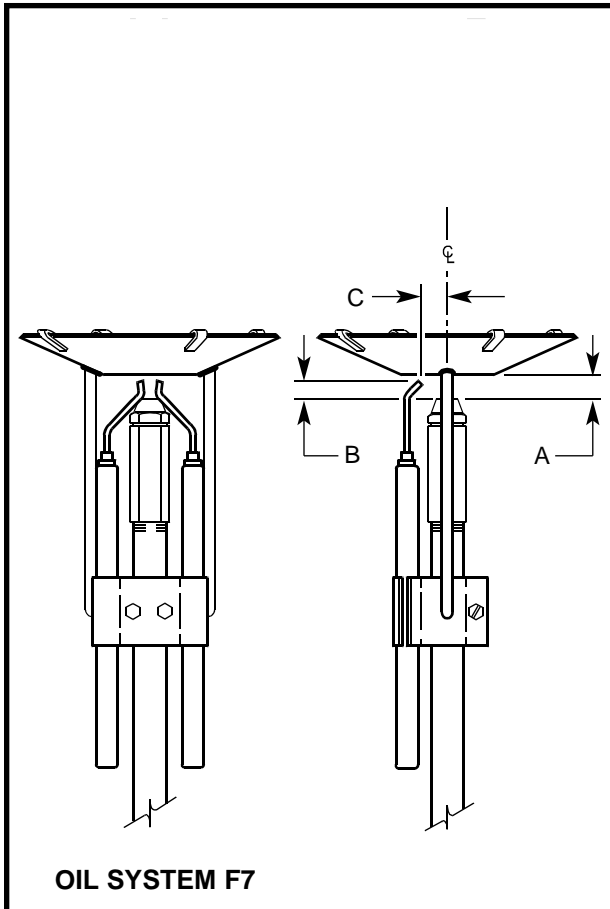

SINGLE VARIFLOW

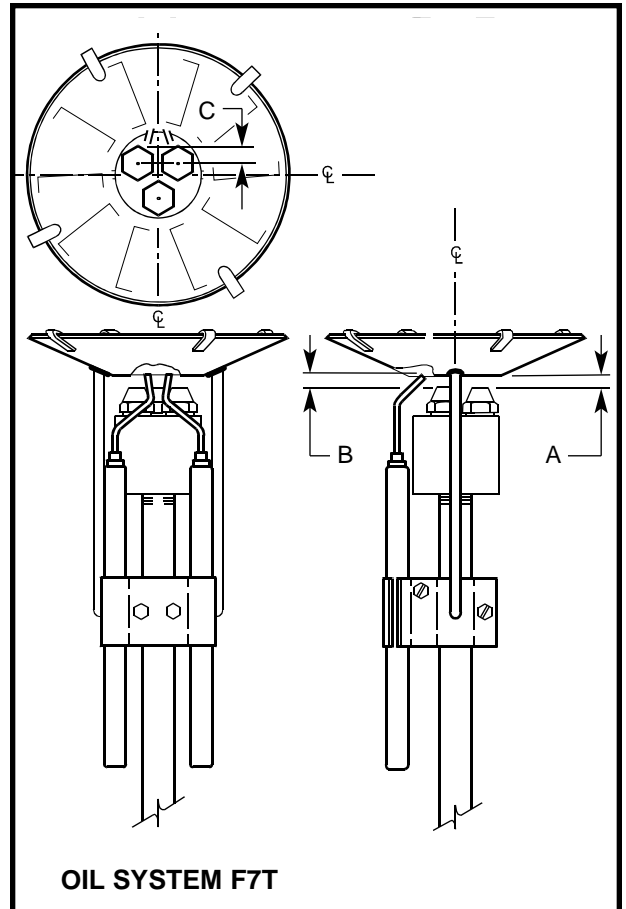

TRIPLE VARIFLOW

**DESCRIPTION**

Characterized linkage provides the mechanical means to fine tune the fuel input (flow) to the burner in order to achieve maximum fuel efficiency and reduce harmful stack emissions.

There are nine (9) adjustment screws which control the contour of a flexible metal track upon which a roller and plunger mechanism travel. This mechanism in turn controls the linkage to the fuel valve, providing the precise amount of travel to dispense the right amount of fuel to the burner as it modulates to meet load demand. The objective is to shape the flexible metal track into what amounts to a “combustion deficiency profile”.

**ADJUSTMENT PROCEDURE**

Factory checkout verifies there is freedom of movement in all linkages throughout the 90° travel of the modulating motor. For gas systems, the butterfly (throttle) valve is set at the slightly open position. For oil systems, the oil metering valve is set at a predetermined position, depending on the specific valve used. Both settings are normally adequate to facilitate start-up.

Adjustment of the characterized linkage should only be done after the burner has been successfully started-up and taken from low-fire to high-fire several times. Any necessary adjustments to the fuel control linkages during start-up should be done at a ball joint connector or linkage rod coupling. The boiler, or other appliance being fired, should be warm.

Generally, combustion readings should be taken at each of the nine (9) adjustment screws in the quadrant. AS A STARTING POINT, low and high fire flue gas composition should be in the tabulated range shown below:

There should be no more than 3/16” variation between adjacent screws.

**CHARACTERIZED LINKAGE (typical)**

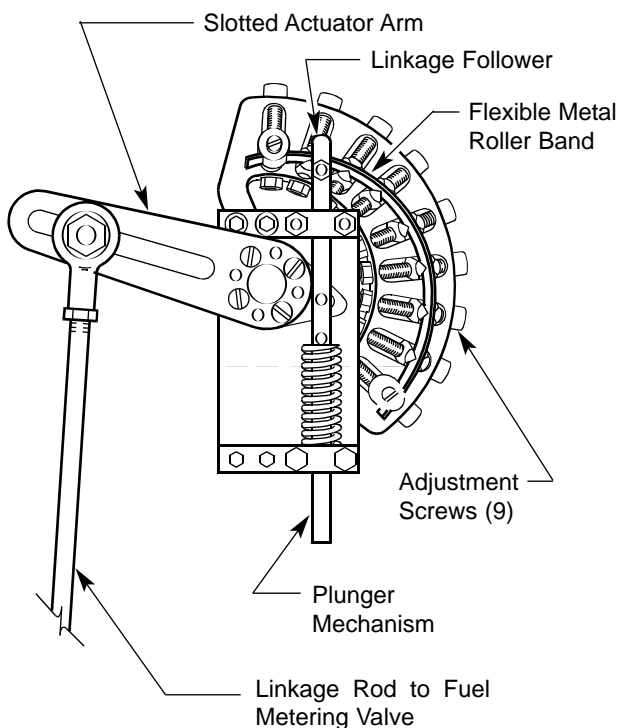

**CAUTION**

There should be no more than 3/16” variation between adjacent screws.

FUEL	LOW FIRE		HIGH FIRE	
	CO <sub>2</sub>	O <sub>2</sub>	CO <sub>2</sub>	O <sub>2</sub>
Natural Gas	7½ - 9	8½ - 5	9 - 10½	5 - 2½
#2 Oil	9 - 11	8½ - 5	11 - 12½	6 - 3½

The final fuel/air ratio curve must be determined on the basis of clean combustion at all firing rates. Sufficient combustion air must be available to keep the CO generated by a gas fire below 50 PPM at all rates. Smoke level on #2 oil should not exceed a #2 spot on the Bacharach scale.

# PART VIII

## BURNER START-UP

### CAUTION

This manual has been prepared as a guide in burner start-up operations. It is written for the start-up specialist who is thoroughly qualified both by training and experience.

- 1. GENERAL** - The following data is pertinent to the burner start-up and should be carefully studied before any attempt to operate the burner is made. This material is a part of the manual shipped with the burner.

- Burner Material List
- Burner Wiring Diagram and Operating Sequence
- Flame Safeguard Bulletin
- Gas System Bulletin [if applicable]
- Oil System Bulletin [if applicable]
- Miscellaneous Manufacturer's Data on Controls, Valves, Regulators, etc.

### NOTE

The above cited manual is ONE OF A KIND in that it contains material covering your SPECIFIC burner. To replace it, considerable time, special handling and significant costs are involved. Accordingly, it should be handled with care and kept in a location free of dust and moisture.

- 2. FLAME SAFEGUARD INSTALLATION** - Assure flame safeguard is properly installed in its subbase.

### NOTE

The Burner Flame Safeguard is often-times packaged and shipped in a separate carton; however, the control cabinet will contain the mounting subbase which is installed and prewired at the factory. See separate instructions on Flame Safeguard for mounting the unit in the subbase.

- 3. IDENTIFICATION OF CONTROLS** - Review the burner wiring diagram and operating sequence. Study these items and identify the various controls from the typical control panel assemblies shown in Part VI.

### NOTE

Do not proceed with start-up unless all applicable checklist  items in Parts I and II and preliminary adjustment requirements in Part VII have been satisfied.

If the burner is a combination gas-oil unit, it is recommended that the burner be fired on GAS first so the correct input rate in BTU's per hour may be determined by reading the gas meter.

### WARNING

Be certain combustion chamber, flues, and surrounding areas are free of GAS accumulations, OIL or OIL VAPOR and other combustibles such as paint thinners, cleaning solutions, etc. An explosimeter [Mine Safety Appliances Co. model No. 2A or equivalent] should be used to make this determination.

- 4. GAS BURNERS** - [See Paragraph 5 for oil burners]

- 4.1 REVIEW BURNER MATERIAL LIST IN THE INSTRUCTIONS MANUAL AND ANNOTATE THE FOLLOWING INFORMATION:**

- a. Firing rate [MBTU]
- b. Cubic feet of gas per hour [CHF]
- c. BTU per cubic foot [BTU/CF]
- d. Required gas pressure at control inlet [inches W.C.]
- e. Required gas pressure at orifices [inches W.C., taken at burner manifold]

The above information is pertinent to setting up the burner.

4.2 START-UP SETTINGS OF BURNER FIRING CONTROLS - Using the burner operating sequence, proceed up to the step which calls for opening the manual gas valve(s).

**WARNING**

During initial start-up, the operator must be on constant alert for emergency conditions such as fuel leaks, electrical malfunctions, etc. The location of all manual shutoff valves and switches should be clearly in mind so the burner can be quickly shut down if necessary. Should the burner fail to ignite, never manually manipulate the flame safeguard sequence which provides for purging of the combustion chamber.

4.3 Using the manufacturer's instructions bulletin on the FLAME SAFEGUARD, proceed with check out to insure proper function of the safeguard under burner operational conditions. Table 8-1 shows those checks that should be performed.

**NOTE**

While performing these checks, certain adjustments and readings must be made at the appropriate time. These include:

- a. Burner combustion air
- b. Gas pressure [at control inlet and orifice]
- c. Boiler limit controls
- d. Draft controls
- e. Other controls electrically interlocked with the burner control system
- f. Gas flow thru utility meter [CFH]
- g. CO<sub>2</sub> and CO
- h. Stack temperature

4.4 LOW AND HIGH GAS PRESSURE SWITCHES - If burner is equipped with low and high gas pressure switches, perform the following steps:

**LOW GAS PRESSURE SWITCH ADJUSTMENT**

- a. Close the main manual gas shutoff valve and install a manometer in the upstream test port of the safety gas shutoff valve.
- b. Reopen the main manual gas shutoff valve.
- c. Cycle the burner to high fire and take gas pressure reading on manometer. Using the main manual gas shutoff valve, throttle down the gas flow to a point where the manometer reading is approximately 10% below the previous reading, then adjust the low gas pressure switch downward until it breaks and shuts down the burner. Restore main manual gas shutoff valve to full open.
- d. To insure the switch is functionally sound and properly installed, recycle the burner to high fire and again use the main manual gas shutoff valve to throttle the gas flow. The low gas pressure switch should immediately break and shut down the burner at 10% reduced pressure.
- e. Turn main manual gas shutoff valve to off, then remove manometer and reinstall test plug in gas safety shutoff valve. Restore main manual gas shutoff valve to full open.

The Items Below Summarize the Flame Safeguard Checkout Tests Required for Each Type of Installation

Checkout Item	When Performed
1. Preliminary Inspection	For All Installations
2. Flame Signal Measurement	For All Installations
3. Initial Lightoff Check with Proven Pilot	If Pilot Must be Proven Before the Main Fuel Valve Can Open
4. Pilot Turndown Test	If Pilot Must be Proven Before the Main Fuel Valve Can Open
5. Hot Refractory Hold-In Test	For All Photocell (Rectifying or Infrared Lead Sulfide) Applications
6. Hot Refractory Over-ride Test	For All Infrared (Lead Sulfide Photocell) Detector Applications
7. Ignition Spark Response Test	For All Ultraviolet Detector Applications
8. Flame Signal with Hot Combustion Chamber	For All Installations
9. Safety Switch Lockout Tests	For All Installations

Table 8-1 Flame safeguard Checkout Summary

- f. Cycle the burner on-off several times to assure the switch will not cause nuisance shutdowns as the burner ignites.

**HIGH GAS PRESSURE SWITCH ADJUSTMENT**

- a. Cycle the burner to high fire. Slowly adjust the switch downward until the switch breaks and shuts down the burner, then reverse the adjustment so the setting is approximately 10% greater than the reading at which the switch broke.

**Example**

If the switch broke and shut down the burner at 4.0" w.c., then set the switch at 4.5" w.c.

- b. Cycle the burner on-off several times to assure the switch will not cause nuisance shutdowns as the burner ignites.

- 4.5 FINAL CO<sub>2</sub> AND CO ANALYSIS - With gas input rate established, perform a final CO<sub>2</sub> analysis and make air adjustments as necessary. The final air settings should produce a flue gas analysis of between 8-1/2% and 9-1/2% CO<sub>2</sub> without CO.



Do not set fire visually on forced draft burners. Instruments are the only safe and reliable means to determine the proper adjustments.

**4.6 MOTOR RUNNING CURRENT AND VOLTAGE CHECK**

- a. Measure motor running current after final air adjustments have been made.

Current should not exceed motor service factor amps shown on motor nameplate.

- b. Check control voltage on terminals 1 and 2 as motor starts. Voltage should not drop below 102 volts [even momentarily] or difficulty may occur in control operation. Extreme voltage drop indicates inadequate service wire size to the burner.

**4.7 BURNER SAFETY CHECK**

- a. Start and stop the burner several times to insure proper operation. Check for proper functioning of low-water cutoff, high limit and/or operating control.
- b. Check operation of flame safeguard by stimulating a flame failure, making certain the burner locks out on safety within the time limits of the control.
- c. Using burner operation sequence, start the burner in accordance with the step by step operating sequence procedure. As the burner enters the flame safeguard sequence, verify each burner function at the timing indicated.

- 4.8 NORMAL OPERATION- Providing the setup and checkout operations outlined in Items 4 through 4.7 above have been properly completed and all tests have been found to be satisfactory, the burner is now ready for normal gas firing operation.

**GAS FIRING NOTES:** \_\_\_\_\_  
 \_\_\_\_\_  
 \_\_\_\_\_  
 \_\_\_\_\_  
 \_\_\_\_\_  
 \_\_\_\_\_



**CAUTION**

One of the most common oversights by an installer is failure to purge air, water, rust or other foreign matter from the Oil System. **DAMAGE TO PUMPS AND OTHER COMPONENTS CAUSED BY RUST, WATER OR FOREIGN PARTICLES IS NOT COVERED BY WARRANTY.**

A standard method for purging is to remove the system pressure gauge [or plug where gauge would normally be installed] and temporarily install a piece of copper tubing long enough to drain into a bucket or other container. The pump motor starter contacts are then manually depressed with a piece of wood or other nonconductor device and the pump allowed to run until purging is complete. There must be no sign of air, water, rust or other foreign matter in the flow.

If flow is not established within 2 minutes, the pump should be primed through the suction line. Reinstall gauge or plug after purge is complete.

**5. OIL BURNERS - [See Par.4 for Gas Burners]**

**5.1 REVIEW BURNER MATERIAL LIST IN THE INSTRUCTIONS MANUAL AND ANNOTATE THE FOLLOWING INFORMATION:**

- a. Oil Firing Rate [GPH]
- b. Oil Pressure at Nozzle [PSIG]
- c. Bypass Oil Pressure [PSIG]

**NOTE**

The above information is pertinent to setting up the burner.

**5.2 START-UP SETTINGS OF BURNER CONTROLS -** Using the burner operating sequence, proceed up to the step where the manual oil valves are to be opened.

**WARNING**

During initial start-up the operator must be on constant alert for emergency conditions such as fuel leaks, electrical malfunctions, etc. The location of all manual shutoff valves and switches should be clearly in mind so the burner can be quickly shut down if necessary. Should the burner fail to ignite, never manually manipulate the flame safeguard sequence which provides for purging of the combustion chamber.

**5.3 Using the Manufacturers' Instructions Bulletin on the flame safeguard, proceed with checkout**

to insure proper function of the safeguard under burner operational conditions. Table 8-2 shows those checks that should be performed.

**NOTE**

While performing these checks, certain adjustments and readings must be made at the appropriate time. These include, but are not limited to:

- a. Burner Combustion Air
- b. Oil Pressure [supply and bypass]. Pressure controlled by oil pressure regulator and oil metering valve settings.
- c. Boiler Limit Controls
- d. Draft Controls
- e. Other Controls electrically interlocked with the burner control system.
- f. CO<sub>2</sub> and smoke
- g. Stack Temperature

**5.4 FINAL CO<sub>2</sub> AND SMOKE ANALYSIS**

**CAUTION**

Do not set fire visually on forced draft burners. Instruments are the only safe and reliable means to determine the proper adjustment.

- a. **IF STRAIGHT OIL BURNER -** Perform a final CO<sub>2</sub> analysis and make air adjustments as necessary. The final settings should produce a flue gas analysis of between 10% and 12-1/2% CO<sub>2</sub> without smoke.

The Items Below Summarize the Flame Safeguard Checkout Tests Required for Each Type of Installation	
Checkout Item	When Performed
1. Preliminary Inspection	For All Installations
2. Flame Signal Measurement	For All Installations
3. Initial Lightoff Check with Proven Pilot	If Pilot Must be Proven Before the Main Fuel Valve Can Open
4. Pilot Turndown Test	If Pilot Must be Proven Before the Main Fuel Valve Can Open
5. Hot Refractory Hold-In Test	For All Photocell (Rectifying or Infrared Lead Sulfide) Applications
6. Hot Refractory Over-ride Test	For All Infrared (Lead Sulfide Photocell) Detector Applications
7. Ignition Spark Response Test	For All Ultraviolet Detector Applications
8. Flame Signal with Hot Combustion Chamber	For All Installations
9. Safety Switch Lockout Test	For All Installations

Table 8-2 Flame Safeguard Checkout Summary

**b. IF COMBINATION GAS-OIL BURNER -**

Leave air adjustments set as they were for gas firing and adjust the high fire supply oil pressure to obtain a flue gas analysis of between 10% and 12-1/2% CO<sub>2</sub> without smoke.

**NOTE**

Above method of setting up combination burners assures a smooth transfer between fuels without further adjustments and allows for simplified capacity calculations.

5.5 LOW OIL PRESSURE SWITCH - If burner is equipped with a low oil pressure switch, it should be adjusted so that it will recycle (or shut-down) the burner when oil pressure drops by 15 to 25%.

**SIMPLEX OIL SYSTEMS F1, F4B, F4H, F4S, F6 & F6R**

**NOTE**

With exception of "F1", these oil systems have low fire start.

- a. After the low and high fire rates have been established and recorded, set the low oil pressure switch 10 to 15% below the low fire rate (pressure).
- b. With the burner at low fire, slowly adjust the oil pressure regulator to a lower pressure making sure the low oil pressure switch recycles (or shuts down) the burner as the pressure drops below the setting.
- c. Adjust the oil pressure regulator so that the firing rates (pressures) that were recorded in step a. are restored.

**BYPASSING OIL SYSTEMS F7 AND F7T**

**NOTE**

These oil systems operate at 300 PSIG.

- a. Set the low oil pressure switch at 270 PSI.
- b. With the burner at low fire, slowly adjust the oil pressure regulator to a lower pressure making sure the low oil pressure switch recycles (or shuts down) the burner as the pressure drops below 270 PSIG as read on the oil pressure gauge at the oil drawer assembly.
- c. Adjust the oil pressure regulator so that the firing rate (pressure) of 300 PSIG is restored.

**5.6 CLEANING OF OIL SYSTEM COMPONENTS AFTER START-UP**

**NOTE**

It is not uncommon for the oil system components to become dirty or clogged during initial start-up as foreign matter from the oil lines is pumped through the system.

**WARNING**

Turn OFF the main manual fuel shut-off valves including pilot gas cock, if applicable. If a multi-fuel burner, shut OFF all fuels.

Turn OFF all electrical disconnects to the burner and any other equipment or systems electrically interlocked with the burner.

- a. Remove oil drawer assembly, disassemble oil nozzle and clean using solvent and wooden toothpick to avoid damage to the finely machined surfaces.
- b. Reassemble oil nozzle and replace oil drawer assembly.

**NOTE**

Other components such as oil pressure regulators, check valves and strainers should also be disassembled and cleaned.

- c. Restore manual fuel valves and electrical disconnects to ON.

**5.7 MOTOR RUNNING CURRENT AND VOLTAGE CHECK**

- a. Measure motor running current after final air adjustments have been made. Current should not exceed motor service factor amps shown on motor nameplate.
- b. Check control voltage on terminals 1 and 2 as motor starts. Voltage should not drop below 102 volts [even momentarily] or difficulty may occur in control operation. Extreme voltage drop indicates inadequate service wire size to the burner.

**5.8 BURNER SAFETY CHECK**

- a. Start and stop the burner several times to insure proper operation. Check for proper functioning of low-water cutoff, high limit and/or operating control.
- b. Check operation of flame safeguard by stimulating a flame failure, making certain the burner locks out on safety within the time limits of the control.
- c. Using burner operating sequence, start the burner in accordance with the step by step operating sequence procedure. As the burner enters the flame safeguard sequence, verify each burner function at the timing indicated.

**5.9 NORMAL OPERATION** - Providing the set-up and checkout operations outlined in Items 5 thru 5.8 have been properly completed and all tests have been found to be satisfactory, the burner is now ready for normal oil firing operations.

**OIL FIRING NOTES:** \_\_\_\_\_  
\_\_\_\_\_  
\_\_\_\_\_  
\_\_\_\_\_  
\_\_\_\_\_  
\_\_\_\_\_  
\_\_\_\_\_  
\_\_\_\_\_  
\_\_\_\_\_  
\_\_\_\_\_  
\_\_\_\_\_  
\_\_\_\_\_

# PART IX

## MAINTENANCE

### NOTE

After the burner has been started and adjusted by your installer, linkage settings, fuel pressures and control settings should not be changed or tampered with by persons not thoroughly experienced with the burner and control system. Service calls caused by “tinkeritis” or poor maintenance procedure are not covered by any guarantee or service plan.

### GENERAL MAINTENANCE

1. Keep the boiler, burner and entire boiler room clean. A clean boiler room is essential to first class boiler operation.
2. Keep the burner and boiler control covers in place. The electrical contacts in the controls are very sensitive.
3. Never close vents supplying air to the boiler room. If cold air currents cause difficulty with other boiler room equipment, air ducts should be installed to direct the flow of fresh air.
4. Repair all leaks promptly. All piping connections to the boiler and burner should be maintained leak proof because even a minor leak, if neglected, may soon become serious.
5. Foaming or priming may occur in a steam boiler and cause large quantities of water to pass over into the steam main. It can be detected by violent fluctuations or sudden dropping of the water level in the sight glass. This will result in nuisance shutdowns of the burner due to the sudden dropping of the water level causing the low water cutoff to shut off the burner.

This trouble may be caused by dirt or oil in the boiler water, an overdose of boiler compounds, carrying too high a water level in the boiler or a high overload on the boiler. In case of serious trouble, stop the burner and decrease the load on the boiler. Then correct the condition according to the boiler manufacturer's instructions.

### DAILY MAINTENANCE

1. Check boiler water level in the sight glass and the steam pressure on the gauge to the steam boilers. Check temperature reading and water pressure on hot water boilers.

2. Check the low water cutoff operation by opening the blow down valve on the low water cutoff to remove rust and dirt and determine that the burner cuts out with low water in the sight glass. Immediate corrective action must be taken if burner does not cut off with low water in the sight glass.
3. Turn off burner control switch and close pilot manual gas cock. Turn on burner control switch and determine that burner flame safeguard locks out on flame failure before the main gas valve is energized. Immediate corrective action must be taken if flame safeguard does not lock out to indicate flame failure.
4. Observe the operation of the boiler limit and operating controls to determine that the burner is being cut off at the proper setting. Adjust per the manufacturer's instruction sheet as required.

### WEEKLY MAINTENANCE

1. Check all burner linkages. Tighten if necessary.
2. Test the low water cutoff by opening the boiler blow down valve to remove rust and dirt from the boiler mud leg or drum and determine that the burner cuts off when low water point is reached in the sight glass.
3. Check all phases of the operation of the control circuit for proper operation.
4. Operate burner manual shutoff valves to determine that they are working freely and properly. Lubricate if necessary.
5. Perform all tests and inspections required under “Daily Maintenance”.

## MONTHLY MAINTENANCE

1. Check pilot assembly.
  - a. The ignition electrode must be centered in the ignitor body.
  - b. The ignition electrode and pilot assembly should be inspected and cleaned if necessary.
  - c. The high tension wire between the transformer and the ignition electrode should be checked for deterioration.
  - d. The flame scanner should be inspected and cleaned if necessary.
2. Check air dampers for smooth operation. Remove accumulation of lint or dirt.
3. Test boiler safety valves.
4. Oil firing.
  - a. Check ignition electrodes. Clean if necessary.
  - b. Clean oil atomizing nozzle if necessary.
  - c. Inspect oil filters. Replace or clean filter cartridge if necessary.
  - d. Inspect filter on air compressor. (If used)
5. Lubricate motors in accordance with motor manufacturer's instructions.
6. Perform all tests and inspections required under "Weekly Maintenance".

## ANNUAL MAINTENANCE

1. Have the burner inspected and checked by a qualified service representative.
2. If the boiler is to be out of service for the summer close all manual valves. Turn off burner by control switch, being sure to leave electrical power on the control panel. Leaving power on the control panel will prevent humidity damage to the flame safeguard.

## PERIODIC TESTING RECOMMENDED CHECK LIST

ITEM	FREQUENCY	ACCOMPLISHED	REMARKS
Check burner and boiler control linkage	Daily	Operator	Make visual inspection
Check fuel system for leaks	Daily	Operator	Make inspection visually and with leak detection instrumentation
Gauges, monitors and indicators	Daily	Operator	Make visual inspection and record readings in log
Oil pump inlet vacuum	Daily	Operator	Make visual inspection and record readings in log
Oil pressure at pump, burner, and/or regulating valve	Daily	Operator	Make visual inspection and record readings in log
Instrument and equipment	Daily	Operator	Make visual check against recommended specifications
Check burner flame	Daily	Operator	Visual inspection for changes
Firing rate control	Weekly Semiannually Annually	Operator Service technician Service technician	Verify factory settings Verify factory settings Check with combustion test
Stack temperature	Daily	Operator	Record in log
Flue, vent, stack or outlet dampers	Monthly	Operator	Make visual inspection of linkage, check for proper operation
Igniter	Weekly	Operator	Make visual inspection, check flame signal strength if meterfitted (See " Combustion safety controls")
Oil nozzle(s) and strainers	Semiannually	Operator	Check for dirt and wear
Fuel valves			
Pilot and main	Weekly	Operator	Open limit switch - make aural and visual check - check valve position indicators and check fuel meters if so fitted
Pilot and main gas or main oil	Annually	Service technician	Perform leakage tests - refer to instructions
Combustion safety controls			
Flame failure	Weekly	Operator	Close manual fuel supply for (1) pilot, (2) main fuel cock, and/or valve(s); check safety shutdown timing; log
Flame signal strength	Weekly	Operator	If flame signal meter installed, read and log; for both pilot and main flames, notify service organization if readings are very high, very low, or fluctuating; refer to instructions
Pilot turndown tests	As required/annually	Service technician	Required after any adjustments to flame scanner mount or pilot burner verify annually - refer to instructions
Refractory hold in	As required/annually	Service technician	See "Pilot turndown tests"

## PERIODIC TESTING RECOMMENDED CHECK LIST

ITEM	FREQUENCY	ACCOMPLISHED	REMARKS
Low-water fuel cutoff and alarm	Daily/Weekly Semiannually	Operator Operator	Refer to instructions Perform a slow drain test in accordance with ASME Boiler and Pressure Vessel Code Section VI
High limit safety control	Annually	Service technician	Refer to instructions
Operating control	Annually	Service technician	Refer to instructions
Low draft, fan, air pressure, and damper position interlocks	Monthly	Operator	Refer to instructions
High and low gas pressure interlocks	Monthly	Operator	Refer to instructions
High and low oil pressure interlocks	Monthly	Operator	Refer to instructions
High and low oil temperature interlocks	Monthly	Operator	Refer to instructions
Fuel valve interlock switch	Annually	Service technician	Refer to instructions
Purge switch	Annually	Service technician	Refer to instructions
Burner position interlock	Annually	Service technician	Refer to instructions
Low fire start interlock	Annually	Service technician	Refer to instructions
Automatic changeover control (dual fuel)	At least annually	Service technician	Under supervision of gas utility
Safety valves	As required	Operator	In accordance with procedure in Section VI, ASME Boiler and Pressure Vessel Code, Recommended Rules for Care and Operation of Heating Boilers
Inspect burner components	Semiannually	Service technician	Refer to instructions
Clean burner fan	Annually or as required	Operator	Remove buildup on fan blades

# PART X ILLUSTRATED PARTS BREAKDOWN

## Notice

*Always Include U. L. SERIAL NUMBER When Ordering Parts !*

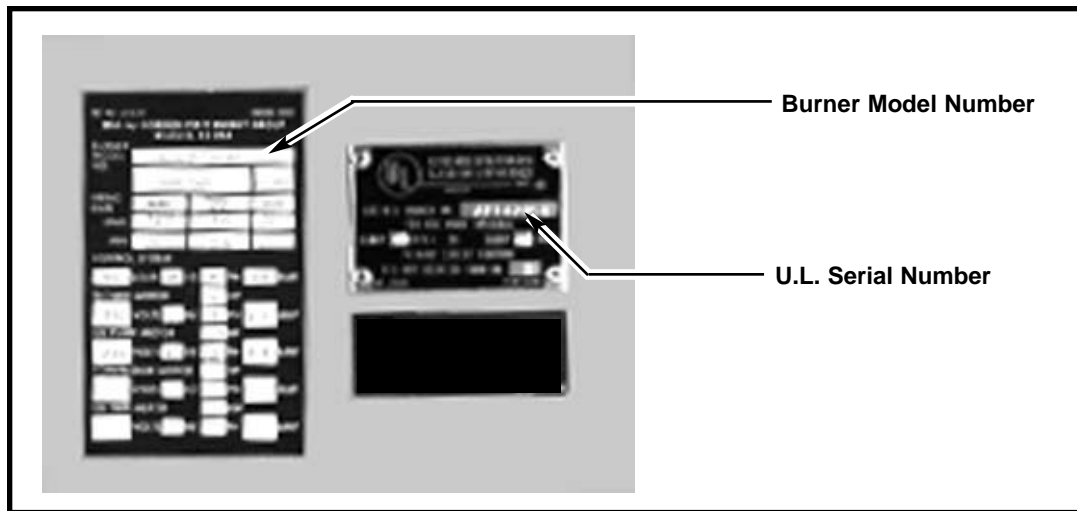

### HOW TO ORDER PARTS

Parts should be ordered from the authorized service representative who started and adjusted your burner. When ordering parts, the following guidelines should be used.

1. Always include burner serial number as shown on the U. L. label located on the burner housing.
2. If parts are required for electric controls, motors, pumps, etc., also include complete nameplate data taken from the item for which the parts are required.
3. List the complete name and description of each part included in your order. Refer to the following illustration and particularly to the burner material list which accompanied your burner. List any specific characteristics such as size, voltage rating, etc.
4. State quantity desired of each item.
5. State whether shipment is to be made by express, parcel post or freight.



## TYPICAL R6 or R8 GAS-OIL BURNER

**NOTE** SEE PART IV FOR GAS SYSTEM COMPONENTS, PART V FOR OIL SYSTEM COMPONENTS AND PART VI FOR COMBUSTION CONTROLS.

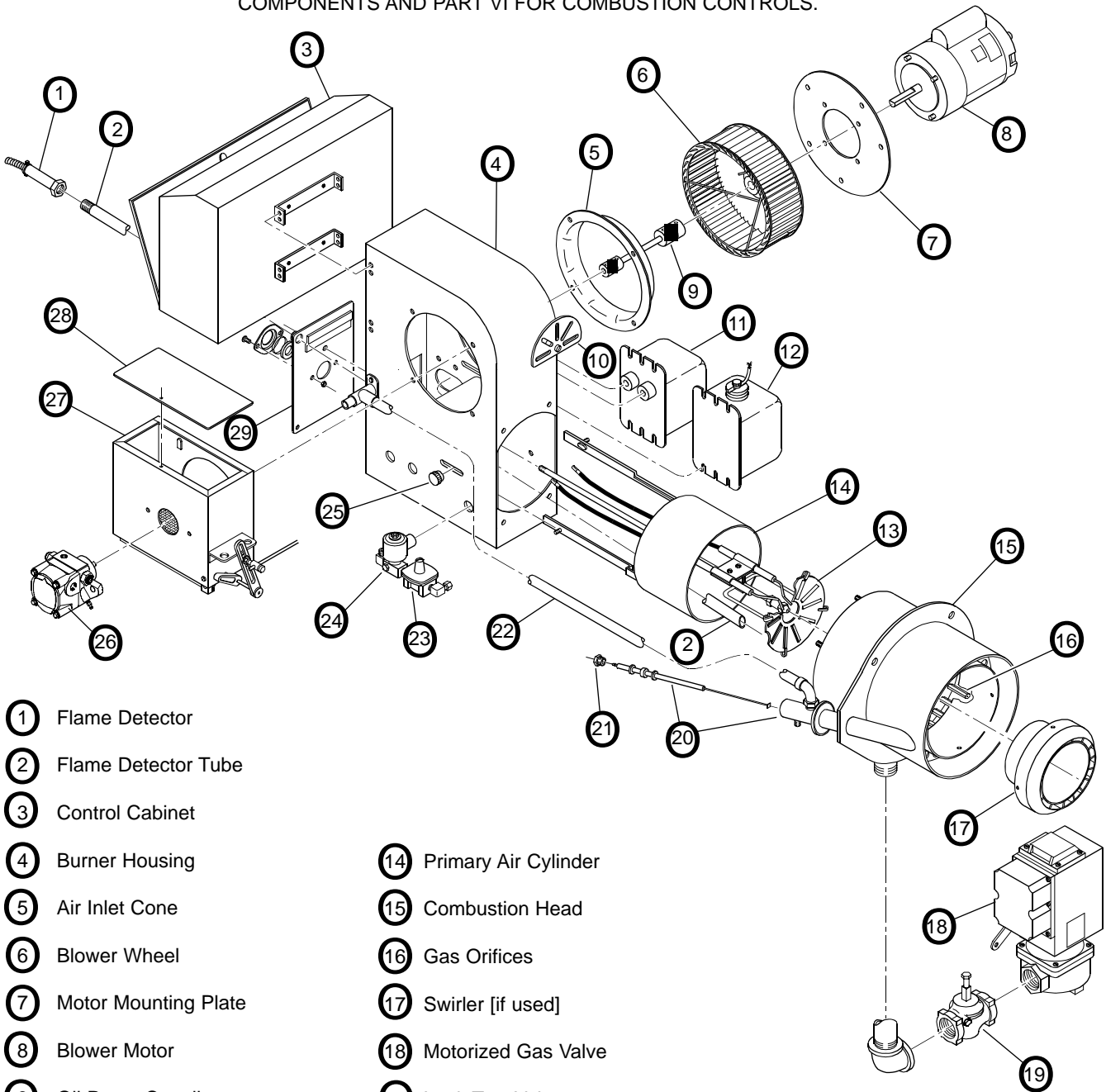

- |                                      |                                 |  |
|--------------------------------------|---------------------------------|--|
| ① Flame Detector                     | ⑭ Primary Air Cylinder          | ⑲ Leak Test Valve                      |
| ② Flame Detector Tube                | ⑮ Combustion Head               | ⑳ 216C Gas Pilot Electrode Assembly    |
| ③ Control Cabinet                    | ⑯ Gas Orifices                  | ㉑ 216C Pilot Packing Nut               |
| ④ Burner Housing                     | ⑰ Swirler [if used]             | ㉒ Pilot Air Tube                       |
| ⑤ Air Inlet Cone                     | ⑱ Motorized Gas Valve           | ㉓ Pilot Gas Pressure Regulator         |
| ⑥ Blower Wheel                       | ⑳ Oil Pump                      | ㉔ Pilot Solenoid Valve                 |
| ⑦ Motor Mounting Plate               | ㉑ Air Inlet Assembly            | ㉕ Primary Air Positioning Control Knob |
| ⑧ Blower Motor                       | ■ Air Louver                    |  |
| ⑨ Oil Pump Coupling                  | ■ Air Louver Spring             |  |
| ⑩ Linkage Control Quadrant           | ■ Oil Cylinder Mounting Bracket |  |
| ⑪ Oil Ignition Transformer [if used] | ■ Louver Actuator Arm           |  |
| ⑫ Gas Pilot Ignition Transformer     | ■ Air Inlet Guard               |  |
| ⑬ Oil Drawer Assembly                | ⑳ Air Inlet Box Cover           |  |
| ■ Air Diffuser                       | ㉑ Back Plate Assembly           |  |
| ■ Oil Nozzle                         |                                 |  |
| ■ Oil Nozzle Adapter                 |                                 |  |
| ■ Oil Ignition Electrodes [if used]  |                                 |  |
| ■ Main Fuel Tube                     |                                 |  |
| ■ Ignition Cables [if used]          |                                 |  |

## TYPICAL R10 or R12 GAS-OIL BURNER

**NOTE**

SEE PART IV FOR GAS SYSTEM COMPONENTS, PART V FOR OIL SYSTEM COMPONENTS AND PART VI FOR COMBUSTION CONTROLS.

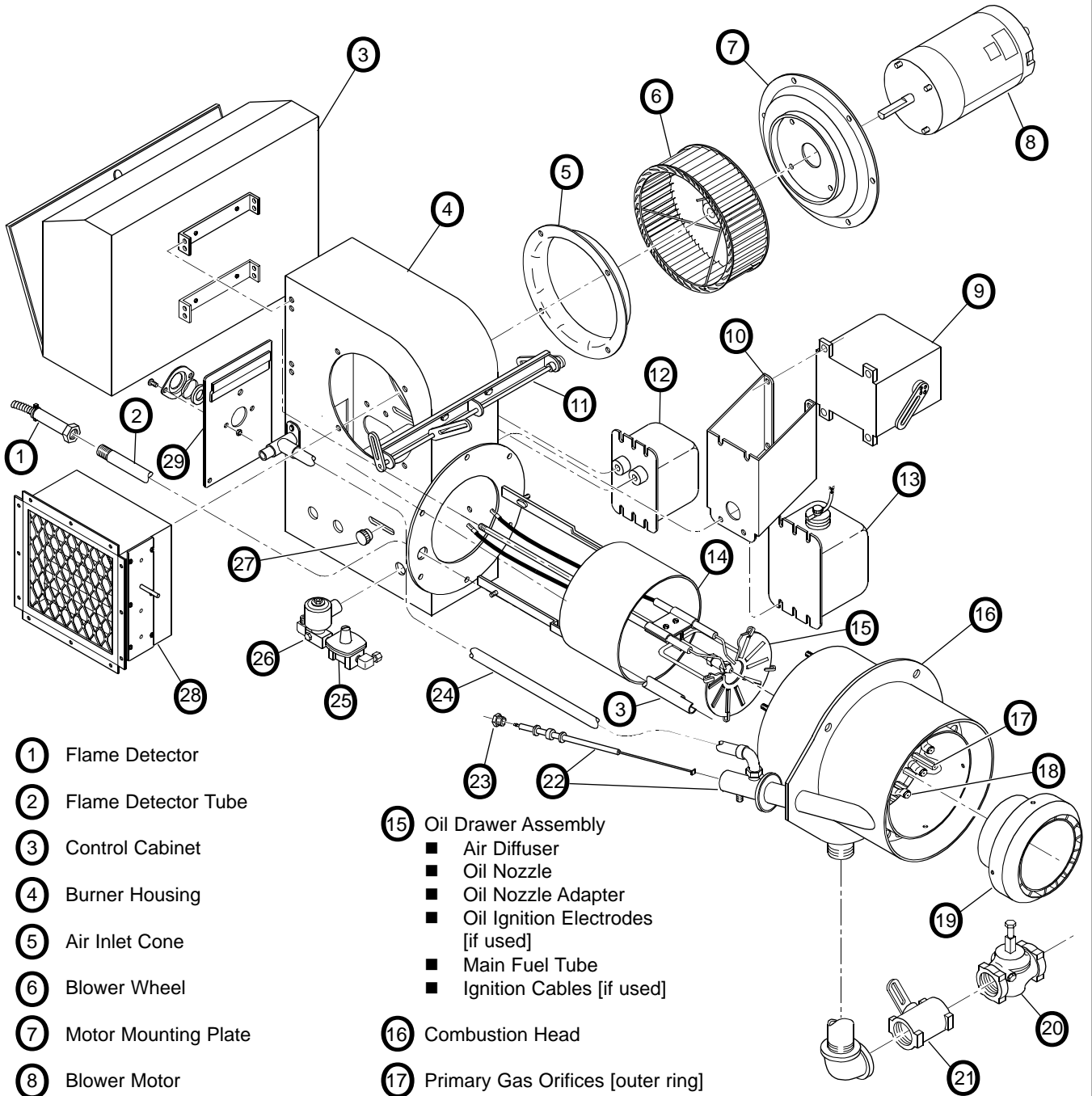

- |    |                                    |    |                                   |    |                                      |
|----|------------------------------------|----|-----------------------------------|----|--------------------------------------|
| 1  | Flame Detector                     | 15 | Oil Drawer Assembly               | 24 | Pilot Air Tube                       |
| 2  | Flame Detector Tube                | ■  | Air Diffuser                      | 25 | Pilot Gas Pressure Regulator         |
| 3  | Control Cabinet                    | ■  | Oil Nozzle                        | 26 | Pilot Gas Solenoid Valve             |
| 4  | Burner Housing                     | ■  | Oil Nozzle Adapter                | 27 | Primary Air Positioning Control Knob |
| 5  | Air Inlet Cone                     | ■  | Oil Ignition Electrodes [if used] | 28 | Air Inlet Assembly                   |
| 6  | Blower Wheel                       | ■  | Main Fuel Tube                    | 29 | Back Plate Assembly                  |
| 7  | Motor Mounting Plate               | ■  | Ignition Cables [if used]         |    |                                      |
| 8  | Blower Motor                       | 16 | Combustion Head                   |    |                                      |
| 9  | Modulating Motor                   | 17 | Primary Gas Orifices [outer ring] |    |                                      |
| 10 | Modulating Motor Mounting Bracket  | 18 | Secondary Gas Orifices [if used]  |    |                                      |
| 11 | Linkage Control Jackshaft          | 19 | Swirler                           |    |                                      |
| 12 | Oil Ignition Transformer [if used] | 20 | Leak Test Valve                   |    |                                      |
| 13 | Gas Pilot Ignition Transformer     | 21 | Butterfly Gas Valve               |    |                                      |
| 14 | Primary Air Cylinder               | 22 | 216C Gas Pilot Electrode Assembly |    |                                      |
|    |                                    | 23 | 216C Pilot Packing Nut            |    |                                      |

## TYPICAL S6, S7 or S8 GAS-OIL BURNER

**NOTE** SEE PART IV FOR GAS SYSTEM COMPONENTS, PART V FOR OIL SYSTEM COMPONENTS AND PART VI FOR COMBUSTION CONTROLS.

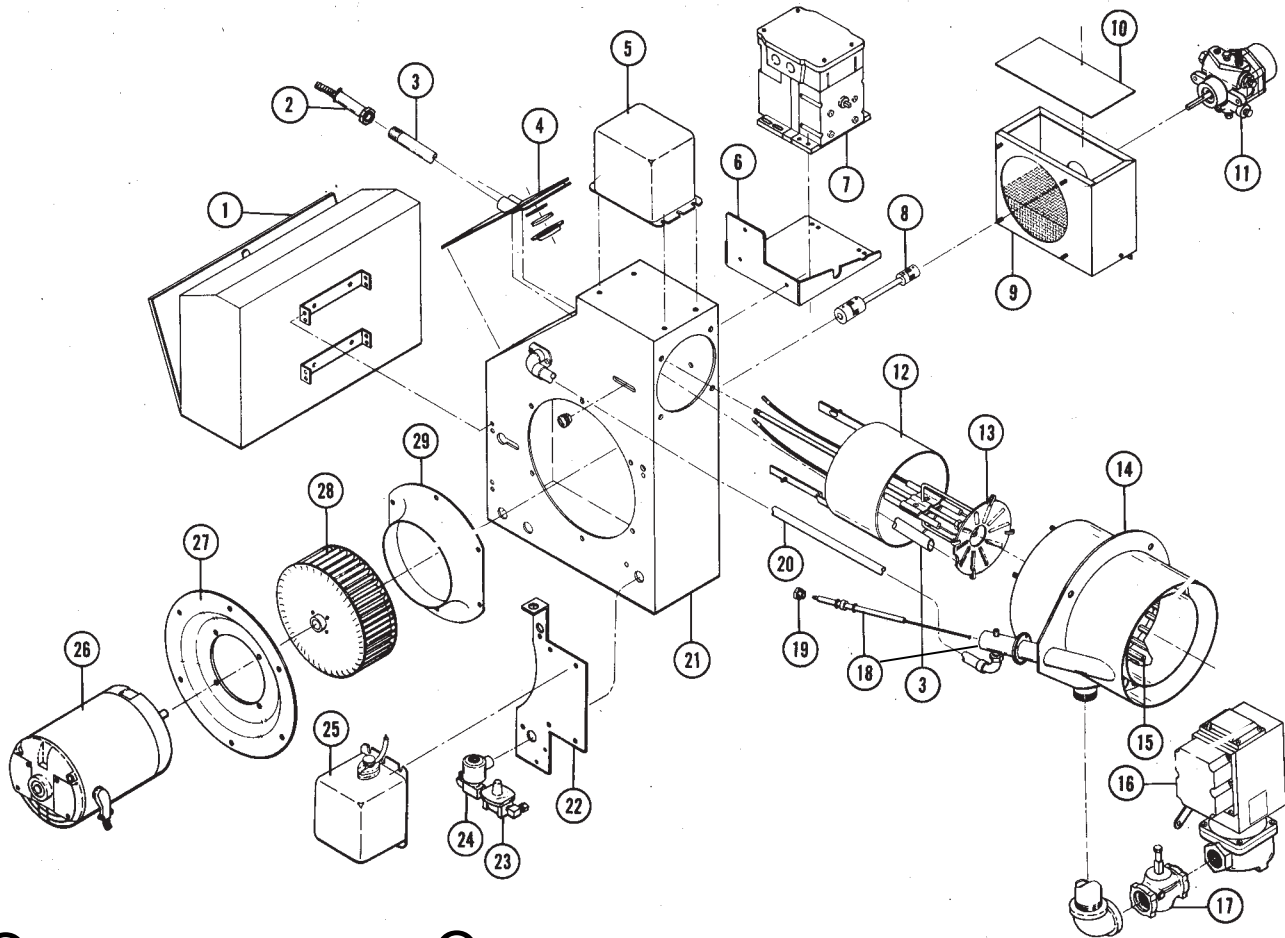

- |   |                                     |                                  |
|---|-------------------------------------|----------------------------------|
| ① Control Cabinet                             | ⑪ Oil Pump                          | ⑳ Pilot Air Tube                 |
| ② Flame Detector                              | ⑫ Primary Air Cylinder              | ㉑ Burner Housing                 |
| ③ Flame Detector Tube                         | ⑬ Oil Drawer Assembly               | ㉒ Transformer Mounting Bracket   |
| ④ Back Plate Assembly                         | ■ Air Diffuser                      | ㉓ Pilot Gas Pressure Regulator   |
| ⑤ Oil Ignition Transformer (if used)          | ■ Oil Nozzle                        | ㉔ Pilot Solenoid Valve           |
| ⑥ Modulating Motor Mounting Bracket (if used) | ■ Oil Nozzle Adapter                | ㉕ Gas Pilot Ignition Transformer |
| ⑦ Modulating Motor (if used)                  | ■ Oil Ignition Electrodes (if used) | ㉖ Blower Motor                   |
| ⑧ Oil Pump Coupling                           | ■ Main Fuel Tube                    | ㉗ Motor Mounting Plate           |
| ⑨ Air Inlet Assembly                          | ■ Ignition Cables (if used)         | ㉘ Blower Wheel                   |
| ■ Air Louver                                  | ⑭ Combustion Head                   | ㉙ Air Inlet Cone                 |
| ■ Air Louver Spring                           | ⑮ Gas Orifices                      |                                  |
| ■ Oil Cylinder Mounting Bracket               | ⑯ Automatic Gas Valve               |                                  |
| ■ Louver Actuator Arm                         | ⑰ Leak Test Valve                   |                                  |
| ■ Air Inlet Guard                             | ⑱ 216C Gas Pilot Electrode Assembly |                                  |
| ⑩ Air Inlet Box Cover                         | ⑲ 216C Pilot Packing Nut            |                                  |

## TYPICAL S10 or S12 GAS-OIL BURNER

**NOTE**

SEE PART IV FOR GAS SYSTEM COMPONENTS, PART V FOR OIL SYSTEM COMPONENTS AND PART VI FOR COMBUSTION CONTROLS.

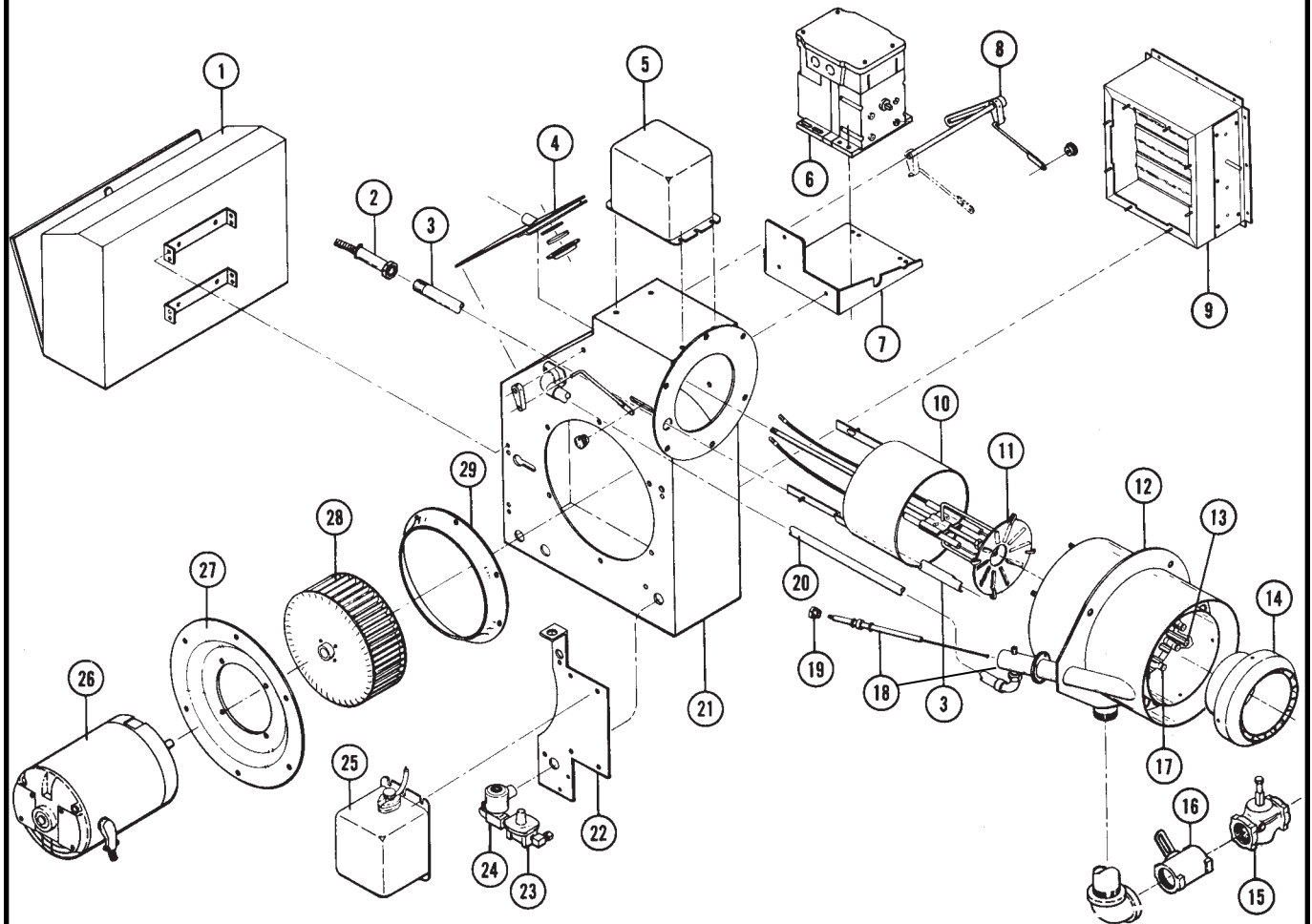

① Control Cabinet

② Flame Detector

③ Flame Detector Tube

④ Back Plate Assembly

⑤ Oil Ignition Transformer  
(if used)

⑥ Modulating Motor

⑦ Modulating Motor Mounting  
Bracket (if used)

⑧ Modulating Primary Air Cylinder  
Linkage Assembly

⑨ Air Inlet Assembly

⑩ Primary Air Cylinder

⑪ Oil Drawer Assembly

- Air Diffuser
- Oil Nozzle
- Oil Nozzle Adapter
- Oil Ignition Electrodes  
(if used)
- Main Fuel Tube
- Ignition Cables (if used)

⑫ Combustion Head

⑬ Primary Gas Orifices (outer ring)

⑭ Swirler

⑮ Leak Test Valve

⑯ Butterfly Gas Valve

⑰ Secondary Gas Orifices  
(inner ring)

⑱ 216C Gas Pilot Electrode  
Assembly

⑲ 216C Pilot Packing Nut

⑳ Pilot Air Tube

㉑ Burner Housing

㉒ Transformer Mounting Bracket

㉓ Pilot Gas Pressure Regulator

㉔ Pilot Solenoid Valve

㉕ Gas Pilot Ignition Transformer

㉖ Blower Motor

㉗ Motor Mounting Plate

㉘ Blower Wheel

㉙ Air Inlet Cone

# PART XI

## SUPPLEMENTARY DATA

**For replacement parts contact OEM Boiler Parts**

**[www.gordonpiatt.com](http://www.gordonpiatt.com)**

**717-367-9900**