

Model F Burner Instruction Manual

FOR
GAS AND AIR ATOMIZING LIGHT AND HEAVY OIL FUEL SYSTEMS
MANUFACTURED BY JOHN ZINK COMPANY, LLC

NOTE: YOUR BURNER MAY HAVE A LETTER PREFIX OR SUFFIX ADDED TO THE MODEL DESIGNATION. HOWEVER, THIS IS FOR IDENTIFICATION PURPOSES ONLY AND DOES NOT AFFECT THE INSTRUCTIONS IN THIS MANUAL.



For replacement parts contact OEM Boiler Parts

www.gordonpiatt.com

717-367-9900

MODEL F

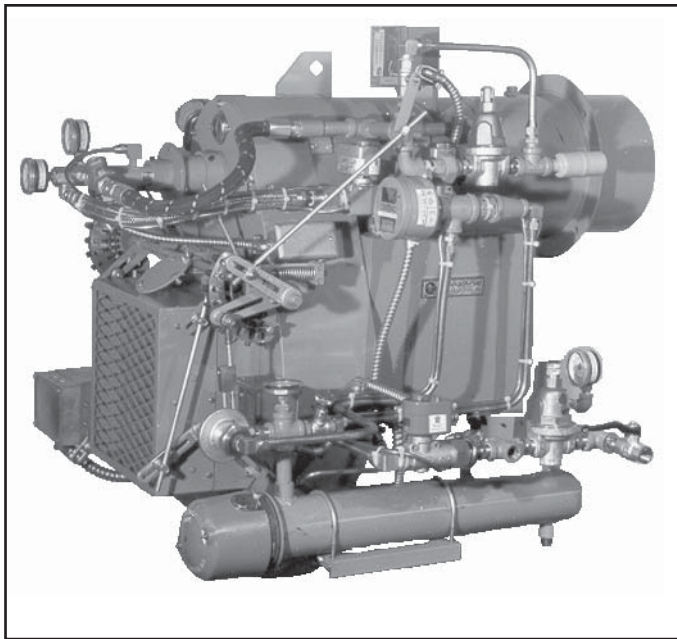

Model F Burner

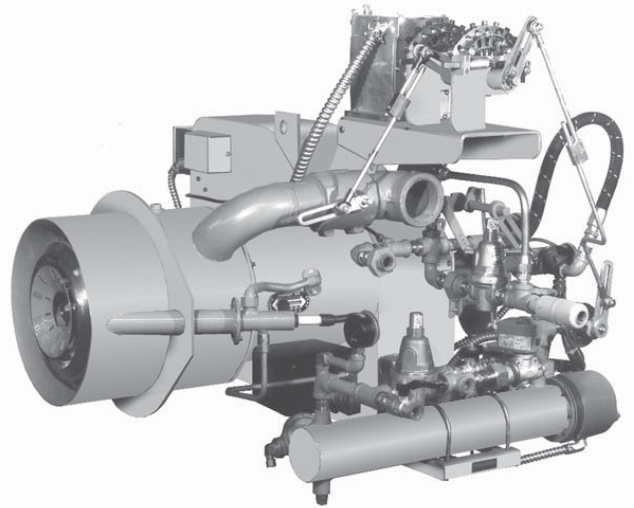

Model FL has low profile for use where space is limited or to avoid pitting in front of the boiler.

Model FL Burner

INTRODUCTION

- The instructions in this manual are applicable to the systems diagrammed in Figures 4-1, 4-2 and 4-3 where all illustrated equipment is supplied by John Zink Company, LLC.
- Oil pumping and loop regulating systems as well as compressed air sources supplied by others must be equal to the John Zink Company, LLC system in each instance or the burner performance will be compromised.

TABLE OF CONTENTS

PART I	- SUGGESTED INSTALLATION INSPECTION CHECKLIST	3
PART II	- GENERAL	4
PART III	- BURNER FAMILIARIZATION AND PRELIMINARY INSPECTION	5-11
PART IV	- SYSTEM DESCRIPTION	12-17
	General	12
	Gas Piping Information	12-13
	Compressor	14
	Oil Systems	14
	Light Oil	14-15
	Heavy Oil	14-17
PART V	- PRELIMINARY ADJUSTMENTS	18-35
	■ Oil Drawer Assembly	18-23
	■ Primary-Secondary Air Cylinder	24
	■ Air Louver Box	25
	■ Gas Pilot Ignitor Assembly	26-27
	Pilot Trouble Shooting	27-28
	■ Oil Metering Valve	28-29
	■ Low Oil Pressure Switch	30
	■ Oil Relief Valve	30-31
	■ Oil Pressure Reducing and Regulating Valve (Light Oil Only)	30-31
	■ Burner Oil Trim Electric Heater	31
	■ Burner Air Metering Bleed Valve	32
	■ Burner Air Pressure Regulating Valve	33
	■ Burner Low Air Pressure Switch	33
	■ Characterized Linkage	34
	■ Air Flow Switch	35
PART VI	- BURNER START-UP	36-43
	- Flame Safeguard Installation	36
	- Identification of Controls	36-37
	- Gas Burners	37-39
	- Air Atomizing Oil Burners	39-43
PART VII	- TROUBLE SHOOTING	44-49
	- Periodic Testing Recommended Check List	46-47
	- Notes	48-49
PART VIII	- SUPPLEMENTARY DATA	50
PART IX	- HOW TO ORDER PARTS	51

WARNINGS

If you smell gas:

1. Extinguish any open flame.
2. Turn off gas supply to burner.
3. Open windows.
4. Don't touch electrical switches.
5. EVACUATE people from building.
6. Immediately call the gas supplier.

The use and storage of gasoline or other flammable liquids and vapors in open containers in the vicinity of this appliance is hazardous.

In accordance with OSHA standard 1910.147, all equipment, machines and processes shall be locked out prior to servicing.

If not installed, vented, operated and maintained in accordance with the manufacturer's instructions, this product could expose you to substances in fuel or from fuel combustion which can cause death or serious illness and which are known to the State of California to cause cancer, birth defects or other reproductive harm.

Improper servicing of this equipment may create a potential hazard to equipment and operators.

SERVICING MUST BE DONE ONLY BY FULLY TRAINED AND QUALIFIED PERSONNEL.

Before disconnecting or opening up a fuel line and before cleaning or replacing parts of any kind.

- Turn **OFF** the manual fuel shutoff valves including pilot gas cock, if applicable. If a multiple fuel burner, shut **OFF** all fuels.
- Turn **OFF** all electrical disconnects to the burner and any other equipment or systems electrically interlocked with the burner.

Do **NOT** use TEFLON TAPE or compounds with TEFLON content as an oil or gas pipe sealant. TEFLON can cause valves to fail creating a SAFETY HAZARD. Warranties are nullified and liability rests solely with the installer when evidence of TEFLON is found.

PART I

SUGGESTED INSTALLATION INSPECTION CHECKLIST

CHECK WHEN COMPLETED

GENERAL

- Is burner installed in accordance with applicable installation drawings?
- If a refractory combustion chamber is part of the installation, is it completely dry, cured, and ready for firing at full boiler input?
- Has the proper electrical voltage been connected to the burner control cabinet as shown on the burner material list?
- Has the burner wiring been checked for completeness and accuracy? Have 3-phase motors been properly wired and checked for correct rotation?
- Are the boiler mounted limit controls such as low water cutoffs, high limit controls, operating controls, modulating controls, etc., properly installed and wired?
- Are the boiler controls the right type and range for the installation?
- Is the boiler water supply, including feed pumps, properly connected and is boiler filled with water?
- Is sufficient plant load available to the boiler so that it can be fired continuously and held at full rating for at least 10 minutes to properly adjust the burner fuel – air ratio?
- If boiler load is not connected, can steam be vented so that boiler can be fired continuously at full rating without endangering personnel or equipment? Is there adequate make-up water when steam is vented?
- If the installation is a hot water boiler, have the circulating pumps been completely installed, wired, and tested to assure proper operation so that the burner can be fired continuously at full rating for at least 10 minutes?
- For new boiler installations, has the boiler been boiled out in accordance with the boiler manufacturer's instructions?
- Have the boiler breeching connections to the stack been completed and are they open and unobstructed?
- Is draft control equipment required and, if so, installed?
- Have adequate provisions for combustion air been installed?
- Have the persons listed below been notified of the burner start-up date?
 - Owner's Representative
 - Mechanical Contractor's Representative
 - Electrical Contractor's Representative
 - Service Organization's Representative
 - Boiler Manufacturer's Representative

- Is all specified auxiliary equipment mounted, wired and operational? This may include outdoor temperature controls, oil flow switches, space thermostats, water flow switches, motorized combustion air louvers, etc.

GAS FIRING

- Are all gas train components installed and have they been properly selected, sized and assembled?
- Have properly sized vent lines been installed on all gas train components which require venting? This includes such items as pressure regulators, normally open vent valves, diaphragm valves, low and high gas pressure switches, etc.
- Have gas train piping and components been tested and proven gas tight?
- Have the gas lines been purged?
- Is the proper gas pressure available at the inlet to the controls which meets the requirement shown on the burner material list?

OIL FIRING

- Is the oil tank installed and filled with the proper type and grade of fuel oil as required by the burner material list? (There must positively be no water in the tank!)
- Is the proper oil pressure, temperature and viscosity available at the inlet to the controls which meets the requirements shown on the burner material list and/or oil system sheet?
- Have oil supply and return lines been properly sized to meet the maximum pumping capacity of the pump and has the system been purged and proven leak proof?
- Is the oil system pipe for two-pipe operation as required and is the oil pump set-up for two-pipe operation?

NOTE

Some pumps require the use of an internal bypass plug for two-pipe operation.

- Does the air compressor have adequate lubricating oil?

PART II

GENERAL

NOTE

Installation requirements and instructions should always be covered in appropriate engineering drawings and specifications which detail the applicable building codes, etc. Information contained herein is to be used as a guide ONLY and not as the final authority.

- Starting a burner is an event which normally culminates the efforts of several different contractors, manufacturer's, utility and engineering concerns, sales and factory representatives, and others.
- In order for the burner to operate safely and meet its design capabilities, the interfacing fuel, air, electrical, exhaust and plant heating control systems must be properly sized, selected, installed and tested. Additionally, all conditions must be such that the heat generated by the burner can be safely used or wasted without endangering personnel or equipment.
- No responsibility is assumed by the manufacturer, or any of its employees, for any liability or damages caused by an inoperable, inadequate or unsafe burner condition which is the result, either directly or indirectly, of any of the improper or inadequate conditions described above.
- To insure that a safe and satisfactory installation has been made, a pre-start inspection is necessary. This inspection must be performed by an individual who is thoroughly familiar with all aspects of proper boiler/burner installation and how it interfaces with overall plant operation.
- Part I of this bulletin sets forth major inspection items that must be considered.

NOTE

This inspection should be performed before the burner start-up specialist is called in. An incomplete or inadequate installation may require additional time and effort by start-up personnel and cause an untimely and costly delay.

- The results of this inspection will often times identify corrections that must be made prior to start-up as well as point out potential or long range problems in plant operation if corrections are not made.
- Burner start-up is a serious matter and should not be viewed as a time for "crowd gathering" by unconcerned, uninformed or unauthorized personnel. The number of persons present should be held to an absolute minimum.
- Instruction of operating and other concerned personnel should be done after the burner has been successfully fired and adjusted by a qualified service agency or factory start-up specialist.

PART III

BURNER FAMILIARIZATION AND PRELIMINARY INSPECTION

BURNER FAMILIARIZATION

Study the following illustrations taking special note of the PART NAMES as shown in the call-outs.

Variations between systems are commonplace due to the many differences in job conditions and agency requirements.

This manual contains information applicable to a typical oil system arrangement and is not intended to be representative of any specific agency or code criteria.

PRELIMINARY INSPECTION

The burner should be visually checked for damage and loose components as these conditions can occur during shipment, through improper handling, by tampering or through improper care and storage at the job site.

CHECK FOR:

- Obvious damage to housing, air inlet, and components mounted thereon.
- Tightness of fasteners, tube fittings, plugs, etc.
- Tightness of electrical terminals and connections.
- Tightness of adjustment mechanisms such as ball-joint swivel connectors and control arms.
- Accumulations of oil, dust, dirt, water or other foreign matter on, in, or near the burner.

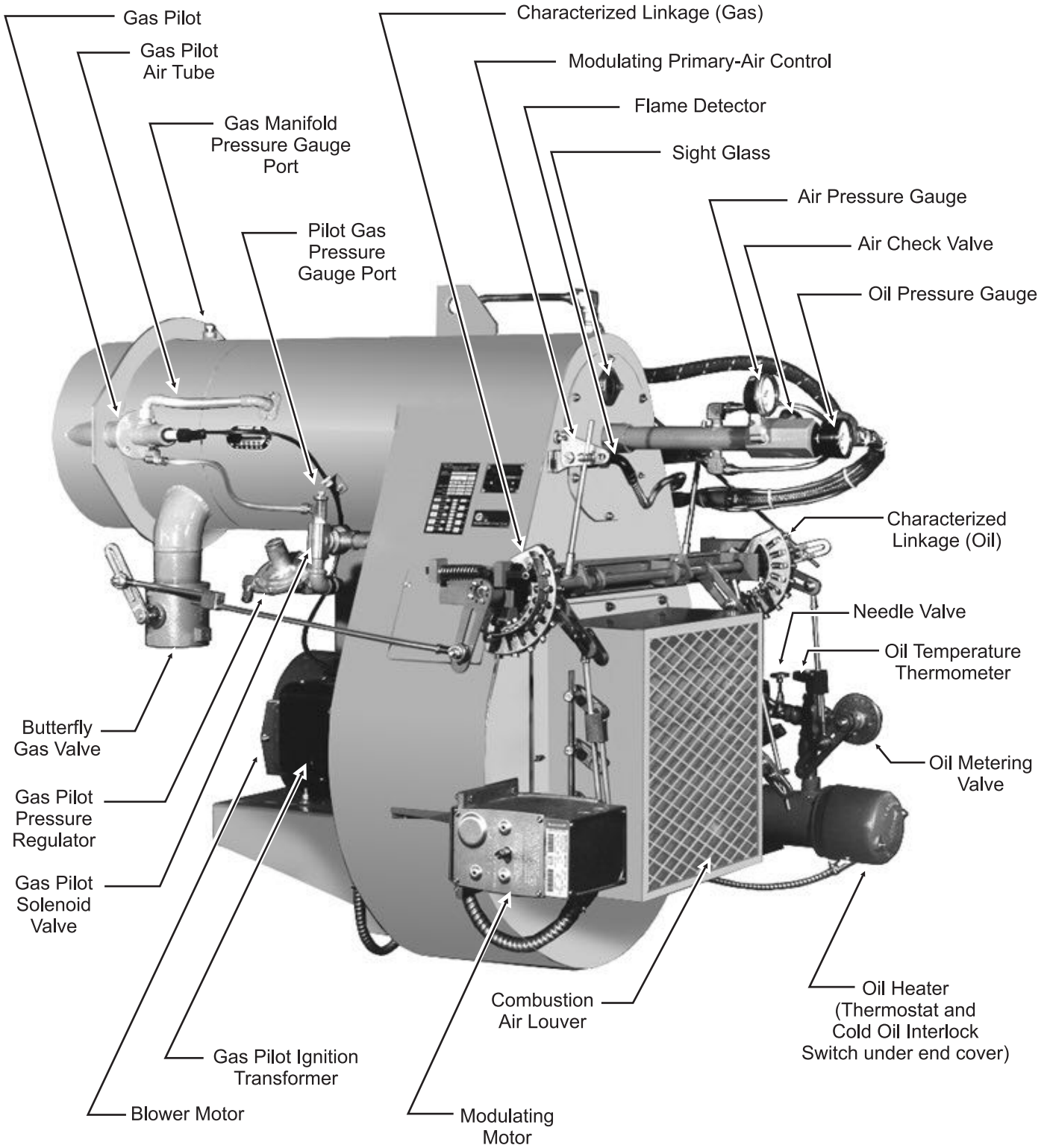

TYPICAL MODEL F WITH HEAVY OIL SYSTEM

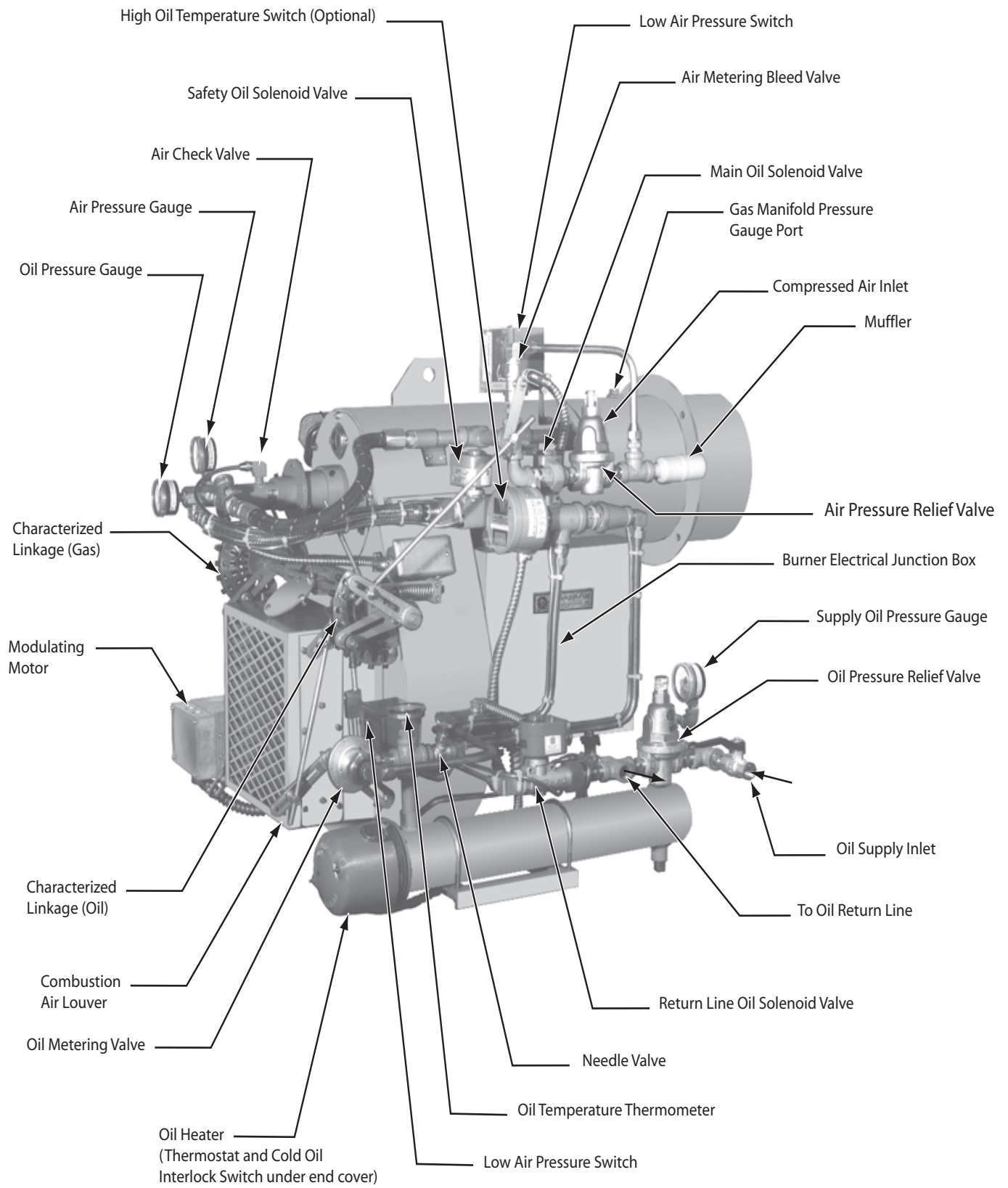

TYPICAL MODEL F WITH HEAVY OIL SYSTEM

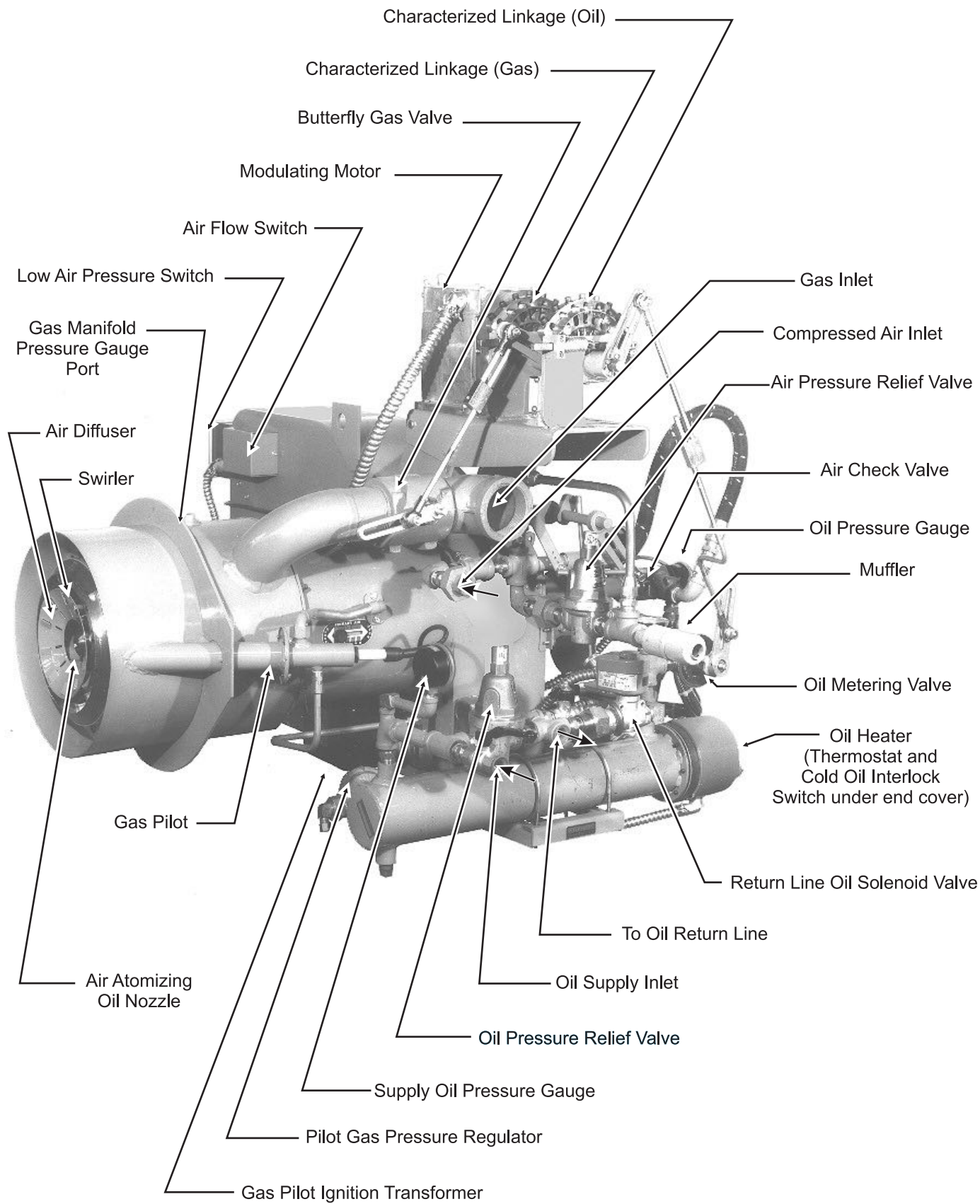

TYPICAL MODEL FL WITH HEAVY OIL SYSTEM

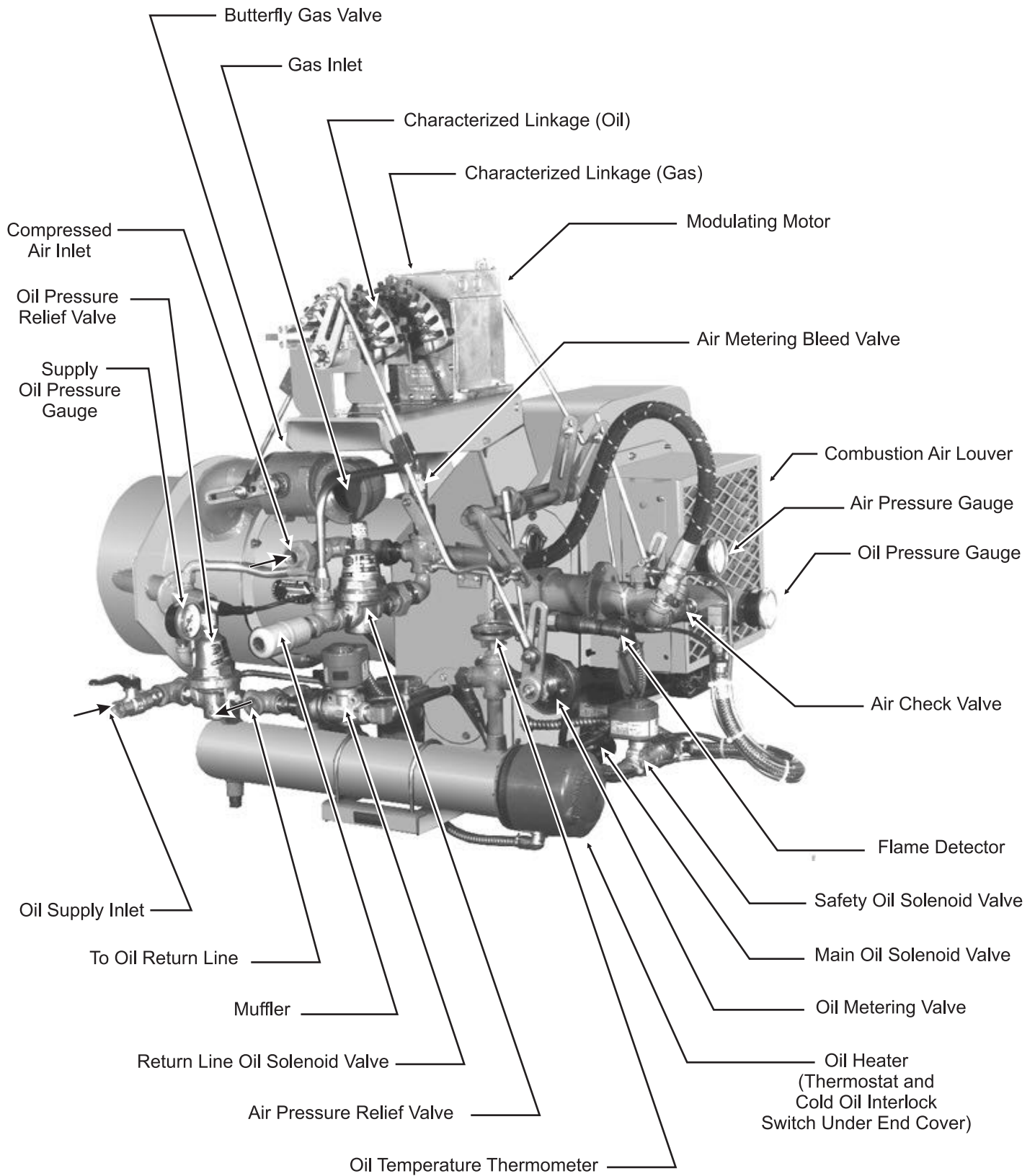

TYPICAL MODEL FL WITH HEAVY OIL SYSTEM

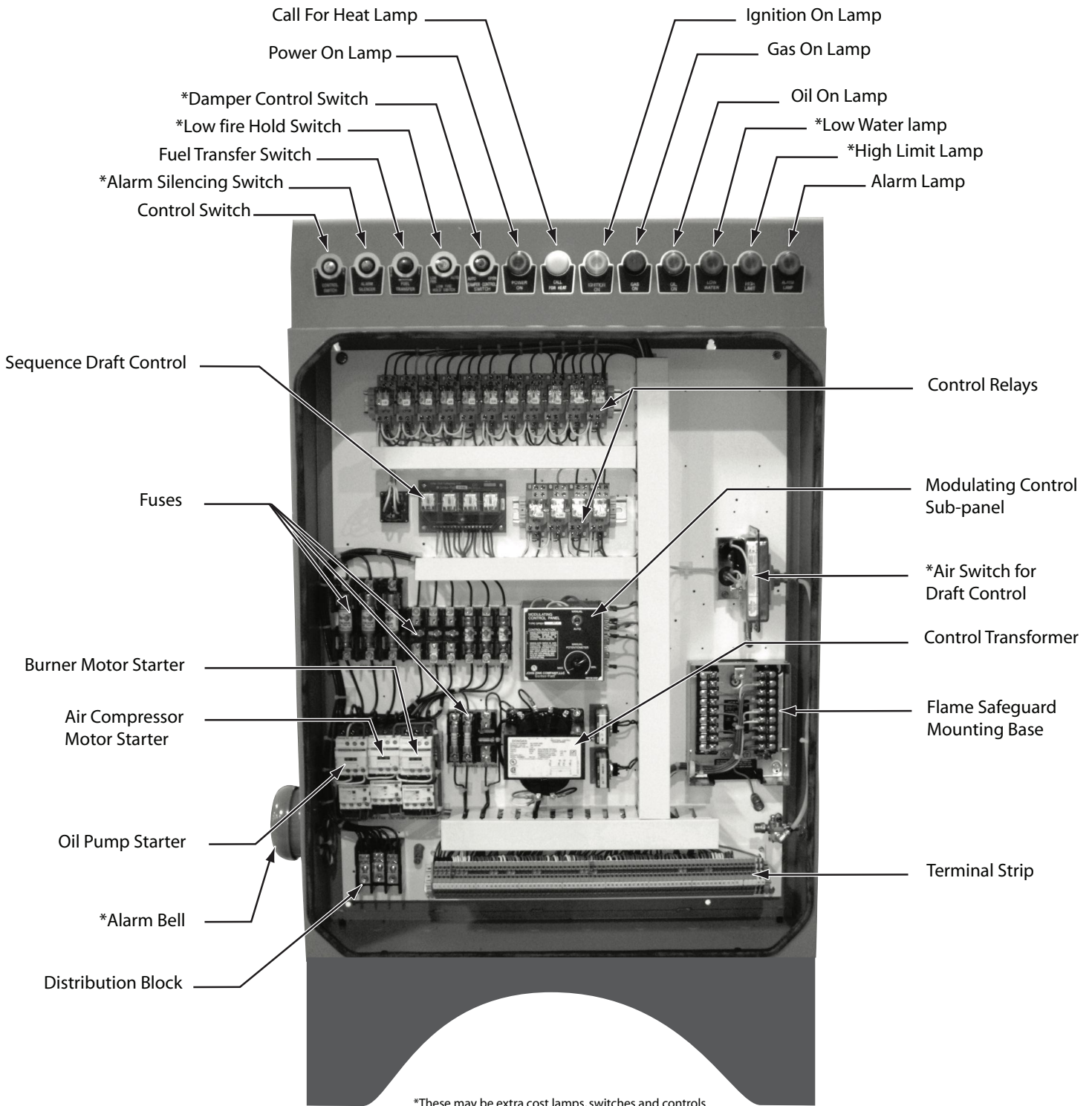

TYPICAL NO. 2 THROUGH NO .6 OIL SYSTEM CONTROL PANEL

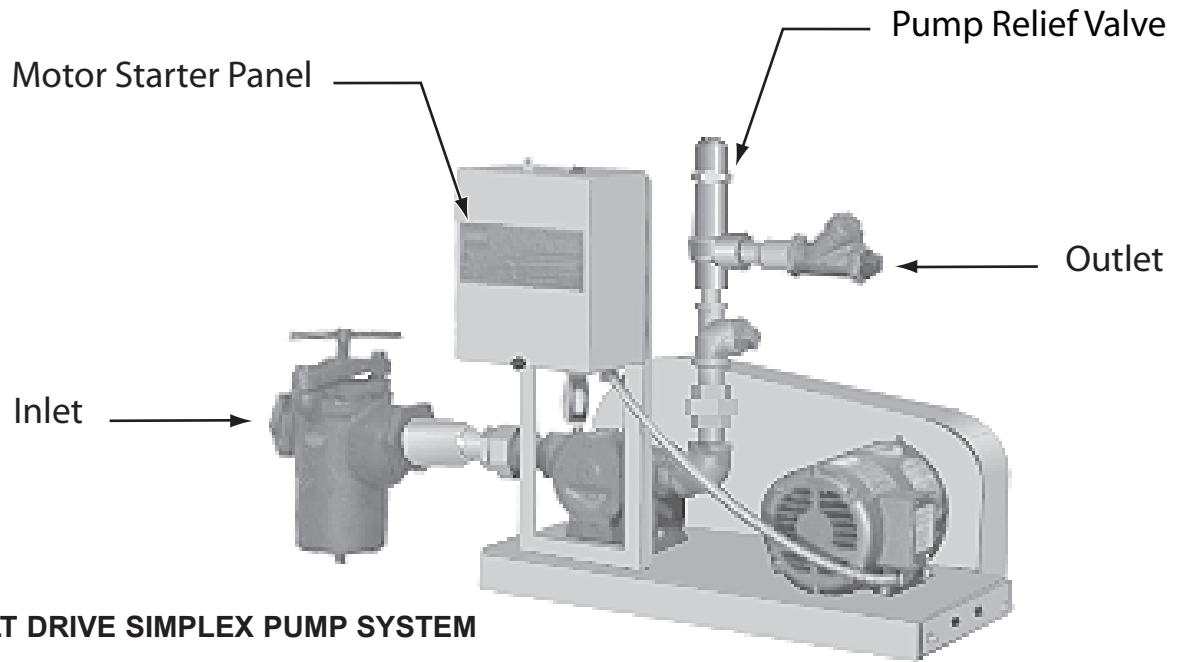

TYPICAL V-BELT DRIVE SIMPLEX PUMP SYSTEM

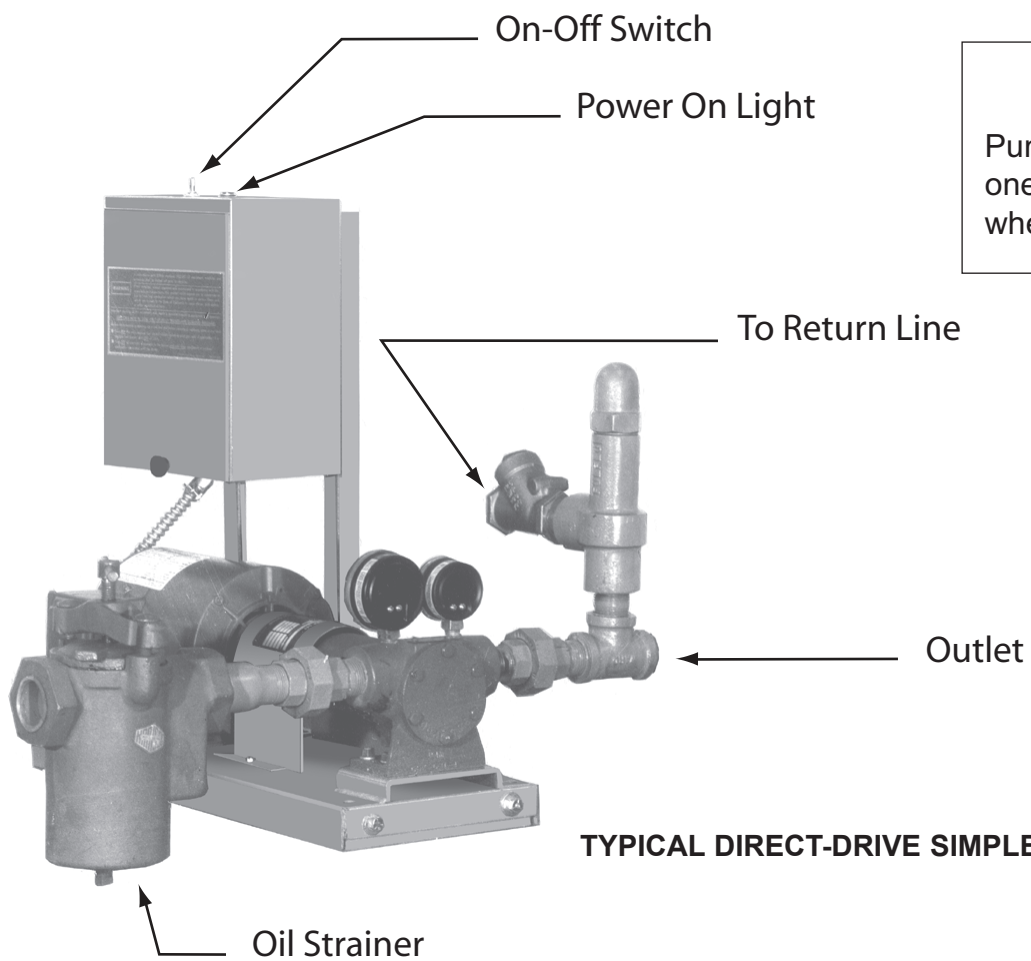

NOTE
Pumps may serve one or more burners when sized properly.

TYPICAL DIRECT-DRIVE SIMPLEX PUMP SYSTEM

OIL PUMP SETS WITH MOTOR STARTER PANEL

PART IV

SYSTEM DESCRIPTION

NOTE

Please read through these instructions and refer to the separate data sheets before attempting to start the burner. Do not attempt to start the burner until you have read and understood all information in this manual and supplements, if applicable.

1. **GENERAL** - The following data is pertinent to the burner start-up and should be carefully studied before any attempt to start the burner is made. This material is a part of the instructions manual which accompanies the burner.

- Burner Material List
- Burner Wiring Diagram and Operating Sequence
- Flame Safeguard Bulletin
- Gas System Schematic (If applicable) (See 1-F-40.3 for Gas Burners)
- Oil System Sheet (See 1-Gen-80.8 for No. 2 oil systems and 1-Gen-80.81 for No. 2 - 6 oil systems)
- Burner Identification and Numbering System (See 1-Gen-10.1)
- Miscellaneous Manufacturer's Data on Controls, Valves, Regulators, Etc.

NOTE

The above cited manual is "One of a Kind" in that it contains material covering your specific burner. To replace it, considerable time, special handling, and significant costs are involved. Accordingly, it should be handled with care and kept in a location free of dust and moisture.

WARNING

Do NOT use teflon tape as an oil or gas pipe sealant. Teflon tape can cause valves to fail creating a safety hazard. Warranties are nullified and liability rests solely with the installer when teflon tape is used. Use a pipe joint compound rather than teflon tape.

2. **GAS PIPING INFORMATION** - The gas piping size furnished and the minimum gas pressure required at the inlet to the piping is shown in the Order Entry Form contained in the manual shipped with the burner.

Gas piping should be sized to provide the required minimum pressure at the main manual shutoff when operating at maximum input. Consult your local utility on any questions regarding gas pressure, piping pressure drops allowable and local piping requirements.

Gas piping should be installed in accordance with the American National Standard, ANSI Z223.1 and any other local codes which may apply. All gas piping should be tested after installation with air pressure or inert gas for at least three times the gas pressure that will be used. The piping ahead of the main manual shutoff shall include a full size dirt pocket or trap.

E2 GAS SYSTEM

Modulating, Proven Low Fire Start

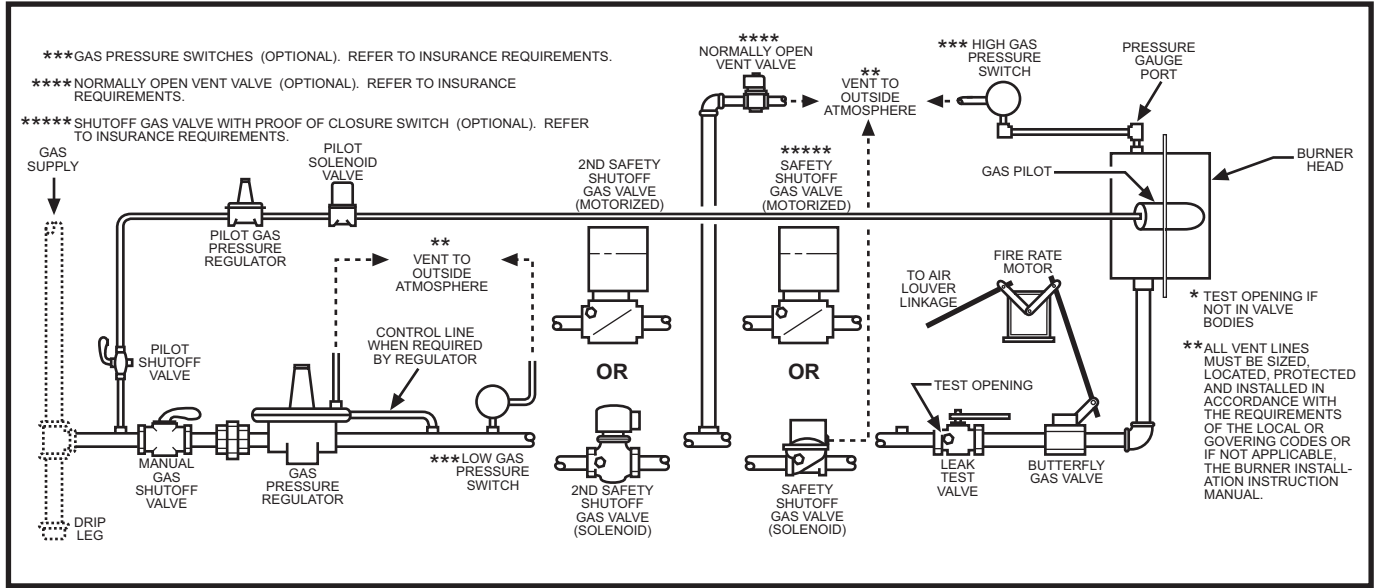

“E2” Gas System Schematic
(As shown meets U.L. requirements)

FIG. 4-1

APPLICATION

The "E2" gas system is used for modulation or high-low proven low fire start control in firing. It is commonly used on burners with 1,000 and MBh capacity and is used in conjunction with the "F6R", "F7", "F7T", "F8", "F8H", "F9" and "F9H" oil systems for combination gas-oil models.

DESCRIPTION

The "E2" gas system uses motorized gas valves or quick opening solenoid gas valves and a modulating motor to provide a low fire to high fire gas flow and simultaneously regulate the combustion air available to the burner. Gas pressure is adjusted and maintained by a pressure regulator. Head or orifice pressure is varied by a butterfly metering valve linked to the modulating motor. The gas butterfly metering valve is opened for high fire and gas is delivered to the orifices at the pressure setting of the pressure regulator. The air louver is also linked to the modulating motor, thus combustion air is increased proportionately as the orifice pressure increases.

OPERATING SEQUENCE

The burner motor starts on a call for heat by the operating control and the pre-purge cycle begins. At the end of pre-purge, the air louver must be in the closed (low fire) position for the low fire guarantee switch to close and allow ignition. Also, at the end of pre-purge, the ignition transformer is energized and the pilot valve

opens, igniting the gas pilot.

The flame detector proves the flame and the safety shutoff gas valves open, supplying gas to the orifices at the low fire setting of the butterfly metering valve and the burner ignites at the low fire rate.

The ignition transformer and pilot valve are de-energized.

After a short delay for main flame stabilization, the modulating motor is switched to the control of a potentiometer or high-low controller, which drives the motor from the low fire position toward the high fire position to match the boiler load. Since both the air inlet louver and butterfly metering valve are linked to the modulating motor, the combustion air is increased proportionately as gas increases.

As the boiler load is reached, the potentiometer or high-low controller drives the motor back toward the low fire position. On modulating units, the burner modulates over the range between low fire and high fire in response to the boiler load.

When the operating control is satisfied, the gas valves close and the burner motor is switched off, causing the burner to shut down and await the next call for heat.

3. **COMPRESSOR** - Piston type compressors are described in catalog sheet 6-10-2.51. The oil is contained in the crank-case and the proper level is shown on the dip stick or sight glass. Carefully follow the applicable manufacturer's instructions for care, maintenance and the proper lubricating oil.

4. **OIL SYSTEMS** - Refer to Figures 4-2 and 4-3 for basic piping diagrams. For detailed information, refer to the specific catalog sheets or drawings supplied with your burner.

CAUTION

One of the most common oversights by an installer is failure to purge air, water, rust or other foreign matter from the oil system. **DAMAGE TO PUMPS AND OTHER COMPONENTS CAUSED BY RUST, WATER OR FOREIGN PARTICLES IS NOT COVERED BY WARRANTY.**

A standard method for purging is to remove the system pressure gauge (or plug where gauge would normally be installed) and temporarily install a piece of copper tubing long enough to drain into a bucket or other container. The pump motor starter contacts are then manually depressed with a piece of wood or other non-conductor device and the pump allowed to run until purging is complete. There must be no sign of air, water, rust or other foreign matter in the flow.

If flow is not established within 2 minutes, the pump should be primed through the suction line. Reinstall gauge or plug after purging is complete.

5. **LIGHT OIL** - Back off the back pressure regulating valve and oil pump relief valve to allow circulation at a few pounds pressure with all oil being returned to the tank. Run this way until entrained air is expelled then slowly build up the oil pressure in the circulating loop to 100 PSIG by tightening up the springs in these same valves.

NOTE

The oil pump relief valve should be set to start opening at 5 to 10# above the setting of the back pressure regulating valve.

6. **HEAVY OIL** -

For Heavy No. 5 and 6 oil, the supply temperature must be maintained by a separate oil circulating and heating system which returns the hot oil to the tank and maintains the oil at a pumpable temperature.

NOTE

The heavier oils require a separate oil tank heating system.

Operate the oil pump system as outlined for light oil except the pump must run continuously even when the burner is not in operation. This is necessary to maintain circulation of hot oil through the burner's oil valve system. Set loop circulating oil pressure at 80 to 100 PSIG.

AIR ATOMIZING No. 2 Oil

F8 OIL SYSTEM

MODULATING OR HIGH-LOW PROVEN LOW FIRE START CONTROL

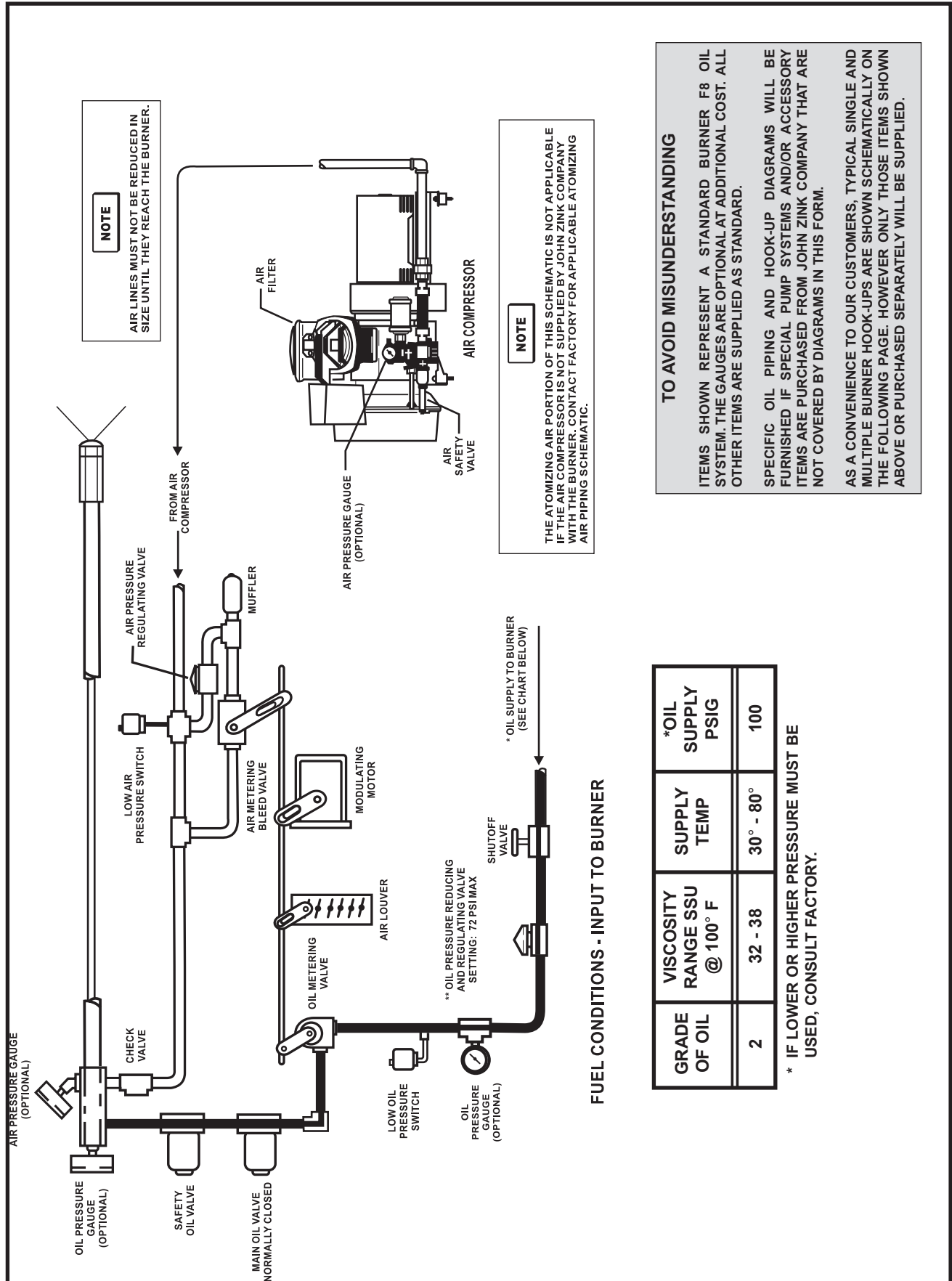

Figure 4-2 TYPICAL NO. 2 OIL SYSTEM SCHEMATIC (Shown in Firing Position)

AIR ATOMIZING No. 2-6 Oil

F8H OIL SYSTEM

MODULATING OR HIGH-LOW PROVEN LOW FIRE START CONTROL

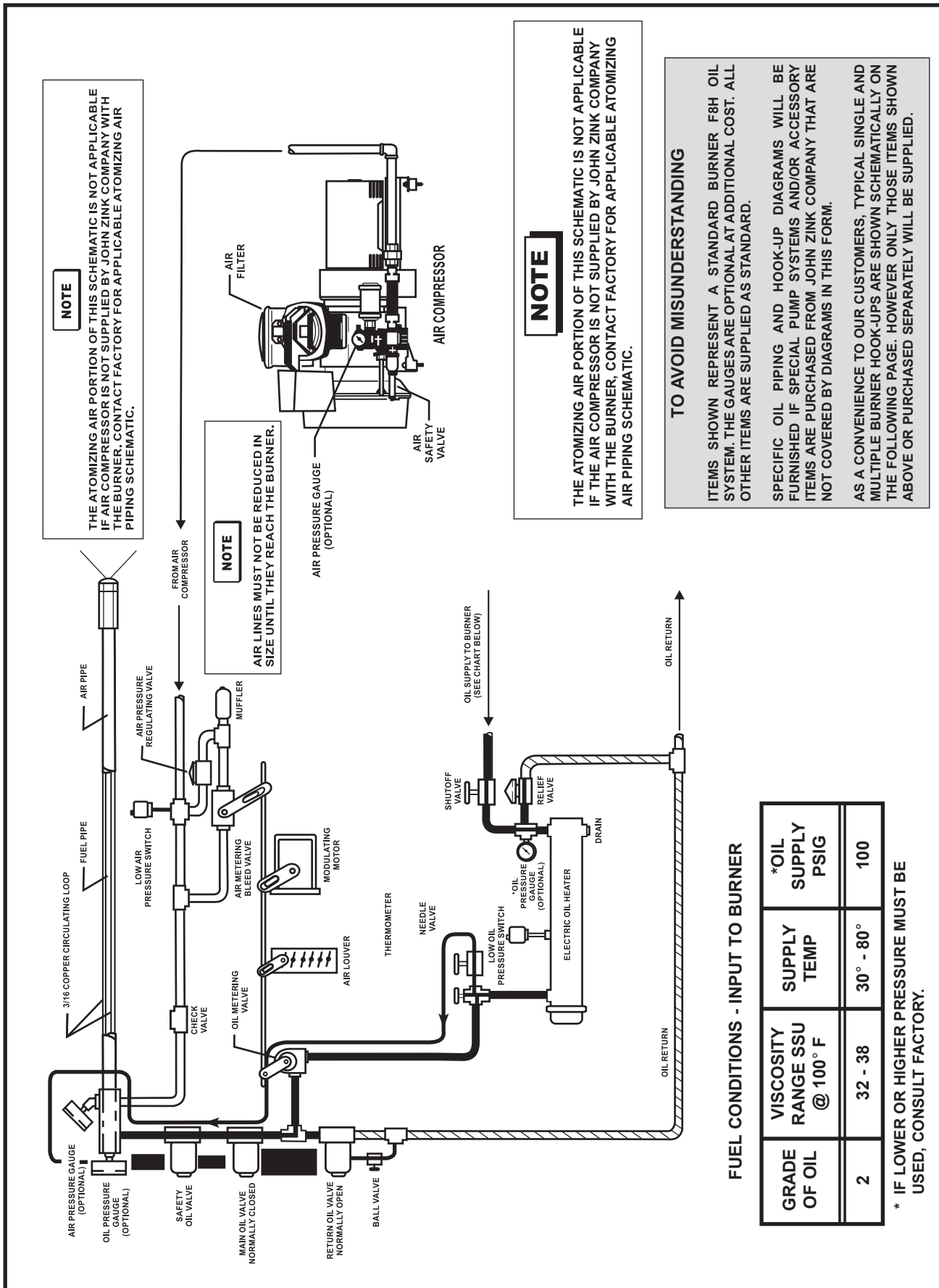

Figure 4-3 TYPICAL NO. 2-6 OIL SYSTEM SCHEMATIC (Shown in Firing Position)

7. **OIL-HEATING** - Before any attempt is made to start the burner, the main oil heating system must be adjusted to deliver the proper supply temperature to the burner electric heater. The thermostat on the burner or trim electric heater must now be adjusted to deliver hot oil at the specified nozzle firing temperature at follows:

GRADE OF OIL	VISCOSITY RANGE SSU @ 100 Deg. F	NOZZLE FIRING TEMPERATURE Temp. at Therm. On Heater
4	45 - 125	100 ^o - 140 ^o
Light 5	150 - 300	125 ^o - 160 ^o
Heavy 5	350 - 750	160 ^o - 200 ^o
6	900 - 9000	200 ^o - 230 ^o

The burner trim electric heater thermostat adjustment is described briefly in ITEM 8 of SECTION V. Complete instructions may be found in the manufacturer's data sheet or on the thermostat instructions plate.

8. **AIR PRESSURE CONTROL AND REGULATION** - The rotary air compressors have a safety relief valve set and sealed at 32 PSIG while the piston type compressors have a relief valve set and sealed at 55 PSIG.

The rotary air compressor safety relief valve discharges back into the intake since the released air contains oil vapor. When piston type compressors are used, the safety relief valve will vent to atmosphere since the released air is relatively oil free.

Nozzle air pressure is controlled by a bleed-off type air metering valve, ITEM 9, and an air pressure regulating valve, ITEM 10 of SECTION V.

The bleed-off valve is operated by linkage from the modulating control and both valves bleed excess air to the compressor air intake as the burner modulates to lower firing rates.

The air pressure regulating valve can be used to unload excessive air volume at high fire.

CAUTION

Care should be taken in order to prevent overheating the oil which could cause the formation of carbon in the heater and clogging of the nozzle line strainer. Also, overheating causes gassing of oil resulting in flame pulsation and loss of retention on the burner head.

Servicing must be done only by fully trained and qualified personnel.

CAUTION

If the oil is not hot enough, the quality of atomization will be reduced, causing carbon deposits on the burner diffuser, inner cylinder and boiler heating surfaces.

Servicing must be done only by fully trained and qualified personnel.

PART V

PRELIMINARY ADJUSTMENTS

1. **FACTORY ADJUSTMENTS** - The burner is adjusted at the factory to meet “dry run” conditions. Adjustments and initial settings must be checked prior to initial light-off and settings must be verified by combustion tests.

Depending on the model and capacity of the burner, various adjustment mechanisms control the air and fuel available for combustion, while others control the safe and reliable function of the gas-electric ignitor.

2. **ADJUSTMENT MECHANISMS** - Illustrations which follow show the items which are subject to adjustment. Determine the applicability of each illustration to your burner, then proceed to familiarize yourself with the function of the item. Where a setting is indicated, verify the setting or make preliminary adjustments as necessary to facilitate initial start-up.

NOTE

Adjustable air and fuel control mechanisms which modulate with the burner firing rate must be adjusted with the 0 to 90° actuator in the 0° position.

BURNER AIR AND FUEL ADJUSTMENTS

ITEMS 1 THROUGH 13

ITEM 1 ADJUSTMENT OF OIL DRAWER ASSEMBLY

DESCRIPTION

Oil burners have an assembly made up of vital oil and air handling components known as the “Oil Drawer Assembly.” Basically, this assembly contains the oil and air tubes, air vanes, the atomizing nozzle, the air diffuser with mounting bracket and an air/oil distributor block and back-plate which secures the unit to the burner housing.

HOW IT WORKS

LIGHT No. 2 OIL - See Figures 5-1 and 5-1A. The oil and air are delivered to the nozzle through a tube-within-a-tube arrangement. The outer tube carries the air while the inner tube carries the oil.

Oil and air pressures are indicated by gauges located in the air/oil distributor block.

The air and oil enter the mixing chamber of the nozzle, then the atomized oil is forced out the nozzle into the stream of combustion air. The air diffuser distributes the combustion air through the atomized oil which is then ignited by the gas pilot ignitor.

HEAVY No. 4, 5, 6 OIL - See Figures 5-1 and 5-1A. Heavy fuel oil requires heating to allow for pumping and proper atomization of the oil; therefore, the oil needs to be heated right up to the nozzle to insure clean, safe starts.

Heated oil from the burner oil heater is circulated around the oil supply tube thus maintaining a ready to fire temperature at all times. For start-up open circulating oil needle valve fully. After about 2-3 hours, drawer assembly will be hot. Valve should now be closed and re-opened approximately 1 to 2 turns. Valve is located on 1/2” cross above oil trim heater.

NOTE

If a No. 2 through No. 6 oil burner is being fired on No. 2 oil, circulating valve must be closed.

Once the oil is properly heated, the functional characteristics for both light and heavy oil systems are much the same.

OIL DRAWER ASSEMBLY WITHOUT QUICK DRAW OIL GUN FEATURE (Typical)

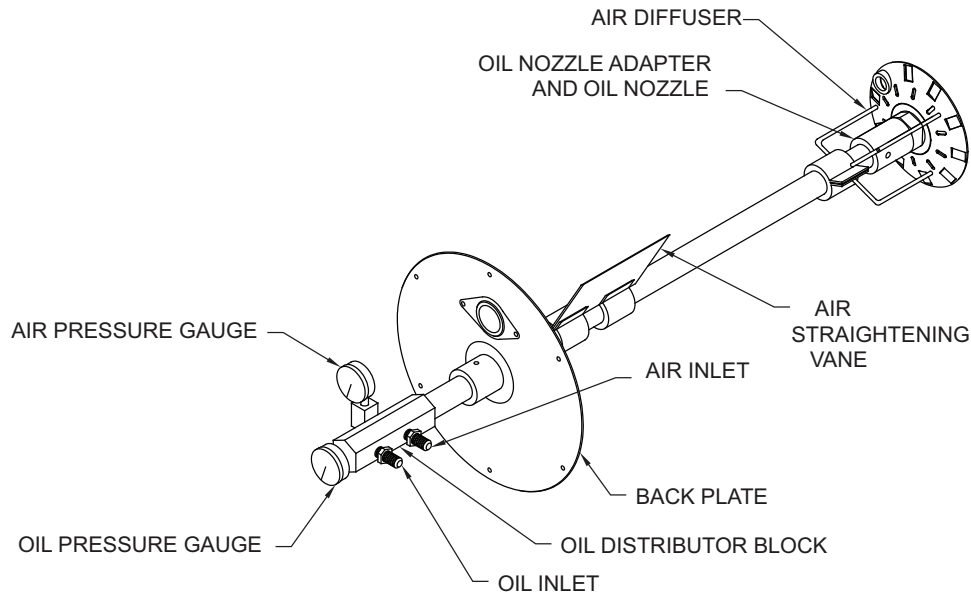

NO. 2 UNHEATED OIL DRAWER ASSEMBLY

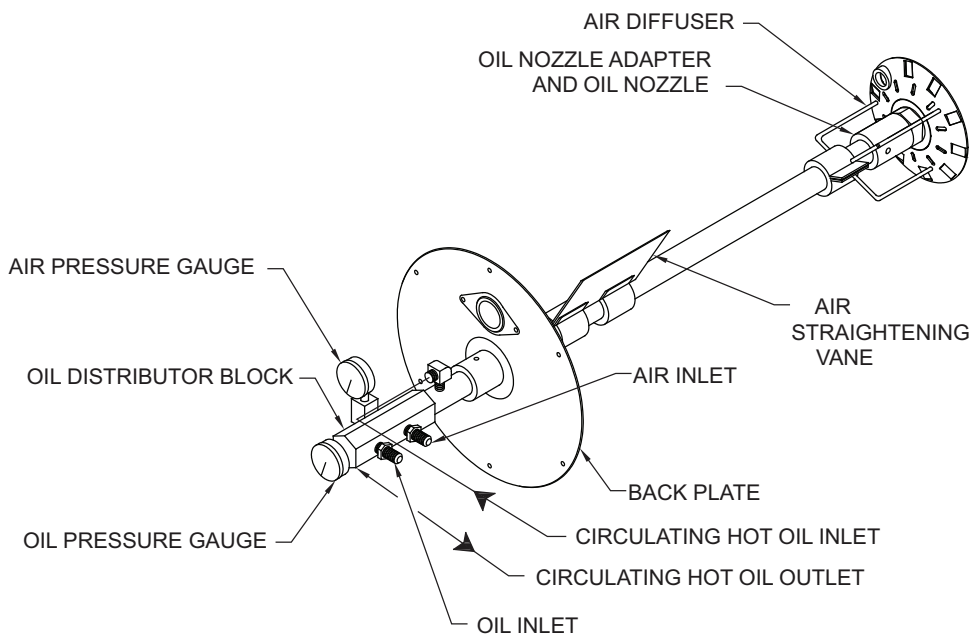

NO. 4, 5 & 6 HEATED OIL DRAWER ASSEMBLY

ADJUSTMENT PROCEDURE

NOTE

Adjusting the relationship between air diffuser and oil nozzle requires removal of the oil drawer from the burner.

The relationship between the air diffuser - oil nozzle and the inner fire cylinder may be adjusted in the following manner.

1. At back of burner, use Allen wrench to loosen set screw(s) in collar through which oil pipe protrudes.
2. Grasp oil distributor block and move oil drawer assembly in or out to obtain desired position, then re-tighten set screw(s) loosened in Step 1 above.
3. For initial start-up:

NOTE

Adjustment requirements cannot be finally established until after the burner is fired. The dimensions shown in Figure 5-1A will normally prove acceptable for start-up.

Figure 5-1 Adjustment of Oil Drawer Assembly

OIL DRAWER ASSEMBLY WITH QUICK DRAW OIL GUN FEATURE (Typical)

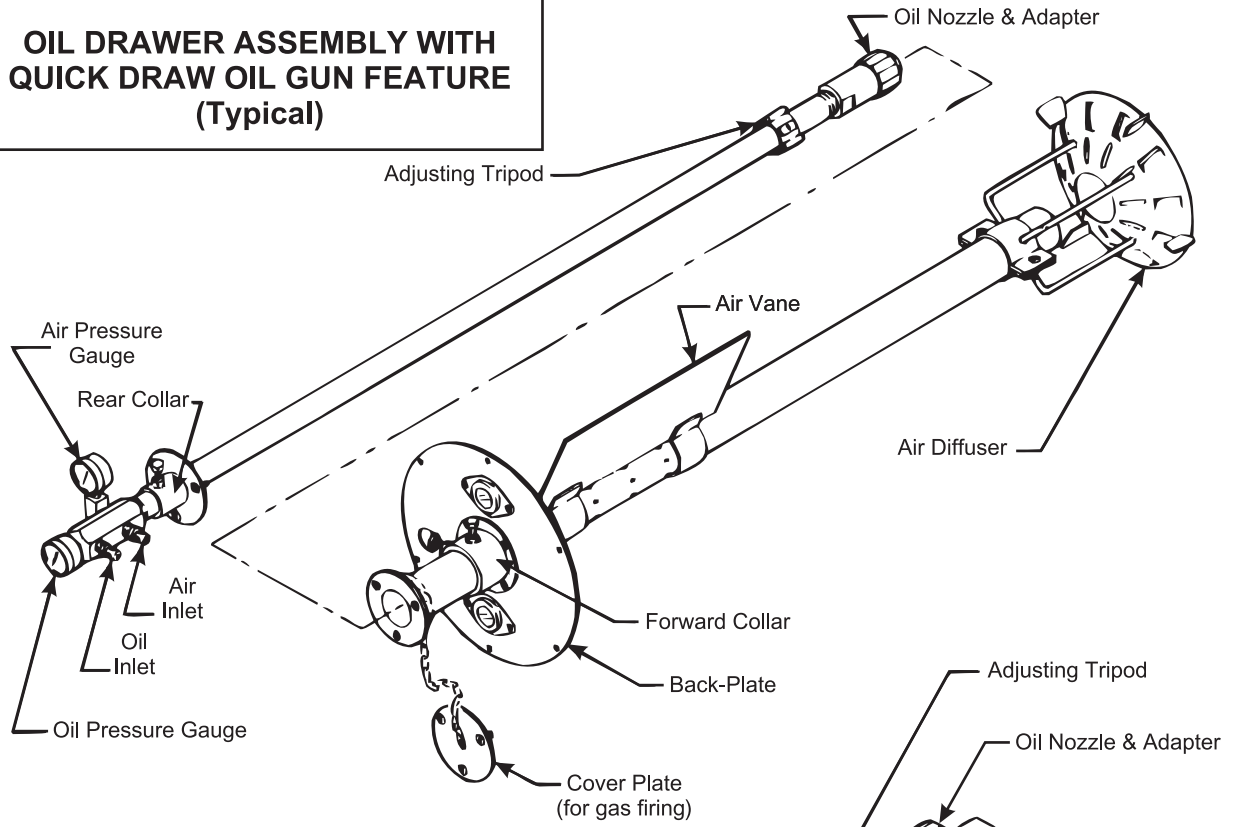

NO. 2 UNHEATED OIL DRAWER ASSEMBLY

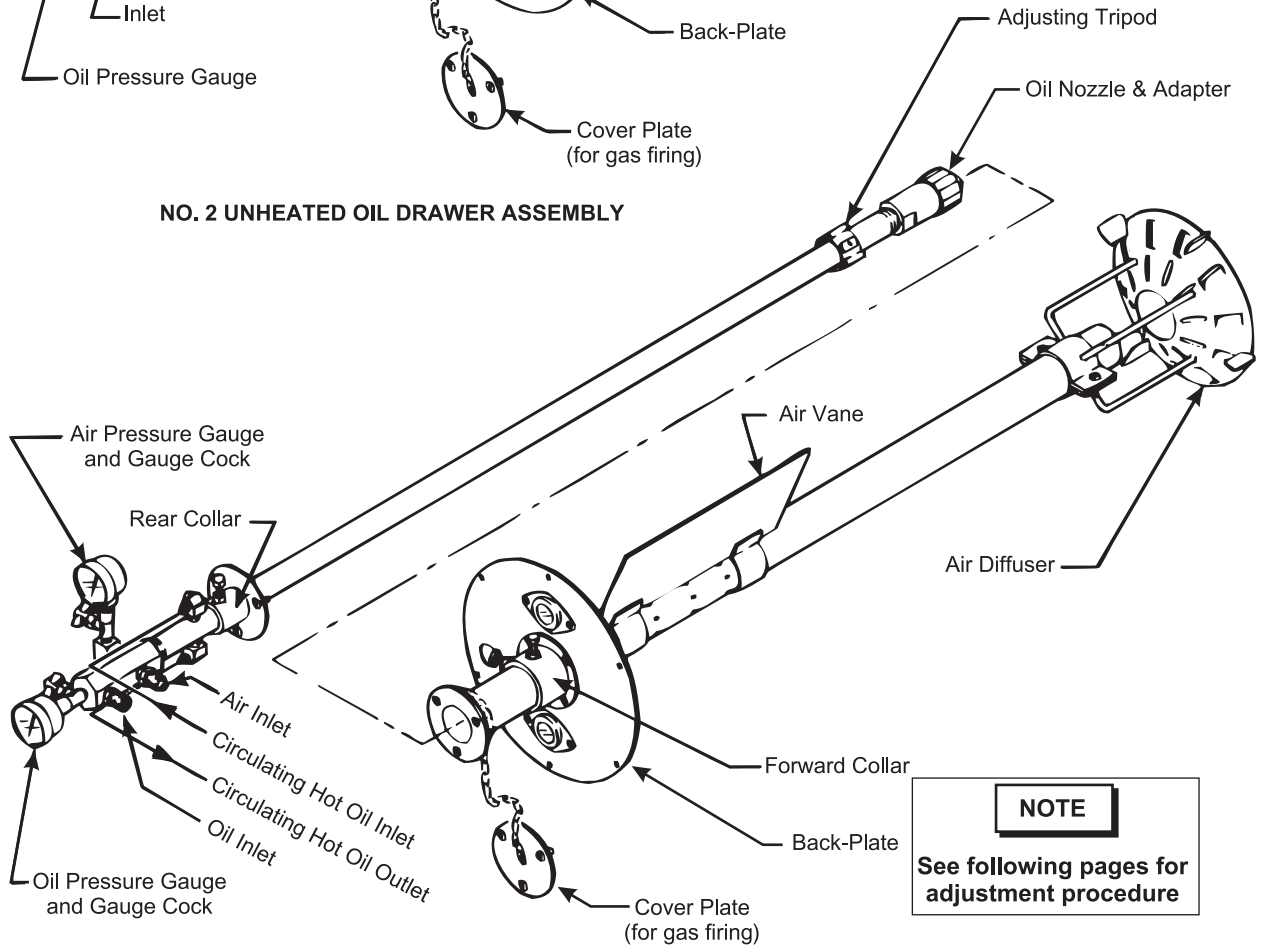

NO. 4, 5 & 6 HEATED OIL DRAWER ASSEMBLY

NOTE
See following pages for adjustment procedure

Figure 5-1 Adjustment of Oil Drawer Assembly

BURNER MODEL		OIL SYSTEM		BLOWER WHEEL SPEED & BOILER TYPE		OIL DRAWER ASSEMBLY ADJUSTMENTS		
F	FL	F8	F8H	3450 RPM		OIL NOZZLE	ILLST'N NO.	DIMENSIONS (Inches)
						(A)	(B)	(B)
X	X	X	X			Monarch	I	1/8 1/4
X	X	X	X			Monarch	II	1/4 1-1/2
X	X	X	X			JZ	III	3/8 1/4
X	X	X	X			JZ	VI	1/8 1
X	X	X	X	X	Firebox	Monarch	I	1/8 1/4
X	X	X	X	X	Scotch	Monarch	II	1/4 1-1/2
X	X	X	X	X	Firebox	JZ	V	1/8 1/4
X	X	X	X	X	Scotch	JZ	VI	1/8 1-1/2
X	X	X	X	X		Monarch	I	Flush 1/4
X	X	X	X	X		JZ	III	5/8 1/4
X	X	X	X	X	Firebox	Monarch	I	1/8 1/4
X	X	X	X	X	Scotch	Monarch	II	1/8 1
X	X	X	X	X	Firebox	JZ	III	1/2 1/4
X	X	X	X	X	Scotch	JZ	IV	3/8 3/4

NOTE

The dimensions shown are based on 90 degree nozzle spray angle. Increasing the nozzle spray angle will require the nozzle to be positioned farther forward in relation to the air diffuser center hole, while a decrease in angle will permit it to be moved back.

For any given spray angle, nozzles operated on light oil may be positioned farther back in relation to the diffuser.

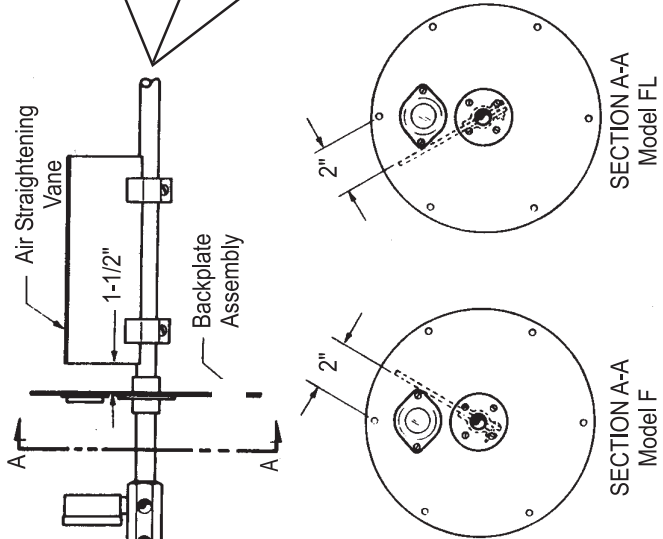
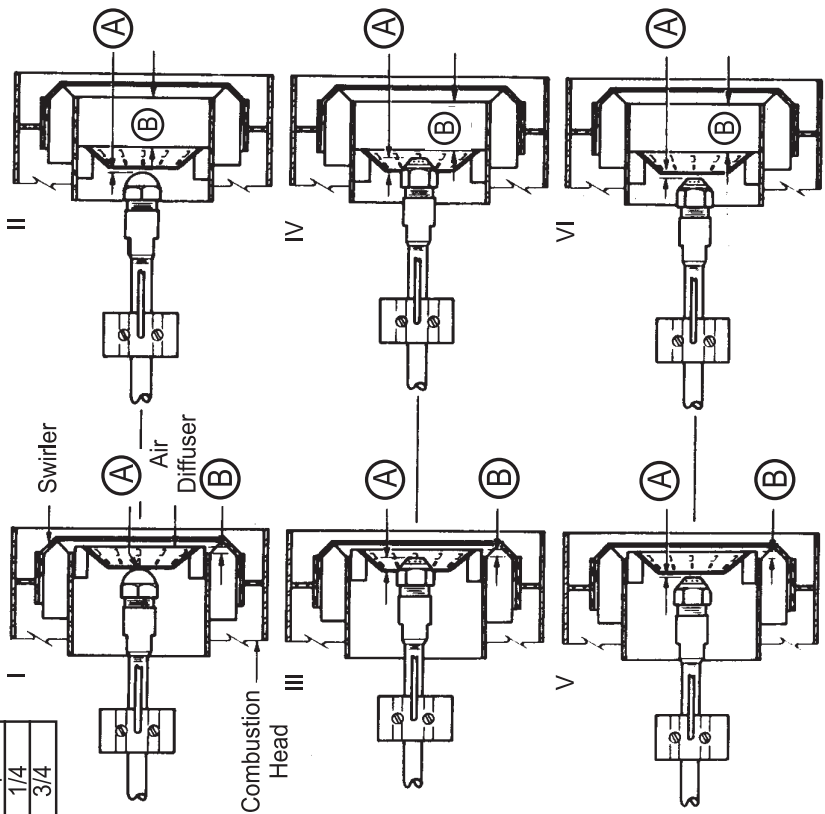

Figure 5-1A Adjustment of Oil Drawer Assembly

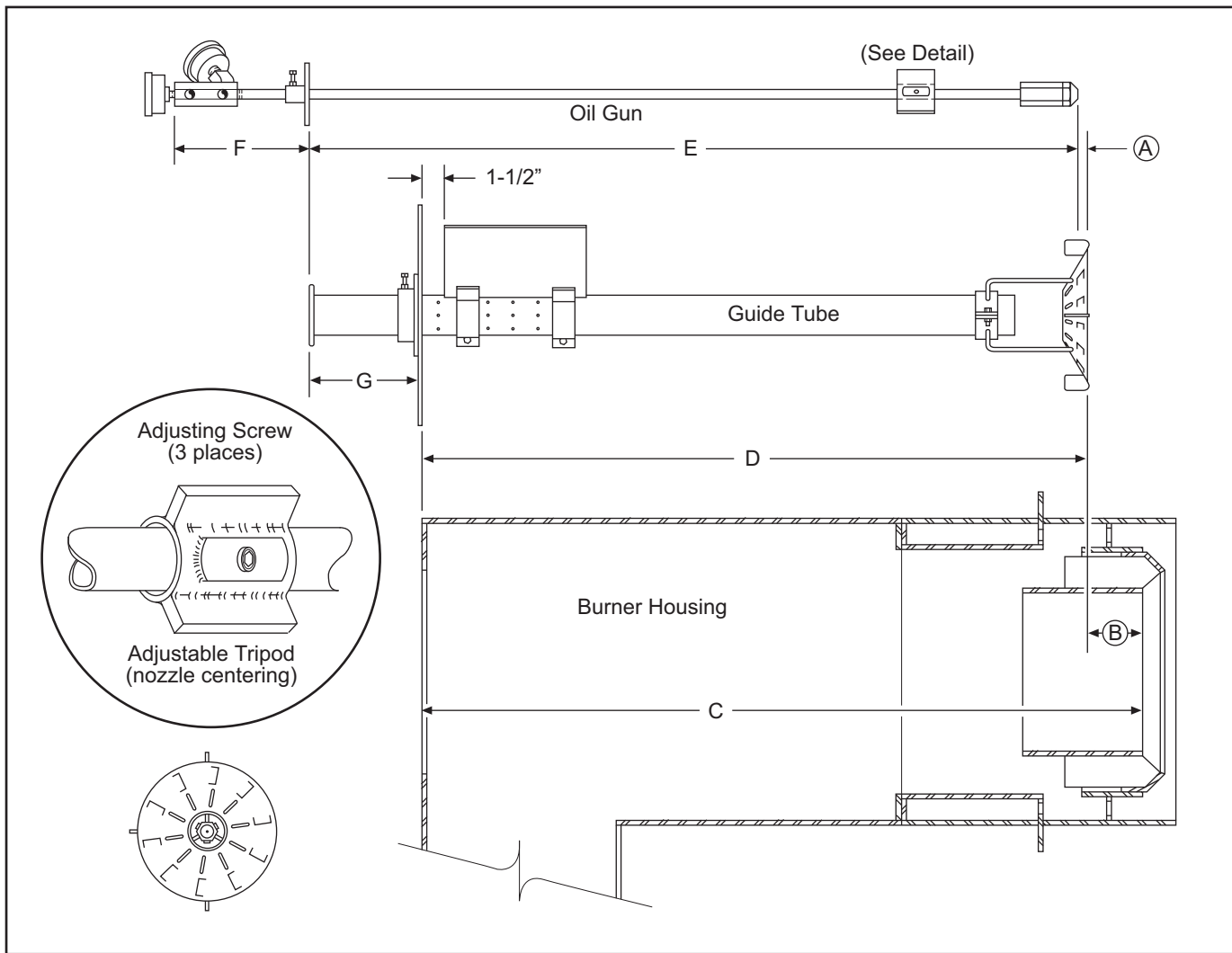

Figure 5-1B Dimensioning Detail for Oil Drawer Assembly with Quick Draw Oil Gun

ADJUSTMENT PROCEDURE

Oil Drawer Assembly with Quick Draw Oil Gun

Making accurate settings for the guide tube oil drawer assembly requires removal of the entire assembly from the burner housing.

REMOVAL: (See Figure 5-1)

WARNING

Do not remove while oil drawer is still HOT. This can result in serious burns or other injuries.

1. Tighten set screws in forward and rear collars to hold guide tube and oil gun securely in position.
2. Disengage couplings on atomizing air or steam, main oil and oil circulating loop lines.

NOTE

No. 2 (light) oil burners do not have the heated oil circulating loop.

3. Unscrew flame scanner and its adapter from end of sight tube.
4. Unscrew the nuts holding drawer assembly backplate to burner housing.

CAUTION

In the following step, do not permit front end of drawer assembly to fall as the diffuser slides out of swirler cylinder. Support rods, diffuser cone and diffuser spacers may be bent requiring repair or possible replacement.

5. Pull straight back on drawer assembly until back-plate clears the mounting studs.

Lower the rear end of the drawer slightly to provide sufficient clearance for the air vane to pass through the opening in the burner housing and slowly continue to pull the drawer back.

When an adequate gap exists between back-plate and burner housing, reach inside and support guide tube with the other hand. Drawer assembly may now be withdrawn fully.

ADJUSTMENT:

1. Set oil drawer assembly on a flat surface.
2. Using Figure 5-1A, determine the value of dimension **(A)**, then check for this dimension. If adjustment is necessary, loosen set screws in rear collar and slide oil gun in or out as required, then re-tighten set screws.
3. Determine the value of dimension **(B)**, then check for this dimension. If adjustment is necessary, refer to Figure 5-1B and measure to obtain dimensions C and D. The **(B)** dimension is the difference between dimensions C and D.

Loosen back-plate (forward) collar set screws and slide back-plate back or forward as required to obtain the correct value for dimension **(B)**; then re-tighten set screws.

Make certain the air vane is located properly in relation to the back-plate. (See Figure 5-1A). This can be changed by loosening the two clamp screws that secure the vane to the guide tube, re-positioning the vane, then

re-tightening the screws.

4. See Figure 5-1B. Check concentricity of air diffuser center hole with oil nozzle by measuring from nozzle body (or nozzle adapter) to inside of hole at three or four equidistant points.

If nozzle is off-center, check tightness of air diffuser clamp screws, and tighten is necessary.

If eccentricity persists, pull the oil gun from the guide tube as follows:

- a. Annotate the relationship of the oil nozzle to the center hole and the orientation of the couplings to the back-plate.
- b. Using a large flat bladed screw driver, rotate the three "quarter turn" fasteners on the oil gun flange 90° CCW to disengage them. The studs are held captive to the flange by washers.
- c. Carefully remove the oil gun straight out and place on a flat surface.

Note that the oil gun is centered in the guide tube by an adjustable tripod which is positioned and held in place by three screws.

Loosen and tighten the three adjusting screws as necessary to obtain the desired positioning, then check for nozzle concentricity by re-installing the oil gun in the guide tube; making sure the quick connect couplings are properly oriented with the back-plate. Repeat procedure until concentricity is obtained, then secure the oil gun with the three "quarter turn" fasteners.

5. Re-install the complete oil drawer assembly in the burner.

ITEM 2 ADJUSTMENT OF PRIMARY-SECONDARY AIR CYLINDER

DESCRIPTION - A separate air adjustment at the firing head provides a unique air control system enabling quiet, stable combustion without objectional noise or pulsation. This feature allows flexibility in adapting to a variety of job conditions and insures greater combustion efficiency.

HOW IT WORKS - See Figures 5-2 and 5-2A. Moving the position of the knobs forward reduces the amount of air available for combustion while movement to the rear increases the air supply. There are two versions of this mechanism.

1. Manually set and locked into position.
2. Automatic - Proportions the air at the firing head as the combustion control programs (modulates) the burner to meet the boiler load.

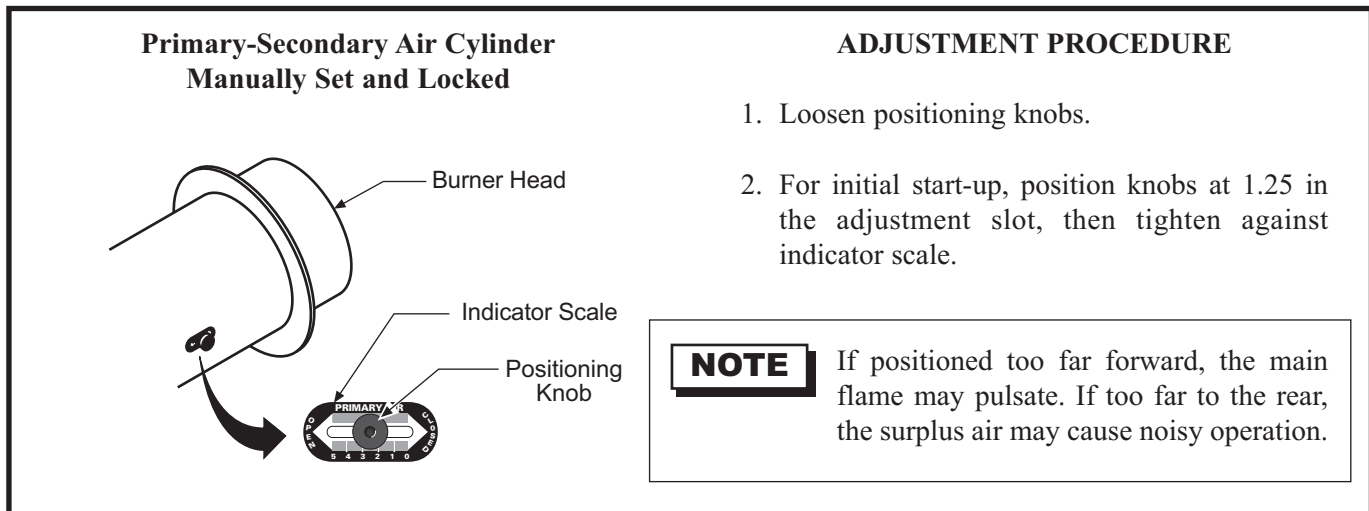

Figure 5-2 Adjustment of Manual Proportioning Primary-Secondary Air Control

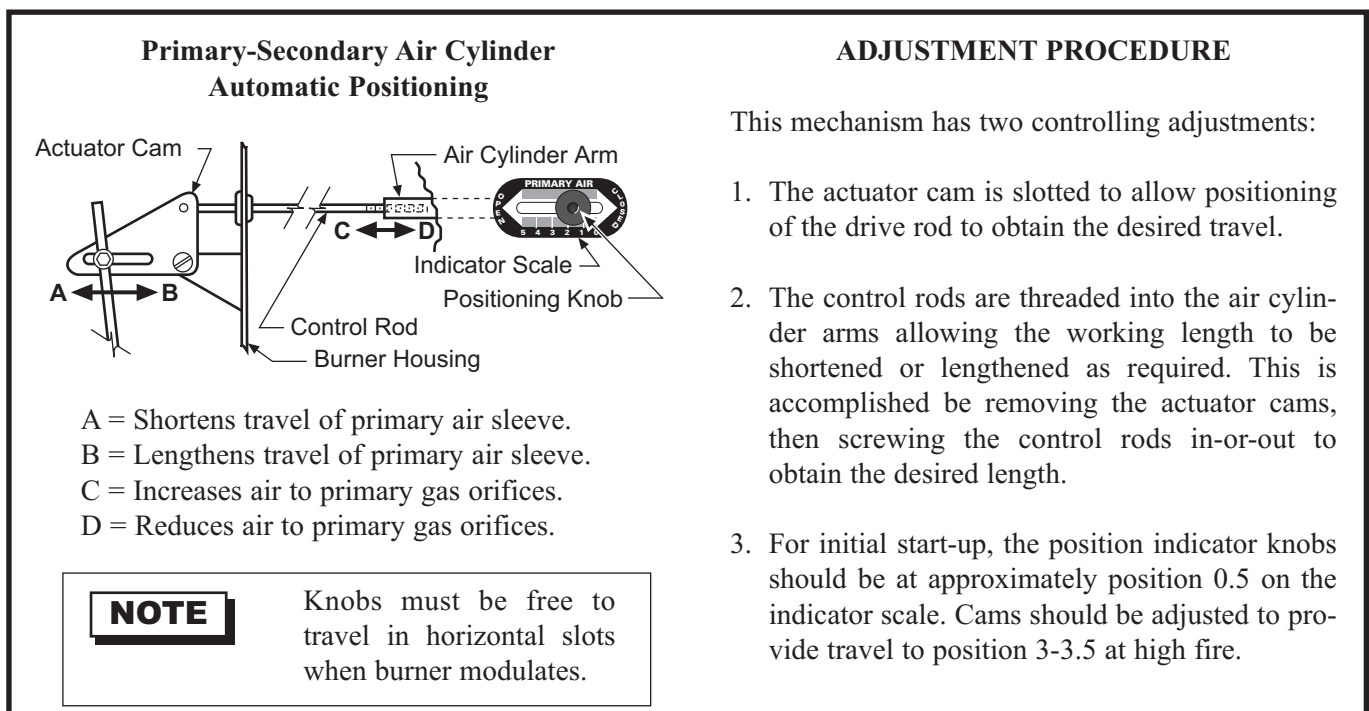

Figure 5-2A Adjustment of Automatic Proportioning Primary-Secondary Air Control

ITEM 3**ADJUSTMENT OF AIR INLET LOUVER BOX****DESCRIPTION**

The amount of air available for combustion is controlled by adjustable louvers located in the air box. The louvers are interconnected through a series of small linkage arms secured to a common drive rod.

HOW IT WORKS

See Figure 5-3. Louver opening and travel is controlled by adjusting the linkage mechanism from the actuator to obtain the desired opening and stroke. The actuator drives the louvers open or closed as the combustion control programs the burner firing rate to meet the boiler load.

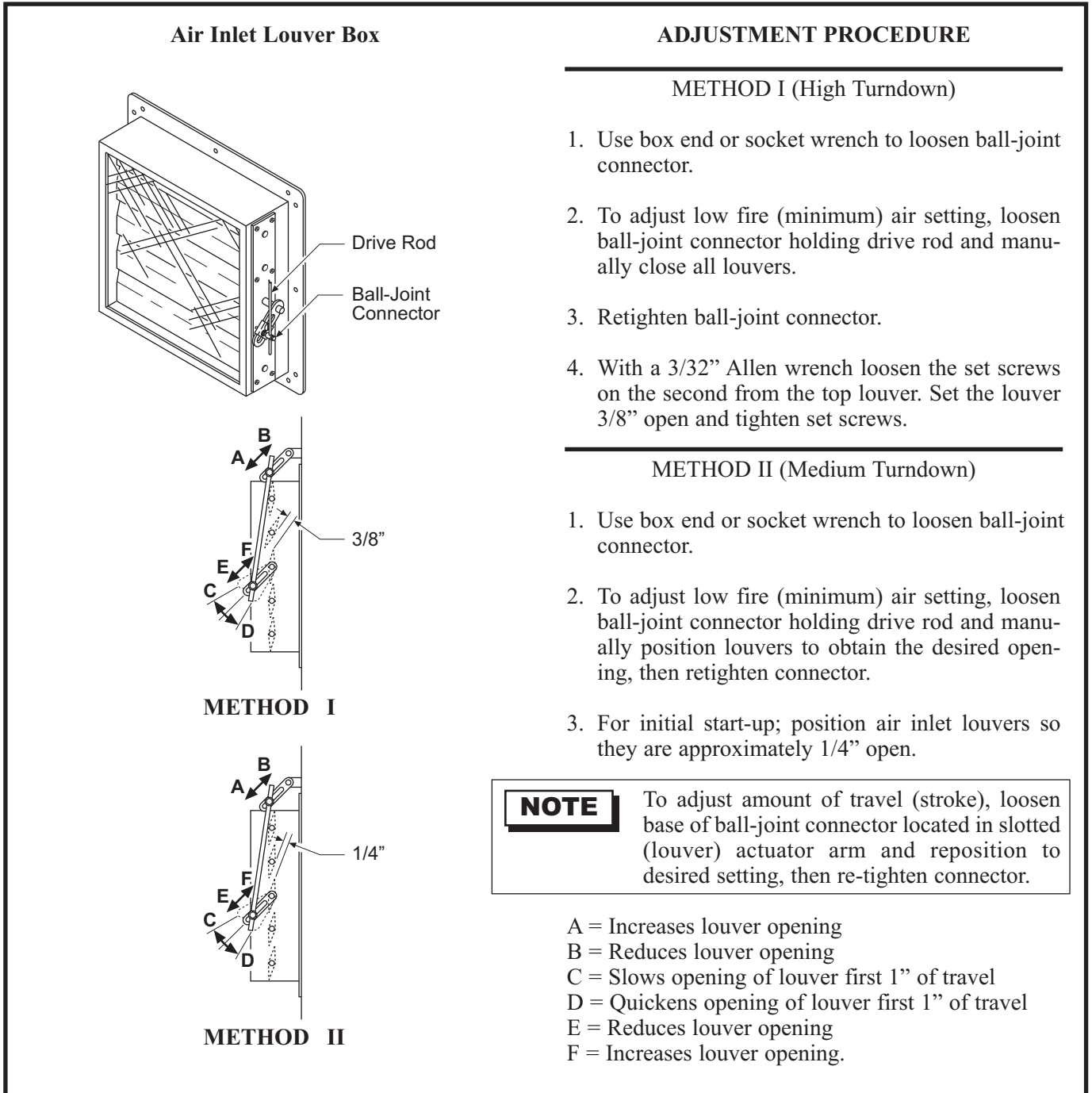

FIGURE 5-3 Adjustment of Air Inlet Louver Box

ITEM 4**ADJUSTMENT OF GAS PILOT IGNITOR ASSEMBLY****DESCRIPTION**

The gas pilot ignitor is basically composed of: (1) An ignition electrode with insulator which generates an arc between it and the adjacent ground, and (2) A fuel tube through which the gas is directed to the point of the electrical arc.

HOW IT WORKS

See Figures 5-4A and 5-4B. A charge from a high voltage transformer is routed to the ignition electrode causing an intense arc to ground. The electrode is then immersed in a concentration of gas as the pilot solenoid valve opens allowing flow to the pilot. The arc ignites the gas, the electrical discharge from the transformer terminates and the pilot stands ready to ignite the main burner flame.

ADJUSTMENT PROCEDURE**NOTE**

The gas pilot ignitor assembly is a vital part of the burner and must be kept clean and properly adjusted at all times.

WARNING!

To avoid risk of electricution, other injury or death, turn off all electrical disconnects to the burner and any other equipment or systems electrically interlocked with the burner. Turn off the manual pilot gas valve.

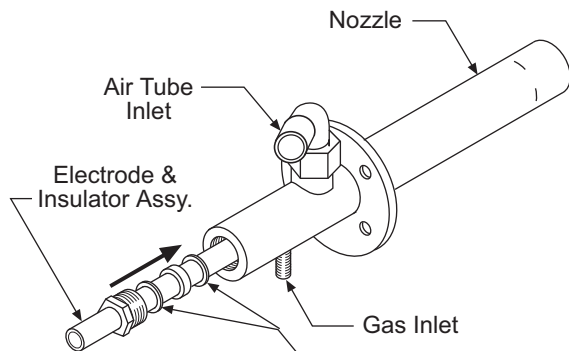
Gas Pilot Ignitor Assembly**NOTE**

Always install copper gasket with flat side to insulator.

NOTE

When viewing pilot flame, gas should be burning on full face of pilot insert.

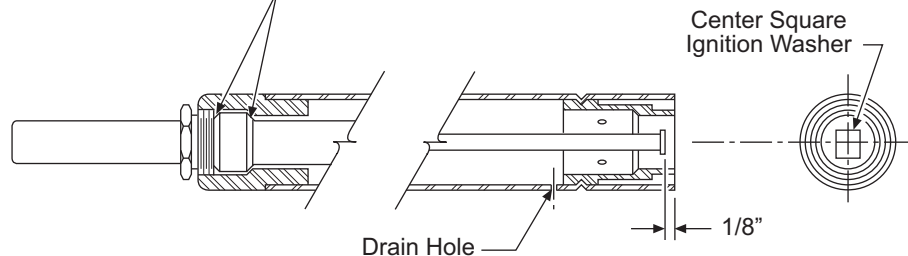

1. Disconnect cables, lines or tubes from the ignitor assembly and remove from burner housing.
2. Inspect square ignition washer for cleanliness and proper adjustment as shown.
3. Remove ignition electrode assembly and check insulator for cleanliness and/or cracks.
4. Burnish end of electrode tip and insert of pilot tube assembly with a battery terminal cleaner or similar device.
5. Reinstall ignition electrode assembly and check that square ignition washer is approximately centered in pilot assembly. If not, loosen electrode locking nut and rotate assembly and tighten nut.
6. Reinstall pilot assembly in burner.

FIGURE 5-4A Adjustment of Gas Pilot Ignitor Assembly

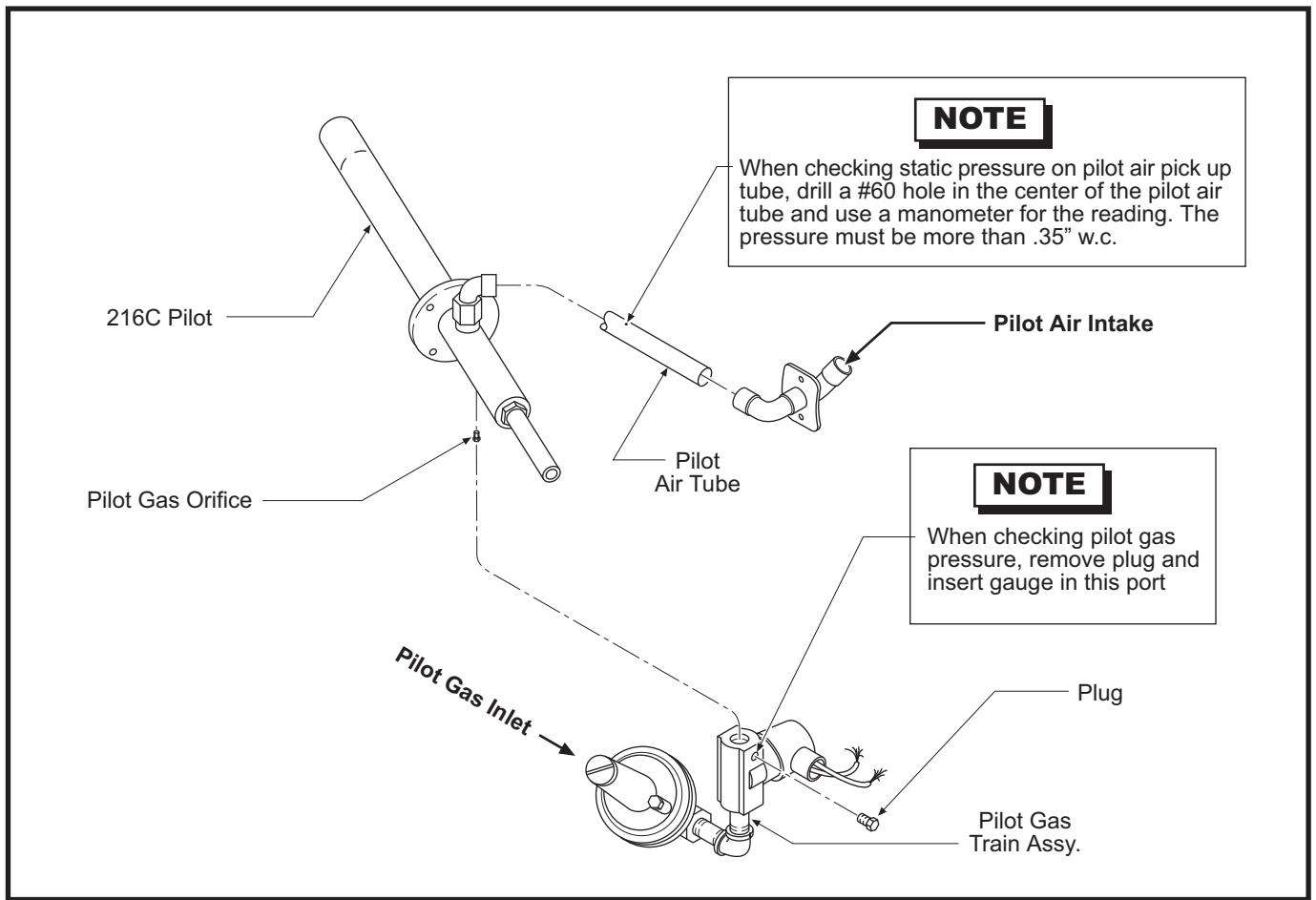

FIGURE 5-4B Adjustment of Gas Pilot Ignitor Assembly

PILOT TROUBLE SHOOTING

TROUBLE	PROBABLE CAUSE	ACTION
Motor runs but ignition spark does not occur.	Ignition cable or electrode loose or grounded.	Check to insure that ignition cable is securely plugged into electrode. Check cable and clean if necessary.
		Remove and check electrode insulator for cracks.
	Pilot ignition transformer defective.	Check for 120 volts on ignition transformer panel terminal. Replace transformer if required.
	Defective flame safeguard.	Check voltage on ignition terminal. Replace flame safeguard if required.
	Carbon hair on ignition electrode to ground.	Carefully remove pilot assembly and check for carbon hair. Remove, clean pilot assembly and ignition electrode, re-install and re-adjust pilot gas pressure for a leaner burning pilot.

PILOT TROUBLE SHOOTING

TROUBLE	PROBABLE CAUSE	ACTION
Motor runs, ignition occurs, but gas does not ignite.	No gas being supplied to pilot.	Check the manual pilot gas valve to insure that it is open.
		Make sure gas line has been purged of air.
		Pilot orifice plugged, clean.
		Gas pilot regulator locked up. Check inlet gas supply pressure. Replace gas pilot regulator.
	Pilot gas valve does not open.	Check for 120 volts to coil. Check valve action by sound and feel. Replace coil or valve body as needed.
Motor runs, gas pilot establishes, pilot flame does not prove.	Improper gas flow.	Increase or decrease gas pressure to pilot.
	Flame sensor dirty.	Clean or replace sensor.
	Flame sensor cannot see pilot.	Look down through sight tube. If unable to get clear view of pilot, correct problem.
	Improper ground circuit.	Check for voltage on natural wire to panel ground. Voltage must not be more than .5 volts.
	Pilot air supply incorrect.	Check static pressure on pilot air pick up tube. Must be more than .35" w. c. pressure. Open low fire air setting more.

ITEM 5 **ADJUSTMENT OF OIL METERING VALVE**

DESCRIPTION

Oil burners which have low fire start fuel control systems must deliver oil to the nozzle at reduced pressure and reduced oil flow for low fire. This is normally accomplished by throttling down the flow supplied to the nozzle.

HOW IT WORKS

See Figure 5-5. Most oil metering devices work on the principle of limiting flow by constricting the area through which the oil must pass. In order to vary the orifice area, mechanical movement must take place, thus the oil metering valve requires an actuator to do its job. Interconnecting a common actuator to the combustion air control and the oil metering valve allows the fuel (oil) to be proportioned in precise ratio to the amount of air available for combustion. This feature is essential on modulating type fuel control systems.

OIL METERING VALVE

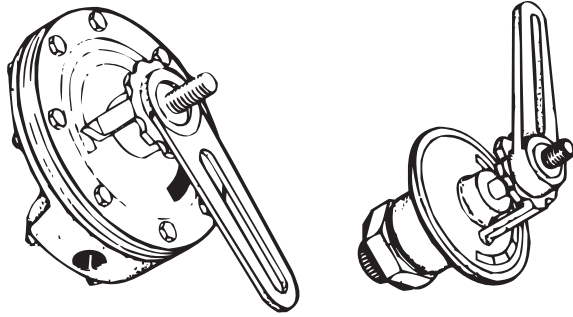

ADJUSTMENT PROCEDURE

NOTE

Valves vary by the amount of rotation required to cover the full range of regulation. Most valves will have a range from 0 to 90 or 0 to 120 . The maximum travel that can be realized from a 90 actuator and mechanical linkage arrangement is about 120 . The amount of travel to be used is dependent upon the required turn-down ratio (flow rates) between high-fire and low-fire and the flow characteristics of the particular valve.

For Initial Start-Up:

NOTE

Adjustment requirements cannot be finally established until after the burner is fired. The valve should work from a mostly closed position (1 to 2) when located in the supply line. This allows limited flow to the nozzle for low fire start.

NOTE

To adjust amount of travel, loosen base of ball-joint connector located in slotted actuator arm and reposition to desired setting, then re-tighten connector.

OIL METERING VALVE

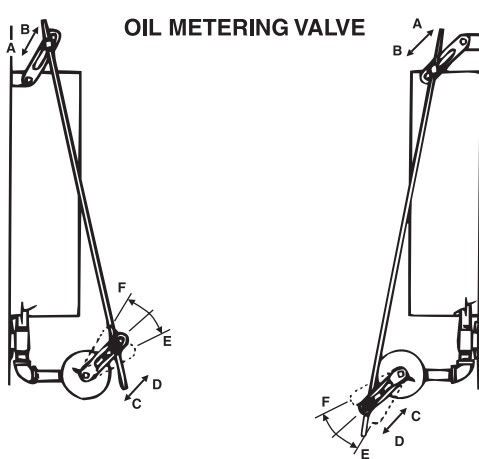

FL Burner

F Burner

TYPICAL F8 OIL SYSTEM

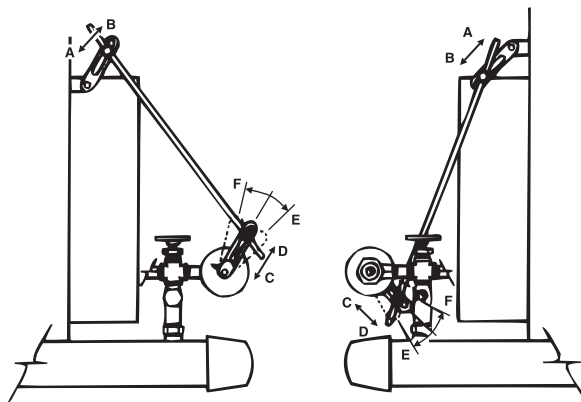

FL Burner

F Burner

TYPICAL F8H OIL SYSTEM

- A = Decrease travel of metering valve
- B = Increase travel of metering valve
- C = Increase travel of metering valve
- D = Decrease travel of metering valve
- E = Quickens travel first 1" of movement
- F = Slows travel first 1" of movement

FIGURE 5-5 Adjustment of Oil Metering Valve

ITEM 6**ADJUSTMENT OF LOW OIL PRESSURE SWITCH****DESCRIPTION**

Low oil pressure switches are often times used to insure the oil pressure at the nozzle is adequate for proper atomization of the oil.

HOW IT WORKS

See Figure 5-6. A pressure sensing device within the switch controls an electrical circuit normally interlocked with the flame safeguard causing the burner to recycle or shut down when the pressure sensed falls below the setting.

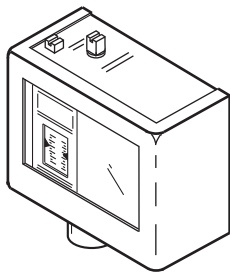
LOW OIL PRESSURE SWITCH

(Typical)

ADJUSTMENT PROCEDURE**NOTE**

See pressure switch manufacturer's instructions for detailed procedure.

1. From burner material list determine "Oil Pressure at Nozzle" (PSIG) requirement.
2. For initial start-up: adjust to a pressure well below the "Oil Pressure at Nozzle" (PSIG) shown to allow the burner to be set up.

NOTE

Final adjustment must be done after the burner has been test fired. See page 42, paragraph 4.11.

Figure 5-6 Adjustment of Low Oil Pressure Switch

ITEM 7A**ADJUSTMENT OF OIL RELIEF VALVE****DESCRIPTION**

A back pressure regulating valve is used to maintain a constant oil pressure in the system.

HOW IT WORKS

See Figure 5-7. The back pressure valve is the spring diaphragm type which automatically maintains a constant inlet or back pressure in the supply system by relieving any excess pressure.

ITEM 7B**ADJUSTMENT OF OIL PRESSURE REDUCING AND REGULATING VALVE (LIGHT OIL ONLY)****DESCRIPTION**

A pressure reducing and regulating valve is used to maintain a constant oil pressure in the system.

HOW IT WORKS

See Figure 5-7. The pressure regulating valve is the spring diaphragm type which automatically maintains a constant outlet pressure to the burner controls by means of a spring balanced diaphragm and orifice system.

OIL RELIEF VALVE

OIL PRESSURE REDUCING AND REGULATING VALVE

(Typical)



ADJUSTMENT PROCEDURE

1. Remove pressure adjusting screw cap.
2. Loosen locknut to free the adjusting screw.
3. Turn the pressure adjusting screw clockwise to increase pressure and counter clockwise to lessen pressure.
4. After the desired pressure is obtained, reset the locknut and replace the screw cap.

Figure 5-7A and B Adjustment of Oil Relief Valve and Pressure Reducing and Regulating Valve

ITEM 8

ADJUSTMENT OF BURNER OIL TRIM ELECTRIC HEATER

DESCRIPTION

For proper combustion of heavy oil, it must be delivered to the nozzle at a temperature that will insure thorough atomization. For this purpose a trim heater on the oil burner is used.

HOW IT WORKS

See Figure 5-8. The trim heater receives oil from the main oil heating system and maintains the oil at the specified nozzle firing temperature. The trim heater has a cold oil interlock switch which prevents the burner from starting until the oil is at a suitable temperature.

OIL TRIM ELECTRIC HEATER

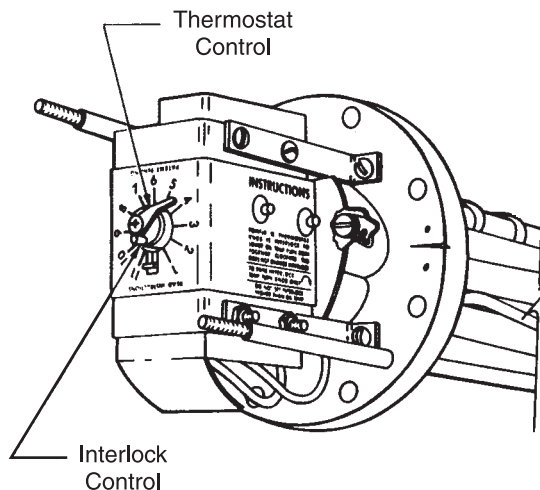

(Typical)

ADJUSTMENT PROCEDURE

1. Remove the bell cover which encloses the thermostat and interlock switch.

The pointer controls the thermostat setting while the knurled knob controls the interlock switch.

2. The thermostat pointer should be set at position 6 and then raised or lowered as required. Higher numbers call for higher temperatures.
3. The cold oil interlock switch is controlled by the small brass knurled knob under the pointer. This is set to prevent the burner from starting until a minimum oil temperature is attained and should be set 20-25 degrees below the oil temperature setting.

NOTE

Do not set the cold oil interlock higher than the oil temperature or burner will not start.

4. Replace bell cover.

Figure 5-8 Adjustment of Burner Oil Trim Electric Heater

ITEM 9**ADJUSTMENT OF BURNER AIR METERING BLEED VALVE****DESCRIPTION**

Air atomizing oil burners which have low fire start fuel control systems, must deliver reduced air pressure to the nozzle for low fire. This is normally accomplished by diverting a portion of the air delivery through a bypass return line back to the air compressor.

The amount of air pressure delivered to the nozzle versus the air returned to the air compressor is controlled by a device which limits or meters flow, thus an air metering valve is commonly used for this purpose.

HOW IT WORKS

See Figure 5-9. Most air metering devices work on the principle of limiting flow by constricting the area through which the air must pass. In order to vary the orifice area, mechanical movement must take place, thus the air metering valve requires an actuator to do its job. By interconnecting a common actuator to the combustion air control and the air metering valve, this allows the air pressure to be proportioned in precise ratio to the amount of oil flow and air available for combustion. This feature is essential on modulating type air pressure control systems.

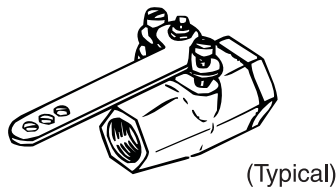
AIR METERING BLEED VALVE

(Typical)

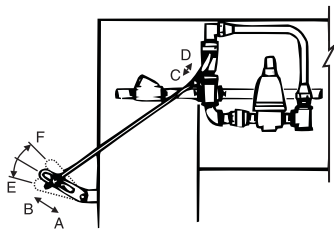

F Burner

TYPICAL F8 AND F8H AIR PRESSURE SYSTEM

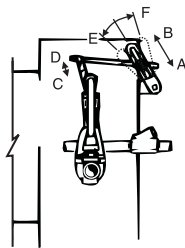

FL Burner

TYPICAL F8 AND F8H AIR PRESSURE SYSTEM

ADJUSTMENT PROCEDURE

At low fire the nozzle air pressure needs to be lower than at high fire. To accomplish this, the compressor air tees off at the burner and some of the air is bled off to atmosphere. As the burner modulates to high fire, the metering valve closes, forcing the air pressure at the nozzle to rise. At high fire the metering valve should be closed. See the material list for the approximate air pressure at high fire. Excess air pressure can be adjusted through the burner air pressure regulating valve (see Item 10).

NOTE

The shape of the pivoting stud (⊖) indicates the direction of the opening.

For initial start-up, use adjustment settings as received from the factory.

NOTE

Adjustment requirements cannot be finally established until after the burner is fired. Generally, the valve should work from a mostly open position when located in the bypass return line. Low fire pressures should be in the 10 to 15 PSIG range.

NOTE

To adjust amount of travel, loosen base of ball-joint connector located in slotted actuator arm and reposition to desired setting, then re-tighten connector.

- A = Decrease travel of metering valve
- B = Increase travel of metering valve
- C = Increase travel of metering valve
- D = Decrease travel of metering valve
- E = Slows travel first 1" of movement
- F = Quickens travel first 1" of movement

Figure 5-9 Adjustment of Air Metering Bleed Valve

ITEM 10**ADJUSTMENT OF BURNER AIR PRESSURE REGULATING VALVE****DESCRIPTION**

Back pressure valves are often times used to insure a constant air pressure to the system.

HOW IT WORKS

See Figure 5-10. Back pressure valves are of the spring diaphragm type and automatically maintain a constant inlet pressure or back pressure in the supply system by relieving excess pressure out of the system.

AIR PRESSURE REGULATING VALVE

(Typical)

**ADJUSTMENT PROCEDURE**

1. Remove pressure adjusting screw cap.
2. Loosen locknut to free the adjusting screw.
3. Turn the pressure adjusting screw clockwise to increase pressure and counter clockwise to lessen pressure.
4. After the desired pressure is obtained, reset the locknut and replace the screw cap.

Figure 5-10 Adjustment of Burner Air Pressure Regulating Valve

ITEM 11**ADJUSTMENT OF BURNER LOW AIR PRESSURE SWITCH****DESCRIPTION**

Low air pressure switches are often times used to insure the air pressure at the nozzle is adequate for proper atomization of the oil.

HOW IT WORKS

See Figure 5-11. A pressure sensing device within the switch controls an electrical circuit normally interlocked with the flame safeguard causing the burner to recycle or shut down when the pressure sensed falls below the setting.

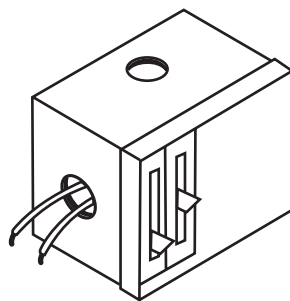
LOW AIR PRESSURE SWITCH

(Typical)

ADJUSTMENT PROCEDURE

NOTE See pressure switch manufacturer's instructions for detailed procedure.

1. From burner material list determine "Air Pressure at Nozzle" (PSIG) requirement.
2. For initial start-up: adjust to a pressure well below the "Air Pressure at Nozzle" (PSIG) shown to allow the burner to be set up.
3. Final adjustment must be done after the burner has been test fired. The lowair pressure switch should be set about 1# lower than the minimum air pressure registered at the nozzle during pre-purge.

Figure 5-11 Adjustment of Burner Low Air Pressure Switch

ITEM 12**ADJUSTMENT OF CHARACTERIZED LINKAGE****DESCRIPTION**

Characterized linkage provides the mechanical means to fine tune the fuel input (flow) to the burner in order to achieve maximum fuel efficiency and reduce stack emissions.

HOW IT WORKS

See Figure 5-12. There are nine (9) adjustment screws which control the contour of a flexible metal track upon which a roller and plunger mechanism travel. This mechanism in turn controls the linkage to the fuel valve, providing the precise amount of travel to dispense the right amount of fuel to the burner as it modulates to meet load demand. The objective is to shape the flexible metal track into amounts to a “combustion efficiency profile”.

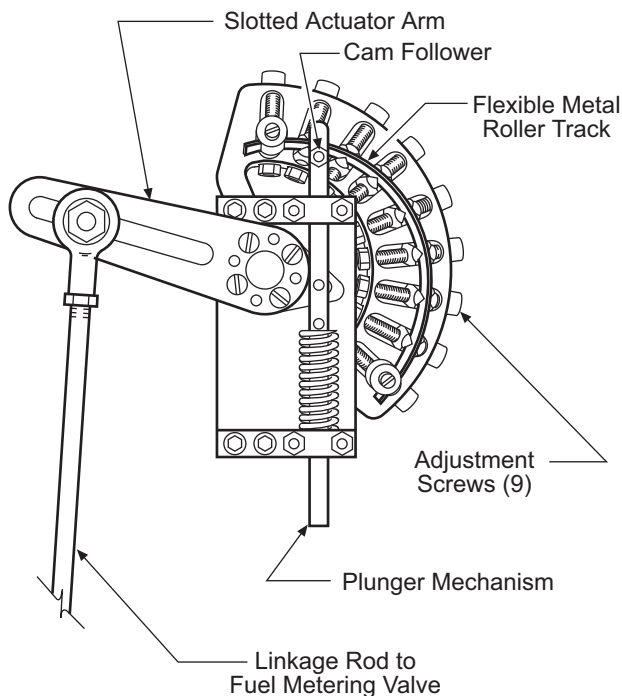
CHARACTERIZED LINKAGE (Typical)**ADJUSTMENT PROCEDURE**

Factory checkout verifies there is freedom of movement in all linkages throughout the 90° travel of the modulating motor. For gas systems, the butterfly (throttle) valve is set at the slightly open position. For oil systems, the oil metering valve is set at a predetermined position, depending on the specific valve used. Both settings are normally adequate to facilitate start-up.

Adjustment of the characterized linkage should only be done after the burner has been successfully started-up and taken from low-fire to high-fire several times. Any necessary adjustments to the fuel control linkages during start-up should be done at a ball joint connector or linkage rod coupling. The boiler, or other appliance being fired, should be warm.

Generally, combustion readings should be taken at each of the nine (9) adjustment screws in the quadrant. AS A STARTING POINT, low and high fire flue gas composition should be in the tabulated range shown below:

CAUTION

There should be no more than 3/16” variation between adjacent screws, or damage to the equipment and unreliable operation can occur.

FUEL	LOW FIRE		HIGH FIRE	
	CO ₂	O ₂	CO ₂	O ₂
Natural Gas	7½ - 9	8½ - 5	9 - 10½	5 - 2½
#2 Oil	9 - 11	8½ - 5	11 - 12½	6 - 3½
#6 Oil	9-11½	9-5½	11½ - 13½	6 - 3½

The final fuel/air ratio curve must be determined on the basis of clean combustion at all firing rates. Sufficient combustion air must be available to keep the CO generated by a gas fire below 50 PPM at all rates. Smoke levels on #2 and #6 oils respectively should not exceed a #1 and #4 spot on the Bacharach scale.

Figure 5-12 Adjustment of Characterized Linkage

ITEM 13**ADJUSTMENT OF AIR FLOW SWITCH (DIAPHRAGM)****DESCRIPTION**

The air flow switch is used to prove the flow of combustion air from the blower assembly. It causes the fuel valve to close or fail to open upon loss of or inadequate combustion air in less than 4 seconds upon loss of air.

HOW IT WORKS

The air flow switch is wired in series with the flame safeguard. When the blower starts, creating an air flow through the burner housing, the switch closes delivering electricity to the flame safeguard.

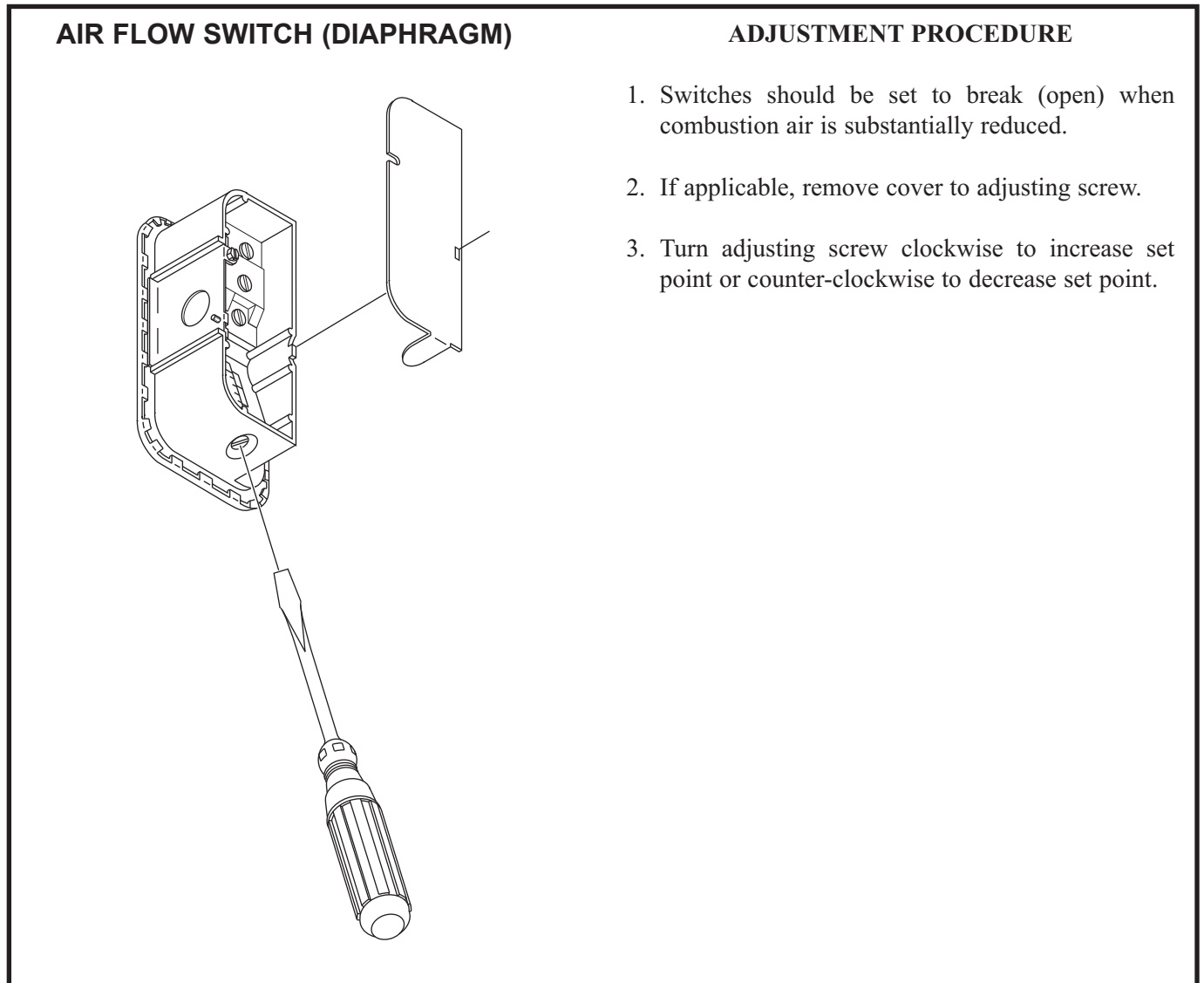

Figure 5-13 Adjustment of Air Flow Switch (Diaphragm)

PART VI

BURNER START-UP

CAUTION

This bulletin has been prepared as a guide in burner start-up operations. It is written for the start-up specialist who is thoroughly qualified both by training and experience.

Due to wide variations in engineering specifications, state and local codes, utility and insurance underwriters requirements, etc., the contents herein are of a general nature. If additional information is required or if questions arise concerning specific requirements, please contact your local representative or the factory.

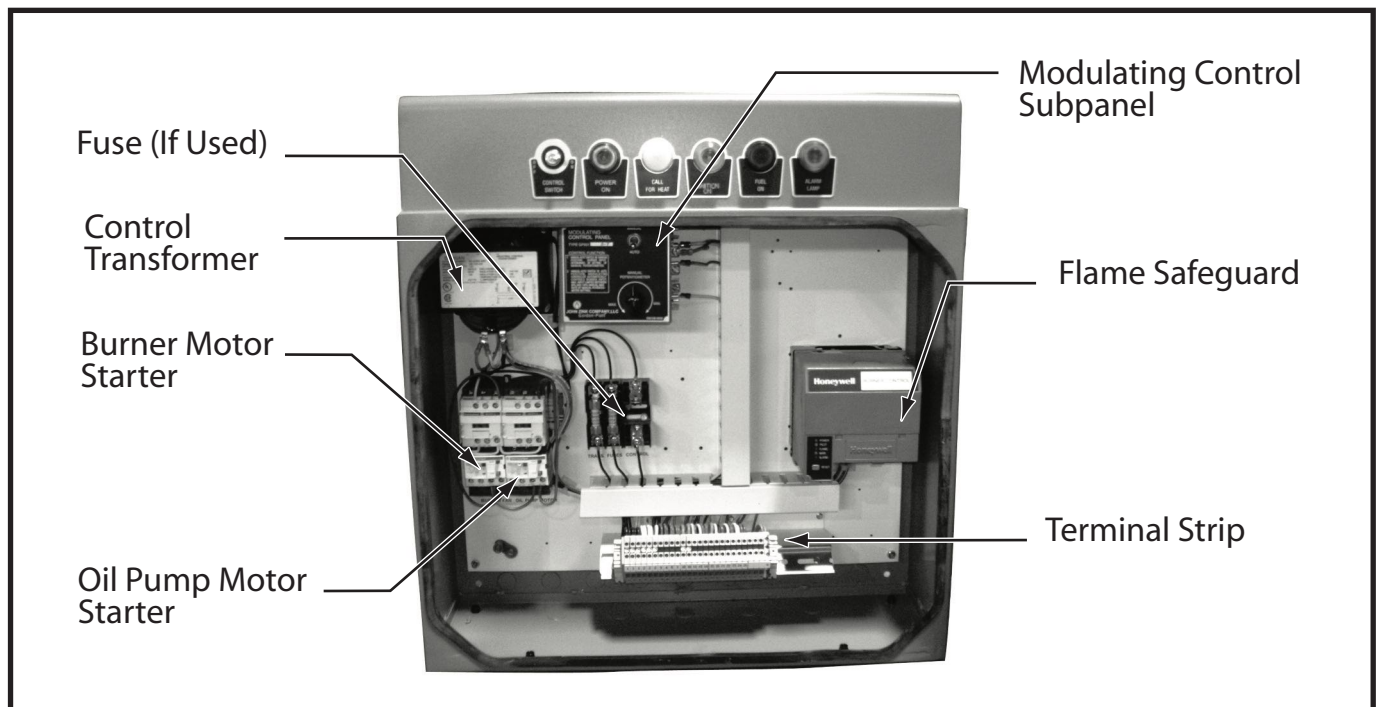

FIGURE 6-1 Typical Control Panel

1. FLAME SAFEGUARD INSTALLATION -

Assure flame safeguard is properly installed in its subbase.

2. IDENTIFICATION OF CONTROLS -

Review the burner operating sequence and wiring diagram in the instructions manual. Study these items and identify the various controls from the typical control panel assembly shown above.

NOTE

The burner flame safeguard is often times packaged and shipped in a separate carton; however, the control cabinet will contain the mounting subbase which is installed and prewired at the factory. See separate instructions on flame safeguard for mounting the unit in the subbase.

NOTE

Do not proceed with start-up unless all applicable checklist items in Part I and preliminary adjustment requirements in Part V have been satisfied.

If the burner is a combination gas-oil unit, it is recommended that the burner be fired on gas first so the correct input rate in BTU's per hour may be determined by reading the gas meter.

3. GAS BURNERS -

(See Paragraph 4 for Oil Burners)

3.1 REVIEW BURNER MATERIAL LIST IN THE INSTRUCTIONS MANUAL AND ANNOTATE THE FOLLOWING INFORMATION:

- (1) Firing Rate (MBTU)
- (2) Cubic Feet of Gas per Hour (CFH)
- (3) BTU per Cubic Foot (BTU/CF)
- (4) Required Gas Pressure at Control Inlet (inches w. c.)
- (5) Required Gas Pressure at Orifices (taken at burner manifold) (inches w. c.)

NOTE

The above information is pertinent to setting up the burner.

3.2 START-UP SETTINGS OF BURNER CONTROLS - Using the burner operating sequence, proceed up to the step where the manual pilot gas cock is to be opened.

WARNING

During initial start-up, the operator must be on constant alert for emergency conditions such as fuel leaks, electrical malfunctions, etc. The location of all manual shutoff valves and disconnect switches should be clearly in mind so the burner can be quickly shut down if necessary. Should the burner fail to ignite, never manually manipulate the flame safeguard sequence which provides for purging of the combustion chamber. Failure to observe this warning can result in an explosion causing serious injury or death.

3.3 Using the Manufacturer's Instructions Bulletin on the flame safeguard, proceed with checkout to insure proper function of the safeguard under burner operation conditions. Table 6-1 shows those checks should be performed.

The Items Below Summarize the Flame Safeguard Checkout Tests Required for Each Type of Installation	
Checkout Item	When Performed
1. Preliminary Inspection	For all Installations
2. Flame Signal Measurement	For all Installations
3. Initial Lightoff Check with Proven Pilot	If Pilot must be proven before the Main Fuel Valve can open
4. Pilot Turndown Test	If Pilot must be proven before the Main Fuel Valve can open
5. Hot Refractory Hold-in Test	For all Photocell (rectifying or infrared lead sulfide) Applications
6. Hot Refractory Override Test	For all Infrared (lead sulfide photocell) Detector Applications
7. Ignition Spark Response Test	For all Ultraviolet Detector Applications
8. Flame Signal with Hot Combustion Chamber	For all Installations
9. Safety Switch Lockout Tests	For all Installations

Table 6-1 Flame Safeguard Checkout Summary

NOTE

While performing these checks, certain adjustments and readings must be made at the appropriate time. These include, but are not limited to:

- (1) Burner Combustion Air
- (2) Gas Pressure (at control inlet and orifice)
- (3) Boiler Limit Controls
- (4) Draft Controls
- (5) Other Controls Electrically Interlocked with the Burner Control System
- (6) Gas Flow thru Utility Meter (CFH)
- (7) CO₂ and CO
- (8) Stack Temperature

3.4 LOW AND HIGH GAS PRESSURE SWITCHES - If burner is equipped with low and high gas pressure switches, perform the following steps:

- 3.4.1 Close the main manual gas shutoff valve and install a manometer in the upstream test port of the safety gas shutoff valve.
- 3.4.2 Reopen the main manual gas shutoff valve.
- 3.4.3 Cycle the burner to high fire and take gas pressure reading on manometer. Using the main manual gas shutoff valve, throttle down the gas flow to a point where the manometer reading is approximately 10% below the previous reading, then adjust the low gas pressure switch downward until it breaks and shuts down the burner. Restore main manual gas shutoff valve to full open.
- 3.4.4 To insure the switch is functionally sound and properly installed, recycle the burner to high fire and again use the main manual gas shutoff valve to throttle the gas flow. The low gas pressure switch should immediately break and shut down the burner at 10% reduced pressure.
- 3.4.5 Turn main manual gas shutoff valve to off, then remove manometer and reinstall test plug in gas safety shutoff valve. Restore main manual gas shutoff valve to full open.
- 3.4.6 Cycle the burner on-off several times to assure the switch will not cause nuisance shutdowns as the burner ignites.

HIGH GAS PRESSURE SWITCH ADJUSTMENT

- 3.4.7 Cycle the burner to high fire. Slowly adjust the switch downward until the switch breaks and shuts down the burner, then reverse the adjustment so the setting is approximately 10% greater than the reading at which the switch broke.

Example

If the switch broke and shut down the burner at 4.0" w.c., then set the switch at 4.5" w. c.

- 3.4.8 Cycle the burner on-off several times to assure the switch will not cause nuisance shutdowns as the burner ignites.

3.5 FINAL CO₂ AND CO ANALYSIS - With gas input rate established, perform a final CO₂ analysis and make air adjustments as necessary. The final air settings should produce a flue gas analysis of between 8½% and 9½% CO₂ without CO.

CAUTION

Do not set fire visually on forced draft burners. Instruments are the only safe and reliable means to determine the proper adjustments.

3.6 MOTOR RUNNING CURRENT AND VOLTAGE CHECK -

- 3.6.1 Measure motor running current after final air adjustments have been made. Current should not exceed motor service factor amps shown on motor nameplate.
- 3.6.2 Check control voltage on terminals 1 and 2 as motor starts. Voltage should not drop below 102 volts (even momentarily) or difficulty may occur in control operation. Extreme voltage drop indicates inadequate service wire size to the burner.

3.7 BURNER SAFETY CHECK -

- 3.7.1 Start and stop the burner several times to insure proper operation. Check for proper functioning of low-water cutoff, high limit and/or operating control.
- 3.7.2 Check operation of flame safeguard by simulating a flame failure, making certain the burner locks out on safety within the time limits of the control.
- 3.7.3 Using burner operating sequence, start the burner in accordance with the step by step operating sequence procedure. As the burner enters the flame safeguard sequence, verify each burner function at the timing indicated.
- 3.7.4 Prior to releasing burner into final operation, check the main SSO valves for tight shut off. Perform leak test per valve manufacturer instructions.

3.8 NORMAL OPERATION - Providing the setup and checkout operations outlined in Items 3 through 3.7 above have been properly completed and all tests have been found to be satisfactory, the burner is now ready for normal gas firing operations.

GAS FIRING NOTES _____

4. AIR ATOMIZING OIL BURNERS - (See 1-F-40.3 for Gas Burners and Pressure Atomizing Oil Burners)

4.1 REVIEW BURNER MATERIAL LIST IN THE INSTRUCTIONS MANUAL AND ANNOTATE THE FOLLOWING INFORMATION:

- (1) Oil Firing Rate (GPH)
- (2) Oil Pressure at Nozzle (PSIG)
- (3) Air Pressure at Nozzle (PSIG)

NOTE
The above information is pertinent to setting up the burner.

4.2 ADJUSTMENTS DURING START-UP - Using the burner operating sequence, proceed up to the step where the manual pilot gas cock is to be opened.

WARNING
During initial start-up, the operator must be on constant alert for emergency conditions such as fuel leaks, electrical malfunctions, etc. The location of all manual shutoff valves and disconnect switches should be clearly in mind so the burner can be quickly shut down if necessary. Should the burner fail to ignite, never manually manipulate the flame safeguard sequence which provides for purging of the combustion chamber. Failure to observe this warning can result in an explosion causing serious injury or death.

The Items Below Summarize the Flame Safeguard Checkout Tests Required for Each Type of Installation	
Checkout Item	When Performed
1. Preliminary Inspection	For all Installations
2. Flame Signal Measurement	For all Installations
3. Initial Lightoff Check with Proven Pilot	If Pilot must be proven before the Main Fuel Valve can open
4. Pilot Turndown Test	If Pilot must be proven before the Main Fuel Valve can open
5. Hot Refractory Hold-in Test	For all Photocell (rectifying or infrared lead sulfide) Applications
6. Hot Refractory Override Test	For all Infrared (lead sulfide photocell) Detector Applications
7. Ignition Spark Response Test	For all Ultraviolet Detector Applications
8. Flame Signal with Hot Combustion Chamber	For all Installations
9. Safety Switch Lockout Tests	For all Installations

Table 6-2 Flame Safeguard Checkout Summary

- 4.3** Using the Manufacturer's Instructions Bulletin on the flame safeguard, proceed with those tests which verify pilot and flame signal characteristics.
- 4.4** After pilot characteristics and flame signal have been proven satisfactory, permit the flame safeguard to cycle through to main burner ignition.

WARNING

To avoid risk of burn injuries, gloves should be worn when making adjustments to heated oil systems as the circulating lines and piping can be very hot.

- 4.5** Make low fire input, fuel-air ratio and combustion adjustments. Observe oil spray through sight glasses and determine if spray is impinging on swirler cylinder. If so, loosen backplate collar set screws and slide the drawer assembly forward until impingement ceases; then re-tighten set screws.
- 4.6** After proper boiler warm-up, run burner to high fire and make input and fuel-air ratio adjustments. Observe base of flame through back-plate sight glasses. Flame should be observed with filtered glass (welder's glass) for eye protection.
- 4.7** Oil drawer assembly adjustments for high fire.

NOTE

Changing the oil nozzle/air diffuser relationship involves different procedures depending on the oil drawer assembly used. (See Figure 5-1)

Drawer assemblies WITHOUT the quick draw oil gun feature requires removal of the complete oil drawer from the burner housing, then re-positioning the air diffuser. For those WITH the quick draw feature, the relationship can be changed by loosening the set screws that secure the oil gun within the guide tube, then sliding the gun back or forward while the drawer is installed in the burner.

Set screws or clamp screws must be re-tightened after each adjustment.

- 4.7.1** If air diffuser shows signs of carboning or if diffuser slots appear dark, move oil nozzle forward by small increments. If flame exhibits signs of instability, move nozzle to the rear a little at a time, until stability is obtained.
- 4.7.2** Manually run the burner to low fire and visually determine if there is any oil spray impingement on diffuser center hole. If so, re-check nozzle pressure, fuel-air ratio and primary air adjustments and re-adjust as required.

4.7.3 If impingement persists, move oil nozzle forward until impingement ceases.

4.7.4 After oil drawer adjustments have been made, run burner through several ignitions, low fire and high fire cycles to check for proper performance.

4.7.5 At no point should the burner be left operational if flame impingement or sooting is present during flame observations.

4.8 Removal of oil gun for extended gas firing.

WARNING

If this operation is going to be done while the burner is firing on gas, the burner must be manually run to its lowest firing rate and held there until completed. To avoid risk of burn injuries, always wear gloves if the oil system is the heated variety as the circulating lines and piping can be very hot.

4.8.1 Make sure set screws in rear collar are holding oil gun securely.

4.8.2 Disconnect atomizing air or steam, main oil and circulating loop lines (if used).

4.8.3 Using a large flat bladed screw driver, rotate the three “quarter turn” fasteners on the oil gun flange 90° CCW to disengage them.

4.8.4 Pull oil gun straight out of guide tube.

CAUTION

Do not tamper with the position of the collar after the oil gun is removed.

WARNING

Cover plate must be installed if burner is to be fired on gas with oil gun removed or an explosion can occur resulting in serious injury or death, or property damage.

4.8.5 Install cover plate on guide tube flange with the three captive “quarter turn” studs. (See Figure 5-1)

4.9 Re-installation of the oil gun. To re-install the oil gun, reverse the order of the steps outlined above. If the position of the collar has not been changed, the oil nozzle will return to its original relationship with the air diffuser when the three flange studs are re-engaged.

4.10 FINAL CO AND SMOKE ANALYSIS

CAUTION

Do not set fire visually on forced draft burners. Instruments are the only safe and reliable means to determine the proper adjustment.

4.10.1 IF COMBINATION GAS-OIL BURNER - Leave combustion air adjustments set as they were for gas firing and adjust the high fire supply oil pressure to obtain a flue gas analysis as shown in table on page 41. (See 1-F-40.3 for Gas Burners)

NOTE

Above method of setting up combination burners assures a smooth transfer between fuels without further adjustment and allows for simplified capacity calculations.

4.10.2 IF STRAIGHT OIL BURNER - LOW FIRE SETTING - Set the nozzle air pressure to about 12-15 PSIG by adjusting the air metering bleed valve. Adjust the oil metering valve to deliver an oil pressure of 13-16 PSIG. The oil metering valve position for low fire can be set at 1 to 2.5 on the indicator dial. (See Figure 5-3 for louver box adjustment)

4.10.3 HIGH FIRE SETTING - Using the manual potentiometer, bring the burner up to the high fire position.

4.10.4 Adjust the nozzle air and oil pressures to the PSIG shown on the burner material list. (See Figure 5-7 and 5-10)

NOTE

The maximum air pressure allowed is 40 to 45 PSIG for Piston type compressors.

The high fire oil nozzle pressure is set by adjusting the back pressure regulating and relief valve while the oil metering valve may be used for trim purposes.

If possible, use 90° rotation of the oil metering valve between low and high fire. (See Figure 5-5)

Adjust air inlet louver for proper CO₂ and smoke readings at full firing rate. (See Figure 5-3)

Type Oil	% CO ₂	% O ₂	Smoke No.
#2	11 - 12 1/2	3.5 - 6	0 - 2
#4 - 5 - 6	11 1/2 - 13 1/2	3.5 - 6	0 - 4

4.10.5 After obtaining the proper combustion on high fire, drive the burner back to low fire.

4.10.6 If necessary, reset low fire for proper combustion and check burner at 25%, 50% and 75% for rich or lean spots in the firing rate. The linkage arms may have to be changed to get more or less combustion air or oil on high fire.

4.11 LOW OIL PRESSURE SWITCH -

If burner is equipped with a low oil pressure switch, the switch should be set 10 to 15% below the final adjusted high fire “supply” oil pressure. Perform the following steps:

4.11.1 Annotate the “supply” oil pressure (PSIG) while the burner is at high fire.

4.11.2 Adjust the switch 10 to 15% below this pressure.

4.11.3 With the burner at low fire, slowly adjust the oil pressure regulator to obtain a reduced “supply” pressure making sure the switch cuts off the burner flame as the oil pressure drops past the PSI setting.

4.11.4 Adjust the oil pressure regulator to a higher pressure to allow the burner to be recycled to high fire, then restore the high fire “supply” oil pressure annotated above.

4.12 LOW OIL TEMPERATURE SWITCH-

If burner is equipped with a low oil temperature switch, the switch should be set 30° below the firing temperature. Perform the following steps:

4.12.1 Annotate the oil temperature while burner is firing.

4.12.2 Adjust the switch 30° below this temperature.

4.12.3 With the burner at low fire, slowly adjust the oil temperature to obtain a reduced temperature making sure the switch cuts off the burner flame as the temperature drops past the temperature setting.

4.12.4 Adjust the trim heater thermostat control to the annotated temperature above.

4.13 HIGH OIL TEMPERATURE SWITCH-

If burner is equipped with a high oil temperature switch, the switch should be set 30° above the firing temperature to a maximum of 250. Perform the following steps:

4.13.1 Annotate the oil temperature while the burner is firing.

4.13.2 Adjust the switch 30° above this temperature (maximum 250).

4.13.3 With the burner at low fire, slowly adjust the oil temperature to obtain a higher temperature making sure the switch cuts off the burner flame as the temperature rises past the temperature setting.

4.13.4 Adjust the trim heater thermostat control to the annotated temperature above.

4.14 CLEANING OF OIL SYSTEM COMPONENTS AFTER START-UP

NOTE

It is not uncommon for the oil system components to become dirty or clogged during initial start-up as foreign matter from the oil lines is pumped through the system. Cleaning may be necessary.

WARNING

Prior to cleaning:

Turn OFF the main manual fuel shutoff valves including pilot gas cock, if applicable. If a multi-fuel burner, shut OFF all fuels.

Turn OFF all electrical disconnects to the burner and any other equipment or systems electrically interlocked with the burner.

For heated oil systems, always wear gloves since the circulating lines and piping can be very hot.

4.14.1 Remove oil gun and/or oil drawer assembly, disassemble oil nozzle and clean using solvent and wooden toothpick to avoid damage to the finely machined surfaces.

4.14.2 Reassemble oil nozzle and replace oil drawer assembly.

4.14.3 Restores valves and electrical disconnects to ON.

4.15 BURNER SAFETY CHECK

4.15.1 Start and stop the burner several times to insure proper operation. Check for proper functioning of low-water cutoff, high limit and/or operating control.

CAUTION

Proper operation of low-water cutoffs must be checked by lowering the total water level in the boiler and not by blowing down the low water columns.

4.15.2 Check operation of flame safeguard by simulating a flame failure, making certain the burner locks out on safety within the time limits of the control. Use Table 6-2 for final flame safeguard check out.

4.15.3 Using burner operating sequence, start the burner in accordance with the step by step operating sequence procedure. As the burner enters the flame safeguard sequence, verify each burner function at the timing indicated.

4.16 NORMAL OPERATION-

Providing the set-up and checkout operations outlined above have been properly completed and all tests have been found to be satisfactory, the burner is now ready of normal oil firing operations.

OIL FIRING NOTES

PART VII

TROUBLE SHOOTING

The following is a list of possible problems and conditions that may exist on start-up and the corrective measures to be taken. This deals only with combustion problems. Please refer to your flame safeguard manual and/or the John Zink Company, LLC wiring diagram for any electrical problems.

1. Oil burner does not light, goes out on flame failure in main flame position:
 - a. Main oil valve not energized.
 - b. Oil metering valve not open far enough.
 - c. Compressed air too high.
 - d. Air louver open too far.
2. Oil burner lights but flame does not retain to burner head:
 - a. Drawer assembly not positioned properly. Move forward or backward.
 - b. Oil pressure at nozzle too low.
 - c. Air pressure at nozzle too low.
 - d. Oil temperature too low or too high.
 - e. Air louver too far open.
 - f. Nozzle too far forward through centerhole of diffuser.
 - g. Too much spread between oil pressure and air pressure.

NOTE

If the oil fire is not retaining to the combustion head, the burner will build carbon on the head and fireside surfaces of the boiler. This can best be seen through the rear peep sight on the burner. Look for rivulets of oil running down the vanes of the air diffuser and/or a wetting of oil on the inner fire cylinder of the swirler. Looking at the flame from the rear of the burner, the color of the flame should be the same all across the head. A darker color at the center usually means it is blowing off the head.

Look at the flame from the rear of the boiler. If it is retaining to the head, it will have a definite shape. If it is blowing off the head, the center of the fire will appear dark and it will be scattered over the boiler with no apparent shape or pattern. There will also be pulsation of the burner flame.

3. Burner flame retains to head on lo-fire but blows off while modulating to hi-fire and/or blows out resulting in a flame failure: (Also see Items 2a - 2g above)
 - a. Louver box may be opening too fast, causing a lean spot at about 25% or 50% of range. If so, reduce the travel of the air louver by moving the ball swivel in on the jack shaft.
 - (1) To slow down the louver opening in the first 1.0" of travel: Normally, the linkage are on the jack shaft and the louver box are positioned approximately 45° down from the center. Loosen the two set screws in the linkage arm at the louver box operated from the common jack shaft; swing the arm up until it is about 10° off center (or almost straight out from the burner) then tighten set screws and linkage rod. The louver will open much slower in the first 1.0" of travel, but open the same for hi-fire.
 - (2) To speed up the louver travel in the first 1.0" of travel: Do the same as above except in this case, increase the angle or move the arm down on the shaft at the louver box until it is 70° or so down from the center. This will cause the louver to "pop" open at the start but still open to the same amount for hi-fire.

NOTE

The only sure way to check for the above mentioned lean spot is with proper CO₂ test equipment. CO₂ reading should increase from approximately 10% CO₂ on lo-fire to 12 - 13% CO₂ on hi-fire without any dips down to 7 - 8% CO₂.

- (3) If it is determined the air louver is set properly, the same linkage arm adjustments can be made on the oil metering valve to open it faster or slower, just off of lo-fire.
- b. Check oil strainers for possible blockage. On lo-fire, there may not be enough oil flow. As unit modulates to hi-fire, the burner is starved for oil.

NOTE

On new burner start-up, it is not uncommon to plug up the strainers with weld slag, dirt, etc. These should be checked after start-up is complete.

- c. Check nozzle. It may also have a partial blockage.
 - d. Compressed air at nozzle is not high enough.
4. Burner rumbles when modulating to hi-fire:
- a. Burner is too lean. Check CO₂. Reset air or oil linkage.
 - b. Air louver is opening too fast. Reset air linkage arms as discussed above.
 - c. Drawer assembly not set properly.
 - d. Oil may be too hot, causing gas to form.
 - e. Flame is blowing off head.
 - f. For burners with air metering valves, this valve may not be open far enough.
5. Smoky flame:
- a. Check CO₂. Flame may be too “rich” caused by not enough combustion air. Open louver box.
 - b. Check for proper combustion air opening into boiler room. The outside air opening must be equal to the area of the boilers breeching but not less than eight square inches of free area per gallon of oil input.
 - c. Not enough atomizing air. Screw down regulator on air bleed off line or close air metering valve more, if applicable.
 - d. Oil too cold.
 - e. Dirty nozzle, causing poor atomization of the oil.
 - f. Burner combustion air inlet blower dirty.

NOTE

In some rare cases, it is possible to get the burner so lean or have so much excess air that the burner will produce white smoke or light grey colored smoke. This white smoke can also be caused by raw oil impinging on hot boiler surfaces. At no point should the burner be left operational if flame impingement or sooting is present during flame observation.

CAUTION

Observe flame with filtered glass (welder’s glass) for eye protection.

- 7. Carbon buildup on the firesides of the boiler:
 - a. Dirty nozzle.
 - b. Oil flame not retaining to head.
 - c. Oil too cold, causing poor atomization.
 - d. Spray angle of the nozzle too wide; consult factory.
 - e. Oil spray impinging on burner head, causing raw oil to deposit on boiler.
- 8. Flame length too long:
 - a. Drawer assembly too far back; move forward slowly.
 - b. Compressed air to nozzle too low. The higher the air pressure is, the more intense the flame will be.
 - c. In the case of a very short firebox, a nozzle with wider spray angle may be needed; consult factory.

START-UP NOTES: _____

6. Sparklers in the oil flame:
- a. Oil is too cold, causing poor atomization.
 - b. Oil impingement on the combustion head caused by:
 - (1) Drawer assembly too far to rear, impinging oil on inner fire cylinder of swirler.
 - (2) Nozzle is not protruding through centerhole of air diffuser, causing impingement of oil on the diffuser.
 - (3) Dirty nozzle.
 - (4) Oil flame not retaining to the head.
 - c. Dirt and grit in the oil. This is more pronounced in the heavier oils.
 - d. Water in the oil.

PERIODIC TESTING RECOMMENDED CHECK LIST

ITEM	FREQUENCY	ACCOMPLISHED	REMARKS
Gauges, monitors and indicators	Daily	Operator	Make visual inspection and record readings in log
Instrument and equipment settings	Daily	Operator	Make visual check against recommended specifications
Firing rate control	Weekly Semiannually Annually	Operator Service technician Service technician	Verify factory settings Verify factory settings Check with combustion test
Flue, vent, stack or outlet dampers	Monthly	Operator	Make visual inspection of linkage, check for proper operation
Igniter	Weekly	Operator	Make visual inspection, check flame signal strength if meterfitted (see "Combustion safety controls")
Fuel Valves			
Pilot and main	Weekly	Operator	Open limit switch--make aural and visual check--check valve position indicators and check fuel meters if so fitted
Pilot and main gas or main oil	Annually	Service technician	Perform leakage tests--refer to instructions
Combustion safety controls			
Flame failure main	Weekly	Operator	Close manual fuel supply for (1) pilot, (2) fuel cock, and/or valve(s); check safety shutdown timing; log
Flame signal strength	Weekly	Operator	If flame signal meter installed, read and log; for both pilot and main flames, notify service organization if readings are very high, very low, or fluctuating; refer to instructions
Pilot turndown tests	As required/annually	Service technician	Required after any adjustments to flame scanner mount or pilot burner verify annually--refer to instructions
Refractory hold in	As required/annually	Service technician	See "Pilot turndown tests"

PERIODIC TESTING RECOMMENDED CHECK LIST

ITEM	FREQUENCY	ACCOMPLISHED	REMARKS
Low-water fuel cutoff and alarm	Daily/Weekly Semiannually	Operator Operator	Refer to instructions Perform a slow drain test in accordance with ASME Boiler and Pressure Vessel Code Section VI
High limit safety control	Annually	Service technician	Refer to instructions
Operating control	Annually	Service technician	Refer to instructions
Low draft, fan, air pressure, and damper position interlocks	Monthly	Operator	Refer to instructions
Atomizing air/steam interlock	Annually	Service technician	Refer to instructions
High and low gas pressure interlocks	Monthly	Operator	Refer to instructions
High and low oil pressure interlocks	Monthly	Operator	Refer to instructions
High and low oil temperature interlocks	Monthly	Operator	Refer to instructions
Fuel valve interlock switch	Annually	Operator	Refer to instructions
Purge switch	Annually	Service technician	Refer to instructions
Burner position interlock	Annually	Service technician	Refer to instructions
Rotary cup interlock	Annually	Service technician	Refer to instructions
Low fire start interlock	Annually	Service technician	Refer to instructions
Automatic changeover control (dual fuel)	At least annually	Service technician	Under supervision of gas utility
Safety valves	As required	Operator	In accordance with procedure in Section VI, ASME Boiler and Pressure Vessel Code, Recommended Rules for Care and Operation of Heating Boilers
Inspect burner components	Semiannually	Service technician	Refer to instructions

NOTES:

NOTES:

PART VIII

SUPPLEMENTARY DATA

This manual should be kept with other literature on your boiler room equipment as a complete reference source for maintenance and service.



PART IX

HOW TO ORDER PARTS

Notice

Always Include U. L. SERIAL NUMBER When Ordering Parts !

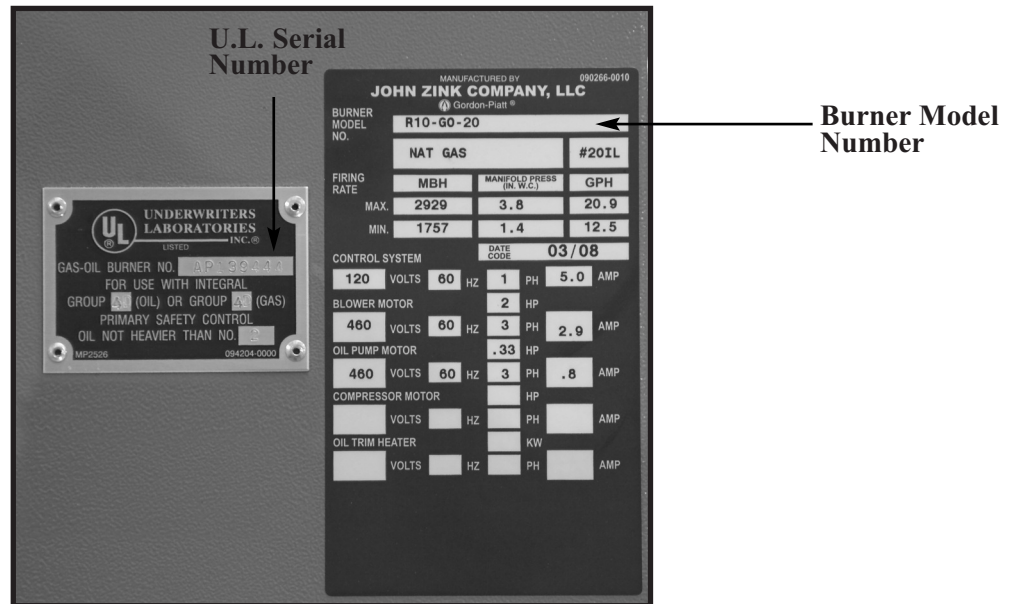

For replacement parts contact OEM Boiler Parts

www.gordonpiatt.com

717-367-9900